

TRIPOLIET



INSTRUCTION MANUAL

MODEL 630-PL TYPE 2

VOLT-OHM-MILLIAMMETER

MANUAL ONLY \$.50

-If You Didn't Get This From My Site,
Then It Was Stolen From...

www.SteamPoweredRadio.Com



MODEL 630-PL
Volt-Ohm-Milliammeter

The Triplet Electrical Instrument Company
 Bluffton, Ohio

FOREWORD

With your purchase of a Model 630-PL Volt-Ohm-Milliammeter, you have made a worthwhile investment, not only in a fine instrument, but backed up by a company which has been making instruments for more than half a century. The Triplett Company stands behind your 630-PL and will give all possible assistance in its use and maintenance.

TRIPLETT WARRANTY AND CONDITIONS OF SALE

The Triplett Electrical Instrument Company warrants instruments manufactured by it to be free from defective material or factory workmanship and agrees to repair or replace such instruments which under normal use and service, disclose the defect to be the fault of our manufacturing. Our obligation under this warranty is limited to repairing or replacing any instrument or test equipment which proves to be defective, when returned to us transportation prepaid, within ninety (90) days from the date of original purchase.

This warranty does not apply to any of our products which have been repaired or altered by unauthorized persons or service stations in any way so as, in our judgment, to injure their stability or reliability or which have been subject to misuse, negligence or accident or which have had the serial number altered, effaced, or removed. Neither does this warranty apply to any of our products which have been connected, installed, or adjusted otherwise than in accordance with the instructions furnished by us. Accessories including all vacuum tubes and batteries not of our manufacture used with this product are not covered by this warranty.

The Triplett Electrical Instrument Company reserves the right to discontinue models at any time, or change specifications or design, without notice and without incurring any obligation.

Upon acceptance of the material covered by this invoice the purchaser agrees to assume all liability for any damages and bodily injury which may result from the use or misuse of the material by the purchaser, his employees, or others, and that The Triplett Electrical Instrument Company shall incur no liability for direct or consequential damage of any kind.

Parts will be made available for a maximum period of five (5) years after the manufacture of this equipment has been discontinued. Parts include all materials, charts, instructions, diagrams, accessories, et cetera, which were furnished in the standard or special models.

This warranty and conditions of sale are in lieu of all others expressed or implied and no representative or person is authorized to assume for us any other liability in connection with the sale of our products.

1-419-358-5015

The Triplett Electrical Instrument Company
Bluffton, Ohio

Printed in U. S. A. 286 HARMON RD Part No. 84-154

(For above serial No. 29,500 and after April 30, 1963)

	Page
Familiarization	4
Operation	
Measuring DC Volts	6
Measuring AC Volts	8
Measuring DC Resistance	10
Measuring DC Current	12
Measuring Output Volts (DB)	14
Operation Chart	16
Measuring Capacity	18
Additional Measurements	
Measuring Kilovolts	20
Measuring High DC Current	21
Accessories	21
Additional Applications	22
Maintenance	25
Interior View — Parts Location	26
Replaceable Parts	27
Circuit Diagram	28
Data	
DB Chart	29
EIA Condenser Color Code	30
EIA Resistor and Speaker Color Code	31
EIA Wiring Color Code	31
EIA Transformer Color Code	32

The Model 630-PL Volt-Ohm-Milliammeter is a rugged long scale multi-range instrument in a compact portable case.

Remove the test leads from the small envelope and notice the two alligator clips enclosed. The clips slide over the ends of the test prods and make very handy connectors.

Plug the small ends of the test leads into the panel jacks marked COM and V- Ω -A. The jacks and plugs are especially made for trouble-free, low resistance connections.

Scales

Notice there are five scales on the meter. The top scale (red) is used when measuring ohms. This scale is marked from 0 to 1K (at left side). With the switch knob turned to $\Omega \times 1$, the ohms scale is read just as it is marked. With the switch knob turned to $\Omega \times 10$, the numbers on ohms scale must all be multiplied by 10. Likewise $\Omega \times 1K$ and $\Omega \times 100K$ mean to multiply by 1000 and 100,000 respectively.

The second scale from the top (black) is used to read all DC currents and voltages. The third from the top (red) is used for all AC voltages except the 3 volt range—the latter is read on the bottom red scale (marked 3 at full scale).

The lowest scale (black) is used for all decibel measurements. Notice the chart near the lower right hand corner of the dial. This is used in conjunction with the DB scale as explained on page 14.

Panel

Just below the meter is a small plastic screw. This is rotated with a small coin or screw driver to adjust the meter pointer to zero. This need be adjusted only occasionally but for best accuracy the pointer should always be on zero before making a measurement.

The large knob in the lower center of the panel is used to select all ranges. The markings are self explanatory.

Left of the knob is a recessed Ω ADJ control used when making resistance measurements.

To the right of the knob is a recessed switch used for reversing polarity on DC ranges.

Observe the jacks and note carefully the marking for

each. You will use the COM and V- Ω -A, jacks for most measurements. The polarity reversing switch must be in the "DC+, Ω , ACV" position for all ohm and ACV measurements.

PROTECTION: A one ampere fuse is incorporated in the ohm circuits for protecting the ohm circuit when it is accidentally placed across high voltage. A spare fuse is attached to unit inside the tester.

Accuracy

Your 630-PL is accurate to within 2% of full scale reading on all DC ranges except the 5000 volt range which is within 4%, 3% on all AC ranges except 5000 volts which is 5%, and 2% of the scale length on all resistance ranges. Precision, non-aging resistors insure lasting accuracy. All units are calibrated at 77° F. AC ranges are calibrated on a 60 cycle sine wave. In choosing ranges always endeavor to have the readings fall in the upper (or right hand) half of the scale for greatest accuracy.

Ranges

The following ranges are self contained in your 630-PL:	
DC Volts	2.5-10-50-250-1000-5000 at 20,000 Ohms per Volt/0-.250 at 10,000 Ohms per volt
AC Volts	0-3-10-50-250-1000-5000 at 5,000 Ohms per Volt
DC Microamperes	0-100 at 250 Mv.
DC Milliamperes	0-10-100-1000 at 250 Mv.
DC Amperes	0-10 at 250 Mv.
Ohms	0-1000-10,000....(4.4-44 at center scale)
Megohms	0-1-100....(4400-440,000 at center scale)
Output Volts(AC)	0-3-10-50-250-1000 at 5,000 Ohms per Volt
Decibels	-20 to +11, 21, 35, 49, 61, 75 on 600 Ohm line

Your 630-PL is well constructed but like any instrument should be handled carefully. You will also want to keep the panel clean as cleanliness and carefulness go hand in hand.

Measuring DC Volts (Fig. 1)

Rotate the selector switch to the appropriate range for DC volts. Always start with the highest range if in doubt as to the approximate voltage.

In choosing ranges, endeavor to have the readings fall in the upper, or right hand, half of the scale for greatest accuracy.

Plug the black test lead into the COM jack and the red lead into the V- Ω -A jack as shown in Figure 1.

CAUTION: When measuring up to 5000 volts set the selector switch on the 5000/1000 range, plug the red lead into the jack marked 5000 DCV, and leave the black lead in COM.

Connect the test prods ACROSS the voltage source. The red lead is positive. Where polarity is difficult to determine, the meter may read backwards. No damage will be done if this occurs. Simply reverse the polarity switch.

The V- Ω -A jack will be positive when the polarity switch is in the "DC+" position.

Read all DC voltages on the top black meter scale. Notice that the scales are not all marked exactly the same as the range indicated by the knob position. Thus 0-2.5 volts is read on the 0-250 scale (i. e. \div by 100) on all readings, the 0-1000 range is read on the 0-10 scale by adding two zeros, and the 0-5000 range is read on the 0-50 scale by adding two zeros.

The high sensitivity of 20,000 ohms per volt will allow you to take measurements in low current circuits such as grid and discriminator circuits.

Voltages as low as .005 volts, (.250 volts full scale at 10,000 ohms per volt) may be read by using 100 μ A DC current range. Simply place the range selector in the 100 μ A position and read the voltage on the 0-250 scale (divide by 1000 for volts).

CAUTION: For maximum safety do not handle tester or leads when connected to high voltages. Make certain that no condensers are charged to a high voltage.

NOTE: To measure above 1000 volts, the red lead must be plugged into the 5000 DCV jack and selector switch set on the 5000/1000 DCV range.

For handy operation chart see pages 16 and 17.

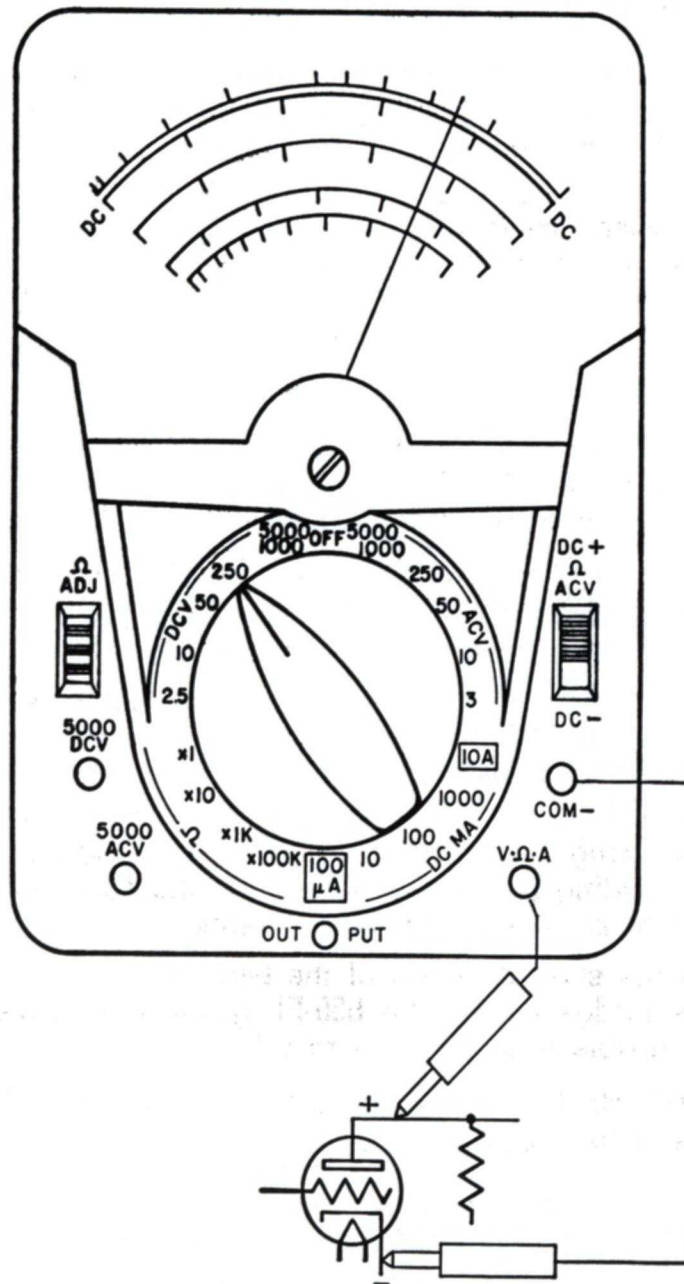

Figure 1—Measuring DC Volts

Measuring AC Volts (Fig. 2)

Rotate the Selector switch to the appropriate range for AC volts and set the polarity switch to ACV. Always start with the highest range if in doubt as to the approximate voltage.

In choosing ranges, endeavor to have the readings fall in the upper, or right hand, half of the scale for greatest accuracy.

Plug the black test lead into the COM jack and the red lead into the V- Ω -A jack as shown in Figure 2.

CAUTION: When measuring up to 5000 volts set the selector switch on the 5000/1000 range, plug the red lead into the jack marked 5000 ACV, and leave the black lead in COM.

Connect the test prods ACROSS the voltage source. As there is no polarity on AC, the red and black leads may be interchanged without causing the meter to read backwards.

Use the two lower red scales for AC volt readings. Note that the bottom scale is to be used ONLY for one range, namely the 0-3.

When using the 0-1000 AC volt range, read on the 0-10 scale by adding two zeros. When on the 5000 volt range use the 0-50 scale by adding two zeros.

With the special design of the two diodes in a modified full wave bridge circuit, the 630-PL gives a wide frequency response usable from 10 c p s to 500 Kc.

CAUTION: For maximum safety do not handle tester or leads when connected to high voltages.

NOTE: To measure above 1000 volts, red lead must be plugged into the 5000 ACV jack and the selector switch set on the 5000/1000 ACV range.

For handy operation chart see pages 16 and 17.

If You Didn't Get This From My Site,
Then It Was Stolen From...

www.SteamPoweredRadio.Com

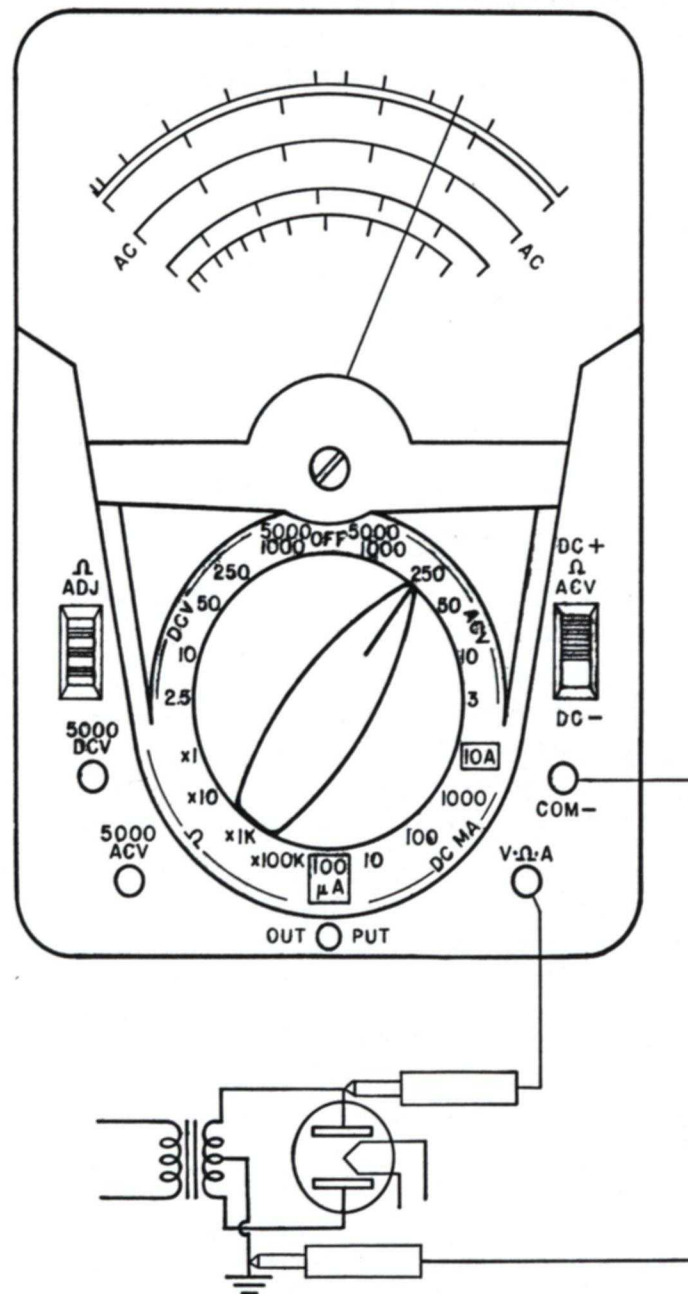

Figure 2—Measuring AC Volts

Measuring DC Resistance (Fig. 3)

Rotate the selector switch to the appropriate range for ohms determined from the following chart:

To Read	Set Switch to
0-1000 ohms	$\Omega \times 1$
0-10,000	$\Omega \times 10$
0-1 Meg.	$\Omega \times 1K$
0-100 Meg.	$\Omega \times 100K$

Set the polarity switch to Ω .

Plug the black test lead into the COM jack and the red lead into the V- Ω -A jack as shown in Figure 3.

Short the test prods together and adjust the Ω ADJ knob until the meter pointer reads 0 on the top red (Ω) scale. (The 0 for the ohms scale is at the extreme right side of the scale.)

Connect the test prods across the resistor as shown. If the resistor is wired in a circuit, disconnect one end of the resistor before taking the reading.

Each time an ohm range is changed, it is well to check the 0 setting as outlined in paragraph 4 above.

The basic scale 0-1K (0-1000) is used for reading on all ohm ranges. Simply multiply the scale numbers by 1, 10, 1000, or 100,000 as indicated by the selector switch setting.

It should be kept in mind that in the measurement of resistance a current is passed through the unknown resistor. Generally this current is so small as to be negligible. However on the 0-1000 range fairly high current is employed.

CAUTION: On X1 ohm position reading approximately center scale (4.4 ohms) the current drain from the 1.5 volt battery is 170 MA. It is desirable to make a practice of using one of the higher ohm ranges for general continuity or circuit testing. This will give you much longer battery life.

NOTE: In the ohms circuit the battery polarity at the leads is as indicated. The red lead is positive.

Since the scale of an ohmmeter is non-linear, the accuracy of the reading cannot be expressed as a per cent of full scale. Ohmmeter accuracy is generally referred to a linear scale such as the DC volt scale. Thus $\pm 3\%$ ohmmeter accuracy means an allowable ± 1.5 divisions on the DC scale. For example 2 ohms could read from about 1.75 to 2.3 ohms and be within tolerance.

NOTE: Do not touch any metal parts of the circuit when using the high ohm ranges. It is not dangerous but your body resistance can cause serious error.

For handy operation chart see pages 16 and 17.

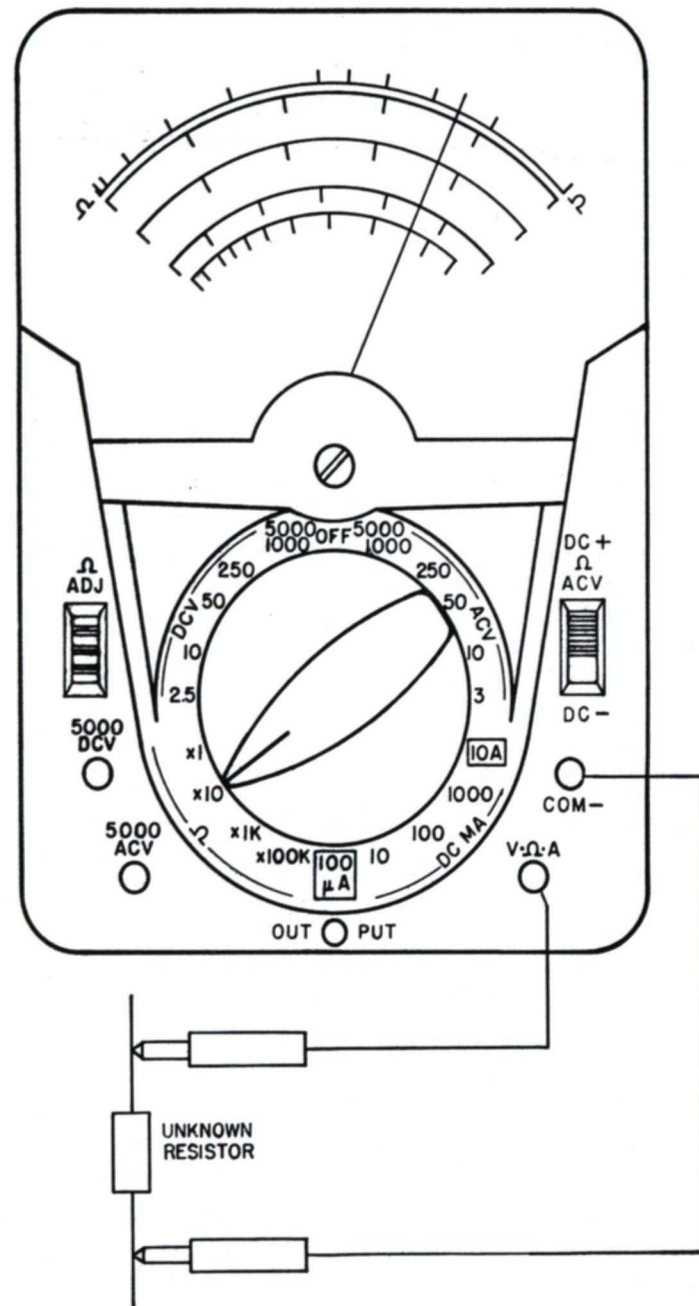

Figure 3—Measuring DC Resistance

Measuring DC Current (Fig. 4)

Rotate the selector switch to the appropriate range for DC current. Always start with the highest range if in doubt as to the approximate current.

In choosing ranges, endeavor to have the readings fall in the upper, or right hand, half of the scale for greatest accuracy.

Plug the black test lead into the COM jack and the red lead into the V- Ω -A jack as shown in Figure 4.

Connect the test prods in SERIES with the circuit to be measured. Do not test directly across any potential circuits as this may burn out the instrument and shunt. The red lead is positive. Where polarity is difficult to determine, the meter may read backwards. No damage will be done if this occurs. Simply reverse the polarity switch.

Read all current ranges (including microamperes, milliamperes, and amperes) on the upper black scale. When on the 10 Ma. range use the 0-10 scale and read direct. On the 100 Ma. range again use the 0-10 scale by adding one zero.

CAUTION: Turn off the power before connecting the meter to the circuit. Do not handle tester or leads in high voltage circuits.

In using the 100 microampere range, the meter may read differently than calculations would indicate. This is sometimes caused in low current circuits by a slight leakage of voltage due to moisture. Other times a slight potential is generated by soldering or joining of dissimilar metals. Even the proximity of fumes or liquid acids and alkalis may react with the metal parts of the circuit and generate slight currents. The fingers should not be permitted to touch the metal parts of the prods or circuit as body resistance can also upset some circuits.

For handy operation chart see pages 16 and 17.

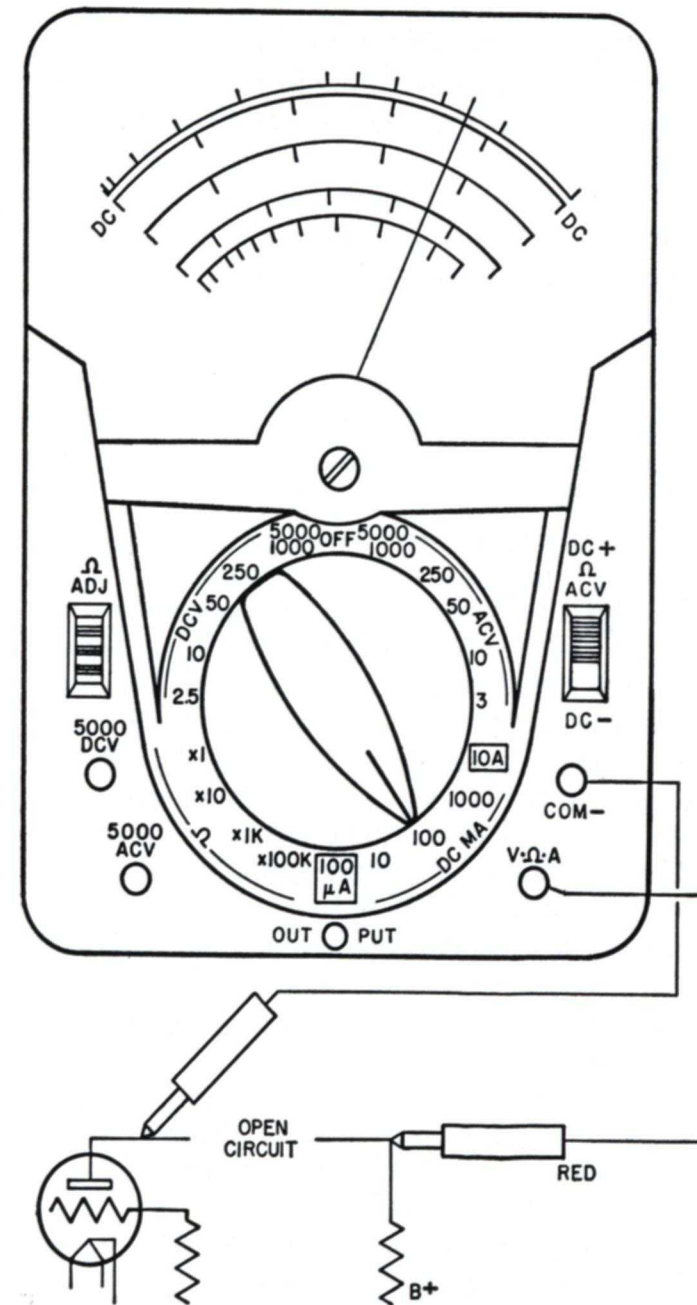

Figure 4—Measuring DC Current

Measuring Output Volts (DB) (Fig. 5)

Output is generally measured in units called the decibel, a terminology used to indicate power levels in amplifiers or telephone work.

Do not confuse the DB with the VU (Volume Unit). The VU is based on .001 watt dissipated in a 600 ohm line and is measured with a meter having special ballistic characteristics.

Rotate the selector switch to the appropriate AC volt range and set the polarity switch to ACV. Refer to the small chart on the meter dial for the range to use. Always start with the highest range if in doubt as to the approximate number of decibels.

Normally it is recommended to measure output by plugging the black lead into the COM jack and the red lead into the OUTPUT jack as shown in Figure 5.

Oftentimes a DC voltage is present in the circuit where output is to be measured. The extra jack marked OUTPUT with a .1 mfd condenser in series is provided to block the DC.

The condenser impedance is generally disregarded in most measurements. Where no DC is present, this output voltage can be read accurately by using the 630-PL as a regular AC voltmeter (i. e. by plugging the red lead into the V-Ω-A jack instead of OUTPUT.)

Connect the test prods across the plate circuit or speaker voice coil.

Read all DB ranges on the bottom black scale using the small chart on the meter dial. For example, when the selector switch is set on the 3 AC volt range, the DB scale is direct reading. When on the 10 AC volt range, add 10 to reading on the DB scale, thus with the meter reading -2, the approximate DB reading is +8 DB.

For a reference level of .006 watt in 500 ohms, subtract (+)7 DB from the reading to obtain the absolute value of decibels.

For handy operation chart see pages 16 and 17.

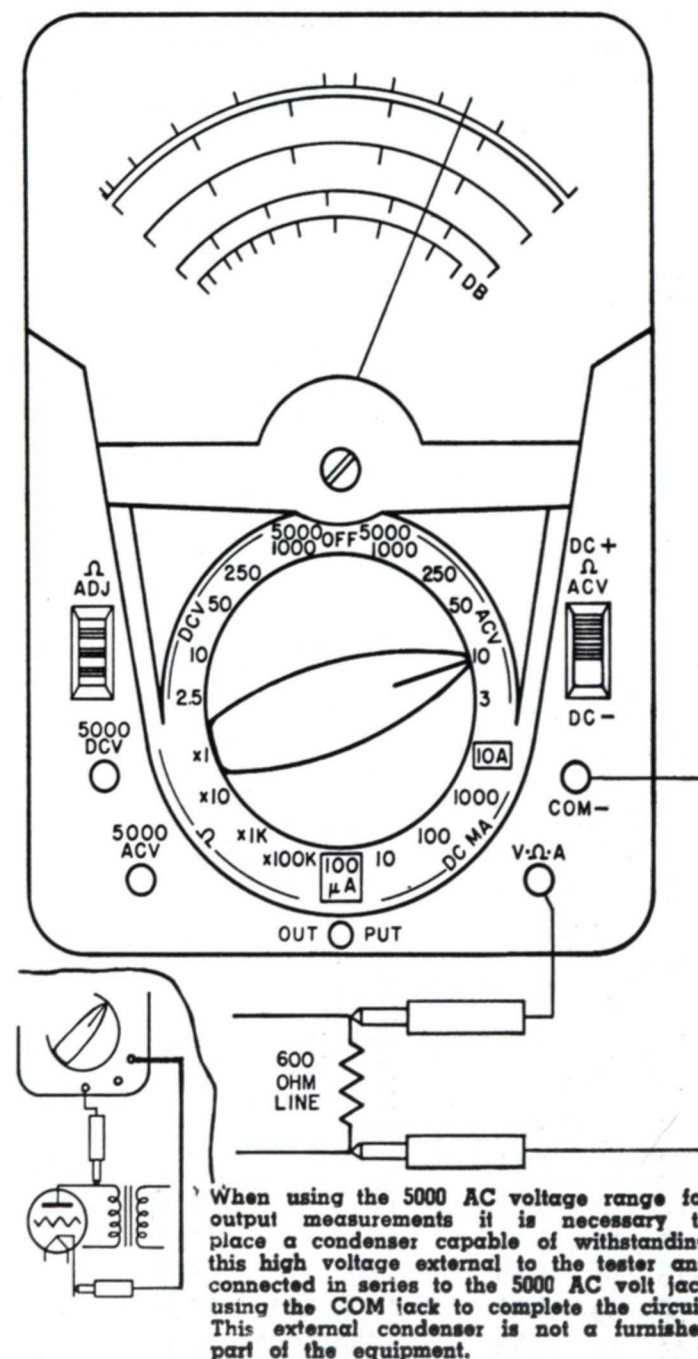

Figure 5—Measuring Output Volts (DB)

OPERATION CHART

To Measure	Set Switch To		Polarity	Plug Red* Test Lead In Jack Marked	Read On	Each Scale Div. Equals
	Selector					
DC VOLTS						
0-.250	100	μ A	either	V- Ω -A	BLACK SCALE 0-250 DC \div 1000	0.005 Volt
0-2.5	2.5	DCV	either	V- Ω -A	0-250 DC \div 100	0.05 Volt
0-10	10	DCV	either	V- Ω -A	0-10 DC \times 1	0.2 Volt
0-50	50	DCV	either	V- Ω -A	0-50 DC \times 1	1.0 Volt
0-250	250	DCV	either	V- Ω -A	0-250 DC \times 1	5.0 Volts
0-1000	1000/5000	DCV	either	V- Ω -A	0-10 DC \times 100	20.0 Volts
0-5000	1000/5000	DCV	either	5000 DCV	0-50 DC \times 100	100.0 Volts
AC VOLTS						
0-3	3	ACV	ACV	V- Ω -A	RED SCALE 0-3V AC \times 1	0.05 Volt
0-10	10	ACV	ACV	V- Ω -A	0-10 AC \times 1	0.2 Volt
0-50	50	ACV	ACV	V- Ω -A	0-50 AC \times 1	1.0 Volt
0-250	250	ACV	ACV	V- Ω -A	0-250 AC \times 1	5.0 Volts
0-1000	1000/5000	ACV	ACV	V- Ω -A	0-10 AC \times 100	20.0 Volts
0-5000	1000/5000	ACV	ACV	5000 ACV	0-50 AC \times 100	100.00 Volts
DC CURRENT						
0-100 μ a DC	100	μ a	either	V- Ω -A	BLACK SCALE 0-10 DC \times 10	2.0 μ a
0-10 Ma DC	10	DCMA	either	V- Ω -A	0-10 DC \times 1	0.2 Ma
0-100 Ma DC	100	DCMA	either	V- Ω -A	0-10 DC \times 10	2.0 Ma
0-1000 Ma DC	1000	DCMA	either	V- Ω -A	0-10 DC \times 100	20.0 Ma
0-10 AMPS DC	10	AMP	either	V- Ω -A	0-10 DC \times 1	0.2 Amp
OHMS						
0-1000	Ω \times 1		Ω	V- Ω -A	Each Scale Division Equals (in ohms)	
0-10,000	Ω \times 10		Ω	V- Ω -A	RED SCALE	0-4 4-5 5-10 10-20 20-50 50-200
0-1 Meg	Ω \times 1K		Ω	V- Ω -A	Ω \times 1	.1 .2 .5 1 5 50
0-100 Meg	Ω \times 100K		Ω	V- Ω -A	Ω \times 10	1 2 5 10 50 500
					Ω \times 1K	100 200 500 1K 5K 50K
					Ω \times 100K	10K 20K 50K 100K 500K 5 Mea
DECIBELS						
-20 to +11	3	ACV	ACV	Output	BLACK SCALE DB plus 0	* Black test lead plugged in "COM" jack for all measurements
-10 to +21	10	ACV	ACV	Output	DB plus 10	
+ 4 to +35	50	ACV	ACV	Output	DB plus 24	
+18 to +49	250	ACV	ACV	Output	DB plus 38	
+30 to +61	1000/5000	ACV	ACV	Output	DB plus 50	
+44 to +75	1000/5000	ACV	ACV	5000 ACV	DB plus 64	

Measuring Capacity (Fig. 6)

Your 630-PL can be used to measure capacity by the arrangement shown in Figure 6. It is set up as an AC volt-meter. See page 8.

Use the following chart to determine the AC voltage range to use. ALWAYS start with the selector switch on the 250 volt range since, if the condenser is shorted, serious damage may result to the meter when on a low range.

To Measure MFD	Set Selector Switch to	Deflection in AC Volts
.002	3 ACV	.45
.004		.83
.006		1.25
.008		1.65
.010		2.10

CAUTION: Do not attempt to use this test on electrolytic condensers.

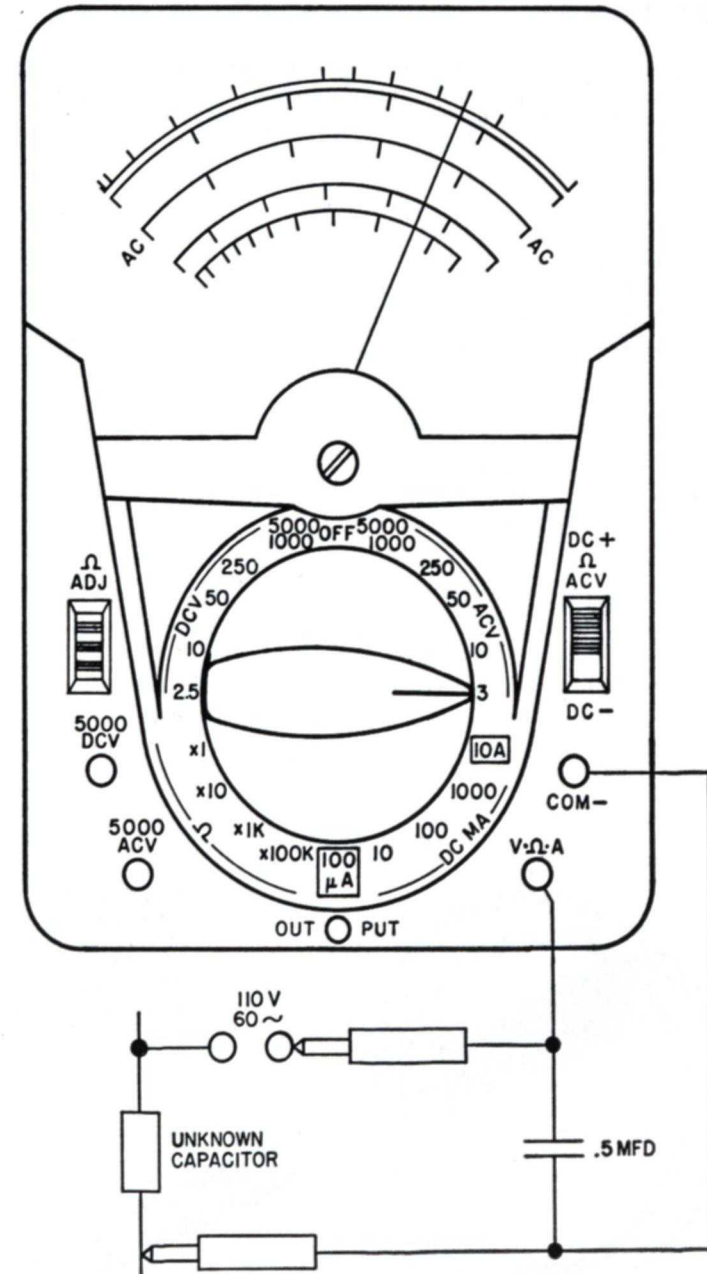

Figure 6—Measuring Capacity

Measuring Kilovolts

For measuring the high voltage employed in television receivers and in other applications, an external probe is available. See Figure 7. Probes for DC are made in three ranges 0-10,000, 0-25,000, and 0-50,000 volts. Probes for AC are also available in the lower ranges.

To use the Kilovolt probe set range selector switch on 2.5 volt DC position if the DC probe is to be used. When the AC probe is used set range selector switch on 3 Volt AC position and set the polarity switch to ACV. Plug the Kilovolt probe lead into the V-Ω-A jack on bottom right corner of the front panel. Use the black standard lead for negative or common lead with it connected in the COM jack located on the lower right side of front panel.

Kilovolt Probe	Set Selector Switch	Read on Range	Multiply by
0-10KV DC	2.5V DC	0-10V DC	1000
0-25KV DC	2.5V DC	0-250V DC	100
0-50KV DC	2.5V DC	0-50V DC	1000
0-10KV AC	3V AC	0-10V AC	1000
0-25KV AC	3V AC	0-250V AC	100

Figure 7



USE EXTREME CAUTION
in measuring the high voltages such as found in television receivers. Clip the common lead to the circuit so you will have only one probe in your hand.

Measuring High DC Current

External plug-in shunts are available to extend the DC current ranges of your 630-PL from the self-contained 0-10 to 0-25 amps. External portable shunts up to 100 amperes are also available. (See paragraph on accessories.)

Set the 630-PL selector switch to the 10 Ma. position and plug the desired external shunt into the COM and V-Ω-A jacks. Connect the line to be measured to the binding posts on top of the shunts. The external portable shunts are too large to plug into the panel and must be connected to the panel jacks by the leads furnished with the shunts.

Accessories

The following accessories for your 630-PL are available from your distributor.

Item	Part No.
DC Hi-Voltage probe 0-10 Kv	T-79-83
AC Hi-Voltage probe 0-10 Kv	79-165
DC Hi-Voltage probe 0-25 Kv	T-79-130
AC Hi-Voltage probe 0-25-Kv	79-166
DC Hi-Voltage probe 0-50 Kv	T-79-92
Carrying cases	639, 639-N and 639-F
Plug-in external shunt 0-25 DC Amp.	T-91-243
Portable external shunt 0-50 DC Amp.	T-91-244
Portable external shunt 0-100 DC Amp.	T-91-191
Clamp-on Ammeter Adapter, Model 10 (Ranges 6 to 300 AC Amps)	60A-211
Lead Assembly, No. 611 (Used in conjunction with Model 10)	79A-160
Line Separator, Model 101 (Used in conjunction with Model 10)	60A-218

In The Home

When your refrigerator motor fails to "kick out" the starting winding, use the 630-PL, to measure the AC line voltage. If the voltage is below about 100 volts, notify your power company.

If your electric stove does not seem to heat quickly enough, measure the voltage input to the stove with all burners turned on and again with all burners turned off. If the difference between these two voltages is 10 or 15 volts, the power cable to the stove has defective connections or is not of large enough current carrying capacity.

Blown fuses sometimes do not visibly indicate they are burned out. With your 630-PL measure the voltage ahead and behind the fuse. Voltage ahead of the fuse but no voltage following indicates a blown, defective, or loose fuse. Sometimes it is easier to remove the fuse and measure its resistance. This should be substantially zero.

Your 630-PL is handy for locating trouble in desk and floor lamps. Pull the plug from the wall socket and check for a faulty cord, plug, switch, socket, or bulb by measuring resistance on the $\Omega \times 1$ range. 100 watt 120 volt bulbs should read 10 to 20 ohms. 50 watt 120 volt bulbs should read 20 to 40 ohms.

For the Radio Man

In addition to all common voltage, current, and resistance measurements used in servicing radios, the high sensitivity of your 630-PL is well adapted to measuring AFC, AVC, bias, and FM discriminator voltages.

Measurements of the high voltage up to 27,000 volts D. C. used in some television receivers for the picture tube can be effected with the special high voltage probe shown on page 20.

Considerable trouble is had with leakage in automobile radio antennas (due to moisture). Your 630-PL with the high ohm range 0-100 meg. is ideal to check this leakage. Disconnect the antenna from the receiver before making this check.

High frequency measurements are possible since the

If You Didn't Get This From My Site,
Then It Was Stolen From...

www.SteamPoweredRadio.Com

630-PL has a wide frequency response—usable from 10 cps to 500 Kc.

In The Industrial Plant

Your 630-PL will be a big help in checking voltage drop caused by adding that extra machine on the already overloaded line. Correcting this will often save time later when a rush comes and the line "just happens" to burn up.

Measure the voltage at the machine first with the machine turned off and again with the machine in operation. If the voltage is proper with the machine off but low with the machine in operation, the circuit wiring or transformers have too small a capacity. If the voltage is low even with the machine off, the circuit is probably already overloaded and the machine should be wired into another circuit.

Equipment using automatic electric controls can be checked with the 630-PL. Faulty relay or control action is often caused by low voltage applied to the relay or control. This low voltage in turn, may be caused by burned or dirty contacts on the control device. Use the $\Omega \times 1$ range to check for high or unstable contact resistance.

When a phone on your dial telephone system fails, measure the line current and the voltage to the particular relay in question. If the voltage is proper, measure the contact resistance of the relay contacts using the $\Omega \times 1$ scale on your 630-PL. If this resistance is over a fraction of an ohm or if the resistance seems to waver, clean and adjust the relay contacts.

In The Garage

Fuses in the automobiles have a tendency to look perfectly good and yet not function due to corrosion under the metal end cap. Measure voltage ahead and behind the fuse to determine a defective unit. Or remove the fuse and measure its resistance. Anything over a fraction of an ohm is too high.

Checking automobile wiring, light switches, heaters, radios, etc., can be speeded up by simple use of your 630-PL.

In The Laboratory

Your 630-PL is built with all precision, non-aging resistors. The specially designed switch and special banana type plugs insure lasting accuracy.

Special Applications

The unusually high range ohmmeter in your 630-PL permits some indication of condenser leakage resistance. Measure as a resistor, see page 10, using the highest range. A good paper or mica condenser under 1 mfd. will indicate at the 100 Meg mark or above. If a steady reading (taken after the initial surge required to charge the condenser) of less than 100 megohms is obtained, the condenser probably has defective insulation. Good paper condensers over 1 mfd. may read somewhat less than 100 megohms. Electrolytic condensers should read above .1 megohm. In checking electrolytic condensers, the black test lead ("com" jack) should be connected to the positive terminal of the condenser.

Checks of insulation resistance for motors, generators, telephone cables, power cables, etc., can be made on the high ohmmeter range of your 630-PL. The actual value of resistance may vary from a few megohms to over 100 meg, depending on weather conditions and quality of insulation. The best method, therefore, is to make periodic checks on important cables or equipment and observe the trend in readings. As the readings tend to be lower and lower, it is time to start drying out the equipment or determine the cause of deterioration. Dirt, mice, or foreign matter can sometimes cause excessive leakage.

Battery Replacement

Two batteries are used for the ohmmeter circuits, a 1.5 volt Eveready No. 950 or equivalent and a 30 volt Eveready No. 413 or equivalent.

When the meter pointer can no longer be adjusted to zero (see page 10) ohms on the $\Omega \times 1$, $\Omega \times 10$, or $\Omega \times 1000$ ranges, replace the 1.5 volt battery.

When the meter pointer can no longer be adjusted to zero ohms on the $\Omega \times 100,000$ range, replace the 30 volt battery.

To replace batteries, remove the four screws in the bottom of the case and lift panel from the case. Simply remove the old, and replace with a new battery being careful to observe polarity.

Care

A little precaution in handling and caring for your 630-PL can pay big dividends in satisfaction. Treat your tester like you would a fine watch.

Avoid placing your tester on a bench where machine tools are used or severe vibration is encountered.

Do not place your 630-PL near the edge of a shelf or bench where it can easily be knocked off.

When possible keep your 630-PL in a place of moderate temperatures. Avoid places with extreme temperatures or severe temperature changes.

In use, don't take chances on overloading the meter. If in doubt as to the approximate reading always start with the highest range.

Get in the habit of double checking the position of the switch before making a measurement. The meter can be burned out by applying voltage when the switch is set on the current or ohms scale.

If the unit has not been in use for a long period of time, rotating the switch in both directions several times will wipe the contacts clean for good contact.

Turn the selector switch to OFF when the unit is to be carried. The meter is damped in this position to prevent wild swinging of the pointer.

PARTS LOCATION

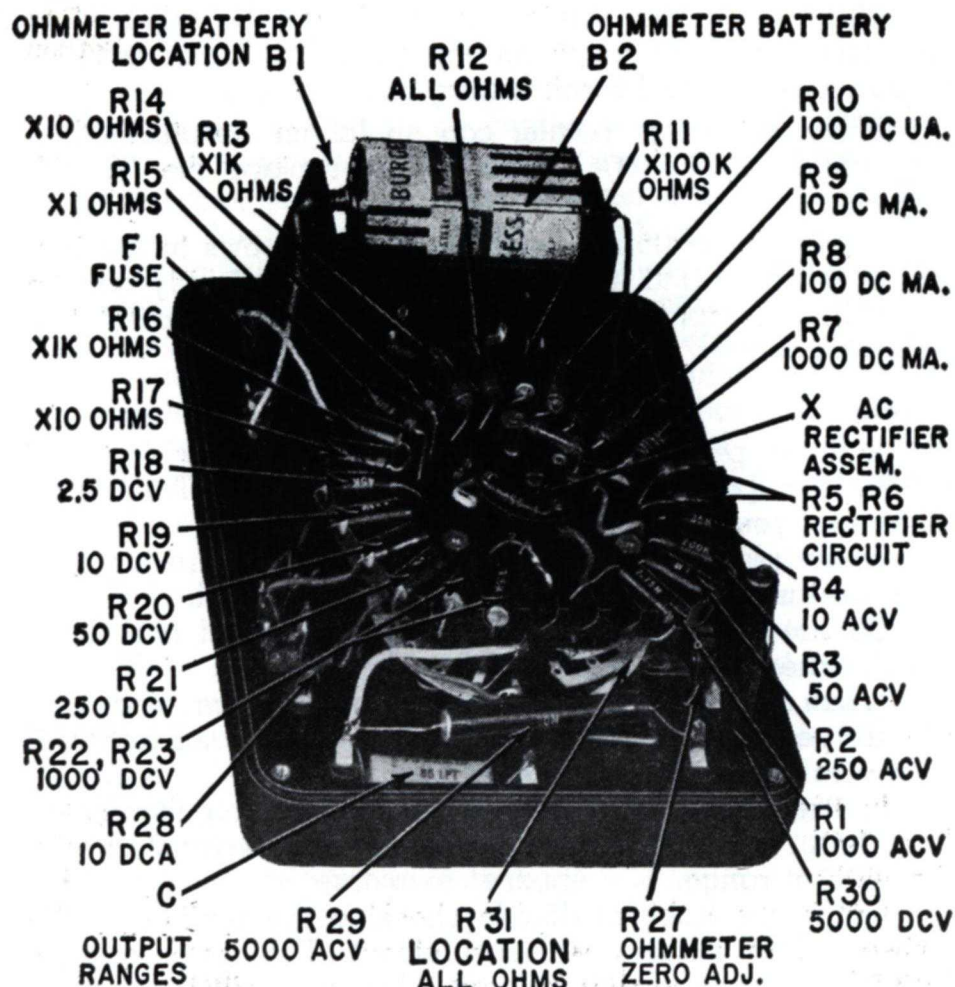

Figure 7

Ref. No.	DESCRIPTION		Part No. Req.
R1	Resistor	3.75 Meg., ±1%, ½ W, film type	T-15-2842
R2	Resistor	1 Meg., ±1%, ½ W, film type	T-15-1358
R3	Resistor	200K, ±1%, ½ W, film type	T-15-1061
R4	Resistor	35K, ±1%, ½ W, film type	T-15-2843
R5, R6	Resistor	5K, ±1%, ½ W, film type	T-15-1009
R7	Resistor	.25 ohms, ±1%, Wire type	15-2868
R8	Resistor	2.5 ohms, ±1%, Wire type	T-15-2869
R9	Resistor	25.12 ohms, ±1%, film type	15-2850
R10	Resistor	5K, ±1%, ½ W, film type	T-15-1009
R11	Resistor	423K, ±1%, ½ W, film type	T-15-4120
R12	Resistor	13.6K, ±1%, film type	T-15-1758
R13	Resistor	4690, ±1%, ½ W, film type	15-4118
R14	Resistor	37.2, ±1%, ½ W, film type	T-15-4116
R15	Resistor	3.7 ohms, ±1%, Wire type	T-15-3223
R16	Resistor	732, ±1%, ½ W, film type	T-15-4119
R17	Resistor	6.5 ohms, ±1%, Wire type	T-15-4117
R18	Resistor	45K, ±1%, ½ W, film type	T-15-1060
R19	Resistor	150K, ±1%, ½ W, film type	T-15-1763
R20	Resistor	800K, ±1%, ½ W, film type	T-15-1137
R21	Resistor	4 Meg., ±1%, ½ W film type	T-15-1138
R22 } R23 }	Resistor	7.5 Meg., ±1%, ½ W, film type	T-15-1262
R27	Resistor	20K, ±20%, Variable (with mtg. nuts & knob)	16-31
R28	Shunt Assem.	10 Amp	90A-449
R29	Resistor	20 Meg., ±1%, 2W	15-1674
R30	Resistor	60 Meg., ±1%, 2W	15-2844
R31	Resistor	5100, ±5%, ½ W	15-1411
C	Capacitor	.1 mfd., 400WV	T-43-69
B2	Battery	1.5 Burgess No. 2, NEDA No. 13	{ Available
B1	Battery	30V, Burgess, U20E, Eveready 413, or NEDA No. 210	{ Locally
M	Meter	50 Micro-Amps, 250 Millivolts	52A-3065
X	Rectifier assembly		2250A 30
X2	Diode	Meter protection	11670
S1	Switch	20 Pos., 4 deck, without resistors	22A 319
	Switch	20 Pos., 4 deck, with resistors	22-320
S2	Switch	Slide, DPDT (Wirt SW726)	T-22-152
	Knob	Scarlet, 2 5/16 long with clip	34 B-62
	Case	with handle	T-10-784
	Jack	contact	8944
	Clip	shunt retaining No. C2416-012-27	T-2451-6
	Bumper	rubber	T-3236-10
	Leads	Banana Type	T-79-127
	Front	Clear plastic with zero adj.	10A-2212
F1	Fuse	1 Amp. Littlefuse, 3AG, 312001	3207-15

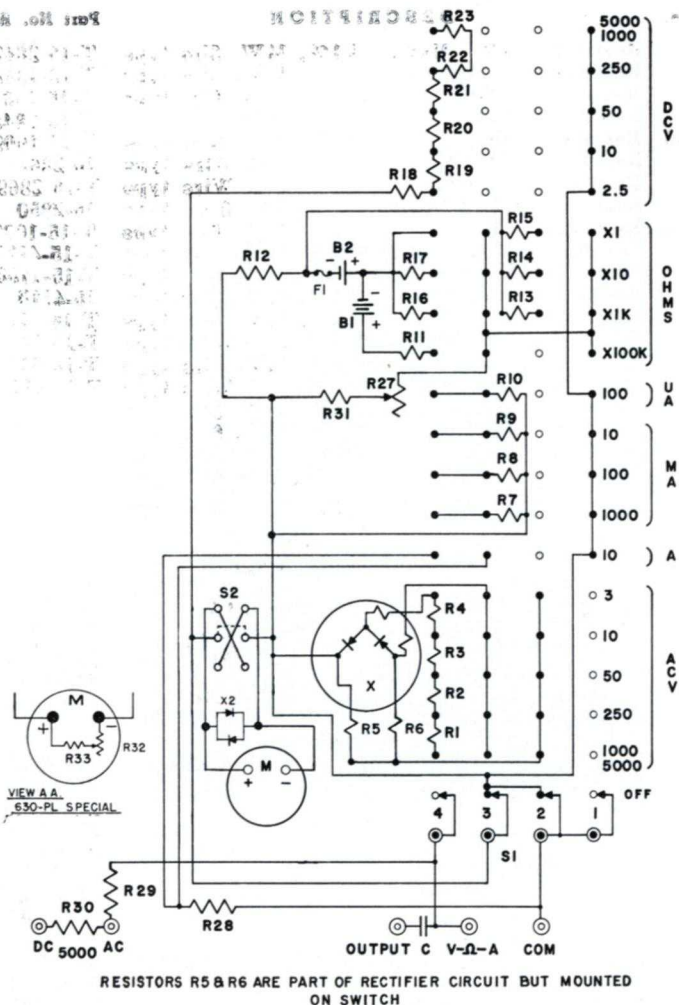

Figure 8—Circuit Diagram

DB CHART

0 DB at 1 Mw
Decibels with
600 ohm line

Line Power
Mw

RMS Volts with
line Imped. of
600 ohms

-20	.01	.0775
-10	.1	.245
-5	.316	.436
0	1.00	.775
+10	10.0	2.45
+15	31.6	4.36
+20	100	7.75
+30	1000	24.5
+40	10,000	77.5
+50	100,000	245.
+60	1,000,000	775.
+70	10,000,000	2450

Note:

The range of audibility can be considered to lie from 70 db below the normal speech level to 70 db above the same level, or a total range of 140 db.

EIA MICA CONDENSER COLOR CODE

Color	MOLDED PAPER		MOLDED MICA		CERAMIC	
	Multiplier	Tolerance	Multiplier	Tolerance	Multiplier	Tolerance
Black	1	20%	1	20%	1	20% or 2.0 μ fd.*
Brown	10		10		10	1%
Red	100		100	20% EIA	100	2%
Orange	1000		1000	3% EIA	1000	2.5% EIA
Yellow	10,000	5%	10,000		10,000	
Green				5% EIA		5% or 0.5 μ fd.*
Blue						
Violet						
Gray					0.01	0.25 μ fd.*
White		10%	0.1	5% (JAN)	0.1	10% or 1.0 μ fd.*
Gold	0.1	5%				
Silver		10%	0.01	10%		
None		20%				

* Capacitance less than 10 μ fd.

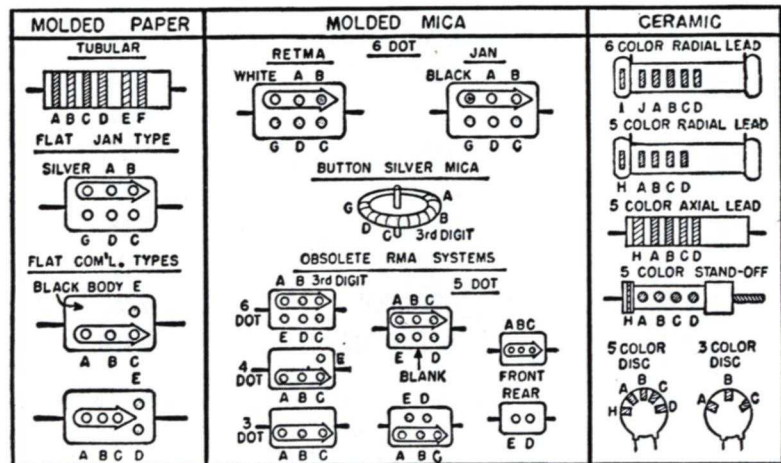

(Courtesy Popular Electronics)

Capacitance is given in μ fd.

Colors—Same value as on resistors except as indicated in tables.

COLORS

- A
- B
- C
- D
- E & F

INDICATES

- First digit
- Second digit
- Multiplier
- Tolerance
- Voltage Rating in hundreds of volts

[(E) Ratings less than 1000 volts, (E) & (F) First two digits of ratings 1000 volts or more. Values of colors for (E) & (F) are same as in resistance values. (G) is class or characteristics of capacitor. (H), (I) & (J) give temperature coefficient. (G), (H), (I) & (J) are not listed in the tables.]

If You Didn't Get This From My Site,
Then It Was Stolen From...

EIA RESISTOR COLOR CODE

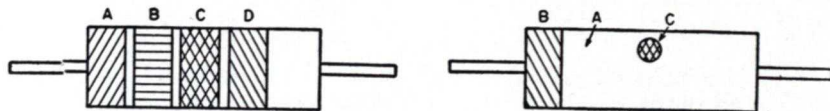

Color

- A
- R
- C
- D

Indicates

- First number
- Second number
- Number of zeros
- Tolerance

Color

Number

- Black
- Brown
- Red
- Orange
- Yellow
- Green
- Blue

- 0
- 1
- 2
- 3
- 4
- 5
- 6

The resulting value is in ohms.

Color

Number

- Violet
 - Gray
 - White
 - Gold
 - Silver
 - None
- 7
 - 8
 - 9
 - 5% tolerance
 - 10% tolerance
 - 20% tolerance

Example:

A 250,000 ohm 20% resistor.

A red B green C yellow D no color

EIA SPEAKER COLOR CODE

Voice—Coil:
Green—finish
Black—start

Field Coils:
Black and red—start
Yellow and red—finish
Slate and red—tap (if any)

EIA WIRING COLOR CODE

B+	-	-	-	-	-	Red
Ground	-	-	-	-	-	Black
Plate	-	-	-	-	-	Blue
Grid	-	-	-	-	-	Green
Cathode	-	-	-	-	-	Yellow
High Heater	-	-	-	-	-	Brown
Low Heater	-	-	-	-	-	Black
Screen Grid	-	-	-	-	-	Orange
AVC	-	-	-	-	-	White

EIA TRANSFORMER COLOR CODE

I. F. Transformers:

Blue—plate lead
 Red—"B" + lead
 Green—grid (or diode) lead
 Black—grid (or diode) return

NOTE: If the secondary of the i. f. t. is center-tapped, the second diode plate lead is green-and-black striped, and black is used for the center-tap lead.

Power Transformers:

1. Primary Leads Black
 If tapped:
 Common Black
 Tap—Black and Yellow
 Striped Finish—Black and
 Red Striped
2. High-Voltage Plate Wind-
 ing Red
 Center-Tap — Red and
 Yellow Striped
3. Rectifier Fil. Winding . . .
 Yellow
 Center-Tap—Yellow and
 Blue Striped
4. Fil. Winding No. 1. Green
 Center-Tap — Green and
 Yellow Striped
5. Fil. Winding No. 2. Brown
 Center-Tap — Brown and
 Yellow Striped
6. Fil. Winding No. 3. Slate
 Center-Tap — Slate and
 Yellow Striped

A. F. Transformers:

- Blue—plate (finish) lead of
 primary
 Red—"B" + lead (this ap-
 plies whether the primary
 is plain or center-tapped).
 Brown—plate (start) lead on
 center tapped primaries
 (Blue may be used for
 this lead if polarity is not
 important.)
 Green—grid (finish) lead to
 secondary
 Black—grid return (this ap-
 plies whether the second-
 ary is plain or center-
 tapped.)
 Yellow—grid (start) lead on
 center tapped second-
 aries. (Green may be used
 for this lead if polarity is
 not important.)

Note: These marking ap-
 ply also to line-to-grid, and
 tube-to-line transformers.

If You Didn't Get This From My Site,
Then It Was Stolen From...

www.SteamPoweredRadio.Com