

AUDIO SIGNAL PROCESSING

If You Didn't Get This From My Site,
Then It Was Stolen From...

www.SteamPoweredRadio.Com

 **Symetrix**

The Company

About Symetrix

SYMETRIX, INC. is a world leader in professional analog and digital audio signal processing. Our products are designed to the highest standards of audio quality, reliability, and ease of use. Located in Lynnwood, WA, USA, we are a group of musicians, engineers, audiophiles, and support staff who enjoy their work immensely. For example, our six man engineering team has a collective work history of over 70 years with Symetrix and other professional audio companies. We shipped our first noise gate in 1976, almost 19 years ago! Over 100,000 units later, we can proudly say **"Symetrix is in it for the long haul"**.

Our products have gained an international following from sound professionals doing business in recording, broadcast, film & video post production, live sound, and installed systems. From major broadcast networks to private project studios, Symetrix gear is working day in and day out to get the job done. Although our customer base is broad, we're not side-tracked by trying to be all things to all people. We're focused on one and only one discipline: digital and analog signal processing. Our products are manufactured in a modern, automated state-of-the-art factory. We maintain complete control of all processes and components from initial design through final test and shipment. This ensures that a customer who chooses Symetrix undoubtedly receives the maximum in value for money spent.

What's in this catalog

This catalog contains information on our full line of professional products. We've provided detailed information including basic features, product descriptions, application suggestions and technical specifications for all products including accessories. It is our intention to provide real world solutions to your audio needs. While we have made every effort to make the information contained in the catalog as complete as possible, we stand ready to provide answers to any additional questions you may have.

How to get more information

Our products are distributed throughout the world by a dedicated network of representatives, dealers and distributors. In the US contact us at 1-206-787-3222 for applications information or the name of a Symetrix dealer near you. Outside of the US you will most likely find Symetrix products distributed by one of the companies listed on the inside back cover of this catalog. If your country is not included in the list, please call or FAX our headquarters directly for information on how to obtain our products in your country.



Dane Butcher, President



620 20 Bit A/D Converter

20 bit quantization;
dither and noise shape

Quantización de 20 bits;
conformación de oscilación
de pequeña amplitud y ruido.

Quantification 20 bit;
noise shape et dither.

20 Bit Quantisierung;
"Dither-" und "Noise Shaping".



610 Broadcast Audio Delay

Seven seconds profanity delay;
advanced DSP "time expand/
time squeeze" stereo, 14 kHz
bandwidth

Máximo tiempo de retardo de 7
segundos para supresión de
mensajes de oyentes que no se
desea que salgan al aire. DSP
avanzado "expansor de tiempo/
reductor de tiempo"; estéreo,
anchura de banda 14 kHz.

Délai d'inhibition (profanity)
de 7 secondes; DSP évolué,
expansion et compression
temporelle.

Spezial-Delay für Rundfunkanwen-
dungen zum Ausblenden uner-
wünschter Programmphasen;
Delayzeit max. 7.5 Sek-unden,
sukzessive Regelung der Delayzeit
(DSP kontrolliert, nicht wahrnehmbar);
Stereo, 14 kHz Bandbreite.



601/602 Stereo Digital Processors

Parametric EQ, dynamics
processing, delay; MIDI

Amiento dinámico,
delay; MIDI.

EQ paramétrique, traitement
de dynamique, ligne de retard;
MIDI.

EQ; dynamisches Processing;
Delay; MIDI.



572 SPL Computer

Automatic gain controller uses
system speakers to sense
ambient changes

Controlador automático de
ganancia. Usa los altavoces
para detectar cambios en el
ambiente.

Contrôleur de gain automatique
utilise les haut-parleurs pour
détecter les changements de
niveau ambiant.

Automatische Verstärkungs-
regelung abhängig von der
Umgebungs Lautstärke, Messung
über Systemlautsprecher.



571 SPL Computer

Automatic gain controller
uses microphone to sense
ambient changes

Controlador automático de
ganancia. Usa micrófono
para detectar cambios en
el ambiente.

Contrôleur de gain automatique
utilise deux microphones pour
détecter les changements de
niveau ambiant.

Automatische Verstärkungs-
regelung abhängig von der
Umgebungs Lautstärke, Messung
mit Sensing-Mikrofonen.



564E Quad Expander/Gate

"Frequency conscious"
gating, instantaneous
attack time

Circuito "sensible a la
frecuencia". Tiempo de
ataque instantáneo.

Quadruple noise-gate/
expandeur sélectif en fréquence.
Temps d'attaque extrêmement
courts.

Frequenzabhängiges Gate,
schnelle Attackzeiten.



528E Voice Processor

Mic preamp, de-esser,
compressor, expander,
parametric EQ - all in one .

Previo de micro, de-esser,
compresor, expansor, EQ
paramétrico — todo en uno.

Préampli micro, de-esser,
compresseur, expandeur/gate,
paramétrique 3 bandes.

Mic-Vorverstärker, De-Esser,
Kompressor, Expander,
parametrischer EQ.



501 Peak-RMS Compressor/Limiter

Single channel simultaneous
peak and RMS processing

Procesamiento mono,
simultáneo de pico y RMS.

Compresseur-limiteur mono,
traitement RMS et crête de
la modulation.

Gleichzeitiges Processing auf
Spitzen- und RMS-Werten.



488 DYNA-Squeeze™

8 channel compressor/interface
for digital 8-track recorders

Compresor/ "interface" de
8 canales para grabadoras
de 8 pistas digitales.

Compresseur 8 canaux; permet
également d'interfacer les
enregistreurs 8 pistes.

8-Kanal Compressor/Interface
für digitale 8-Spur-Recorder.

If You Didn't Get This From My Site,
Then It Was Stolen From...

www.SteamPoweredRadio.Com

contents

Contents

450 Mic/Line Mixer

Separate stereo and mono output zones; 4 stereo inputs, 2 mic inputs

Zonas de salida estéreo y mono separadas; 4 entradas estéreo, 2 entradas de micro.

Sorties zones stéréo et mono séparées; 4 entrées stéréo, 2 entrées micro.

Getrennte Stereo- und Mono-Ausgangszonen; 4 Stereo-Eingänge, 2 Mikrofon-Eingänge.



425 Dual Compressor/Limiter/Expander

Dual mono or stereo linked operation

Funciona conectado en dual-mono o en estéreo.

Double compresseur-limiteur/expandeur-gate, mode stéréo ou deux canaux indépendants.

Betrieb als dual-Mono oder linked-Stereo möglich.



422 Stereo AGC-Leveler

Reduces the level of loud sounds, increases the level of quiet sounds; stereo inputs and outputs

Reduce el nivel de sonidos altos, incrementa el nivel de sonidos bajos; entradas y salidas estéreo.

Réduit le niveau des sons forts, accroît le niveau des sons faibles; entrées et sorties niveau ligne stéréo.

Reduziert hohe Signalpegel, hebt niedrige Pegel an; Stereo-Ein- und Ausgänge.



421m AGC-Leveler with Mic/Line Input

Reduces the level of loud sounds, increases the level of quiet sounds; mic or line input

Reduce el nivel de sonidos altos, incrementa el nivel de los sonidos bajos; entrada micrófono o línea.

Réduit le niveau des sons forts, accroît le niveau des sons faibles; entrée micro ou ligne.

Automatische Verstärkungsregelung, Verstärkung von kleinen Pegeln und Abschwächung von hohen Pegeln.



420 Stereo Power Amplifier

20 watts/channel into 8 ohms or 40 watts/mono into 8 ohms

20 W/canal a 8 Ohms. o 40 W/mono a 8 Ohms.

Amplificateur stéréo 2x20 Watts/8 ohms, 40 Watts mono bridgé a 8 ohms.

20W an 8 Ohm pro Kanal; mono; 40W an 8 Ohm.



402 Dual Output Delay

One in, two out precision delay of distant speakers; over 100dB dynamic range

1 entrada, 2 salidas con retardo o delay de precisión para altavoces distantes. Gama dinámica superior a 100 dB.

Délat numérique 1 entré vers 2 sorties. Dynamique supérieure à 100 dB. Cohérence en phase excellente.

1 Ein- und 2 Ausgänge; präzise Einstellung der Verzögerungszeit in ft, m, s; über 100 dB Dynamikbereich.



SX208 Stereo Compressor/Limiter

Low cost, easy to use, superb sound

Bajo costo, fácil de usar, extraordinario sonido.

Un rapport qualité/prix imbattable pour des performances excellentes.

Preisgünstig; einfache Handhabung; sauberer Klang.



SX204 Headphone Amplifier

Four outputs with individual level controls, stereo or mono inputs

Cuatro salidas con controles individuales del nivel, entradas estéreo o mono.

Quatre sorties avec contrôles de niveau individuels, entrées mono ou stéréo.

Stereo- oder Mono-Eingang; Vier getrennt einstellbare Ausgänge.

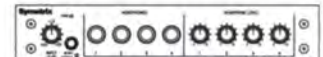

SX202 Dual Microphone Preamp

Phantom power, 15 dB pads, polarity reversal

Alimentación Phantom. Atenuación de 15 dB, inversión de polaridad.

Double préampli micro, ou mélangeur 2->1 sortie ligne. 48V commutable, inversion de phase, pad de 30 dB.

Phantomspannung; 15 dB-Absenkung pro Kanal; Polaritätsumschalter.



SX201 Parametric EQ/Preamp

Three overlapping EQ/notch filter bands with preamp

Tres bandas de EQ/notch filter solapadas con previo.

Égaliseur paramétrique mono 3 bandes (-30/+15 dB, Q 0,05 à 3,3) + préampli micro.

Drei überlappende EQ-/Notch-Filter mit Vorverstärker.



620 20 Bit A/D Converter



WANT TO KNOW A SECRET? It's not a 16 bit world anymore. While it's true that your DAT recorder is most likely 16 bit, your hard disk recorder/editor is probably 16 bit, your CD player is certainly 16 bit, your ears (depending upon your age and the number of metal concerts you've been to), could well be in the 22 bit range! Transferring audio from the analog to the digital domain is a critical process – not to be taken lightly if you strive for high quality output from your studio. If your recorder or workstation stores 16 bit audio, you must make sure that your A/D converter uses each and every one of those bits in the most effective way. The converter must be greater than 16 bits and must incorporate intelligent dithering and noise shaping. If your ears can hear more than 16 bits, there's no reason to continue with a 16 bit A/D converter.

The **Symetrix 620** is an outboard 20 bit A/D converter for faultless transitions between analog and digital domains. If you're presently using a 16 bit recorder or workstation, the 620's dither and noise shaping functions can markedly reduce your low level noise and distortion. If you've already moved up to 20 bit equipment, then chances are good the 620 will provide a clearly audible improvement over your internal A/D converters.

How exactly, can the 620 improve the sound of my 16 bit mixes? Although 16 bits can theoretically give you 96 dB of dynamic range, the fact remains that low level signals are not well represented by the lower bits of a 16 bit word. One of the advantages of analog tape was that low level audio could fall below the recorder's noise floor and still be discernible. Not so with digital. Undithered signals that fall below the digital 'quantization' level are lost and gone forever, covered over by quantization noise. If your console boasts a 110 dB dynamic range and you mix to a 16 bit DAT (even if it's equipped with an 18 bit converter), your dynamic range is reduced to 96 dB at best. Even if you feed your DAT digitally from a 20 bit A/D, the DAT will simply throw away (truncate) the last four bits. No questions asked.

Our solution is to capture the detailed analog audio (which in many cases has well over 110 dB of dynamic range) and intelligently process it into the 16 bit storage medium. The 620 does this through use of dither and noise shaping. The 620's dither algorithm (D16) improves the effective dynamic range of 16 bit sounds (or 8 bit if you're working in multimedia), by changing the characteristic of quantization noise from a harsh, signal related distortion to a smooth hiss. The D16 algorithm is used when the signal is headed for further digital domain processing such as editing, compression, EQ, etc.

If you're mixing to your final destination (such as DAT) and your signal will undergo no further digital processing, select the NS16 algorithm which is a combination of dither and noise shaping. When converting from 20 to 16 bit resolution the 620's noise shaper moves the quantization noise out of the midrange region where the human ear is most sensitive. (See graphs on the reverse of this page.)

What sets the 620 apart from the internal A/D converters that came with my equipment?

Lots of things. Most internal A/D converters are 'bare bones'. The 620 carefully integrates a 20 bit delta-sigma IC with a powerful DSP processor to noise shape, dither (technically re-dither), downsample (44.1 to 22.05 conversion) and remove DC in the digital domain. While the advantages of the 620 are numerous, the bottom line is the sound. If you do sound for a living, then do something nice for yourself. Call us at one of the numbers below for more information and a list of Symetrix 600 series dealers. We think you'll be glad you did.

Features

- 20 bit quantization
- Selectable dither & noise shape
- Selectable output word size
- AES/EBU & S/P DIF in and out
- Real time sample rate conversion from 44.1 to 22.05 for multimedia

Applications

MIXING TO DAT

CD MASTERING

SAMPLE LIBRARY MASTERING

MULTI MEDIA MASTERING

OUTBOARD A/D FOR HARD DISK & MODULAR DIGITAL MULTI-TRACKS

620

620 20 Bit A/D Converter

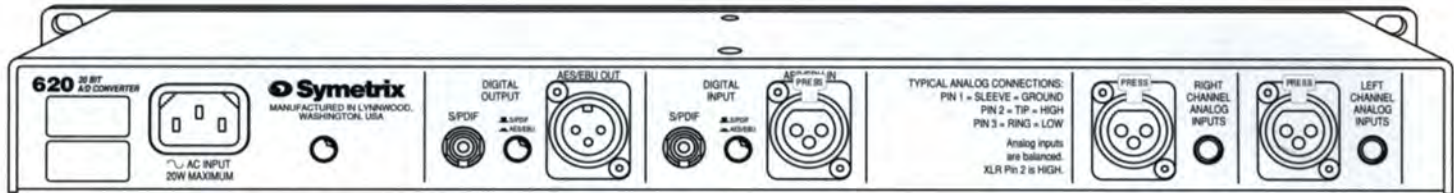

Specifications

Audio

Quantization	20 bits/sample
Analog Inputs	two, balanced bridging
Maximum analog input level	+24 dBu, balanced +16 dBu, unbalanced
Digital Inputs	AES/EBU and S/P DIF (Sony/Phillips)
Digital Outputs	AES/EBU and S/P DIF (Sony/Phillips)
Frequency Response	±.5dB, 20 Hz-20 kHz
THD+noise @ -60 dBFS (-38 dBu)	>104 dBFS
Dynamic Range	see graph below
Crosstalk@1kHz,+22 dBu input	<-95 dB
Common mode rejection @1kHz, 1v RMS	>85 dB
Sample rates:	48 kHz, 44.1 kHz, 32 kHz, 22.05 kHz
Headroom LEDs:	-54 dBFS to 0dbFS (clip)

Physical

Analog Inputs	XLR (pin 2 high) and 1/4" tip-ring-sleeve
Digital Input & output connectors	XLR (AES/EBU) and RCA pinjack (S/P DIF)
Chassis size	1.75"H x 19" W x 7.5" D 4.45cm H x 48.3cm W x 19.1cm D
Shipping weight	8 lbs, 3.64kg

Electrical

Power	117V ac, nominal, 95-130V ac, 50-60Hz 230V ac, nominal, 165-255V ac, 50Hz
Power Consumption	20 watts, maximum

In the interest of continuous product improvement, Symetrix, Inc. reserves the right to alter, change, or modify these specifications without prior notice. Copyright, 1995, Symetrix, Inc. All rights reserved.

Highlights

Non-polluting. No phosphates or distortion-causing capacitors in the signal path. Audio pollution banished. Instead of capacitors for DC removal, we annihilate DC with a digital filter.

Safe for use in low noise environments. Dynamic range? Look at the 20 bit FFT below. Noise in every bin is better than 135 dB below full scale! Check out the 16 bit noise shape graph on the right. Is the 620 quiet enough for *your* DAT?

Dolphin Friendly. Logical, easy to use control panel. Lots of LEDs to show you exactly what's happening at all times. Batteries not included. The 620 doesn't need batteries. All settings are stored in a nonvolatile EEPROM.

Politically and aurally neutral. The 620 has no association with any known political party, special interest group, or trendy sound. That means you can use it on *any* project without fear of recrimination.

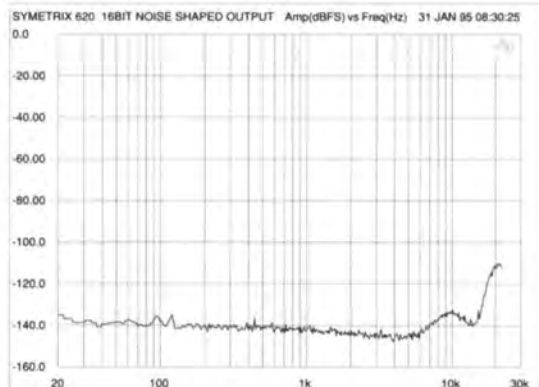
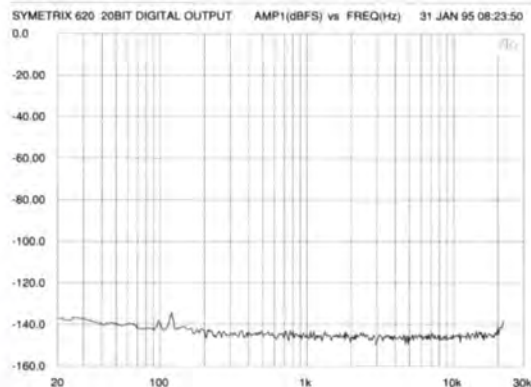

Architects and Engineers Specifications

The analog to digital converter shall be a high performance unit occupying a single rack space (1U).

The unit shall have two line level, balanced, analog inputs. Input gain shall be controlled via two variable potentiometers over a 15dB range. Alternatively, a fixed input gain reference of +4dBu may be selected.

The A/D converter shall provide a digital output signal conforming to the AES/EBU digital audio format (AES-3) as well as a second digital output conforming to the S/P DIF format (IEC-958).

The unit shall internally generate sample rates of 48kHz, 44.1kHz, 32kHz, and 22.05kHz. When converting from analog to digital, the converter shall quantize 20 bits.

Means shall be provided to select the following output word formats: 20 bit, 16 bit dithered (using a triangular probability random noise generator), 16 bit noise shaped and dithered, 8 bit noise shaped, and 8 bit dithered.

The A/D converter shall provide means to accept incoming digital audio signals at a 44.1kHz sample rate and output the same signals at a 22.05kHz sample rate.

The A/D converter shall be a Symetrix, Inc. model 620 20 bit A/D converter.

620

Symetrix

www.SteamPoweredRadio.Com

Symetrix Inc. • 14926 35th Ave. W. • Lynnwood, WA 98037 • USA • Tel: (206) 787-3222 • FAX: (206) 787-3211 • e-mail: 102102.1126@compuserve.com

610 Broadcast Audio Delay



THE SYMETRIX 610 BROADCAST AUDIO DELAY gives the host or producer of a talk show the power to prevent the broadcast of unwanted profanities or comments from telephone callers. As the program begins, the 610 gradually and unobtrusively delays or 'stretches out' the program until 7.5 seconds of 15 kHz bandwidth stereo audio is stored in memory. When a person on the telephone line says something the host or producer does not think appropriate for the broadcast, he or she presses the 'DUMP PROFANITY' button and the memory is cleared, thereby preventing the unwanted audio from reaching the airwaves. Meanwhile, the host releases the offending caller from the telephone line and proceeds with the program. Once the 'DUMP PROFANITY' button is pressed, the 610 automatically begins to stretch the program audio again until the full 7.5 second delay is attained.

Historically, broadcast delay lines have been implemented in a variety of fashions, from jerry-rigged analog tape delays using tricky relay switching, to extremely expensive digital units costing many thousands of dollars. The Symetrix 610 takes advantage of the latest digital audio technology to bring to market a product that is both simple to install and amazingly easy for even the most nontechnical person to operate. All of this, at a price that's within the budget of any broadcast facility.

The advantages of installing a 610 in your facility are at least twofold: 1) profanities and unwanted comments and their accompanying liabilities are held at bay and 2) your station's talent, programming and engineering staff can proceed to do their jobs with confidence and peace of mind.

In a typical scenario, the 610 is installed following the main program output of the mixing console. When the show begins, the host or producer presses the 'START DELAY' button. The 610 inserts imperceptible delays into the program until a 7.5 second delay time has been reached. As explained above, should an unwanted comment occur, the 'DUMP PROFANITY' button is pressed and 7.5 seconds of audio vanishes taking the comment with it. The 610 automatically splices back together everything except the 7.5 seconds which contained the unwanted comment. Alternatively, the 610 can be set up so that only half of the 7.5 second memory is deleted the first time the button is pushed, thereby maintaining a 3.75 second reserve. This allows the host to bring another caller on air right away without having to wait for the memory to build up from scratch – a great feature for fast moving shows! Just

prior to the end of the program the 'EXIT DELAY' button is pushed. The 610 begins releasing memory gradually until there is no delay and operation is in real time. It's that simple.

As a bonus feature we've added a 'COUGH' button to allow the host to make impromptu interruptions of the program for up to 7.5 seconds while keeping the audience unaware of the break. In this situation the button is pushed and the 610 plays from memory while the button is held in. As soon as the button is released, the 610 automatically begins to refill the memory. The host can cough, have a quick drink of water, or make a comment to the producer or engineer without any perceptible program interruption.

As with all Symetrix products the 610 Broadcast Audio Delay is designed and constructed to the highest broadcast industry standards. Our documentation and customer support are second to none. If your station's programming includes 'talk' and you want to operate with confidence, then contact your favorite equipment distributor for a demonstration of the 610 Broadcast Audio Delay.

Features

- **Advanced DSP 'time expand/time squeeze'**
- **Simple, fool-proof controls – easy to operate**
- **Remote control of all functions and important LED indicators**
- **'Hardwire' relay bypass (failsafe)**
- **Bullet-proof & built to last**
- **Stereo, 14 kHz bandwidth**

Applications

NEWS/TALK RADIO

SPORTS RADIO

MUSIC FORMATS

AM OR FM

Any situation where live or taped telephone conversations are broadcast

610

610 Broadcast Audio Delay

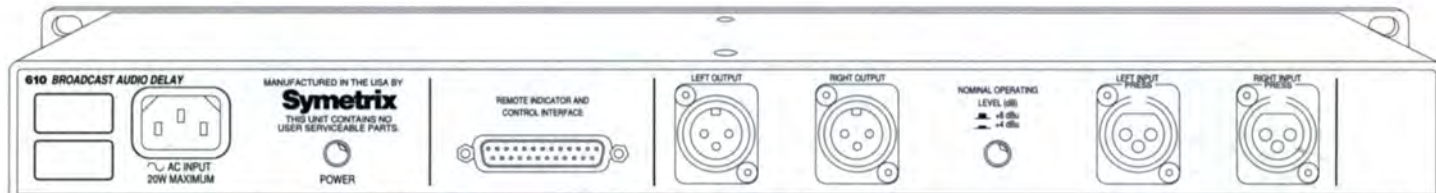

Specifications

Audio

Inputs	Stereo, balanced bridging
Outputs	Stereo, electronically balanced
Maximum input level	+22 @ 8dBu input setting
Maximum output level	+22 dBu into 600 ohms
Frequency Response	± 0.5 dBu, 20 Hz-14 kHz
Dynamic Range	>80 dB
Input common mode rejection	65 dB @ 1kHz

Physical

Input connectors	XLR
Output connectors	XLR
Polarity	Pin 2 high
Chassis size	1.75" H x 19" W x 7.5" D 4.45cm H x 48.3cm W x 19.1cm D
Shipping weight	8 lbs, 3.64kg

Electrical

Power	117V ac, nominal, 105-130V ac, 50-60Hz 230V ac, nominal, 207-255V ac, 50Hz
Power Consumption	15 watts, maximum

In the interest of continuous product improvement, Symetrix, Inc. reserves the right to alter, change, or modify these specifications without prior notice.
Copyright 1995, Symetrix, Inc. All rights reserved.

Architects and Engineers Specifications

The Broadcast Audio Delay shall be a stereo model whose output is delayed by as much as 7.5 seconds thereby allowing the operator to delete or 'dump' unwanted audio. The Broadcast Audio Delay shall occupy one rack space (1U).

The inputs shall be active balanced bridging designs terminated with 3-pin XLR (AES/IEC standard wiring) female jacks.

The outputs shall be active balanced designs terminated with 3-pin XLR (AES/IEC standard wiring) male jacks.

Overall frequency response shall be 20Hz to 14kHz, ± 1 measured at +4dBu output. There shall be no more than 0.1% harmonic distortion measured under the following conditions: +4dBu input, +4dBm output, 7.5 second delay, 1000Hz test frequency. Dynamic range shall be >80 dB, full scale, between the noise floor and maximum output level.

When the unit is inoperative (either by loss of power, or via the BYPASS switch), the inputs and outputs shall be wired together.

The Broadcast Audio Delay shall be capable of operating by means of its own built-in power supply connected to 117V nominal AC (105 to 130V) 50/60 Hz and 230V nominal AC (207 to 253V AC).

The Broadcast Audio Delay shall be a Symetrix, Incorporated model 610 BROADCAST AUDIO DELAY.

610

Symetrix

www.SteamPoweredRadio.Com

Symetrix Inc. • 14926 35th Ave. W. • Lynnwood, WA 98037 • USA • Tel: (206) 787-3222 • FAX: (206) 787-3211 • e-mail: 102102.1126@compuserve.com

601/602 Stereo Digital Processors



THE SYMETRIX 602 STEREO DIGITAL PROCESSOR and 601 DIGITAL VOICE PROCESSOR are digital domain audio toolboxes, each providing three essential processing blocks in one user-friendly package: parametric EQ, multi-dynamics processing, and time domain effects—all simultaneously. Designed for studio and live sound professionals, the 601 and 602 feature digital (AES/EBU and S/PDIF) and analog inputs and outputs, a dynamic range over 100 dB, and comprehensive real-time MIDI implementation.

The processing includes a three band parametric EQ with peak/shelf and notch filtering, a compressor/limiter, an AGC/leveler, a downward expander, dynamic filter noise reduction, de-essing, and stereo digital delay with modulation and feedback. "Glitch-free" non-zippering algorithms are coupled with seamless, on-the-fly editing and program changes. For example, as you change programs there are no crossfades or muting. Would you like to change EQ frequencies in the middle of a take? No problem. The 601 and 602 do it silently. A powerful dual-DSP engine was designed to provide users with a digital tool that maintains the purity of sound in the finest analog designs while taking full advantage of digital programmability.

Choose from 128 read-only presets for voice, instruments and spatial manipulation or store your own programs in 128 user locations. The read-only presets range from subtle enhancement EQ curves with complementary dynamics processing to full-blown "Darth Vader" transmogrifications. Get up and running instantly with the non-volatile presets then modify them and store them as your own proprietary sound designs. To protect your work, the entire contents of memory can be easily dumped via MIDI to floppy or hard disk.

With the intuitive user interface even the novice user can take command in a matter of minutes. You don't have to navigate through a complex multi-layer menu to operate a 601 or 602. We've incorporated a "one button, one function" approach that offers instant access to all major parameters and functions.

18-bit 64X oversampling A/D converters and a 24-bit internal data stream provide mastering quality audio performance that will please the most discerning "golden ear". 18-Bit Delta-Sigma D/A converters insure high-frequency linearity and zero-phase error between channels. Our stringent standards of circuit board design have produced a product with over 100 dB dynamic range. Go ahead and crank up the gain. Even

your low level signals will come shining through—no whistles or birdies—just good, clean sound.

So what's the difference between the 601 and 602?

The 601 is equipped with a mic input (with phantom power) and a line input and designed for post-production, broadcast, or anywhere rack space and convenience are paramount. The 602 has two line inputs and no mic preamp and serves as a general purpose mastering and studio processing tool, however, its stereo analog inputs make it useful for a wide range of tasks. Both units have stereo digital inputs and outputs, stereo analog outputs, and identical processing functions.

We have also developed the 601/602 Librarian/Controller software for Macintosh computers, which is essentially an onscreen, click and drag, scroll bar version of the units' front panels. The librarian feature allows you to store your presets on the Mac, edit them with the editor/controller, rename them, and move them around in memory.

The 601 and 602 from Symetrix represent a milestone in terms of signal processing power for money spent. Taking the place of at least four separate signal processing devices in your rack, they can increase your studio's production efficiency and help you generate better mixes. To see for yourself, contact your nearest Symetrix dealer.

Features

- AES/EBU & S/PDIF stereo in and out
- Simultaneous true stereo digital EQ, dynamics, & delay
- MIDI control of all programs & parameters
- "Glitch-Free" instantaneous program change
- 601/602 Librarian/Controller software for Macintosh computers

602 Applications

STUDIO DIGITAL MASTERING PROCESSOR

BROADCAST PROGRAM OPTIMIZER

FILM/POST MIDI CONTROLLED EFFECTS PROCESSOR

GENERAL PURPOSE DIGITAL "FIX-IT" KIT

601 Applications

VOICE-OVER MIC PROCESSOR

BROADCAST ON-AIR MIC PROCESSOR

GOLDEN VOICE LIVE PERFORMANCE PROCESSOR

DIGITAL STUDIO MIC/LINE PROCESSOR

DIGITAL WORKSTATION "FRONT END"

602

Symetrix

601/602 Stereo Digital Processors

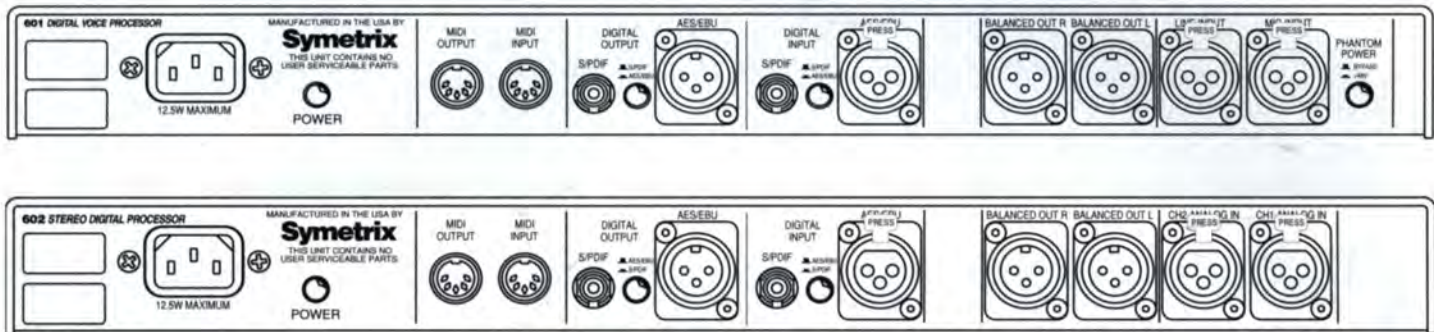

Specifications

Input/Output

601 & 602 Analog Inputs	XLR-female, >9 kilohms, line level, balanced
601 Additional Analog Inputs	XLR-female balanced microphone input (48V nominal phantom power), 15 dB pad
Digital Inputs	XLR-female and RCA-female, AES/EBU or S/PDIF
Analog Outputs	300-ohm source impedance, balanced, XLR-male
Digital Outputs	XLR-male and RCA-female, AES/EBU or S/PDIF
Maximum Input Level	+22 dBu
Maximum Output Level	+21.5 dBu

Filter Block

Type	Three-band parametric EQ (1/10 octave ISO center frequencies)
Peak Characteristic	31 Hz to 21.11 kHz, peak and dip
Shelving Characteristic	31 Hz to 21.11 kHz, Baxandall approximation
Peak/Dip Bandwidth	0.05 to 3 octaves, measured at maximum boost

Delay Block

Delay Time	0.5 ms to 330 ms
Lowpass Filter Frequency	600-18 kHz (feedback path only)
Modulation	Random, sine, or triangle wave
Dynamics Block Types	De-essing, dynamic filter noise reduction, downward expansion, compression, AGC/leveling
Compression Ratio	1.25:1 to 10:1
Expansion Ratio	1:1.25 to 1:8
Attack Time	100 microseconds to 10 seconds
Release Time	100 microseconds to 10 seconds

Performance Data

Frequency Response	12 Hz to 20 kHz ± 1.5 dB, dynamics block out, EQ in (all levels set to 0), noise reduction out, de-ess out, delay out.
Mic input equivalent input noise	-127 dBm, 20 kHz NBW 150-ohm source
Distortion (THD)	<0.01% @ 1 kHz, 1V RMS
Dynamic range	>104 dB. This represents the difference between the largest and smallest signals that will pass through the 602. Measured using 8192 point FFT with Blackman-Harris windowing function.
Sample rate	48 kHz and 44.1 kHz
Converter types	Delta-Sigma
Conversion method	18-bit linear

MIDI

Connectors	In, Out/Through
Recognized/Transmitted	Program change, control change, SYSEX, continuous controllers
Memory	128 read-only presets, 128 read-write presets, memory protection, 3 front-panel lockout modes

Physical

Size (hwd)	1.75 x 19 x 7 inches, 4.44 x 48.26 x 17.78 centimeters
Weight	7.6 lbs (3.5kg) net

Electrical

Power requirements	117V ac nominal, 105 to 125V ac 50 to 60 Hz, 20 watts 230V ac nominal, 205 to 253V ac 50 Hz, 20 watts
--------------------	--

© 1995 Symetrix, Inc. Specifications subject to change without notice.

Architects and Engineers Specifications

The integrated signal processor (ISP) shall be an analog and digital I/O device accepting stereo or mono signals, applying frequency response equalization, delay-based effects and dynamics processing to those signals, and delivering the processed input signals to the outputs. All signal processing (equalization, delay, dynamics) shall take place in the digital domain. The ISP shall occupy one rack space (1U).

The equalizer block shall take the form of a user and MIDI programmable parametric equalizer capable of operating at three inflection points simultaneously. All three bands of the equalizer shall be capable of operating over the following frequency ranges and bandwidths: 31 to 21.11 kHz with a bandwidth of .05 to 3 octaves, with a boost/cut range of +15 dB to off.

The delay block shall provide two delays capable of up to 330 milliseconds of delay. The delays shall be user and MIDI programmable. The feedback path for delay recirculation shall be cross-coupled between the two delays and the delay time shall be capable of accepting modulation either from an internal random number generator or from an internal sine- or triangle-wave source.

The dynamics block shall provide the following functionality: De-ess, Dynamic noise filter, Compressor, AGC/Leveler and Downward Expander. Within the dynamics block all sections shall be user and MIDI programmable.

The output block shall provide level and panning for the output signal. Both functions shall be user or MIDI programmable. The level control shall operate in the digital domain over a ± 18 dB range.

The panpot shall also operate in the digital domain with a sine-cosine characteristic law.

The MIDI implementation, via MIDI Sysex, Control Change, and Program Change, shall provide access to all major operating parameters of the ISP and real-time editing capabilities shall be provided to allow real-time parameter change during operation.

The ISP shall be capable of accepting and delivering stereo digital input signals at either a 44.1 kHz or 48.0 kHz sample rate. The ISP shall be capable of converting analog signals to digital form using either the 44.1 kHz or 48.0 kHz sample rates.

The ISP shall be capable of accepting and delivering stereo digital signals conforming to the AES/EBU standard or to the S/PDIF standard. Four such digital connections shall be provided. The AES/EBU connections shall utilize 3-pin XLR connectors. The S/PDIF connections shall utilize RCA connectors.

The analog inputs shall be active balanced bridging designs. The line inputs shall be terminated in 3-pin XLR female connectors. All analog input circuitry shall incorporate RFI filters. The analog outputs shall be active balanced designs having equal source impedances and terminated with 3-pin XLR male connectors. All XLR connectors used for analog input/output shall conform to the AES/IEC polarity standard.

The ISP shall be capable of operating by means of its own built-in power supply connected to 117V nominal ac (105 to 130V) 50/60 Hz or 230V nominal ac, (207 to 253V, 50 Hz).

The unit shall be either a Symetrix Incorporated Model 601 or 602.

602

Symetrix

www.SteamPoweredRadio.Com

Symetrix Inc. • 14926 35th Ave. W. • Lynnwood, WA 98037 • USA • Tel: (206) 787-3222 • FAX: (206) 787-3211 • e-mail: 102102.1126@compuserve.com



THE SYMETRIX 572 SPL COMPUTER is an automatic level controller that maximizes intelligibility by changing gain in proportion to environmental noise level changes; in essence, controlling the volume of the background/paging system by measuring the volume of the ambient noise and then adjusting the system gain accordingly. Unique to the 572 is its ability to utilize the sound system's loudspeakers as noise measurement transducers, in place of the usual microphones.

The 572 switches the speaker line from the amplifier's output to its own sensing input. In less than one second it reads the ambient noise level and switches the speaker line back to the amplifier. Special impedance matching, frequency shaping, and level shifting circuits allow the 572 to acquire precise relative noise measurements from virtually any speaker line, with any number of speakers of any impedance, transformer coupled or direct coupled, 25V or 70V.

The operating characteristics of the SPL computer are controlled by a powerful microprocessor, running under Symetrix proprietary software. This reduces the 572's calibration time and allows the installer to optimize performance for any situation. No test gear is needed because the 572 obtains and stores the information it needs during calibration.

The 572 has separate inputs for paging and music as well as a direct paging microphone input. Both the speakers and the amplifiers connect directly to the 572. A front panel page over music function enables up to 14 dB of music attenuation during announcements. There are multiple option switches for telling the 572 how to treat the page/music signal as well as how to react to changes in the acoustic environment. The LED meter on the front not only indicates gain change but also aids in set-up and calibration and identifies errors.

You show the 572 the parameters of the acoustic environment during calibration and then set the way you want the unit to respond to changes. The 572 then takes the information it has stored in memory and makes smooth, appropriate changes to keep the levels exactly where you want them. In order for the speakers to act as loudspeakers and sensors, there must be times when no audio is passing through the speakers to allow the sample of the ambient noise to

be taken. This 572 takes advantage of silent periods in the paging or music to take a sample, or it forces a sample based on the front panel setting at timed intervals. The 572 will unobtrusively fade out the music, take a sample, and then fade the music back in, all in a matter of seconds. The 572 will not, however, interrupt any signal that appears at the page input, thus keeping the unit from forcing a sense period during a page.

From malls to restaurants to factories, the Symetrix 572 gives you effective, reliable, system level control without an operator or the normal additional costs.

571 vs. 572...

Which one is right for your application?

Both of our SPL Computers perform similar functions but are quite different in application and features.

The 571 uses one or more microphones to sense the ambient, therefore, there is no need to interrupt the audio signal to make changes. This is necessary for applications that require constant paging signals that need to be raised or lowered over short sections of time. The cost effective 572 uses the speaker system itself to sense changes, thus saving the installer/customer from the price of external sensing microphones and cabling, but it must have periodic silence in the audio for the speaker to perform as a sensor.

Features

- Uses speakers as noise sensing "microphones"
- Separate Page and Music inputs
- Works with direct coupled and distributed systems
- Fast, simple calibration
- Economical

Applications

FACTORIES

MALLS

AIRPORTS

RESTAURANTS

CASINOS

SCHOOLS

MUSEUM EXHIBITS

STADIUMS

572

572 SPL Computer

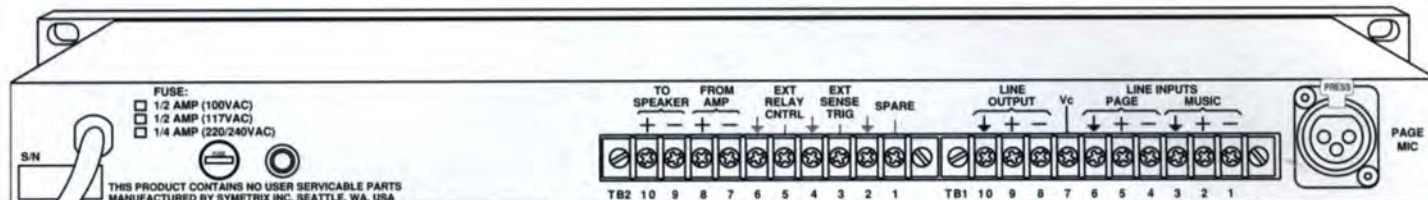

Specifications

Software	Copyright Symetrix, Inc. 1989	Output	Balanced, transformerless
Control Range	Variable, up to 40 dB (-20 dB to +20 dB)	Output Impedance	200-ohms balanced, 100-ohms unbalanced Minimum load: 600-ohms balanced Nominal level 0 dBm Maximum level +24 dBm (into 600-ohms)
Noise-to-Gain Ratio	Variable, 2:1 to 1:2	Gain (VCA at unity)	Balanced input to unbalanced output = 0 dB Unbalanced input to balanced output = 6 dB
Sample Interval	Forced: Variable, 1 min. to 26 min Auto: Silence periods (< -30 dBm) > 800 ms Page-Over Music: Variable, 0 to 15 dB	Vc Scale	156 mV/ dB
Frequency Response	20 Hz to 20 kHz +1 dB, -0 dB	Physical Size	1.75"H x 19"W x 7.5"D inches overall (4.45H x 48.3W x 19.5 cm overall) 1.75"H x 19"W x 6.5" inches depth behind panel (4.45H x 48.3W x 16.5 cm depth behind panel)
THD+N	<0.05% THD, unity gain, 1kHz music into balanced output	Weight	8lbs (3.6 kgs)
Signal-to-Noise Ratio	>70 dB, ref: 0 dBu, unity gain (30 kHz noise bandwidth)	Electrical Power Requirements	117 V ac, 60 Hz, .1amp (approx. 12 watts)
Input	All balanced, transformerless	©1995 Symetrix, Inc. Specifications subject to change without notice.	
Inputs	Impedance >1800 ohms		
Paging mic (For microphone level paging signals)	Nominal level -80 dBu to -40 dBu Maximum level -30 dBu CMRR >60 dB		
Paging (For line level paging signals)	Impedance >40 kilohms Nominal level 0 dBu, Maximum level +18 dBu CMRR >40 dB		
Music (For line level music signals)	Impedance >40 kilohms Nominal level -10 dBu, Maximum level +18 dBu CMRR >40 dB		

Architects and Engineers Specifications

The ambient sensing automatic level controlling device shall regulate the operating level of a sound system in proportion to changing noise levels in the sound system's operating area. The device shall be capable of adjusting gain control over 40 dB overall (max) range, and shall be governed by a microprocessor which shall be controlled by embedded software. The device shall vary its gain based upon measurements of the sound pressure level of ambient noise in the environment. These sound level measurements shall be made by the level controlling device through the loudspeakers otherwise used for the system's output. To facilitate the use of the system's loudspeakers as noise measuring "microphones," the device shall provide relay switching of the speaker line circuit so as to disconnect the speakers from the amplifier output and connect the speakers to its own sensing input. The device shall provide inputs for paging signals at microphone level (nominal -40 dBv) or line level (nominal 0 dBv), and for music signals at line level (nominal 0 dBv). The device shall have a Ratio control to vary the ambient noise-to-gain ratio continuously from 2:1 to 1:2, and a front panel switchable hard-wired bypass. Calibration of the

automatic level controlling device shall be semi-automatic, and shall require switching the device to CAL Mode, and adjusting the minimum desired operating level and the maximum desired operating level. Calibration settings shall be continuously maintained in non-volatile memory without the need for battery pack up power.

In addition to the various functions and general specifications mentioned above, the ambient sensing automatic level controlling device shall meet or exceed the following overall performance criteria: frequency response ± 1 dB 20 Hz to 20 kHz, total harmonic distortion less than .05% at any attenuation from -40 dB to 0 dB (2 kHz), maximum paging microphone input level -30 dBv, maximum line input level +18 dBu, maximum output level +24 dBm into 600-ohms (balanced). Minimum impedance at the microphone inputs shall be 1800 ohms, minimum impedance at the line inputs shall be 10 kilohms. The device shall be housed in an all steel chassis designed to be mounted in a 1U (1.75") space in a standard 19" rack. The ambient sensing automatic level controlling device shall be the Symetrix model 572 SPL Computer.

572



THE SYMETRIX 571 SPL COMPUTER is an automatic level controller that maximizes intelligibility by changing gain in proportion to environmental noise level changes. In essence, controlling the volume of the sound system by measuring the volume of the ambient noise and then adjusting the system gain accordingly. The operating characteristics of the SPL computer are controlled by a powerful microprocessor, running under Symetrix proprietary software. This reduces the 571's calibration time and allows the installer to optimize performance for any situation. No test gear is needed because the 571 obtains and stores the information it needs during calibration.

The 571 has separate inputs for paging and music as well as dual microphone inputs for the sensing microphones and a direct paging microphone input. A front panel page over music function enables up to 14 dB of music attenuation during announcements. There are multiple option switches for telling the 571 how to treat the page/music signal as well as how to react to changes in the acoustic environment. The LED meter on the front not only indicates gain change but also aids in set-up and calibration.

More than just a volume control, the 571 has an "averaging time" control for the mic sensing and a ratio control for adjusting the reaction of the 571 to the changes in the ambient noise. The real intelligence of the 571 lies in its ability to ignore the changes of signals passed through it and therefore won't allow runaway gain changes as the system tries to chase itself. You show the 571 the parameters of the acoustic environment during calibration and then set the way you want the unit to respond to changes. The 571 then takes the information it has stored in memory and makes smooth, appropriate changes to keep the levels exactly where you want them.

From racetracks to ballrooms to subway stations, the Symetrix 571 gives you effective, reliable, system level control that reacts to real world changes, not timer set programs.

571 vs. 572

Which one is right for your application?

Both of our SPL Computers perform similar functions but are quite different in application and features.

The 571 uses one or more microphones to sense the ambient and therefore doesn't need to interrupt the audio signal to be able to make changes. This is necessary for applications that require constant paging signals that need to be raised or lowered over short sections of time. The cost effective 572 uses the speaker system itself to sense changes, thus saving the installer/customer from the price of external sensing microphones and cabling, but it must have periodic silence in the audio for the speaker to perform as a sensor.

Features

- Constant or averaged time sensing (1.2 secs. to 5 min.)
- No runaway gain, feedback
- 40 dB control range
- Ignores level changes in the audio signal passing through the SPL computer
- Allows for more than one microphone to "average" a room's ambient signal

Applications

FACTORIES

AIRPORTS

RESTAURANTS

CASINOS

SCHOOLS

MUSEUM EXHIBITS

STADIUMS



Symetrix

571 SPL Computer

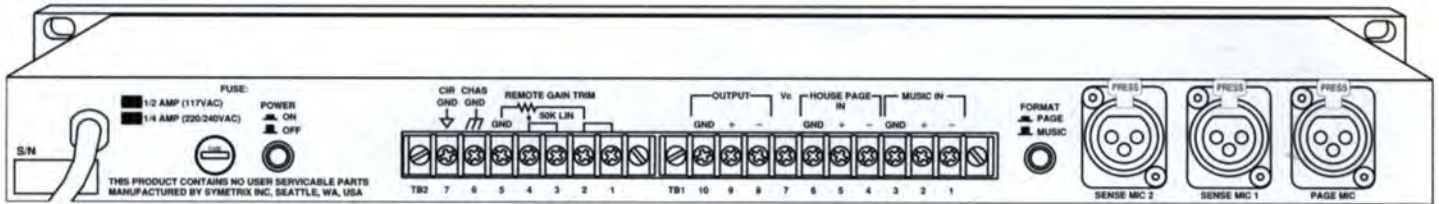

Specifications

General Performance Data

Maximum Control Range	40 dB
Ambient Noise-to-Gain Ratio	Variable, 2:1 to 1:2
Averaging Time	1.2 sec. to 5 min.
Page-Over Music (ducking)	Variable, 0 to 14 dB
Frequency Response	20 Hz to 20 kHz + 1 dB, -0 dB
THD+N	<0.05%, unity gain, 2 kHz, music in to line out
Noise	Less than -85 dBm, unity gain (30 kHz noise bandwidth)

Input/Output

Maximum Output Level	+24 dBm (600 ohms balanced)
Maximum Input Level	-30 dBu (mic inputs) +18 dBu (line inputs)
Input Impedance	Mic: electronically balanced bridging 200 ohms, nominal (not phantom powered) Line: electronically balanced bridging, 20 kilohms nominal
Inputs	2 sensing mic (-40 dBu nominal) CMRR = >60 dB at 1 kHz 1 paging mic (-40 dBu nominal) CMRR = >60 dB at 1 kHz 1 line (0 dBu nominal) CMRR = <40 dB at 1 kHz 1 music (-10 dBu nominal) CMRR = <40 dB at 1 kHz
Output	Transformerless balanced
Output Impedance	100 ohms

©1995 Symmetrix, Inc. Specifications subject to change without notice

Architects and Engineers Specifications

The ambient sensing automatic level controlling device shall regulate the operating level of a sound system in proportion to changing noise levels in the sound system's operating area. The device shall be capable of providing gain control over up to 40 dB overall range, and shall be governed by a microprocessor which shall be controlled by embedded software. The device shall vary its gain based upon measurements of the sound pressure level of ambient noise in the environment. Inputs shall be provided for up to two sensing microphones. The device shall be capable of making 215 sound pressure level measurements per second, and shall have a continuously variable Averaging Time control to cause the device to maintain a running average of those measurements for a minimum of 1.2 seconds to a maximum of 5 minutes, before using that average to compute gain adjustments. The device shall provide inputs for paging signals at microphone level (nominal -40 dBu) or line level (nominal 0 dBu), and for music signals at line level (nominal -10 dBu). Automatic regulation shall be selectable to apply to paging signals only (Page mode), or to apply primarily to music signals (Music mode). In Page mode the device shall adjust paging levels continuously with respect to ambient noise sound pressure levels. In Music mode the device shall adjust background music levels continuously with respect to both ambient noise levels and paging activity; in Music mode, paging signals shall cause the device to attenuate music signals as determined by its Page-Over Music control, which shall be continu-

ously variable from 0 to 14 dB (ducking). The device shall have a Ratio control to vary the ambient noise-to-gain ratio continuously from 2:1 to 1:2. An Output Gain Trim control shall be provided to allow overall gain to be adjusted over a 20 dB range. The Output Gain Trim control shall be remote controllable at a distance of up to 400 feet by the connection of a 50 kilohm variable resistor. Calibration of the automatic level controlling device shall be semi-automatic, and shall require switching the device to CAL Mode, and adjusting the minimum desired operating level, and the maximum desired operating level. Calibration settings shall be continuously maintained in non-volatile memory without the need for battery pack up power.

In addition to the various functions and general specifications mentioned above, the ambient sensing automatic level controlling device shall meet or exceed the following overall performance criteria: frequency response ± 1 dB 20 Hz to 20 kHz, total harmonic distortion less than .05% at any attenuation from -40 dB to 0 dB (2 kHz), maximum paging microphone input level -30 dBu, maximum line input level +18 dBu, minimum sensing microphone input level -80 dBu, maximum output level +24 dBm into 600 ohms (balanced). Minimum impedance at the microphone inputs shall be 1800 ohms, minimum impedance at the line inputs shall be 10 kilohms. The device shall be housed in an all steel chassis designed to be mounted in a 1U (1.75") space in a standard 19" rack. The ambient sensing automatic level controlling device shall be the Symmetrix model 571 SPL Computer.

571

564E Quad Expander/Gate



SONICALLY SUPERIOR, easy-to-use, and built to survive the rigors of the road, the 564E Quad Expander/Gate provides four channels of powerful expansion and gating functions with frequency conscious detection in one single rack space. We didn't cut any corners when we designed this unit. Inside and out, it's built for the most demanding audio applications.

Let's get right to the point. How fast is it? Very. It goes from 50 dB of attenuation to full open in 50 microseconds. A little math will show you that a 20 kHz attack transient will pass through unaffected. Totally free from the "dulling" effect of other, slower designs, the 564E insures that your all-important drum sounds are clear, crisp, and completely free of any audible distortion.

Easy-to-use and flexible. These may appear to be contradictory, yet the 564E delivers the goods. Our proprietary program-interactive release circuit delivers smooth, natural-sounding decay envelopes automatically. We've simplified the Gate Range and Expander Ratio controls by putting them all on one knob so you can quickly dial in the right amount of attenuation.

Unlike competing units that use "soft-gate" for signals with long attacks and decays, the 564E uses true downward expanders. Noise gates work like on/off switches which can cut off the beginnings or endings of signals. A "true" downward expander works like a fader that can follow signals up and down giving a smoother reaction. This allows you to achieve the same noise reducing characteristics as a noise gate without the unwanted artifact.

If a noise gate is desired for fast transient signals the user simply turns the knob until the correct amount of gate range is dialed in. As for flexibility, the Key Filters prevent unwanted sounds from triggering the gate action. For instance, use the Lowpass filter to prevent the high-hat from opening the snare gate. You can set this easily by ear using the Key Listen mode. Symetrix uses a combination of Hipass and Lowpass filters for the frequency divisions instead of a single frequency and bandwidth control. This allows the user to set up a window of accepted frequencies instead of just one small frequency band.

This combination of frequency detection and downward expansion allows the Symetrix 564E to be used on cymbals, voices, woodwinds, and other softer, low transient signals. Of course you still have the ability to perform gating for higher transient signals like a snare drum. There are also sidechain send and return points for even more extensive audio tricks.

All this is packed into a rugged, 1U package. Features like electronically balanced XLR inputs and outputs, toroidal power supply transformer, and 12 gauge steel chassis guarantee that the 564E will stand up to years of road abuse; delivering top dollar performance at a reasonable price.

Whether it's separating live drum mics, automatically closing unused channels in a mixdown, or controlling noise on mics in a boardroom table discussion, the Symetrix 564E was made for the job.

Features

- Four channels of expander/gate in one rack space
- Sidechain filters for "frequency conscious" gating
- Key Listen function for precise filter settings
- Attack and release time controls
- Transparent, studio quality audio

Applications

STUDIO RECORDING

CONCERT SOUND REINFORCEMENT

AUTOMATIC MIC MIXING

AUDIO FOR VIDEO/FILM POST PRODUCTION

TELECONFERENCING SYSTEMS

If You Didn't Get This From My Site,
Then It Was Stolen From...

www.SteamPoweredRadio.Com

564E Quad Expander/Gate

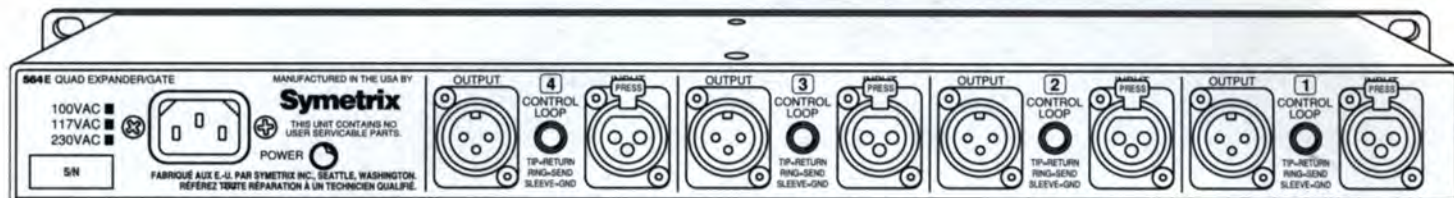

Specifications

Input/Output

Inputs	XLR-female, 20 kilohms line-level balanced bridging.
Maximum input level	+18 dBu
CMRR @ 1kHz	>40 dB.
Outputs	200-ohm source impedance, floating balanced, XLR-male
Maximum output level	600-ohm load +24 dBm balanced +18 dBm unbalanced

Sidechain / Control Loop (Key Input)

Connector	TRS female, tip=return, ring=send.
Input Impedance	30 kilohms, unbalanced
Max input level	+18 dBu maximum
Output Impedance	300 ohms, unbalanced
Control voltage rejection	80 dB, measured at output with 100 Hz square wave applied to Control Loop input

Lowpass/Hipass Filters

Type	12 dB/octave Butterworth
Frequency Response, fully open	30 Hz to 30 kHz
Hipass Filter Range	30 Hz to 4 kHz
Lowpass Filter Range	150 Hz to 30 kHz

Gate

Maximum Attack	50 dB/50 μ s
Minimum Attack	50 dB/200 μ s
Maximum Release	50 dB/2 ms
Minimum Release	50 dB/3 sec
Range	0-60 dB

Downward Expander

Characteristic	Soft-knee
Attack (fast)	50 dB/2 ms
Attack (slow)	50 dB/2 ms
Release (fast)	50 dB/0.7 sec
Release (slow)	50 dB/8.5 sec
Ratio	1:1 to 1:3
Max Attenuation	Greater than 50 dB

Performance Data

Frequency Response	20 Hz to 20 kHz, +0, -1 dB
Distortion (THD+N) @ 1kHz	<0.03% @ 0 dB GR <0.05% @ 10 dB GR
Crosstalk	>90 dB @ 20 kHz
Dynamic Range	110 dB
Signal to Noise Ratio	92 dB @ 0 dBu in, 0 dBu out

Physical

Size, H x W x D	Front Panel: 1.75 x 19 in., 4.5 x 48.3cm Chassis: 1.7 x 17.4 x 9.6 in, 4.3 x 45 x 24 cm
Weight	11 lbs (5 kg) shipping

Electrical

Power requirements	117V ac nominal, 105 to 125V ac 50 to 60 Hz, 16 watts 230V ac nominal, 205 to 253V ac 50 Hz, 16 watts
--------------------	--

©1995 Symetrix, Inc. Specifications subject to change without notice

Architects and Engineers Specifications

The Quad Expander/Gate shall provide four independent channels of dynamic range expansion for wideband, wide range audio signals. The Expander/Gate shall occupy one rack space (1U).

Gate range and Expander ratio shall be continuously adjustable via a single front panel control. The threshold shall be adjustable from -40 dBu to +20 dBu. Expander mode shall offer program dependent attack time within two ranges selectable from a front panel pushbutton. Gate mode shall have two, fixed, selectable attack times. Release time shall be continuously variable from the front panel.

There shall be separate, tunable, high pass and low pass filters in series within the control loop. The cutoff frequencies shall be individually adjustable via separate front panel controls. A Key Listen mode shall be provided to route the side chain signal to the channel audio output for listening during setup.

Each channel shall have a six segment LED meter that shall indicate gain reduction amount. The meter shall have a range of 40 dB.

Pre-filter control loop access will be available via a 1/4" TRS female jack. This shall be wired Tip=Return, Ring=Send, Sleeve=Ground.

The inputs shall be active balanced bridging designs terminated with 3-pin XLR (AES/IEC standard wiring). The input circuitry shall incorporate

RFI filters. The outputs shall be active balanced designs having equal source impedances and terminated with 3-pin XLR (AES/IEC standard wiring).

The inputs shall accommodate +18 dBu signals without distortion, and the balanced outputs shall be capable of delivering +24 dBm into a 600-ohm load.

Overall frequency response (+0, -1 dB) shall be 20 Hz to 20 kHz. THD+N shall no be greater than 0.03%, 0 dB g/r, 1 kHz into a 600-ohm load. Dynamic range shall be 110 dB.

Rack-mounting hardware shall be integral to chassis top, sides and face. Chassis top and sides shall be formed from 12 gauge CRS. All XLR connectors shall be mounted on, and supported by, chassis panels. The unit shall occupy one rack space (1U).

The unit shall have a built-in power supply with a toroidal power transformer, and operate from 117V nominal ac (105 to 130V) 50/60 Hz or 230V nominal, 207 to 253V ac, 50 Hz.

The unit shall be a Symetrix Incorporated model 564E Quad Expander/Gate.

564E

Symetrix

Symetrix Inc. • 14926 35th Ave. W. • Lynnwood, WA 98037 • USA • Tel: (206) 787-3222 • FAX: (206) 787-3211 • e-mail: 102102.1126@compuserve.com

www.SteamPoweredRadio.Com

528E Voice Processor



THE 528E is a complete, self-contained voice processor that performs six separate functions: microphone pre-amplification, de-essing (sibilance removal), compression/limiting, downward expansion, parametric EQ, and voice symmetry alignment. All six processors may be used simultaneously. Although we call the 528E a "Voice Processor", it is perfectly suitable for any signal, vocal or not.

Each function features a full complement of controls in an easy-to-use layout. Separate LED meters monitor mic gain and dynamics gain reduction functions thus facilitating quick and accurate adjustment of controls. As a dedicated single-channel voice processor, the 528E delivers the same processing power found in an entire recording studio signal chain. With the 528E you get all the control you need, without the cost or complication of separate units.

The 528E works with any professional microphone. The mic preamp's gain is variable up to 60 dB, and 48 volt phantom power is provided for condenser mics. A switchable 15 dB pad reduces gain in front of the mic pre-amp to prevent distortion in super close micing situations. A front panel switch selects between microphone or line input. Both inputs are transformerless and are equipped with filters to prevent radio frequency interference (RFI).

The de-esser senses and regulates selectable high frequencies to reduce or eliminate annoying sibilance and "lip smacking". De-esser controls are Frequency and Range.

Symetrix' program controlled Integrated Dynamics Processing (IDP) techniques combine the best attributes of compressor/limiters and downward expanders. The compressor/limiter maintains uniform levels while the downward expander eliminates "pumping", "breathing", and noise build up. Because it's program controlled, the 528E's dynamic range processor responds quickly to transients, and gently to smaller level changes. Controls provided are Expand Threshold, Compress Threshold, and Compression Ratio.

The three band parametric EQ performs both creative and corrective operations, with bandwidth variable from .3 octave to 4 octaves, 15 dB boost/cut, and overlapping frequency ranges.

A unique "leap frog" topology minimizes the number of amplifiers in the signal path while ensuring that each frequency band interacts with its neighbor in a desirable and musical fashion. Use the 528E's parametric to enhance voices and/or eliminate resonances and interference. EQ controls are Cut/Boost, Bandwidth, and Frequency for each of three bands.

The voice symmetry switch corrects for excessive positive or negative signal peaks of the human voice. A simple in/out switch controls Voice Symmetry.

Revered as the choice for broadcast voices and known as the "one channel console" by recording studios, the 528E easily steps into the track of it's predecessor, the Symetrix 528 Voice Processor.

Features

- Works with any microphone (or line input)
- Enhances vocal intelligibility
- Increases perceived loudness and "presence"
- Great for voices as well as instruments and effects
- Reduces off-mic noise
- Reliable, proven design

Applications

BROADCAST ANNOUNCE MICS

VOICE-OVERS AND MUSIC RECORDING

HIGH LEVEL SOUND REINFORCEMENT

PUBLIC ADDRESS/PAGING SYSTEMS

528E

528E Voice Processor

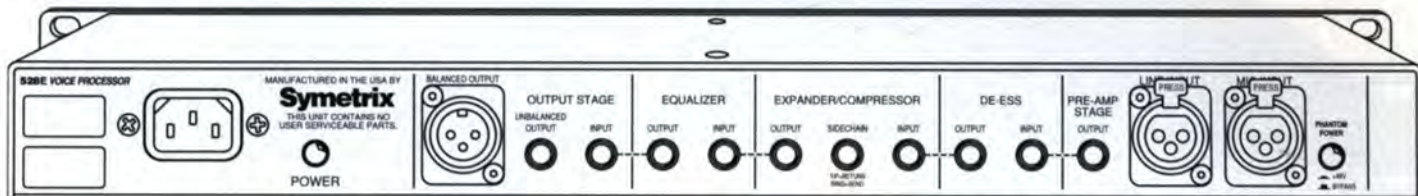

Specifications

Inputs

Controls and Switches	Mic Gain, Phantom Power, Mic/Line
Mic and Line input connectors	XLR female (2)
Clip LED	Fires at +17 dBu output level from mic preamp or line input amplifier
Microphone input type	Balanced transformerless, low impedance
Phantom Power (DIN 45 596)	+48V, nominal
Microphone Pre-amp Gain	22 to 60 dB (pad out), 7 to 45 dB (pad in)
Microphone input maximum input level	-3 dBu (pad out)
Equivalent Input Noise (EIN)	-126 dBV. (150-ohm source, 20 Hz to 20 kHz)
THD+N (preamp only)	0.05% (2 kHz, 50 dB gain, +17 dBu output)
Mic Pre-amp CMRR	> 60 dB (40 dB gain, 20 Hz to 20 kHz)
Line input type and impedance	10 kilohm transformerless balanced bridging
Line input maximum input level	+24 dBu
Line input nominal input level	+4 dBu
Line input CMRR	> 50 dB (0 dBu, 20 Hz to 20 kHz)

Parametric Equalizer

Type	Three-band parametric equalizer
Bands	Low: 16 to 500 Hz, Mid: 160 to 6300 Hz High: 680 Hz to 22 kHz
Peak/Dip Bandwidth	.3 to 4 octaves, measured at maximum boost
Maximum boost/cut	±15 dB

Metering

Type	Multi-segment LED bargraph
Output Level	-20 to +3 VU (0 VU = +4 dBu), VU calibrated, peak responding
Gain Reduction	Separate displays for: de-esser, downward expander, compressor. 0 to 20 dB per display

Overall Performance Data

Frequency Response	20 Hz to 20 kHz +0, -0.5 dB, EQ out compressor out, downward expander out, de-esser out
THD	.05%, 20 Hz to 20 kHz, +4 dBm output
Noise Floor	better than -89 dBu, 20-22 kHz.

Dynamic Range Processor

Type	Interactive comp/limiter-downward expander
Comp/limiter ratio	1:1 to 10:1
Downward Expansion ratio (max)	1:1.8
De-esser Type	Program controlled high-cut filter, 12 dB/octave
Frequency Range	800 Hz to 8000 Hz
Threshold	-30 to 0 dBu
Output Section Type	Balanced transformerless
Maximum output level	+24 dBm balanced, +18 dBm unbalanced
Connector	XLR male
Output Clip LED	Fires 3 dB below clipping
Output source impedance	200 ohms, balanced
Minimum load impedance	600-ohms balanced or unbalanced
Voice Symmetry switch	Improves modulation symmetry of speech signals
Output gain	±15 dB

Physical

Size (hwd)	1.75 x 19 x 7 in 4.44 x 48.26 x 17.78 cm
Weight	7.6 lbs (3.5kg) net 10 lbs (4.6kg) shipping

Electrical

Power requirements	117V ac nominal, 105 to 125V ac 50 to 60 Hz, 18 watts maximum 230V ac nominal, 205 to 253V ac 50 Hz, 18 watts maximum
--------------------	--

©1995 Symetrix, Inc. Specifications subject to change without notice

Architects and Engineers Specifications

The voice processor shall be capable of all signal processing functions commonly found on a mixing console input channel, including microphone signal preamplification, line input buffering, simultaneous de-essing, downward expansion, compression/limiting, and parametric equalization.

The unit shall have a low-noise, low distortion microphone preamplifier with variable gain (22 dB to 60 dB) and switchable (on/off) +48V phantom power. A 15 dB pad shall be provided to accommodate high-output microphone signals. A balanced-bridging line input suitable for +4 dBu input signals shall also be provided along with a switch to select either the microphone or line inputs.

The voice processor shall have an integral de-esser which shall offer up to 20 db of attenuation within a manually sweepable frequency range of 800 Hz to 8 kHz. There shall be front panel controls for range, frequency, and a bypass switch.

The dynamics processing section shall contain an interactive compressor/limiter and downward expander. There shall be front panel controls for compression ratio (1:1 to 10:1), compressor threshold (-50 dBm to +20 dBm), expander threshold (-30 dBm to 0 dBm), and a bypass switch.

There shall be a three-band parametric equalizer. Each band shall have ±15 dB maximum boost/cut, and continuously variable bandwidth (.3 octaves to 4 octaves). The equalizer bands shall have substantially overlapping frequency ranges, with a combined range of 16 Hz to 22 kHz. There shall be a front panel bypass switch.

The voice processor shall be equipped with the following LED displays: An eight-segment LED display shall be provided for monitoring the overall output level, six-segment displays for monitoring the de-esser, compres-

sor/limiter, and downward expander. All displays shall be independent. There shall also be a single LED clip indicator to indicate clipping within either of the input preamplifiers or buffers.

The microphone input shall be an active balanced bridging design terminated with 3-pin XLR-female connector (AES/IEC standard wiring). The microphone preamp shall be capable of an equivalent input noise specification of at least -126 dBu (150-ohm source, 60 dB gain, 20 Hz to 20 kHz). The line input shall be a balanced, transformerless design using a 3-pin XLR-female connector (AES/IEC standard wiring). All input circuitry shall incorporate RFI filters of the LC lowpass type.

The output shall be an active balanced design terminated with a 3-pin XLR-male connector (AES/IEC standard wiring). The output signal level shall be switchable to accommodate subsequent line or microphone inputs. The output section shall provide a switchable phase rotator for the purpose of improving the asymmetry of speech waveforms.

Access to the dynamics processing sidechain shall be provided via a 1/4 inch TRS jack. Access to the interstage connections between all processing sections (mic/line preamp, de-esser, compressor/limiter/downward expander, equalizer, output stage) shall be provided via half-normalized tip-ring-sleeve (TRS) jacks.

The voice processor shall be capable of operating by means of its own built-in power supply connected to 117V ac nominal (105 to 130V), 50/60 Hz or 230V ac nominal (207 to 253V), 50 Hz.

The unit shall be a Symetrix Incorporated model 528E Voice Processor.

528E

Symetrix

Symetrix Inc. • 14926 35th Ave. W. • Lynnwood, WA 98037 • USA • Tel: (206) 787-3222 • FAX: (206) 787-3211 • e-mail: 102102.1126@compuserve.com

www.SteamPoweredRadio.Com

501 Peak-RMS Compressor/Limiter



THE SYMETRIX 501 PEAK/RMS COMPRESSOR/LIMITER is a precision dynamic range controller intended for use in the most demanding professional audio applications. The 501 is two dynamics controllers in one unit. Separately controlled, simultaneous RMS detection and peak limiting is provided so that the limiter can be set to prevent spikes and allow the compressor to control the signals without applying more than the desired amount of gain reduction. The 501 performs both duties with unsurpassed distortion and noise specifications. A full complement of controls gives the operator the ability to perfectly tailor dynamic response. This isn't a one slider device, you are in control.

Standard engineering practice often calls for the use of low ratio compression, as a creative device, to achieve dynamic characteristics that are more pleasing to the ear. Since the 501's compressor is RMS responding (like the human ear) it's easy to get a consistent, more listenable sound. The RMS compressor section is designed to provide both manual and automatic (program controlled) attack and release times. The wide range of the ratio and threshold controls make the 501 usable over a 50 dB range. RMS detection, high headroom input circuits and output drivers, give the 501 its well known sonic excellence.

However, an RMS compressor alone does not prevent clipping distortion or tape saturation. For this reason, standard practice also dictates the use of a peak limiter, as a protection device, to take control of transient peaks that would otherwise cause overload distortion. The peak limiter catches even the fastest transient spikes, with its exceedingly quick 2000 dB/msec attack time.

With both types of processing in the same package, the Model 501 provides both creative and protective dynamic range control. This is one reason why the 501 has become not only a first choice for vocal applications but is widely known as "the" compressor/limiter choice for bass players, allowing the low frequency notes to sound close and full, while protecting the player's amp from overloading during sharp slaps and pounding of the bass strings. With this type of performance and reliability the 501 has become the audio experts' tool of necessity.

Backed by eighteen years of designing audio processors, the Symetrix 501 can only be called "performance elegance" in the classic sense of audio quality and reliability.

Features

- RMS and interactive Peak control
- Manual or Automatic attack/release
- Balanced and Unbalanced connections
- Stereo linkable
- Sidechain access

Applications

"LEGENDARY" CHOICE FOR BASS PLAYERS

SOUND REINFORCEMENT

Protect amps and speakers from audio spikes

RECORDING

Compression for smooth vocals with simultaneous protection from the limiter

BROADCAST

Provides consistent program levels and protection against overshoot

501

501 Peak-RMS Compressor/Limiter

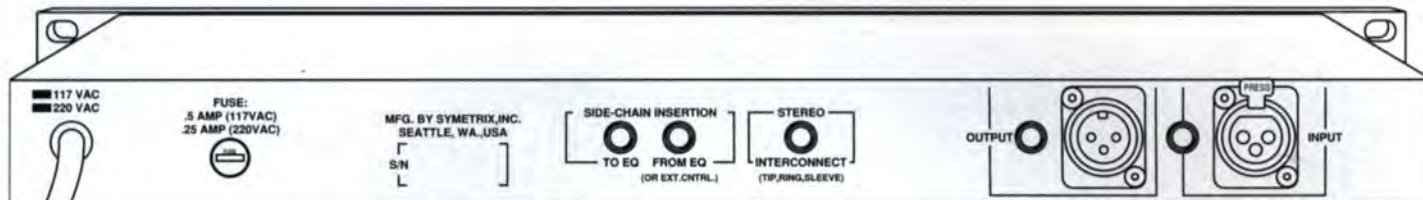

Specifications

Input/Output

Inputs	XLR-female, >20-kilohms line-level balanced bridging, >20-kilohms unbalanced bridging TRS-female paralleled with XLR connector
Outputs	200-ohm source impedance, balanced. XLR-male TS-female (unbalanced) transformer balanced optional 100-ohm source impedance
Maximum input level	+20 dBu, balanced
Maximum output level (onset of clipping/1% THD)	+26 dBm balanced (600 ohms) +20 dBm unbalanced (600 ohms)
Sidechain	100-ohm source impedance 7-kilohm input impedance
	Separate TS, unbalanced, send and receive jacks

Compressor

Type	RMS responding, soft-knee
Manual Attack time	variable: .25 to 12 dB/ms
Manual Release time	variable: 5 to 300 dB/sec
Auto-release time	program dependent
Threshold	-40 dBu to +10 dBu
Ratio	1.4:1 to ∞:1

Limiter

Attack time	2000 dB/ms (approximately 1/2 cycle at 50 kHz)
Release time	110 dB/sec
Threshold	-10 dBu to +20 dBu
Ratio	∞:1

Performance Data

Frequency Response	20 Hz to 20 kHz +0, -1 dB
THD+N	.025 %, +0 dBm in, +0 dBm out, 10 dB gain reduction, 1 kHz, 30 kHz low-pass filter <0.09 %, +0 dBm in, +0 dBm out, 10 dB gain reduction, 20 kHz (distortion products primarily 2nd harmonic)
Equivalent Input Noise (EIN)	better than -85.5 dBu, 600-ohm source impedance, unity gain better than -95.5 dBu, 600-ohm source impedance, 20 dB gain reduction

Physical

Connectors	input: XLR-3F, 1/4" TRS output: XLR-3M, 1/4" TS sidechain: 1/4" TS (two)
Size (hwd)	1.75 x 19 x 5 in 4.44 x 48.3 x 12.7 cm
Weight	7 lbs (15.4kg) shipping

Electrical

Power requirements	117V ac nominal, 120V ac 60 Hz, 12.5 Watts maximum 230V ac nominal, 240V ac 50 Hz, 12.5 Watts maximum
--------------------	---

©1995 Symetrix, Inc. Specifications subject to change without notice.

Architects and Engineers Specifications

The compressor/limiter shall be a single channel unit that reduces the dynamic range of wideband, wide range audio signals. It shall have separate compressor and peak limiter sections and occupy a single rack space (1U).

The unit shall have a RMS responding compressor section with separate controls for ratio, threshold, attack, and release. A front panel switch shall be provided to engage the auto release time mode. The ratio shall be adjustable from 1.4:1 to infinity: 1. The peak limiter shall have a fixed infinity: 1. ratio, fixed attack rate of 2000 dB/ms, and adjustable threshold (-10 dBm to +20 dBm).

The inputs shall be active balanced bridging designs terminated with 3-pin XLR (AES/IEC standard wiring), and 1/4" TRS. The input circuitry shall incorporate RFI filters. The output shall be an active balanced design, terminated with 3-pin XLR (balanced output, AES/IEC standard wiring), and a 1/4" TS jack (unbalanced output). The active-balanced output shall be capable of delivering +26 dBm, balanced, into a 600-ohm load. A transformer-coupled output shall be available as an option. There shall be separate 1/4" TS female connectors provided for the sidechain send and return.

The unit shall be capable of being linked with another like unit for stereo operation. In this mode, the overall gain reduction of the two channels shall be based upon the mono-sum of the two input signals and each unit shall receive identical gain-reduction control signals. The stereo-link function shall be controllable via a front-panel switch.

Overall frequency response shall be 20 Hz to 20 kHz (0 dB, -1 dB). THD shall not exceed .025% with 10 dB gain reduction, 600-ohm load, 1 kHz tone at 0 dBm. The equivalent input noise (EIN) shall be -85.5 dBu or better at unity gain with a 600-ohm source over a 20 Hz to 22 kHz noise bandwidth.

The AGC shall be capable of operating by means of its own built-in power supply connected to 117V nominal ac (105 to 130V) 50/60 Hz (230V nominal, 207 to 253V ac, 50 Hz where applicable).

The unit shall be a Symetrix Incorporated model 501 Peak RMS Compressor/Limiter.

501

Symetrix

Symetrix Inc. • 14926 35th Ave. W. • Lynnwood, WA 98037 • USA • Tel: (206) 787-3222 • FAX: (206) 787-3211 • e-mail: 102102.1126@compuserve.com

www.SteamPoweredRadio.Com



EVER WONDER what sets the really successful engineers and producers apart from the Joe Average ones? Well, from our conversations with Grammy Award winners there appear to be lots of things. In our quest for new product ideas, these experts provided us with some valuable clues. No matter what brand console or recorder they use there's a sacred, unwritten rule: pay meticulous attention to levels and cut tracks hot!

The Symetrix 488 DYNA-Squeeze™ is an eight channel compressor/interface for use with digital multitrack recorders/workstations in recording and production studios. Interfaced between mixing console and recorder, the 488 gently squeezes your tracks toward the upper end of the recorder's dynamic range, giving digital recordings the feel of analog while preserving the clarity of digital. The results are impressive, the tracks are hot!

Tracks processed by DYNA-Squeeze have "presence" and increased articulation which is lacking in unprocessed tracks. Vocals punch. Acoustic instruments and drums come forward. Reverb "tails", cymbal decays. And other subtle nuances are more up front. When it's time to mix, DYNA-Squeeze'd tracks let engineers and producers sit back and concentrate on the creative aspects of the mix instead of riding gain on tracks that were cut at the wrong levels. Ask anyone who knows - better basic tracks make for a better final mix. With DYNA-Squeeze tracking goes faster and sound quality gets better. It's that simple.

For all their strengths, digital recording devices have several distinct weaknesses: at high levels, they're very unforgiving. Hit them with just a little too much input level and WHAMO! Digital clipping and unusable audio. At low levels they lack the resolution to accurately reproduce the signals at their input. Subjectively, most engineers and producers hear this as "graininess". So what do people do? They record at very conservative, very low levels to avoid clipping; therefore accepting reduced signal to noise ratio, and an increase in low level distortion! Engineers who painstakingly ride gain down to avoid digital clipping rob themselves of valuable creative time while they're lucky to get 12 bits out of a well designed 16 bit recording system. Is this trade-off really necessary? Not at all. Not with DYNA-Squeeze!

The 488 is easy to use. Set up is embarrassingly simple. Just use standard patch cords to connect

DYNA-Squeeze between your console's bus outputs and your recorder's inputs. Once connected, guess what? You don't have to run the faders on your console at ridiculously low levels any more to avoid overloading your recorder! Most analog consoles put out much more level than digital (or analog) multi-tracks will accept. Most likely your console outputs go to +24 level. The unbalanced input of the ADAT, for example, reaches full scale (digital clip) at +8 dBV! Enter DYNA-Squeeze. DYNA-Squeeze's rear panel +/-10 switch lets you come at DYNA-Squeeze full on (our input doesn't clip until +24!). Then we drop our output signal by just the right amount to perfectly interface to ADAT and DA-88. A single, wide range threshold control sets the amount of gain riding for all eight channels. Run your console levels up to where you're comfortable, adjust the DYNA-Squeeze threshold for the sound you like, and take off. That's all there is to it.

If you record to digital tape (ADAT, DA-88, 3324, etc.) or to a disk-based workstation (PROTOOLS, SPECTRAL, SADIE, etc.) or if you still prefer an analog recorder, the Symetrix 488 DYNA-Squeeze can make your job easier and make you sound better. With almost two decades of experience designing and manufacturing cutting edge gain controllers, we've come up with a unique product that is unbeatable in performance and price. To DYNA-Squeeze your next recording, contact us now for the name of your nearest Symetrix dealer.

FEATURES

- Higher average recording levels
- Increased "presence"
- Level matching to digital recorders
- Minimum component signal path for sonic transparency



Applications

ALBUM TRACKING

JINGLE PRODUCTION

AUDIO FOR VIDEO PRODUCTION

USE WITH ADAT™, DA-88™, PROTOOLS™ AND OTHERS

LIVE RECORDING

PA SYSTEM SUBGROUPS

488

488 Dyna-Squeeze™

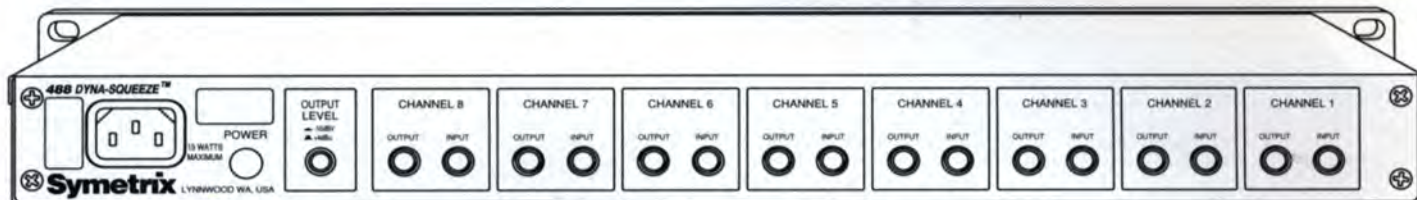

Specifications

Audio

Inputs	Eight, balanced bridging
Outputs	Eight, unbalanced, zero ohm source
Maximum input level	+24 dBu
Maximum output level	+18 dBu into 2 k ohms
Frequency Response	+0,-1 dB, 20 Hz-20 kHz
THD+noise	<0.05%, 0 dBu in, 10 dB gain reduction, 1 kHz
Maximum compression	38 dB
Nominal output level	+4 dBu, -10 dBV (switch selectable)
Output Noise	-90 dBu, broadband
Dynamic Range	>110 dB
Crosstalk	-100 dB, +20 dBu in, 20 Hz- 20 kHz
Input common mode rejection	>40 dB @ 1 kHz
Attack time	1.5 milliseconds
Release time	1.2 seconds
Threshold range	-40 dBu to +10 dBu
Ratio	2.5:1 (soft knee)
Output trim range	-10 dB to +10 dB

Physical

Input connectors	1/4" tip-ring-sleeve
Output connectors	1/4" tip-sleeve
Polarity	tip of input jack is high, ring is low, sleeve is ground tip of output jack is high, sleeve is ground
Chassis size	1.75"H x 19" W x 7.25" 4.45 cm H x 48.3 cm W x 18.4 cm D
Shipping weight	8 lbs, 3.63 kg

Electrical

Power	117V ac, nominal, 105-130V ac, 50-60 Hz 230V ac, nominal, 207-255V ac, 50 Hz
Power Consumption	15 watts

In the interest of continuous product improvement, Symetrix, Inc. reserves the right to alter, change, or modify these specifications without prior notice.
©1995, Symetrix, Inc. All rights reserved.

Highlights

Higher Average Recording Levels. The 488 can easily increase average recording levels on your digital or analog tape recorder by 10 dB (or much more if you like) with virtually no side effects. In fact...

Increased Presence. As DYNA-Squeeze increases average levels, musical articulation is magnified. Subtle sounds become more "up front", more "present".

Level matching. Many professional mixing consoles have output levels that are much hotter than digital

recorder inputs. This forces engineers to operate the board at uncomfortably low levels. With the flip of a switch the 488 matches most any console to most any digital recorder.

Minimum Component Signal Path. In a typical automated console you can find 12-24 opamps and several VCA's in the signal path from mic input to bus output. The DYNA-Squeeze signal path is sonically pure: 2 opamps, 1 VCA. That's it!

Architects and Engineers Specifications

The Eight Channel Compressor/Interface shall be a high performance, eight-input, eight-output compressor and signal level interface. It shall occupy a single rack space. (1U)

The unit shall contain eight independent compressors. All eight channels are operated from a single set of controls. It shall not be possible to alter the settings of one channel relative to the remaining channels.

An overall threshold control shall determine the threshold of the entire unit simultaneously. An overall gain trim control shall alter the overall gain of all channels simultaneously over a range of ± 10 dB. A single in/out switch shall disable all channels simultaneously. The output signal level shall be switchable between +4 dBu and -10 dBV via a single switch for all channels.

Each channel shall have a single balanced input and a single unbalanced output. All input and output connectors shall utilize tip-ring-sleeve (TRS) 1/4" jacks. The inputs shall be active balanced bridging designs incorporating LC lowpass filters for RFI suppression.

Independent four-element bargraph displays shall be provided for monitoring the degree of gain reduction for each channel.

The compressor shall be capable of operating by means of its own built-in power supply connected to 117V nominal ac (105-130V) 50/60 Hz. The unit shall be a Symetrix, Incorporated model 488 DYNA-Squeeze™.

488

Symetrix

Symetrix Inc. • 14926 35th Ave. W. • Lynnwood, WA 98037 • USA • Tel: (206) 787-3222 • FAX: (206) 787-3211 • e-mail: 102102.1126@compuserve.com

www.SteamPoweredRadio.Com

450 Mic/Line Mixer

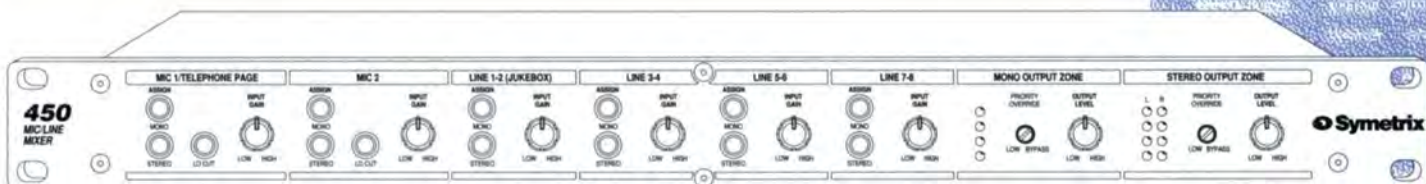

THE 450 MIC/LINE MIXER satisfies the requirements for paging microphone and mono/stereo line mixing in clubs, restaurants, hotels, conference facilities, houses of worship or anywhere that multiple audio inputs must be combined and distributed. The compact one-rack-space mixer accepts two microphone inputs (with +48V phantom power and low frequency filters) and four stereo (or mono) line inputs.

Each input may be assigned to a stereo output zone, a mono output zone or both. A unique hierarchical priority structure permits one of the mic inputs and/or one of the line inputs to have priority over the other sources assigned to the same zone. For example, in a typical configuration, a paging microphone assigned to the stereo zone will have priority over a background music source in that zone. A jukebox in the same zone will have priority over the background music, but the paging signal will retain ultimate priority and force muting of both the jukebox and the background music whenever the page mic is used.

As a result of its inherent flexibility the 450 is a perfect low-cost solution for many small system requirements. By accepting audio inputs from virtually any type of audio source and selectively routing to either the mono or stereo output zone, the 450 can save you time and money in the design and installation of your next project.

Please call or fax us today for more information and a copy of our free application notes.

FEATURES

- Separate stereo and mono output zones
- 4 stereo inputs (may be used as mono)
- 2 mic inputs with +48v phantom power
- 2 inputs have priority override capability
- Remote volume control capability
- Uncompromised sound quality
- Mic 1 input accepts telephone page signal

Applications

RESTAURANTS/PUBS/BARS

CONFERENCE ROOMS

MULTI-ZONE PAGING

CHURCH/SCHOOL
PUBLIC ADDRESS

SUBMIXING FOR
PERFORMANCE VENUES

HOTEL/CONVENTION FACILITIES

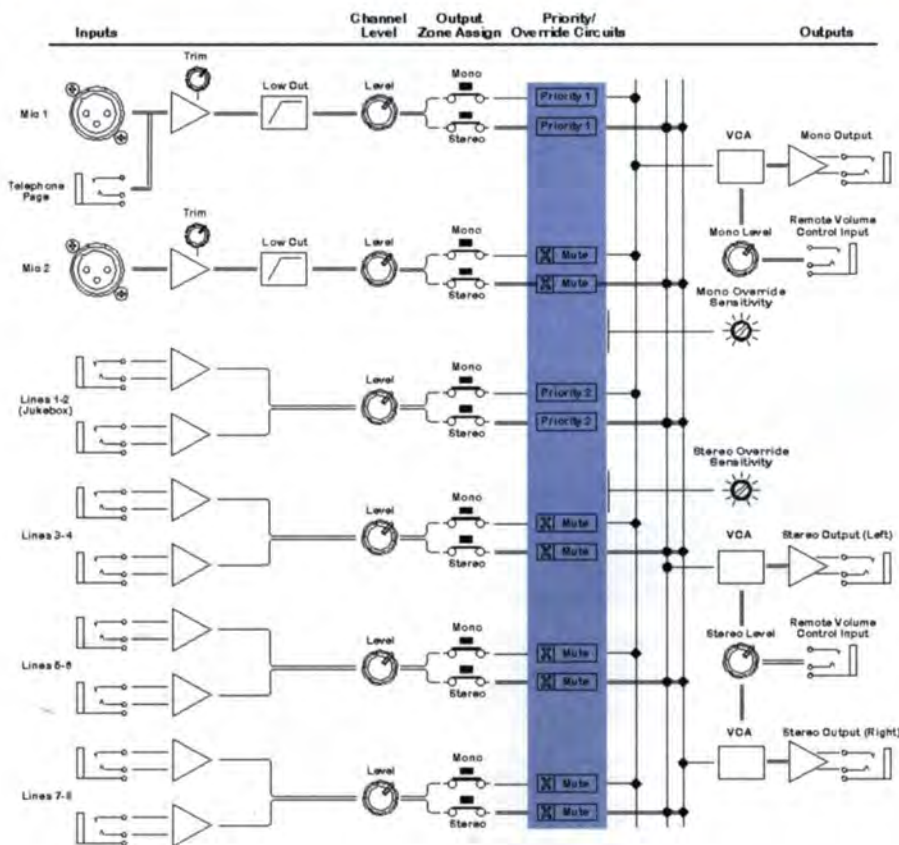

450

450 Mic/Line Mixer

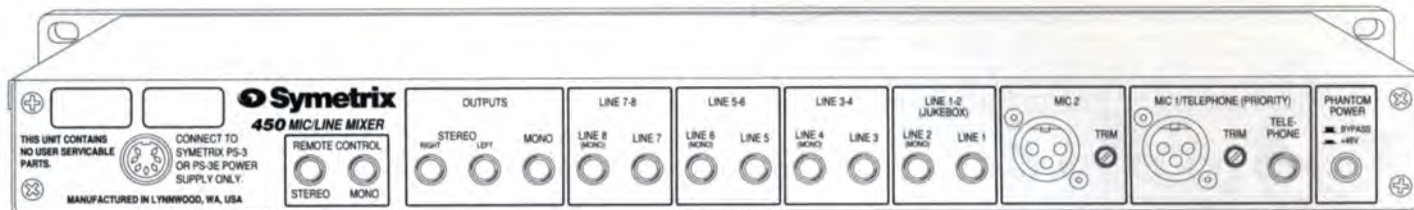

Specifications

Audio

Microphone Inputs	2 balanced low impedance
Mic common mode rejection @1kHz, 1v RMS	>85 dB
Phantom power	+48V (10ma per input max)
Line Inputs	four, stereo, balanced
Line input impedance	>10k ohms, balanced
Common mode rejection @1kHz, 1v RMS	>85 dB
Maximum line input level	+24 dBu, balanced +18 dBu, unbalanced
Line input common mode rejection @1kHz, 1V RMS	>40 dB
Frequency response, any input to any output	±1dB, 20 Hz-20 kHz

Physical

Microphone inputs	XLR female (pin 2 high)
Line inputs and outputs	1/4" tip-ring-sleeve (tip is high)
Remote volume control inputs	1/4" tip-ring-sleeve
Chassis size	1.75"H x 19" W x 7.5" D
	4.45cm H x 48.3cm W x 19.1cm D
Shipping weight	8 lbs, 3.64kg

Electrical

Power	117V ac nominal, 95-130V ac, 50-60Hz (UL listed) 230V ac, nominal, 165-255V ac, 50Hz (TUV approved)
Power Consumption	15 watts, maximum

In the interest of continuous product improvement, Symetrix, Inc. reserves the right to alter, change, or modify these specifications without prior notice.
© 1995, Symetrix, Inc. All rights reserved.

Highlights

Superb audio performance. All circuits in the 450 have been carefully designed to meet or exceed the sonic performance of the finest studio quality mixers.

Versatile and hassle-free. Accepts microphone or line level inputs and everything inbetween. It doesn't matter what your audio source is, what impedance it is, or where it's coming from. Chances are you can plug it straight into the 450 and get the right level.

Reliable. The 450 is manufactured using the highest quality industrial grade components. We rigorously test each and every parameter of every unit leaving our factory. You can expect years of trouble free operation from the 450.

Backed by a company that cares. With almost twenty years in the professional audio industry, Symetrix strives to support each and every customer in any way that we can. We care. We're in it for the long haul.

Architects and Engineers Specifications

The audio microphone and line mixer shall be a high performance unit occupying a single rack space (1U).

The unit shall have two low impedance, balanced microphone inputs with connection via female XLR. Each microphone input shall have a rear panel gain trim potentiometer which varies the gain of the microphone preamplifier over a 35dB range from 25 to 60 dB. Microphone input #1 shall also accept balanced or unbalanced line level signals from a telephone system (nominal sensitivity of -15dBv) via a 1/4" phone jack connector.

Associated with each microphone input shall also be a level control potentiometer whose purpose is to establish the level of the microphone channel as it is mixed to either a mono output zone, a stereo output zone, or both simultaneously. Each microphone input shall also have a first order low cut filter with a 100 Hz rolloff frequency.

The mic/line mixer shall have four stereo, balanced line level inputs. Each input shall be assignable to either a monaural output zone, a stereo output zone, or both. Associated with each line input shall be a level control potentiometer whose purpose is to establish the level of the line level input signal as it is mixed to either a mono output zone, a stereo output zone, or both simultaneously.

Microphone input number one and line input number one shall serve as dedicated priority inputs meaning that audio applied to either of these inputs may override (duck) mic input #2 and line inputs #2,3, and 4 provided they are assigned to the same output zone as the priority input is assigned. Independent master output level controls shall be provided for both the monaural output zone and the stereo output zone. For each output zone a potentiometer shall be provided which establishes the sensitivity (threshold level) at which the priority input overrides the other inputs.

Independent means shall be provided to remotely control the output level of the mono output zone and the stereo output zone. Rear panel jacks shall be provided to accept connections from standard 50K linear potentiometers for this purpose. When wired for remote control, the front panel output zone controls shall be disabled.

The mic/line mixer shall be a Symetrix, Inc. model 450 Mic/Line Mixer.

450

Symetrix

www.SteamPoweredRadio.Com

Symetrix Inc. • 14926 35th Ave. W. • Lynnwood, WA 98037 • USA • Tel: (206) 787-3222 • FAX: (206) 787-3211 • e-mail: 102102.1126@compuserve.com

425 Dual Compressor/Limiter/Expander



IN DESIGNING THE 425 DUAL COMPRESSOR/LIMITER/EXPANDER, Symetrix engineers aimed for audio control that would work for a variety of audio applications. Providing you with the right combination of tools is what IDP (Integrated Dynamics Processing) is all about. IDP makes all three processing modes (compression, limiting, and downward expansion) available all the time: no switching between sections, no patching in extra boxes.

If background noise, tape hiss, or pickup hum is the problem, eliminate them with the downward expander. The 425 uses a true downward expander, not a so-called "soft gate". A downward expander won't chop off the transients and decays like a gate would, yet it can work just as effectively for reducing those noises between sounds. A noise gate works like an on/off switch while a true downward expander works like an engineer riding a fader, following the signal as it decays.

While the downward expander is taking care of the noise, the 425's compressor section allows you to apply the right amount of compression from a gentle squeeze to a hard squash without "pumping" or "breathing". And because the separate limiter section is guarding against peaks that would cause problems, it frees the compressor section to be set for the job of compression and not protection. Trying to set a typical compressor for multiple jobs like this usually results in settings that aren't optimized for either application. The limiter protects against problems and the compressor smooths signals out for a silky, listenable finish.

Symetrix uses powerful, streamlined controls that make the 425 easy to set up and operate. Appropriate parameter adjustments allow you to match the settings to the situation. You decide the way you want the 425 to react to the signals, not some predetermined ratios or thresholds.

The 425 is easy to install, providing both XLR balanced and 1/4" line level connectors. The UL approval means that it can fit into any installation with confidence.

In the final analysis, Integrated Dynamics Processing means clean, quiet sound that meets professional demands in any situation. High-quality components and "minimal signal path" circuitry make the 425 exceptionally transparent. The Symetrix name on the front panel guarantees it all.

Features

- Integrated Dynamics Processing includes downward expander, compressor and limiter
- Stereo-coupled or two-channel operation
- Individual LED meters for each processing section and output
- Separate threshold controls for expander, compressor and limiter
- Sidechain input/output
- Balanced XLR and unbalanced 1/4" line level connections



If You Didn't Get This From My Site,
Then It Was Stolen From...
www.SteamPoweredRadio.Com

Applications

RECORDING

Guards levels, reduces unwanted noise, contains dynamic range, helps eliminate the risk of digital distortion in recording to digital mediums

SOUND REINFORCEMENT

Protection for amps and speakers, improve separation using downward expander, helps keep control of group levels

BROADCAST

Improves the quality of dubs and transfers, insures that feeds from satellite and phones are kept clean and level

SPECIAL EFFECTS

Ducking, "vocal stressing", and other dynamic effects achievable through the sidechain insert

425

Symetrix

425 Dual Compressor/Limiter/Expander

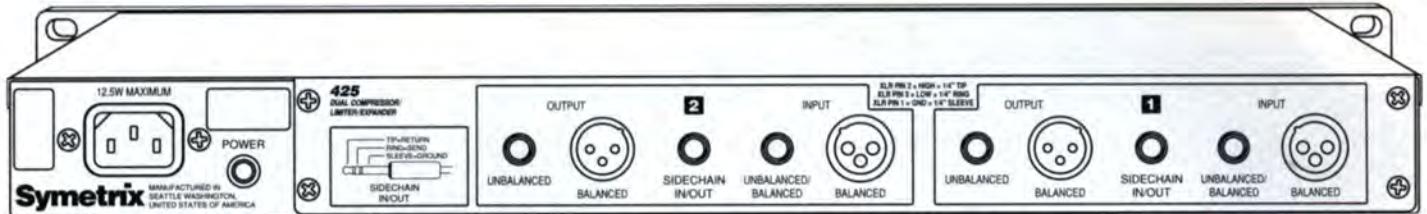

Specifications

Frequency Response	10 Hz to 60 kHz +0, -3 dB	CMRR	Greater than 40 dB
THD+N	.02%, 4 dBu in, +18 dBu out, 0 dB gain reduction, 20 Hz to 20 kHz, 30 kHz low-pass filter .04%, 4 dBu in, +4 dBu out, 10 dB gain reduction, 1 kHz, 30 kHz low-pass filter	Compressor Type	RMS responding
Maximum Output	+25 dBu, balanced +23 dBu balanced (600 ohms) +20 dBu, unbalanced +18 dBu unbalanced (600 ohms) at onset of clipping (1% THD)	Attack Time	2 mS
Maximum Gain Reduction	40 dB	Release Time	180 mS to 2.5 S long-term
Maximum Input	+20 dBu, balanced +20 dBu, unbalanced	Auto Release	20 mS to 1 sec. (20 mS burst)
Input Impedance	43 kilohms, balanced 30 kilohms, unbalanced	Threshold	-40 dBu to +20 dBu (bypass)
Output Impedance	300 ohms balanced 150 ohms unbalanced	Ratio	1:1 to 10:1
Load Impedance	600 ohms minimum, balanced/unbalanced	Limiter	
Output Noise	-90 dBu, measured at balanced output, input terminated in 600 ohms, 20 kHz rolloff in analyzer	Attack Time	200 μ s
Dynamic Range	115 dB (difference of maximum output and noise floor)	Release Time	100 mS
Crosstalk	-95 dB 1k, -95 @ 10k, +4 dBu in, remaining channel terminal terminated in 600 ohms, 20 kHz rolloff in analyzer	Threshold	-10 dBu to +20 dBu
Sidechain	100-ohms source impedance, 6800-ohms input impedance, TRS jack, tip is return	Ratio	20:1
		Expander	
		Attack Time	4 mS
		Release Time	250 mS to 5s
		Threshold	0 dBu to -40 dBu (bypass)
		Ratio	1:1.5
		Physical	
		Connectors	input: XLR, 1/4" TRS output: XLR, 1/4" TRS sidechain: 1/4" TRS (one)
		Polarity	pin 2 of XLR is hot, tip of TRS jack is hot
		Size	1.75"H x 19"W x 7.25"D 4.45cm H x 48.3cm W x 18.4cm D
		Shipping Weight	8 lbs (3.63kg)
		Power	10W, 120 V ac, 60 Hz 10W, 220 V ac, 50 Hz

©1995 Symetrix, Inc. Specifications subject to change without notice.

Architects and Engineers Specifications

The Compressor/Limiter/Expander shall be a dual channel model that controls the dynamic range of wide range, wideband audio signals, providing compression, peak limiting, and downward expansion simultaneously. The unit shall occupy one rack space (1U).

The threshold of the compressor section shall be adjustable over a range of -40 dBu to +20 dBu via a front panel control. When the control is fully clockwise the section will be in bypass mode. The input-to-output ratio will be adjustable from 1:1 to 10:1. Control of the compressor release time shall be program dependent within a range set by the front panel release control. The compressor section will have a dedicated eight segment LED ladder that will display the gain reduction amount.

The Compressor/Limiter/Expander shall contain an integral peak limiter having a 20:1 ratio and adjustable threshold level. A green LED indicator shall be provided to indicate peak limiter activity.

A front panel switch, with LED indicator, shall select between dual mono and stereo master/slave operation. Each channel shall have a bypass switch which defeats all front panel controls for that channel.

The Compressor/Limiter/Expander shall also contain a downward expander having a 1:1.5 expansion ratio with threshold, and release time controls. A four segment LED display shall be provided to indicate the amount of downward expansion.

The inputs shall be active balanced bridging designs terminated with 3-pin XLR (AES/IEC standard wiring), and 1/4" TRS female. The input circuitry shall incorporate RFI filters. The outputs shall be active bal-

anced designs having equal source impedances and terminated with 3-pin XLR (AES/IEC standard wiring), and 1/4" TRS female.

The balanced inputs shall accommodate +20 dBu signals without distortion, and the balanced outputs shall be capable of delivering +23 dBm into a 600-ohm load.

Overall frequency response shall be 10 Hz to 60 kHz (+0 dB, -3 dB). THD+N shall be 0.02% measured under the following conditions: +4 dBu input, +18 dBu output, BYPASS switch out, 20 Hz to 20 kHz, 30 kHz low-pass filter, 0 dB gain reduction. Residual noise output shall be no greater than -90 dBu, measured with a 20 kHz noise bandwidth, input terminated in 600 ohms.

When the unit is inoperative (either by loss of power, or via the BYPASS switch), the inputs and outputs shall be wired together. There shall be no transients transmitted to the output terminals during either turn-on, turn-off, or bypass operation.

Access to each channel's sidechain shall be provided via a single 1/4" TRS female connector. The ring connection shall be the sidechain output and the tip connection shall be the sidechain return.

The unit shall be capable of operating by means of its own built-in power supply connected to 117V nominal ac (105 to 130V) 50/60 Hz (230V nominal, 207 to 253V ac, 50 Hz where applicable). The AGC shall be Listed by Underwriters Laboratories, Inc. (UL) or other equivalent nationally recognized safety testing agency.

The unit shall be a Symetrix Incorporated model 425 Dual Compressor/Limiter/Expander.

425

Symetrix

www.SteamPoweredRadio.Com

Symetrix Inc. • 14926 35th Ave. W. • Lynnwood, WA 98037 • USA • Tel: (206) 787-3222 • FAX: (206) 787-3211 • e-mail: 102102.1126@compuserve.com

422 Stereo AGC-Leveler



HAVE YOU EVER NOTICED how audio comes in all shapes and sizes? There's loud audio. There's quiet audio. There's pretty audio. There's ugly audio. There's music. There's speech. There are CD's mastered at drastically different levels. There are movie sound tracks where the effects are too loud and the dialog so soft you can't understand the words.

Have you ever been on an airplane trying to watch the movie and found yourself repetitively turning the volume up and down and up and down again? The background noise is high and the movie sound track is either uncomfortably loud or buried in the background noise. And you ask yourself, "Why in this age of really hi-tech audio systems can't I enjoy the audio track for this movie I'm trying to watch?"

Well, back on earth if you want to free yourself from the ups and downs of unpredictable audio program levels then you need a Symetrix 422 Stereo AGC-Leveler. It's easy medicine. The 422's controls are simple and intuitive, making setup a nonevent. But the real payback is in the *sound* – the 422 converts "all over the map" signal levels into smooth, intelligible, constant level audio.

Why can't I use a compressor/limiter to do the same thing? When it comes to maintaining constant output levels, a compressor/limiter can only do half the job, at best. Sure, when things get too loud the comp/limiter kicks in, but what about when things get too soft? A comp/limiter is a "top down" device – it pushes down from the top, preventing overload and distortion in subsequent stages. But what about the "bottom up" part of the deal? What about the low level signals that contribute so much to the intelligibility of speech and the enjoyment of music?

The 422 Stereo AGC-Leveler solves the problem. The 422 does it all. It makes the loud sounds quieter and the quiet sounds louder. And it does it with finesse. You'll be amazed. The 422 works without the side effects audio professionals have been conditioned to expect from compressors and limiters. Noise, pumping, and modulation are not part of the 422's vocabulary. Bringing the volume to where *you* want it and keeping it there is what the 422 is designed to do.

The 422 may be used in virtually any type of sound system for processing just about any kind of audio. Insert the 422 at a convenient patch point where you have "line level" audio. We don't hassle you with

annoying "-10,+4" level matching switches – just give the 422 a basic line (not mic level) signal and you're ready to go.

The 422 is easy to use. There are basically only four controls. The first and most important is the target level control. As the name implies, this control sets the volume where you want it. The 422's unique input over output parallel VU meters simultaneously show you the unmodified input signal on top and the result of your target level setting just below it. The detector control increases the "sensitivity" of the AGC. As you turn it counterclockwise the 422 gently "reaches down" for the lower volume audio and brings it up. Set the target level and detector, then use the ratio control to increase or decrease the amount of leveling. At high ratios the program density increase results in a more "present" or "in your face" sound. At low ratios the 422 performs subtle, yet effective, automatic gain riding. Lastly, adjust the *peak limit* control to create an absolute "ceiling" level. This is an especially handy feature for protecting amps and speakers in discos where DJ's often succumb to a disease known as "volume creep" as the evening wears on.

The 422 Stereo AGC-Leveler is a remarkably sophisticated volume controller that is amazingly easy to use and brought to you by a company with almost twenty years experience in the design of dynamic range controllers. If you want to know more please call or FAX today.

Features

- **'Target Level' control makes setup simple and quick**
- **Peak limiter prevents sound system overload or tape distortion**
- **Parallel input/output LED meters show exactly what's happening**
- **Remote bypass port**
- **Solid, reliable, built to last**

Applications

CONSTANT AUDIO LEVELS FOR:

RADIO, TELEVISION

MUSIC MIXDOWN

SATELLITE, CABLE VIDEO

DISCOS

THEATRES

BARS, RESTAURANTS

TAPE DUPLICATION

FOREGROUND/BACKGROUND MUSIC

422

422 Stereo AGC-Leveler

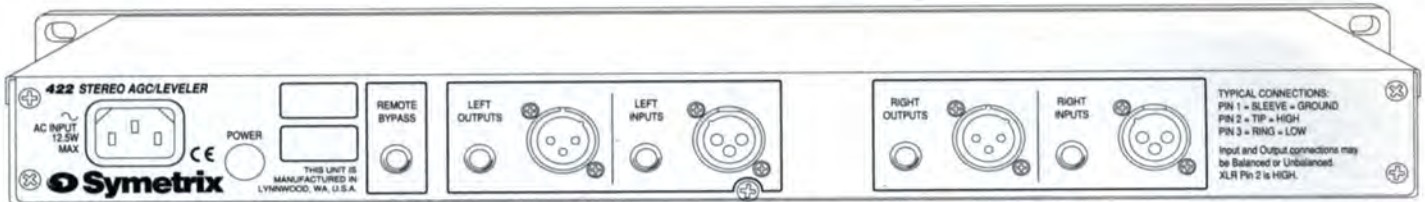

Specifications

Audio

Inputs	Stereo, balanced bridging or unbalanced
Outputs	Stereo, balanced or unbalanced
Maximum input level	+24 dBu
Maximum output level	22 dBu into 600 ohms
Frequency Response	0dB \pm 1dB, 20 Hz-20 kHz
THD+noise	.05%, 0dBu in, 10dB gain reduction, 1kHz
Output Noise	-90 dBu, broadband
Dynamic Range	>110 dB
Crosstalk	-60 dB, +20 dBu in, 20 Hz-20 kHz
Input common mode rejection	40 dB @ 1kHz
AGC Detector range	-70 dBu to 0dBu
Ratio	1:1 to 5:1
Target level range	30 dB
Limiter Threshold	-15 dBu to +25 dBu
Limiter Ratio	>15:1

Physical

Input connectors	1/4" tip-ring-sleeve, XLR, & RCA
Output connectors	1/4" tip-ring-sleeve, XLR, & RCA
Polarity	tip of input jack is high, ring is low, sleeve is ground tip of output jack is high, ring is low, sleeve is ground
Chassis size	1.75"H x 19" W x 5.75 D
Shipping weight	8lbs, 3.63kg

Electrical

Power	117V ac, nominal, (105-130V ac), 50-60Hz UL listed (external in-line power supplies); 230V ac nominal (207-255V ac), 50Hz TUV approved
Power Consumption	12 watts

In the interest of continuous product improvement, Symetrix, Inc. reserves the right to alter, change, or modify these specifications without prior notice.

©1995, Symetrix, Inc. All rights reserved.

Architects and Engineers Specifications

The Automatic Gain Controller (AGC-Leveler) shall be a stereo model that reduces the dynamic range of wide range, wideband audio signals and provides peak limiting. The AGC shall occupy one rack space (1U).

The AGC-Leveler shall be capable of controlling audio signals ranging from -70 dBu to +24 dBu and reducing their range by an input/output ratio of from 1:1 to 5:1. A target output level control shall be provided to shift the level of the output signal over a nominal \pm 15dB range. The release time of the AGC shall be controlled by the presence and nature of input signals.

The AGC-Leveler shall also contain an integral peak limiter having at least a 15:1 ratio and adjustable threshold level. A green LED indicator shall be provided to indicate peak limiter activity. The peak limiter threshold shall determine the absolute maximum output amplitude of the AGC/Leveler regardless of other conditions.

The AGC-Leveler shall provide identical peak responding input and output level meters. These meters shall be capable of responding to signals ranging from -48VU to +12VU (-50 dBu to +16 dBu). An output clipping indicator shall be provided.

The inputs shall be active balanced bridging designs terminated with 3-pin XLR (AES/IEC standard wiring) female and 1/4" (tip-ring-sleeve) jacks.

The outputs shall be active balanced designs terminated with 3-pin XLR (AES/IEC standard wiring) male and 1/4" (tip-ring-sleeve) jacks.

Overall frequency response shall be 20 Hz to 20 kHz, \pm 1dB, measured at +4dBu output. There shall be no more than 0.02% harmonic distortion measured under the following conditions: +4dBu input, +4dBm output, BYPASS switch out, 1000Hz test frequency. Residual noise output shall be no greater than -90 dBu measured in a 20 kHz noise bandwidth with an rms responding meter.

When the unit is inoperative (either by loss of power, or via the BYPASS switch,) the inputs and outputs shall be wired together. A REMOTE BYPASS facility shall be provided whereby an external contact closure shall force the AGC-Leveler into BYPASS mode.

The 117V nominal ac (105 to 130V) 50/60 Hz supply shall be UL listed. The 230V nominal ac (207 to 253V ac) supply shall be TUV approved, with an external in-line power supply.

The AGC-Leveler shall be a Symetrix, Incorporated model 422 Stereo AGC-Leveler.

422

Symetrix

www.SteamPoweredRadio.Com

Symetrix Inc. • 14926 35th Ave. W. • Lynnwood, WA 98037 • USA • Tel: (206) 787-3222 • FAX: (206) 787-3211 • e-mail: 102102.1126@compuserve.com

421m AGC-Leveler with Mic/Line Input



THE SYMETRIX 421m AGC-LEVELER is a sophisticated audio gain controller, but what it does is simple: it makes quiet sounds louder and loud sounds quieter—just like a skilled audio engineer. Set the desired, “target” output level and the 421m gently boosts signals that drop below your target, and smoothly pulls back those that rise above it. Operation is automatic, precise, and completely transparent—no pumping or breathing. The user sets the range of control and the 421m works exactly as instructed—automatically.

Any audio application where clarity and intelligibility are important can benefit from a 421m. Everybody speaks at different levels and works at varying distances from the microphone. Intelligibility can vary from person to person or moment to moment. How do you put everyone on the same level? Hire a trained sound engineer... or use a 421m. The 421m is equally well suited to processing program material (for stereo applications two 421m's may be linked). Program levels from soundtracks, CD jukeboxes, or broadcast audio go up and down unpredictably. The 421m gently and unobtrusively raises the low level audio and compresses the high level audio without side effects. Its flexible input configuration will handle just about any audio source, from studio microphones to telephone-based paging systems. Installed sound systems, recording studios, and broadcast facilities all benefit from increased intelligibility—and that's what the 421m is all about.

Here's how it's done. The 421m's Automatic Gain Control (AGC) section incorporates a smooth-acting leveling amplifier working in conjunction with a make-up gain stage coupled to the ratio control. Increasing the ratio on the leveling amplifier makes your program denser, but your output level stays constant no matter what happens at the input. Roughly translated, this means that you could speak two feet from a microphone and have the same volume output that you had at 6 inches (and vice versa). To deal with existing system or program noise, the 421m offers a full-featured downward expander section to effectively quiet the output when input signal is absent. A separate “brick wall” peak limiter provides speaker protection in PA systems and overload prevention in broadcast or transmission applications. Last but not least, switchable speech curve filters have been incorporated to optimize the 421m for voice range performance.

What really sets the 421m apart is the way its “smart” circuitry reacts to real-world situations. Previous AGC designs often proved troublesome because they would confuse noise and feedback with the desired program signal, boosting noise or cutting off soft-spoken phrases. These problems are eliminated by the 421m's proprietary Auto Release Monitor circuit, which instantly distinguishes the difference between “real” signals (music and speech), noise and feedback.

The 421m's metering system is one key to its simple setup and operation. Parallel LED displays show input compared to output. It is quickly obvious if the 421m is adding gain to your signal or subtracting. Because you can hear and see the net results of the leveling action the guess work is taken out of setup.

Flexible, accurate and trouble-free automatic gain control has always been a good idea. Now, with the pace-setting 421m, Symetrix makes it a cost-effective reality. Please call or FAX today for more information on how to use a 421m in your next project.

Features

- Target oriented AGC-Leveler
- Final stage limiter
- Downward expander with Auto Threshold
- Line and mic inputs
- 125 Hz and 6 kHz speech curve filters
- Parallel input/output metering
- Stereo linkable



Applications

- HOUSE OF WORSHIP
- AUDITORIUM
- PUBLIC ADDRESS/PAGING
- RECORDING STUDIO
- TELECONFERENCING
- RADIO/TV BROADCAST
- TAPE DUPLICATION

421m

 **Symetrix**

421m AGC-Leveler with Mic/Line Input

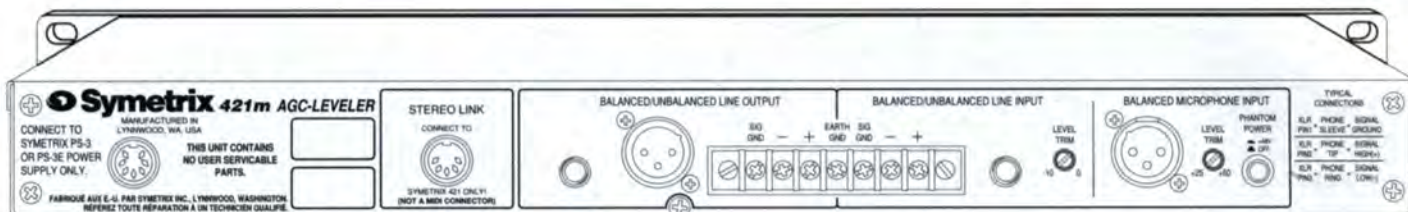

Specifications

Connectors

Line Inputs	1/4" TRS jack and screw terminals 20k balanced bridging.
Mic Input	XLR-female, 10k balanced bridging
Outputs	XLR-male, screw terminals, 200-ohms source impedance, differentially balanced, +23 dBm maximum level TS phone, unbalanced, +18 dBm maximum level
Bypass	Relay controlled, hard-wire bypass in power-off and bypass conditions.
Sidechain	TRS phone, unbalanced send and receive, 1000-ohm source impedance, 10k input impedance. Tip = receive, Ring = send.

Downward Expander

Ratio	1:2
Threshold	-50VU (bypass) to -20VU (Auto Threshold)
Attack Time	1 ms
Release Time	Program dependent, .3 - 3.5 seconds depending on amount and duration

AGC-Leveler

Ratio	1:1 to 4:1
AutoRelease Threshold	-70 dBu to -30 dBu
Attack Time	approximately 1 ms
Release Time	Program dependent, 500 ms-5 seconds depending on amount and duration.

Target Output

Range	+20 dB
Peak Limiter Ratio	10:1
Threshold	-15VU to +23VU (bypass)
Attack Time	1ms for 90% gain reduction
Release Time	.8 seconds

Mic Preamp

Gain Range	+15 dB to +45 dB
Impedance	10k Ohms
Max Input Level	+8dBu
THD +noise (gain control fully CW)	-85 dBu
Phantom Power	48V(+2)
CMRR	>-80 dB (10 Hz - 20 kHz)

Sonics

Frequency Response	20 to 50 kHz, +4dBm (+0, -1dB) (+0, -3dB mic)
Harmonic Distortion	<0.05% 20 Hz to 20 kHz, +4dBm, 30 kHz bandwidth. Typically <0.01% @ 1000 Hz.
Residual Noise	-90 dBu, 20 kHz noise bandwidth, rms responding meter

Speech Curve

Type	Switch selected cutoff filters allow tailoring LF and/or HF response for speech applications.
Frequencies	LF = 125 Hz, 12 dB/octave HF = 6kHz, 24 dB/octave

Input/Output Metering

Type	LED Bargraph, 12 steps + clip
Range (min. to max.)	66 dB
Ballistics	peak
Calibration	0 dB = 0VU = +4 dBm = 1.23V

Power

External in-line power supplies:	117V ac, 50 to 60 Hz, 10W (UL listed) 230V ac, 50 to 60 Hz, 10W (TUV approved)
----------------------------------	---

Physical Size

1.75"H x 19"W x 7.25"D (4.45cm H x 48.3cm W x 18.4cm D)
--

Shipping Weight

8 lbs (3.363 kg)

©1994 Symetrix, Inc. Specifications subject to change without notice.

Architects and Engineers Specifications

The Automatic Gain Control (AGC) shall be a single channel model that reduces the dynamic range of wide range, wideband audio signals, providing peak limiting, downward expansion and bandpass limiting filters. The AGC shall occupy one rack space (1U).

The AGC shall be capable of controlling audio signals ranging from -70 dBu to +24 dBu and reducing their range by an input/output ratio ranging from 1:1 to 4:1. The input/output ratio shall be adjustable via a front-panel control. Response speed switching shall be provided to accommodate speech and music sources. A target output level control shall be provided to shift the level of the output signal over a nominal +20 dB range. The release time of the AGC shall be controlled by the presence of input signal and the signal sensor shall be capable of discriminating between music/speech and random noise or pure tones. The threshold level of the signal sensor shall be adjustable via a front panel control and the presence of signals above the threshold setting shall be indicated via a green LED.

The AGC shall also contain an integral peak limiter having at least a 10:1 ratio and adjustable threshold level. A green LED indicator shall be provided to indicate peak limiter activity. The peak limiter threshold shall determine the absolute maximum output amplitude of the AGC-Leveler regardless of other conditions.

The AGC shall also contain an integral downward expander having a 1:2 expansion ratio with threshold and release time controls. Furthermore, the downward expander shall be capable of operating automatically via the signal sensor circuitry. A green LED indicator shall be provided to indicate downward expander circuit activity.

Bandpass limiting filters shall be provided having a lowpass characteristic of 24 dB/octave at 6 kHz and a highpass characteristic of 12 dB/octave at 125 Hz. Both filters shall be capable of being used individually or simultaneously.

The AGC shall provide identical peak responding input and output level meters. These meters shall be capable of responding to signals ranging from -54 VU to +12 VU (-50 dBu to +16 dBu). An output clipping indicator shall be provided.

The AGC shall provide facilities for stereo-coupling two units via a shielded 5-pin DIN male-to-male cable. A front panel switch shall designate which unit is the master and which unit is the slave.

The line level inputs shall be active balanced bridging designs terminated with 1/4" TRS female and screw terminals. The mic level input shall also be an active balanced bridging design using a three pin XLR female (AES/IEC standard wiring). The input circuitry shall incorporate RFI filters. The outputs shall be active balanced designs having equal source impedances and terminated with 3-pin XLR (AES/IEC standard wiring), and screw terminals. A separate 1/4" TRS jack shall provide an unbalanced output.

The balanced line level inputs shall accommodate +24 dBu signals without distortion, and the balanced outputs shall be capable of delivering +23 dBm into a 600-ohm load. The mic level input shall accommodate +8dBu signals. There shall be separate gain trim controls for the mic and the line inputs and the mic input shall provide 48V phantom power.

Overall frequency response shall be 20 Hz to 20 kHz, ±1dB, measured at +4 dBm output. There shall be no more than 0.02% harmonic distortion, measured under the following conditions: +4 dbu input, +4 dBm output, BYPASS switch out, 1000 Hz. Residual noise output shall be no greater than -90 dBm, measured with a 20 kHz noise bandwidth.

When the unit is inoperative (either by loss of power, or via the BYPASS switch), the inputs and outputs shall be wired together. There shall be no transients transmitted to the output terminals during either turn-on, turn-off, or bypass operation.

The AGC shall be capable of operating by means of an in-line external power supply. The 117V nominal ac (105 to 130V) 50/60 Hz supply shall be UL listed. The nominal 230V (207 to 253V ac, 50 Hz) supply shall be TUV approved. The unit shall be a Symetrix Incorporated model 421m AGC-Leveler.

421m

Symetrix

www.SteamPoweredRadio.Com

Symetrix Inc. • 14926 35th Ave. W. • Lynnwood, WA 98037 • USA • Tel: (206) 787-3222 • FAX: (206) 787-3211 • e-mail: 102102.1126@compuserve.com

420 Stereo Power Amplifier



THE 420 STEREO POWER AMPLIFIER is a two-channel power amplifier for use in professional and commercial audio systems. The 420 may be operated as a two channel amplifier with 20 watts (RMS) per channel, or as a single channel amplifier capable of 40 watts (RMS) output (bridged-mono mode). The 420 is intended for use in powering near-field monitors, small reference speakers used for radio or audio for video reference, small paging speakers, multiple pairs of headphones, or as a general purpose line driver/distribution amplifier.

The 420 is easy to install and simple to operate as well. When used as a stereo amplifier, a single ganged potentiometer controls the level of both channels. As a 2-channel amp there's an independent level control for each channel. In conjunction with the level controls each channel has a bright red LED to indicate the onset of clipping.

A front panel MODE switch mono sums (mixes) the two inputs. This feature is handy for broadcast and recording engineers who wish to check the mono compatibility of their signals. Commercial sound engineers can use this feature to mix paging signals or paging and music signals.

In recording studios and other similar applications, the 420 makes an ideal headphone amplifier. You can drive one pair of phones from the front panel jack, or many pairs from the rear panel terminals. In fact, the 420 will drive multiple professional headphone sets such as the AKG K-240 to 122 dB SPL!

While the 420 is compact (1 rack space) and low cost, one should not overlook its impressive performance data. Total harmonic distortion (THD) is less than .04% at 1 watt output (see the back of this page for complete specifications). The 420 is truly a professional amplifier—clean, crisp sound reproduction and total freedom from noise. As an added feature, the 420's relatively low stray field emissions allow it to be racked next to a wide variety of audio and video equipment without adversely affecting the equipment's performance.

As with all Symetrix products the documentation accompanying the 420 is second to none. This means you'll be able to install and begin using the product in no time at all. Our mean time between failure statistics are among the best in our industry, but should you require applications assistance or repair you're backed up by a worldwide network of Symetrix distributors and dealers.

Features

- Compact (uses only 1 rack space)
- 20 watts/channel (stereo)
- 40 watts (mono bridged)
- Mono mix mode
- Front panel headphone jack
- Front panel output mute switch



If You Didn't Get This From My Site,
Then It Was Stolen From...

www.SteamPoweredRadio.Com

Applications

**RECORDING/BROADCAST
STUDIO NEAR FIELD MONITOR
AMP**

**VIDEO SUITE AUDIO MONITOR
AMPLIFIER**

**AUDIO/VIDEO REMOTE TRUCK
MONITOR AMP**

**SMALL PAGING SYSTEM POWER
AMPLIFIER**

**BACKGROUND MUSIC
AMPLIFIER**

**RECORDING/BROADCAST
HEADPHONE SYSTEM AMP**

**GENERAL PURPOSE HIGH LEVEL
LINE DRIVER**

420

Symetrix

420 Stereo Power Amplifier

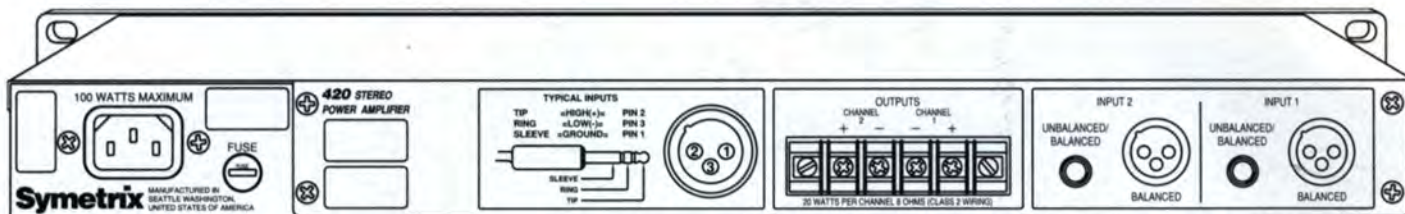

Specifications

Connections

Inputs	XLR-female paralleled with tip-ring-sleeve 1/4" jacks 10 kilohms line-level balanced bridging balanced CMRR greater than 55 dB @ 1 kHz
Outputs	Two, 4 ohms minimum impedance, #6 screw terminals
Maximum input level	+21 dBu
Maximum output (stereo/2-channel)	20 watts RMS, per channel, into a 4- or 8-ohm load
Maximum output (mono bridged)	40 watts RMS into an 8-ohm load
Minimum load	4-ohms, stereo mode; 8-ohms, monobridged mode
Headphone output	100-ohm source impedance, 19V open circuit with speakers off

Performance Data (measured at 120V ac line voltage)

Frequency response	20 Hz to 20 kHz +0, -1 dB
Crosstalk	>60 dB (22 kHz bandwidth)
Sensitivity	0 dBu for 20 watts into an 8-ohm load
Maximum Gain	27 dB
Signal to noise	>95 dB
Typical Distortion	<0.04%, @ 1 kHz, 1 watt into 8 ohms
THD+N	<.2%, 20 Hz to 20 kHz, @ 20 watts into 8 ohms
Clip Indicators	one per channel

Physical

Size (hwd)	1.75 x 19 x 7 inches 4.44 x 48.26 x 17.78 cm
Weight	7.6 lbs (3.5kg) net 10 lbs (4.6 kg) shipping

Electrical

Power requirements	120V ac nominal, 108 to 132V ac 60 Hz, 100 watts
--------------------	---

©1995 Symetrix, Inc. Specifications subject to change without notice.

Architects and Engineers Specifications

The power amplifier shall be a compact, two input, two output, high performance, power amplifier. It shall occupy a single rack space. (1U)

The unit shall be capable of delivering 20 watts per channel into a minimum load of 4 ohms. The unit shall also have a mono-bridge mode which delivers 40 watts into a minimum load of 8 ohms. The inputs shall be active balanced bridging designs terminated with 3-pin XLR (AES/IEC standard wiring), and 1/4" TRS female. The input circuitry shall incorporate RFI filters. The balanced inputs shall accommodate +24 dBu signals without distortion. Screw terminals shall be provided for power amplifier outputs.

THD shall not be greater than 0.04%, @ 1 kHz, @ 1 watt in 8 ohms. Signal to noise ratio shall be greater than 95 dB. Frequency response shall be 20 Hz to 20 kHz (+0 dB, -1 dB).

The power amplifier shall be protected from output short-circuits. A front panel Dual Tracking switch shall allow the Channel 1 gain control to simultaneously control the level of both channels. There shall be a 1/4" tip-ring-sleeve jack mounted on the front panel for stereo headphone output. A front panel switch shall be provided to mute the rear panel output connections. Another front panel switch shall be provided to sum the two input signals and route them to the two gain controls.

Independent clipping indicators shall be provided for each output channel.

The amplifier shall be capable of operating by means of its own built-in power supply connected to 120V nominal ac (108 to 132V) 60 Hz.

The unit shall be a Symetrix Incorporated model 420 Stereo Amplifier.

420

402 Dual Output Delay



THE SYMETRIX 402 DUAL OUTPUT DELAY is a 1 input, 2 output digital audio room delay intended for acoustical alignment of distant speaker systems. This is a necessity due to the delay caused by distance when multiple speakers are spread throughout a large room. In any multi-path situation, large or small, the arrival time for sound arriving at the listener's ears via the room and via the sound system should be matched plus a small additional delay of 10 to 25 ms. The additional delay causes the listener to localize the direction of the sound to that of the first arrival, even if the late arrival is louder. This effect is known as the Haas Effect. The 402 allows you to delay the remote speakers to match the time it takes for the signal coming from the main speakers to reach the listener positioned near the remote speakers. This way the two signals (delayed remote speakers and non-delayed front speakers) arrive at the listener at the same time. This improves intelligibility and helps focus the listener's attention to where the sound is really coming from. The 402 may be used wherever quiet, distortion-free delay is needed: churches, auditoriums, theaters, concert halls, stadiums, and large meeting rooms.

What sets the 402 apart from other delays is the meticulous attention paid to superb audio performance specs. A 64 times oversampling 19 bit A/D converter feeds the signal through a 20 bit digital delay line. The two delayed outputs return through 18 bit D/A converters for total system dynamic range exceeding 100 dB. To further optimize noise performance, the 402 provides a 12 segment input headroom meter which makes it extremely simple for the user to optimize input level settings. Simply put, the sound of the 402 is transparent enough for even the most demanding applications—better than CD quality to say the least.

Setting the delay times of the two outputs is a snap. The user first selects which output to adjust and then either increases or decreases the delay time with the push of a button. A bright seven segment LED displays the delay time. Delay times are displayed in milliseconds, feet, or meters. If desired, the user may measure the distance from the front of house speakers to the placement of the remote speakers and simply enter in the distance in feet or meters. The 402 figures the proper delay time accordingly. There are no cryptic dip switches or multi-page displays to contend with.

Installers can choose XLR balanced, 1/4" phone connectors, or barrier terminal block for the input and outputs. For security, a rear panel lockout switch disables the delay adjustment controls. An optional full panel security cover is available as well.

The 402 is a reliable, easy to use, high performance digital delay, which comes with the Symetrix reputation for quality and support.

Features

- 19 bit A/D, 18 bit D/A's for >100 dB dynamic range
- Two independently adjustable outputs
- Simple, intuitive user interface
- Delay settings stored in non-volatile memory —no battery to replace
- Automatic hard wire bypass in case of power loss
- Front panel lockout
- Barrier terminal, XLR, and 1/4" phone connectors



Applications

TOURING SOUND SYSTEMS

AUDITORIUMS

SPORTS ARENAS (large medium, or small)

CHURCHES

In large churches, the 402 can be used to focus the congregation's attention on the pulpit.

402

402 Dual Output Delay

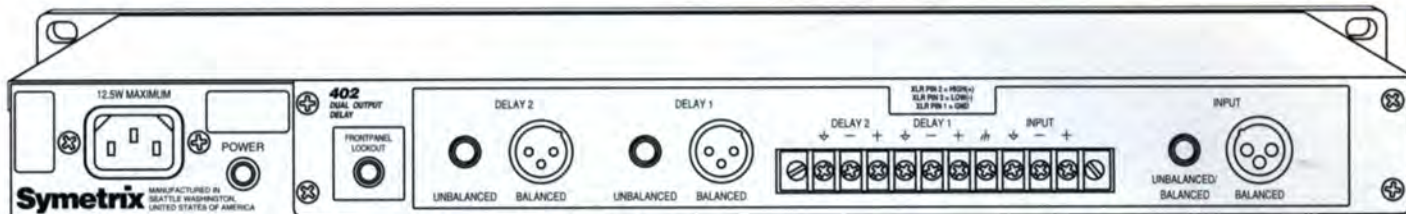

Specifications

Inputs	One, 4700-ohms balanced bridging XLR-female, TRS and screw terminals	Conversion Method	18-bit linear, 64X oversampling times 2
Outputs	Two, 100-ohms source impedance, balanced. XLR-male, TRS and screw terminals	Delay Storage	2 18-bit samples per sample period processed to form a 19-bit word. 20-bit data is stored
Maximum Input Level	+20 dBu	Parameter Storage	EEPROM non-volatile memory Backup battery NOT required Guaranteed for 10,000 parameter changes over 6 years at 4 delay changes/day, every day)
Maximum Output Level	+22 dBu into an open-circuit balanced load +20 dBm into 600 ohm balanced loads	Security	Recessed rear panel lockout switch disables delay increment switches Optional security cover (SC-1)
Frequency Response	12 Hz to 20 kHz ± 1.5 dB	Approvals	Listed by Underwriters Laboratories Inc, control number 2T38
Distortion (THD+noise)	<0.015% @ 1 kHz, 1V RMS	Physical	
Maximum Delay Time	885 milliseconds, 999 feet, 304 meters	Size (hwd)	1.75 x 19 x 7 in 4.44 x 48.26 x 17.78 cm
Headroom Display	12-LED bargraph, 8 green LED's @ 6 dB/step 3 yellow LED's @ 1 dB/step 1 red LED @ true clipping	Weight	7.5 lbs, 3.4 kg (shipping wt.), 6 lbs, 2.7 kg (net)
Dynamic Range	>104 dB. This represents the difference between the largest and smallest signals that will pass through the 402. Measured using 8192 point FFT with Blackman-Harris windowing function	Electrical	
Signal-to-Noise	93 dBfs measured with RMS voltmeter using 20 kHz "Brickwall" filter	Power	117V ac nominal, 105 to 125V ac 50 to 60 Hz 230V ac nominal, 205 to 253V ac, 50 Hz
Sample Rate	48 kHz	Power consumption	12.5 Watts
Converter Type	Sigma-Delta		

©1995 Symetrix, Inc. Specifications subject to change without notice.

Architects and Engineers Specifications

The Digital Delay (DDL) shall be a single input, dual output model that delays its input signal by a precise period before delivering the delayed signal to its output. There shall be two independent delays provided, each sharing a common input, and a common chassis. All signal processing shall occur within the digital domain. Delays utilizing bucket brigade delays, or other analog means shall not be acceptable within the letter of this specification. The DDL shall occupy one rack space (1U).

The DDL shall be capable of delaying an audio signal by up to 885 ms. The delay time shall be adjustable in one millisecond, one foot, or one meter increments. The delay time shall be displayable in milliseconds, feet, or meters and shall be selectable from the front panel at any time during operation. Each channel's delay time shall be stored in non-volatile memory. Provision shall be made to disable the front-panel delay-time adjustment.

The DDL shall indicate its peak input signal level via a multi-step LED ladder having the following indication points: -48, -42, -36, -30, -24, -18, -12, -6, -3, -2, -1, and clip.

The frequency response shall be 12 to 20000 Hz ± 1.5 dB. The dynamic range shall be 104 dB minimum. The dynamic range shall be defined as the difference between the largest output signal possible and the smallest output signal possible. The total harmonic distortion shall be no more than 0.015%, measured at 1 kHz, 1V RMS.

The inputs shall be active balanced bridging designs terminated with 3-pin XLR (AES/IEC standard wiring), 1/4" TRS female, and screw terminals. The input circuitry shall incorporate RFI filters. The outputs shall be active balanced designs having equal source impedances and terminated with 3-pin XLR (AES/IEC standard wiring), and screw

terminals. A separate 1/4" TRS jack shall provide an unbalanced output.

The DDL shall accept input signals ranging from -10 to +4 dBu. The balanced inputs shall accommodate +20 dBu signals without distortion, and the balanced outputs shall be capable of delivering +22 dBu into an open-circuit balanced load, and +20 dBm into 600-ohm balanced loads without distortion. The output level of each output shall be adjustable over the range of -10 to +4 dBu.

When the unit is inoperative (either by loss of power, or via the BYPASS switch), the inputs and outputs shall be wired together. There shall be no transients transmitted to the output terminals during either turn-on, turn-off, or bypass operation.

The Digital Delay (DDL) shall be capable of operating by means of its own built-in power supply connected to 117V nominal ac (105 to 130V) 50/60 Hz (230V nominal ac, 207 to 253V ac, 50 Hz where applicable). Power consumption shall be 12.5 Watts. The DDL shall be Listed by Underwriters Laboratories Inc. (UL) or other equivalent nationally recognized safety testing agency.

The unit shall be a Symetrix Incorporated model 402 Dual Output Delay.

402

SX208 Stereo Compressor/Limiter



THE SX208 STEREO COMPRESSOR/LIMITER is a true stereo dynamic range controller offering both studio sonic performance and ease of operation at a very economical price.

Like all Symetrix compressor/limiters, the half rack sized SX208 gives full sized performance with no objectionable side effects sometimes associated with dynamic range controllers. The heart of the SX208 is built around an industry standard high performance VCA enabling a dynamic range in excess of 110 dB with a typical distortion of less than .03%.

Ease of Operation

By eliminating redundant controls found on competing designs, the SX208 is a step ahead in usability and reliability. Three LED's "tell" the operator when the input signal is below threshold, "right on the money" or too "hot".

SX208 response times (release) are program controlled. The incoming signal itself determines how the unit will behave. Responding quickly to transients and gently to longer term level changes, the SX208 combines the advantages of both RMS and peak detection circuitry. A front panel Fast/Slow response time switch works in conjunction with the program controlled circuitry to adapt to various material types—fast for percussive sounds, slow for smoother signals like vocals or speech.

Optional SX200 Series Accessories:

- SC-2 Security Cover – security cover/filler pane
- PS-2 Power Supply – replacement power supply
- RM-2 Rack Mount – 19" rack mounting shelf

Specifications

Input	balanced bridging
Impedance	>10 kilohms
Maximum Input Level	+18 dBu
Balanced Input CMRR	>40 dB at 1 kHz
Output	balanced
Source Impedance	300 ohms unbalanced, 600 ohms balanced
Maximum Output Level	+20 dBm, 600 ohms, balanced +17 dBm, 600 ohms, unbalanced
THD+N	.03%, +4 dBm, 1 kHz
Frequency Response	20 Hz to 20 kHz, +0, -1 dB
Compressor/Limiter	Soft-knee transition characteristic
Max. Attack	12 dB/ms
Min. Attack	6 dB/ms
Max. Release	10 dB/ms
Min. Release	1 dB/ms
Ratio	1:1 to 20:1
Max. Gain Reduction	40 dB
Controls	System Bypass, Input Gain, Ratio, Response Time Output

Features

- Exceptionally low noise and distortion
- Simple straightforward operating controls
- LED indicators for input level, compression, and clipping
- Balanced or unbalanced signal connection
- UL approved power supply

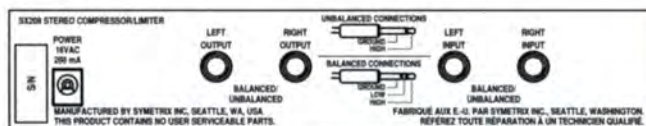

Signal to Noise Ratio	Greater than 92 dB
Dynamic Range	110 dB
Visual Indicators	Threshold, Output Clip, Gain Reduction
Connectors	Inputs and Outputs: 1/4" TRS Phone Jax
Physical Size	1/2 rack unit Chassis 1.5"H x 8.2"W x 6"D Front Panel 8.5"W x 1.75"H
Shipping Weight	5 lbs
Power Requirements	16V ac, 200 ma (Symetrix PS-2 supplied) (Symetrix PS-2 for 110V ac operation, PS-2EP for 220V ac operation)
Accessories	PS-2 Spare power supply RM-2 Two-unit standard 19" rack mount SC-2 Security Cover

©1995 Symetrix, Inc. Specifications subject to change without notice.

Applications

RECORDING

Use the SX208 to normalize levels and prevent distortion. Just a little mild compression can go a long way in the studio when the vocal talent does not utilize "good mic technique"

BROADCAST

In the production room compression can add that "punched up sound" that makes a spot dominate

REINFORCEMENT SOUND SYSTEMS

Used as a high ratio limiter, the SX208 will keep maximum monitor levels in check. The same high ratio settings provide a safeguard for main speaker protection

PAGING SYSTEMS

Set up as a low ratio compressor, the SX208 allows the sound contractor to set up "constant level" paging so that weak and strong voices are heard equally

SX SERIES

208

SX204 Headphone Amplifier

Applications

STUDIO RECORDING

Drive four sets of phones independently, or drive many sets of medium to high impedance phones simultaneously (up to 240 total pairs of 600-ohm phones)

DISPLAYS

Active museum displays, point-of-sale displays, audio guided tours, etc.

BROADCAST

Drive phones loudly enough to penetrate even the most hardened air personalities

REMOTE RECORDING

Drive phones loud enough to overcome headphone leakage

EDUCATIONAL

An inexpensive, durable way to provide a headphone distribution system for A/V learning facilities

IN-EAR MONITORS

On stage monitoring using ear-worn ear speakers



THE MODEL SX204 HEADPHONE AMPLIFIER is a 1-in 4-out amplifier designed to drive multiple headphones of any impedance. Symetrix' proprietary high voltage converter technology gives the SX204 the ability to drive high impedance headphones with the equivalent output voltage of a much larger power amplifier, yet provides more than ample current for low impedance phones. The four stereo outputs automatically adjust output power to accommodate different load impedances. Each of the four outputs has its own set of amplifiers, each with its own output control. Independent amplifiers allow mixing and matching totally different headphone types.

Controls provided are input level, output level for each individual amplifier, and a stereo/mono switch.

The Stereo/Mono switch allows the amplifier to be used several ways. As a "normal" stereo amplifier (with four outputs), the left and right inputs are used for stereo signals, which feed the left and right outputs. Switching to mono with a stereo input provides a quick check of the mono compatibility of a stereo mix.

As a mono amplifier, one signal fed to either input will feed both outputs. Also in mono mode, when two different mono signals are fed to the left and right inputs, they will be combined to feed both the left and right outputs.

The inputs are electronically balanced, but will operate normally in an unbalanced configuration when 2-conductor 1/4" plugs are inserted. The outputs are 1/4" stereo connectors.

Since the SX204 has a half-rack width chassis, two such units may be mounted in a single 1.75" rack space, giving eight individually controlled stereo headphone outputs.

Optional SX200 Series Accessories:

- SC-2 Security Cover – security cover/filler pane
- PS-2 Power Supply – replacement power supply
- RM-2 Rack Mount – 19" rack mounting shelf

Specifications

Inputs	Bridging, balanced/unbalanced, transformerless	Signal to Noise Ratio	95 dB
Impedance	>10 kilohms/leg	Gain	20 dB
Input Connector	1/4" Tip-Ring-Sleeve	Physical	
Max Input Level	+18 dBu	Size	1/2 rack unit
Outputs	4 each, low-Z, 160-ohm source impedance	Size (HWD)	1.75 x 8.5 x 6.5 in
Maximum output level	>50V peak-to-peak into 2000 ohms	Weight	2.5 lbs
Output Connectors	1/4" stereo (x4)	Accessories	
Power Requirements	16V ac, 200 ma (Symetrix PS-2, included)	PS-2	Spare power supply
Audio Performance		RM-2	Two-unit standard 19" rack mount
Frequency Response	20 Hz to 20 kHz, +0, -1 dB	SC-2	Security Cover
THD+N	.01% (1 kHz, 0 dBm, 600 ohms) .02% (1kHz, +24 dBm, 600 ohms)		

Features

- Four independent stereo outputs driven from one stereo input
- Drives high- or low-impedance headphones
- Stereo or mono operation
- Capable of > 50V peak-to-peak output swing into 2000-ohm load
- Individual level controls for each output
- Master input level control
- Balanced or unbalanced signal connection.
- UL approved power supply

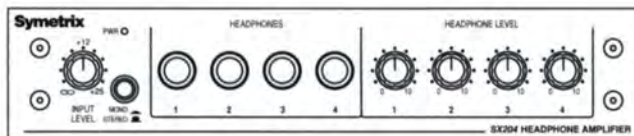

SX SERIES

204

Symetrix

www.SteamPoweredRadio.Com

Symetrix Inc. • 14926 35th Ave. W. • Lynnwood, WA 98037 • USA • Tel: (206) 787-3222 • FAX: (206) 787-3211 • e-mail: 102102.1126@compuserve.com

©1995 Symetrix, Inc. Specifications subject to change without notice.

SX202 Microphone Preamplifier



THE MODEL SX202 DUAL MICROPHONE PREAMPLIFIER is an ultra clean two channel stereo/mono preamp, intended for use in the most critical digital and analog recording situations. In addition, the SX202 is ideally suited for broadcast use, and for general purpose paging or public address applications.

Used in place of older preamp designs, the SX202 offers substantial sonic improvements with its solid stereo imaging (less than 10 degrees phase shift at 20 kHz), excellent transient handling (its positive and negative slew rates are symmetrical), very low noise (approaching the theoretical limit), and almost unmeasurable distortion (.007%).

Its unique combination of features and performance make the SX202 a very versatile product, designed to deliver superior performance in a wide variety of circumstances. Variable gain inputs, with 15 dB pads, allow the SX202 to handle any input up to 14 dBV. Switchable +48 volt phantom power is included for professional condenser microphones. One channel is equipped with a polarity switch, to correct for improperly wired cables or unresolvable mic placement problems. In addition to the individual outputs from each preamp, a left + right output is included to provide a combined mono feed.

Optional SX200 Series Accessories:

- SC-2 Security Cover – security cover/filler pane
- PS-2 Power Supply – replacement power supply
- RM-2 Rack Mount – 19" rack mounting shelf

Features

- Input levels to +14 dBV Left/Right and Left + Right outputs
- Uncompromising sonic performance
- +48 volt phantom powering
- Polarity reversal
- Compact (1/2 rack) and lightweight
- UL approved power supply



Specifications

Inputs			
Type	low-Z balanced, transformerless		
Input Impedance	>3 kilohms		
Maximum Input Level	+14 dBV (with pad)		
Connector	XLR-3		
Clip Indicators	red LED's, fire 4 dB below clipping		
Frequency Response	20 Hz to 20 kHz, +0 dB, -1 dB		
THD+N	0.007% (1 kHz, 0 dBm, 600 ohms) 0.01% (1 kHz, +24 dBm, 600 ohms)		
Signal to Noise Ratio	95 dB (-50 dBV, 150 ohms)		
EIN	-128 dBm (150-ohm source, 20 Hz to 22 kHz 60 dB gain)		
Phantom Power (DIN 45 596)	+48V		
Maximum Gain		60 dB	
Minimum Gain		20 dB	
Outputs			
Type		low-Z	
Output Source Impedance		600 ohms balanced 300 ohms unbalanced	
Maximum Output Level (600 ohms)		+24 dBm balanced +18 dBm unbalanced	
Connectors		1/4" TRS balanced/unbalanced	
Power Requirements	16V ac, 200 ma (Symetrix PS-2 supplied)		
Physical			
Size		1/2 rack unit	
Size (HWD)		1.75 x 8.5 x 6.5 in	

©1995 Symetrix, Inc. Specifications subject to change without notice.

Applications

CONSOLE MIC-PRE REPLACEMENT

Sonic purity of the SX202 often out performs the existing on-board mic-pre's. Use the SX202 and bypass the console mic-pre or go direct-to-tape wherever high performance is critical.

DAT RECORDING

In the studio or in the field, the exceptional clarity of the SX202 allows the punch and presence of your mics to be accurately reproduced.

PAGING SYSTEMS

Use the SX202 to improve the audio quality of existing paging systems. Its super low noise specs bring added clarity to announcements. Use up to 2 mics in different locations.

BROADCAST INTERVIEW SETUPS

The Left + Right outputs of the SX202 allows you to use this mic-pre as a stand alone 2 mic mixer. Ideal for outside control room interviews or 2 mic recordings of table conferences, etc.

SX SERIES

SX202

SX201 Parametric EQ/Preamp

Applications

PARAMETRIC EQUALIZER

Use the SX201 for a problem-solving channel-insert EQ for curves that are beyond the capability of your console's channel EQ

BALANCED LINE DRIVER

Use the SX201's balanced output to drive long lines

INSTRUMENT PREAMP

The instrument input's 30 dB gain make it ideal for unbalanced, low-level, instrument sources. The SX201 is an ideal "front end" for a studio-grade instrument preamp



THE SX201 EQ/PREAMP provides studio-quality equalization for line level balanced or unbalanced signals, as well as for low level unbalanced signals. Three fully parametric bands of equalization are provided, with +15 dB boost and -30 dB cut capability, allowing the SX201 to be used for both creative and corrective equalization. Overlapping frequency controls cover the entire audio range, from 16 Hz to 20 kHz. Bandwidth is continuously variable from .05 octaves (for deep notch filtering), to 3.3 octaves (for smooth tone shaping).

The separate line and preamp inputs allow the SX201 to handle nearly any signal level. The line level input provides both balanced or unbalanced terminations, while the preamp input is unbalanced. The line level input is intended for use with signals that have already passed through a preamplifier. The preamp input provides 30 dB gain, and is intended for use with low-level signals such as those from synthesizers, guitars, bass guitars, or electronic drums. An overall input level control allows setting internal signal levels to match the current boost/cut conditions.

Features

- Input levels to +14 dB Left/Right and Left + Right output
- Studio quality
- Three-band parametric equalizer with peak/notch characteristic
- Balanced line or instrument inputs
- Balanced and unbalanced outputs
- UL approved power supply

Optional SX200 Series Accessories:

- SC-2 Security Cover – security cover/filler pane
- PS-2 Power Supply – replacement power supply
- RM-2 Rack Mount – 19" rack mounting shelf

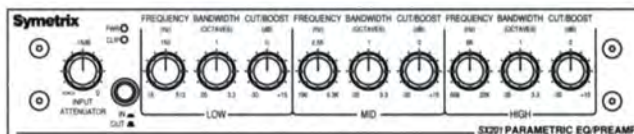

Specifications

Line Input	low-Z balanced/ unbalanced transformerless input impedance >20k	Frequency Response	20 Hz to 20 kHz, +0, -1 dB
Max Input Level	+18 dBu	THD+N	0.025%, 2 kHz, +18 dBm
Preamp Input	universal low-Z/high-Z unbalanced	S/N	101 dB @ full output
Input Impedance	>20k	Outputs	active balanced and unbalanced
Max Input Level	-12 dBu, 20 mV	Source Impedance	100 ohms, balanced 50 ohms, unbalanced
Parametric EQ	peak/notch curves	Maximum Output	+24 dBm, balanced +18 dBm, unbalanced
Boost/Cut	+15 dB, -30 dB	Power Requirements	16V ac, 200 ma (Symetrix PS-2 supplied)
Bandwidth	variable, 0.05 to 3.3 octaves	Accessories	RM-2 two-unit standard 19" rack mount
Frequency Range	16 Hz to 22 kHz, in 3 overlapping bands, 5 octave range/band	Physical	
Frequency Response	20 Hz to 20 kHz, +0, -1 dB	Size	1/2 rack unit
Band Ranges	Low: 16 to 512 Hz, Mid: 196 Hz to 6.3 kHz High: 686 Hz to 22 kHz	Size (HWD)	1.75 x 8.5 x 6.5 in

©1995 Symetrix, Inc. Specifications subject to change without notice.

SX SERIES

SX201

Symetrix

www.SteamPoweredRadio.Com

Symetrix Inc. • 14926 35th Ave. W. • Lynnwood, WA 98037 • USA • Tel: (206) 787-3222 • FAX: (206) 787-3211 • e-mail: 102102.1126@compuserve.com

551E Five Band Parametric EQ



Superior fidelity, flexibility, power, and precision. That's what sets the 551E Five Band Parametric Equalizer apart from the rest. Delivering an unbeatable combination of wide dynamic range, ultra-low distortion, minimal phase shift and ringing, easy to use controls, and rock-solid construction, the 551E is leap forward in equalizer technology.

The five, fully parametric EQ bands are identical in function. Each delivers up to 12 dB of boost and 20 dB of cut, has an adjustable bandwidth control (from .05 octaves to 2 octaves), and a frequency control range from 10 Hz to 20 kHz. Use each band anywhere in the audio spectrum, not just the pre-selected ranges you find on most equalizers. This can be very useful in sound system work, among other things. For instance, you can use three bands to correct low frequency problems and still have two bands left for midrange and high frequency work.

You'll find the 551E is just as useful for recording and broadcast applications. The wide control range allows you to perform creative as well as corrective equalization. Sweetening vocal tracks, getting that huge drum sound, disk mastering, or perfecting your radio station's signature sound are the kinds of tasks that are well within the 551E's capability.

As for sonic quality... Our proprietary UltraQ™ topology delivers extremely low noise audio performance - the kind you would normally expect only

from a much more expensive unit. We've also included a servo balanced output that completely removes all DC offset. Direct-coupled input and output stages maximize the 551E's low-frequency response while minimizing noise and distortion.

Inside and out, the 551E is designed to stand up to the worst road abuse. The tour-worthy all steel chassis houses a double-sided fiberglass circuit board - unlike the flimsy phenolic PCBs found in most budget priced units. Gold plated XLR connectors, a bypass relay, and high precision components ensure accuracy and reliability. Last, but not least, the 551E has an internal power supply with a detachable cord.

If you are an engineer in concert sound, installed systems, recording, or broadcast, contact your nearest Symetrix dealer today. See for yourself why the audiophile performance and uncompromising design of the 551E Five Band Parametric Equalizer make it the right choice for any professional audio application.

Features

- UltraQ topology delivers extremely low noise and distortion.
- Five identical, fully overlapping EQ bands.
- High cut and low cut filters.
- Servo balanced output (eliminates DC offset).
- Direct coupled inputs and outputs (superb low frequency response).
- Internal power supply with detachable cord.



If You Didn't Get This From My Site,
Then It Was Stolen From...

www.SteamPoweredRadio.Com

Applications

STUDIO RECORDING

MASTERING

SOUND SYSTEMS

Feedback suppression
Room tuning

RADIO AND TV BROADCAST

POST PRODUCTION SWEETENING

551E

Symetrix

551E Five Band Parametric EQ

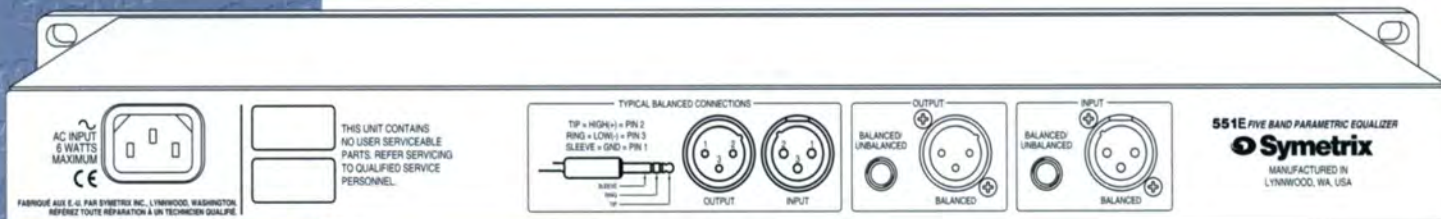

Specifications

Maximum input level	+21 dBu balanced	EQ band control specs:	
Maximum output level	+21 dBu balanced +17 dBu unbalanced	Frequency control range	10 Hz - 20 kHz (inc. Frequency Switch)
THD+Noise (1kHz at +4dBu)	<0.002%	Cut/Boost range	-20 dB, +12dB
	(<10 Hz to 30 kHz measurement bw)	Bandwidth	.05 oct - 2.0 oct
	-eq in, all bands flat	Chassis size	1.75"H x 19" W x 8" D 4.45cm H x 48.3cm W x 20.3cm D
Signal to noise ratio	>96 dB (unweighted, ref to +4dBu)	Shipping weight	8 lbs, 3.64 kg
	-eq in, all bands flat	AC Requirements	via internal supply 117V ac, nominal, 95-130V ac, 50-60 Hz 230V ac, nominal, 165-255V ac, 50 Hz
Dynamic range	>114 dB	Power Consumption	15 watts, maximum
Frequency Response	-0.5 dB, -3dB (20Hz - 62 kHz)	In the interest of continuous product improvement, Symetrix, Inc. reserves the right to alter, change, or modify these specifications without prior notice. Copyright, 1996, Symetrix, Inc. All rights reserved.	
Input impedance	10k ohms balanced, 5k ohms unbal.		
Output impedance	600 ohms balanced, 300 ohms unbal.		

Architects and Engineers Specifications

The parametric Equalizer (EQ) shall be a single channel unit that shall provide five independent filter bands. There shall also be separate highpass and lowpass filters. The unit shall occupy one rack space (1U).

Each filter band shall have the following controls and control ranges: a cut/boost control with a -20 dB - +12dB range, a frequency sweep control with a 100 Hz - 2kHz range, a frequency range multiplier switch with X10, X1, and 0.1 settings, and a bandwidth control with a .05 octave - 2.0 octave range. There shall also be a 12 dB/Oct highpass filter with a user adjustable cutoff frequency range 6Hz to 260 Hz, and a 12 dB/Oct lowpass filter with a cutoff frequency range from 3kHz to 65 kHz. A front panel input level control shall provide ± 15 dB of gain adjustment.

When the unit is inoperative (either by loss of power or via the BYPASS switch), the inputs and outputs will be wired together by a relay.

The frequency response with all filter bands flat, EQ in, highpass and lowpass set to the outside extremes of their ranges shall be 20Hz - 62 kHz (-0.5, -3dB). The total harmonic distortion plus noise shall be less than 0.002% (EQ in, all bands flat). The dynamic range shall be greater than

114 dB. The EQ shall accept a maximum input signal of +21 dBu and have a maximum output level of greater than +21 dBu. There shall be a front panel clip indicator that will illuminate at 1dB below clipping. It shall monitor the input, output and each EQ band.

The inputs shall be direct coupled, active balanced designs terminated with 3-pin XLR (AES/IEC standard wiring), and TRS female. The input circuitry shall incorporate RFI filters. There shall be a servo-balanced, direct-coupled output that shall terminate in 3-pin XLR (AES/IEC standard wiring) and TRS.

The EQ shall be capable of operating by means of its built-in power supply connected to 117V nominal AC, 105-130V, 50-60 Hz (230V nominal AC, 207-253V, 50 Hz where applicable). Power consumption shall be 15 watts maximum. There shall be a rear panel receptacle for an IEC type detachable power cord. The EQ shall be UL and CE approved.

The unit shall be a Symetrix Incorporated model 551E Five Band Parametric Equalizer.

551E

Symetrix

1996 Suggested Retail Price List
Effective September 1, 1996

Retail Price List



Symetrix 1996 Retail Price List

600 SERIES

610	Broadcast Audio Delay	\$2695
620	20 Bit A/D Converter	\$995

500 SERIES

572	SPL Computer (speaker sensing)	\$699
571	SPL Computer (mic sensing)	\$849
571S	SPL Computer Slave	\$349
551E	Five Band Parametric EQ	\$449 <i>New Product!</i>
528E	Voice Processor	\$699
501	Peak-RMS Compressor/Limiter	\$379
501-01	Peak-RMS Compressor	\$419

400 SERIES

488	DYNA-Squeeze™	\$579
450	Dual Zone Priority Mixer	\$629
425	Dual Compressor/Limiter/Expander	\$579
422	Stereo AGC-Leveler	\$595
421m	AGC-Leveler	\$569
420	Stereo Power Amplifier	\$399
402	Dual Output Delay	\$729

SX200 SERIES

SX204	Headphone Amplifier	\$319
SX202	Dual Mic/Preamplifier	\$319

ACCESSORIES

USC-1	Universal Security Cover	\$30
SC-2	Security Cover	\$30
PS-2	Power Supply	\$20
RM-2	Rack Mount	\$39

All prices subject to change without notice. ©1996 Symetrix, Inc. Effective September 1, 1996.

If You Didn't Get This From My Site,
Then It Was Stolen From...

www.SteamPoweredRadio.Com

International Distributors

Country	City	Company	Telephone	FAX
ARGENTINA	Buenos Aires	Mannys Music Center	541 3830224	541 3817868
AUSTRALIA	Ermington, NSW	Audio Telex Communications Pty	02 6471411	02 7482537
AUSTRIA	Winkel	A TEC Audio Technology GmbH	02234 74004	02234 74074
BELGIUM	Brussels	ASC Audio Systems Consultants	02 5200827	02 5211977
BRAZIL	Sao Paulo	Made In Brazil	18512848	18515008
CANADA	St. Laurent	SF Marketing	514 8561919	514 8561920
CENTRAL AMERICA	Guatemala	Inresa, S.A.	2530374	2530956
CHILE	Santiago	Audio JBL Chile Ltda.	562 223 4310	562 225 4116
CROATIA	Zagreb	Audio Design	1 265666	1 265665
CZECH REPUBLIC	Prague	Praha Music Center s.r.o.	224 810970	224 810159
DENMARK	Silkeborg	Dansk Tele Kommunikation	86810911	86814347
FINLAND	Espoo	Studiotec Finland	0592055	0592090
FRANCE	Paris	Cineco	149446015	143001538
GERMANY	Ibbenbueren	TRIUS	05451 94080	05451 78049
GREECE	Athens	Bon Studio S.A.	01 3609605	01 3645755
HOLLAND	Amsterdam	Iemke Roos Audio B.V.	0206 972121	0206 974201
HONG KONG	Kowloon	Audio Consultants Co. Ltd.	23513628	23513329
INDONESIA	Jakarta	Multi Audio Pro	021 6296009	021 6298453
ISRAEL	Kiron	Tech Top	35353762	36350445
ITALY	Bologna	Entel s.r.l.	051 768576	051 768336
JAPAN	Tokyo	TOWA	4041253	4041324
KOREA	Seoul	Young Nak So Ri Sa	02 2679697	02 2742611
LEBANON	Beirut	Fidelio Sound & Vision House	01 332899	01 602550
NEW ZEALAND	Hamilton	Audio & Video Wholesalers	07 8473414	07 8473412
NORWAY	Sofiemyr	Scandec Systems A/S	066805960	066805959
PHILIPPINES	Manila	Audiophile Components, Inc.	2583032	28187577
POLAND	Lomianki	Europe Sound Systems	27513146	39121239
RUSSIA	Moscow	AT Trade Music	095 9782016	095 9561105
SAUDI ARABIA	Jeddah	Halwani Audio	026691252	038992783
SINGAPORE	Singapore	Electronics & Engineering Pte.	65 2235873	65 2253709
SLOVENIA	Ljubljana	Nova	609620933	612632260
SPAIN	Barcelona	Pro 3	34735818	34732635
SWEDEN	Solna	Tal & Ton Studioteknik	08734075	08824476
SWITZERLAND	Zurich	Dr. W.A. Günther	019104141	019103544
SOUTH AFRICA	Johannesburg	Eltron (Pty) Ltd.	0117870355	0117879627
TAIWAN	Taipei	Sea Power Co., Ltd.	22982688	22982396
THAILAND	Bangkok	Amek/ Tac Thailand	23732722	23732722
TURKEY	Istanbul	Nefan Ticaret Ve Sanayi Ltd.	212 2604514	212 2602309
UNITED KINGDOM	Walton-on-Thames	Fuzion PLC	01932 882222	01932 882244
VENEZUELA	Caracas	Sonex De Venezuela C.A.	22395743	22391607

International Representatives

Location	Country	Company	Telephone	FAX
EUROPE	England	World Marketing Ltd.	01637 877170	01637 850495

Please note: The above listed telephone and fax numbers are given in the international format (as they would be dialed from inside the country).

United States Representatives

Company	Telephone	FAX	Location
Aldridge Marketing	(713) 528-2005	(713) 528-1239	TX, LA, OK, AR
Applied Audio Marketing, Inc.	(704) 252-9313	(704) 252-9332	GA, NC, SC, TN, AL, MS
Audio Associates	(410) 964-1212	(410) 964-0328	MD, DE, DC, VA, PA, WV
Cambridge Marketing Group	(614) 363-9191	(614) 363-1085	OH
Darmstedter Associates Inc	(315) 638-1261	(315) 638-1268	NY (upstate)
Derek Allen Associates	(818) 840-8327	(818) 843-6919	South CA, AZ, HI, South NV
JAMM Distributing	(708) 799-0550	(708) 799-0418	MI, IL, IN, WI, MN, KY
Loppnow & Associates	(206) 392-3936	(206) 392-3973	WA, OR, West ID, West MT, AK
Michael Chafee Enterprises	(813) 921-4294	(813) 923-7944	FL
On The Road Marketing	(201) 389-1718	(201) 389-1917	NY, CT, MA, ME, VT, NH, NJ, RI
Pro Tech Marketing Inc.	(801) 561-8844	(801) 561-9969	CO, UT, WY, NM, East ID, East MT
Jim Sherry Marketing	(913) 677-1013	(913) 677-2713	KS, NE, MO, ND, SD, IA
Trankle & Associates	(415) 595-4004	(415) 595-0292	North CA, North NV

Symetrix
 Audio
 Distribution
 Specialists



14926 35th Avenue West

Lynnwood, WA 98037 USA

Tel: (206) 787-3222

Fax: (206) 787-3211



If You Didn't Get This From My Site,
Then It Was Stolen From...

www.SteamPoweredRadio.Com