

**SHALLCO LADDER ATTENUATOR  
MODEL: 720Q-2A3-10K  
P/N A295**

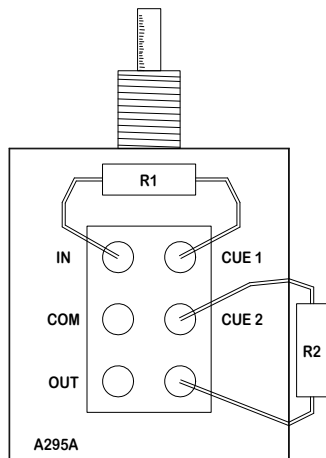

R1 & R2 = 4K7

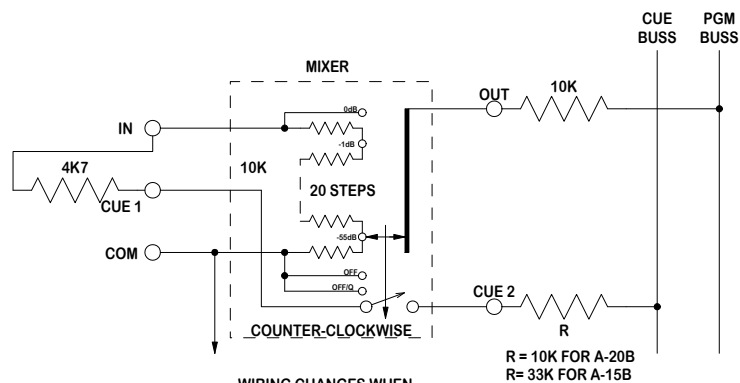

WIRING CHANGES WHEN STEPPING MIXERS ARE USED INSTEAD OF COMPOSITION TYPE

UPDATED MARCH 28, 2020 DRW

NOTE 1: CORRECTED LADDER RESISTOR VALUES.

NOTE 2: CORRECTED WIRING DIAGRAM FOR CHANGING FROM CARBON POTS TO LADDER ATTENUATORS.

NOTE 3: CORRECTED ATTENUATOR SIDE VIEW CONNECTIONS.

NOTE 4: ADDED BOTTOM VIEW OF ATTENUATOR PAD AND RING LOCATIONS AND INTERNAL CONSTRUCTION OF ATTENUATOR.

DRAWN: DAVID WIGFIELD 5/5/2018 REVISED 26 JAN 71

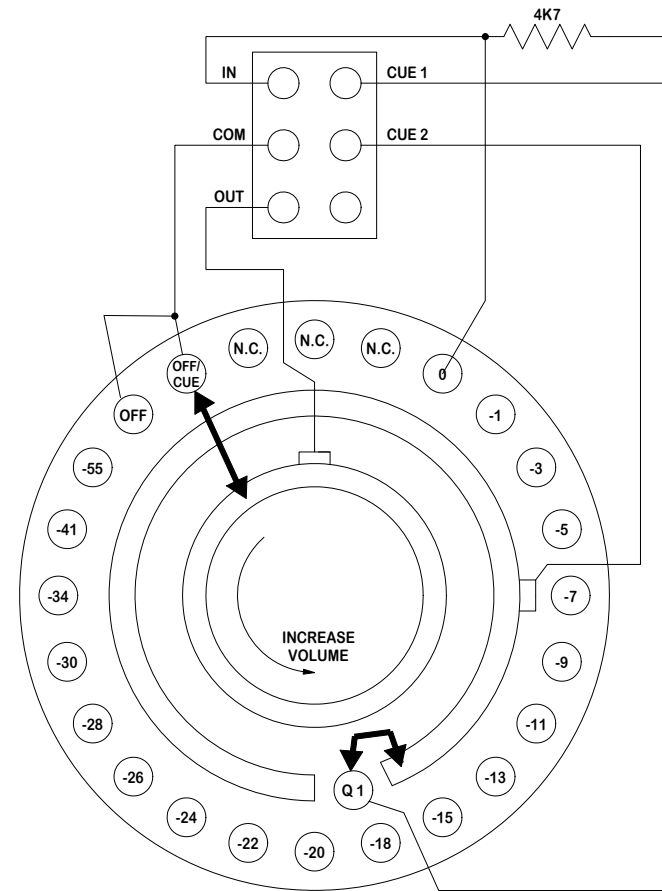

INTERNAL CONSTRUCTION OF FADER AS VIEWED FROM BOTTOM SHOWING WIPERS, IN HEAVY BLACK, AND WIPER RINGS. WIPERS ARE SHOWN IN THE CUE POSITION.

If You Didn't Get This From My Site,  
Then It Was Stolen From...  
[www.SteamPoweredRadio.Com](http://www.SteamPoweredRadio.Com)



TITLE  
**SHALLCO 10K LADDER  
ATTENUATOR  
MONO**

DRAWN.B. SCUDDER DATE. 6-7-76

SHT OF  
1 1

DWG. NO.

P-52A

APPD. RAD DATE.