

SESCOM, INC. 1990

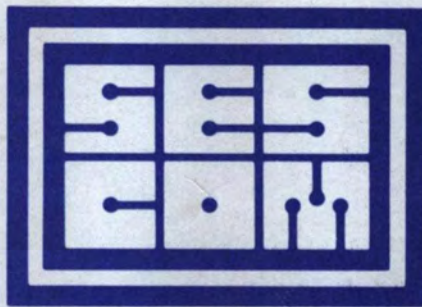

"the audio source"

2100 WARD DRIVE
HENDERSON, NV 89015-9998 U.S.A.



PHONE (702)565-3400

FAX (702)565-4828

TABLE OF CONTENTS

Welcome to our 1990 catalog, which has been expanded to 64 pages. We are continuing to expand our production capabilities with new equipment. This year we have added surface mounting equipment. During 1990 some of our products will change to surface mounted. At the same time we will be changing some of the internal circuitry to enhance its performance. If you are ever in the Las Vegas area and would like to visit our facility, you welcome to do so. Our plant hours are 8:00 A.M. to 4:00 P.M. Monday thru Friday. We have added four new Portables which will be found on page 58 of this catalog. This year we will be starting our twenty-third year of operations. This is all made possible by you our valued customers.

Sincerely yours,

SESCOM, Inc.

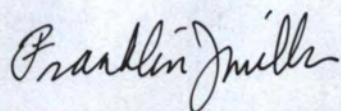

Franklin J. Miller

President

	PAGES
AUDIO SIGNAL PROCESSING	1-4
DIRECT BOX	30
MIC-LINE DRIVERS	12-15
MIC-SPLITTERS	24-29
MIXERS	8-11
MODULES	38-43
NEWSBRIDGE	4-7
SIGNAL PROCESSING	16-21
TEST EQUIPMENT	22-23
THE PORTABLES	44-58
TRANSFORMERS	31-37
TERMS & CONDITIONS	59
PRICE SHEET	60

AUDIO SIGNAL PROCESSING RACK SYSTEM



RK-RACK

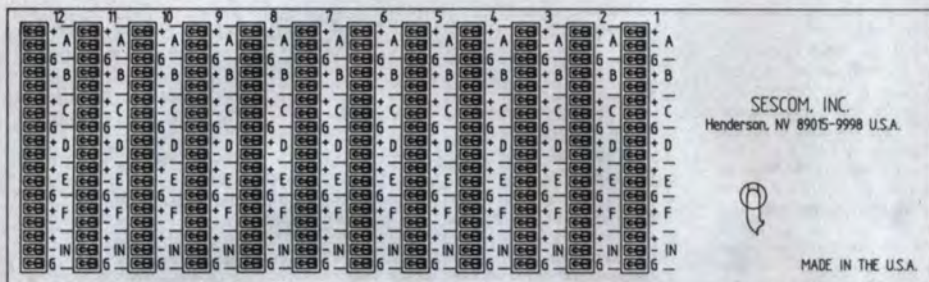

GENERAL: The RK-Rack is the housing assembly and power supply unit for the Sescom, Inc. RACK System. It contains one power supply unit and mounting rack assembly. It will accept twelve single units that plug-in to its pre-wired unit. The input and output connections are on the rear panel. These connections are screw terminals permanently mounted on the rear panel. The rear panel also houses the connection to line voltage (mains supply). All connections to the cards are made at the factory. There are no field connections to be made by the user. The input and output connections which are made by the user are simple screw terminals. The power supply which is supplied with rack housing, supplies plus and minus 21 volts DC unregulated. The supply is capable of 30VA under normal conditions. The unit is fused and has two indicators to tell if the supply is working.

AUDIO SIGNAL PROCESSING

The Audio Signal Processing system from Sescom was designed for versatility. Eleven different functional modules are currently available. The modules can be installed in any configuration and are powered by a single supply or dual redundant supplies. Physical height of the system is three rack mount spaces (5 1/4").

When configured with a single power supply up to twelve (12) single width modules can be installed in the system. On the rear panel of the system are screw terminal strips for the audio inputs and outputs. The terminals are permanently and clearly labeled. The single module is 1.20" wide and the dual module is 2.40" wide.

The power supply is a dual width unit and must be installed in one of the two left-most slots. The power supply modules are factory wired to use 115 VAC, 50/60 HZ, and can be configured for 230 VAC, 50/60 HZ by changing the position of board mounted jumpers. When set for 115 VAC the supply can also operate on 100 VAC, 50/60 HZ. A special toroidal power transformer is used in the module to minimize external hum fields.

All of the Audio Signal Processing modules are constructed from high quality components, specifically, low noise IC's, metal film resistors, low leakage capacitors and specially design audio transformers. These audio transformers are manufactured by Sescom. In addition, all of the metal work is fabricated in our modern metal working facility. The result of these extensive in-house capabilities is that Sescom can provide the customer with the best possible equipment at the lowest cost. The quality of these units is of the highest in the professional audio business making this system suitable for digital recording and playback. They feature ultra low distortion in (THD and IMD), low noise, and excellent sound quality. These units are designed for use in main broadcast systems and high quality recording environments. Final test of the modules are done on the computer controlled, Audio Precision, System One which enables Sescom to insure that the audio quality of the Audio Signal Processing systems are of the highest standards.

The first audio module is a line amplifier with one input and a single output. There are two distribution amplifiers with one input and six outputs. Both of these DA's feature transformer balanced inputs and outputs. One of the DA's has fixed gain and the other has six individual gain controls. A third Audio DA has one input and six isolated outputs with a ALC to control all of the outputs, a great solution for cable and satellite feeds.

There is an 8 watt power amplifier module that can be used as a monitor. It selects one of five inputs, has a front panel volume control and headphone jack. The rear panel has connections for hooking up a remote 4 or 8 ohm speaker.

There is a mic-line driver module that accepts two, balanced, low impedance, microphones and has two independent transformer balanced outputs. A switch on the board enables the phantom voltage.

The next module is a VCA remote controlled distribution amplifier. This unit has five transformer balanced outputs and a transformer balanced input. The remote gain pot or voltage is available on the rear terminals. There is a bypass switch on the front panel labeled VCA/Standby.

For the interfacing of semi-professional equipment to professional standards there is dual amplifier with unbalanced inputs and transformer balanced outputs. The unit is preset for 14 dB of gain but is adjustable. It also has two audio transformers and pad assembly that enable the unit to accept balanced +4 dBm inputs to unbalanced outputs at -10 dBv.

For use with satellite receivers or other devices that have varying gains the dual ALC is just the answer. This module will give a constant output level over its input range. No controls to ride. The last product in the line is a stereo phono pre-amp with transformer balanced outputs and a mono output.

RK-PS-1

GENERAL: The RK-PS-1 power supply is used in the SESCOM, Inc. RACK System as the second power supply for redundancy purpose. The unit has a special torodial power transformer for low external hum fields. The power supply circuit uses a heavy duty bridge rectifier and large electrolytic capacitors for filtering purpose. The unit is fused to protect the power transformer and has indicating LED's to inform the user that there is a problem. The RK-PS-1 supplies plus and minus 21 VDC unregulated. The unit also has steering diodes so that the two supplies can be on line simultaneously.

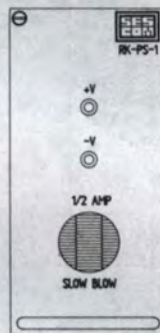

RK-PA

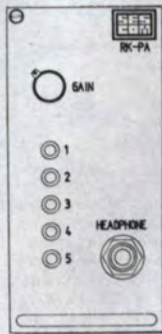

GENERAL: The RK-PA is five channel headphone/speaker amplifier. There is an input selector switch, which selects between any of the five inputs to the input transformer. The input circuitry has specially wound input transformer and magnetically shielded to prevent hum being induced into the electronic circuitry. The op-amps are low noise types and the resistors are precision metal-film types with low leakage capacitors. The special power amplifier IC drives 8 ohms loads with low distortion and broad frequency response. The power supply voltage comes into the unit and is regulated and filtered on the PC card to provide for the best possible performance. The units are final tested on a System One computer controlled tester, to assure compliance of all specifications. These units are built to the highest quality standards. They are designed for use in the most demanding applications.

INPUTS:
 TERMINAL STRIPS (five switchable)
INPUT IMPEDANCE:
 15K ohms balanced
MAX. INPUT LEVEL:
 +18dBv (line)
COM. -MODE REJECTION
 -87dB @ 1KHZ
 -76dB @ 10KHZ
NOISE:
 90dB Below Rated Output
FREQ. RESPONSE:
 +/-1dB, 20-20,000Hz

DISTORTION:
 (0.2% @ 20Hz Max. Rated Output
 (0.1% @ 30Hz Max. Rated Output
 (0.04% @ 50Hz Max. Rated Output
 (0.02% @ 1KHz Max. Rated Output
OUTPUT:
 TERMINAL STRIPS
OUTPUT LOAD:
 >8 ohms unbalanced
OUTPUT LEVEL:
 8 watts into 8 ohms
POWER REQUIREMENTS:
 PLUS AND MINUS 21 VOLTS DC
DIMENSION:
 60.96mm X 133.35mm X 209.55mm
 2.4" X 5.25" X 8.25"

RK-VCADA

GENERAL: The RK-VCADA is a audio distribution amplifier with a voltage control gain. There are five individual amplifiers and output transformers. The input circuitry has specially wound input transformer and magnetically shielded to prevent hum being induced into the electronic circuitry. The op-amps are low noise types and the resistors are precision metal-film types with low leakage capacitors. The power supply voltage comes into the unit and is regulated and filtered on the PC card to provide for the best possible performance. The units are final tested on a System One computer controlled tester, to assure compliance of all specifications. These units are built to the highest quality standards. They are designed for use in the most demanding applications.

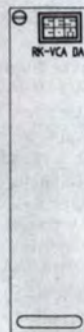

INPUTS:
 TERMINAL STRIPS
INPUT IMPEDANCE:
 15K ohms balanced
MAX. INPUT LEVEL:
 +18dBv (line)
COM. -MODE REJECTION
 -87dB @ 1KHZ
 -76dB @ 10KHZ
CONTROL:
 +20dB to -75dB
NOISE:
 90dB Below Rated Output
FREQ. RESPONSE:
 +/-1dB, 20-20,000Hz

DISTORTION:
 (0.2% @ 20Hz Max. Rated Output
 (0.1% @ 30Hz Max. Rated Output
 (0.04% @ 50Hz Max. Rated Output
 (0.02% @ 1KHz Max. Rated Output
OUTPUT:
 TERMINAL STRIPS
OUTPUT LOAD:
 >600 ohms Balanced (five outputs)
OUTPUT LEVEL:
 +18dBm Max.
POWER REQUIREMENTS:
 PLUS AND MINUS 21 VOLTS DC
DIMENSION:
 30.48mm X 133.35mm X 209.55mm
 1.2" X 5.25" X 8.25"

RK-MLD

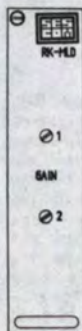

GENERAL: The RK-MLD is a dual Mic-Line driver. There are two individual amplifiers and input and output transformers. The input circuitry has specially wound input transformer and magnetically shielded to prevent hum being induced into the electronic circuitry. The op-amps are low noise types and the resistors are precision metal-film types with low leakage capacitors. There is a switch on the PC board to turn the phantom voltage on. The phantom voltage is 18 volts. The power supply voltage comes into the unit and is regulated and filtered on the PC card to provide for the best possible performance. The units are final tested on a System One computer controlled tester, to assure compliance of all specifications. These units are built to the highest quality standards. They are designed for use in the most demanding applications.

INPUTS:
 TERMINAL STRIPS
INPUT IMPEDANCE:
 150 ohms Balanced
MAX. INPUT LEVEL:
 -25dBv
COM. -MODE REJECTION
 -87dB @ 1KHZ
 -76dB @ 10KHZ
GAIN:
 +75dB to 41dB
NOISE:
 85dB Below Rated Output
FREQ. RESPONSE:
 +/-1dB, 20-20,000Hz

DISTORTION:
 (0.2% @ 20Hz Max. Rated Output
 (0.1% @ 30Hz Max. Rated Output
 (0.04% @ 50Hz Max. Rated Output
 (0.002% @ 1KHz Max. Rated Output
OUTPUT:
 TERMINAL STRIPS
OUTPUT LOAD:
 >600 ohms Balanced
OUTPUT LEVEL:
 +18dBm Max.
POWER REQUIREMENTS:
 PLUS AND MINUS 21 VOLTS DC
DIMENSION:
 30.48mm X 133.35mm X 209.55mm
 1.2" X 5.25" X 8.25"

RK-ALC

INPUTS:
 TERMINAL STRIPS
INPUT IMPEDANCE:
 15K ohms Balanced
MAX. INPUT LEVEL:
 +12dBv
COM. -MODE REJECTION
 -87dB @ 1KHZ
 -76dB @ 10KHZ
NOISE:
 85dB Below Rated Output
FREQ. RESPONSE:
 +/-1dB, 20-20,000Hz

DISTORTION:
 <0.2% @ 20Hz Max. Rated Output
 <0.2% @ 30Hz Max. Rated Output
 <0.2% @ 50Hz Max. Rated Output
 <0.2% @ 1kHz Max. Rated Output
OUTPUT:
 TERMINAL STRIPS
OUTPUT LOAD:
 >600 ohms Balanced
OUTPUT LEVEL:
 +18dBm Max.
POWER REQUIREMENTS:
 PLUS AND MINUS 21 VOLTS DC
DIMENSION:
 30.48mm X 133.35mm X 209.55mm
 1.2" X 5.25" X 8.25"

GENERAL: The RK-ALC is dual channel automatic level control line amplifier. There are two individual amplifiers with automatic gain control circuits mounted on the PC board, and input and output transformers, also level controls to set the output level. The input circuitry has specially wound input transformer and magnetically shielded to prevent hum being induced into the electronic circuitry. The op-amps are low noise types and the resistors are precision metal-film types with low leakage capacitors. The power supply voltage comes into the unit and is regulated and filtered on the PC card to provide for the best possible performance. The units are final tested on a System One computer controlled tester, to assure compliance of all specifications. These units are built to the highest quality standards. They are designed for use in the most demanding applications.



INPUTS:
 TERMINAL STRIPS
INPUT IMPEDANCE:
 15K ohms balanced
MAX. INPUT LEVEL:
 +18dBv (line)
COM. -MODE REJECTION
 -87dB @ 1KHZ
 -76dB @ 10KHZ
GAIN:
 +30dB to 0dB(each output)
NOISE:
 90dB Below Rated Output
FREQ. RESPONSE:
 +/-1dB, 20-20,000Hz

DISTORTION:
 <0.2% @ 20Hz Max. Rated Output
 <0.1% @ 30Hz Max. Rated Output
 <0.04% @ 50Hz Max. Rated Output
 <0.002% @ 1kHz Max. Rated Output
OUTPUT:
 TERMINAL STRIPS
OUTPUT LOAD:
 >600 ohms Balanced (six)
OUTPUT LEVEL:
 +18dBm Max.
POWER REQUIREMENTS:
 PLUS AND MINUS 21 VOLTS DC
DIMENSION:
 30.48mm X 133.35mm X 209.55mm
 1.2" X 5.25" X 8.25"

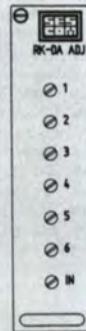

GENERAL: The RK-DAADJ is an audio distribution amplifier with adjustable gain controls on each amplifier. There are six individual amplifiers and output transformers. The input circuitry has specially wound input transformer and magnetically shielded to prevent hum being induced into the electronic circuitry, also there is an input gain control. The op-amps are low noise types and the resistors are precision metal-film types with low leakage capacitors. The power supply voltage comes into the unit and is regulated and filtered on the PC card to provide for the best possible performance. The units are final tested on a System One computer controlled tester, to assure compliance of all specifications. These units are built to the highest quality standards. They are designed for use in the most demanding applications.

RK-DA ADJ

INPUTS:
 TERMINAL STRIPS
INPUT IMPEDANCE:
 15K ohms balanced
MAX. INPUT LEVEL:
 +18dBv (line)
COM. -MODE REJECTION
 -87dB @ 1KHZ
 -76dB @ 10KHZ
GAIN:
 +30dB to 0dB(automatic gain)
NOISE:
 90dB Below Rated Output
FREQ. RESPONSE:
 +/-1dB, 20-20,000Hz

DISTORTION:
 <0.2% @ 20Hz Max. Rated Output
 <0.1% @ 30Hz Max. Rated Output
 <0.04% @ 50Hz Max. Rated Output
 <0.002% @ 1kHz Max. Rated Output
OUTPUT:
 TERMINAL STRIPS
OUTPUT LOAD:
 >600 ohms Balanced (six)
OUTPUT LEVEL:
 +18dBm Max.
POWER REQUIREMENTS:
 PLUS AND MINUS 21 VOLTS DC
DIMENSION:
 30.48mm X 133.35mm X 209.55mm
 1.2" X 5.25" X 8.25"

GENERAL: The RK-AGDA is an audio distribution amplifier with automatic gain control. There are six individual amplifiers and output transformers. The input circuitry has specially wound input transformer and magnetically shielded to prevent hum being induced into the electronic circuitry. The op-amps are low noise types and the resistors are precision metal-film types with low leakage capacitors. The power supply voltage comes into the unit and is regulated and filtered on the PC card to provide for the best possible performance. The units are final tested on a System One computer controlled tester, to assure compliance of all specifications. These units are built to the highest quality standards. They are designed for use in the most demanding applications.

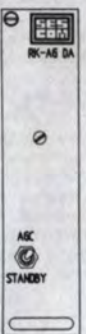

RK-AGDA

INPUTS:
 TERMINAL STRIPS
INPUT IMPEDANCE:
 15K ohms balanced
MAX. INPUT LEVEL:
 +18dBv (line)
COM. -MODE REJECTION
 -87dB @ 1KHZ
 -76dB @ 10KHZ
GAIN:
 +30dB to 0dB
NOISE:
 90dB Below Rated Output
FREQ. RESPONSE:
 +/-1dB, 20-20,000Hz

DISTORTION:
 <0.2% @ 20Hz Max. Rated Output
 <0.1% @ 30Hz Max. Rated Output
 <0.04% @ 50Hz Max. Rated Output
 <0.002% @ 1kHz Max. Rated Output
OUTPUT:
 TERMINAL STRIPS
OUTPUT LOAD:
 >600 ohms Balanced
OUTPUT LEVEL:
 +18dBm Max.
POWER REQUIREMENTS:
 PLUS AND MINUS 21 VOLTS DC
DIMENSION:
 30.48mm X 133.35mm X 209.55mm
 1.2" X 5.25" X 8.25"

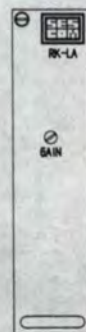

GENERAL: The RK-LA is a single channel line amplifier. There is an individual amplifier with adjustable gain control mounted on the PC board, and input and output transformers. The input circuitry has specially wound input transformer and magnetically shielded to prevent hum being induced into the electronic circuitry. The op-amps are low noise types and the resistors are precision metal-film types with low leakage capacitors. The power supply voltage comes into the unit and is regulated and filtered on the PC card to provide for the best possible performance. The units are final tested on a System One computer controlled tester, to assure compliance of all specifications. These units are built to the highest quality standards. They are designed for use in the most demanding applications.

RK-LA

RK-DA

GENERAL: The RK-DA is a audio distribution amplifier with fixed gain. There are six individual amplifiers and output transformers. The input circuitry has specially wound input transformer and magnetically shielded to prevent hum being induced into the electronic circuitry. The op-amps are low noise types and the resistors are precision metal-film types with low leakage capacitors. The power supply voltage comes into the unit and is regulated and filtered on the PC card to provide for the best possible performance. The units are final tested on a System One computer controlled tester, to assure compliance of all specifications. They are designed for use in the most demanding applications.

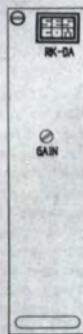

INPUTS:
 TERMINAL STRIPS
INPUT IMPEDANCE:
 15K ohms balanced
MAX. INPUT LEVEL:
 +18dBv (line)
COM. -MODE REJECTION
 -87dB @ 1KHZ
 -76dB @ 10KHZ
GAIN:
 +30dB to 0dB
NOISE:
 90dB Below Rated Output
FREQ. RESPONSE:
 +/-1dB, 20-20,000Hz

DISTORTION:
 <0.2% @ 20Hz Max. Rated Output
 <0.1% @ 30Hz Max. Rated Output
 <0.04% @ 50Hz Max. Rated Output
 <0.002% @ 1kHz Max. Rated Output
OUTPUT:
 TERMINAL STRIPS
OUTPUT LOAD:
 >600 ohms Balanced (six)
OUTPUT LEVEL:
 +18dBm Max.
POWER REQUIREMENTS:
 PLUS AND MINUS 21 VOLTS DC
DIMENSION:
 30.48mm X 133.35mm X 209.55mm
 1.2" X 5.25" X 8.25"

RK-SB

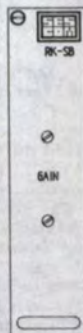

GENERAL: The RK-SB is dual channel adjustable line amplifier and two transformer with pads to convert balance to unbalance and reduce the level. There are two individual amplifiers with adjustable gain control mounted on the PC board, output transformers. The transformer section has specially wound input transformer and magnetically shielded to prevent hum being induced into the electronic circuitry. The op-amps are low noise types and the resistors are precision metal-film types with low leakage capacitors. The power supply voltage comes into the unit and is regulated and filtered on the PC card to provide for the best possible performance. The units are final tested on a System One computer controlled tester, to assure compliance of all specifications. These units are built to the highest quality standards. They are designed for use in the most demanding applications.

INPUTS:
 TERMINAL STRIPS
INPUT IMPEDANCE:
 100K ohms unbalanced (amplifier)
 600 ohms balanced (transformer)
MAX. INPUT LEVEL:
 +18dBv (amplifier)
 +18dBv (transformer)
COM. -MODE REJECTION
 -87dB @ 1KHZ
 -76dB @ 10KHZ
GAIN:
 +0dB to 30dB (amplifier)
 -14 dB (transformer)
NOISE:
 101dB Below Rated Output
FREQ. RESPONSE:
 +/-1dB, 20-20,000Hz

DISTORTION:
 <0.2% @ 20Hz Max. Rated Output
 <0.1% @ 30Hz Max. Rated Output
 <0.04% @ 50Hz Max. Rated Output
 <0.002% @ 1kHz Max. Rated Output
OUTPUT:
 TERMINAL STRIPS
OUTPUT LOAD:
 >600 ohms Balanced (amplifier)
 >600 ohms unbalanced (transformer)
OUTPUT LEVEL:
 +18dBm Max. (amplifier)
 +6dBm Max. (transformer)
POWER REQUIREMENTS:
 PLUS AND MINUS 21 VOLTS DC
DIMENSION:
 30.48mm X 133.35mm X 209.55mm
 1.2" X 5.25" X 8.25"

RK-SC

GENERAL: The RK-SC is dual channel phono pre-amp and line amplifiers with transformer outputs. There is also a line amplifier that has a mono combine with transformer output. The op-amps are low noise types and the resistors are precision metal-film types with low leakage capacitors. The power supply voltage comes into the unit and is regulated and filtered on the PC card to provide for the best possible performance. The units are final tested on a System One computer controlled tester, to assure compliance of all specifications. These units are built to the highest quality standards. They are designed for use in the most demanding applications.

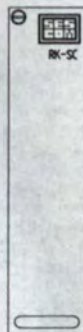

INPUTS:
 TERMINAL STRIPS
INPUT IMPEDANCE:
 47K ohms unbalanced (phono)
 15K ohms balanced (line)
MAX. INPUT LEVEL:
 -25dBv (phono)
 +18dBv (line)
COM. -MODE REJECTION
 -87dB @ 1KHZ
 -76dB @ 10KHZ
GAIN:
 +54dB (phono)
 0dB (line)
NOISE:
 90dB Below Rated Output
FREQ. RESPONSE:
 +/-1dB, 20-20,000Hz

DISTORTION:
 <0.2% @ 20Hz Max. Rated Output
 <0.1% @ 30Hz Max. Rated Output
 <0.04% @ 50Hz Max. Rated Output
 <0.002% @ 1kHz Max. Rated Output
OUTPUT:
 TERMINAL STRIPS
OUTPUT LOAD:
 >600 ohms Balanced (A & B output)
 >600 ohms Balanced (mono output)
OUTPUT LEVEL:
 +18dBm Max. (A & B output)
 +18dBm Max. (mono output)
POWER REQUIREMENTS:
 PLUS AND MINUS 21 VOLTS DC
DIMENSION:
 30.48mm X 133.35mm X 209.55mm
 1.2" X 5.25" X 8.25"

RK-LP

RK-SP

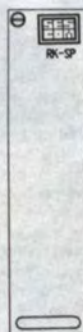

GENERAL: The RK-SP and RK-LP are blank panels to fill the unused space in the RK-RACK assembly. The RK-SP is 1.2" wide and the RK-LP is 2.4" wide. They make the unit have the finished look. They also prevent people from putting their hands inside the active electronics a safety factor.

**MODEL: MB-2****FIELD NEWSBRIDGE**

MB-2 is designed as a complete mixer and news bridge in one compact package. It is ideally suited for press conferences, remote news coverage and almost any application requiring multiple isolated microphone feeds. The MB-3 is a fine accessory to expand the usefulness of the MB-2. It will add twelve line level outputs.

The MB-2 is a field proven device. It has been in the field for over ten years. There are several hundred units in field service proving themselves in daily use. They are ruggedly constructed for field use.

There are three input channels, two of which are transformer-balanced microphone inputs and the third is a balanced bridging line level input. In addition, the microphone inputs have low cut filters, and a summing input is also provided for connecting the output of a second mixer to the summing bus.

In the output section, a master level control permits control of the 24 microphone level outputs. There is a headphone amplifier with a level control and two jacks wired for stereo type headphones, 1/4" and 3.5mm types. A pre-master, balanced, line level output is also provided for feeding a sound reinforcement system or the summing input of another MB-2, MB-1 and an MB-3. The mult outputs are comprised of 12 male XLR type balanced outputs and 12 mini phone jack type unbalanced outputs. The 12 mini phone jacks are isolated from the chassis to prevent common ground problems. All 24 outputs are transformer isolated with individual Faraday shields and an output impedance of 150 ohms. For further isolation, a 40 dB pad is between the transformer secondary and the output connector. This pad arrangement leads to 80 dB of isolation between any two outputs. The mult output section may be connected by using the looping inputs and outputs to another MB-2, MB-1 and MB-3 for additional mult outputs.

The VU meter is post-master and has a driver stage to isolate it from the output bus.

The MB-2 has a flow diagram on the underside of the unit describing the operation of the unit. It shows how to connect the unit in a system with one or more units. It also describes how to use the other jacks in a system.

The unit can be powered by its four internal 9 volt alkaline batteries (not supplied), mounted on the left hand side of the unit which are housed in slide-lock housings (no tools required for battery changes), or its internal AC supply using a toroidal power transformer for low hum field.

To obtain a complete owners manual simply request it from the factory before you purchase the unit.

SPECIFICATIONS:

INPUT:

Bridging Transformer, Female XLR (mic & line)

Phone Jack (summing) & (looping)

INPUT IMPEDANCE:

10K ohms Balanced (line)

150 ohms Balanced (mic)

47K ohms Unbalanced (summing)

100K ohms Unbalanced (looping)

MAX. INPUT LEVEL:

-36dBv (mic)

+18 dBv (line)

+18 dBv (summing)

+18 dBv (looping)

GAIN:

Unity (mic)

-50dB (line)

NOISE:

-90dB below Rated Output

FREQ. RESPONSE:

+/-1dB, 20-20K Hz

DISTORTION:

<0.2% @ 20Hz Max. Output

OUTPUT:

Transformer Isolated With Individual Faraday Shields, 12 Male XLRs & 12 Mini Phone Jacks (mic) Floating Transformer Isolated, Male XLR (line)

OUTPUT LOAD:

>150 ohms Balanced (mic)

>600 ohms Balanced (line)

>10K ohms Unbalanced (looping)

OUTPUT LEVEL:

-34dBv Max. (mic)

+18dBm Max. (line)

+18dBm Max. (looping)

POWER REQUIREMENTS:

120VAC or 220VAC, 50/60Hz

Internal Selectable

Less Than 2 Watts

4 Nine Volt Alkaline Transistor Batteries

DIMENSION:

43.82cm X 18.42cm X 8.89cm

13.25" X 7.25" X 3.50"

MB-2
MULTIPLE SYSTEM DIAGRAM
&
INDIVIDUAL FLOW DIAGRAM

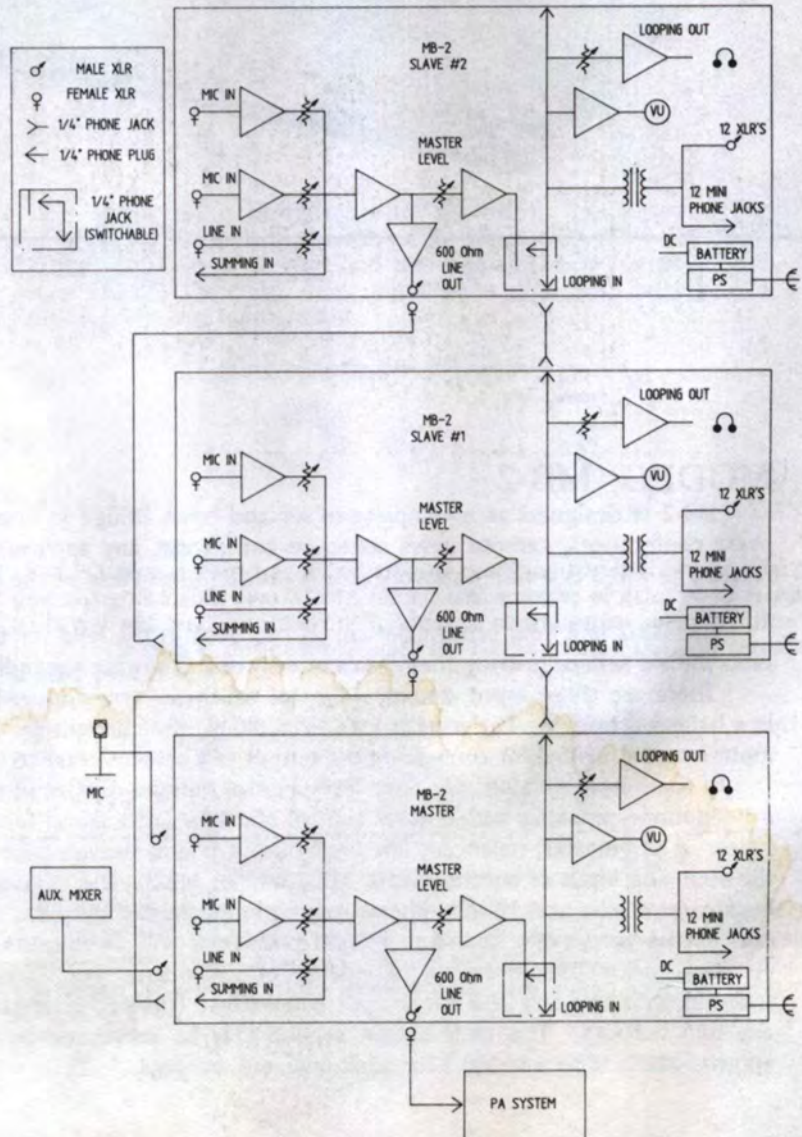

MODEL: MB-3 12-CHANNEL LINE LEVEL NEWSBRIDGE

The MB-3 is a companion box to the MB-2. It is a 12-channel line level news mult box. It will feed 12 line level pieces of equipment with +4 dBm transformer-balanced 600 ohms signal. Each output, which is a male XLR, has a separate output transformer and a buffer amplifier so that there is maximum isolation between outputs.

The MB-3 can be fed from the MB-2 Field Newsbridge or any +4 dBm source. There are no controls of the level. It must be used in conjunction with another device to control its level. Therefore it can be placed in the middle of the news core without any problems. It has a 15k ohm transformer bridging input with another +4 dBm transformer output to feed another MB-3 box. The MB-3 has a built-in headphone amplifier and buffered VU meter. Its power supply operates from 100-240 VAC 50/60 Hz or four nine volt transistor batteries (not supplied), preferably alkaline or Kodak lithium, which are enclosed in a slide-lock housing for easy access. The unit is constructed just like the MB-2.

SPECIFICATIONS:

INPUT: Bridging Transformer, Female XLR	FREQ. RESPONSE: +/-1dB 20-20,000Hz	POWER REQUIREMENTS: 120VAC or 220VAC, 50/60Hz Internal Selectable
INPUT IMPEDANCE: 10K ohms Balanced (line)	DISTORTION: <0.2% @ 20Hz Max. Output	Less Than 2 Watts
MAX. INPUT LEVEL: +18dBv (line)	OUTPUT: Transformer Isolated and buffered outputs, 12 Male XLRs	4 Nine volt alkaline transistor batteries
GAIN: Unity (line)	OUTPUT LOAD: >600 ohms Balanced (line)	DIMENSIONS: 43.18cm X 18.42cm X 8.89cm
NOISE: -90dB Below Rated Output	OUTPUT LEVEL: +18dBm Max. (line)	17.00" X 7.25" X 3.50"

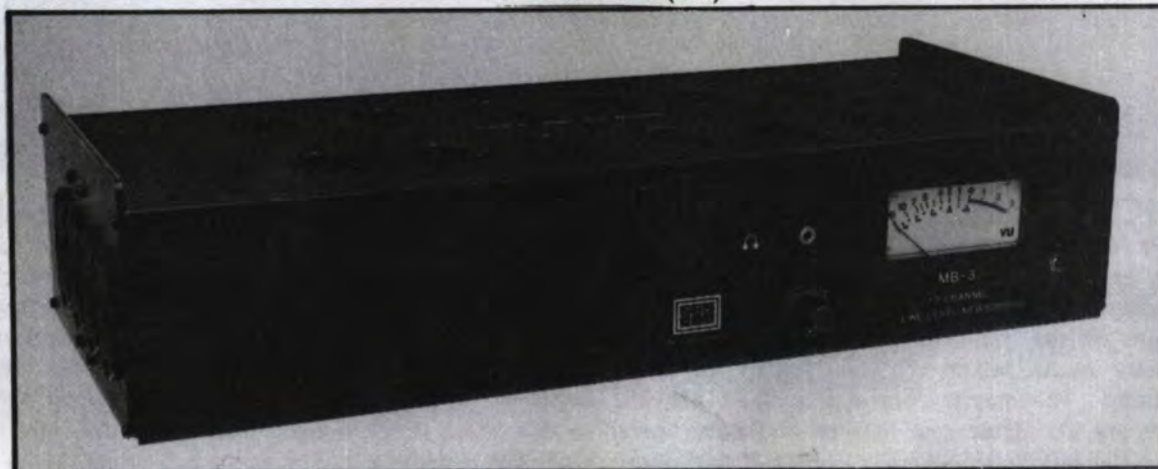

MODEL: MB-4

12--CHANNEL VIDEO DA

The MB-4 is a 12-channel Video DA. The unit is constructed in the same fashion as the MB-2 Field Newsbridge. These products are designed to work together in situations in which there is a common feed of the audio and video in a press conference. The MB-4 will handle the video portion. The unit will accept standard 1 volt signal 75 ohms. It also has a thru jack to pass the signal to another box or it can terminate the signal.

The MB-4 has amplification to overcome the losses when distributing the signal to multiple outputs. The outputs are divided into groups of four with amplifiers and current drivers to feed the 75 ohm outputs. The power supply, which is built-in, works from 100-240 VAC 50/60 Hz, and the MB-4 can be powered from four nine volt transistor batteries, preferably alkaline or Kodak lithium, which are enclosed a slide-lock housing for easy access.

SPECIFICATIONS:

INPUT: Bridging , BNC	NOISE: -90dB Below Rated Output	POWER REQUIREMENTS: 120 VAC or 220VAC Internal Selectable
INPUT IMPEDANCE: Bridging 10k ohms or 75 ohms, terminated	BANDWIDTH: 5.5 M Hz	Less Than 2 Watts
MAX. INPUT LEVEL: 2 volts P-P	OUTPUT: Resistor and buffered outputs, 12 BNC	4 Nine volt alkaline Transistor Batteries
GAIN: Unity	OUTPUT LOAD: >75 ohms unbalanced	DIMENSIONS: 33.65cm X 18.42cm X 8.89cm
	OUTPUT LEVEL: 1 volt P-P	13.25" X 7.25" X 3.50"



MODEL: MIX-1 4-CHANNEL STEREO MICROPHONE MIXER

MIX-1 is a four-channel line and microphone input mixer. The unit has pan-pots to assign each input to the right or left channel or anywhere in-between. Each input also has a gain pot to vary the gain from microphone level to line level. Each input has female XLR connectors and is transformer-balanced. The outputs of the pan-pots are actively summed by a virtual ground type amplifier which also includes the auxiliary inputs, which are then fed to the looping jacks where the units may be combined for greater flexibility. The master control then feeds the line amplifier stages for final transformer-balanced output. There are VU meter amplifiers to buffer the meter so that there is no induced distortion. The 1/4 watt stereo headphone amplifiers listen to the final output of the line amplifiers.

The power supply is a standard configuration full wave-bridge, comprised of large value capacitors, and three terminal regulators for both positive and negative voltages, and finally another large value capacitor for smoothing.

SPECIFICATIONS:

INPUT:

- 4 Female XLR (MIC/LINE)
- 2 RCA jacks (AUX)
- 1 1/4" stereo jack (looping)

INPUT IMPEDANCE

600 ohms Balanced

MAX. INPUT LEVEL:

+18dBv

GAIN

+80 dB

NOISE

101dB Below Rated Output

FREQ. RESPONSE:

+/-1dB, 20-20k Hz

DISTORTION:

<.2% @ 20Hz Max. Rated

OUTPUT:

- 2 Male XLRs
- 1 1/4" stereo jack (headphone)
- 1 1/4" stereo jack (looping)

OUTPUT LOAD:

>600 ohms Balanced

OUTPUT LEVEL:

+18dBm Max.

POWER REQUIREMENTS:

120VAC or 240VAC, 50/60Hz

Internal Selectable

DIMENSION:

26.0cm X 18.5cm X 3.3cm - 1.17cm

10.25" x 7.25" x 1.3" - 4.6"

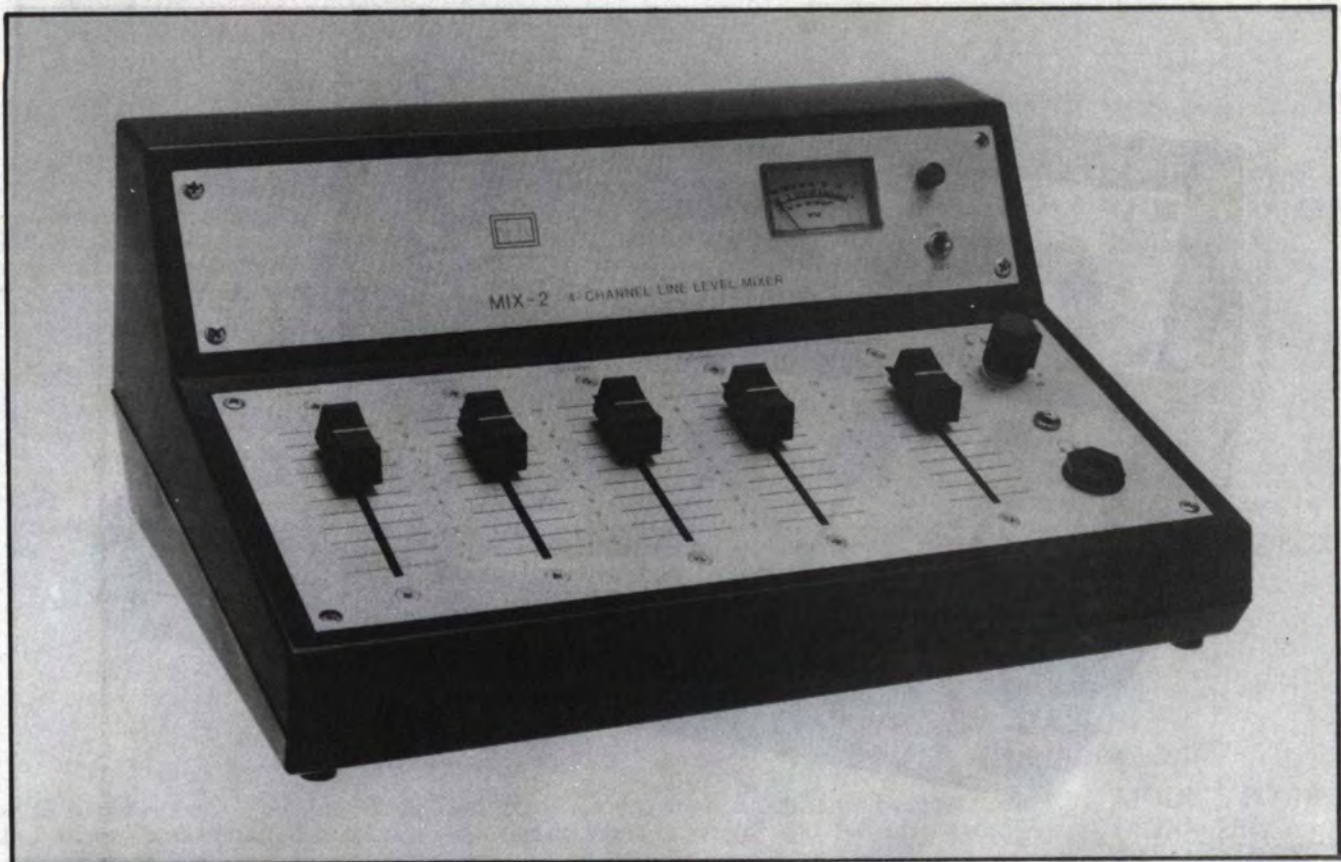

MODEL: MIX-2 4-CHANNEL LINE LEVEL MIXER

MIX-2 is four-channel line input mixer. All of the inputs have 1/4" mono phone jacks. The output of the level controls are actively summed by a virtual ground type amplifier which also includes the auxiliary input, which are then fed to the looping jack where the units may be combined for greater flexibility. The master control then feeds the line amplifier stage for final transformer-balanced output. There is a VU meter amplifier to buffer the meter so that there is no induced distortion. The 1/4 watt mono headphone amplifier listens to final output of the line amplifier.

The power supply is a standard configuration full wave-bridge, comprised of large value capacitors and three terminal regulators for both positive and negative voltages, and finally another large value capacitor for smoothing.

SPECIFICATIONS:

INPUT:

- 4 1/4" mono jacks (line)
- 1 RCA jacks (AUX)

- 1 1/4" mono jack (looping)

INPUT IMPEDANCE:

- 15K ohms unbalanced (line)

MAX. INPUT LEVEL:

- +18dBv (line) GAIN
- +30 dB NOISE

NOISE:

- 101dB Below Rated Output

FREQ. RESPONSE:

- +/-1dB, 20-20k Hz

DISTORTION:

- <.2% @ 20Hz Max. Rated Output

OUTPUT:

- 1 Male XLRs
- 1 1/4" mono jack (headpone)
- 1 1/4" mono jack (looping)

OUTPUT LOAD:

- >600 ohms Balanced

OUTPUT LEVEL:

- +18dBm Max.

POWER REQUIREMENTS:

- 120VAC or 240VAC, 50/60Hz
- Internal Selectable

DIMENSION:

- 26.0cm X 18.5cm X 3.3cm - 1.17cm
- 10.25" X 7.25" X 1.3" - 4.6"

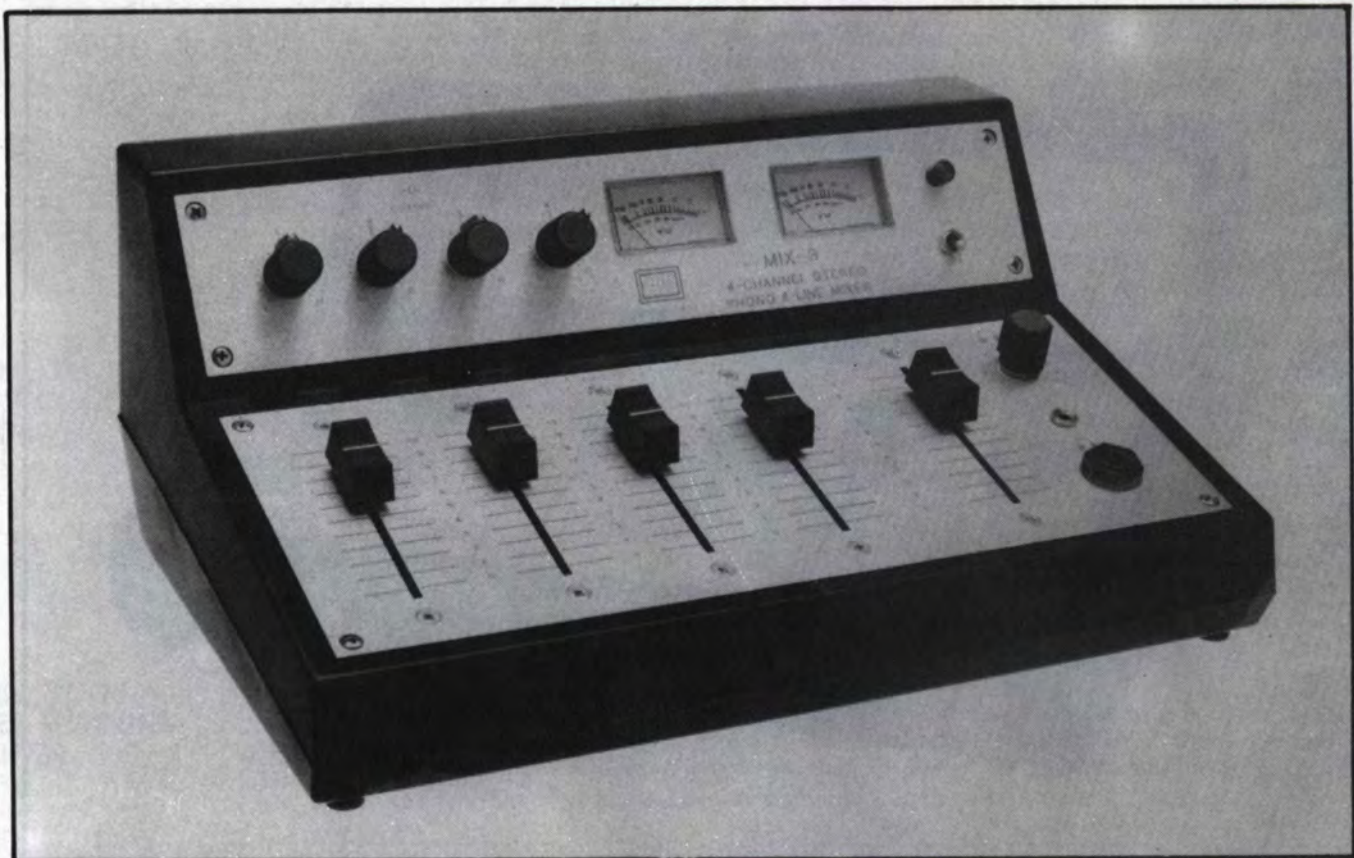

MODEL: MIX-3 4-CHANNEL STEREO PHONO & LINE MIXER

MIX-3 is a three-channel line and phono (RIAA) input mixer. The unit has pan-pots to assign each input to the right or left channel or anywhere inbetween. Three of the inputs are 1/4" stereo phone jacks. The fourth input has two RCA jacks for RIAA input. The outputs of the pan-pots are actively summed by a virtual ground type amplifier which also includes the auxiliary inputs, which are then fed to the looping jacks where the units may be combined for greater flexibility. The master control then feeds the line amplifier stage for final transformer-balanced outputs. There are VU meter amplifiers to buffer the meter so that there is no induced distortion. The 1/4 watt stereo headphone amplifiers listen to final output of the line amplifier.

The power supply is a standard configuration. It is comprised of a full wave-bridge, large value capacitors and three terminal regulators for both positive and negative voltages, and finally another large value capacitor for smoothing.

SPECIFICATIONS:

INPUT:

- 3 1/4" stereo jacks (line)
- 2 RCA Jacks (RIAA)
- 2 RCA jacks (AUX)
- 1 1/4" stereo jack (looping)

INPUT IMPEDANCE

- 15K ohms unbalanced (line)
- 47K ohms unbalance (RIAA)

MAX. INPUT LEVEL:

- +18dBv (line)
- 75 mv (RIAA)

GAIN

- +80 dB

NOISE

- 101dB Below Rated Output

FREQ. RESPONSE:

- +/-1dB, 20-20k Hz

DISTORTION:

- <.2% @ 20Hz Max. Rated Output

OUTPUT:

- 2 Male XLRs
- 1 1/4" stereo jack (headphone)
- 1 1/4" stereo jack (looping)

OUTPUT LOAD:

- >600 ohms Balanced

OUTPUT LEVEL:

- +18dBm Max.

POWER REQUIREMENTS:

- 120VAC or 240VAC, 50/60Hz
- Internal Selectable

DIMENSION:

- 26.0cm X 18.5cm X 3.3cm - 1.17cm
- 10.25" X 7.25" X 1.3" - 4.6"



MODEL: MIX-4 4-CHANNEL MICROPHONE & LINE MIXER

MIX-4 is a four-channel mono microphone and line input mixer. Each input has female XLR connectors and is transformer-balanced. Each input also has a gain pot to vary the gain from microphone level to line level. The outputs of the pre-amps are actively summed by a virtual ground type amplifier which also includes the auxiliary input, which are then fed to the looping jack where the units may be combined for greater flexibility. The master control then feeds the line amplifier stage for final transformer-balanced output. There is a VU meter amplifier to buffer the meter so that there is no induced distortion. The 1/4 watt stereo headphone amplifier listens to the final output of the line amplifier.

The power supply is a standard configuration full wave-bridge, comprised of large value capacitors, and three terminal regulators for both positive and negative voltages, and finally another large value capacitor for smoothing.

SPECIFICATIONS:

INPUT:

- 4 Female XLR
- 1 RCA jacks (AUX)
- 1 1/4" mono jack (looping)

INPUT IMPEDANCE:

600 ohms Balanced

MAX. INPUT LEVEL:

+18dBv

GAIN:

+80dB

NOISE:

101dB Below Rated Output

FREQ. RESPONSE:

+/-1dB, 20-20k Hz

DISTORTION:

<.2% @ 20Hz Max. Rated Output

OUTPUT:

- 1 Male XLRs
- 1 1/4" mono jack (headpone)
- 1 1/4" mono jack (looping)

OUTPUT LOAD:

>600 ohms Balanced OUTPUT LEVEL:
+18dBm Max.

POWER REQUIREMENTS:

120VAC or 240VAC, 50/60Hz
Internal Selectable

DIMENSION:

26.0cm X 18.5cm X 3.3cm - 1.17cm
10.25" X 7.25" X 1.3" - 4.6"

If You Didn't Get This From My Site,
Then It Was Stolen From...

MODEL:

MLD-1MKII / MLD-3

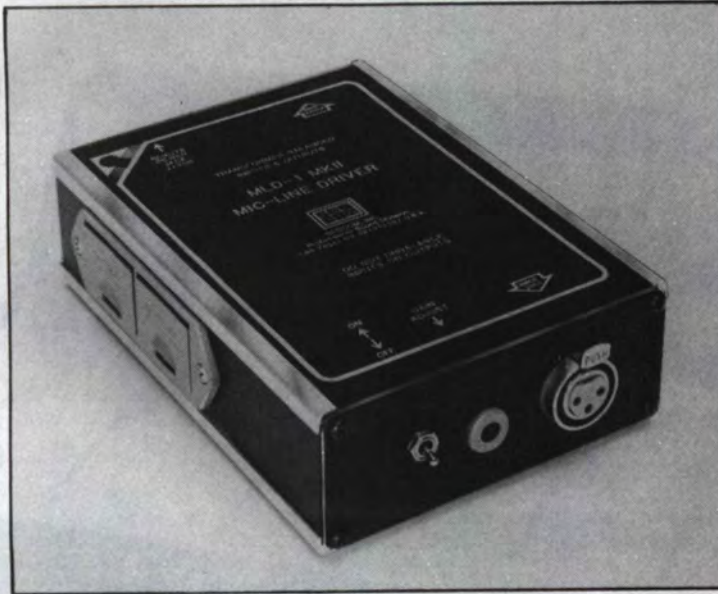

The MLD-1 and MLD-3 units feature two stages of amplification with maximum output of +16dBm and screwdriver adjustable gain from the front panel. The units are designed to be used for news, sports or live commercials from remote locations.

The transformer-balanced input will accept a low impedance dynamic or condenser microphone, and the unit can supply phantom power to the microphone.

The output is 600 ohms transformer-balanced. The MLD's are most useful when using extremely long or noisy mic-type cables or Telco pairs.

The MLD-3 is also provided with switches to activate the limiter circuit and to turn on the phantom power to the input connector.

The two (2) nine transistor batteries are included and are enclosed in a slide lock plastic housing (no tools required to change batteries).

SPECIFICATIONS

INPUT:

Transformer-Balanced, Female XLR

INPUT IMPEDANCE:

150 ohms Balanced

MAX. INPUT LEVEL:

-25dBv

GAIN:

+75 to +41dB (adjustable)

NOISE:

-80dB Below Rated Output

FREQ. RESPONSE:

+/-1dB, 20-20K Hz

DISTORTION:

< .20% @ 20Hz Max. Rated

Output

< .10% @ 30Hz Max. Rated

Output

< .04% @ 50Hz Max. Rated

Output

< .011% @ 1kHz Max. Rated

Output

OUTPUT:

Transformer-Balanced, Male XLR

OUTPUT LOAD:

> 600 ohms Balanced OUTPUT

LEVEL:

+16dBm Max.

POWER REQUIREMENTS:

Two 9V Batteries

Remote 24VDC Power Jack

Phantom Supply

DIMENSION:

15.50cm X 11.11cm X 4.57cm

6.125" X 4.375" X 1.80"



MIC-LINE DRIVERS

SPECIFICATIONS:

INPUT:
2 Female XLRs
INPUT IMPEDANCE:
150 ohms Balanced
MAX. INPUT LEVEL:
-29dBv
GAIN:
+30 dB adjustable
NOISE:
90dB Below Rated Output
FREQ. RESPONSE:
+/-i DB, 20-20kHz
BANDWIDTH:
45 kHz @ -3dB
DISTORTION:
(Max. Rated Output)
<0.2% @ 20Hz
<0.1% @ 30Hz
<0.5% @ 50Hz
<0.002% @ 1kHz
OUTPUT:
2 Male XLRs
OUTPUT LOAD:
>600 ohms Balanced
OUTPUT LEVEL:
+21dBm Max.
POWER REQUIREMENTS:
120 VAC or 220VAC, 50/60Hz
Internal Selectable
DIMENSION:
48.66 cm X 4.44 cm X 12.70 cm
19.00" X 1.75" X 5.00"

MODEL: MLD-7 MIC-LINE DRIVER

SPECIFICATIONS:

INPUT:
Transformer-Balanced, Female XLR
INPUT IMPEDANCE:
150 ohms Balanced
MAX. INPUT LEVEL:
-25dBv
GAIN:
+75 to +41dB (adjustable)
NOISE:
-80dB Below Rated Output
FREQ. RESPONSE:
+/-1dB, 20-20,000Hz
DISTORTION:
<.20% @ 20Hz Max. Rated Output
<.10% @ 30Hz Max. Rated Output
<.04% @ 50Hz Max. Rated Output
<.011% @ 1kHz Max. Rated Output
OUTPUT:
Transformer-Balanced, Male XLR
OUTPUT LOAD:
>600 ohms Balanced
OUTPUT LEVEL:
+16dBm Max.
POWER REQUIREMENTS:
Two 9V Batteries
110/220 VAC 50/60 Hz selectable
DIMENSION:
15.50cm X 11.11cm X 4.57cm
6.125" X 4.375" X 1.80"

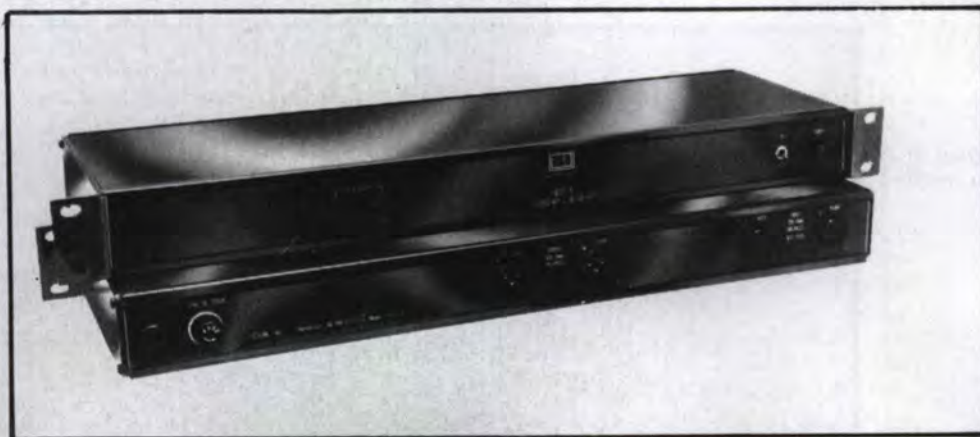

MODEL: MLD-6 DUAL MIC-LINE DRIVER

The MLD-6 is a rack-mountable dual mic-line driver for low impedance microphones to bring them to line level. The unit features transformer-balanced inputs and outputs with XLR type connectors. The gain of the amplifiers is front panel adjustable. The MLD-6 is one rack unit high and is AC powered.



The MLD-7 mic-line driver can be used with various power sources. The unit has two 9 volt batteries with slide-lock cases that require no tools to change them. It has a switch on the rear panel which changes it from 120 to 240 VAC 50/60 Hz. The unit can operate from as low as 100 VAC or as high as 240 VAC. The power cable is a detachable three-prong type, which is available almost anywhere in the world with the proper fitting on the other end.

The unit has a gain pot which is adjustable with a screwdriver thru a front panel hole. The MLD-7 can phantom power a microphone with a minimum of 18VDC to a maximum of 24VDC depending how the unit is powered. There is a front panel switch to turn the phantom power on or off. Also located on the panel is an on/off switch and an LED to indicate the unit is operating. The female XLR which is used for the input connector is also mounted on the front panel. The output male XLR connector and the ground lift switch are mounted on the rear panel. The AC power connector with built-in fuse holder with spare fuse (5 X mm type) are also on the same rear panel.

The MLD-7 has two audio transformers; the input transformer is a double shielded unit to prevent hum fields from entering the input stages when operated with AC power. The output transformer provides a balanced output plus isolation from other devices that it connects. The power supply circuit has a specially designed power transformer which has a single mu-metal shield to prevent AC hum fields from entering into the input circuitry. The power supply is regulated to provide a clean power source. The unit has 80 dB of gain available of which 30 dB are adjustable. The MLD-7 uses a low noise dual op-amp to achieve its specifications.

The unit is housed in a specially designed aluminum housing, which is black anodized with all the nomenclature silk screened on the metal. On the bottom of the unit there is a flow diagram.



MODEL: MLD-8 MIC LINE DRIVER W/ HEADPHONE MODEL: MLD-9

The MLD-8 and MLD-9 are mic-line drivers with built-in headphone amplifiers. They are designed to be used with boom microphones or parabolic microphones so that the operator of the microphone can hear what is being sent down the line.

The MLD-8 can phantom power the microphone and the MLD-9 has A-B power for the microphone. Both units operate from two 9 volt batteries which are housed in slide-lock battery cases that require no tools for battery change. The MLD-8 and MLD-9 have heavy-duty belt clips which are field removable. The headphone amplifier can deliver a 1/4 watt into 8 ohms.

The units have a volume control and 1/4" stereo jack wired for mono signal on the front panel. Also located on the front panel is the on/off switch. On the rear panel are both input and output XLRs for the microphone input and line output. On the top panel there is a flow diagram on how the MLD-8 and MLD-9 function. The unit is constructed of black anodized aluminum panels and extrusion. The MLD-8 and MLD-9 have two audio transformers; the input transformer is a double shielded unit to prevent hum fields from entering the input stages when operated near AC hum fields. The output transformer provides a balanced output plus isolation from other devices that it connects. The units have 80 dB of gain available of which 30 dB are adjustable. The units use a low noise dual op-amp to achieve their specifications. The headphone amplifier will deliver 1/4 watt into 8 ohms.

SPECIFICATIONS:

INPUT:

Transformer-Balanced, Female XLR

INPUT IMPEDANCE:

150 ohms Balanced

MAX. INPUT LEVEL:

-25dBv

GAIN:

+75 to +41dB (adjustable)

HEADPHONE AMPLIFIER:

1/4 watt

HEADPHONE JACKS:

1/4 jack stereo
wired mono

NOISE:

-80dB Below Rated Output

FREQ. RESPONSE:

+/-1dB, 20-20K Hz

BANDWIDTH:

45kHz @ -3dB

RISE TIME:

5uS (10%-90%)

DISTORTION:

<.20% @ 20Hz Max. Rated Output

<.10% @ 30Hz Max. Rated Output

<.04% @ 50Hz Max. Rated Output

<.11% @ 1kHz Max. Rated Output

OUTPUT LOAD:

>600 ohms Balanced

>8 ohms (headphones)

OUTPUT LEVEL:

+16dBm Max.

1/4 watt (headphone)

POWER REQUIREMENTS:

Two 9V Batteries

(DC-DC converters)

POWER REQUIREMENTS FOR MICROPHONES:

MLD-8 48 volts phantom

MLD-9 12 volts AB power

DIMENSION:

15.50cm X 11.11cm X 4.57cm

6.125" X 4.375" X 1.80"



MODEL: MLD-10, MLD-11 MIC-LINE DRIVER W/HEADPHONE AMP & IFB LISTEN

The MLD-10 and MLD-11 are mic-line drivers with built-in headphone amplifiers. They are designed to be used with boom microphones or parabolic microphones so that the operator of the microphone can hear what is being sent down the line. Included in the unit is another headphone amplifier for use in an IFB system.

The MLD-10 can phantom power the microphone and the MLD-11 has A-B power for the microphone. Both units operate from two 9 volt batteries which are housed in slide-lock battery cases that require no tools for battery change. The MLD-10 and MLD-11 have heavy-duty belt clips which are field removable. The headphone amplifiers can deliver a 1/4 watt into 8 ohms.

The units have two separate volume controls and 1/4" stereo jack on the front panel. Also located on the front is the on/off switch. The rear panel has both input and output XLRs for the microphone input, the other for the line input and line output. On the top panel there is a flow diagram on how the unit functions. The unit is constructed of black anodized aluminum panels and extrusion.

The MLD-10 and MLD-11 have three audio transformers; the input transformer for the microphone stage is a double shielded unit to prevent hum fields from entering the input stages when operated near AC hum fields; the input transformer for the line is single shielded. The output transformer provides a balanced output plus isolation from other devices that it connects. The units have 80dB of gain available of which 30dB are adjustable. The units use a low noise dual op-amp to achieve its specifications. The headphone amplifiers will deliver 1/4 watt into 8 ohms.

INPUT:

Transformer Balanced, Female XLR
Transformer Balanced, Female XLR
(line input)

INPUT IMPEDANCE:

150 ohms Balanced
15K ohms (Balanced Or unbalanced)

MAX. INPUT LEVEL:

-25dBv (mic)
+10dBv (line)

GAIN:

+75 to +41dB (adjustable)

NOISE:

-80dB Below Rated Output

FREQ. RESONSE:

+/-1db, 20-20,000Hz

BANDWIDTH:

45kHz @ -3dB

RISE TIME:

5uS (10%-90%)

DISTORTION:

<.20% @ 20Hz Max. Rated Output
<.10% @ 30Hz Max. Rated Output
<.04% @ 50Hz Max. Rated Output
<.011% @ 1kHz Max. Rated Output

OUTPUT:

Transformer Balanced, Male XLR

OUTPUT LOAD:

>600 ohms Balanced, Male XLR
>8 ohms (headphones)

OUTPUT LEVEL:

+16dBm Max.
1/4 watt (headphones)

POWER REQUIREMENTS:

One 9 volt battery (DC-DC converters)

POWER REQUIREMENTS:

MLD-10 48 volts phantom
MLD-11 12 12 volt AB power

DIMENSION:

15.50cm x 11.11cm x 4.57cm
6.125" x 4.375" x 1.80"



MODEL: ADA-1 MKII 1 X 4 AUDIO DA

The ADA-1 MKII is in a standard 1 3/4" rack mountable case; the unit has an internal 120 VAC power supply.

The ADA-1 MKII may be used as a four-channel line level distribution amplifier or as four individual line drivers. The common feed input is line-level balanced bridging. A second set of unbalanced inputs are provided by way of four 1/4" phone jacks which, when used, interrupt the corresponding line amplifier and all other higher numbered line amplifiers from the common feed. The gain of each line amplifier is screwdriver-adjustable from the front panel.

The outputs are 600 ohm transformer-balanced and have a maximum output level of +18dBm. The ADA-1 MKII may be used as a four-channel DA or with semi-professional tape machines or mixers as a line driver to bring these units up to +4dBm.



MODEL: ADA-2 2 X 8 AUDIO DA

The ADA-2 is a two-input and eight-output audio distribution amplifier in a standard 1-3/4" rack mountable case.

Eight front panel push-button type switches select either input A or B for each of the eight line amplifiers. This unique feature allows the ADA-2 to be used as a second DA when one input is not feeding all eight outputs. The inputs are transformer-balanced bridging, and front panel access is provided to the internal gain adjustments which have a range from 0dB to +30dB.

Each of the line amplifiers uses a pair of complimentary output transistors with an output impedance of less than 100 ohms which is coupled to the output transformer. The transformer has a turns ratio of 1:2 and, therefore, a gain of 6dB. This configuration allows the ADA-2 to provide a +30dBm maximum output level.

The unit is powered by an internal 120 VAC power supply.

SPECIFICATIONS:

INPUT:

- 1 Female XLR (common)
- 4-1/4" Phone Jacks (individual)

INPUT IMPEDANCE:

- 15K ohms Balanced (common)
- 150K ohms Unbalanced (individual)

MAX. INPUT LEVEL:

- +18dBv (common)
- +18dBv (individual)

GAIN:

- +30dB TO 0dB

NOISE:

- 100dB Below Rated Output

FREQ. RESPONSE:

- +/-1dB, 20-20k Hz

DISTORTION:

- <.2% @ 20Hz Max. Rated Output

OUTPUT:

- 4 Male XLR's

OUTPUT LOAD:

- >600 ohms Balanced

OUTPUT LEVEL:

- +18dBm Max.

POWER REQUIREMENTS:

- Internal Selectable
- 120VAC or 240VAC, 50/60Hz

DIMENSION:

- 48.66cm x 4.44cm x 12.70cm
- 19.00" x 1.75" x 5.00"

SPECIFICATIONS:

INPUT:

- 2 Female XLRs (A & B)

INPUT IMPEDANCE

- 15K ohms Balanced (A & B)

MAX. INPUT LEVEL:

- +18dBv (A & B)

COM.-MODE REJECTION RATIO:

- .87dB @ 1kHz -76dB @ 10kHz

GAIN:

- +30dB

NOISE:

- 101dB below Rated Output

FREQ. RESPONSE:

- +/-1dB, 20-20K Hz

DISTORTION:

- <.2% @ 20Hz at Max.

Rated Output

OUTPUT:

- 8 Male XLRs

OUTPUT LOAD:

- >600 ohms Balanced

OUTPUT LEVEL:

- +30dBm Max.

POWER REQUIREMENTS:

- 120VAC or 220VAC, 50/60Hz
- Internal Selectable

DIMENSION:

- INPUT:**
 2 RCA Phone jacks (amplifier)
 2 female XLRs (transformer)
- INPUT IMPEDANCE**
 100K ohms Unbalanced (amplifier)
 600 ohms Balanced (transformer)
- MAX. INPUT LEVEL:**
 +18dBv (amplifier)
 +18dBv (transformer)
- GAIN:**
 0dB to +30dB (amplifier)
 -14dB (transformer)
- NOISE:**
 -101dB Below Rated Output
- FREQ. RESPONSE:**
 +/-1dB, 20-20k Hz
- DISTORTION:**
 < 2% @ 20Hz Max. Rated Output
- OUTPUT:**
 2 Male XLRs (amplifier)
 2 RCA Phone Jacks (transformer)
- OUTPUT LOAD:**
 >600 ohms Balanced (amplifier)
 >600 ohms Unbalanced (transformers)
- OUTPUT LEVEL:**
 +18dBm Max. (amplifier)
 +6dBm Max. (transformer)
- POWER REQUIREMENTS:**
 120VAC or 240VAC, 50/60Hz
 Internal Selectable
- DIMENSION:**
 48.66cm X 13.21cm X 12.70cm
 19.00" X 5.25" X 5.00"

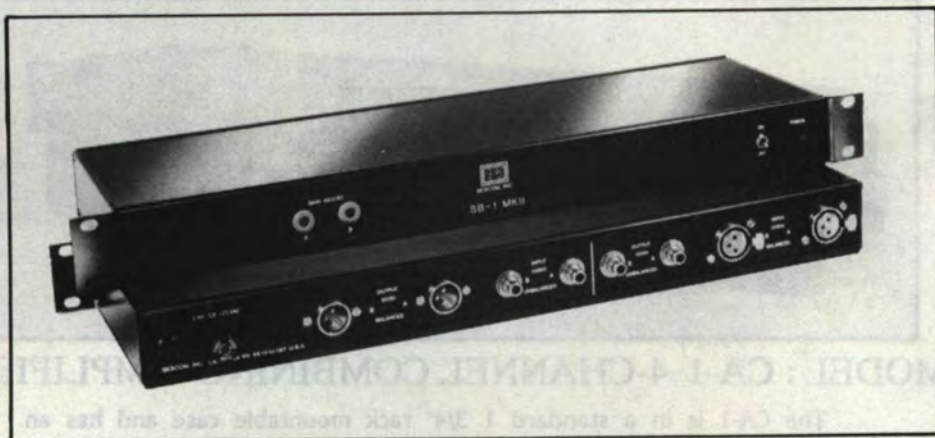

MODEL: SB-1 MKII STEREO BUFFER

The SB-1 MKII is in a 1 3/4" rack mountable case.. Also, the unit has an internal 120VAC power supply.

The SB-1 MKII provides a convenient means to interface a two-channel semi-professional tape recorder or VTR with -10dBv levels to a professional mixer with +4dBm levels.

The unit is divided into two sections. The amplifier section will accept the recorder outputs and is 100K ohms unbalanced bridging. The outputs of this section are 600 ohms transformer-balanced, which are used to feed the line level inputs of the mixer. The gain is adjustable from the front panel.

MODEL: PB-1 / PB-2

PATCHBAY

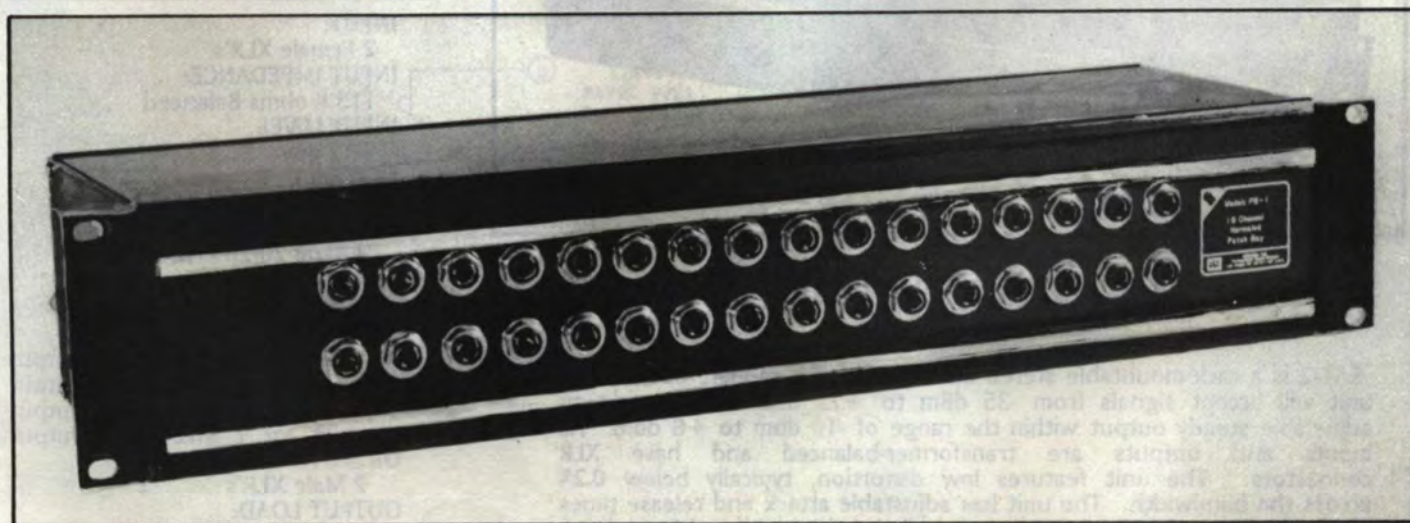

The PB-1 is primarily designed for use in four and eight-track studios. It features ease of installation with no soldering and balanced line operations. Standard molded type cables may be used for connecting the studio equipment to the PB-1.

Designation strips and 16 pairs of patch points using RTS 1/4" phone jacks in a normaled configuration are provided on the front panel. An additional 16 RTS 1/4" phone jacks are located on the rear panel for connecting the patch points to the studio equipment. RTS 1/4" phone jacks of the insulated sleeve type are used so as to help prevent ground loops from occurring.

Also available is a non-normaled configuration: the PB-2.



MODEL : CA-1 4-CHANNEL COMBINING AMPLIFIER

The CA-1 is in a standard 1 3/4" rack mountable case and has an internal 120/240 VAC power supply.

The CA-1 is a four-channel line level combining amplifier. The inputs are transformer-balanced. There are four individual front panel level controls plus a master with a VU meter. The output is also transformer-balanced. Each input is fed to a separate OP-AMP with gain and then fed to a virtual ground combining amplifier and finally to an output buffer amplifier.

The inputs are 15K ohms bridging and the output is 600 ohms. They may be used as a line level mixer.

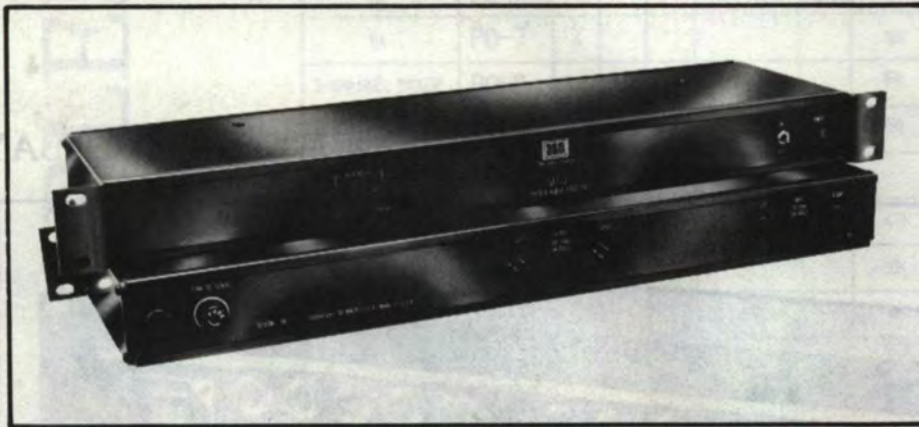

MODEL: SAT-2 STEREO AUDIO LEVELER

SAT-2 is a rack-mountable stereo audio leveler for satellite audio. The unit will accept signals from -35 dBm to +12 dBm and provide an adjustable steady output within the range of -10 dbm to +8 dbm. All inputs and outputs are transformer-balanced and have XLR connectors. The unit features low distortion, typically below 0.2% across the bandwidth. The unit has adjustable attack and release times which are internal. The SAT-2 is one rack unit high and is AC powered.

INPUT:

4 Female XLR's

INPUT IMPEDANCE:

15K ohms Balanced

MAX. INPUT LEVEL :

+18dBv

GAIN:

12dB (LINE)

NOISE:

-90dB Below Rated Output

FREQ. RESPONSE:

+/-1dB, 20-20k Hz

DISTORTION:

<.2% @ 20Hz Max Rated Output

OUTPUT:

1 Male XLRs

OUTPUT LOAD:

>600 ohms Balanced

OUTPUT LEVEL:

+18dBm Max.

POWER REQUIREMENTS:

120VAC or 240VAC, 50/60Hz

Internal Selectable

DIMENSION:

48.66cm X 4.44cm X 12.70cm

19.00" X 1.75" X 5.00"

SPECIFICATIONS:

INPUT:

2 Female XLR's

INPUT IMPEDANCE:

115 K ohms Balanced

INPUT LEVEL

+12 dBv

NOISE:

-85 dB Below Max. Output

FREQ. RESPONSE:

+/-1dB 20-20 kHz

BANDWIDTH:

45 kHz @ -3 dB

DISTORTION:

<.2% @ 20 Hz Max. Output

<.2% @ 30 Hz Max. Output

<.2% @ 50 Hz Max. Output

<.2% @ 1 kHz Max. Output

OUTPUT:

2 Male XLR's

OUTPUT LOAD:

<600 ohms Balanced

OUTPUT LEVEL:

+21 dBm Max.

POWER REQUIREMENTS:

120VAC or 220VAC, 50/60Hz

Internal Selectable

DIMENSION:

48.66 cm X 4.44 cm X 12.70 cm

19.00" X 1.75" X 5.00"

SPECIFICATIONS:

- INPUT:**
4 Female XLR
- INPUT IMPEDANCE:**
15K ohms Balanced
- MAX. INPUT LEVEL:**
+18dBv
- GAIN:**
+36 dB
- NOISE:**
-101dB Below
Rated Output
- FREQ. RESPONSE:**
+/-1dB, 20-20k Hz
- DISTORTION:**
<.2% @ 20Hz
Max. Rated Output
- OUTPUT:**
1 1/4" headphone jack
1 4" speaker (internal)
- OUTPUT LOAD:**
>8 ohms unbalanced
- OUTPUT LEVEL:**
+10 watts max
- POWER REQUIREMENTS:**
120VAC or 240VAC, 50/60Hz
Internal Selectable
- DIMENSION:**
48.66cm X 13.21cm X 12.70cm
19.00" X 5.25" X 5.00"



MODEL: MON-1 4-CHANNEL MONITOR AMPLIFIER

The MON-1 is in a 5 1/4" rack mountable case and has an internal 120/240 VAC power supply. The MON-1 is a selectable four-channel line level monitoring amplifier with built-in speaker. The unit features balanced-transformer inputs, which are front panel selectable, and a level control. The inputs are 15K bridging and the amplifier power is 10 watts RMS with front panel headphone jack.

The input connectors are XLR female. The unit is designed for rack systems to monitor line level signals.

SPECIFICATIONS:

- INPUT:**
2 RCA Phono Jacks (phono)
2 XLR Female (line)
2 1/4" Phone Jacks (line)
- INPUT IMPEDANCE:**
47K ohms Unbalanced (phono)
15K ohms Balanced (line)
47K ohms Unbalanced (line)
- MAX. INPUT LEVEL:**
+18dBv (line)
- GAIN:**
+54dB (phono) 0dB (line)
- NOISE:**
-90dB Below Rated Output
- FREQ. RESPONSE:**
+/-1dB, 20-20K Hz
RIAA Nominal (phono)

- DISTORTION:**
<.2% @ 20Hz Max. Rated Output
- OUTPUT:**
2 Male XLRs (A & B output)
1 Male XLR (mono output)
- OUTPUT LOAD:**
>600 ohms Balanced (A & B output)
>600 ohms (mono output)
- OUTPUT LEVEL:**
+18dBm Max. (A & B output)
+18dBm Max. (mono output)
- POWER REQUIREMENTS:**
120VAC or 220VAC, 50/60Hz
Internal Selectable
- DIMENSION:**
48.66cm X 4.44cm X 12.70cm
19.00" X 1.75" X 5.00"



MODEL: SC-3

The SC-3 is a stereo RIAA phono pre-amp with super low noise, line amplifier and a stereo combiner. The unit features a 1 3/4" rack mountable case and a 120 VAC internal power supply.

The front panel switches permit selection of either RIAA phono inputs or line level inputs. A unity gain buffer is provided as the first stage to provide low input capacitance for the phono input.

The SC-3 inputs are RIAA phono, line level unbalanced 1/4" phone jacks and transformer-balanced female XLR. The SC-3 has three 600 ohm transformer-balanced outputs; two for the left and right stereo outputs, and the third is a mono output. The SC-3 inputs are RIAA phono, line level unbalanced 1/4" phone jacks and transformer-balanced female XLRs.



MODEL: SH-1 MKII STEREO HEADPHONE AMPLIFIER

The SH-1 MKII is in a 1 3/4" rack mountable case, The unit has a 120 VAC power supply.

The SH-1 MKII is a 10-watt per channel stereo power amplifier designed for use in the studio, AV facilities and broadcasting. Used in conjunction with the SHB-1 MK II (headphone junction box), the SH-1 MKII can drive multiple sets of headphones. Also, it may be used to drive small control room monitors or talk-back speakers.

Front panel level controls and headphone jack are provided. The input connectors are RCA phono jacks, and the output connectors are binding posts for each output, and one male 3-pin XLR for direct connection to the SHB-1. The power supply features a low flux field toroidal power transformer.

MODEL: SHB-1 MKII STEREO HEADPHONE BOX



The SHB-1 MKII is designed for use with the SH-1 MKII power amplifier as a stereo headphone junction box. It also may be used with any 10 to 75 watt stereo amplifier.

Looping inputs and outputs are provided using a female XLR type connector and RTS phone jack for the looping input. The looping output uses a male XLR type connector and RTS phone jack. The six headphone outputs also use RTS phone jacks, and each of the six outputs has build-out resistors for isolation. Any headphones between 8 ohms and 2000 ohms may be used.

Standard two-conductor shielded microphone type cable with 3-pin XLR type connectors can be used to connect the SHB-1 MKII to an SH-1 MKII or to additional SHB-1's by use of the looping inputs and outputs.

SPECIFICATIONS:

INPUT:

2 RCA Phono Jacks

INPUT IMPEDANCE:

100K ohms Unbalanced

INPUT SENSITIVITY:

.25 Volts for Rated Output

NOISE:

-93 dB Below Rated Output

FREQ. RESPONSE:

+/-1 db, 20-20 KHz (.5 watts)

+/-1 db, 30-20 KHz (10 watts)

BANDWIDTH:

100 kHz @ -3 dB

RISE TIME:

3.0 us (10%-90%)

PHASE RESPONSE:

-12 Degree @ 20 kHz

DISTORTION:

<0.1% @ 20 Hz Max. Rated

Output

<0.1% @ 1 kHz Max. Rated

Output

<0.15% @ 20 kHz Max. Rated

Output

OUTPUT:

1 3-Pin Male XLR

2 Dual Binding Posts

OUTPUT POWER:

10 Watts RMS/8 ohms

Both Channels Driven

POWER REQUIREMENTS:

120VAC or 220VAC, 50/60Hz

Internal Selectable

DIMENSION:

48.66 cm X 4.44 cm X 12.70 cm

19.00" X 1.75" X 5.00"

SPECIFICATIONS:

INPUT:
 1 Female XLR
INPUT IMPEDANCE:
 150 or 600 ohms Balanced MAX.
INPUT LEVEL:
 +24dBv Max.
COM.-MODE REJECTION RATIO:
 -80dB @ 1kHz -60dB @10kHz
GAIN:
 +6dB (150 ohm)(unterminated)
 0dB (600 ohm)(unterminated)
FREQ. RESPONSE:
 +/-1dB, 20-20K Hz
DISTORTION:
 <.20% @ 20Hz Max. Rated Output
 <.15% @ 30Hz Max. Rated Output
 <.085% @ 50Hz Max. Rated Output
 <.003% @ 1kHz Max. Rated Output
OUTPUT:
 4 Male XLRs
OUTPUT LOAD:
 >600 ohms Balanced
OUTPUT LEVEL:
 +30dBm Max.
DIMENSION:
 48.66cm X 4.44cm X 12.70cm
 19.00" X 1.75" X 5.00"

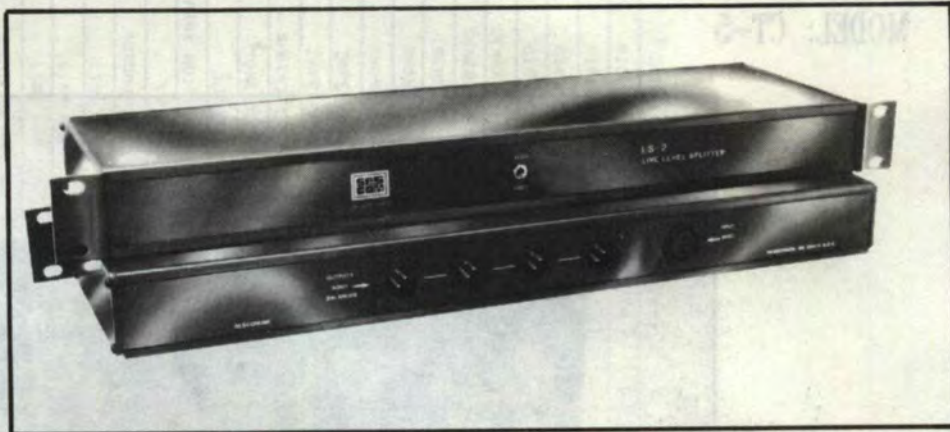

MODEL: LS-2 LINE LEVEL SPLITTER

The LS-2 is designed to provide up to four isolated transformer-balanced outputs from one input. It may be used in the same way as an audio distribution amplifier when active electronics are not needed. It is most useful when an output feed must be run a long distance and then split to run in several different directions.

The input is selectable 150 or 600 ohms transformer-balanced, and the transformer has four 600 ohm balanced secondaries. Build-out resistors are placed between the transformer secondary and the XLR outputs for further isolation. The LS-2 has a maximum output level of +30dBm.

SPECIFICATIONS:

INPUT:
 1 Female XLR
INPUT IMPEDANCE:
 150 or 600 ohms Balanced
MAX. INPUT LEVEL:
 +24dBv
COM.-MODE REJECTION RATIO:
 -90dB @ 1kHz
 -60dB @ 10kHz
GAIN:
 +6dB (150 ohm)(unterminated)
 0dB (600 ohm)(unterminated)
FREQ. RESPONSE:
 +/-1dB, 20-20K Hz
DISTORTION:
 <.20% @ 20Hz Max. Rated Output
 <.15% @ 30Hz Max. Rated Output
 <.085% @ 50Hz Max. Rated Output
 <.003% @ 1kHz Max. Rated Output
OUTPUT:
 4 Male XLRs
OUTPUT LOAD:
 >600 ohms Balanced
OUTPUT LEVEL:
 +30dBm Max.
DIMENSION:
 48.66cm x 4.44cm x 12.70cm
 19.00" x 1.75" x 5.00"



MODEL: OB-2 OUTPUT BALANCER

The OB-2 is designed to provide a means to convert line level, 600 ohm unbalanced outputs to 600 ohm balanced outputs. The unit features two channels, each with a maximum input level of +30dBm. Both female XLR's and 1/4" phone jacks are provided for the inputs while male XLR's are used for the outputs.

The use of balanced lines is helpful in reducing noise as the shield is not a signal-carrying connector. When used properly, balanced lines are of great benefit when ground loops are encountered. The OB-2 is ideally suited for use with semi-professional tape recorders, V T R's and semi-professional mixers.

MODEL: CT-5

CABLE TESTER

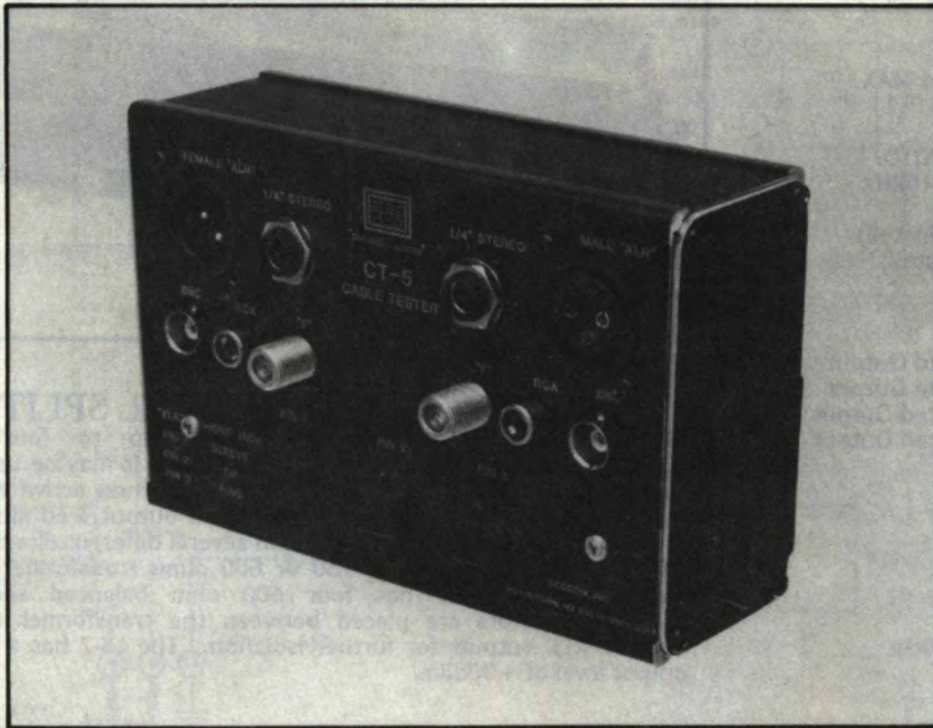

MODEL: CT-5

The CT-5 is designed to test cables that have male and female XLRs, as well as RTS phone plugs, RCA phono plugs, "F", or BNC connectors. The unit will test for opens, shorts or proper phase and is powered by a 9 volt transistor battery which is housed in a plastic slide lock case (requires no tools for battery changes). The cable tester uses three normally-closed push-button type switches with built-in LED's. When a switch is depressed, it turns off the corresponding LED. Since the switches do not have to be depressed to turn on the LED's, one hand is free to move the cable about to determine if one of the ends is intermittently open.

If cables in the studio or the field are checked before being used, much time and aggravation can be saved during the performance. The size of the box is 5-1/2" wide by 1-3/4" high by 3-1/2" deep.

The ASG-2 is a hand-held battery operated sine-wave audio generator. It is designed for field use and is housed in a rugged aluminum case. The battery is in a slide-lock compartment that requires no tools for change. The sine-wave generator is a typical wien-bridge oscillator circuit with a thermistor for thermal stabilization. The unit has low distortion, typically under .05% across the band. The unit will generate frequencies from 20-20K Hz. The ASG-2 has three-decade switching plus eight switches to determine the exact operating frequency. There is a push-button switch for turning the unit on and off.

The output level is a maximum +10dBm to -60dBm and has both balanced and unbalanced outputs. The balanced output is electronically done. The output levels are determined by two rotary switches. One switch is for the decades in 10dB increments and the other rotary switch is in 1 db increments. The unit will drive 600 ohm loads.

The size of the unit is 3.6" X 5.5" X 1.8". The unit draws under 150 ma.



MODEL: ASG-2 AUDIO SINE-WAVE GENERATOR

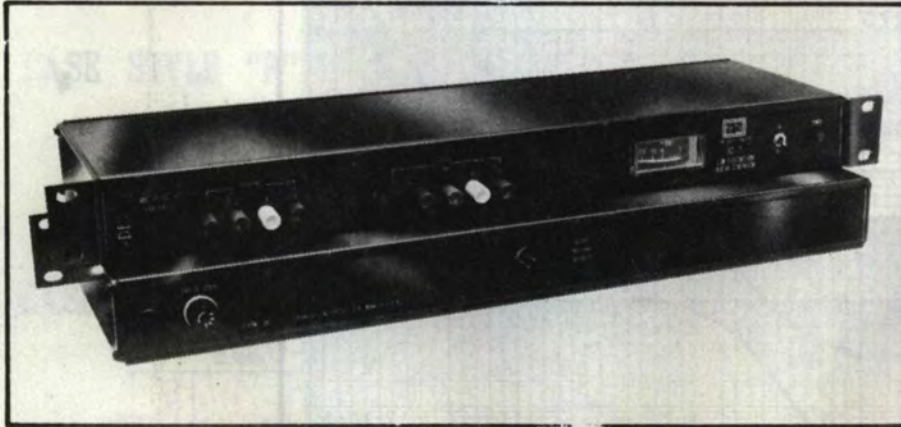

MODEL: AG-1 AUDIO GENERATOR

The AG-1 is a rack mounted low-distortion audio generator. The unit features push-button frequency selection and decade control. The range of selectable frequencies is from 100 Hz to 15 KHz which is very usable in studio applications. The output levels are +20, +8, +4, 0 and -10 dBm transformer-balanced. The unit also has a VU meter which tracks the output level. The AG-1 is one rack unit high and is AC powered.

SPECIFICATIONS:

FREQ. RESPONSE

+/-1dB 100-15,000 Hz

DISTORTION:

Max. Rated Output

<.05% @ 20Hz

<.05% @ 30Hz

<.05% @ 50Hz

<.01% @ 1kHz

OUTPUT:

1 Male XLR

OUTPUT LOAD:

>600 Ohms Balanced

OUTPUT LEVEL:

+20 dBm Max.

POWER REQUIREMENTS:

120VAC or 220VAC, 50/60Hz

Internal Selectable

DIMENSION:

48.66 cm X 4.44 cm X 12.70 cm
19.00" X 1.75" X 5.00"

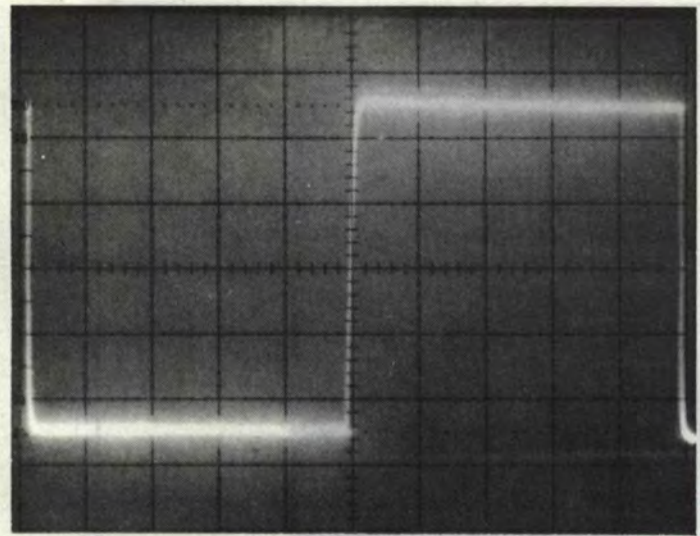

2kHz Square Wave

50µS/division

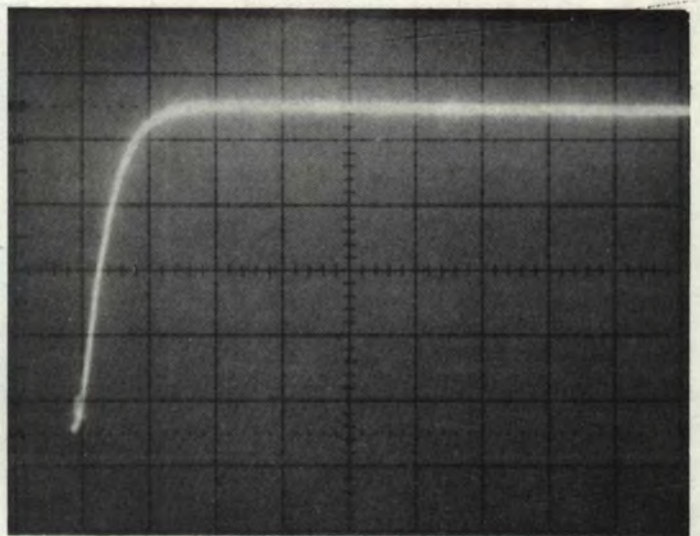

2kHz Square Wave

5µS/division

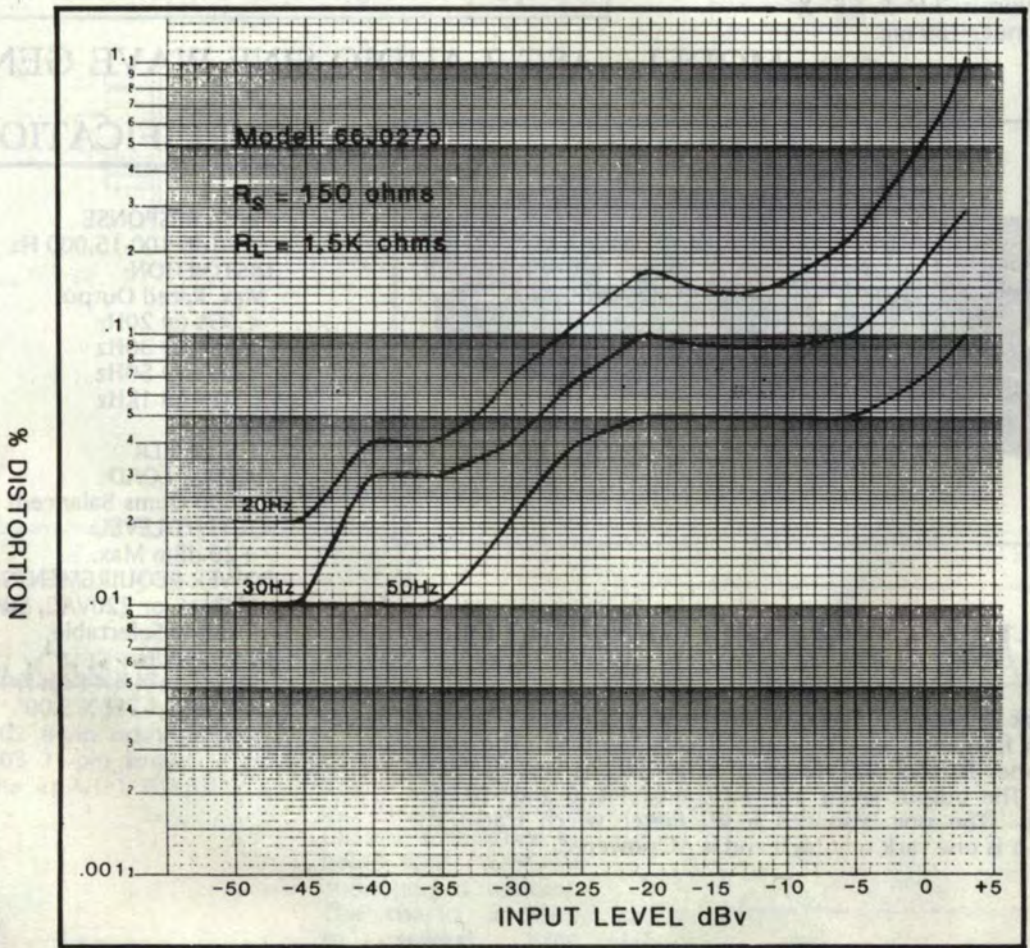



MODEL: MS-11
LOW IMPEDANCE MIC-SPLITTER

MODEL: MS-14
1 X 3 LOW IMPEDANCE MIC-SPLITTER

MODEL: MS-15
4 X 3 LOW IMPEDANCE MIC-SPLITTER

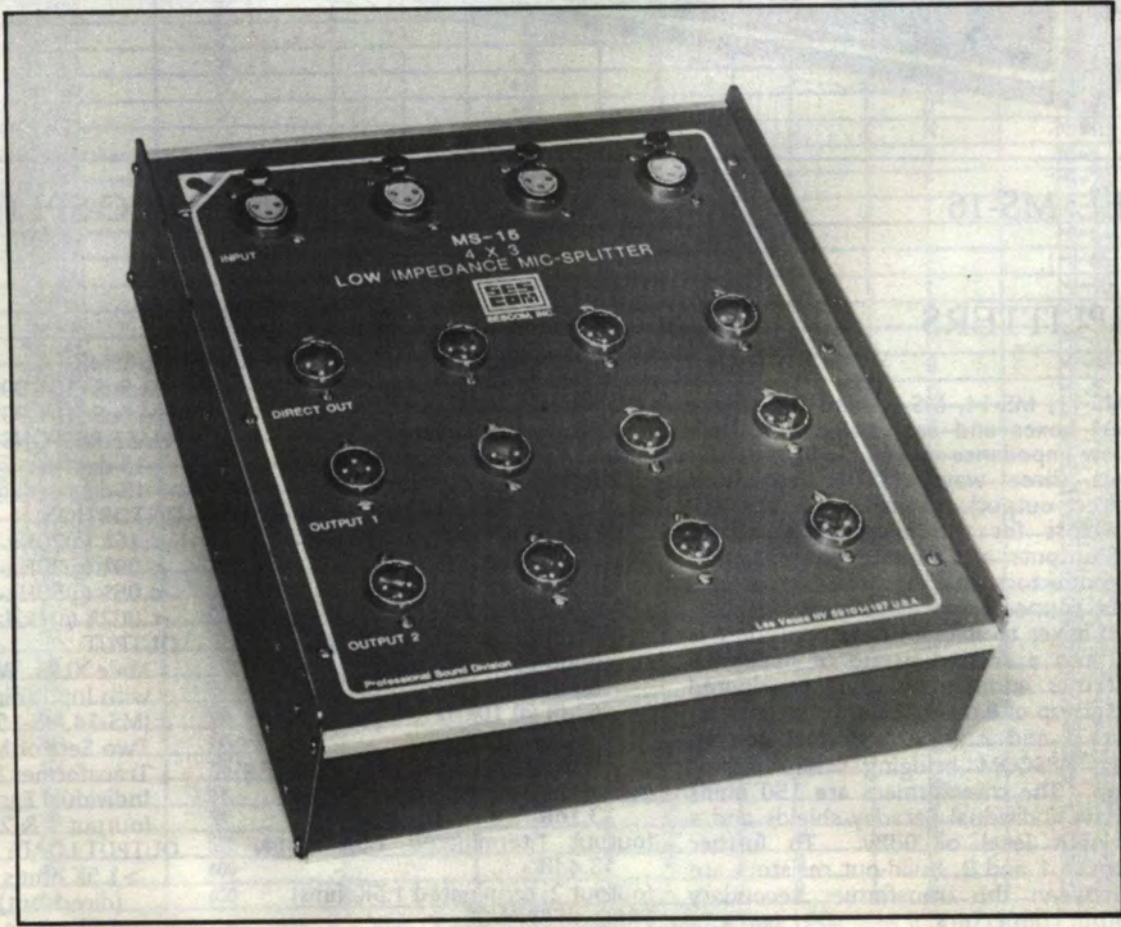

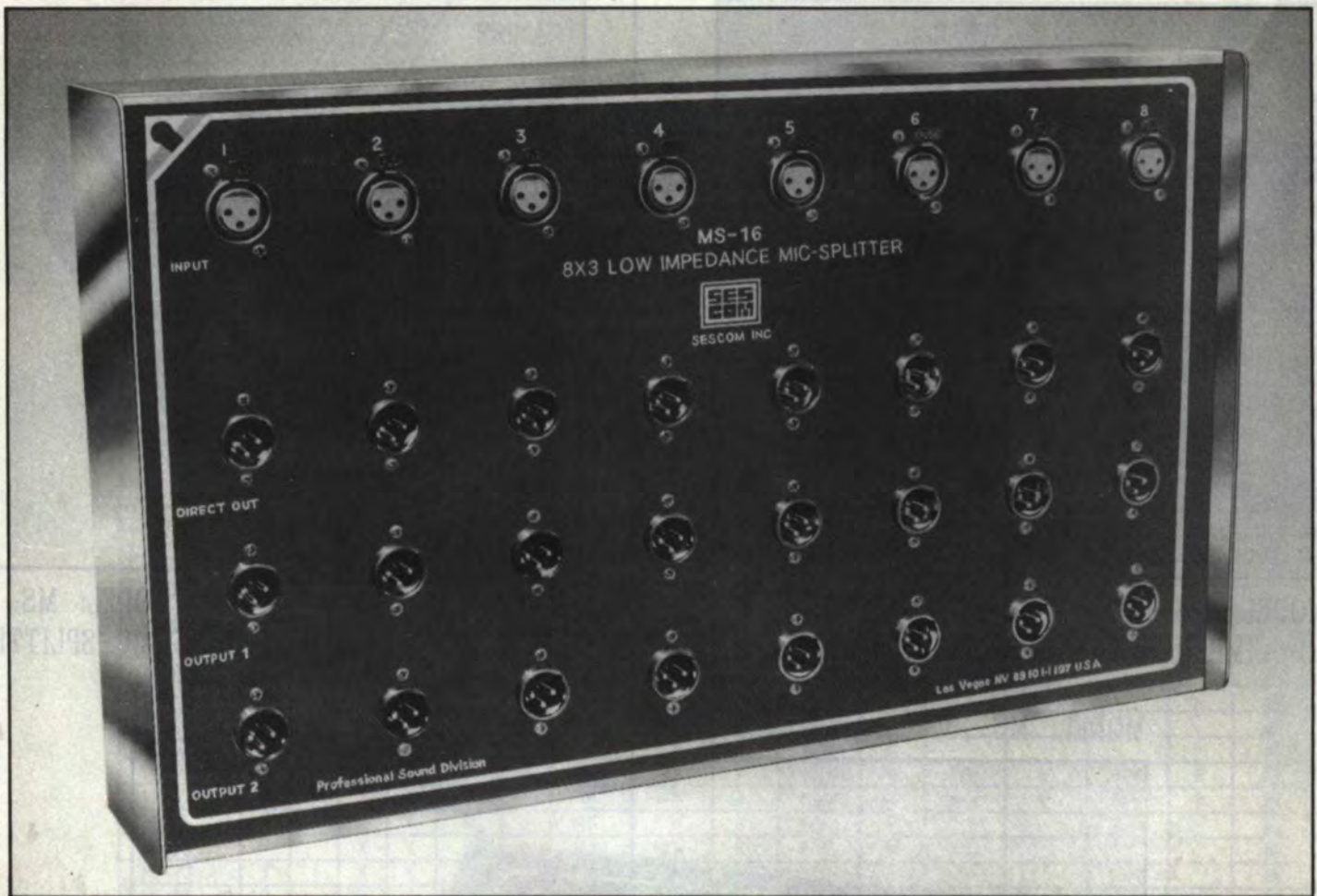

MODEL: MS-16

8 X 3 LOW IMPEDANCE MIC-SPLITTER

MIC-SPLITTERS

SPECIFICATIONS:

INPUT:

4 Female XLRs

INPUT IMPEDANCE:

150 ohms Balanced

INPUT LEVEL @ 1% SATURATION:

0dBv @ 20Hz

+5.5dBv @ 30Hz

+12dBv @ 50Hz

MAX. INPUT LEVEL:

+3dBv

COM.-MODE REJECTION RATIO:

-96dB @ 1kHz (output 1)

-68dB @ 10kHz (output 1)

-86dB @ 1kHz (output 2)

-63dB @ 10kHz (output 2)

INSERTION LOSS:

0dB

(direct out terminated 1.5 ohms)

-3.1dB

(output 1,terminated 1.5K ohms)

-3.4dB

(output 2, terminated 1.5Kohms)

FREQ. RESPONSE:

+/-1dB, 20-20K Hz

BANDWIDTH:

96kHz @ -3dB (output 1)

92kHz @ -3dB (output 2)

RISE TIME:

3.5uS (10%-90%) (output 1)

4.0uS (10%-90%) (output2)

PHASE RESPONSE:

-15 degrees @ 20kHz (output 1)

-15 degrees @ 20kHz (output 2)

DISTORTION:

<.16% @20Hz-10dB Input

<.09% @30Hz-10dBv Input

<.05% @50Hz-10dB vInput

<.002% @1kHz -10dB vInput

OUTPUT:

Male XLRs, Wired in Parallel

with Input(direct out)

(MS-14,MS-15,MS-16 Only)

Two Sets of Male XLRs,

Transformer Isolated with

Individual Faraday Shields

(output 1 & 2)

OUTPUT LOAD:

>1.5K ohms Balanced

(direct out)

>1.5K ohms Balanced

(output1&2)

The MS-11, MS-14, MS-15 and MS-16 are "Mic-Splitter" boxes and are designed to split 1, 4 or 8 low impedance dynamic or condenser microphones three ways (MS-11 two ways only, no direct output). There are female XLR type connectors for the microphone inputs. The direct outputs are terminated into male XLR type connectors and are wired in parallel to the input connector so as to pass phantom supply from mixer to microphone. Output 1 is terminated into a second group of male XLR type connectors and Output 2 is terminated into a third group of 8 male XLR's.

Outputs 1 and 2 are transformer-isolated with special SESCOM bridging "Mic-Splitter" transformers. The transformers are 150 ohms balanced, have individual Faraday shields and a maximum input level of 0dBv. To further isolate Outputs 1 and 2, build-out resistors are inserted between the transformer secondary and the output connectors.

SPECIFICATIONS:

INPUT:
 2 Female XLRs
INPUT IMPEDANCE:
 150 ohms Balanced
INPUT LEVEL @ 1% SATURATION:
 0dBv @ 20Hz
 +5.5dBv @ 30Hz
 +12dBv @ 50Hz
MAX. INPUT LEVEL:
 +3dBv **INSERTION LOSS:**
 -3.4dB
FREQ. RESPONSE:
 +/-1dB, 20-20K Hz
BANDWIDTH:
 92kHz @ -3dB
RISE TIME:
 4.0uS (10%-90%)
DISTORTION:
 <.16% @ 20Hz -10dBv Input
 <.09% @ 30Hz -10dBv Input
 <.05% @ 50Hz -10dBv Input
 <.002% @ 1kHz -10dBv Input
OUTPUT:
 1 Male XLR
OUTPUT LOAD:
 >1.5K ohms Balanced
DIMENSIONS:
 9.14cm X 13.97cm X 4.57cm
 3.60" X 5.50" X 1.80"

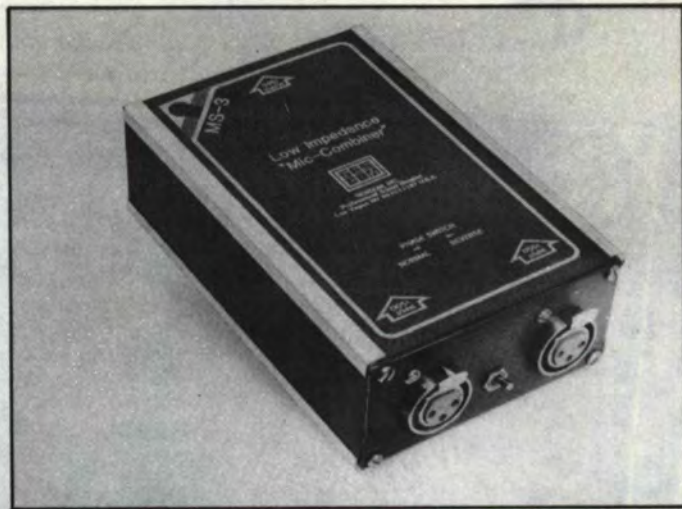

MODEL: MS-3
LOW IMPEDANCE MIC-SPLITTER

The MS-3 provides a convenient means for combining the outputs of two dynamic low impedance microphones. There are two female XLR connectors for the microphone inputs. The inputs are combined by means of a special SESCOM bridging "mic-combining" transformer. A phase reversal switch is provided for reversing the phase of the second input. The transformer is 150 ohms balanced and has a maximum input level of +3dBv. The output of the transformer is terminated in a male XLR.

MODEL: MS-5**1 X 4 MIC-SPLITTER / 4 TO 1 MIC-COMBINER****SPECIFICATIONS:**

INPUT:
 4 Female XLRs (combine)
 1 Female XLR (split)
INPUT IMPEDANCE:
 150 ohms Balanced
INPUT LEVEL @ 1% SATURATION:
 +3dBv @ 20Hz
 +8dBv @ 30Hz
 +14dBv @ 50Hz
MAX. INPUT LEVEL:
 +6dBv
INSERTION LOSS:
 -6dB (combine)
 -6dB (split)
FREQ. RESPONSE:
 +/-1dB, 20-20K Hz
DISTORTION:
 <.25% @ 20Hz Max. Rated Output
 <.16% @ 30Hz Max. Rated Output
 <.09% @ 50Hz Max. Rated Output
 <.003% @ 1kHz Max. Rated Output
OUTPUT:
 4 Male XLRs (split)
 1 Male XLR (combine)
DIMENSION:
 33.33cm x 14.92cm x 7.62cm
 13.125" x 5.875" x 3.0"

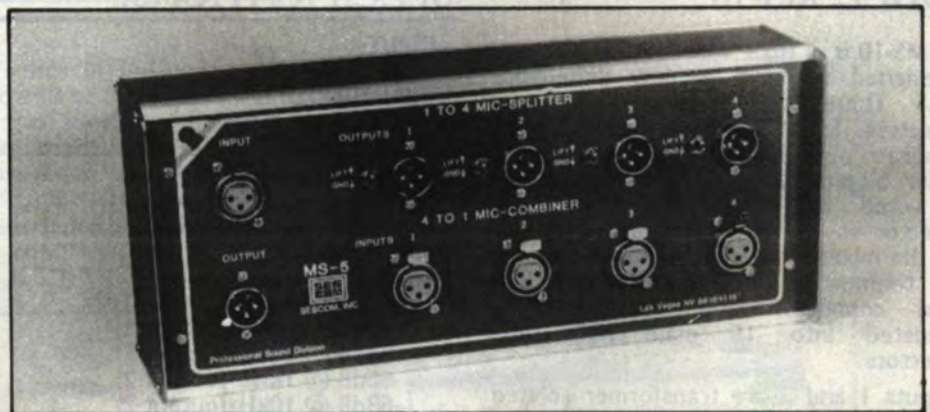

The MS-5 is a 1 to 4 "Mic-Splitter" and a 4 to 1 "Microphone Combiner". The combining section is designed to combine the outputs of four dynamic low impedance microphones. The split section is designed to split one dynamic low impedance microphone four ways. Each of the four connectors is provided with a ground lift switch in the splitting section. Therefore, the MS-5 can be used as a splitter and combiner at the same time. The transformer is 150 ohms balanced and has a maximum input level of +6dBv.



MODEL: MS-10

The MS-10 is a 16x3 "Mic-Splitter" box and is designed to split 16 low impedance ways. There are 16 female XLR type connectors for the microphone inputs. The direct outputs are terminated into a circular 52-pin "MIL-SPEC" connector and are wired in parallel to the input connector so as to pass phantom supply from the mixer to the microphone. Output 2 is terminated into a second circular 52-pin connector and output 1 is terminated into 16 male XLR type connectors.

Outputs 1 and 2 are transformer-isolated with special SESCOM bridging "Mic-Splitter" transformers. The transformers are 150 ohms balanced, have individual Faraday shields and a maximum input level of 0dB. To further isolate Outputs 1 and 2, build-out resistors are inserted between the transformer secondary and the output connectors. Multi-cables are also available from SESCOM to make MS-10 a complete multi-cable/"Mic-Splitter" system.

SPECIFICATIONS:

INPUT:

16 Female XLRs
 INPUT IMPEDANCE:
 150 ohms Balanced
 INPUT LEVEL: @ 1% SATURATION:
 0dB @ 20Hz
 +5.5dB @ 30Hz
 +12dB @ 50Hz
 MAX. INPUT LEVEL:
 +3dB

COM.-MODE REJECTION RATIO:

-96dB @ 1kHz (output 1)
 -68dB @ 10kHz (output 1)
 -86dB @ 1kHz (output 2)
 -63dB @ 10kHz (output 2)

INSERTION LOSS:

0dB
 (direct out, terminated 1.5K ohms)
 -31dB
 (output 1, terminated 1.5Kohms)
 -3.4dB
 (output 2, terminated 1.5K ohms)
 FREQ. RESPONSE:
 +/-1dB, 20-20K Hz

BANDWIDTH:

96kHz @ -3dB (output 1)
 92kHz @ -3dB (output 2)

RISE TIME:

3.5uS (10%-90%) (output 1)
 4.0uS (10%-90%) (output 2)

PHASE RESPONSE:

-15@20kHz (output 1)
 -15@20kHz (output 2)

DISTORTION:

<.16% @ 20Hz -10dBv Input
 <.09% @ 30Hz -10dBv input
 <.05% @ 50Hz -10dBv Input
 <.002% @ 1kHz -10dBv Input

OUTPUT:

Circular 52-Pin, Wired in Parallel with Input (direct out)
 Circular 52-Pin, Transformer Isolated individual Faraday Shields (output 2)
 16 Male XLRs, transformer Isolated with Individual Faraday Shield (output 1)

OUTPUT LOAD:

>1.5K ohms Balanced (direct out)
 >15K ohms Balanced (output 2)

DIMENSION:

43.50cm X 27.30cm X 7.62cm
 17.13" X 10.75" X 3.00"

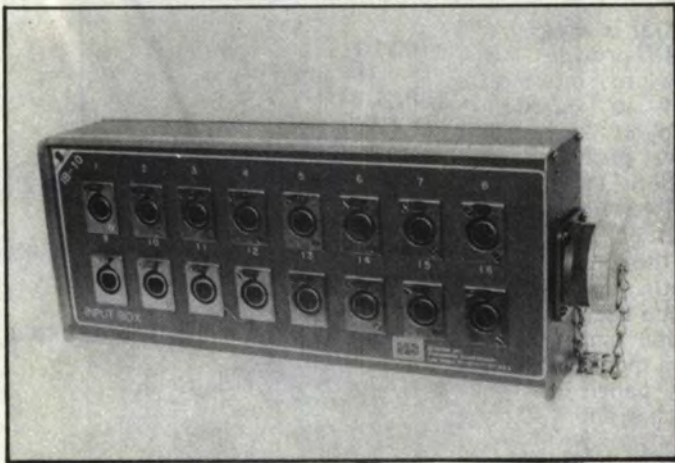

MODEL: IB-10

The IB-10 is designed to be used in place of the MS-10 when it is not necessary to use a "Mic-Splitter". There are 16 female XLR type connectors and they are terminated into a circular 52-pin "MIL-SPEC" connector. Accessories for use with the IB-10 are S-50, S-100 and S-200 mult cables and the S-CF and S-CF termination ends. These items will make a complete 16-input mult system in any length without the need for interface boxes to extend the length of the cable.

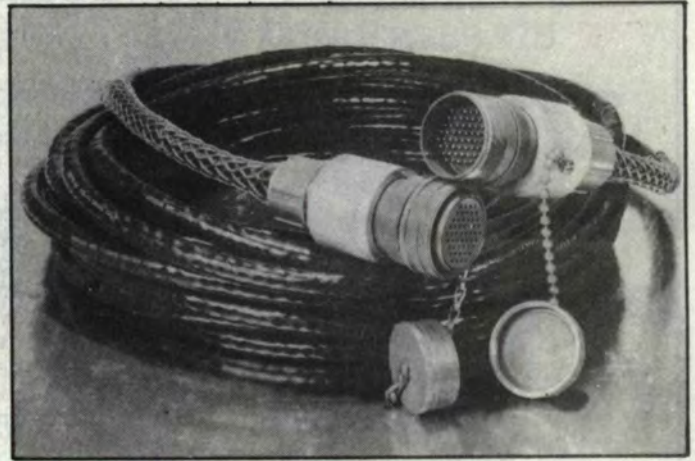

MODEL: S-50, S-100, S-200

The cable for the S-50, S-100 and S-200 is a Belden 9736. It is 22 ga, stranded wire which is helixed up in a short lay with a drain wire added. The three are covered with aluminumized mylar foil to provide a shield. To prevent the shields from shorting to each other a clear mylar is placed over the foil shield. The outer jacket is made of PVC to provide the cable with a tough and durable cover. The cable is available 50, 100 and 200 foot lengths with male and female circular 52-pin connectors.

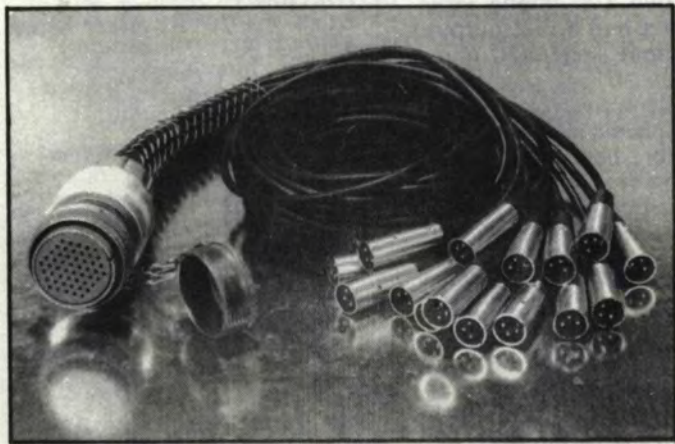

MODEL: S-CM

The S-CM has 16 male XLR type connectors and on the other end of the five connector with a cap and chain.



MODEL: S-CF

The S-CF has 16 female XLR type connectors and on the other end of the five foot cable is a circular 52-pin male connector with a cap and chain.

MODEL: SM-1A MKII PASSIVE DIRECT BOX



The SM-1A MKII is a passive direct box and provides a convenient means to interface the output of a musical instrument pick-up or keyboard with an output level of 20 mV or more to a microphone input of a mixing console. Two 1/4" phone jacks are provided on the front panel, one for the instrument input and the other is a Hi-Z output which may be used to feed the input of a guitar amplifier so it may be used as a monitor. Also on the front panel is a pickup/amp switch and filter switch.

The microphone level output is 150 ohms transformer-balanced, and a ground lift switch is provided.

INPUT:

1 1/4" phone jack

INPUT IMPEDANCE:

60K ohms Unbalanced

MAX. INPUT LEVEL:

+15 dBv

GAIN:

-26 dB (pick-up) -56 dB (amp)

FREQ. RESPONSE:

+/-1 dB, 20-20 KHz

DISTORTION:

<.03% @ 20 Hz Max. Rated Output

OUTPUT:

1 1/4" phone jack (Hi-Z)

1 Male XLR (mic)

OUTPUT LOAD:

>1.5K ohms Balanced (mic)

DIMENSION:

9.14 cm X 13.97 cm X 4.57 cm

3.60" X 5.50" X 1.80"

MODEL: SM-2 MKII ACTIVE DIRECT BOX



The SM-2 MKII is an active direct box and may be used to interface a musical instrument pickup or keyboard to the microphone input of a mixing console.

The SM-2 MKII uses a single bi-fet op-amp and 1:1 output transformer which enables it to work with instruments that have weak output levels (less than 20 mV). The SM-2 MKII has two 1/4" phone jacks for the instrument input and a Hi-Z output. The output is microphone level, 150 ohms transformer-balanced.

One internal 9 volt transistor battery, which is housed in a plastic slide-lock case (requires no tools for battery changes) supplies power for the unit, or it may be powered by the phantom supply of the mixing console it is feeding. Also a 24VDC power jack is provided.

INPUT:

1 1/4" Phone Jack

INPUT IMPEDANCE:

>5m ohms Unbalanced

MAX. INPUT LEVEL:

+0 dBv

GAIN:

0 dB (unity)

FREQ. RESPONSE:

+/-1 dB, 20-20 KHz

DISTORTION:

<.04% @ 20 Hz Max. Rated

Output OUTPUT:

1 1/4" Phone Jack (Hi-Z)

1 Male XLR (mic)

OUTPUT LOAD:

>1.5K OHMS BALANCED (mic)

POWER REQUIREMENTS:

One 9V Battery, 24 VDC

Phantom Power Jack

DIMENSION:

9.14 cm X 13.97 cm X 4.57 cm

3.60" X 5.50" X 1.80"

MODEL: SM-4 MKII SIMPLE PASSIVE DIRECT BOX



The SM-4 MKII is a simple passive direct box and provides a means to interface a musical instrument pickup or keyboard, with an output of 20mV or more, to a microphone input of a mixer console.

The input is high impedance, with two 1/4" phone jacks, allowing a guitar to be used as a monitor while simultaneously providing a send to the mixing console.

The microphone level output is 150 ohms transformer-balanced and uses a special transformer to eliminate most ground loop problems.

INPUT:

1 1/4" Phone Jack

INPUT IMPEDANCE:

60k ohms Unbalanced

MAX. INPUT LEVEL:

15dBv

GAIN:

-26dB

FREQ. RESPONSE:

+/-1dB, 20-20K Hz

DISTORTION:

.03% @ 20Hz Max. Rated Output

OUTPUT:

1 1/4" Phone Jack (Hi-Z)

1 male XLR (mic)

OUTPUT LOAD:

>1.5K ohms Balanced

DIMENSION:

9.14cm x 13.97cm x 4.57cm

3.60" x 5.50" x 1.80"

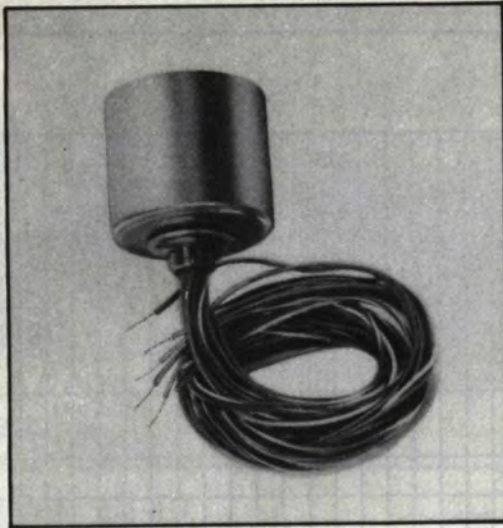

MODEL:
66J0036A,40A,92A

INPUT IMPEDANCE:
150 ohms Balanced
MAX. INPUT LEVEL:
-10dBv
FREQ. RESPONSE:
+/-1dB, 20-20KHz
DISTORTION:
<0.2% @ 30Hz - 10dBv Input
<0.1% @ 1KHz - 6dBv Input
OUTPUT LOAD:
> 1.5K ohms Balanced
MOUNTING:
3/8"-32 Bushing
FARADAY SHIELD:
One for each winding
SHIELDING:
-60dB
DIMENSION:
3.49 cm X 3.33 cm
1 3/8" X 1 5/16"

MODEL:
66J0036B,40B,92B

INPUT IMPEDANCE:
150 ohms Balanced MAX.
INPUT LEVEL:
+6dBv
FREQ. RESPONSE:
+/-1dB, 20-20KHz
DISTORTION:
<0.2% @ 30Hz + 6dBv Input
<0.1% @ 1KHz + 6dBv Input
OUTPUT LOAD:
> 1.5K ohms Balanced
MOUNTING:
3/8"-32 Bushing
FARADAY SHIELD:
One for each winding
SHIELDING:
-60dB
DIMENSION:
3.49 cm X 3.33 cm
1 3/8" X 1 5/16"

TYPICAL EXAMPLE OF A MIC-SPLITTING BOX

The models 66J0036A & B (two splits), 66J0040A & B (three splits), and 66J0092A & B (four splits), are specially designed audio transformers used for splitting microphones in remote recording studios, churches and TV production. These transformers have separate isolated electro-static shields to prevent common ground-loop problems. They are enclosed in double-shielded nested cans for hum protection. They can also be rotated in their mounting for minimum hum. The Mic-Splitting transformers are designed to be used in a bridging mode to maximize transfer of power without loss of signal or derating performance.

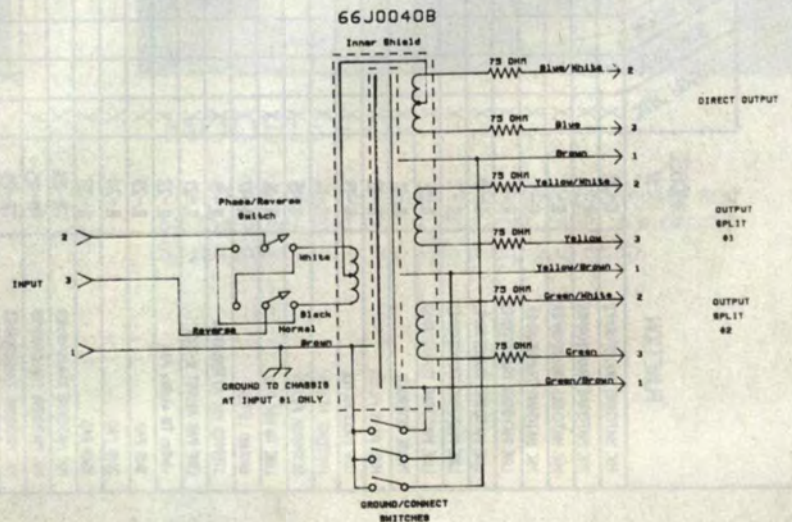
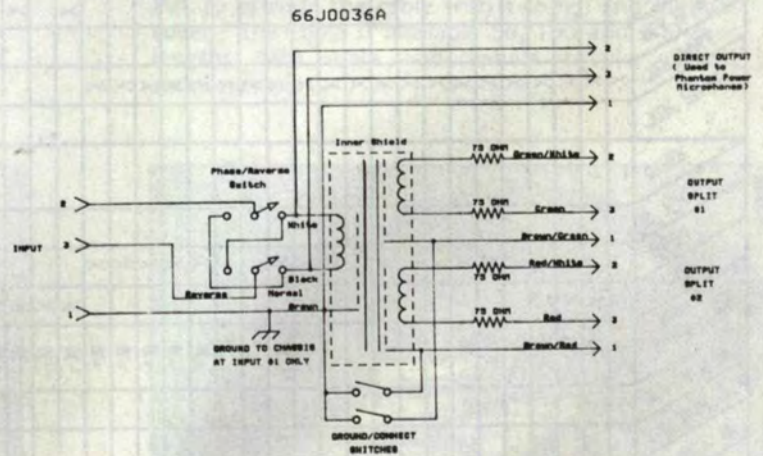

If You Didn't Get This From My Site,
Then It Was Stolen From...

FUNCTION	MODEL #	INPUT SECTION										OUTPUT SECTION										SPECIAL FEATURES																	
		CONNECTORS										IMPEDANCE (ohms)											CONNECTORS										IMPEDANCE (ohms)						
		XLR FEMALE	XLR MALE	1/4" PLUG 75°	1/4" JACK 75°	MINI JACK 75°	POWER LEVEL (dBV)	75° JACK 75°	RCA JACK 75°	750	600	75K	OTHER	XLR FEMALE	XLR MALE	1/4" PLUG 75°	1/4" PLUG 75°	MINI PLUG 75°	RCA JACK 75°	MINI JACK 75°	750	600	75K	60K	OTHER														
MIC MATCHING TRANSFORMER	IL-20	X					-30			X				X							X																		
MIC MATCHING TRANSFORMER	IL-1	X					-30			X				X								X																	
MIC MATCHING TRANSFORMER	IL-2	X					-30			X				X								X																	
MIC MATCHING TRANSFORMER	IL-3	X					-30			X				X								X																	
MIC MATCHING TRANSFORMER	IL-6	X					-30			X				X								X																	
MIC MATCHING TRANSFORMER	IL-19	X					0			X				X								X																	
MIC MATCHING TRANSFORMER	IL-7	X					-20			X				X								X																	
MIC MATCHING TRANSFORMER	IL-9	X					0			X				X								X																	
PHASE REVERSER	IL-11	X								X				X								X																	
HIGH PASS FILTER	IL-12	X								X				X								X																	
LOW PASS FILTER	IL-13	X								X				X								X																	
PRESERVE FILTER	IL-14	X								X				X								X																	
RESPONSE FILTER	IL-15	X								X				X								X																	
LINE TO MIC PAD	IL-16	X					+18			X				X								X																	
GROUND LIFTER	IL-17	X								X				X								X																	
STEPPED MIC ATTENUATOR	IL-18	X								X				X								X																	
LINE PAD ADJUST 0-5dB	IL-21	X					+18			X				X								X																	
+4dBm TO +48dBm PAD	IL-22	X					+18			X				X								X																	
3dB PAD	IL-23	X					+18			X				X								X																	
20dB PAD	IL-24	X					+18			X				X								X																	
30dB PAD	IL-25	X					+18			X				X								X																	
MIC MATCHING TRANSFORMER	TR-24	X					-30			X				X								X																	
MIC MATCHING TRANSFORMER	TR-25	X					-30			X				X								X																	
MIC MATCHING TRANSFORMER	TR-19	X					-30			X				X								X																	
MIC MATCHING TRANSFORMER	TR-20	X					-30			X				X								X																	
MIC MATCHING TRANSFORMER	TR-122	X					-30			X				X								X																	
MIC MATCHING TRANSFORMER	TR-123	X					-30			X				X								X																	
MIC MATCHING TRANSFORMER	TR-126	X					0			X				X								X																	
MIC MATCHING TRANSFORMER	TR-127	X					0			X				X								X																	
MIC MATCHING TRANSFORMER	TR-128	X					0			X				X								X																	
MIC MATCHING TRANSFORMER	TR-129	X					0			X				X								X																	
MIC MATCHING TRANSFORMER	TR-130	X					0			X				X								X																	
MIC MATCHING TRANSFORMER	TR-131	X					0			X				X								X																	
MIC MATCHING TRANSFORMER	TR-132	X					-30			X				X								X																	
MIC MATCHING TRANSFORMER	TR-133	X					-30			X				X								X																	
MIC MATCHING TRANSFORMER	TR-135	X					+4			X				X								X																	
MIC MATCHING TRANSFORMER	TR-136	X					+4			X				X								X																	
MIC MATCHING TRANSFORMER	TR-137	X					0			X				X								X																	
MIC MATCHING TRANSFORMER	TR-138	X					-30			X				X								X																	
MIC MATCHING TRANSFORMER	TR-139	X					-30			X				X								X																	
PAD LINE TO LINE	TR-140						+4			X				X								X																	
PAD LINE TO MIC	TR-141						+4			X				X								X																	
LINE LEVEL COMPRESSOR	TR-142						0			X				X								X																	
MIC MATCHING TRANSFORMER	TR-143						-50			X				X								X																	
MIC MATCHING TRANSFORMER	TR-144						-10			X				X								X																	
MIC MATCHING TRANSFORMER	TR-145						-10			X				X								X																	
MIC MATCHING TRANSFORMER	TR-146						-10			X				X								X																	

ALL ABOVE TRANSFORMERS FEATURE BROAD FREQUENCY RESPONSE & LOW DISTORTION. THE IL-SERIES HAVE ISOLATED ELECTRO-STATIC SHIELDS. THE TR-SERIES ARE ENCLOSED IN MU-METAL SHIELDS.

NEW ITEM

TR-SERIES

FEMALE
"XLR"

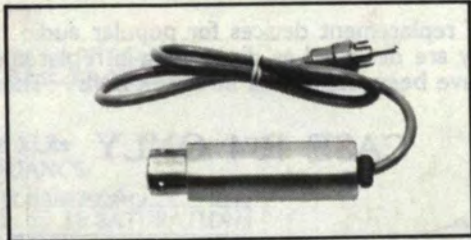

RCA PLUG

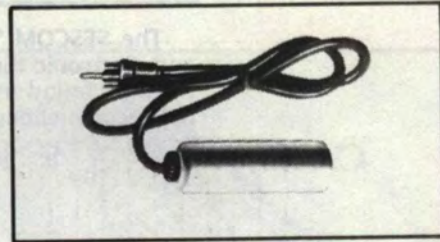

MALE
"XLR"

FEMALE
"XLR"

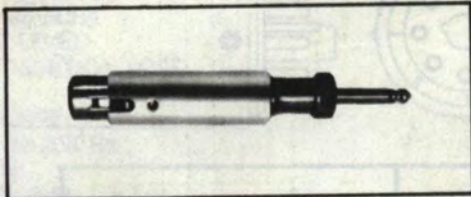

1/4" PHONE PLUG

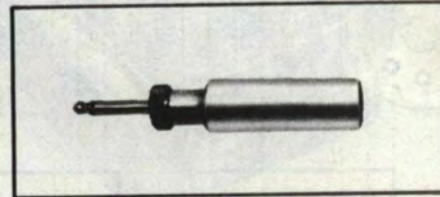

MALE
"XLR"

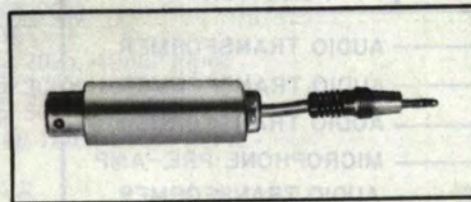

MINI PHONE PLUG

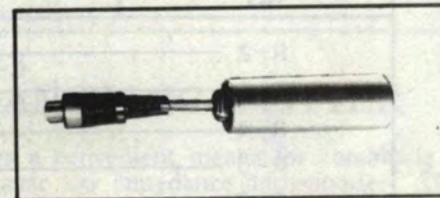

MINI PHONE JACK

RCA JACK

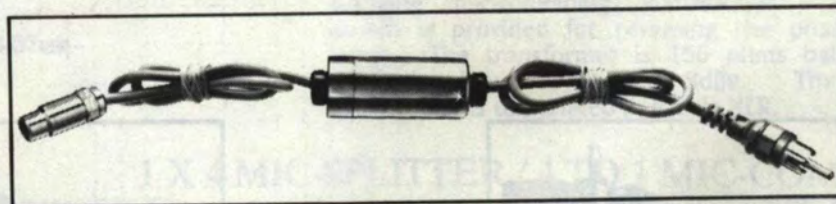

RCA PLUG

SESCOM'S IL and TR series of In-Line devices are designed to solve the common problems of balanced to unbalanced connections or the reverse of that situation. They also provide for matching of levels and impedance. The table on pages 18 and 19 provide all the necessary information to make the proper choice. Make sure you know what the input and output impedance levels and connectors are in your unit and then use the chart to make a proper selection.

All In-Line devices are constructed of the finest materials to give the broadest frequency response, lowest distortion and best performance possible.

IL-SERIES

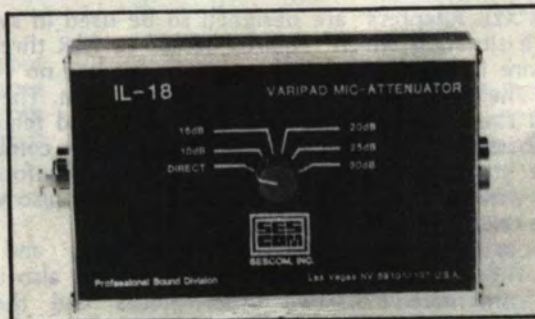
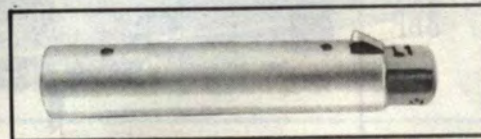
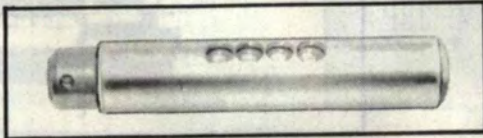

REPLACEMENT SERIES

The SESCOM "R-LINE" is a series of replacement devices for popular audio transformers and electronic function modules. They are designed as direct plug-in replacements. All the features found in the original units have been duplicated in the "R-LINE". These units are not recommended for new designs.

CASE R-2, R-3, R-5, R-8

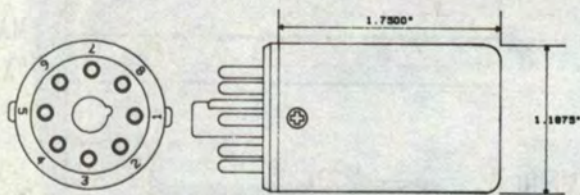

CASE R-4 ONLY

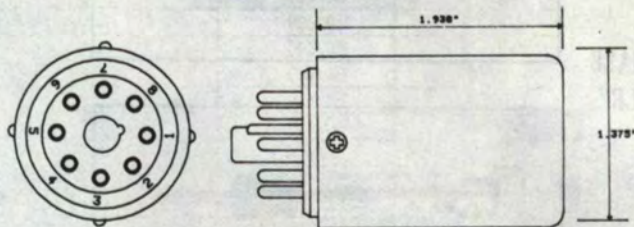

SESCOM MODEL NO.	ORIGINAL MANUFACTURERS MODEL NO.	FUNCTION
R-2	ALTEC 15095A	AUDIO TRANSFORMER
R-3	ALTEC 15335A	AUDIO TRANSFORMER
R-4	ALTEC 15356A	AUDIO TRANSFORMER
R-5	ALTEC 1588B	MICROPHONE PRE-AMP
R-8	BGW 0900-9250	AUDIO TRANSFORMER

"XLR" ADAPTERS

XLR F-2BP

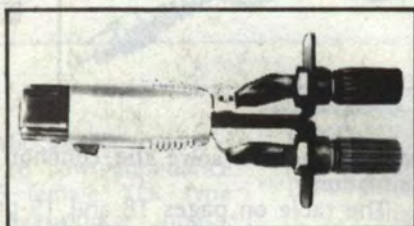

XLR M-2BP

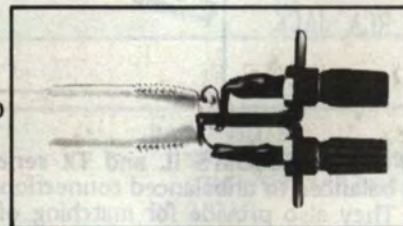

XLR F-3BP

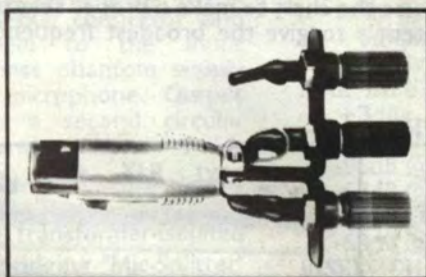

XLR M-3BP

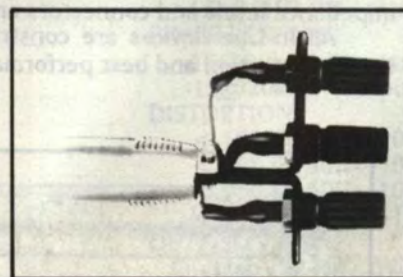

The new SESCOM "XLR Adapters" are designed to be used in systems where the user is faced with a situation which requires access to XLR three pin connectors but the incoming wire has no connectors and the user has no time to install the proper connectors. The "XLR Adapters" answer that problem. They are available in four configurations. They consist of two versions, male and female XLR and two and three binding posts. That gives you, the user, all possible combinations used in the field. These are great devices to carry in your kit for unforeseen occurrences that always happen when they are least expected. They are also valuable for truck systems, to interface teleco.

The banana jacks are color coded RED, BLACK, and GREEN, using industry standards. The XLR male and female jacks are also industry standard. The assembly is constructed of two steel pieces and the proper jacks.

GENERAL PURPOSE TRANSFORMERS

IMPEDANCE CHART

PRIMARY IMPEDANCE (Ohms)	SECONDARY IMPEDANCE (Ohms)	NUMBER OF SECONDARY WINDINGS	REF. 600 Ohms POWER LEVEL	MAGNETIC SHIELDING	SCHEMATIC	CASE STYLE	MODEL #
18.75/75	150/600	1	+18	2	3	C	MI-45
18.75/75	150/600	1	+18	3	7	M	MI-75
18.75/75	150/600	1	+30	2	3	D	MI-46
18.75/75	150/600	1	+30	3	7	N	MI-83
150/600	150/600	1	+18	2	3	C	MI-12
150/600	150/600	1	+18	3	7	M	MI-72
150/600	150/600	1	+30	2	3	D	MI-18
150/600	150/600	1	+30	3	7	N	MI-80
150/600	150/600	1	+18	2	4	C	MI-14
150/600	150/600	1	+18	3	8	M	MI-73
150/600	150/600	1	+30	2	4	D	MI-20
150/600	150/600	2	+30	3	8	N	MI-81
150/600	600	2	+18	2	4	C	MI-43
150/600	600	2	+18	3	8	M	MI-74
150/600	600	2	+30	2	4	D	MI-44
150/600	600	4	+30	3	8	N	MI-82
150/600	600	4	-10	1	1	B	MI-8
150/600	600	4	-10	1	1	F	MI-31
150/600	600	4	-10	2	1	I	MI-53
150/600	600	1	-10	4	5	L	MI-67
150/600	600	1	+4	1	1	F	MI-88
150/600	600	1	+4	2	1	I	MI-93
150/600	600	1	+18	3	1	O	MI-97
150/600	600	1	+30	3	1	O	MI-100
150/600	5K	1	-10	1	1	B	MI-102
150/600	5K	1	-10	1	1	F	MI-106
150/600	5K	1	-10	2	1	I	MI-109
150/600	5K	1	-10	4	5	L	MI-111
150/600	5K	1	+18	2	1	C	MI-103
150/600	5K	1	+18	3	5	M	MI-112
150/600	5K	1	+30	2	1	D	MI-104
150/600	5K	1	+30	3	5	N	MI-113
150/600	15K	1	-10	1	1	B	MI-5
150/600	15K	1	-10	1	1	F	MI-26
150/600	15K	1	-10	2	1	I	MI-50
150/600	15K	1	-10	4	5	L	MI-64
150/600	15K	1	+4	1	1	F	MI-85
150/600	15K	1	+4	2	1	I	MI-90
150/600	15K	1	+18	1	1	C	MI-9
150/600	15K	1	+18	3	5	M	MI-69
150/600	15K	1	+18	3	1	O	MI-96
150/600	15K	1	+30	2	1	O	MI-15
150/600	15K	1	+30	3	5	N	MI-77
150/600	15K	1	+30	3	1	O	MI-99
3.75K/15K	15K/60K	1	+18	2	3	C	MI-13
3.75K/15K	15K/60K	1	+18	3	7	M	MI-76
3.75K/15K	15K/60K	1	+30	2	3	D	MI-19
3.75K/15K	15K/60K	1	+30	3	7	N	MI-84
15K	15K/60K	1	-10	1	2	F	MI-32
15K	15K/60K	1	-10	2	2	B	MI-22
15K	15K/60K	1	-10	2	2	I	MI-54
15K	15K/60K	1	-10	4	6	L	MI-68
15K	15K/60K	1	+4	1	2	F	MI-89
15K	15K/60K	1	+4	2	2	I	MI-94
15K	15K/60K	1	+18	3	2	O	MI-95
15K	15K/60K	1	+30	3	6	O	MI-98
15K	15K	1	+14	2	10	R	MI-115
150	5K	1	-20	2	11	R	MI-116
600	600	1	0	2	10	R	MI-117
600	600	1	+18	4	9	S	MI-118
150	600	1	+24	4	9	S	MI-119

MAGNETIC SHIELDING: 1 - 60dB, 2 - 30dB, 3 - 10dB, 4 - NONE
 FREQUENCY RESPONSE: +/-1dB, 20-20KHz
 DISTORTION: LESS THAN 0.2% AT 30Hz
 (ALL ARE WITH ELECTROSTATIC SHIELD)

MODEL #	SCHEMATIC		PRIMARY				SECONDARY								ELECTRO-STATIC SHIELD M
	PINS	LEADS	A	B	C	D	E	F	G	H	I	J	K	L	
MI-5	1	X	4	2	3	1	6	7							8
MI-8	1	X	4	2	3	1	6	7							8
MI-9	2	X	4	2	3	1	10	11							12
MI-12	3	X	4	2	3	1	8	10	9	11					12
MI-13	3	X	4	2	3	1	8	10	9	11					12
MI-14	4	X	4	2	3	1	5	7	6	8	9	11	10	12	CASE
MI-15	2	X	4	2	3	1	10	11							12
MI-18	3	X	4	2	3	1	8	10	9	11					12
MI-19	3	X	4	2	3	1									12
MI-20	4	X	4	2	3	1	5	7	6	8	9	11	10	12	CASE
MI-22	2	X	2			1	4	6	5	7					8
MI-28	1		X	Y	BL	0	BLK	G/W	G						BR
MI-31	1		X	Y	BL	0	BLK	R/W	R						BR
MI-32	2		X	Y			BLK	G/W	G	R/W	R				BR
MI-43	4	X	4	2	3	1	5	6	7	8	9	10	11	12	CASE
MI-44	4	X	4	2	3	1	5	6	7	8	9	10	11	12	CASE
MI-45	3	X	4	2	3	1	8	10	9	11					12
MI-46	3	X	4	2	3	1	8	10	9	11					12
MI-50	1		X	Y	BL	0	BLK	G/W	G						BR
MI-53	1		X	Y	BL	0	BLK	R/W	R						BR
MI-54	2		X	Y			BLK	G/W	G	R/W	R				BR
MI-64	5		X	Y	BL	0	BLK	G/W	G						BR
MI-67	5		X	Y	BL	0	BLK	R/W	R						BR
MI-68	6		X	Y			BLK								BR
MI-69	5		X	Y	BL	0	BLK	G/W	G						BR
MI-72	7		X	Y	BL	0	BLK	G/W	G	R/W	R				BR
MI-73	8		X	Y	BL	0	BLK	Y/W	Y	BL/W	BL	G/W	G	R/W	R
MI-74	8		X	Y	BL	0	BLK	Y/W	Y	BL/W	BL	G/W	G	R/W	R
MI-75	7		X	Y	BL	0	BLK	R/W	R	G/W	G				BR
MI-76	7		X	Y	BL	0	BLK	R/W	R	G/W	G				BR
MI-77	5		X	Y	BL	0	BLK	G/W	G						BR
MI-80	7		X	Y	BL	0	BLK	G/W	G	R/W	R				BR
MI-81	8		X	Y	BL	0	BLK	Y/W	Y	BL/W	BL	G/W	G	R/W	R
MI-82	8		X	W	V	0	BLK	Y/W	Y	BL/W	BL	G/W	G	R/W	R
MI-83	7		X	Y	BL	0	BLK	G/W	G	R/W	R				BR
MI-84	7		X	Y	BL	0	BLK	R/W	R	G/W	G				BR
MI-85	1		X	Y	BL	0	BLK	G/W	G						BR
MI-88	1		X	Y	BL	0	BLK	R/W	R						BR
MI-89	2		X	Y			BLK	G/W	G	R/W	R				BR
MI-90	1		X	Y	BL	0	BLK	G/W	G						BR
MI-93	1		X	Y	BL	0	BLK	R/W	R						BR
MI-94	2		X	Y			BLK	G/W	G	R/W	R				BR
MI-95	2	X	2			1	4	6	5	7					8
MI-96	1	X	4	2	3	1	6	7							8
MI-97	1	X	4	2	3	1	6	7							8
MI-98	2	X	2			1	4	6	5	7					8
MI-99	1	X	4	2	3	1	6	7							8
MI-100	1	X	4	2	3	1	6	7							8
MI-102	1	X	4	2	3	1	6	7							8
MI-103	1	X	4	2	3	1	10	11							12
MI-104	1	X	4	2	3	1	10	11							12
MI-106	1		X	Y	BL	0	BLK	G/W	G						BR
MI-109	1		X	Y	BL	0	BLK	G/W	G						BR
MI-111	5		X	Y	BL	0	BLK	G/W	G						BR
MI-112	5		X	Y	BL	0	BLK	G/W	G						BR
MI-113	5		X	Y	BL	0	BLK	G/W	G						BR
MI-115	10	X	4	6			3	1							M
MI-116	11	X	4	6			3	2							1
MI-117	10	X	4	6			3	1							1
MI-118	9	X	4	1			8	5							1
MI-119	9	X	4	1			8	5							1

CASE STYLE "B"

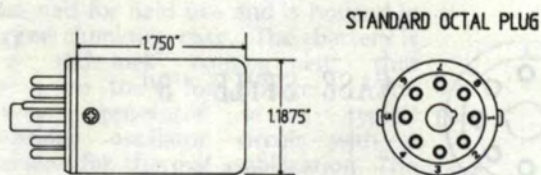

CASE STYLE "C"

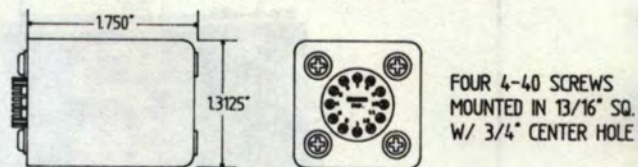

CASE STYLE "D"

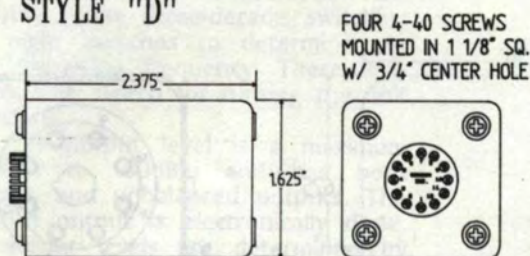

CASE STYLE "F"

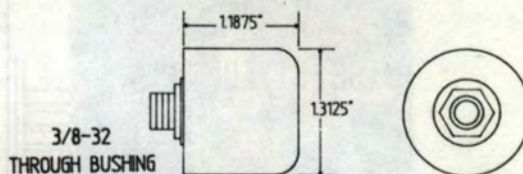

CASE STYLE "I"

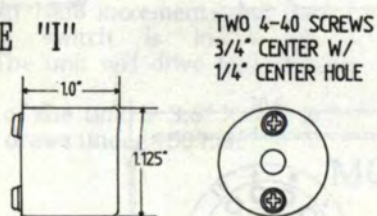

CASE STYLE "O"

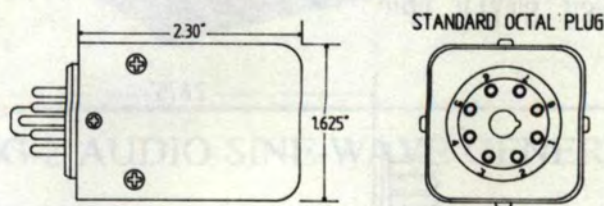

CASE STYLE "R"

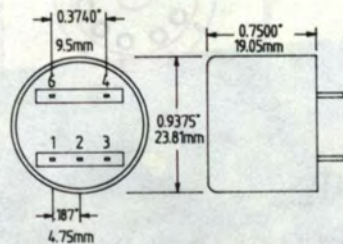

CASE STYLE "L" "M" "N"

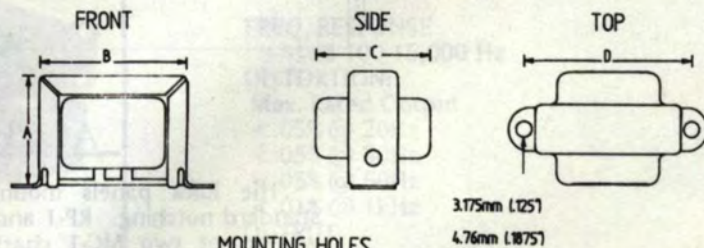

CASE STYLE "S"

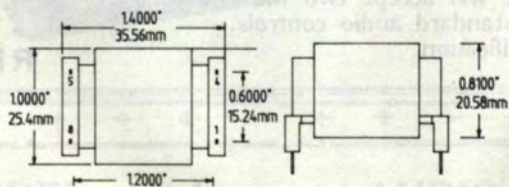

MOUNTING HOLES

CASE STYLE	A	B	C	D
L	19.05mm (1.750)	26.98mm (1.0625)	19.05mm (1.750)	33.33mm (1.3125)
M	28.57mm (1.125)	36.51mm (1.4375)	31.75mm (1.250)	44.45mm (1.750)
N	42.86mm (1.6875)	42.86mm (1.6875)	33.33mm (1.3125)	50.80mm (2.0)

SCHEMATICS

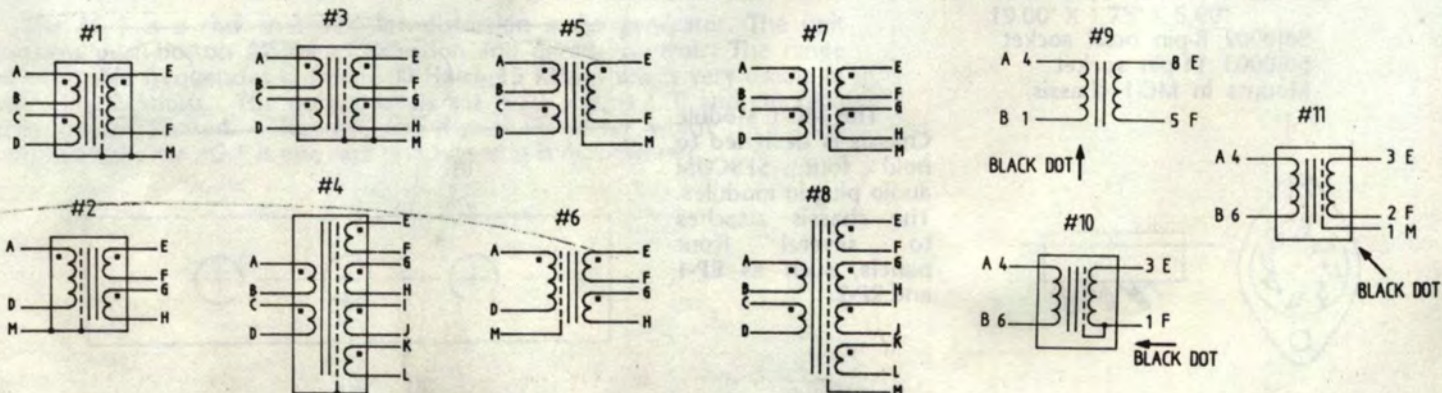

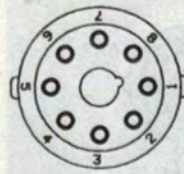
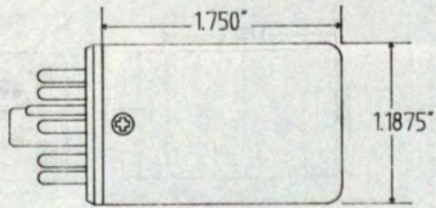

CASE STYLE "B"

CASE STYLE "O"

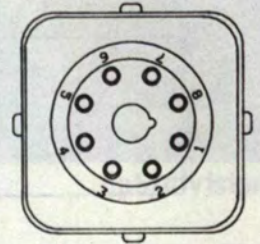
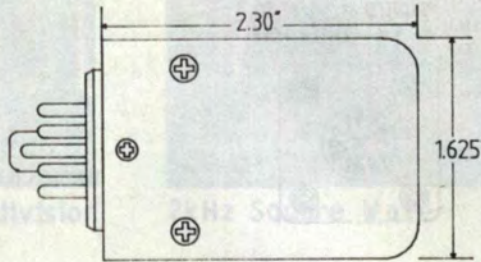

CASE STYLE "P"

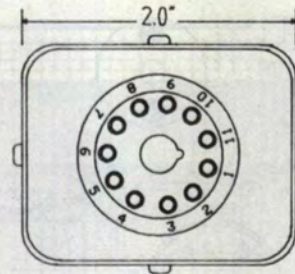
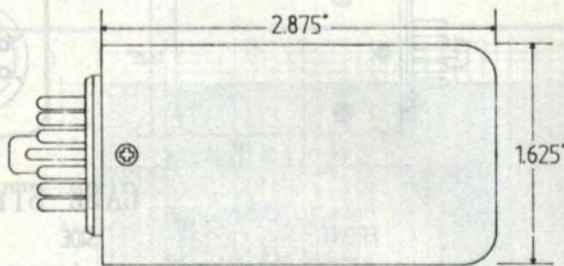

ACCESSORIES

The Rack panels mount on standard 19" relay racks with standard notching. RP-1 and RP-2 are 1 3/4" high X 19" wide. RP-1 will accept two MC-1 chassis only. RP-2 will accept two MC-1 chassis and has eight 3/8" dia. holes for standard audio controls. RP-2 has silk screened legends for easy identification.

RP-1



RP-2



SOCKETS

58J0002 8-pin octal socket
 58J0003 11-pin socket
 Mounts in MC-1 chassis

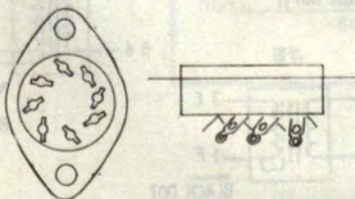

The MC-1 Module Chassis is designed to hold four SESCOM audio plug-in modules. The chassis attaches to several front panels, such as RP-1 and RP-2.

MODULE CHASSIS

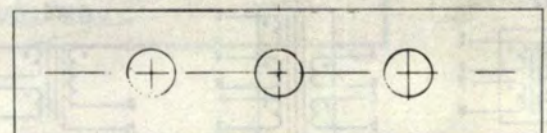
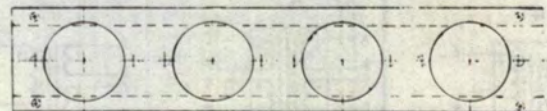

MIC-PREAMPS

MIC-4

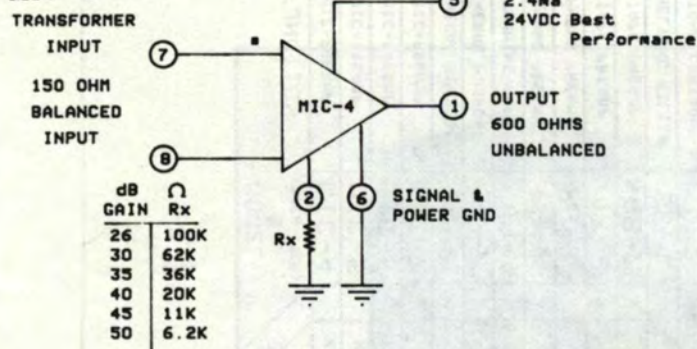

TRANSFORMER INPUT
WILL POWER PHANTOM MICS'
150 OHM BALANCED INPUT

MIC-5

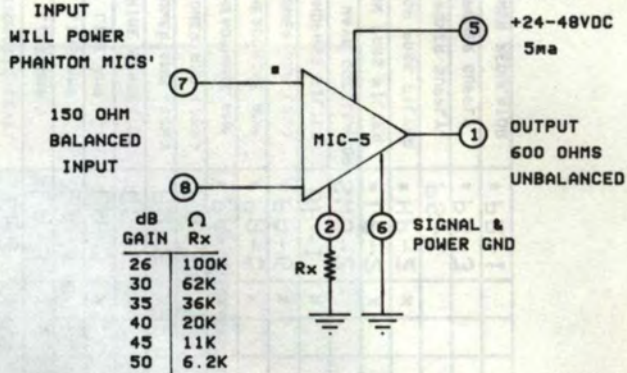

MIC-6

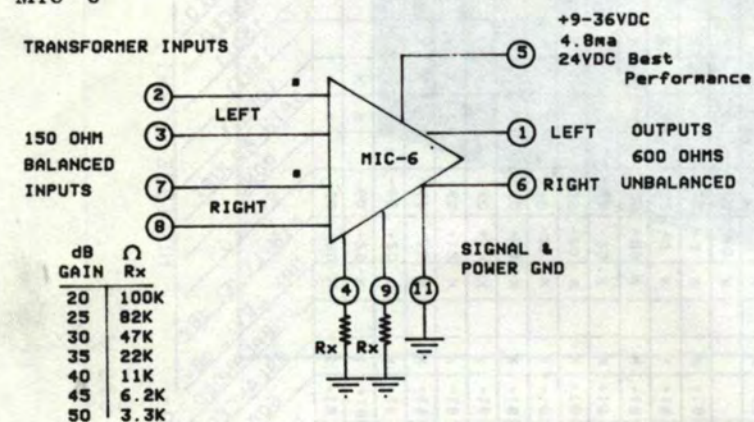

MIC-7

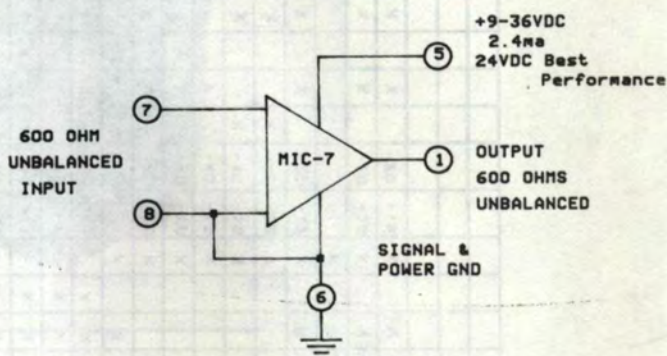

GENERAL PURPOSE PRE-AMPS

SA-2

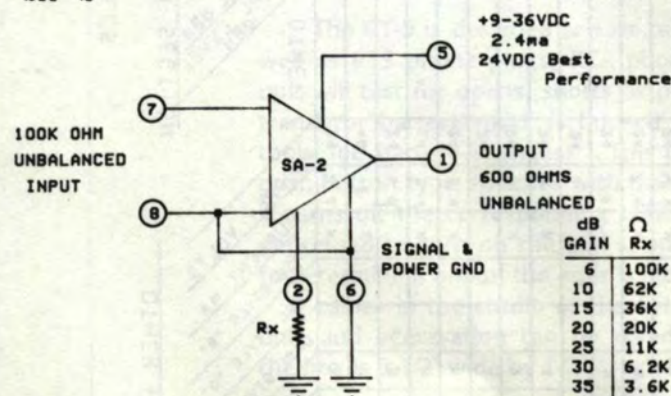

SA-3

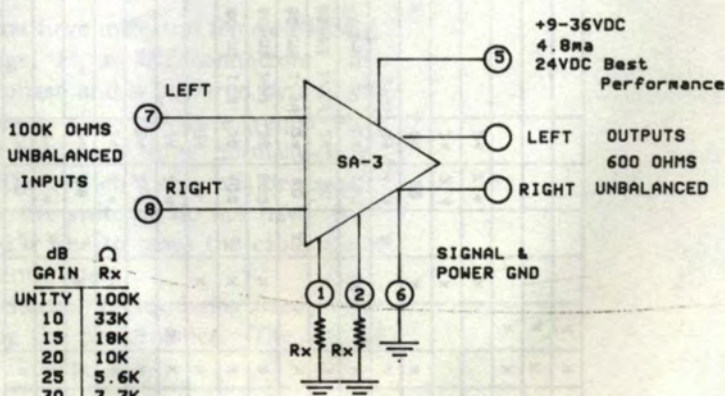

SA-4

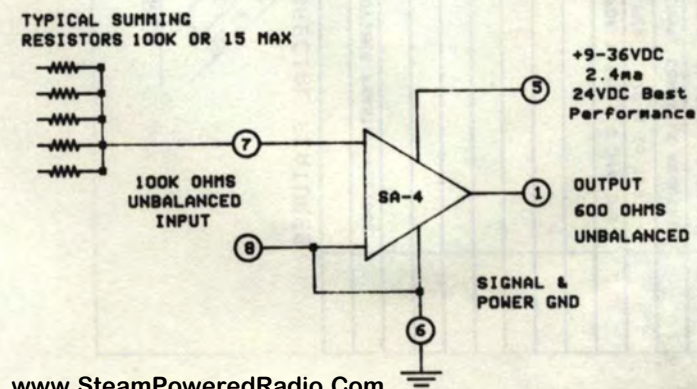

PH-2

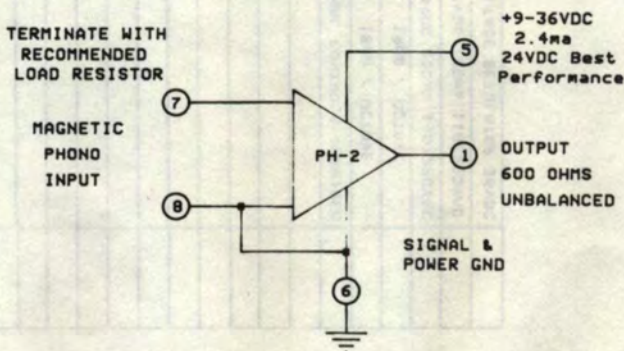

PH-3

TERMINATE WITH RECOMMENDED LOAD RESISTOR

STEREO MAGNETIC PHONO INPUTS

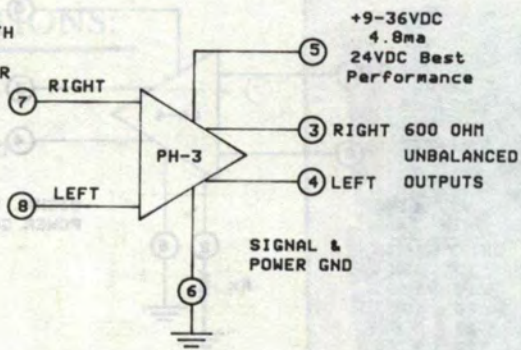

NAB-2/NAB-3

TERMINATE WITH RECOMMENDED LOAD RESISTOR

TAPE HEAD HI-Z

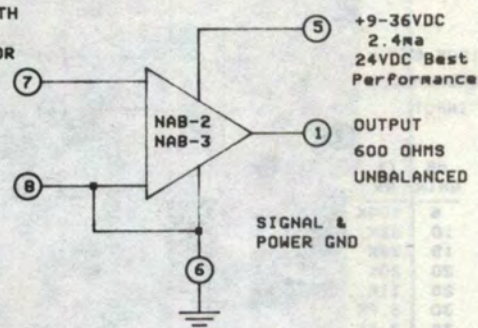

SF-1

INPUT 100K OHMS UNBALANCED

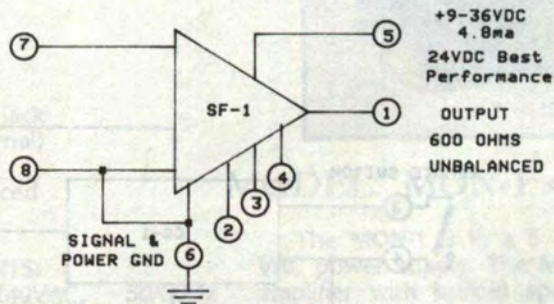

HIGH FREQUENCY

$$C = \frac{15.9 \times 10^{-6}}{f}$$

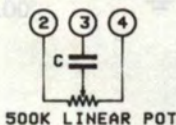

LOW FREQUENCY

$$C = \frac{15.9 \times 10^{-6}}{f}$$

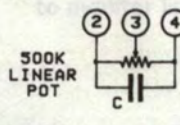

TC-2

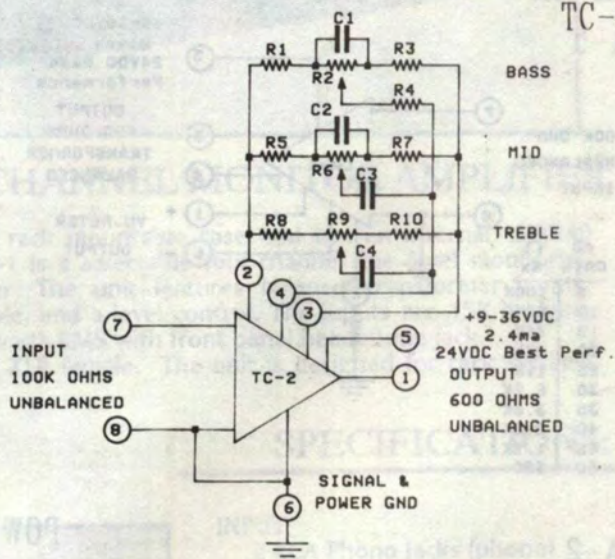

LM-2

100K OHMS UNBALANCED INPUT

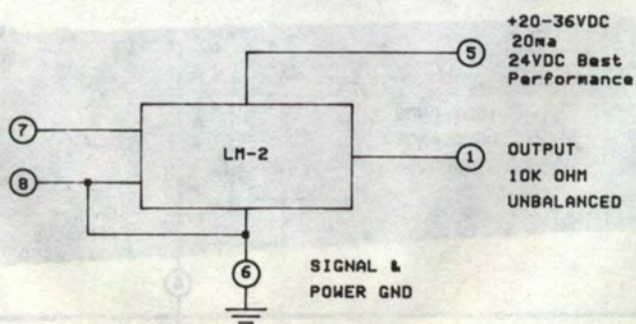

PN-1

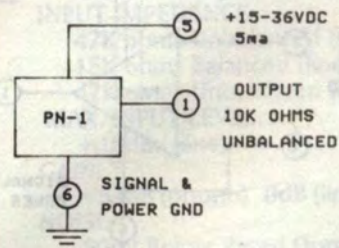

VU-1

15K OHMS UNBALANCED INPUT

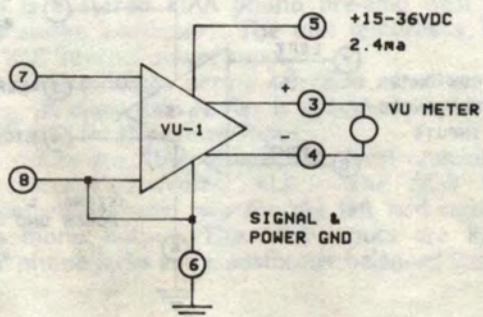

C-2

100K OHMS UNBALANCED INPUT

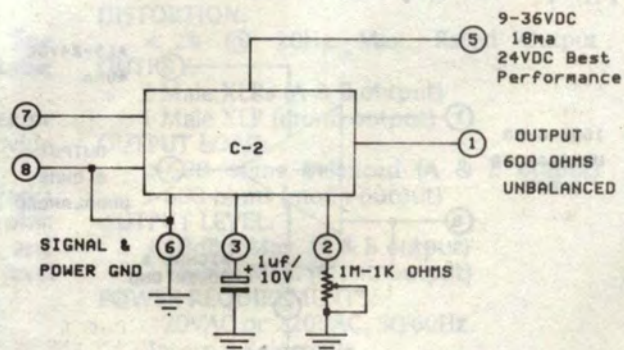

If You Didn't Get This From My Site,
 Then It Was Stolen From...

LA-3

100K OHM UNBALANCED INPUT

dB GAIN	Ω Rx
6	100K
10	62K
15	36K
20	20K
25	11K
30	6.2K
35	3.6K
40	2.0K
45	1.1K
50	620

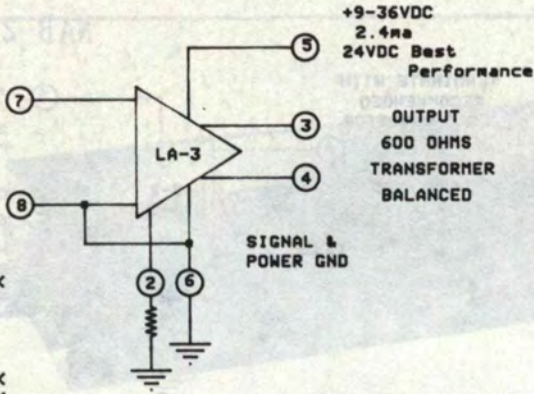

OUTPUT 600 OHMS TRANSFORMER BALANCED

+9-36VDC
2.4ma
24VDC Best Performance

LA-4

INPUT 15K OHMS TRANSFORMER BALANCED

UNITY	Ω Rx
10	33K
15	18K
20	10K
25	5.6K
30	3.3K
35	1.8K
40	1.0K

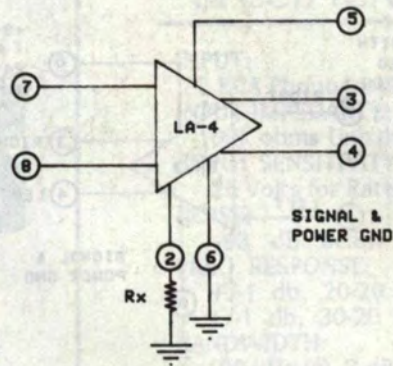

+9-36VDC
2.4ma
24VDC Best

OUTPUT 600 OHMS TRANSFORMER BALANCED

LA-5

100K OHM UNBALANCED INPUT

dB GAIN	Ω Rx
6	100K
10	62K
15	36K
20	20K
25	11K
30	6.2K
35	3.6K
40	2.0K
45	1.1K
50	620

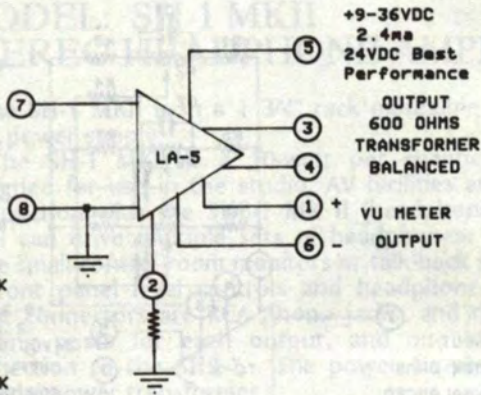

+9-36VDC
2.4ma
24VDC Best Performance

OUTPUT 600 OHMS TRANSFORMER BALANCED

CG-1

REMOTE SWITCH

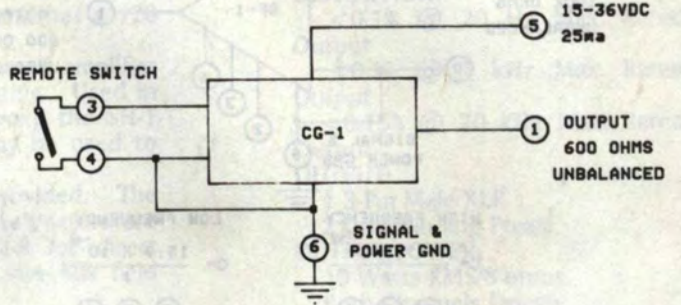

15-36VDC
25ma

OUTPUT 600 OHMS UNBALANCED

POWER AMPLIFIERS

PA-2

100K OHMS UNBALANCED INPUT

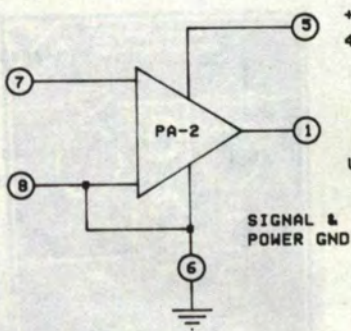

+9-36VDC
400ma

OUTPUT 8 OHMS UNBALANCED

PA-3

100K OHMS UNBALANCED INPUT

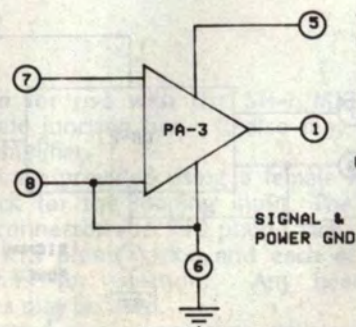

+9-36VDC
800ma

OUTPUT 8 OHMS UNBALANCED

PA-4

100K OHMS UNBALANCED INPUT

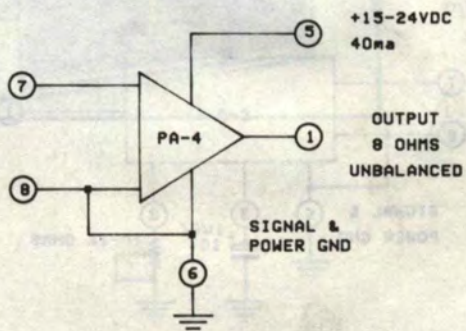

+15-24VDC
40ma

OUTPUT 8 OHMS UNBALANCED

PA-5

100K OHMS UNBALANCED INPUTS

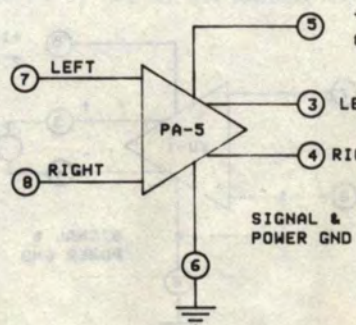

+15-24VDC
80ma

LEFT OUTPUTS 8 OHMS UNBALANCED
RIGHT

PA-6

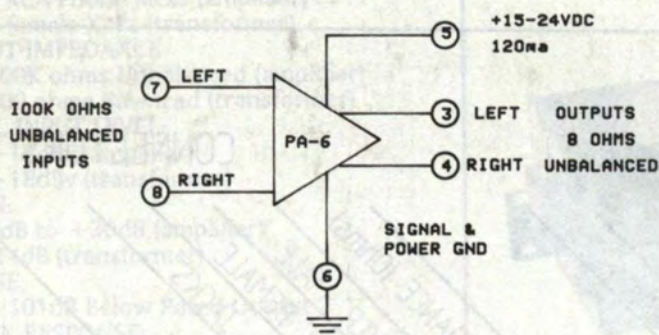

BP-1

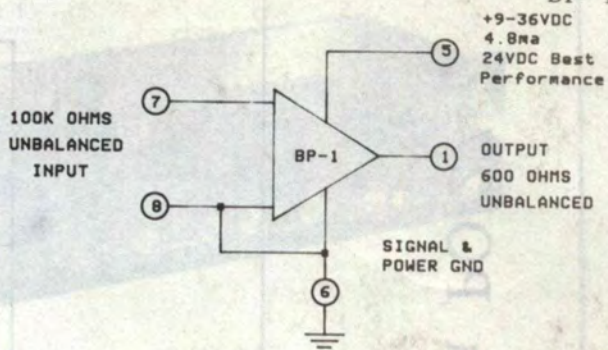

SWO-2

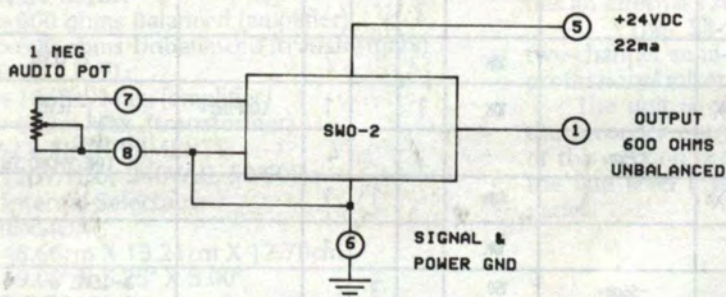

LP-2

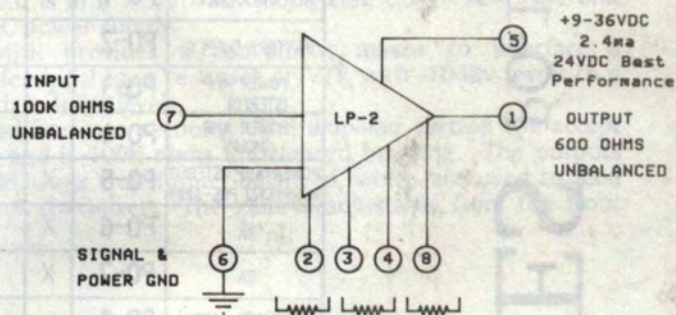

HP-2

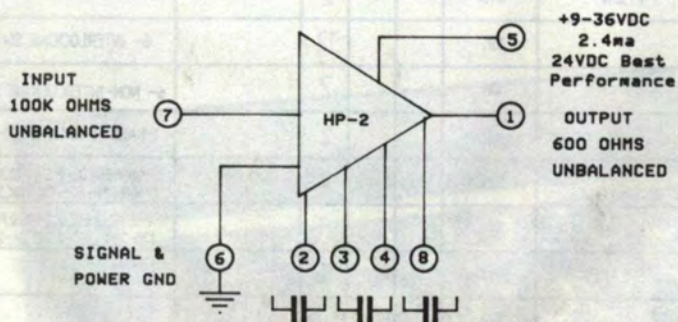

PS-1

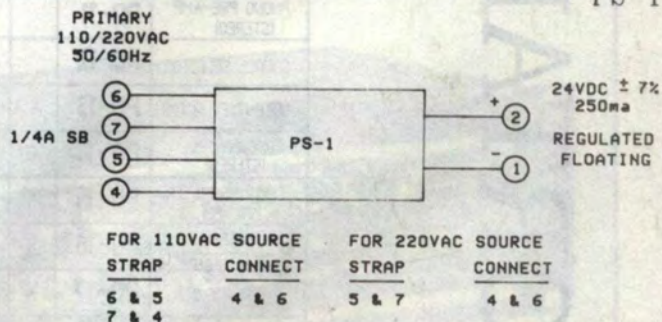

PS-3

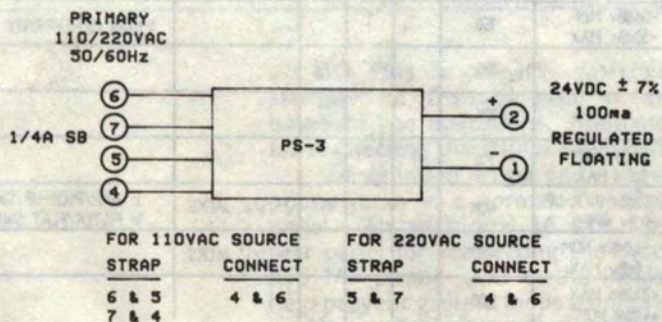

PR-1

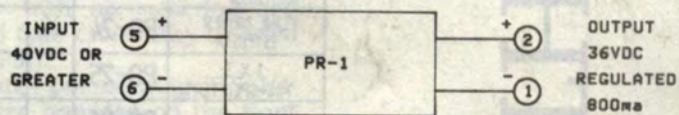

THE PORTABLES PO-1 thru PO-27

		INPUT SECTION												
		LEVEL					CONNECTORS							
		-10dBv 775mv		+4dBm 1.22V			IMPEDANCE (ohms)		XLR* MALE			XLR* FEMALE		RCA JACKS
FUNCTION	MODEL #				OTHER					OTHER		CONTROLS		
AC POWER SUPPLY	PO-1													
BATTERY SUPPLY	PO-2													
POWER AMP (STEREO)	PO-3	X				10K			2			2- LEVEL		
POWER AMP (MONO)	PO-4		X			10K	1	1		LOOPING		1- LEVEL		
POWER AMP (STEREO W/ PHONO PRE-AMP)	PO-5	X			175mv				4			2- LEVEL & 1- LINE/PHONO SWITCH		
DA	PO-6	X	X			600		1	1					
DA	PO-7	X				10K			1					
3-CHANNEL MIXER	PO-8				-56dBv	150		3				3- LEVEL & 3- LOW CUT SWITCHES		
3-CHANNEL MIXER	PO-9				-56dBv	150		3				3- LEVEL & 3- LOW CUT SWITCHES		
AUDIO OSCILLATOR	PO-10													
PHONO PRE-AMP (STEREO)	PO-11				175mv	47K			2					
SOURCE SELECTOR	PO-12					10K			12			6- INTERLOCKING SWITCHES		
OUTPUT SELECTOR	PO-13	X				10K			2			6- NON-INTERLOCKING SWITCHES		
TONE CONTROL (STEREO)	PO-14	X				10K			2			1-BASS, 1-BALANCE, 1-TREBLE		
SHELVING FILTER (STEREO)	PO-15	X				10K			2			1-LOW FREQ. 1-SW (20.100Hz) 1-HIGH FREQ. 1-SW (10K,20KHz)		
PARAMETRIC EQUALIZER(STEREO)	PO-16	X				10K			1			1-LEVEL,1-FREQ.,1-FREQ.RANGE (20-230, 200-2.3K, 2K-23KHz)		
INTERFACE BOX	PO-17	X			SPEAKER	8 10K			1	1-1/4", 1-3/16" & 1-3.5mm JACK				
LINE BALANCE BOX (MONO)	PO-18		X			600	1							
(MONO) OUTPUT BALANCE BOX	PO-19				+21dBm MAX +4dBm NOM	600		1		1/4" STEREO				
MIC ISOLATION BOX (MONO)	PO-20					150		1						
DUAL VU METERS	PO-21	X	X			10K		2				1-SWITCH -10 OR +4 REFERENCE LEVEL		
MIC-LINE DRIVER	PO-22				-56dBv MIN -30dBv MAX	150		1				1-GAIN (SCREWDRIVER ADJUST)		
SUMMING AMP (STEREO)	PO-23	X				10K			12					
LINE DRIVER (STEREO)	PO-24	X				10K			2					
1 X 3 "MIC-SPLITTER"	PO-25				-56dBv NOM 0dBv MAX	150	1							
PASSIVE DIRECT BOX	PO-26				-20dBv PICK-UP +6dBv AMP	60K				2- 1/4" JACKS		1- AMP/PICK-UP SWITCH 1- FILTER/FLAT SWITCH		
ACTIVE DIRECT BOX	PO-27				-40dBv NOM 0dBv MAX	490K				2- 1/4" JACKS				
LINE LEVEL SPLITTER	PO-28				+21dBm MAX +4dBm NOM	600		1						

THE PORTABLES PO-28 thru PO-54

INPUT SECTION

FUNCTION	MODEL #	LEVEL			CONNECTORS			CONTROLS
		-10dBv 775mV	+4dBm 122V	OTHER	IMPEDANCE (ohms)	"XLR" MALE	"XLR" FEMALE	
				OTHER				
HEADPHONE LISTEN BOX	PO-29			+4dBm LINE -56dBv MIC	600	1		1-LEVEL, 1- ON/OFF, 1- MIC/LINE SWITCH
PAD BOX 0-65dB	PO-30			+21dBm MAX	600	1		6- PUSH BUTTON SWITCHES
REMOTE HEADPHONE BOX	PO-31			4 WATTS/CHANNEL	8		2-1/4" STEREO JACKS	2- LEVEL
60dB PRECISION GAIN BOX	PO-32			+20dBm MAX -40dBv MIN	600	1		2- ROTARY
STEREO COMBINER	PO-33	X			10K	2		
STEREO AUTOMATIC LEVEL CONTROL	PO-34			-40dBv +12dBv	10K	2		
STEREO FAST ATTACK LIMITER	PO-35	X			10K	2		
STEREO NOISE GATE & VCA	PO-36	X			10K	2		GAIN (INPUT)
PINK NOISE GENERATOR	PO-37							
"XLR" TURN-AROUND BOX	PO-38					2 2		
UNBALANCED TURN-AROUND BOX	PO-39					2	2-1/4" STEREO & 2-3.5mm JACKS	
MONO, FIVE-BAND GRAPHIC EQUALIZER	PO-40	X			10K	1		5- BOOST OR CUT AT 60, 240, 1K, 3K, & 10KHz
AC POWERED, SEMI-PRO MIC-LINE DRIVER	PO-41			-56dBv MIN -30dBv MAX		1		1- GAIN (SCREWDRIVER ADJUST)
PHANTOM AC POWER SUPPLY	PO-42			-56dBv MIN -10dBv MAX	150	2		
RACK MOUNTING ACCESSORY	PO-43							
TRANSFORMER ASSEMBLY	PO-44	X	X		15K	2	SCREW TERMINALS	
STEREO HEADPHONE LISTEN BOX	PO-45	X	X				1/4" STEREO	1-LEVEL, 1-ON/OFF, 1- 10/+4
MONO ECHO EFFECTS BOX	PO-46	X			10K	1		ECHO MIX
MONO REVERBERATION	PO-47	X			10K	1		
TONE-BURST GENERATOR	PO-48	X			10K	1		1- 2.4, 8.16, & ON/OFF
PORTABLE SOUND LEVEL METER	PO-49			SPECIAL MICROPHONE				
VIDEO DA	PO-50			1V P-P	75		BNC	
3-WAY ACTIVE CROSSOVER	PO-51	X			10K	1		
FEEDBACK ELIMINATOR	PO-52	X			10K	1		
2 X 1 MIC-COMBINER	PO-53			-56dBv NOM 0dBv MAX	150	2		
3-CHANNEL LINE AMPLIFIER	PO-54	X			10K	4		4 LEVEL
AC POWERED STEREO LINE DRIVER	PO-55	X			10K	2		

OUTPUT SECTION

		LEVEL		CONNECTORS			POWER REQUIREMENTS	
		-10dBv 775mv	+4dBm 1.22v	IMPEDANCE (ohms)	XLR* MALE	XLR* FEMALE	RCA JACKS	OTHER
		OTHER					OTHER	SPECIAL FEATURES
		1/4 W.	8					1-9 VOLT BATTERY
		+21dBm MAX		1				6 PADS W/ 1,2,4,8,10 & 20 INCREMENTS
								STEREO CONTROL BOX FOR HEADPHONES
				1				X X
X			10K		3			STEREO IN, STEREO & MONO OUT
X			10K		2			X X
X			10K		2			X X
X			10K		2			INPUT GAIN CONTROL, GATE SWITCH
	X		600		1		1-1/4" JACK	2-9 VOLT BATTERIES
X			10K		1			X X
X			10K		1		1-1/4" JACK	120 VAC
		-56dBv MIN -10dBv MAX	150	2				SUPPLIES 48V TO MIC'S BALANCED TRANSFORMERS
								MOUNTS UP TO THREE PORTABLES IN ONE RACK SPACE
X	X		600		3		SCREW TERMINALS	INTERFACE BOX FOR PO-33 TO BALANCE INPUTS & OUTPUTS
		8						STEREO JACKS 1-1/4" & 1-MINI
X			10K		1			X X
X			10K		1			X X
X			10K		3			X X
								VU METER WITH LEVEL SWITCH SLOW/FAST FLAT/A WEIGHTED
		1V P-P	75				3 OUTPUTS	X X
X			10K		3		3 OUTPUTS	CROSSOVER POINTS, CHANGEABLE
X			10K		1			X X
			150	1				
X					1			X X
	X			2				120 VAC

**MODEL: PO-1
AC POWER SUPPLY**

The PO-1 is an AC Power Supply, 117 VAC 60 Hz, with a fixed line cord, fuse, on-off switch, and a power LED. Output voltages are +/- 18VDC 50ma, +24VDC 350ma. There are four 5-pin DIN sockets for output.

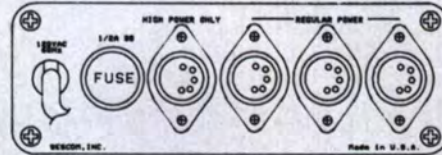
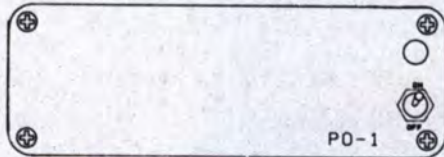

**MODEL: PO-2
BATTERY SUPPLY**

The PO-2 is a DC Power Supply which uses four transistor nine volt batteries (not supplied); +/- 18VDC 175 ma/hr (alkaline batteries). It has two 5-pin DIN sockets for the outputs. Two PO-2's can be daisy-chained for more current capability. Batteries are enclosed in slide-lock compartments for easy field changing with no tools.

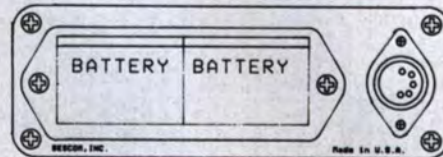
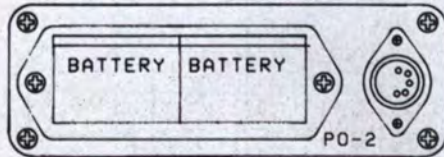

**MODEL: PO-3
STEREO AMPLIFIER**

The PO-3 is a stereo power amplifier with two watts per channel. There are two front panel volume controls and 1/4" and 3.5mm stereo headphone jacks. The rear panel has two RCA phono jacks for input and two 1/4" jacks for speaker connection. The unit has inputs of 10K ohms, -10dBv level for full output of 2 watts into 8 ohms. The PO-1 is required to power the unit. It features low distortion and full frequency response.

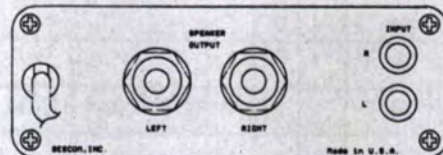
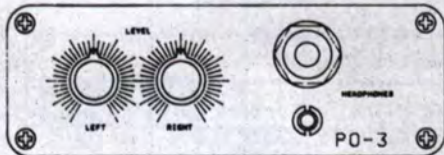

**MODEL: PO-4
MONO AMPLIFIER**

The PO-4 is a bridged 4 watt mono power amplifier. It has a front panel volume control. The rear panel has male and female XLRs for the input which is +4dBm 10K ohms bridging, and a 1/4" phone jack for the output. The PO-1 is required to power the unit. It features low distortion and full frequency response.

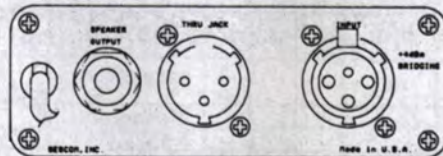

**MODEL: PO-5
STEREO AMPLIFIER
WITH PHONO PRE-AMP**

The PO-5 is a stereo power amplifier with 2 watts per channel with built-in phono pre-amp and line inputs which are front panel selectable. There are front panel volume controls for left and right, a switch to select between phono and line function, and 1/4" stereo & 3.5mm stereo headphone jacks for private listening. The rear panel has four RCA phono jacks for phono and line and two 1/4" jacks for speaker connection. The phono input has 47K ohm load resistors and RIAA pre amp. The line input is 10K ohms -10dBv designed to be used with tape recorders etc. The output will drive 8 ohm devices with 2 watts of undistorted output. The PO-1 is required to power unit. It features low distortion and full frequency response.

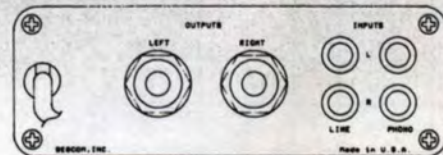
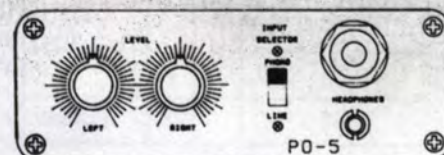

The PO-6 is a 1 X 3 Audio DA for interfacing professional and semi-professional audio equipment. The unit features electronic balanced input and output. The front panel has two RCA phono jacks. One jack has a -10dBV 10K ohm input to drive the three outputs and the other jack is used as an output jack. The rear panel has one female "XLR" for input and three male XLRs for outputs. A power cord is attached. The outputs are capable of driving a 600 ohm load to +18dBm with low distortion. The unit can be powered with the PO-1 or PO-2 power supplies. The PO-6 can interface the +4dBm or -10dBV by using the proper input jacks to the +4dBm outputs. The unit can accept a +4dBm input and feed the PO-7 1 X 6 DA which is all -10dBV.

MODEL: PO-6
1 X 3 PRO DA

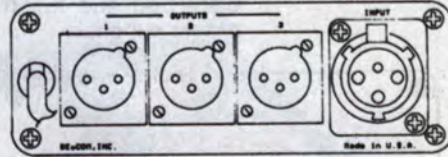
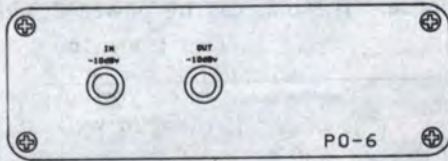

The PO-7 is a 1 X 6 Audio DA for one -10dBV input to six -10dBV outputs. The rear panel has two RCA jacks, one for input and the other can be used to loop another device such as PO-7 DA or PO-4 mono power amplifier etc. There are six RCA phono jacks for outputs to drive any source which requires -10dBV 10K ohms. There is a power cord attached to the unit. Each output is driven by a separate amplifier to give it isolation. The unit features low distortion and frequency response. The unit requires the PO-1 or PO-2 power supplies.

MODEL: PO-7
1 X 6 SEMI-PRO DA

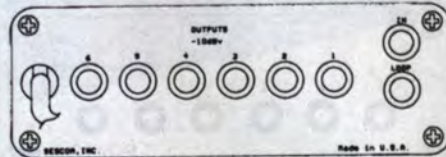

The PO-8 is a three-channel mixer that can accept any microphone. The inputs are electronically balanced in and are bridging. There are three low cut filters for low frequency roll off. The front panel also has a mini VU meter and headphone jack. The rear panel has three female XLRs, one RCA phono jack for line output and one 3.5mm jack for mic level output. There is a power cord attached. It features low distortion and full frequency response. The unit requires either the PO-1 or PO-2 power supplies.

MODEL: PO-8
3-CHANNEL SEMI-PRO
MIC MIXER

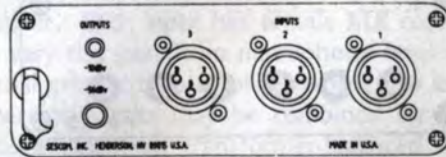
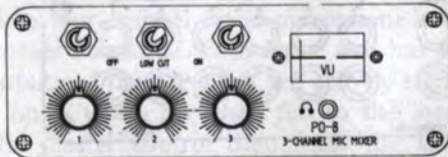

The PO-9 is a three-channel mixer that can accept any microphone. The inputs are electronically balanced in and are bridging. There are three low cut filters for low frequency roll off. The front panel also has a mini VU meter and headphone jack, on-off switch and power LED. The output is electronically balanced +4dBm. The rear panel has three female XLRs for the inputs, and the output is a male XLR +4dBm. The unit requires two 9 volt alkaline batteries (not supplied). Kodak lithium batteries are preferable for longer use life.

MODEL: PO-9
3-CHANNEL PRO
MIC MIXER

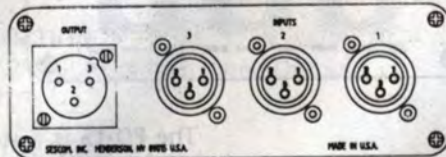
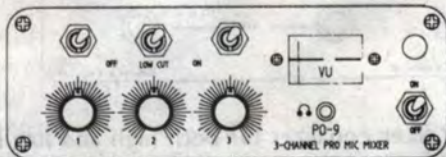

The PO-10 is a sine wave oscillator with fixed frequency and three separate outputs. The unit has +4dBm with male XLR, a -10dBV out RCA phono jack and -56dBm 3.5mm jack output. There is a frequency adjust knob on the front panel which allows a decade of adjustment. The front panel also has an on-off switch and a power LED. The unit requires a nine transistor battery (not supplied). The Kodak lithium battery is preferable for longer use life.

MODEL: PO-10
SINE WAVE OSCILLATOR

MODEL: PO-11
STEREO PHONO
PRE-AMP

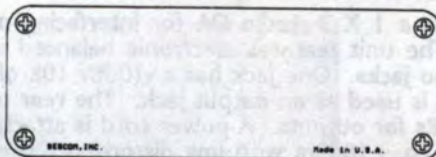
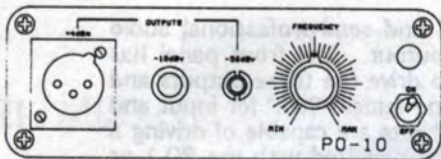

The PO-11 is a stereo phono pre-amp to stereo line out and a summed mono output. The unit features RCA jacks for input and output which are mounted on the rear panel, with attached power cord. The line output level is -10dBv at 10K ohms. It also features low distortion and full frequency response. The unit can be powered with the PO-1 or PO-2 power supplies.

MODEL: PO-12
SOURCE SELECTOR

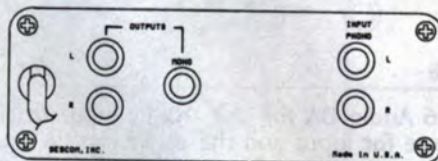
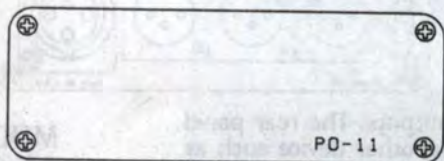

The PO-12 is a stereo assembly with six input to two stereo source selector switch assembly and interlocking push button switches. The input and output connectors are RCA type jacks. The unit requires no power.

MODEL: PO-13
OUTPUT SELECTOR

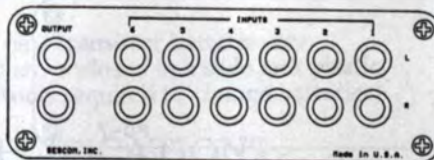
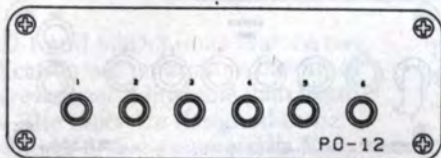

The PO-13 is a stereo input to six stereo output selector assembly. The push selector assembly has non-interlocking switches with two buffer amplifiers to provide low impedance drivers. The rear panel has 14 RCA jacks and a power cable attached. The unit features low distortion and full frequency response. The unit can be powered with the PO-1 or PO-2 power supplies.

MODEL: PO-14
STEREO TONE CONTROL

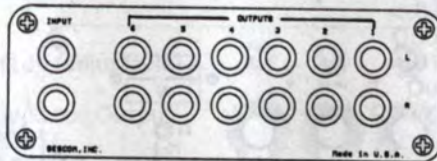
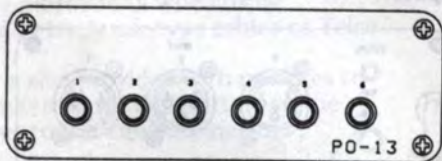

The PO-14 is a stereo tone control assembly with built-in balance control. The unit features electronically ganged bass and treble controls for contouring your line level signals; it also has a balance circuit. The front has three controls; Bass, Treble, & Balance. The rear panel has four RCA jacks for input and output connections and a power cable attached. The unit features low distortion and full frequency response. The unit can be powered with the PO-1 or PO-2 power supplies.

MODEL: PO-15
STEREO SHELVING FILTER

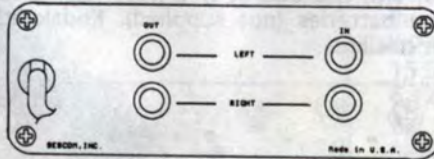
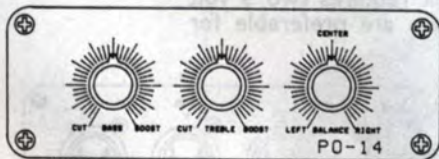

The PO-15 is a stereo shelving filter equalizer for both high and low frequencies. Front panel controls include boost and cut dual gang controls with two position slide switch to change frequency points. Also included is a bypass switch. The rear panel has four RCA jacks for input and output connections and a power cable attached. The unit can be powered with the PO-1 or PO-2 power supplies.

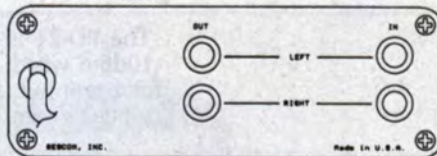
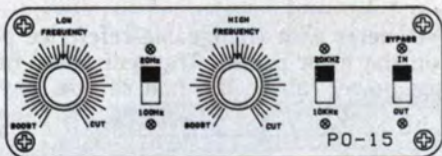

The PO-16 is a mono parametric equalizer with adjustable frequency control, boost & cut controls, three band selector switch, and front panel bypass switch. The rear panel has two RCA jacks for input and output connections and an attached power cable. The unit features low distortion and full frequency response. The unit can be powered with the PO-1 or PO-2 power supplies.

**MODEL: PO-16
MONO PARAMETRIC
EQUALIZER**

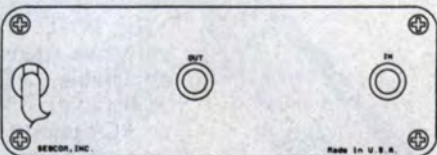
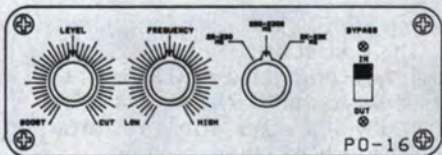

The PO-17 is an interface box for converting outputs of amplifiers to line or mic levels. The unit features input connections 1/4" & 3/16" phone jacks, 1/8" mini phone jack and RCA phono jack output connections. There is a transformer-balanced male "XLR" for mic and line.

**MODEL: PO-17
INTERFACE BOX**

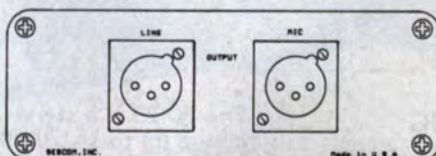
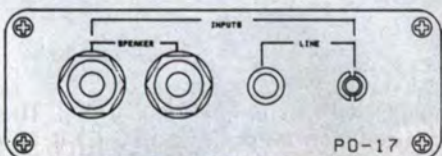

The PO-18 is a line input box to be used from balanced lines to unbalanced output. It has a transformer-isolated assembly. XLR female input connector and 1/4" unbalanced output and RCA jack at semi-pro output level unbalanced.

**MODEL: PO-18
MONO LINE
BALANCE BOX**

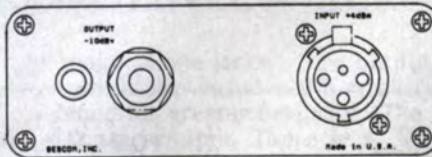
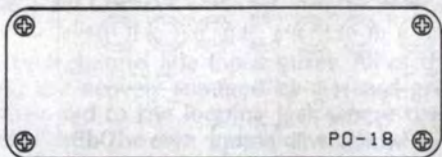

The PO-19 is an output transformer box to balance 600 ohm lines. It features two input jacks, a 1/4" phone jack and a female XLR, and one output male XLR.

**MODEL: PO-19
MONO OUTPUT
BALANCER**

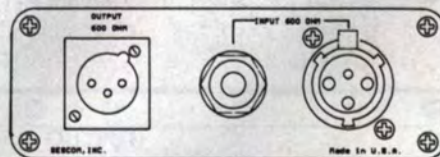
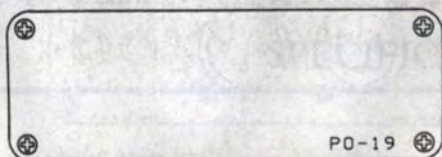

The PO-20 is an input box for microphones that has a balancing transformer to isolate mic circuits. It has a female XLR connector for the input and a male XLR for the output.

**MODEL: PO-20
MONO MIC ISOLATION BOX**

MODEL: PO-21
DUAL VU

The PO-21 is a dual mini VU meter with changeable reference points of +4dBm or -10dBm which is mounted on the front panel. The rear panel has two female XLRs for the input and an attached power cable. The unit can be powered with the PO-1 or PO-2 power supplies.

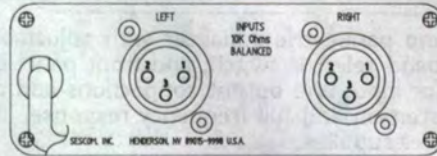
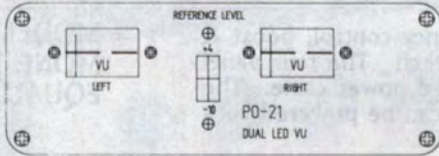

MODEL: PO-22
SEMI-PRO MIC
LINE DRIVER

The PO-22 is a mic-line driver with a low impedance transformer-balanced input with two-stage amplification. The first stage is a fixed gain, and the second stage is adjustable. The front panel has one female XLR and the gain is screwdriver adjustable. The rear panel has two output jacks, one is a 1/4" phone and the other an RCA phono, which are at -10dBv 10K ohms. It has an attached power cable. The unit can be powered with the PO-1 or PO-2 power supplies.

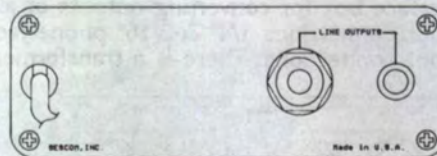
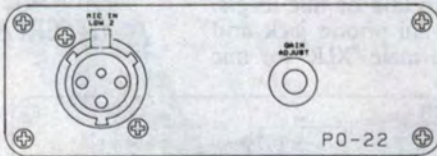

MODEL: PO-23
STEREO SUMMING
AMPLIFIER

The PO-23 is a stereo summing amplifier with six inputs per channel. The PO-23 is designed to sum up to six -10dBv signals into a common output. The PO-23 is an active unit and has RCA jacks for input and output connections. A power cord is attached. The unit can be powered with the PO-1 or PO-2 power supplies.

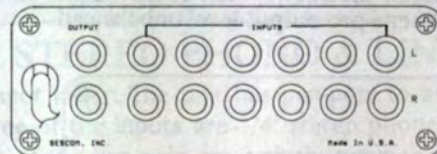
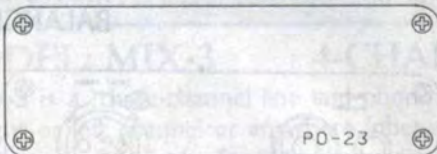

MODEL: PO-24
STEREO LINE DRIVER

The PO-24 is a stereo line driver which will accept two -10dBv 10K ohm signals and convert them to +4dBm 600 ohm electronically balanced outputs. The PO-24 is used for converting semi-pro equipment to professional standards. A power cord is attached. Input connections are RCA jacks and outputs are male XLRs. The unit can be powered with the PO-1 or PO-2 power supplies.

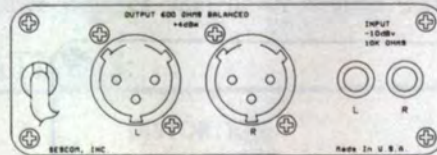

MODEL: PO-25
1 X 3 MIC-SPLITTER

The PO-25 is a low impedance transformer-balanced 1 x 3 "Mic-Splitter" box for splitting microphones. The unit has one direct out and two transformer-isolated splits. All connectors are XLR type.

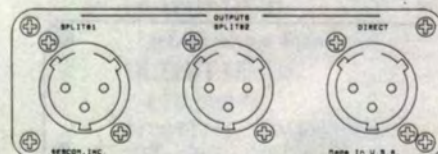
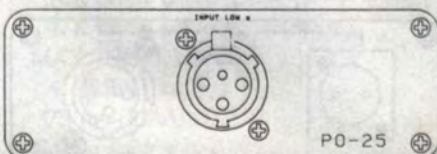

The PO-26 is a deluxe passive direct box which provides a convenient means to interface the output of a musical instrument or keyboard into a low impedance microphone input of a mixing console. A switch on the unit provides the ability to receive a high or low level signal. Another switch will filter the high frequencies out (10KHz), when the other switch is in the high level mode. There is also a ground/lift switch on the output circuit.

MODEL: PO-26
PASSIVE DIRECT BOX

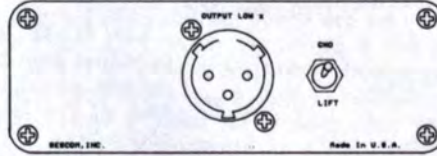
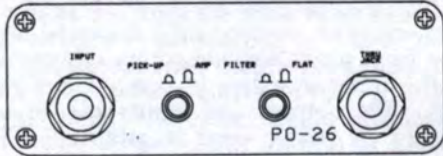

The PO-27 is an active direct box which is designed for use with musical instruments, such as keyboards and electronic type musical instruments. The input is high impedance bridging and the output is a transformer-balanced low impedance at line level. The unit is powered by an internal 9 volt battery (not supplied).

MODEL: PO-27
ACTIVE DIRECT BOX

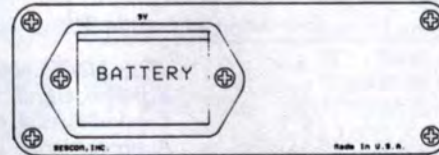
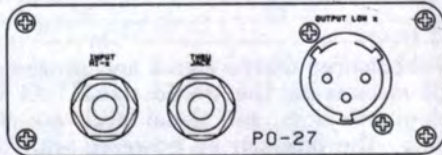

The PO-28 is designed to provide up to four isolated transformer outputs from one input. The input and output connections are XLR type and there are isolation resistors for short protection. The PO-28 has a maximum output level of +18dBm and is designed to work with nominal +4dBm signal levels.

MODEL: PO-28
LINE LEVEL SPLITTER

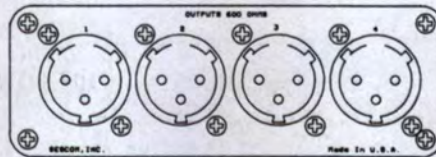
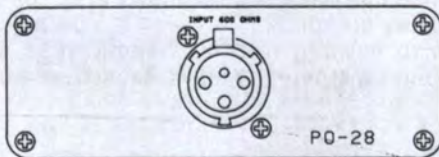

The PO-29 is a portable box designed to listen to either microphone or line level signals via front panel selectability. The unit contains a single 9 volt battery (not supplied) and will drive a single pair of headphones. Mounted on the front panel is a volume control with an integral on/off switch, and two output jacks which are wired in parallel. These are 1/4" phone & mini phone jacks.

MODEL: PO-29
HEADPHONE LISTEN BOX

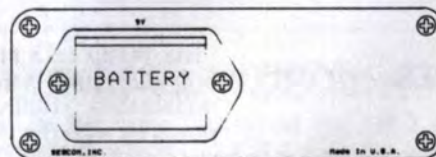
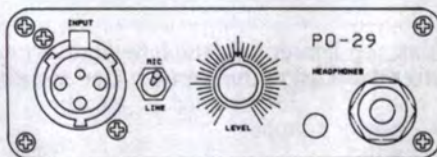

The PO-30 is a balanced "O" pad assembly. The PO-30 is a seven-switch assembly that can give attenuation between 0 and 65dB in one dB steps. The unit is balanced, with XLR input and output connections. It is a passive device with push-button switches.

MODEL: PO-30
PAD BOX 0-65dB

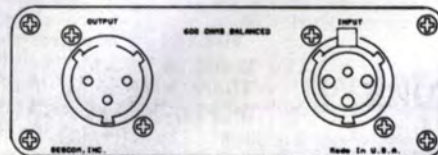
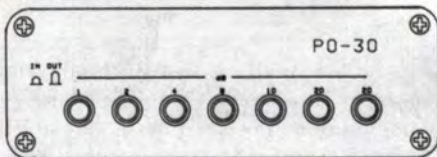

The PO-31 a two-station remote headphone jack box with level controls. There are front panel jacks for 1/4" and 3.5mm; also included are two level controls for each set of jacks. The rear panel has input jacks and thru jacks for daisy-chaining more boxes.

MODEL: PO-31
REMOTE HEADPHONE BOX

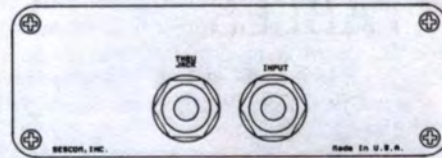
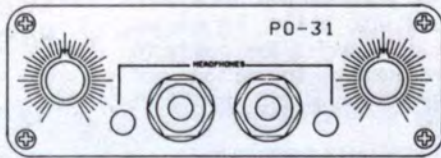

MODEL: PO-32
60dB PRECISION GAIN BOX

The PO-32 is a single-channel electronically balanced input and output precision gain box. The front panel has two rotary selector switches, one for decade switching and the other switches in one dB increments. The total gain of the box is 0dB. The outputs and inputs can be unbalanced. The connectors are XLR type. A power cord is attached. The unit can be powered with the PO-1 or PO-2 power supplies.

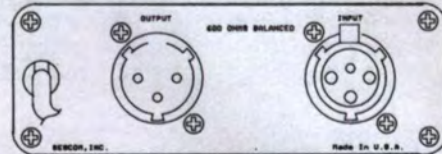
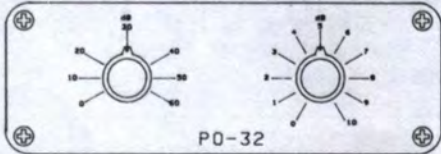

MODEL: PO-33
STEREO COMBINER

The PO-33 accepts an unbalanced stereo signal and actively combines it into a mono signal while still maintaining the stereo signal. All input and output connections are via RCA phone jacks, and signal levels are -10dBv 10K ohms. A power cord is attached. The unit can be powered with the PO-1 or PO-2 power supplies.

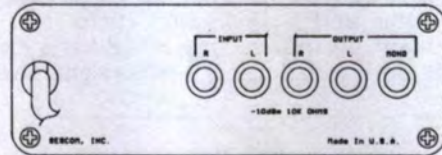
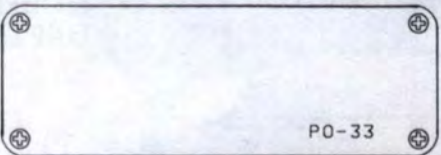

MODEL: PO-34
STEREO AUTOMATIC
LEVEL CONTROLL

The PO-34 is a stereo automatic level control that will accept unbalanced signals from a level range of -40dBv to +12dBv and give a constant level of -10dBv at 10K ohms. A power cord is attached. The unit can be powered with the PO-1 or PO-2 power supplies.

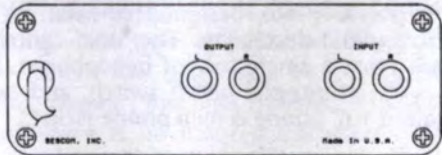
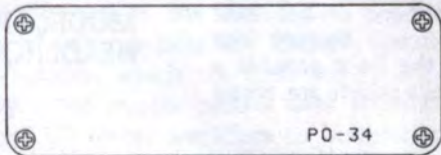

MODEL: PO-35
STEREO FAST ATTACK
LIMITER

The PO-35 is a stereo fast attack limiter designed to limit up to +20dBm. The output will be 0dBm no matter how high the input. The inputs and outputs are unbalanced, -10dBv at 10K ohms. A power cord is attached. The unit can be powered with the PO-1 or PO-2 power supplies.

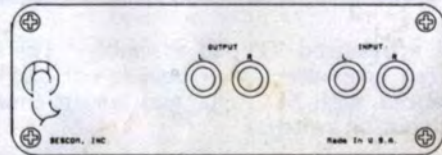
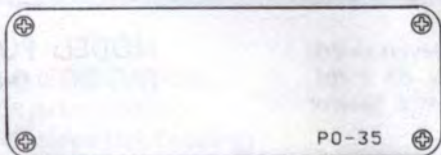

MODEL: PO-36
STEREO NOISE GATE & VCA

The PO-36 is a stereo noise gate and VCA for signal processing problems. Designed to work at -10dBv line level signals in recording and performing musician situations. There is an input gain control and an override switch. A power cord is attached. The unit can be powered with the PO-1 or PO-2 power supplies.

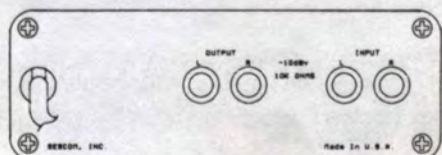

The PO-37 is a pink noise generator for use in sound system equalizing. The unit is self contained with two nine volt batteries (not supplied). The output is line level +4dBm unbalanced.

MODEL: PO-37
PINK NOISE GENERATOR

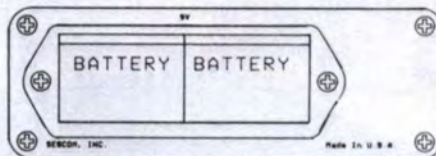
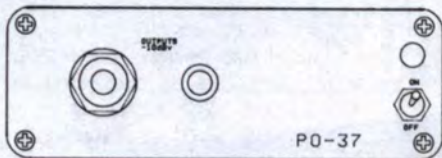

The PO-38 is an XLR turn-a-round box for field use where suddenly the wrong sex of connector appears or there is a need for a "Y" connector. There are two females and two males all wired in parallel.

MODEL: PO-38
XLR "TURN-A-ROUND" BOX

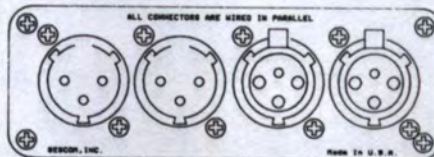
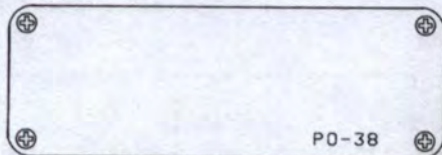

The PO-39 is a high impedance turn-a-round box with two 1/4" stereo jacks, two 3.5mm mono jacks and two RCA phono jacks. All jacks are wired in parallel. A great device for your field kit that will eliminate those annoying misconnections.

MODEL: PO-39
UNBALANCED
"TURN-A-ROUND" BOX

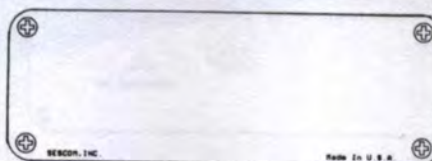
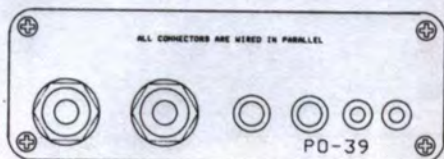

The PO-40 is a mono five-band graphic equalizer for use in sound systems and recording systems. The unit is designed to operate at line level signals. The input and output connections are RCA jacks, the signal level is -10dBv. The unit has five frequencies (60,240,1000,3000,&10,000Hz) with boost/cut of 12dB. There is also a bypass switch and there is a power cord attached. The unit can be powered with the PO-1 or PO-2 power supplies.

MODEL: PO-40
MONO FIVE BAND
GRAPHIC EQUALIZER

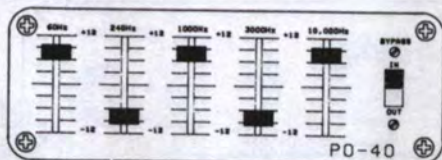

The PO-41 is an AC-powered semi-pro mic-line driver. The unit features a low-impedance transformer-balanced input and two-stage amplification. The second stage is screwdriver-adjustable from the front panel. The front panel has one female XLR, gain adjust, power LED and on/off switch. The rear panel has two output jacks, one 1/4" phone and the other RCA phone which are at -10dBv 10K Ohms. There is an internal AC power supply with fuse and AC power cord.

MODEL: PO-41
AC POWERED SEMI-
PRO MIC-LINE DRIVER

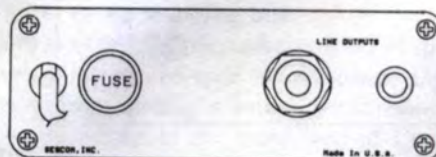
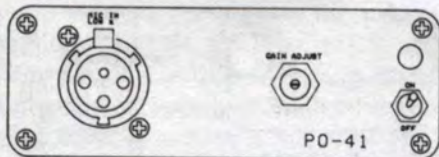

The PO-42 is an AC power supply to be used with phantom powered microphones. The unit has two channels and will supply regulated 48 volts to the microphones. It also features isolation transformers which are double shielded to eliminate hum. The input connectors are female XLRs and the outputs are male XLRs. There is a fuse and an AC power cord attached.

MODEL: PO-42
PHANTOM AC
POWER SUPPLY

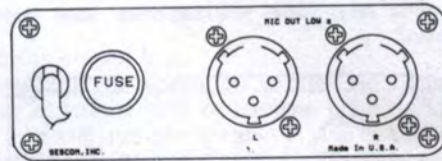
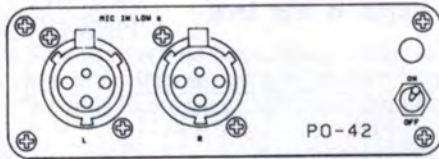

**MODEL: PO-43
RACK MOUNTING
ACCESSORY**

The PO-43 is a rack mounting accessory designed to rack mount up to three PORTABLES in one rack space. Supplied with the unit are two blank panels to cover open spaces in the rack, in case all are not needed, and all necessary hardware.

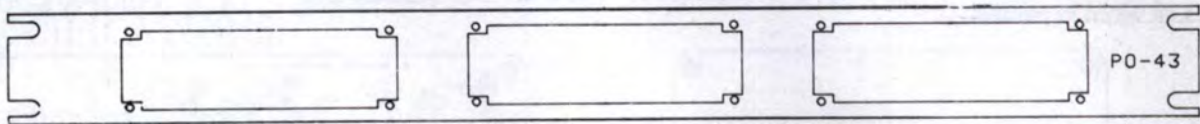

**MODEL: PO-44
TRANSFORMER BOX**

The PO-44 is the companion product to the PO-33 stereo-to-mono converter. It has transformers for input and output functions; two 15K ohm bridging input and three 600 ohm output transformers. Input connections are made on RCA phono jacks and outputs are on screw terminals.



**MODEL: PO-45
STEREO HEADPHONE
LISTEN BOX**

The PO-45 is a stereo headphone box for mic or line function. The input is transformer-balanced with XLR connectors. On the front panel there is a volume control and two switches, one for on-off and the other mic-line function. The unit uses a nine volt battery in a slide-lock box for easy replacement.

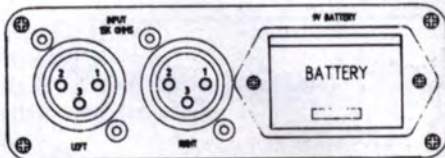

**MODEL: PO-46
MONO ECHO
EFFECTS BOX**

The PO-46 is a mono echo effects box designed to work in a system to give a signal delay over 10 ms long. The amount of echo is adjustable with a front panel control. The inputs and outputs are RCA phono jacks. The unit is designed to work at -10dBv levels. The unit requires a PO-1 power supply.

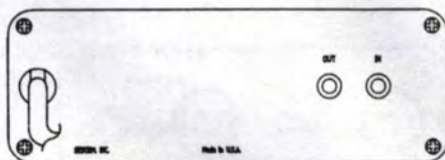

**MODEL: PO-47
MONO REVERBERATION**

The PO-47 is a mono reverberation-effect generation box. The delay is about 100 ms with a cutoff frequency about 3KHz and distortion below 0.5%. The inputs and outputs are RCA phono jacks. The unit is designed to work at -10dBv levels and requires a PO-1 power supply.



The PO-48 is a tone burst generator for testing peak distortion in loudspeakers. Both the cycles-on and cycles-off function are front panel adjustable. A tone generator is required to make the system work. The input and output connections are RCA phono jacks. The unit is designed to work at -10dBv levels and requires a PO-1 power supply.

MODEL: PO-48
TONE BURST GENERATOR

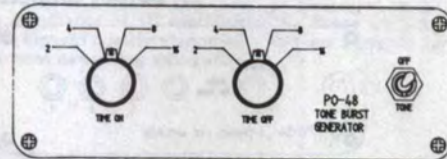

The PO-49 is a portable sound level meter with a high quality electret condenser microphone. The unit has a range of 40 to 120dB. It has a switchable "A" weighted network or can be set in the flat position. Another switch selects a slow or fast response time. The unit requires a 9 volt battery which is mounted in a slide-lock case.

MODEL: PO-49
SOUND LEVEL METER

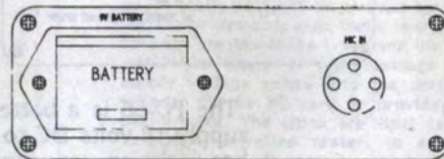
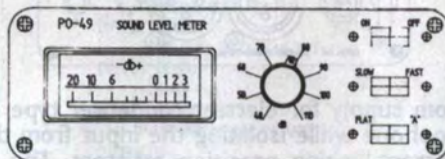

The PO-50 is a video DA with one input and three outputs. The input is bridging and the level is adjustable; the outputs are 75 ohms. The connectors are BNC type and are mounted on the rear panel. The unit requires the PO-1 power supply.

MODEL: PO-50
VIDEO DA

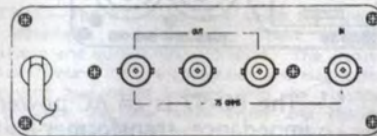

The PO-51 is a three-way active crossover which is designed to drive three power amplifiers. The crossover frequencies are changeable by inserting different value resistors. Data is supplied with each unit. The unit has bass, mid-band and high frequency outputs at -10dBv levels. The unit requires a PO-1 power supply.

MODEL: PO-51
3-WAY ACTIVE CROSSOVER

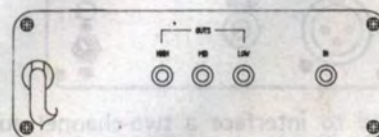
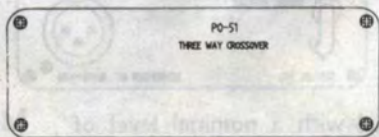

The PO-52 is a frequency shifter for eliminating feedback in sound systems. The unit shifts the audio frequencies by 90 degrees. The unit should be used for voices only. The input and output are RCA phono jacks and the levels are -10dBv. The unit requires a PO-1 power supply.

MODEL: PO-52
FREQUENCY SHIFTER

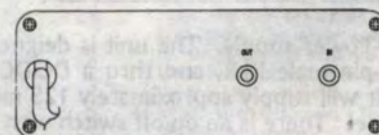
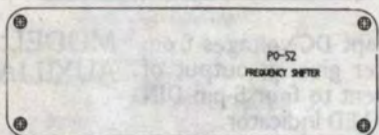

**MODEL: PO-53
MIC-COMBINER**

The PO-53 is a 2 x 1 "Mic-Combiner" for combining low impedance microphones. The inputs are isolated to prevent field problems. The inputs and outputs are XLR connections.



**MODEL: PO-54
4-CHANNEL
LINE AMPLIFIER**

The PO-54 is a four-channel line amplifier with individual controls. The unit operates at -10dBv semi-pro level both inputs and outputs. PO-54 is designed to mix line level signal into a common output. The input and output connectors are RCA type.

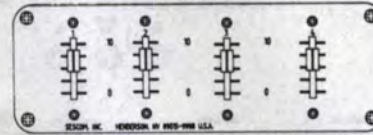
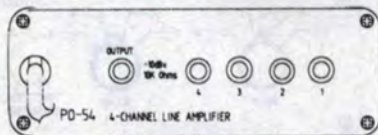

**MODEL: PO-55
AC POWERED STEREO
LINE DRIVER**

The PO-55 is a stereo line driver which will accept two -10dBv 10K ohm signals and convert them to +4dBm 600 ohm electronic balanced outputs. The inputs are terminated in RCA jacks and the outputs are terminated in male XLRs. There is a fuse and AC power cord attached.

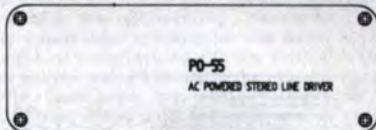

**MODEL: PO-56
PHANTOM
BATTERY SUPPLY FOR
MICROPHONES**

The PO-56 is a battery phantom supply for electret condenser type microphones. It will supply 18 volts DC to the microphone while isolating the input from the voltage. The unit has isolation capacitors and current-limiting precision resistors. The unit will power two microphones and requires two nine volt transistor batteries (alkaline recommended/not supplied).

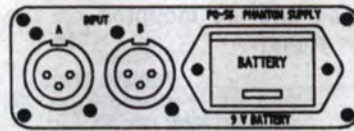
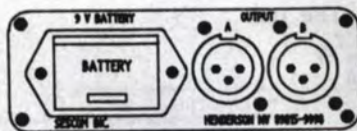

**MODEL: PO-57
AC POWERED MIC
LINE DRIVER**

The PO-57 is an AC powered professional mic-line driver. The unit features a low impedance transformer-balanced input and output with two-stage amplification. The second stage is screwdriver-adjustable from the front panel. The front panel has one female XLR, gain adjust, power LED and on/off switch. The rear panel has one male XLR which is at +4 dBm 600 ohms. There is an internal AC power supply and an automatic resettable fuse with attached AC power cord.

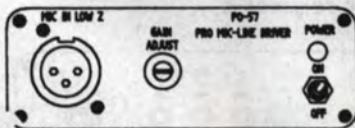

The PO-58 is designed to interface a two-channel audio signal with a nominal level of -10dBv, unbalanced, to speakers or headphones with 2 watts of undistorted audio output at 8 ohms or greater. The unit has a self-contained AC power supply.

**MODEL: PO-58
2 WATT POWER
AMPLIFIER**

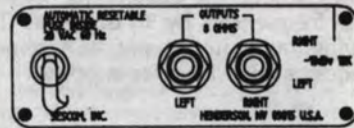

The PO-59 is an Auxiliary-Power supply. The unit is designed to accept DC voltages from 12 to 24 volts via a four-pin male XLR, and thru a DC-DC converter give an output of plus and minus 12 VDC. It will supply approximately 125 ma of current to four 5-pin DIN connectors on the rear panel. There is an on/off switch with a power LED indicator.

**MODEL: PO-59
AUXILIARY POWER SUPPLY**

If You Didn't Get This From My Site,
Then It Was Stolen From...

SESCOM, INC.
2100 Ward Drive
Henderson, NV 89015-9998 U.S.A.

ADDRESS CORRECTION REQUESTED

TO:

BULK RATE
U.S. POSTAGE
PAID
PERMIT NO. 882
LAS VEGAS, NV.