

RAMKO RESEARCH

PROFESSIONAL AUDIO PRODUCTS

● OPERATION INSTRUCTIONS ●

DC 8M

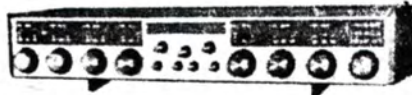

DC-8M



RAMKO RESEARCH, Inc.
11355 Folsom Blvd.
RANCHO CORDOVA, CALIF. 95670

6000
1/2 2500

RAMKO RESEARCH, INC.

Professional Audio Products

(916) 535-3600

INTRODUCTION

Congratulations! You have just taken a major step toward improving the quality of your sound and the reliability of your operation. As you will note your new RAMKO console embodies features that until now have been available only on units selling from 5 to 10 times more. In addition you will find features that are available only in your unit. From our exclusive TOUCH PAD switching to the better than a "VU" meter solid state light emitting meter.

Although your console has been 100% tested prior to shipment and packaged in a highly shock resistant manner we find that there are some freight lines that seem to take delight in testing our methods. This is usually through the drop method. Therefore BEFORE turning the unit on PLEASE take the time to remove the top cover and check to see that no internal damage has occurred and that all plug in cards are properly seated.

In addition if you'll take the time to read the following circuit descriptions and familiarize yourself with the relatively simple but new concepts you'll be time and money ahead.

Thank you for the opportunity to serve you. We will look forward to being of further assistance in the future

Very sincerely



R. G. Kohfeld
President

SPECIFICATIONS:

Inputs: 18 inputs into 8 mixers (DC 8). 12 inputs into 5 mixers (DC 5 and SC 5). All inputs (except last channel) gain selectable from low thru high. LOW LEVEL—150/250 ohms balanced; shipped -55 dbm nominal, -25 dbm max. HIGH LEVEL—Balanced bridging (100K each side to ground). As shipped -10 dbm nominal, +10 dbm max. Input impedance may be changed to any lower impedance by placing appropriate resistor across input terminals.

Outputs: PROGRAM—600 ohm differential balanced. + 8 dbm nominal, +20dbm max. AUDITION—same as program. MONITOR—5 watts RMS per channel into 8 ohms. Cue—0.5 watts to internal speaker HEADPHONES—8 ohms thru high impedance. Rear panel jack.

Freq Response: PROGRAM & AUDITION—+0, -2 db 10 Hz to 20 KHz referenced to 1 KHz at +8 dbm out. MONITOR—+0, -2 db 30 Hz to 15 KHz referenced to 1 KHz @ 1 watt out.

Distortion: PROGRAM, AUDITION, COMBINED STEREO & MONITOR DRIVER—0.3% or less. MONITOR—1% THD or less at rated load & output.

Signal To Noise: PROGRAM, AUDITION, COMBINED STEREO—Noise 65 db (unweighted) below +8 dbm out, referenced to -50 dbm in.

Muting: Patch panel concept allows selection of any of 28 combinations (DC 5) & 8 combinations on the SC 5. Cue mute follows monitor mute. Headphone cue unmuted.

Power: 10 to 30 watts 117 VAC, 50/60 Hz, 230 VAC, 50/60 Hz optional

Size: DC 8's—8" H X 36 3/8" W X 14 1/2" D. SC 5M & DC 5's — 8" H X 27 3/8" W X 14 1/2" D. SC 5R — 7" H X 19" W X 14 1/2" D.

Options: 230 VAC, 50/60 Hz. LC 2 & LC 4 accessory remote control, IX 34 input expander. EQ 4 four channel equalizer and slide attenuators. Contact factory for more information.

OPERATING INSTRUCTIONS

DC 8M & DC-8MS AUDIO CONSOLE

1. As supplied channels #1 and #2 are set up for mic levels -55dbm nominal. Channels #3, #4, and #5, #6, #7, and #8 are all high level -10dbm nominal.
2. All inputs are balanced. Any input may be used unbalanced by simply shorting the -terminal of that input to ground.
3. As supplied channels #1 and #2 are muted. Muting is selected via the yellow jumpers and socket located next to that input channel card. Muting may be removed by removing the appropriate jumper. Reading from right to left facing the rear of the console the muting jumpers are input #2, input #1, Program Audition.
4. Input select and Audition/Program/Off select are located directly above each channel fader. Channel #8 has the additional feature of simulcue. The rotary switch is the input select while the red pushbuttons are for simultaneously monitoring thru the cue amp and phones, any of the other 3 inputs on that channel.
5. Short all unused inputs.

HOOK UP INSTRUCTIONS

AUDIO CONSOLE MODEL DC-8M

Note: Reading from right to left - facing rear of console

1-	Ch 1 in 1 left	50	Ground
2+		51+	Ch 6 in 2 left
5	Ground	52-	
6+	Ch 1 in 2 left	55-	Ch 7 in 1 left
7-		56+	
10-	Ch 2 in 1 left	59	Ground
11+		60+	Ch 7 in 2 left
14	Ground	61-	
15+	Ch 2 in 2 left	66+	Ch 8 in 1 left
16-		67-	
19-	Ch 3 in 1 left	70+	Ch 8 in 2 left
20+		71-	
23	Ground	72	Ground
24+	Ch 3 in 2 left	75+	Ch 8 in 3 left
25-		76-	
28-	Ch 4 in 1 left	79+	Ch 8 in 4 left
29+		80-	
32	Ground	81	Combined stereo output
33+	Ch 4 in 2 left	82	L out
34-		83	R out Monitor Driver
37-	Ch 5 in 1 left	84	Ground
38+		85	IN (Air in-single ended input)
41	Ground	86	IN 85 & 86 in will Mix
42+	Ch 5 in 2 left	87+	L prog out
43-		88-	
46-	Ch 6 in 1 left	91	Ground
47+		92+	L Aud out
		93-	



OPERATOR CONTROL

1. Channel Input Select group. Illuminated TOUCH PAD input selectors indicate at all times which input is ON (illuminated).
2. Audition, Program, Off select. Performs proper routing of the above selected input.
3. Talk back switch. User option. Comes mounted on all consoles but not wired. See Calibration & Adjustments section.
4. Command signal bearing escutcheon plate. Has 17 VAC, very low current, signal imposed on it for positive TOUCH PAD switching.
5. Channel mixer control. Like the TOUCH PAD switches above, it is a DC control & remotely controls the Electronic Attenuator on the plug in cards.
6. Channel #5 or #8 mixer input select switch. Selects 1 of 4 different inputs for this channel
7. SIMUL-Q. Allows operator to cue up any of the above 4 inputs even though you are simultaneously on the air on this channel.
8. Solid state "VU" meter. Instantaneous reaction on the way up & VU ballistics on the way down. Allows you to accurately (for a change) monitor what is going thru without missing anything. Factory calibrated for +8 dbm at 0 "VU". May be easily recalibrated for other levels in the field.

FM stereo. LEFT & RIGHT outputs are displayed. For mono, the Program is on the Left & the Audition is on the Right.
9. Master Level Control. On stereo units this control will simultaneously adjust your LEFT Prog. & Aud. output levels. On mono units this control will adjust Prog. out only.
10. Master Level Control. On stereo units this control will simultaneously adjust your RIGHT Prog & Aud. output levels. On mono units this control will adjust Aud out only.
11. Cue Gain Control. The control adjusts the level of the internal cue speaker only.
12. Phones Gain. Adjusts the level of phones only.
13. Phones Input Select. Selects between Air, Cue, Prog, Aud, & monitor. Muting has no effect on this function.

14. Monitor input select. Selects among Air, Prog & Aud.
15. Monitor Level Control. Adjusts level fed to MA 14 or other monitor amplifier.

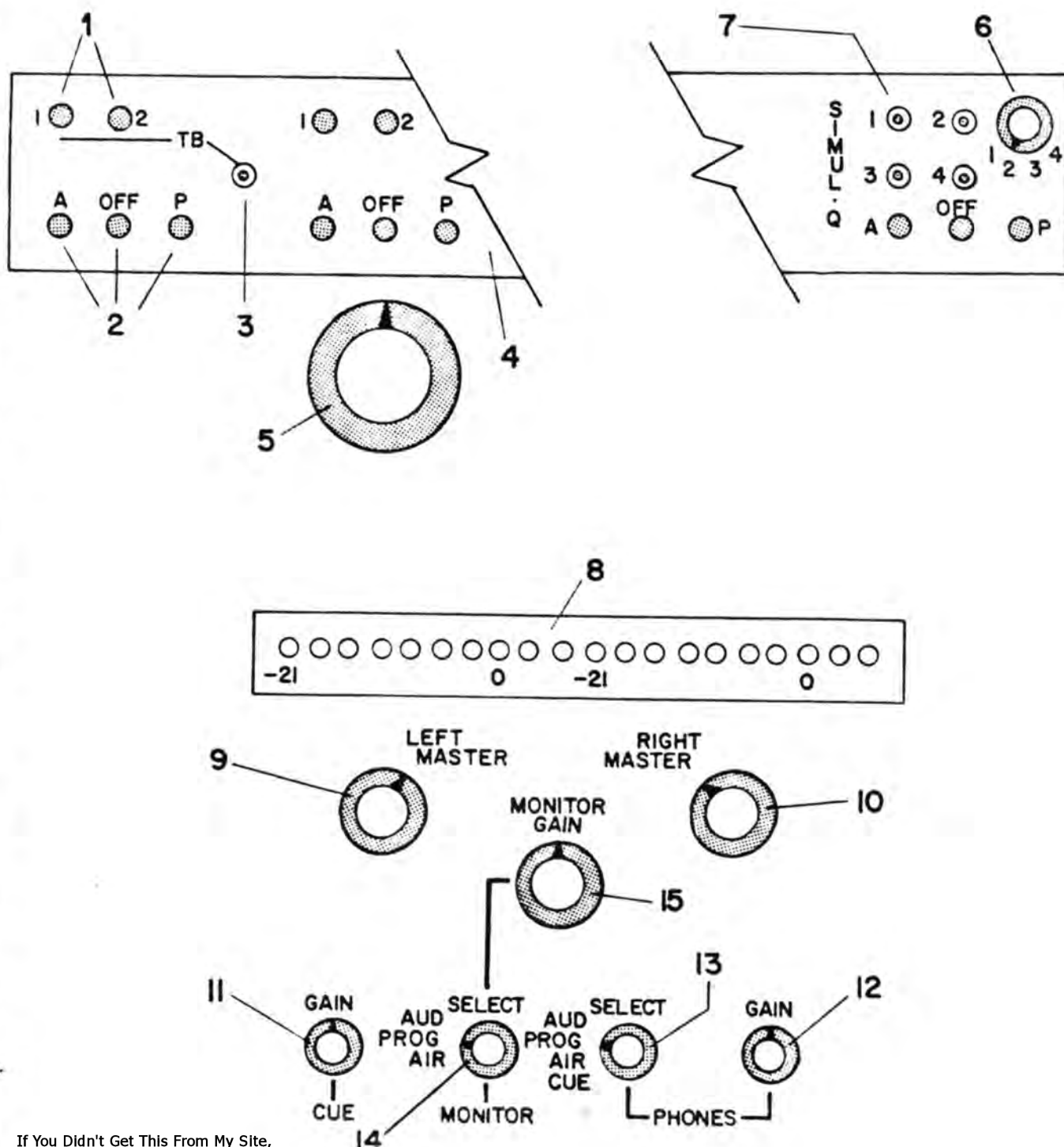

THEORY DISCUSSION

With the exception of the console power supply & cue amplifier all active circuitry (amplifiers & COS/MOS switching) utilizes only four different IC's. The RC 4136 quad op amplifier; the RC 4558 dual op amp; the CA 4016 quad COS/MOS analog switch; the CA 4069 COS/MOS hex inverter. All electronic attenuation is eventually accomplished via the VTL 5C4 2 Led & dual photo detector unit.

Although you are probably familiar with op amp operation it may be best to briefly review their functions before getting into COS/MOS switching & the audio console circuitry.

For illustration purposes a single section will be discussed.

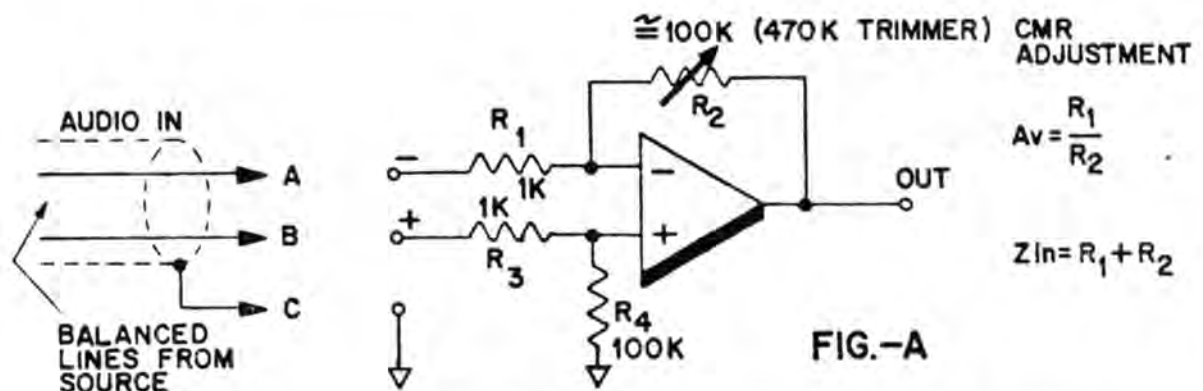

The above circuit is typical of the balanced differential input circuit found in your audio console. The two things you will be concerned with are gain (gain select patch panel) & common mode Rejection (CMR). The latter being a direct function of how well the inputs are balanced. The circuit shown is set up for -55 dbm input level (mic level) & provides the following console amplifiers with enough level for a nominal mixer setting of around 12 o'clock & + 8 dbm out at the PROG and AUD outputs. By referring to the schematic of the electrically switched preamp card you will see that the two resistors (R1 & R3 above) may be changed to accommodate any input level(s) desired. In order to save you time & a lengthy math dissertation a Gain Select Chart & example sheet are included in the back of this manual. Be sure to observe the notes at the bottom of the chart. If changing these resistors upsets the input balance (CMRR) to any great extent the CMR adjust may have to be recalibrated. This will only be necessary in a few isolated cases where high common mode hum is present on your balanced lines. Simply feed a common signal to inputs A & B with reference to ground & adjust the CMR adjust for a null or minimum signal out of the console.

This type of input stage may also be used in the single ended (unbalanced) configuration & would be connected as shown in FIG B. The minus input terminal is grounded & the signal "hot" lead is connected to the + input & the ground connected to ground. No readjustment of the CMR adjust is needed no matter what input resistor values are used.

To change gain the same chart as before is used & again both R1 & R2 are changed.

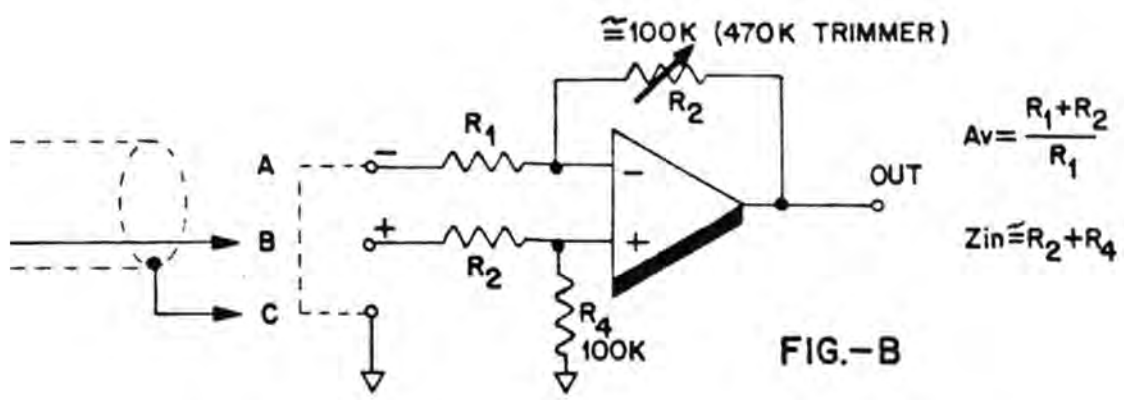

FIG.-B

There are four other types of op amp circuits used in your console (1) A standard non inverting configuration: (2) an inverting configuration: (3) the balanced/differential output stage: (4) and the DC voltage comparator used in the cue circuitry.

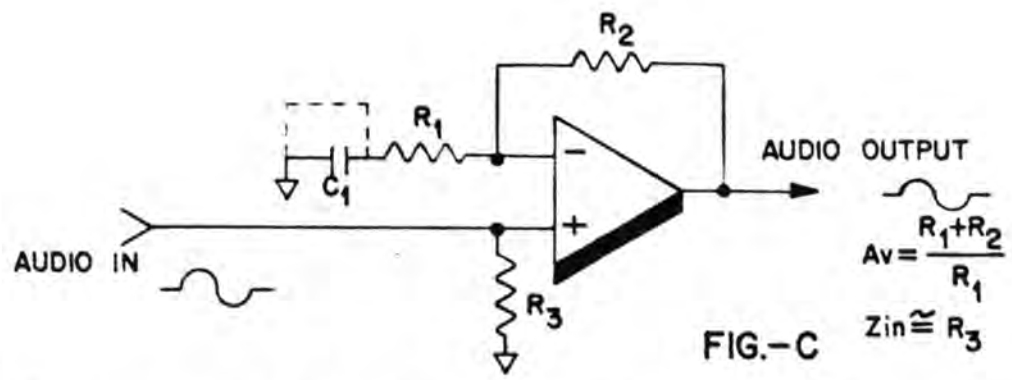

FIG.-C

1. The non inverting type is shown in FIG-C along with some minor math used to compute the gain of this stage. The output of this stage will always be in phase with the input.

R1 may sometimes go directly to ground. This in no way affects the phase or computations above.

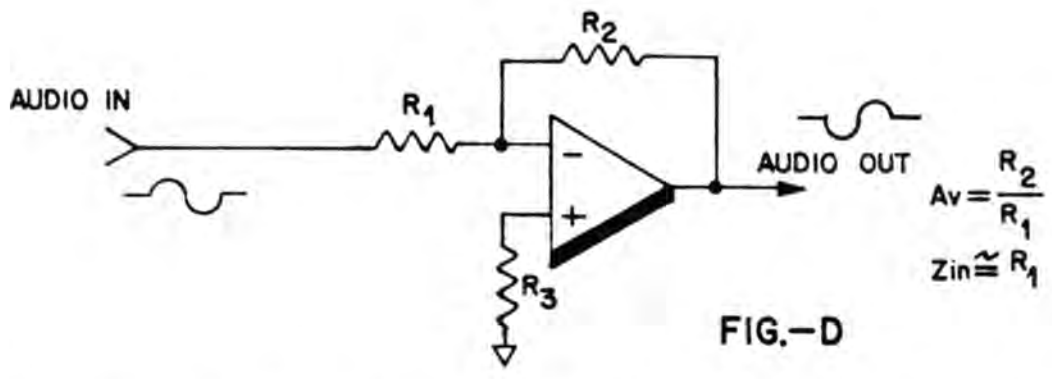

FIG.-D

2. The inverting configuration in FIG-D is just as simple as the non inverting. The output of this stage is 180° out of phase with the input

R3 is for biasing considerations only.

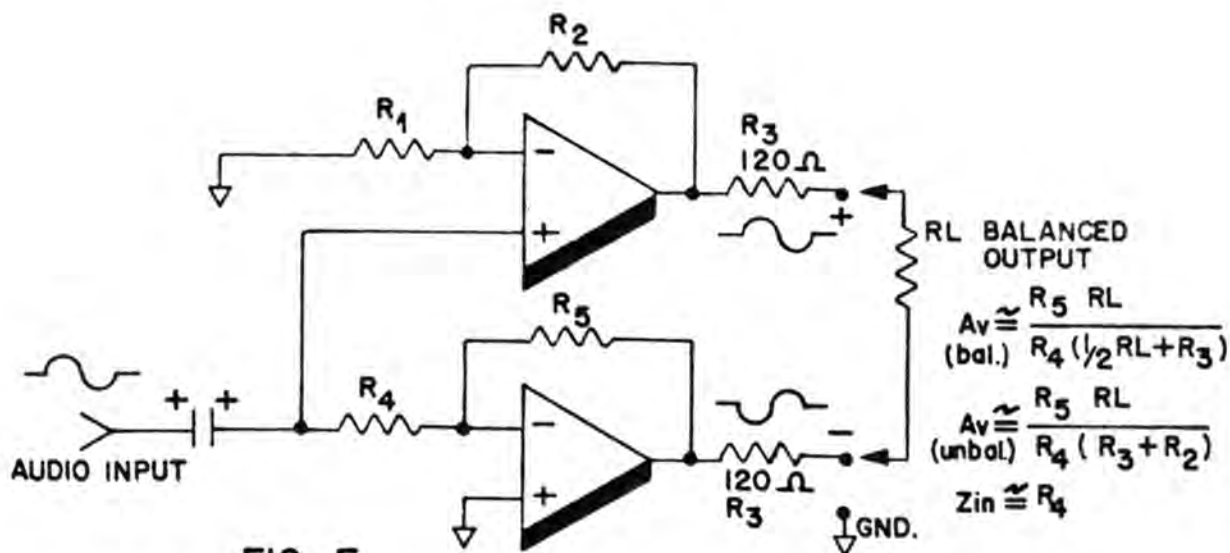

FIG.-E

- 3 • FIG-E depicts the balanced/unbalanced outputs utilized in your console. There are several terms to note about this unique stage. First, unlike transformer outputs, this output circuit's distortion & response will remain unaffected by changes in output loading. In fact, anything from 600 ohm thru infinity may be used without signal degradation. In addition, either side of the balanced out (+ or -) may be used unbalanced to ground simultaneously or individually.

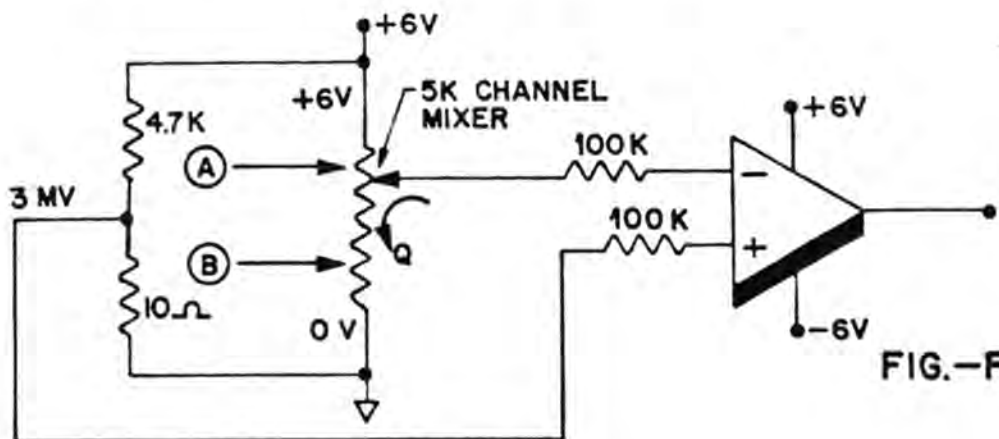

FIG.-F

- 4 • The cue amp switching circuit also utilizes the op amp but in this case as a DC comparator (level sensing switch).

This circuit is used in the inverting mode with no feedback. Since we are operating open loop, the gain of the op amp is approx. 120 db ($AV=1,000,000$). The plus input is fixed at 2.3mV via the voltage divider & the minus is connected to the wiper of the front panel mixer control. Let us assume that your mixer is set around 12 o'clock (mid position) & pretend this is a linear pot instead of the audio taper that it actually is. Thus the -terminal of the op amp will see -3V & the + terminal +.003V. Multiply the difference between these two terminals by the gain of the amp & you have the output voltage. $(3V - .003) (-1,000,000) = -2,997,000$ volts! Well, the sign is right (minus), but the voltage is wrong since the amp can only switch to around ± 6 volts (to supply voltage). We now have approx. -6 volts out, which by the way will eventually turn on the CUE AMP circuitry.

elsewhere. Let's turn the mixer down towards CUE low until the wiper potential is almost the same as the fixed potential (3MV). Let's make it say 5MV & see what happens. $(.005 - .003) (-1.000.000) = -2000V$. Once again the op amp output is minus but can only go to minus 6V. Now let us turn it further towards CUE (grd) to say 1MV. Thus $(.001 - .003) (-1.000.000) = +2000V$! Note that as the wiper crossed 3MV the output switched positive. This time to the plus supply (+6V). That's it! An electronic comparing switch that goes either to +6 or -6V out.

The last 2 types of IC's to be examined are the 4016 quad analog switch & the 4069 hex inverter.

FIG G below depicts the 4016.

FIG.-G

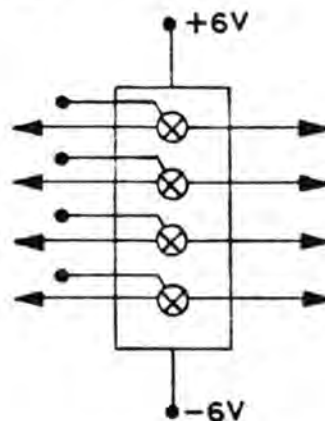

The straight thru arrows indicate direction of signal flow back & forth thru the gate. These gates are bilateral so the signal may flow in either direction. The gate control will always be depicted as coming off of the gate at a 45° angle. The only things to remember about these gates are: (1) the gate will be ON if the gate control has a +6V applied to it & OFF if it is -6V; (2) the gate appears as a few hundred ohms when ON & many megohms when OFF; (3) the 4016's are used to gate DC voltage (for logic) as well as routing audio signals; (4) always use a high impedance meter when taking voltage measurements.

The last IC to be discussed here is the 4069 hex inverter shown in FIG H below.

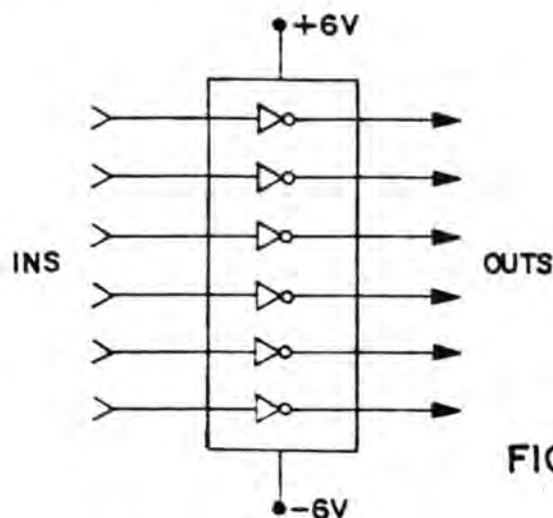

FIG.-H

The hex inverter is exactly as its name implies. Six independent inverting amplifiers. These are not to be confused with inverting op amps as they prefer to see something at their inputs that is either one way or the other. In this case the something will always be +6V or -6V. There are only two things to remember with these IC's. First if a +6V is applied to the input -6V will appear at the output. Secondly use only a high impedance meter for measurements since the sections are capable of supplying only about 1 ma or less out. These IC's are used only in the front panel TOUCH PAD controls.

CIRCUIT DESCRIPTION

Starting at the input section & referring to the Electrically Switched Preamp you will see that the signal goes thru first the gain select input resistors, then 2 stages of gain & finally out of the 4016 COS/MOS switch.

From there the signal goes thru the interconnect jumpers on the mother board to the input of the Electronic Attenuator & Switch card. The signal is fed into the VTL 54C Light Emitting Diode / Photocell combination. The op amp at this point is a voltage to current converter & is used to convert the voltage from the front panel mixers to a current for the LED. It should be noted here that the VTL 54C exhibits a very linear relationship of attenuation to LED current. After passing thru the attenuator the signal is fed to the 4016 AUD/OFF/PROG select gates & then into isolation buffer amplifiers & finally into the active AUD & PROG mixing busses. The above holds true for all Dual Channel consoles but not for the SC series single channel consoles. Instead after the signal goes thru the photocell it goes directly into isolation buffer amps which feed the Prog active mixing buss. All input & off select is done prior to this card on the ESDP input card. In addition the ESDP (SC 5's only) contains the electronic comparators & 4016 cue switch. When the mixer(s) are rotated fully counterclockwise (cue) the comparator(s) change voltage state thus turning on the 4016 gates & therefore routing the unattenuated signal into the active mixing cue buss. The same thing happens in the DC series console except this circuitry is located on the motherboard(s) adjacent to the plug in cards. After the signal is injected into the active mixing buss it goes to the output cards. Audition, Program, Phones, Cue, etc. Although portions of this part of the circuitry are complex enough not to be self explanatory you will readily see that the same type of COS/MOS switching & electronic attenuation is used as has been described previously.

The mute circuitry is straight forward & utilizes the patch panel jumpers to route the selected combination of input select voltages to the mute buss. This in turn is connected to the base of a 2N3565 transistor. When the proper combination of inputs are selected & match that of the programmed patch panel the mute buss tries to go positive. This causes the transistor to conduct which causes the collector voltage to go from +6 to -6 volts. This -6V now switches certain COS/MOS gates OFF thus preventing the signal from reaching the CUE AMP & MONITOR AMP.

The Solid state meter incorporated in your console consists of 6 different functional circuits. (1) The precision full wave rectifier (IC-1A & IC-1B); (2) the display delay network (1 meg & .22uf) which affords fast attack & slow decay; (3) the temperature compensated voltage reference (2N3565 & 5.6V zener); (4) the constant current generator (IC-1D); (5) the transistor switches driver (IC-1C); (6) & the display itself (10 transistors & 10 LEDS).

The first thing to remember is that in the no signal state all display LEDS are shorted out by the parallel transistors. These transistors are

all conducting until a signal comes along & one by one are turned off. When the transistors turn off this short is essentially removed thus allowing the LEDS to light. The second thing to keep in mind is the constant current generator IC-1D. Since the display chain is in the feed back loop of IC-1D & the + & - inputs of the IC are connected across the 5.6V zener, the current thru the LEDS & transistors will always be the same. Thus the display intensity will remain constant regardless of whether only 1 LED is on or all are on. Let's now go back & trace a signal thru. IC-1B & IC-1A comprise the negative going full wave rectifier. This rectifier converts the audio signal into negative pulses which in turn drive IC-1C. This non inverting amp in turn has a negative going output that sequentially turns off the bases of the display transistors. Although this sequence of events has been designed for virtually instantaneous attack time it is immediately apparent that it would be undesirable for it to work the other way. That is, for the display to exhibit an instantaneous release time. If this were the case you find that many transients would come & go so fast that although the meter would track them they would be so fast that the eye would never see them. Therefore the 1 meg & .22uf cap charging network which gives the meter a decay period of about 1/3 of one second. Thus zippity zap on the way up & "VU" ballistics on the way back.

Referring to your TPC schematic you will see that the 4069 hex inverters are used in 2 different ways. At the outputs as bistable flip flops & at the Touch Pad inputs as voltage converters. Note that all of the inputs are connected to the positive supply thru 10 meg resistors. The output of this chip will then be - supply voltage. If you now touch this PAD you are transferring a negative going signal to the input which in turn causes the output of this inverter to go positive. This positive voltage causes the following diode to conduct & cause the following inverter section to go negative at its output. This negative voltage is fed to the adjacent inverters input with its output going plus. The AUD/OFF/PROG section operates in exactly the same manner except that there are steering diodes added to make this section a three state device

In both series consoles the cue amp is a straight forward power op amp configuration. The one thing that should be pointed out here is that on the DC consoles you have a slightly different muting approach than on the SC consoles. Namely the IN4002 diode brought into pin three of IC-1A. What you have here is simply a cue level control override. Thus if mute is in effect, a negative voltage is applied to this diode which in turn causes IC-1A output to go negative thus shutting of the VTL 54C LED. With no mute in effect pin three again takes its command from the front panel cue level control.

EXAMPLE GAIN SELECT SHEET

All Ramko consoles have the distinct advantage of full range gain select on their inputs. Thus unlike other consoles you are not tied to just HIGH/LO select but can adjust the gain of the inputs for any source level (-60dbm thru +10 dbm nominal).

If you will refer to your ESSP (stereo) or ESMP (mono) schematic you will note the audio inputs go thru a small patch panel containing 1K resistors. There are two resistors for each input. One for the minus leg & one for the plus leg of each balanced pair. Whenever an inputs gain is changed both resistors in this input must be changed.

SOURCE LEVEL (Nominal)	INPUT RESISTORS (1)
-60 dbm	510 ohm
-55 dbm	1 K
-50 dbm	1 8 K
-45 dbm	3 3 K
-40 dbm	5 6 K
-35 dbm	10 K
-30 dbm	18 K
-25 dbm	33 K
-20 dbm	56 K
-15 dbm	100 K
-10 dbm	150 K
0 dbm	560 K
+10 dbm	1.5 meg (2)

- (1) All resistors should be 1/2 watt. Resistors used in low level applications should be carbon or metal film low noise types
- (2) Not recommended due to possible hum pickup. Suggest external signal pad down for these levels.

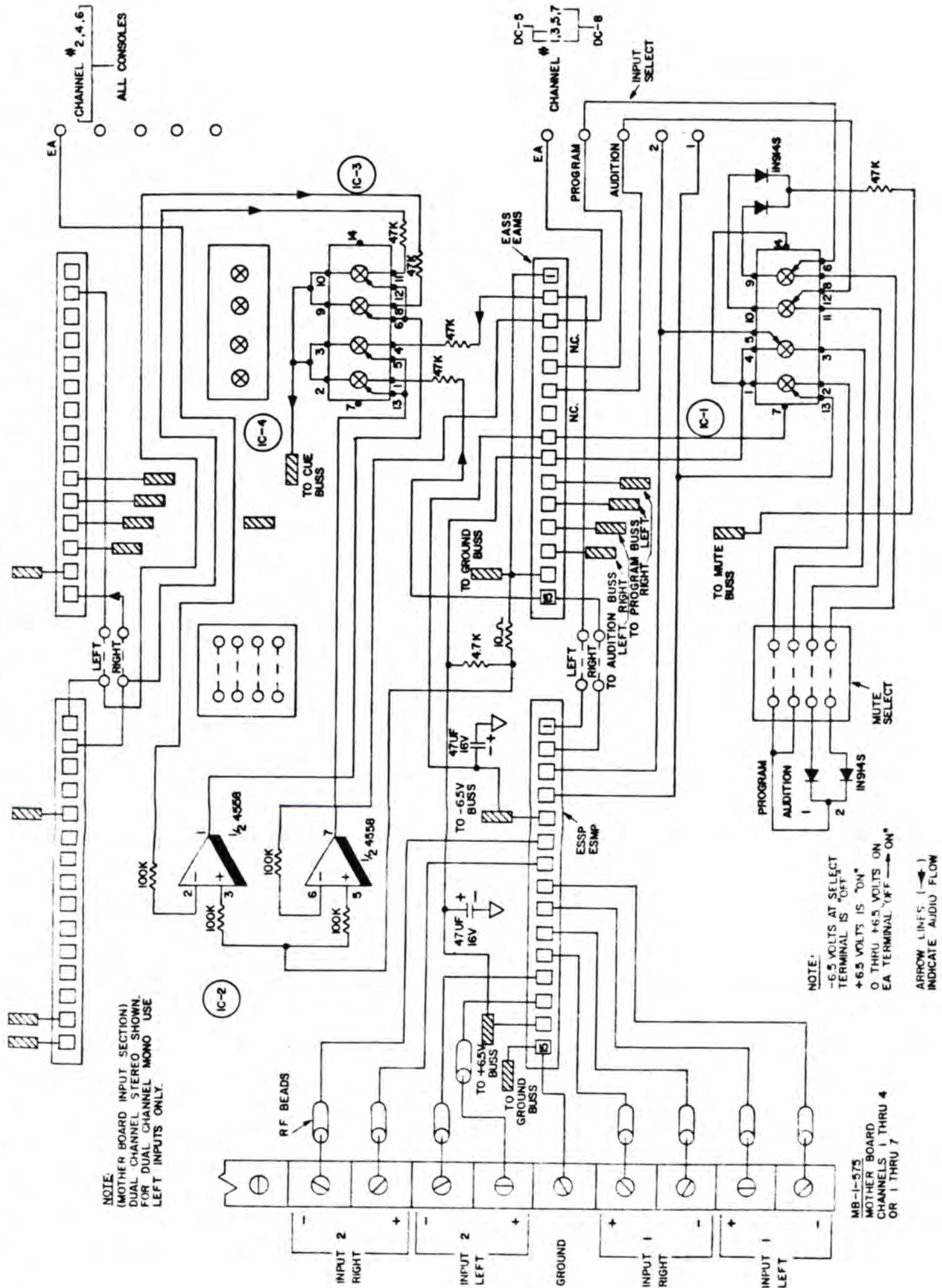

NOTE:
 (MOTHER BOARD INPUT SECTION)
 DUAL CHANNEL STEREO SHOWN.
 FOR DUAL CHANNEL MONO USE
 LEFT INPUTS ONLY.

NOTE:
 -6.5 VOLTS AT SELECT
 TERMINAL IS "OFF"
 +6.5 VOLTS IS "ON"
 0 THRU +6.5 VOLTS ON
 EA TERMINAL "OFF" → "ON"

ARROW LINES (→) INDICATE AUDIO FLOW

MB-1-575
 MOTHER BOARD
 CHANNELS 1 THRU 4
 OR 1 THRU 7

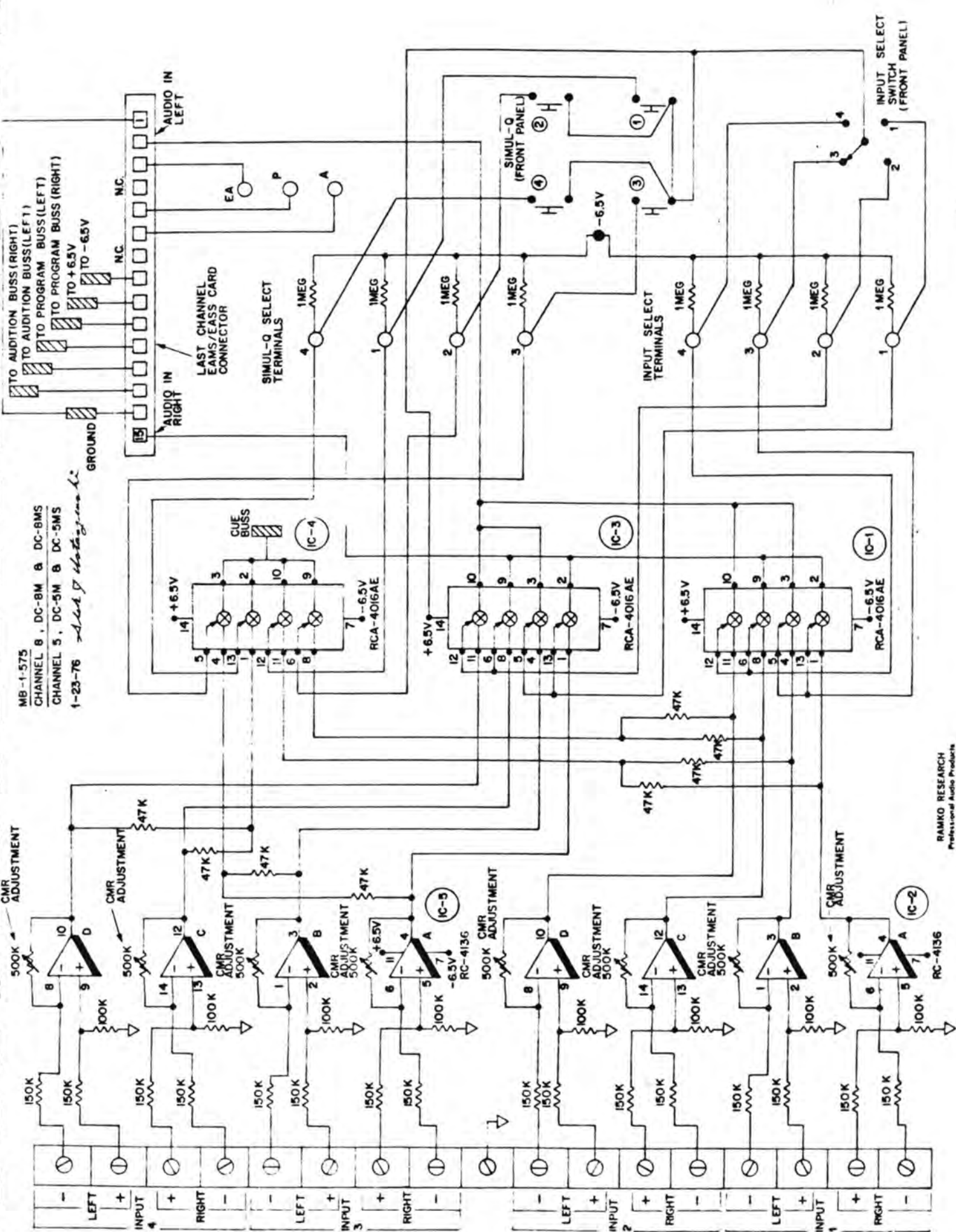

MB-1-575
 CHANNEL 8, DC-BM & DC-BMS
 CHANNEL 5, DC-5M & DC-5MS
 1-23-76 *Handwritten note*

MBOC-1-575
MOTHER BOARD
OUTPUT CARD
10-22-75

NOTE:
-6.5 VOLTS AT SELECT
TERMINAL IS "OFF"
+6.5 VOLTS IS "ON"
0 THRU +6.5 VOLTS ON
EA TERMINAL "OFF" → "ON"

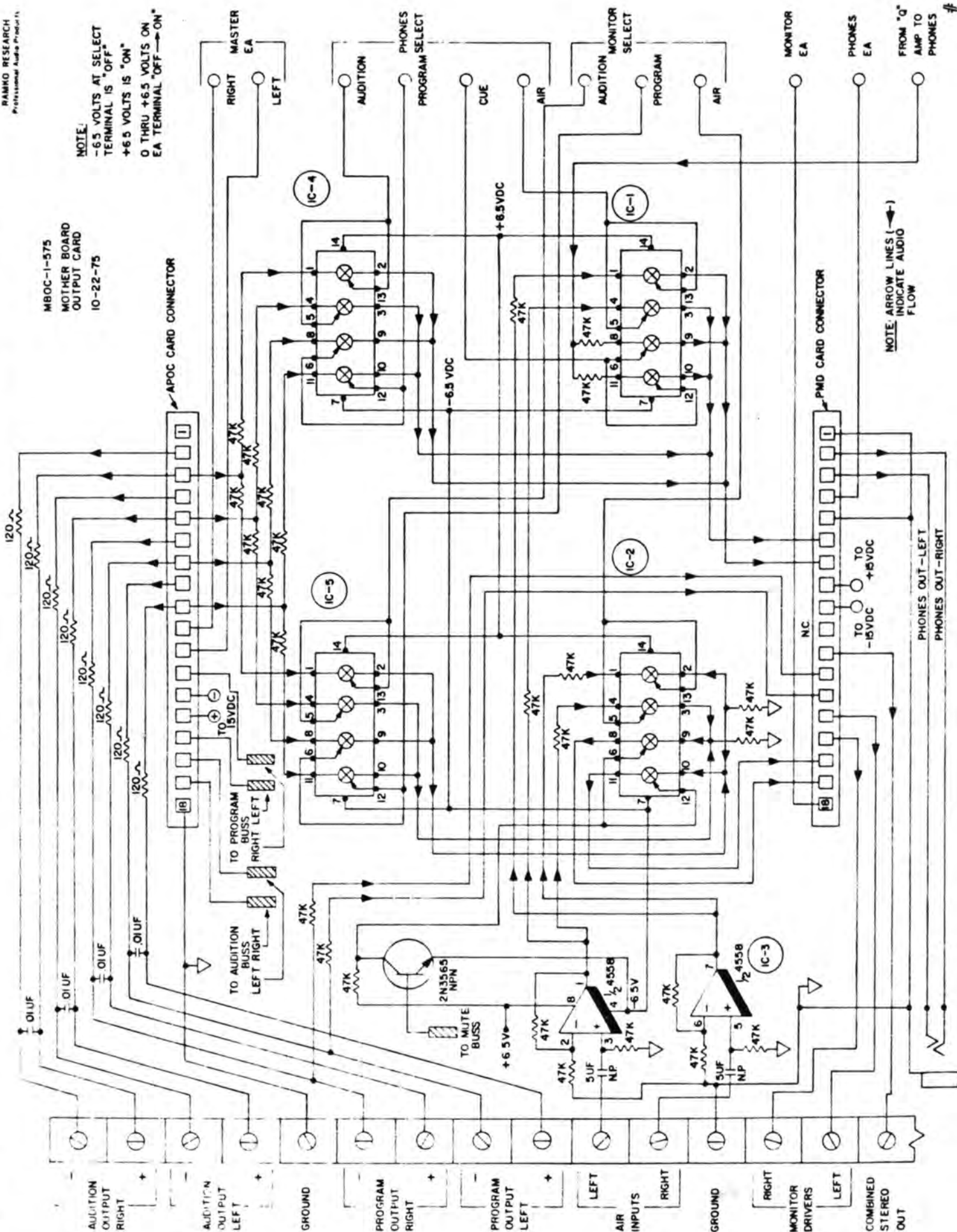

NOTE: ARROW LINES (→) INDICATE AUDIO FLOW

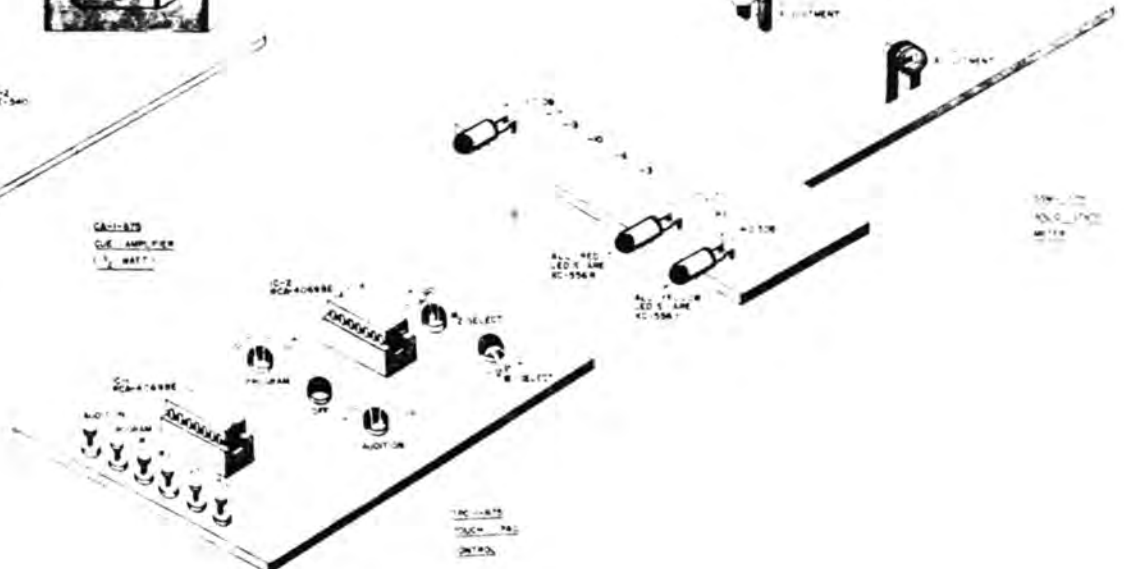
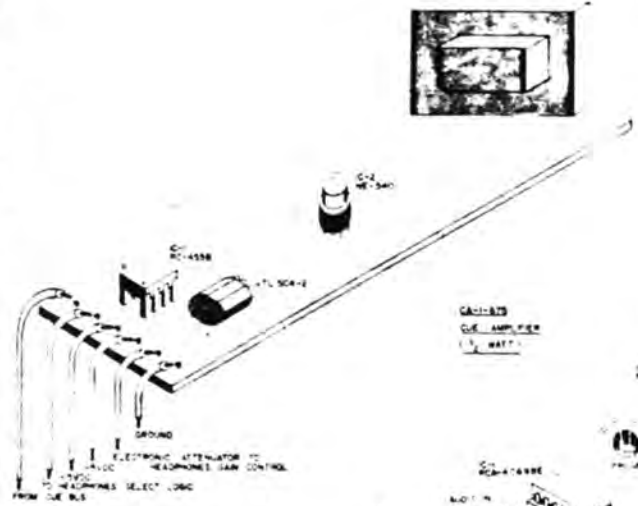
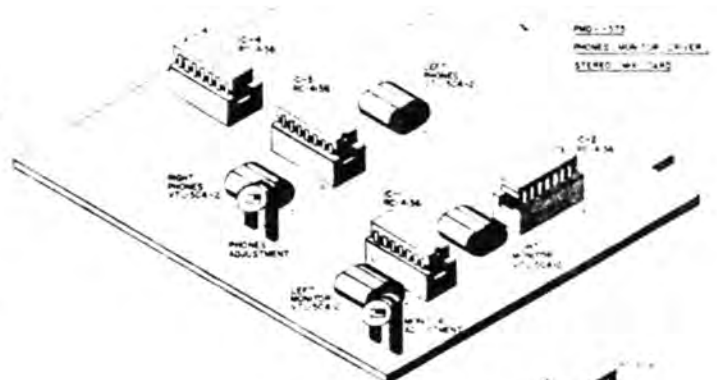
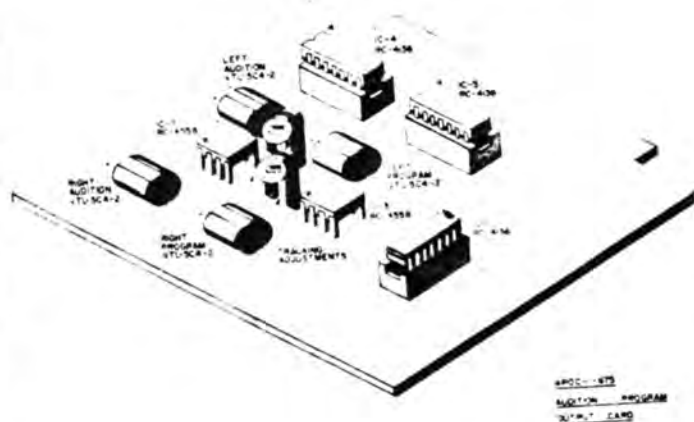
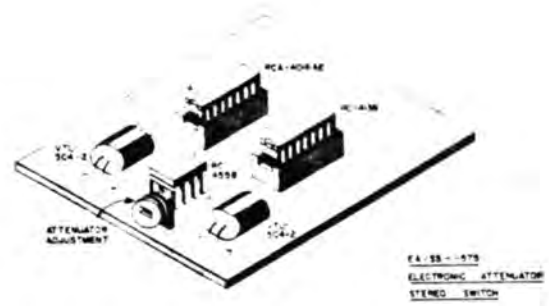
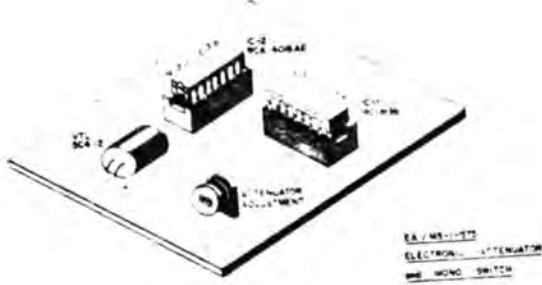
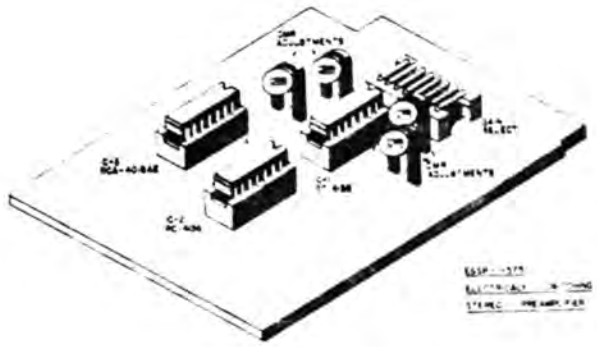
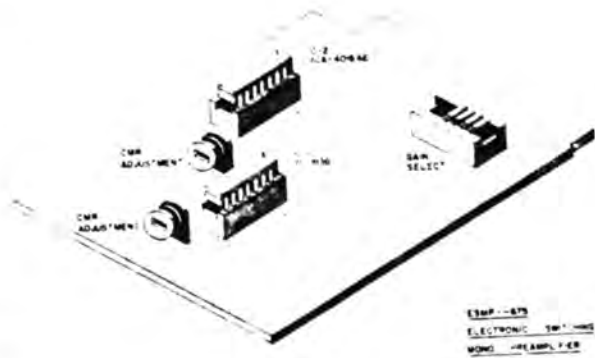

DPS-1-676
 DUAL POWER SUPPLY ($\pm 15V$ DC and $\pm 6V$ DC)
 6-16-76

Alfred V. Vatakyumbe

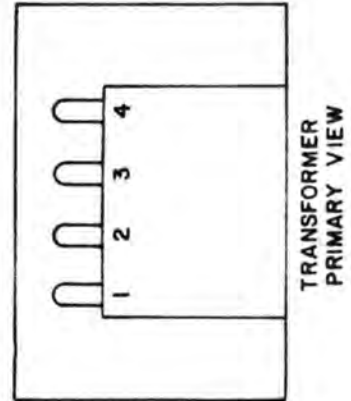
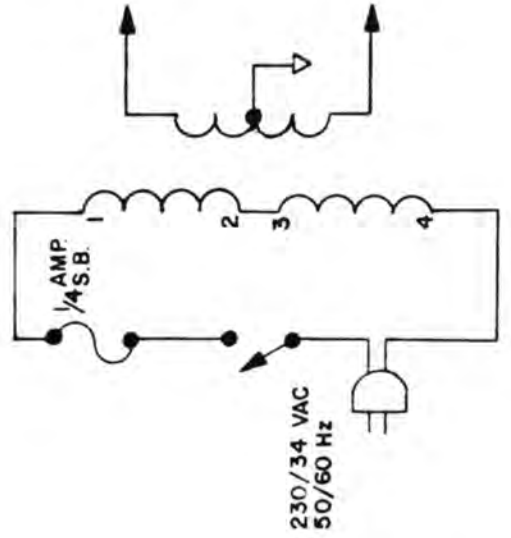
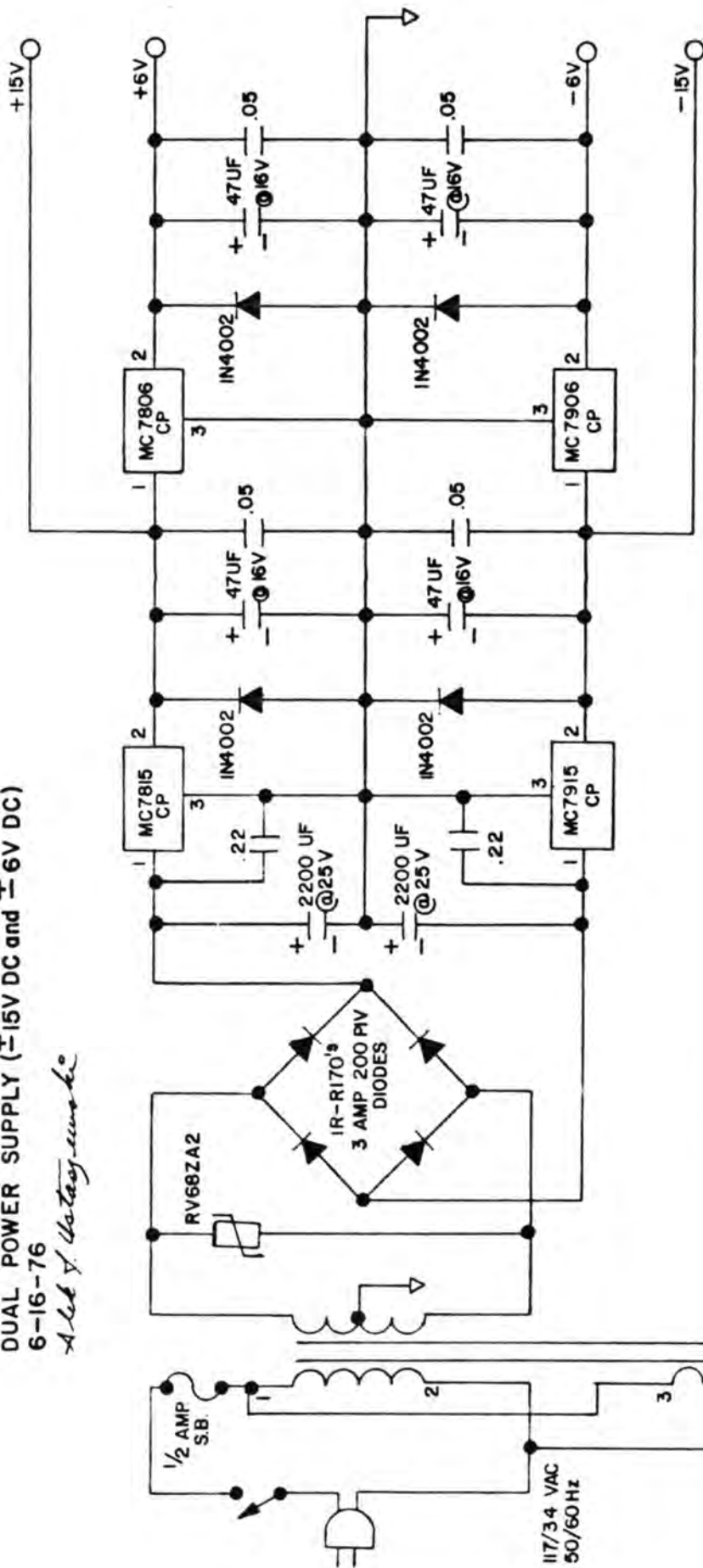

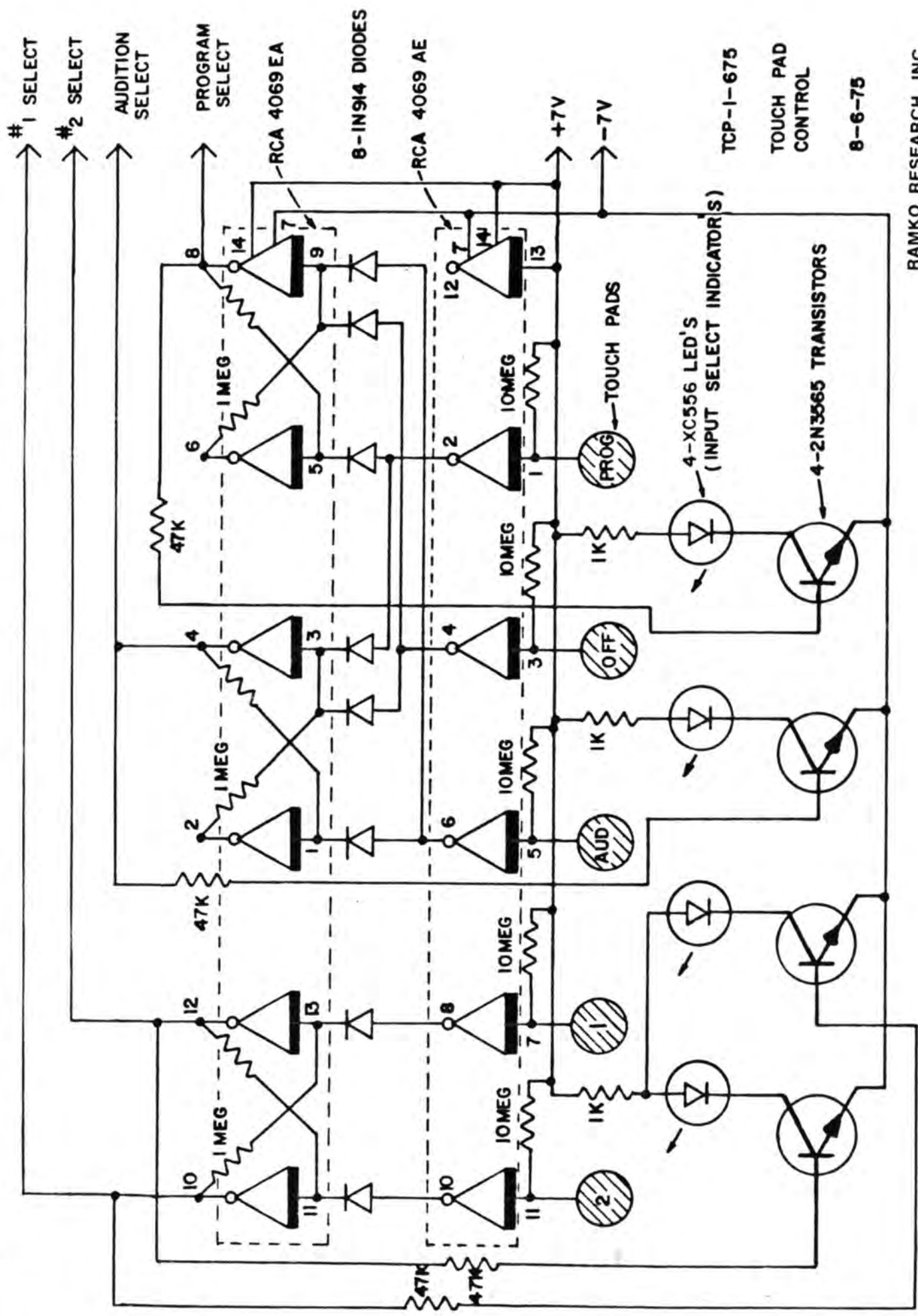

RAMKO RESEARCH, INC.
 11355 "A" FOLSOM BLVD.
 RANCHO CORDOVA, CALIF. 95670
 TEL. (916) 635-3600

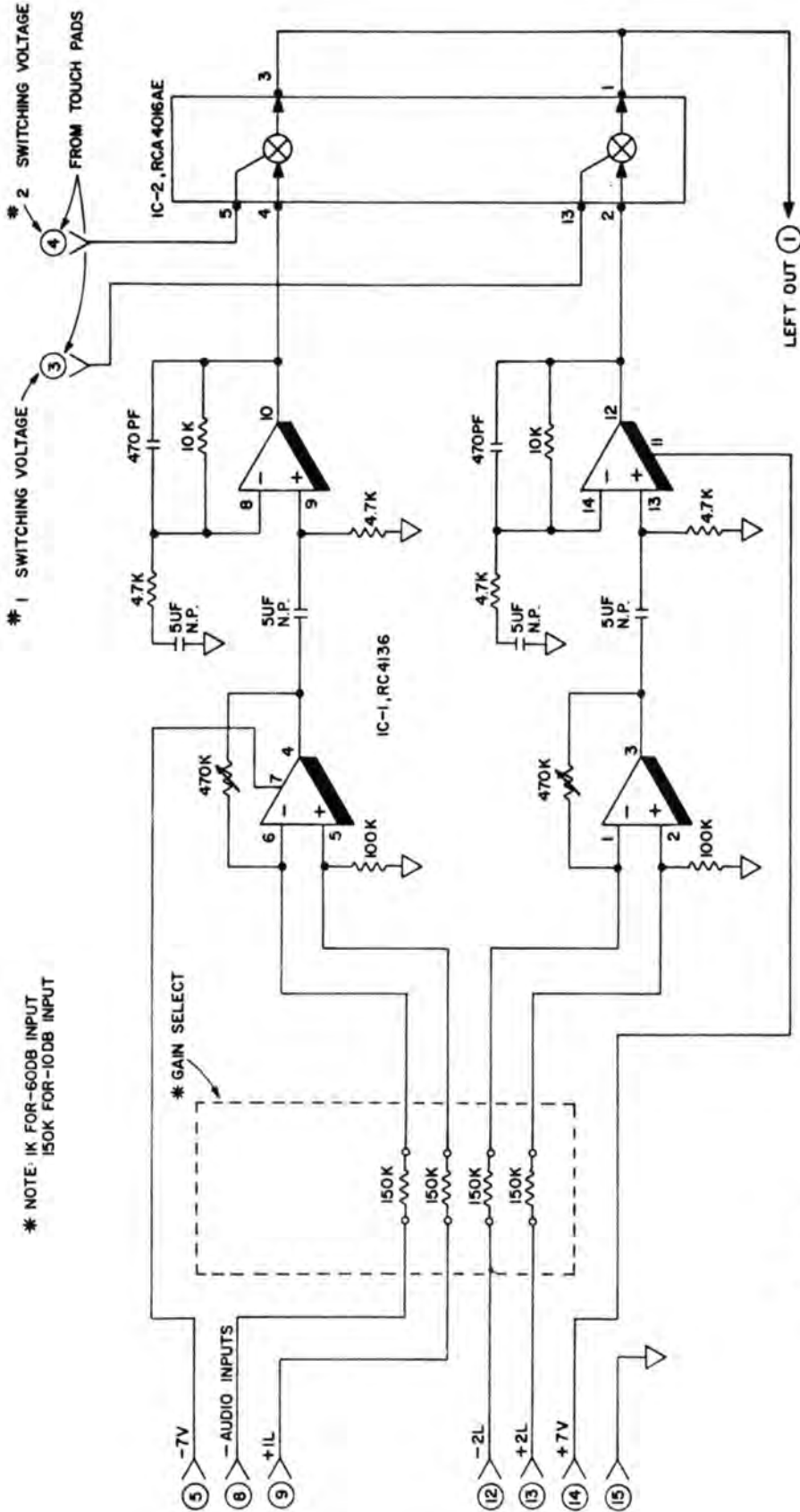

* NOTE: 1K FOR -60DB INPUT
150K FOR -10DB INPUT

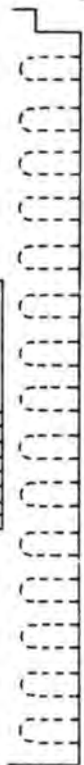
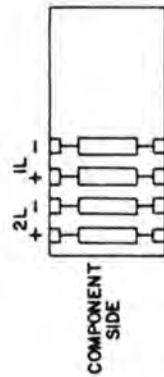
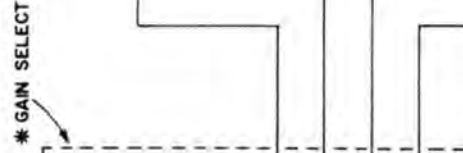

* GAIN SELECT PATCH PANEL

ESMP-1-675
ELECTRICALLY SWITCHED
MONO PREAMPLIFIER
10-23-75

RAMKO RESEARCH
P.O. Box 14
3516 C Lafayette Blvd. #18 95822
SACRAMENTO, CALIFORNIA 95823

FOIL SIDE

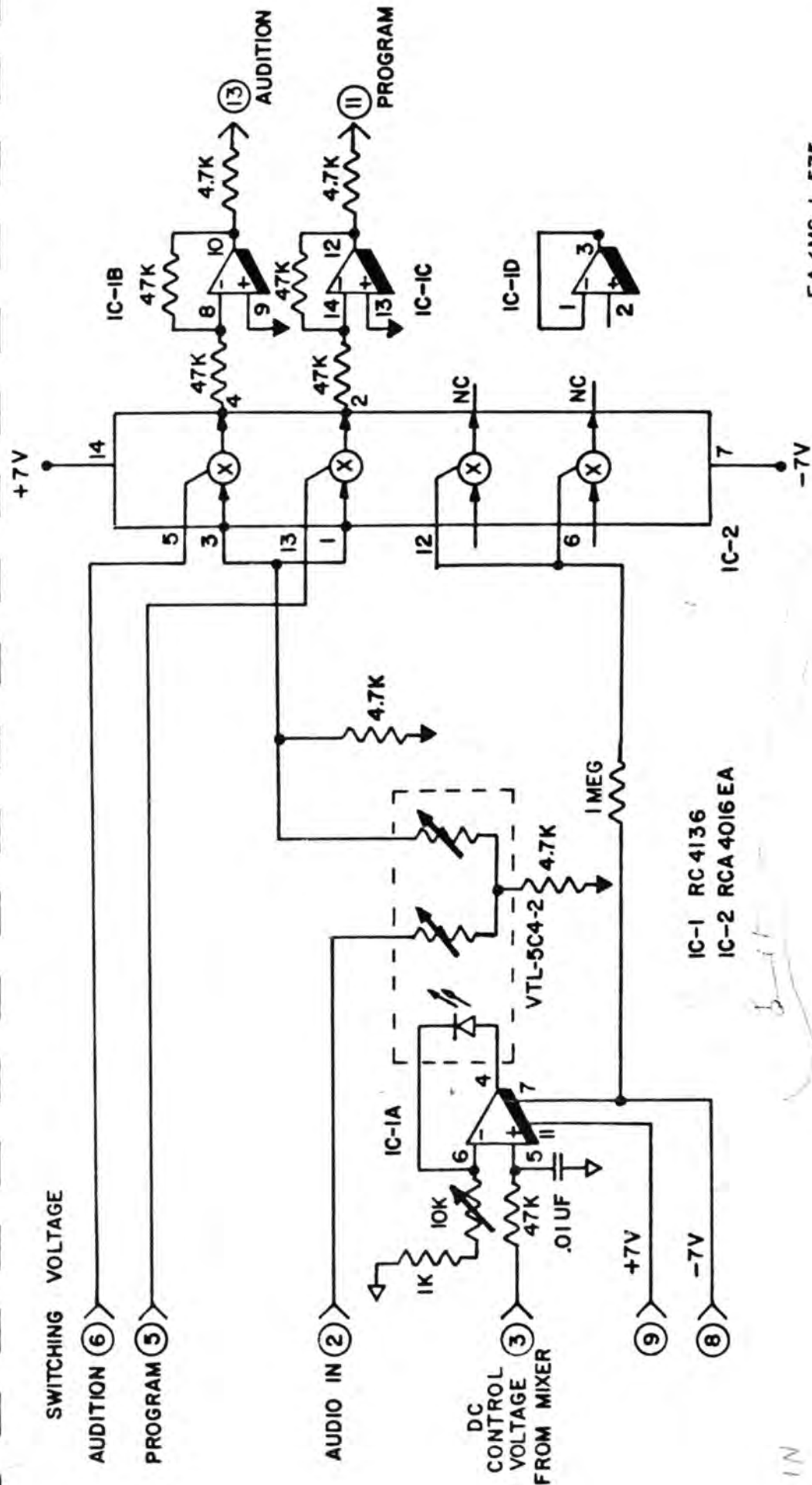

EA/MS-1-575

**ELECTRONIC ATTENUATOR
and MONO SWITCH**

8-19-75

RAMKO RESEARCH, INC.

11355 "A" FOLSOM BLVD.

RANCHO CORDOVA, CALIF. 95670

TEL. (916) 635-3600

FOIL SIDE OF BOARD

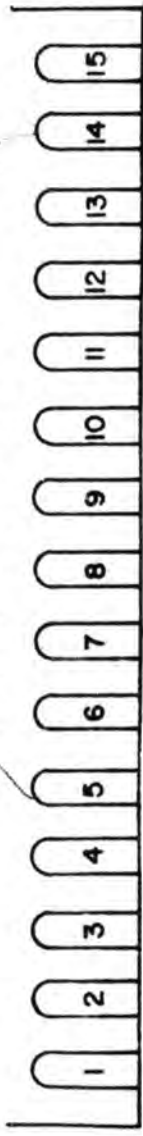

IN
IN
OUT
OUT
GND
+7
-7
Control

PMD, 1-476
 PHONES MONITOR, DRIVER,
 CARD (MONO)
 6-7-76
Adel & Voltey made



ALL RESISTORS = 1/2 W, 5%
 (OR AS NOTED)
 IC1, IC2 = RC4136
 IC3 = 1/2 RC4558

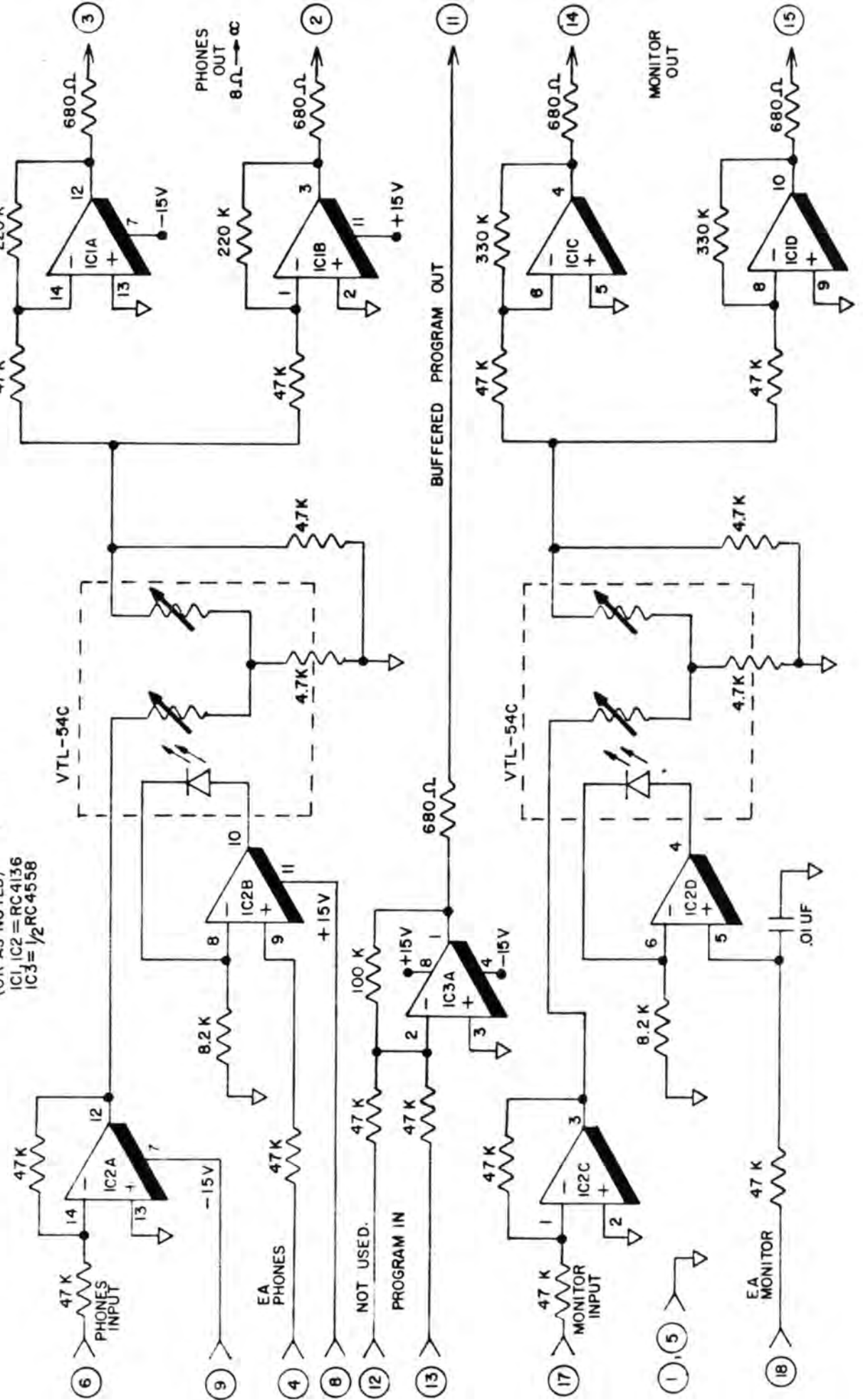

APOC_1-476
 ADDITION and PROGRAM
 OUTPUT CARD (MONO)
 6-4-76

Arch. J. Watson

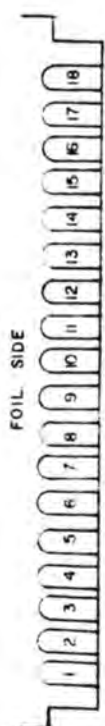

ALL RESISTORS = 1/2 W, 5%
 (OR AS NOTED)
 IC1, IC2 = RC4136

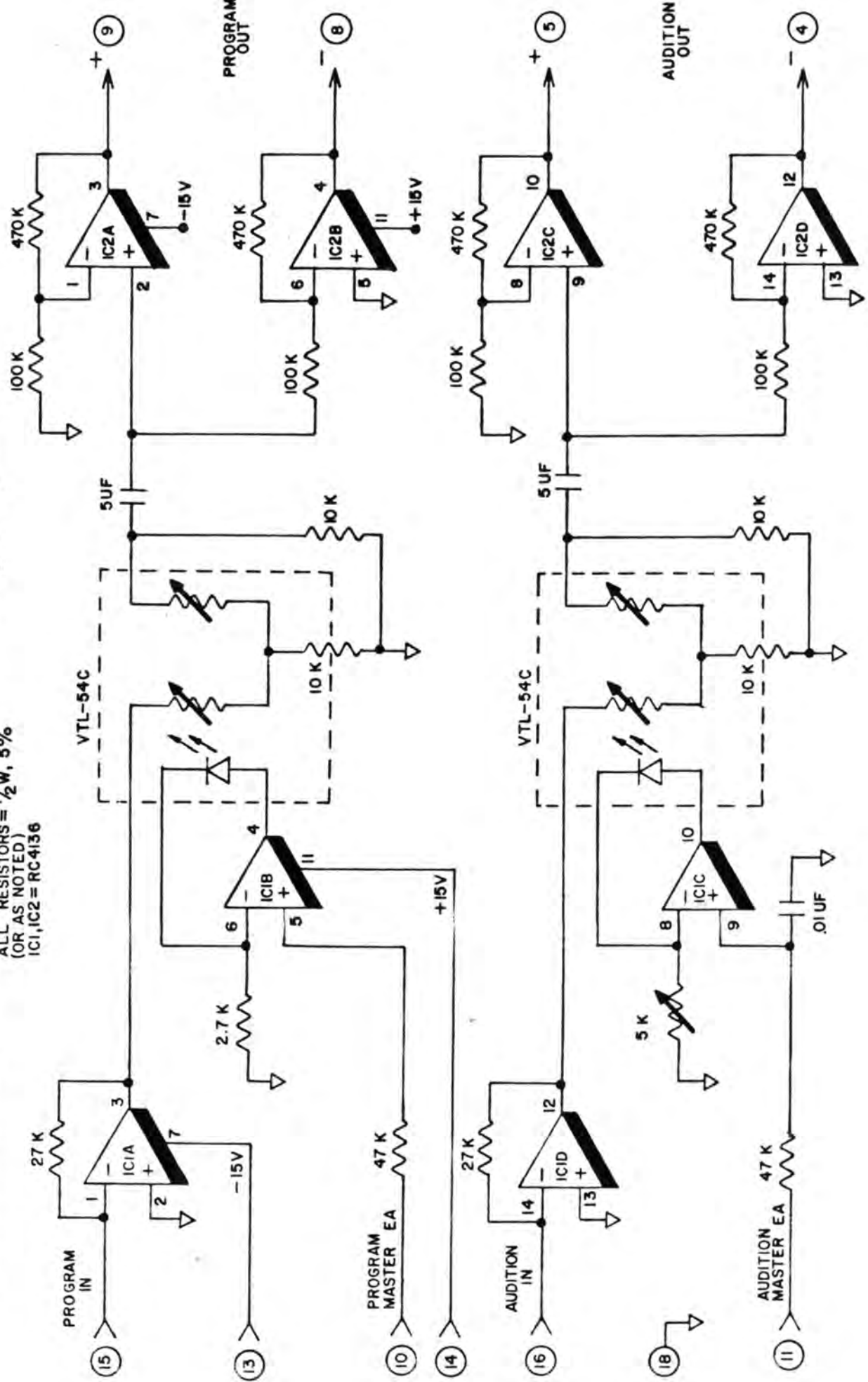

If You Didn't Get This From My Site,
 Then It Was Stolen From...

