



T.M.

project-board

clock/calendar/radio timer

CATALOG NUMBER 277-109



If You Didn't Get This From My Site,
Then It Was Stolen From...
www.SteamPoweredRadio.Com

This package contains a complete circuit card ready for parts to be added. To construct this Project you'll need the following parts :

100000
00227000000

PARTS LIST

SYMBOL		RADIO SHACK		RADIO SHACK		RADIO SHACK	
SYMBOL	DESCRIPTION	QTY.	CAT. NO.	SYMBOL	DESCRIPTION	QTY.	CAT. NO.
C1	220µF/35V Electrolytic Capacitor	1	272-1029	R6-12	330 OHM 1/2 Watt Resistor	7	271-000
C2	01µF (10,000pF) Disc Capacitor	1	272-131	R13	470 OHM 1/2 Watt Resistor	1	271-000
C3	100pF Disc Capacitor	1	272-123	R14-16,20	120K 1/2 Watt Resistor	4	271-000
C4	47pF Disc Capacitor	1	272-121	R17	150 OHM 1/2 Watt Resistor	1	271-000
CR1,4,5	1N4001 Diode	3	276-1101	R22	47K 1/2 Watt Resistor	1	271-000
CR2	Bridge Rectifier	1	276-1151	S1	Rotary Switch 2 Pole, 6 Position	1	275-1386
CR3,6,7,13,23	01N914 Diode	14	276-1620	S2,3,7	SPST Miniature Push-Button Switch	3	275-1547
CR9-12	Subminiature Clear LED	5	276-046	S4,6	SPST Toggle Switch	2	275-324
D1-D6	Common Cathode LED 7 Segment Display	6	276-062	S5	SPDT Toggle Switch, Neutral Center	1	275-325
IC1	Clock/Calendar/Radio Timer Integrated Circuit RS1756	1	276-1756	T1	30Experimenter's Cabinet	1	273-1385
IC2,3	Segment Driver Integrated Circuit RS501	2	276-1701		9V Battery Clip	1	270-261
IC4	Hex Digit Driver Integrated Circuit RS500	1	276-1702		8 AA Cell Battery Holder	1	270-387
K1	Miniature DPDT Relay	1	275-206		AC Socket	1	270-642
LS1	8 OHM Speaker	1	40-245		4 1/2" Spacers	8	270-1383
O1,2,3	Transistor RS2031	3	276-2031		428 Pin Dual-In-Line Socket	1	276-1997
Q4,5,6	Transistor RS2033	3	276-2033		414 Pin Dual-In-Line Socket	9	276-1999
R1	82 OHM 1/2 Watt Resistor	1	271-000		Universal Display Board	1	277-108
R2,18,19,21,23	12K 1/2 Watt Resistor	5	271-000		Project Board (PC Board)	1	277-109
R3	27K 1/2 Watt Resistor	1	271-000		22 Hookup Wire	1	278-1296
R4	250K Trim Potentiometer	1	271-219		Line Cord	1	
R5	1.2K 1/2 Watt Resistor	1	271-000		AA Battery	8	23-453
					Misc. Hardware		

NOTES:

- CR21 and CR22 are optional.
- 10K Resistor is optional for 50K "Trim Pot".
- This is a suggested cabinet to use for this Project.
- These parts are optional.

CLOCK/CALENDAR/ASSEMBLY INSTRUCTIONS

This Clock/Calendar/Timer circuit is versatile enough to satisfy the most avid of kit builders! It combines many features usually found separately in other circuits. These features include: a 28/30/31 day calendar (it automatically counts the correct number of days for each month!); a 12 or 24 hour mode option that can be selected without extensive modifications to the circuit (just add a diode!); an alarm that is a true 24 hour alarm (merely resets the alarm by closing the alarm switch!); and a radio timer that can be set for a sleep mode, wake up mode or a combination of both (it can be used to turn on small appliances too!). Follow the instructions carefully and you will have a Time/Timer device that is highly accurate and dependable.

WARNING: The transformer will have 120 volts across the primary; therefore, it is very important that you insulate the completed project properly.

NOTE: Solder all leads on the copper side of the P.C. board and clip excess wire as you complete each step (See Figures 1 and 2).

1. Installing the jumper wires:
 - a. Cut a 1" piece of wire from the line cord. Strip a ¼" of insulation from each end and insert it in the J1 position.

NOTE: It is recommended that you use the heavier gauge wire on the 120 volt (primary) side of the transformer.

- b. Cut the required number of pieces of hookup wire to the proper lengths for the rest of the jumper positions. Strip a ¼" of insulation from both ends of each jumper wire and insert these wires into their respective positions.

NOTE: When installing the diodes, in steps 2 and 3, be sure to install them in the proper direction; the black band indicates the cathode end (▶ cathode). These diodes are easily damaged, so care must be taken when soldering these into the P.C. board.

2. Install 1N4001 diodes CR1, CR4 and CR5.
3. Install 1N914 diodes CR3, CR6, CR7, CR13 through CR20 and CR23.
4. Mount the Bridge Rectifier CR2. Observe polarity (+ and -).

5. Mount the ¼ watt resistors in their respective locations as follows:
 - a. 82 ohm resistor R1.
 - b. 120K resistors R14 through R16 and R20.
 - c. 27K resistor R3.
 - d. 1.2K resistor R5.
 - e. 330 ohm resistors R6 through R12.
 - f. 470 ohm resistor R13.
 - g. 150 ohm resistor R17.
 - h. 12K resistors R2, R18, R19, R21 and R23.
 - i. 47K resistor R22.

6. Since the 50/60Hz backup circuitry (12V battery supply) operates in conjunction with the display oscillator, more accurate operation may be obtained by using a 50K trim potentiometer in the R4 location. If this accuracy is not required, you may substitute a 10K ¼ watt resistor. The following procedures apply:

- a. Install the "trim pot" in the R4 location, or—
- b. Install the 10K ¼ watt resistor between holes X and Y.

7. Mount the capacitors in their respective locations as follows:
 - a. 220uF/35V capacitor C1. Observe polarity (+ and -).
 - b. .01uF capacitor C2.
 - c. 100pF capacitor C3.
 - d. 47pF capacitor C4.

8. Mount RS2031 transistors Q1, Q2 and Q3.

9. Mount RS2033 transistors Q4, Q5 and Q6.

10. Mount the 28 pin dual-in-line socket.

11. Mount three 14 pin dual-in-line sockets.

12. Install the DPDT relay K1.

13. Cut a piece of wire from the line cord long enough to extend from the AC SOCKET holes (P.C. board) to the AC socket (to be mounted on the back panel of the case). The length will depend on the case style you wish to mount your clock in. Make a 2" cut through the groove in the insulation. Strip a ¼" of insulation from each wire end and insert the ends in the AC SOCKET holes.

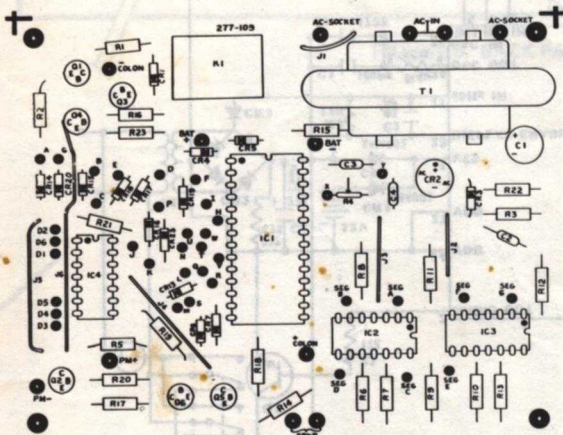

FIGURE 1. TOP OF P.C. BOARD

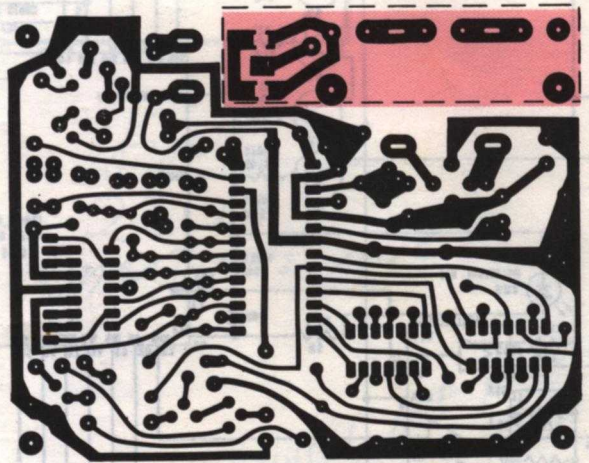

FIGURE 2. X-RAY VIEW OF P.C. BOARD

NOTE: Before installing the line cord, insert a grommet (RS CAT. NO. 64-3025) into an appropriate hole in the back panel. Then thread the line cord through the hole and tie a single knot in the cord, inside the case, to act as a strain relief.

14. Install the line cord in the AC IN terminals.

15. Install the 12V/300mA transformer T1. CAUTION: To reduce shock hazard you should place insulating tape across the AC and relay terminals as outlined in Figure 2.

16. Install the 9V battery clip—red wire to BAT+ and black wire to BAT—.

17. Insert hookup wire into the speaker holes. Note: Keep in mind the location of the speaker after it is mounted.

18. If you wish to have a 24 hour clock, merely add another diode (CR21) between points V and H. However, you will lose the blinking colons and the PM indicator.

For Countries with 240VAC/50Hz only:

19. Substitute a 240VAC at 50Hz/12VAC, 300mA transformer (RS CAT. NO. 273-9007) for the one called out in the Parts List.

20. For 50Hz operation, add diode CR22 between points I and W.

3. Mount four light emitting diodes (LED's). Be sure to install them with the diodes in series (cathodes positioned as shown in Figure 3). They form the colons (:) separating the hours digits from the minutes digits and the minutes digits from the seconds digits.

4. Mount the fifth LED, CR8, as illustrated in Figure 3. This is the PM indicator. The anode end will be connected to the PM+ output from the PC board and the cathode end to the PM— output.

FINAL ASSEMBLY

NOTE: The following assembly procedures require the use of the case that is listed in the Parts List. This is a suggested layout only. You may use any case you desire provided that you follow the point-to-point wiring as shown in Figure 5.

1. Mount the switches on the back panel of the case according to your own desires, or according to our layout as shown in Figure 5. Be careful to allow clearance for the relay and transformer.

2. Plan the location of the PC board on the base panel of the case—allow room for the Speaker and the Battery Holder.

3. Mount the Speaker.

X-RAY VIEW

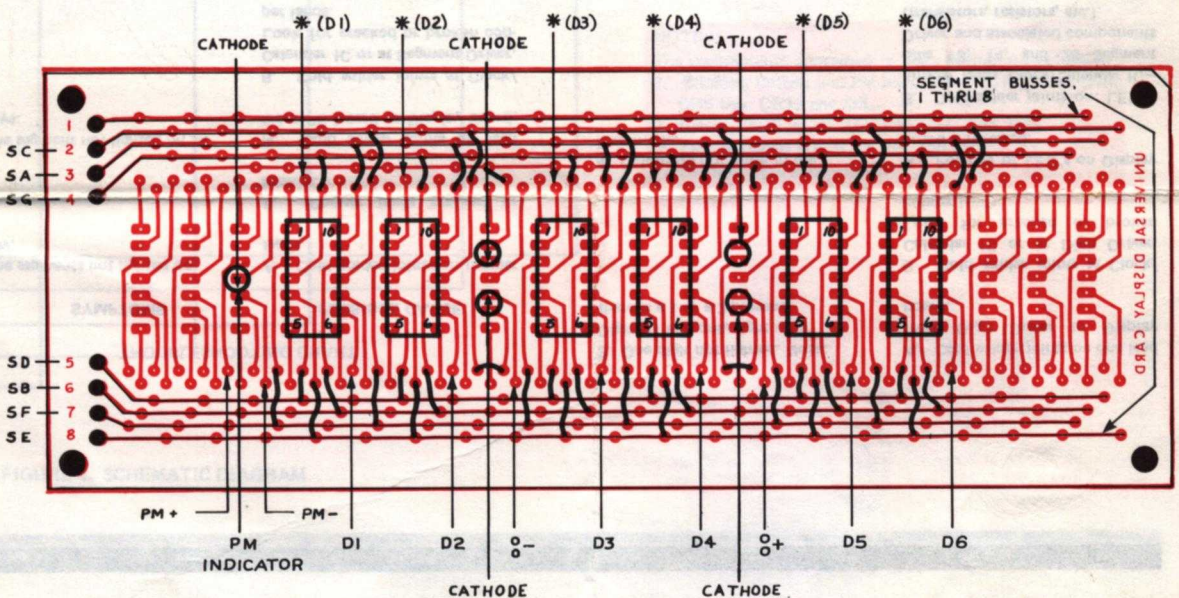

FIGURE 3. UNIVERSAL DISPLAY BOARD

NOTE: * Optional inputs for Digit Drivers.

ASSEMBLY INSTRUCTIONS FOR THE UNIVERSAL DISPLAY BOARD

The basic idea is to connect corresponding segments from each digit display together on a common run, or segment buss (see Figure 3). For example, the "A" segments from each digit are connected together via the number 3 (SA) buss; likewise for the "B" segments, number 6 (SB) through the G segments, number 4 (SG). The seven segment busses are then connected with hookup wire to the proper segment driver outputs from the PC board.

1. Connect the jumper wires as shown on the Universal Display Board drawing (Figure 3). The drawing is an X-ray view (ie, looking "through" the board) to aid in proper orientation. You will need approximately 50 pieces of hookup wire; each one no more than 3/4" long. Strip the insulation from these pieces and mount them as shown in Figure 3. These wires mount on the side opposite the printed circuit and pass through the holes provided to connect to the printed circuit.

NOTE: In the following step you may install six 14 pin dual-in-line sockets on the board or you can mount the LED displays directly to it.

2. Mount the LED digital displays on the same side as the jumpers. Be sure to position them as shown in Figure 3 (note the location of pin 1)

4. You may, at this time mount the display board on the front panel using 1/2" spacers; however, it is easier to solder the hookup wire to it if it is left free temporarily.

5. Solder the Speaker leads to the Speaker.

6. With hookup wire connect the following display segment busses, SF, SE, SB, colon+, colon-, PM Indicator+, and PM Indicator- to their corresponding outputs (holes) on the PC board.

7. Connect the following display segment busses, D1 through D6, SC, SG, and SA. Note: The digit drivers may be connected to the optional inputs (Figure 3).

8. Use hookup wire between the following points (see Figure 5):

P.C. BOARD

R(PIN 11)
E(PIN 5)
S(PIN 12)
Q(PIN 10)
D(PIN 5)
U(PIN 7)
G(PIN 4)
T(PIN 8)
F(PIN 6)
N(PIN 8)
B(PIN 5)
P(PIN 9)
C(PIN 5)
A(PIN 4)
J(PIN 8)
K(PIN 9)
L(PIN 10)
M(PIN 12)

BACK PANEL

S5(BOTTOM TERMINAL)
S5(CENTER TERMINAL)
S5(TOP TERMINAL)
S4(BOTTOM TERMINAL)
S4(TOP TERMINAL)
S7(BOTTOM TERMINAL)
S7(TOP TERMINAL)
S6(BOTTOM TERMINAL)
S6(TOP TERMINAL)
S2(BOTTOM TERMINAL)
S2(TOP TERMINAL)
S3(BOTTOM TERMINAL)
S3(TOP TERMINAL)
S1(TERMINAL 1)
S1(TERMINAL 6)
S1(TERMINAL 5)
S1(TERMINAL 4)
S1(TERMINAL 3)

NOTE: If 24 Hr operation and 50Hz operation are not used, points V, H, I and W will not be used.

9. Install the Integrated Circuits (IC's) in their respective sockets.

CAUTION: These devices are extremely susceptible to damage from static charges. We recommend that you handle them by the ends. **DO NOT TOUCH THE PINS!**

NOTE: A dot or indentation at one end indicates pin 1. Ensure that the IC's are positioned as shown in Figure 1.

- a. Insert IC-1 (RS1756). Be sure to align the pins with the socket holes. They are made of soft metal and will bend very easily.
- b. Insert IC-2 and IC-3 (RS501) and IC-4 (RS500) using the same precautions as in step a.

10. Before mounting the PC board and Display board, carefully check all solder connections. Make sure that there are no cold solder joints and that solder does not bridge across adjacent copper lands. Check that all hookup wiring is correct (point-to-point).

11. We suggest that you plug in to a power source to make sure all segments of the LED displays are energized. A word of caution: Be sure that the unit is well insulated. Do not place the unit on a metal surface and avoid touching any bare contact points.

12. On initial application of power, the board will display all eights, or random numbers. To start the counting of the clock, depress either S2 or S3. Normally, digits 2 and 4 will not light until S2 or S3 is depressed and held.

13. Rotate switch S1 to each position. If the clock does not count, or a segment does not light, refer to the troubleshooting chart.

14. Using 1/8" spacers, mount the PC board on the base panel of the case.

15. Again using 1/8" spacers, mount the Display board on the front panel.

OPERATING INSTRUCTIONS FOR THE CLOCK/CALENDAR

1. When power is initially applied, the Clock/Calendar will display all 8's. Depressing either S2 (Min/Day) or S3 (Hr/Mo) will start the counting of the clock; however, D2 and D4 will be blanked.

2. To set the clock, rotate switch S1 (Counter Select) to Set Clock. Depress S3—the seconds digits will revert to 00 and the hours digit will advance at a 1Hz rate. Depress S2 and the minutes digits will advance at a 1Hz rate. Rotate S1 to the Run position. Note: Setting the digits of any counter will not affect the other digits of the counter or the contents of any other counter. The time displayed will hold until the switch is moved from this position. This feature enables you to synchronize

your clock by setting it ahead of the real time; and, when real time coincides with Set Time, rotate S1 to Run position.

3. To set the calendar, rotate S1 to Set Cal and perform the same procedures as outlined in step 2. The digits will advance as before with the following exceptions:

- a. The colons, PM Indicator and seconds digits will be blanked.
- b. The Hr/Mo digits will advance only to 12, then revert to 1. The Min/Day digits will advance to 31.
- c. Rotate S1 to Run. The Min/Day digits will advance to 28, 30 or 31 days according to the month. February 29 must be set manually. The calendar will automatically count from February 29 to March 1.

4. To set the alarm, rotate S1 to Set Alarm (the seconds digits will be blanked). Advance the digits to the desired setting—up to 24 hours—and position S6 (Alarm On/Off) to On. Then rotate S1 to the Run position. At the preset time the alarm will sound. It can be turned off with S6 at any time; but, since the Alarm Time and the real time remain coincident for 60 seconds, the alarm cannot be reset until then. Placing S6 to On again will allow the alarm to sound at the same preset time 24 hours later.

5. When the alarm sounds, you can depress S7 (Snooze switch) for an extra 10 minutes' sleep. You may get as many "10 minutes' extra sleep" as you desire by depressing S7 until S6 is moved to Off.

6. To set the Timer for a radio or a small appliance (less than 600 watts) rotate S1 to Set Radio (the seconds digits will be blanked). Depress S3 and the hours digit will count down from 9 to 0. Depress S2 and the minutes digits will count down from 59 to 0. Set in the length of time (hours and/or minutes) you want the radio to play. Place S4 (Radio On/Off) in the On position and rotate S1 to Run.

7. You have a choice of three timer modes:

- a. If you want the radio to turn on and play for the time set in, place S5 (Mode A & B) switch in the up position and rotate S1 to Run. The radio, or appliance, will turn off automatically at the end of the time set in. Label this position—SLEEP.
- b. If you wish to wake up to music, place S5 in the down position. The radio will come on at the alarm time and play for the preset time then turn off automatically. You may turn the radio off with S6 at any time prior to the preset time. Label this position RADIO WAKE UP.
- c. If you want the radio to play for the time set in, turn off automatically, then come back on again at the alarm time, place S5 in the center position. When it comes on at the alarm time, it will play until turned off manually with S4. Label this position BOTH.

8. Label the rest of the controls according to Figure 6.

9. If you have mounted the "trim pot" in the R4 location, you will want to adjust the 50/60Hz backup circuitry (battery backup):

NOTE: When on battery power only, the displays will be blanked (to extend the life of the batteries) but the clock will continue counting.

- a. Operate the clock on battery power only (line cord unplugged) for 10 seconds then plug in the line cord again. Use a stop watch or sweep second hand of a standard watch to compare the elapsed time of the clock to that of the watch. If the clock runs faster or slower, adjust R4 accordingly. (To increase frequency, rotate R4 clockwise).
- b. Gradually increase the operating time on battery power up to 30 seconds, adjusting R4 each time. You should be able to get an accuracy of within one second per minute.
- c. If you have a frequency counter you can adjust R4 so that D1 is at 1.05KHz for 60Hz operation and at 875Hz for 50Hz operation. (This should also be done on battery power only).

TANDY CORPORATION

DESIGN

U.S.

THE QUALITY OF TANDY

MILTON ROAD

NEW BRUNSWICK

NEW JERSEY STAFFS 07032 NJ

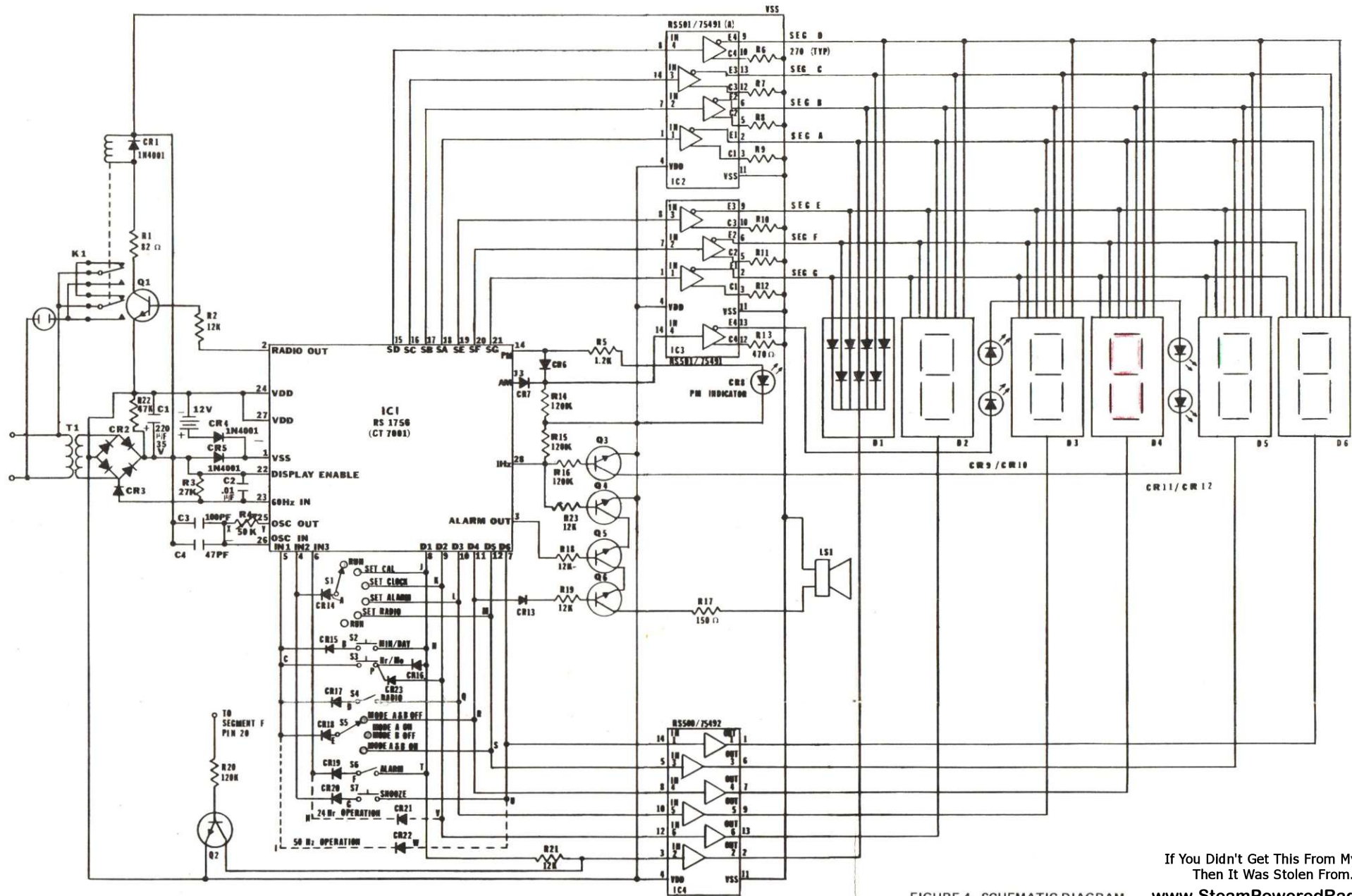

- NOTES:**
 The components contained in each option are as follows:
 1. Blinking Colons and PM indicator—R5, R13 thru R16, CR6 thru CR12 and Q3.
 2. Battery Back up—8 1.5V Batteries, CR4, CR5.
 3. Zero Suppress D1—R20, R21 and Q2.
 4. 24 Hour Operation—CR21.
 5. 50Hz Operation—CR22.

FIGURE 4. SCHEMATIC DIAGRAM

If You Didn't Get This From My Site,
 Then It Was Stolen From...
www.SteamPoweredRadio.Com

Handwritten signature and date: 10/1/2007

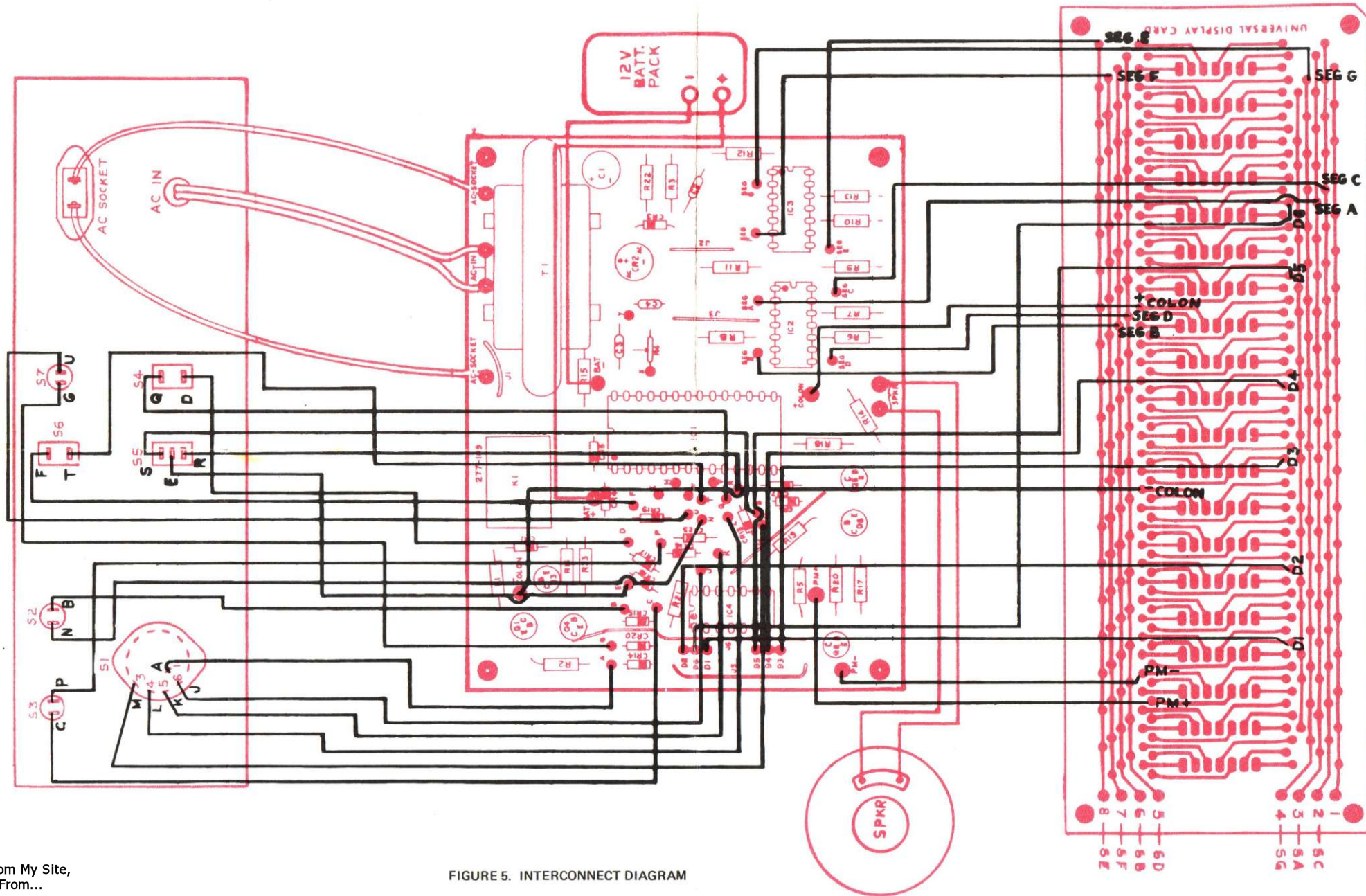

FIGURE 5. INTERCONNECT DIAGRAM

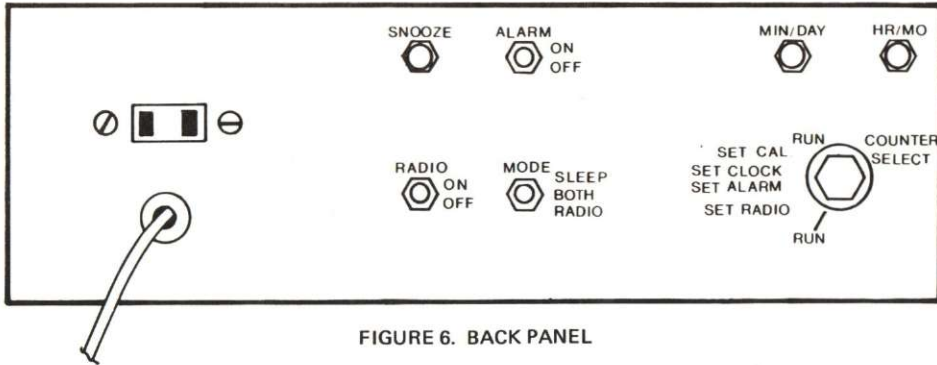



FIGURE 6. BACK PANEL

TROUBLESHOOTING CHART

SYMPTOMS	POSSIBLE CAUSE
1. One segments not lighted on display.	A. Cold solder joints on jumper leads. B. Copper lands cracked or broken.
2. One segment not lighted on all displays.	A. Cold solder joints on lead from PC board to Display board. B. Cold solder joints at Clock/Calendar IC or at Segment Driver. Look for cracked or broken copper lands. C. Switch Segment Driver IC's. If blanked segment shows up in a different position, replace defective driver.
3. One digit not lighted. Note: Digit D1 will only light up if there is a 1 or a 2 present.	A. Cold solder joints on one lead from Digit Driver to Display board. B. Cold solder joints at Clock/Calendar IC or at Digit Driver. Look for cracked or broken copper lands.
4. Colons do not blink in the Run mode.	A. Polarity of LED's on Display board is reversed. B. Cold solder joints on: LED's, jumper leads, Clock/Calendar IC—pins 13, 14, and 28—Segment Driver and associated components (transistors, resistors, etc.). C. Copper lands cracked or broken.
5. One, or more, Display functions (Set Clock, Set Cal, etc.) does not work.	A. With a voltmeter on ohms scale, check 1N914 diodes for good front to back ratio (high resistance—anode to cathode, low resistance—cathode to anode).

RADIO SHACK  A TANDY CORPORATION COMPANY
 U.S.A.: FORT WORTH, TEXAS 76107
 CANADA: BARRIE, ONTARIO, CANADA L4M 4W5

PRINTED IN USA

If You Didn't Get This From My Site,
 Then It Was Stolen From...
www.SteamPoweredRadio.Com

Handwritten notes:
 LEFT - RIGHT
 LEFT on Vista was
 RIGHT on PALM AVE
 MONTANA on LEFT
 TO END
 near House

Handwritten note:
 1 1/2"

TANDY CORPORATION

AUSTRALIA
 280-316 VICTORIA ROAD
 RYDALMERE, N.S.W. 2116

BELGIUM
 PARC INDUSTRIEL DE NANINNE
 5140 NANINNE

U K
 BILSTON ROAD
 WEDNESBURY, STAFFS WF10 7JN