

REVISIONS		
ZONE	LTR	DESCRIPTION
	A	RELEASED
		DATE
		12-13-79
		APPROVED
		R2

REAR VIEW  
# 24-46

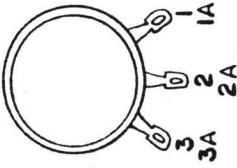

RI FRONT SECTION - LEFT  
RIA REAR SECTION - RIGHT

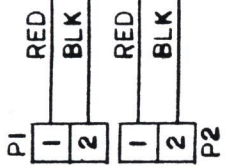
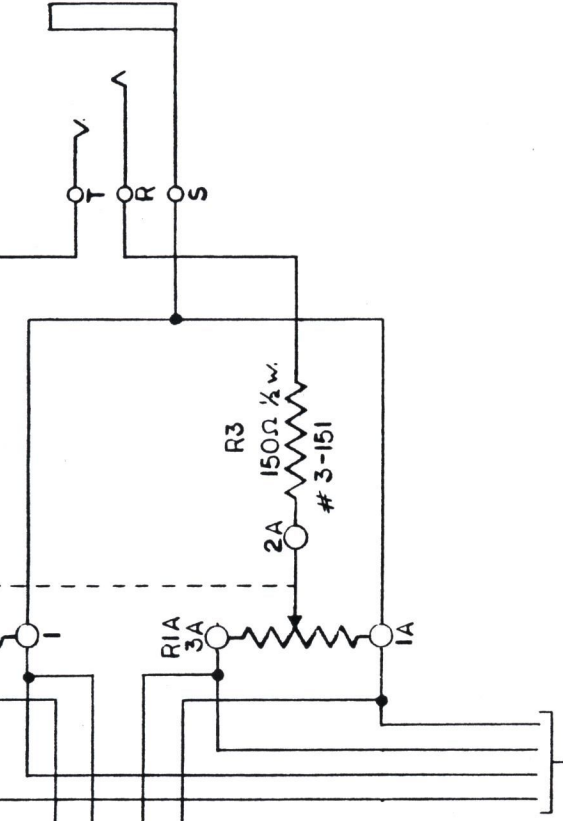

FROM CROWN D-75  
POWER AMP

1. P1 + P2 ARE DOUBLE BANANA, SUPPLIED WITH EACH CROWN AMP
2. PROVIDE STRAIN RELIEF ANCHOR FOR WIRING WITH PANDUIT
3. WIRING IS BELDEN #8451, SHIELD IS NOT USED. LENGTH TO BE SPECIFIED FOR EACH PROJECT

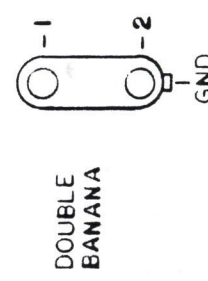

DOUBLE BANANA

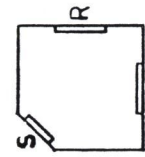

REAR VIEW  
#17-22

#17-22  
PHONE JACK

TO OTHER 99-103  
PANELS

If You Didn't Get This From My Site,  
Then It Was Stolen From...  
www.SteamPoweredRadio.Com

**PACIFIC RECORDERS AND ENGINEERING CORP.**  
HEADPHONE LEVEL AND OUTPUT PANEL CABINET MOUNT

CONTRACT NO. \_\_\_\_\_  
DRAWN R. Thompson 11-12-79  
CHECKED JPN 12/31/79

UNLESS OTHERWISE SPECIFIED DIMENSIONS ARE IN INCHES FRACTIONS DECIMALS ANGLES  
XX ± ±  
.XXX ± ±  
MATERIAL \_\_\_\_\_  
FINISH \_\_\_\_\_

DO NOT SCALE DRAWING

SIZE B  
CODE IDENT NO. 99-103  
KEY A

SCALE SHEET 1 OF 2



4 3 2 1

REVISIONS		DATE	APPROVED
ZONE	LTR	DESCRIPTION	

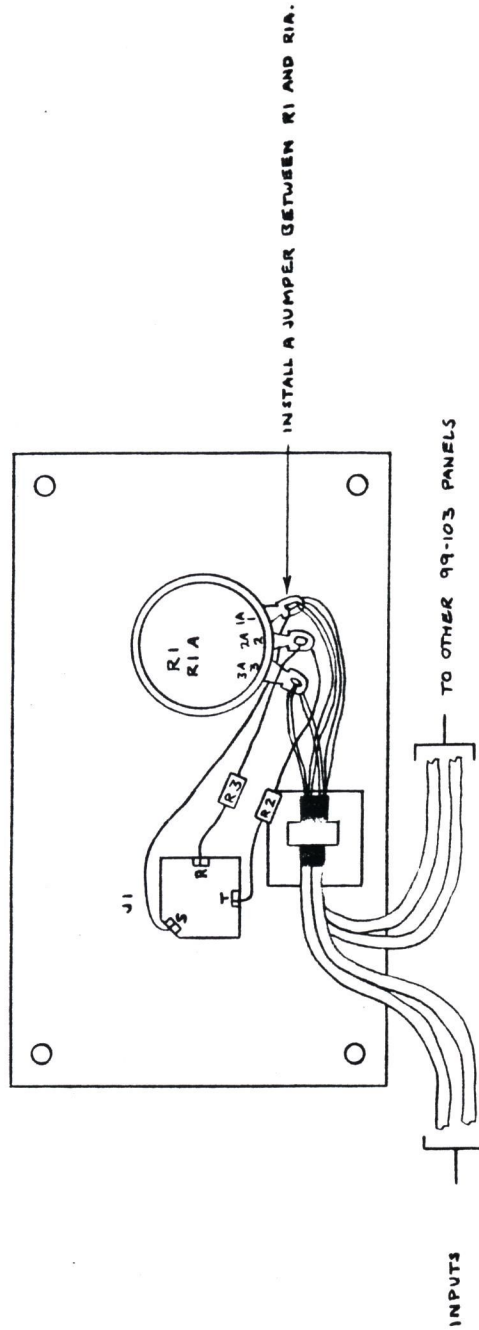

If You Didn't Get This From My Site,  
Then It Was Stolen From...  
[www.SteamPoweredRadio.Com](http://www.SteamPoweredRadio.Com)

<b>PACIFIC RECORDERS AND ENGINEERING CORP.</b> HEADPHONE LEVEL AND JACK PANEL CABINET MOUNT		CONTRACT NO. APPROVALS DRAWN <i>R. Thomas</i> CHECKED	DATE 5-23-80
UNLESS OTHERWISE SPECIFIED DIMENSIONS ARE IN INCHES FRACTIONS DECIMALS ANGLES $\frac{1}{16}$ .031 $\pm$ $\frac{1}{32}$ .015 $\pm$ $\frac{1}{64}$ .008 $\pm$ $\frac{1}{8}$ .125 $\pm$ $\frac{1}{4}$ .250 $\pm$ $\frac{1}{2}$ .500 $\pm$ $1$ 1.000 $\pm$ $2$ 2.000 $\pm$ $3$ 3.000 $\pm$ $4$ 4.000 $\pm$ $6$ 6.000 $\pm$ $8$ 8.000 $\pm$ $10$ 10.000 $\pm$ $12$ 12.000 $\pm$ $14$ 14.000 $\pm$ $16$ 16.000 $\pm$ $18$ 18.000 $\pm$ $20$ 20.000 $\pm$ $24$ 24.000 $\pm$ $28$ 28.000 $\pm$ $32$ 32.000 $\pm$ $36$ 36.000 $\pm$ $40$ 40.000 $\pm$ $48$ 48.000 $\pm$ $56$ 56.000 $\pm$ $64$ 64.000 $\pm$ $72$ 72.000 $\pm$ $80$ 80.000 $\pm$ $96$ 96.000 $\pm$ $120$ 120.000 $\pm$ $144$ 144.000 $\pm$ $168$ 168.000 $\pm$ $192$ 192.000 $\pm$ $216$ 216.000 $\pm$ $240$ 240.000 $\pm$ $288$ 288.000 $\pm$ $336$ 336.000 $\pm$ $384$ 384.000 $\pm$ $432$ 432.000 $\pm$ $480$ 480.000 $\pm$ $576$ 576.000 $\pm$ $672$ 672.000 $\pm$ $768$ 768.000 $\pm$ $864$ 864.000 $\pm$ $960$ 960.000 $\pm$ $1008$ 1008.000 $\pm$ $1152$ 1152.000 $\pm$ $1296$ 1296.000 $\pm$ $1440$ 1440.000 $\pm$ $1584$ 1584.000 $\pm$ $1728$ 1728.000 $\pm$ $1872$ 1872.000 $\pm$ $2016$ 2016.000 $\pm$ $2160$ 2160.000 $\pm$ $2304$ 2304.000 $\pm$ $2448$ 2448.000 $\pm$ $2592$ 2592.000 $\pm$ $2736$ 2736.000 $\pm$ $2880$ 2880.000 $\pm$ $3024$ 3024.000 $\pm$ $3168$ 3168.000 $\pm$ $3312$ 3312.000 $\pm$ $3456$ 3456.000 $\pm$ $3600$ 3600.000 $\pm$ $3744$ 3744.000 $\pm$ $3888$ 3888.000 $\pm$ $4032$ 4032.000 $\pm$ $4176$ 4176.000 $\pm$ $4320$ 4320.000 $\pm$ $4464$ 4464.000 $\pm$ $4608$ 4608.000 $\pm$ $4752$ 4752.000 $\pm$ $4896$ 4896.000 $\pm$ $5040$ 5040.000 $\pm$ $5184$ 5184.000 $\pm$ $5328$ 5328.000 $\pm$ $5472$ 5472.000 $\pm$ $5616$ 5616.000 $\pm$ $5760$ 5760.000 $\pm$ $5904$ 5904.000 $\pm$ $6048$ 6048.000 $\pm$ $6192$ 6192.000 $\pm$ $6336$ 6336.000 $\pm$ $6480$ 6480.000 $\pm$ $6624$ 6624.000 $\pm$ $6768$ 6768.000 $\pm$ $6912$ 6912.000 $\pm$ $7056$ 7056.000 $\pm$ $7200$ 7200.000 $\pm$ $7344$ 7344.000 $\pm$ $7488$ 7488.000 $\pm$ $7632$ 7632.000 $\pm$ $7776$ 7776.000 $\pm$ $7920$ 7920.000 $\pm$ $8064$ 8064.000 $\pm$ $8208$ 8208.000 $\pm$ $8352$ 8352.000 $\pm$ $8496$ 8496.000 $\pm$ $8640$ 8640.000 $\pm$ $8784$ 8784.000 $\pm$ $8928$ 8928.000 $\pm$ $9072$ 9072.000 $\pm$ $9216$ 9216.000 $\pm$ $9360$ 9360.000 $\pm$ $9504$ 9504.000 $\pm$ $9648$ 9648.000 $\pm$ $9792$ 9792.000 $\pm$ $9936$ 9936.000 $\pm$ $10080$ 10080.000 $\pm$	MATERIAL FINISH DO NOT SCALE DRAWING	SIZE <b>B</b>	CODE IDENT NO. <b>99-103</b>
NEXT ASSY APPLICATION USED ON	SCALE <b>1</b>	SHEET <b>2</b> OF <b>2</b>	<b>1</b>



1) USE TEFLON SLEEVING ON R2 AND R3  
NOTES: