

COMMERCIAL P. A. SYSTEMS

REFERENCE TEXT 58RX-1



NATIONAL RADIO INSTITUTE

WASHINGTON, D. C.

ESTABLISHED 1914

STUDY SCHEDULE

1. Introduction - - - - - Pages 1-6

Here you learn what information you should gather to plan an installation.

2. Indoor P. A. Installations - - - - - Pages 7-23

Low-power, medium-power, and high-power indoor installations are discussed here.

3. Outdoor P. A. Installations - - - - - Pages 23-28

Various problems involved in installing p. a. systems outdoors are discussed in this section.

4. Mobile P. A. Installations - - - - - Pages 29-36

This section contains a description of how to equip a sound truck for mobile p. a. service.



YOU have already studied the equipment used in public address systems. In this Lesson, you will learn how to put this equipment to work in typical indoor, outdoor, and mobile p.a. installations.

Commercial p.a. installations are not usually very complicated from the technical viewpoint. Mechanical problems met in mounting loudspeakers or in running cables may make some jobs rather difficult, but the electrical and acoustical theory involved is generally fairly simple and straightforward. We shall, therefore, concentrate mostly on the practical aspects of p.a. installations in this Lesson.

We shall also restrict ourselves to discussing installations that are bought by the customer, rather than rented, except in the case of mobile installations. The typical rented installation is rather simple. If you go into the business of renting p.a. systems, you will undoubtedly have a stock of conventional medium-power amplifiers, some portable loudspeakers, a few dynamic microphones, and one or two record players. You will use this same equipment for all jobs

as far as possible; obviously, you cannot afford to buy special equipment for one-time use. In other words, each job will be an adaptation of your existing equipment rather than an installation tailored for a particular problem. An installation that you sell, on the other hand, must meet the specific requirements of the location, and will therefore introduce problems in the selection and installation of equipment.

ADVANCE PLANNING

The simplest p.a. job, and perhaps the most common one, consists of making a temporary installation of a single microphone, a small amplifier, and one or two loudspeakers. These latter are usually housed in carrying cases that serve as baffles. Such an installation requires little or no advance planning if you are sure that a source of electrical power is available at the location to be used and that the equipment is adequate for the job. Any more complex installation, however, requires careful planning and preparation before the installation is made.

This planning consists of making a careful, detailed study of the location at which the installation is to be made and of reducing the results of your survey to written data that will show you exactly what is required to do the job. Naturally, the extensiveness of your study, and the completeness of your report, will depend on how complicated the installation is to be, but you should make an adequate study of every job except the simplest ones. Doing so makes it certain that you can set a price for the job that will be fair both to you and to your customer, and eliminates any chance of your running into unexpected difficulties.

Since proper advance planning is very important in a p.a. installation, let's spend a few moments now to learn just how you should go about making a job survey. There are three things to do:

1. Make a study of the location.
2. Make a sketch of the location, showing its shape, its important dimensions, and where the equipment is to go.
3. Put into writing other information gained from your study that will help you plan the installation.

To take care of this third step, it is a good idea to use a printed or mimeographed form that is complete enough to cover the most complicated job. Using such a form, rather than just taking notes, will keep you from forgetting to get some information that you will need.

A typical form is shown in Fig. 1. It is complete enough so that all the data required for a large, complex installation can be entered in it. On simpler installations, of course, you would not fill in the whole form—just the sections required for the particular job.

To show you the kind of informa-

tion you need to plan a commercial p.a. installation, let's discuss each of the headings on this job survey form one by one.

The need for the four items above the line on the form—the file number, the date, and the customer's name and address—is obvious.

The first heading under the line is "purpose of installation." State here briefly what the installation is to be used for, such as "music and voice in dance hall" or whatever it is. Be sure to learn whether the installation is to be used for voice alone, or for both voice and music.

Next, list the acoustical facts. If it is an indoor installation, make the proper entry beside the headings "Room Volume, cu. ft.," and "Number of Seats." Also, put check marks in the appropriate places to indicate whether the floor is hard, medium, or soft; whether the walls are hard, medium, or soft; and whether the ceiling is hard, medium, soft, flat, or curved. These acoustical qualities of a room were discussed in earlier Lessons, to which you should refer if you have forgotten what each of the terms means.

Next, determine what the noise level of the room is when it is being put to its intended use. If possible, visit the room while it is in use; otherwise, estimate what the noise level will be. Put a check mark on the form in the proper place to show whether the room is very noisy, noisy, medium, or quiet.

Next, under the heading "Remarks," make notes about any special conditions that may require unusual treatment. For example, if the room is made noisy by sound coming from a motor room or a kitchen, you may want to recommend the installation of a wooden partition or a special door

JOB SURVEY FORM

File No. _____ Date _____
 Customer's Name _____
 Address _____
 Purpose of Installation _____

ACOUSTICAL DATA

Room Volume, cu. ft. _____ No. of Seats _____
 Area, sq. ft. (outdoor only) _____
 Floor: Hard Medium Soft Walls: Hard Medium Soft
 Ceiling: Hard Medium Soft Flat Curved
 Noise Level: Very Noisy Noisy Medium Quiet
 Remarks _____

EQUIPMENT

No. of Loudspeakers _____ Make _____ Model _____
 Remarks _____
 No. of Microphones _____ Make _____ Model _____
 Remarks _____
 Radio Tuner Input Make _____ Power Supply _____
 Phono Input Turntables: 1 2 Make _____ Type _____
 Loudspeaker Wiring _____
 Microphone Wiring _____
 Power Wiring _____
 No. of Amplifiers _____ Make _____ Model _____ Power Output _____
 Output Impedance _____ Frequency Response: Hi-Fi Standard Special
 No. Microphone Inputs _____ No. Phono Inputs _____ Power Supply _____
 Remarks _____

COST ANALYSIS

Amplifier.....	_____
Loudspeakers.....	_____
Microphones.....	_____
Record Players...	_____
Radio Tuners.....	_____
Cables.....	_____
Labor.....	_____
Total	_____

Maintenance Agreement _____

Sound Engineer's Signature _____
 Customer's Signature _____
 Sworn To and Subscribed Before Me This _____ Day of _____
 Notary Public _____
 (My Commission Expires _____)

FIG. 1. This is a sample of the kind of job-survey form you should make up for use in planning p.a. installations. To economize on space, we have left out some of the blank lines that you would normally use in a sheet of this sort. For example, you would probably want to use two or three lines for "Remarks" in each instance, although we have left but one.

to cut down the noise. If there are marked reflection effects, you may want to install a drape or curtain on one or more walls or put sound-absorbing material on the wall, floor, or

ceiling. Make notes about any such conditions, because they will be important in your computations of the cost of the job.

If the installation is to be made in an outdoor location, enter the area in square feet in the proper place on the form. Determine the noise level at the location when a normal-sized audience is present, and check the form in the proper place to show whether the location is very noisy, noisy, medium, or quiet.

Next, under the heading "Remarks," make notes about any steady or intermittent sources of noise, such as nearby trains or heavy traffic, or anything else that will play a part in determining the equipment you should use for that location.

The information thus far recorded will let you compute how much power will be needed to supply an adequate volume of sound. This, of course, has an important bearing on the number and type of loudspeakers to be used and on the amplifier to be selected.

The rest of the form can be filled out either when you make the first inspection of the location or afterward, depending on how complicated the installation is going to be. If it is a simple one, you can specify such things as the locations of loudspeakers and microphones as soon as you have inspected the location; on more complicated jobs, you will want to do some figuring first. In either case, the next thing to be entered on the form is information about the loudspeakers. Enter first the number of loudspeakers, then the make and model of each. (You will probably specify the make and model only after you have done the rest of your figuring and are making up final specifications for the job.) Finally, enter any remarks you want to remember about special locations

and so forth. The actual placement of the speakers you should indicate on the sketch you draw of the location.

Similarly, enter the number of microphones, their makes and models, and any special remarks about them in the next section of the form. The use to which the installation is to be put will usually determine the number of microphones. Again, you will probably not specify makes and models until you are making your computations. The locations of the microphones should also be shown on your sketch of the installation.

If a radio tuner input is to be used with the installation, note that fact on the form by putting a check mark after the heading "radio tuner input." Enter the make of the tuner and the type of power supply required (separate or built-in).

Similarly, if a record player is to be installed, put a check mark on the form after the heading "phono input." Also check the form to show whether one or two turntables are to be installed and enter the make and type (single-play, changer, mixer-changer) in the spaces provided on the form.

Next, specify the details of the wiring that will be necessary to connect the various parts of the installation. Space is provided for loudspeaker wiring, microphone wiring, radio-tuner wiring, and power wiring. In each case, record the type, size, and length of wire needed. For example, if you are going to need twenty feet of No. 14 BX cable to a high-power loudspeaker and a light twisted pair to a small loudspeaker, record these facts by saying simply "20 feet No. 14BX to 25-watt driver," and "30 feet No. 18 lamp cord to single 5-inch p.m." Similarly, list the microphone, record player, radio tuner, and power wiring by type, size, and length of wire or

cable. (In many installations, of course, it will not be necessary to install special power wiring, since there will be outlets available into which the various pieces of equipment can be plugged.)

Information about the record-player wiring and radio-tuner wiring should all be concerned with the actual audio line from the equipment to the amplifier, not with any power wiring that may be necessary for them. This latter information should be listed under power wiring.

The general positions of all important wires should be shown on your location sketch. If there is apt to be any confusion because of the complexity of the installation, assign each circuit a number on your diagram and refer to the particular wire or cable by that number on your record sheet.

Once you have the facts concerning the speakers, microphones, and so forth, you will be able to select the type of amplifier needed. Space is provided on the form for you to show the number of amplifiers. If only one is to be used, list its make and model, its power output, its output impedance, the db gain of the microphone channels, the db gain of the phono channels, the number of microphone inputs, the number of phono inputs, whether or not a separate power supply is needed (you would fill this in as either "separate" or "built-in"), and the number of gain controls. There are also spaces that you can check to show whether the amplifier has a bass tone control, a treble tone control, or both, and to show whether the amplifier has a high-fidelity response, a standard frequency response, or a special response. (This last refers to an amplifier used for some special purpose requiring an extended low or high range of frequen-

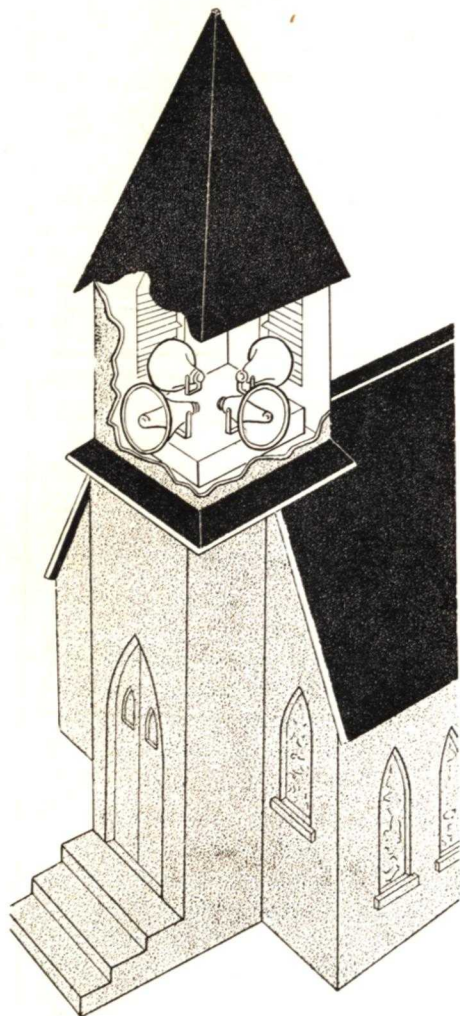

Courtesy University Loudspeakers, Inc.

This is a typical church installation in which reflex trumpets are used instead of bells in a steeple. Louvered openings (shown in the back walls of the steeple) permit the sound to escape. This system is popular because it is far cheaper to play recorded bell selections through an amplifier and project the music through the loudspeakers than it is to install a set of bells. A great many recordings of bell music are available for such use.

cies.) Finally, there is a space for you to enter any special remarks that you feel will be helpful.

If more than one amplifier is to be used, and they are all identical, this listing will serve for all. If two different amplifiers are used, list the data on one above that on the other, using the same blanks for both. In this latter case, be sure you are consistent about keeping the data on one amplifier on top.

This completes the information needed to plan the installation. In addition, of course, you need to make an accurate estimate of the cost of the installation for the customer. Space is provided on the form for this under the heading "COST ANALYSIS." Here, enter the list price of the amplifier, the loudspeaker system, the microphones, the record players, the radio tuner, and the cables. In addition, list the cost of the labor to the customer.

You may, if you wish, charge a flat fee for the labor involved in the installation. However, if the work is to be done partially or wholly by some one else—say by a licensed electrician, as is required in many communities—you'll probably not have any very good way of estimating just what the cost of labor will be. It is better, in

this case, to bill the labor as "time and material." This means that the customer is to pay for the material used and for the time actually spent in making the installation. The per-hour charge for labor should also be quoted; this figure should be high enough to cover the actual time charge of the workmen plus a reasonable profit for yourself. Be sure to remember this last item, because, on most jobs, the greater part of your profit will probably come from the labor charge.

In the space marked "Maintenance Agreement" write the details of any agreement you entered into with the customer about maintaining the equipment. For example, you might have an agreement to furnish one year's service at a cost to the customer of \$10 per call plus cost of replacement parts, or you might offer free service for 3 months and future service for an annual fee.

When you have completed filling out the form, make a copy for your customer, sign both copies yourself, and have him sign both copies also. If you feel it to be desirable, you can have both signatures notarized by a notary public; space for this is provided in the form.

Indoor P.A. Installations

Now that we've seen the general procedure to follow in making advance plans for any kind of installation, let's study in detail several typical installations—one of low power, one of medium power, and one of high power. We'll take up the low-power installation first.

LOW-POWER INDOOR SYSTEM

Let's suppose someone has asked you to install a small, low-power p.a. system for a large business luncheon

mercially available size, will provide enough power for the installation.

Amplifier. The Bogen E14 amplifier is well suited to this installation. Its schematic diagram is shown in Fig. 3.

This amplifier has two high-impedance microphone inputs and one phono input. Other models are available in which either or both of the microphone channels are low impedance. The amplifier delivers 14 watts at less than 5% distortion, and has a peak power of 25 watts.

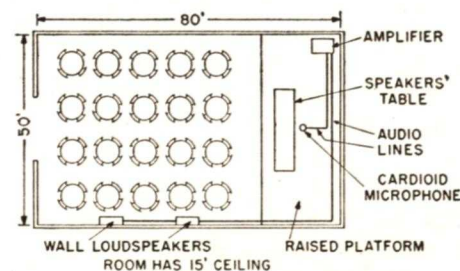

FIG. 2. This shows the sort of information you should put on a sketch of a proposed installation. You need not be as neat as this in your drawing, but be sure to take reasonable pains with it so that your finished sketch will be a recognizable plan of the installation.

where an audience of 100 people is expected.

The first step, as you know, is to inspect the location. Then you should make a sketch of the location and fill in the parts of the job survey form that apply to the particular job.

Let's suppose your sketch of the location is like that shown in Fig. 2. This sketch shows the general location of the mike, loudspeakers, and audience. As you can see, one microphone and two loudspeakers are to be used.

We'll assume that your studies of the location show that a power output of approximately 12 watts is needed to provide sound coverage of the room. A 14-watt amplifier, which is a com-

As you can see from the diagram, the microphone inputs feed into separate 7B4 voltage amplifier tubes, the outputs of which are fed to the grid of one section of a 7F7 dual triode. The output of this tube is fed to a voltage amplifier-phase inverter stage in which a 7N7 dual triode is used. The output of this last stage is fed to the control grids of the output stage, in which a pair of 6L6's in push-pull is used.

The phono input is applied to the grid of the other section of the 7F7 voltage amplifier, the plate of which is connected in parallel with the plate of the other section. All three inputs are therefore mixed before reaching

the control grid of the 7N7 voltage amplifier section. The volume level of each input is controlled earlier in the circuit by separate potentiometers.

A tone control circuit is incorporated in the grid circuit of the voltage amplifier section of the 7N7 stage.

The output of the amplifier is fed to two paralleled 5-hole speaker sockets. The output impedance of the amplifier at these sockets can be adjusted by connecting a flexible lead to any one of five terminals on a strip on the back of the amplifier. The available output impedances are 4 ohms, 8 ohms, 15 ohms, 250 ohms, and 500 ohms. A common (grounded) terminal is also provided on this strip so that you can, if you wish, connect speakers directly to the strip instead of to the speaker sockets.

Microphones. Either a crystal or a dynamic high-impedance microphone can be used with this amplifier. The microphone you choose should have a cardioid pickup pattern, since it is intended for use by someone speaking rather than for general sound pickup. The dynamic microphone is preferable in that it is more rugged than a crystal and less susceptible to damage if it is stored some place where the temperature becomes high. However, a good dynamic costs more than a good crystal microphone, so, if price is an object, it may be better to use the crystal type. A reasonably good crystal microphone will be perfectly adequate for the job it has to do in an installation of this sort.

Shielded lines must be used to connect the microphone or microphones to the amplifier. These should be not over 25 feet long, and preferably shorter. (If the microphone cable run must be longer than 25 feet, you should use a low-impedance microphone and the model of the amplifier

that has a low-impedance input.) Standard shielded lines are available that are automatically grounded when the plugs at their ends are connected to the amplifier.

Loudspeakers. Two 8-watt loudspeakers will provide sufficient sound coverage in a room of this size. These can be mounted in wall baffles that are secured to the side walls of the room. One should be near the front of the room and the other near the rear. It is probably best to mount them both on the same wall, although it will be well to experiment to see whether it might not be better to mount them on facing walls. They should not, of course, be directly across from one another.

Alternatively, you can use cone loudspeakers mounted in projectors. These are provided with mounting arms that can be secured to the wall. The projector can then be aimed in any desired position. If you use these projector loudspeakers, you should mount one on either side of the room slightly ahead of the speaker's table, aiming them so that their sound patterns cover the room completely.

It would be possible to use one loudspeaker instead of two as far as power requirements are concerned. In an indoor installation of this sort, however, it is better to use at least two loudspeakers to secure even sound distribution.

Whatever loudspeakers you use, make sure that they are placed so that their sound output does not reach the microphone. Otherwise, there will be a feedback of acoustical energy that can cause howling.

Installation. The installation of a system of this kind is not at all difficult. Essentially, all you have to do is connect the microphone and the speakers to the amplifier, and plug the

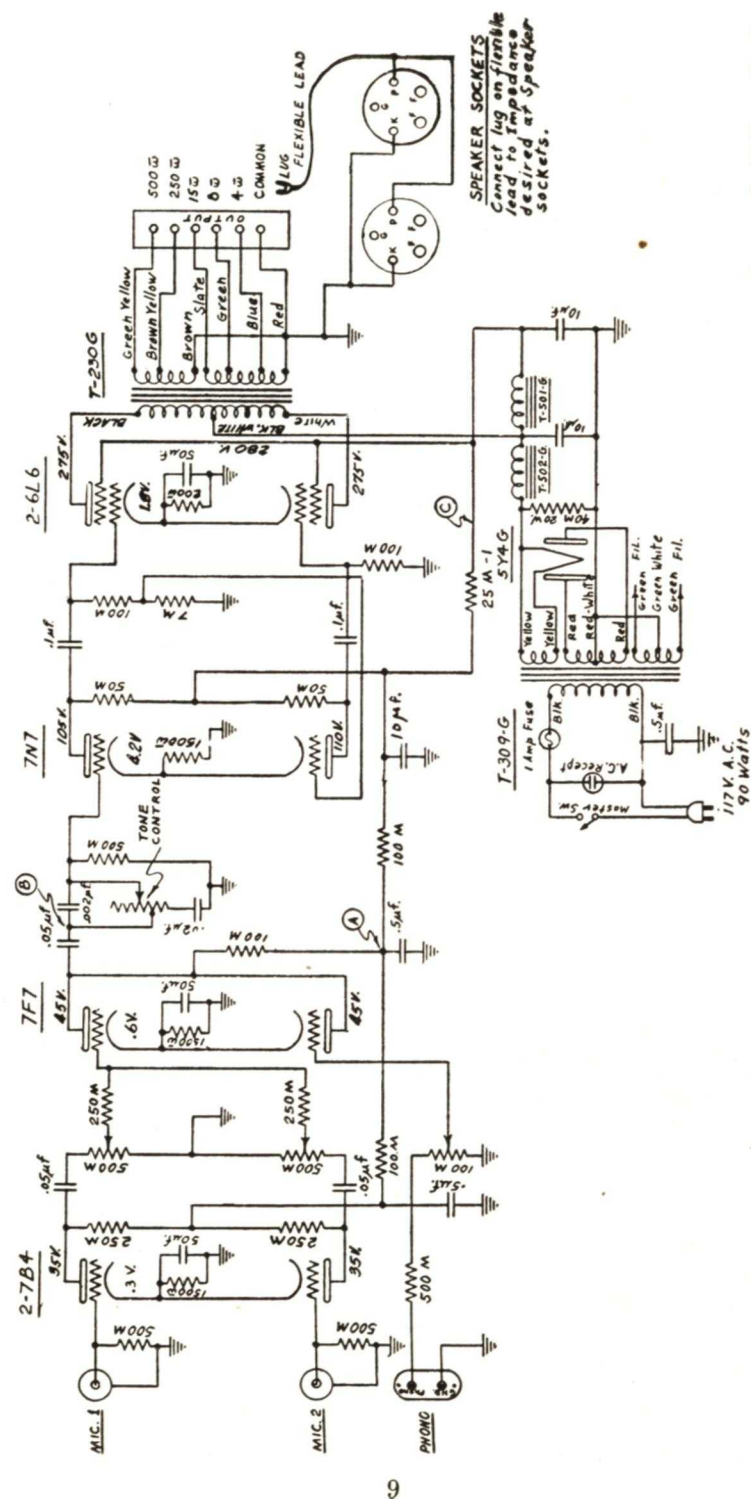

FIG. 3. Schematic diagram of a Bogen E14 amplifier.

Courtesy David Bogen Co., Inc.

amplifier into the power source. You will, of course, have to make a careful check of the system in operation to be sure that feedback and howling will not occur even when the amplifier is delivering maximum output. If you find it impossible to prevent some feedback at maximum output, you have to determine the maximum output at which howling will not occur;

announcement to speak louder than normal. When the luncheon is finished and scheduled speeches are being made, the noise level will be considerably lower and it will be desirable to reduce the amplifier output. Therefore, you should instruct the customer or one of his representatives in the manipulation of the volume and tone controls of the amplifier. If you have found it necessary to use less than maximum output to prevent acoustical feedback and howling, be sure to point that out to him.

In addition, teach the customer or his representative a few simple facts about the proper care and use of the equipment. If the microphone is to be stored when it is not in use, show him how to disconnect it and, if it is a crystal microphone, warn him about the effect of heat on the crystal. A little time spent in teaching someone how to use equipment properly may save you future complaints from the customer.

Now, let's see how you would go about installing a medium-power sound system.

MEDIUM-POWER INSTALLATION

The sketch of a typical medium-power p.a. installation is shown in Fig. 4. This installation is to be used to reproduce both voice and recorded music in an auditorium seating some 600 people. The reproducers are to be mounted on or near the stage. We'll assume that your preliminary acoustical studies have shown that a power of 25 watts will be needed.

A 25-watt amplifier like the Thordarson T-31W25A shown schematically in Fig. 5 will provide the necessary power. You can see from the schematic that this amplifier has two microphone inputs and one phono input. The amplifier is normally built with high-impedance microphone inputs, but

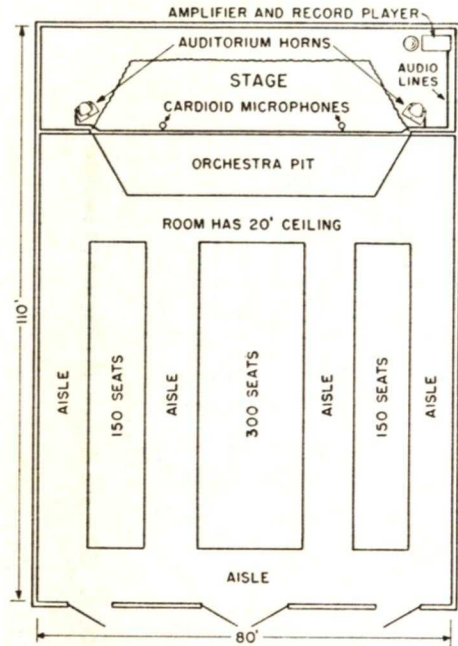
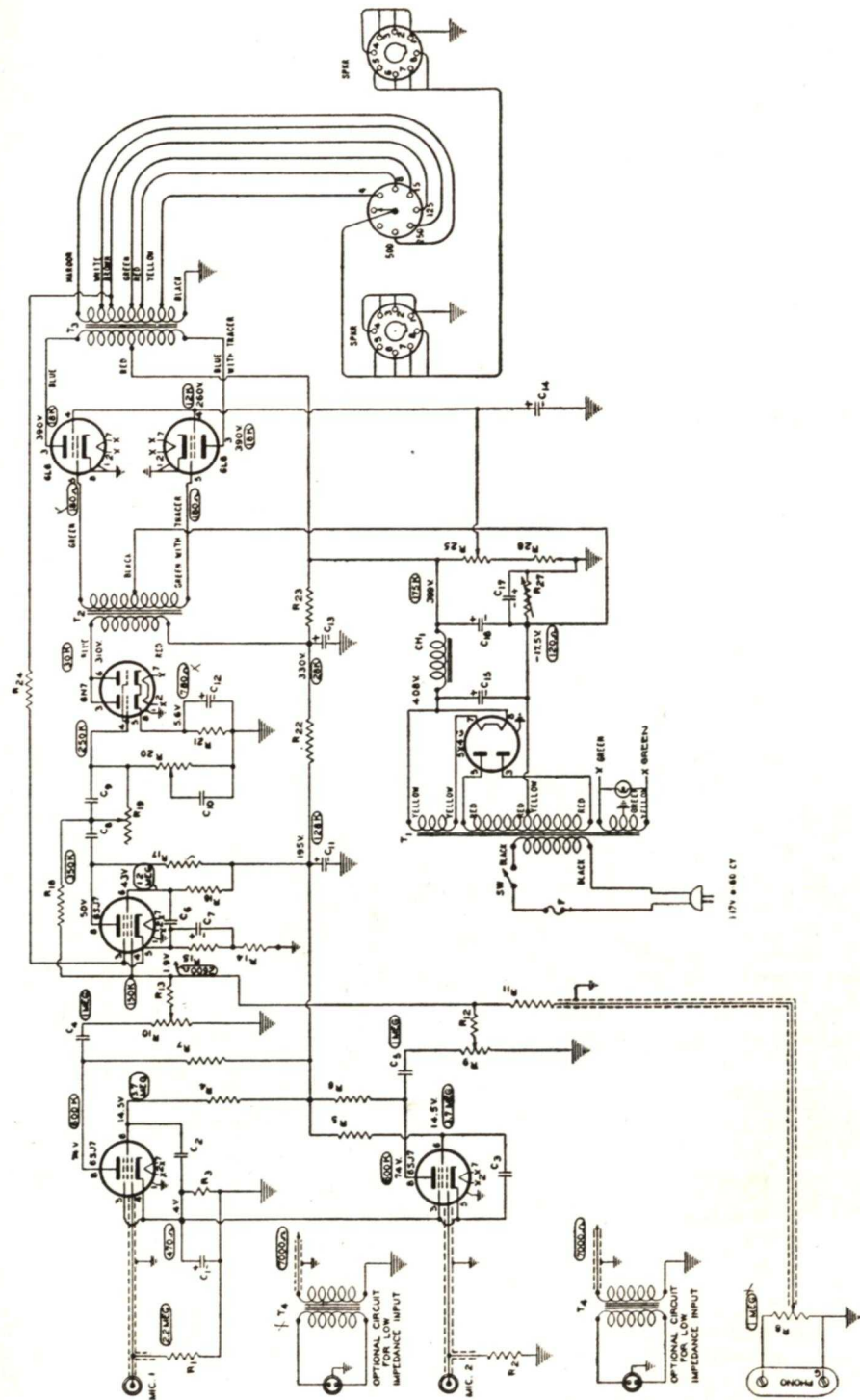

FIG. 4. Sketch of the auditorium installation discussed in the text. The part of the stage that is used for productions is enclosed by the wavy lines. As much as possible, audio equipment should be kept outside of this area.

this output level must then be considered to be the maximum usable output of the system.

A certain amount of monitoring is needed when an installation of this sort is in use. During a luncheon, the noise level in the room will be quite high. If announcements must be made during this time, it will probably be necessary to run the amplifier at full output and for the person making the



models with low-impedance inputs can be secured. Circuits for both types are shown in the diagram. The phono input is always high impedance.

Amplifier. Each microphone channel has a preamplifier stage in which a 6SJ7 is used. The outputs of both these stages and of the phono channel are applied to the grid of another 6SJ7 that is used as a voltage amplifier. The output of this stage is applied to a 6N7 driver stage that feeds the output stage, which contains two 6L6 tubes connected in push-pull. The 6N7 is a dual triode, but, in this use, its plates, grids, and cathodes are paralleled to double its power-handling capability.

The output transformer has a tapped secondary that offers output impedances of 4, 8, 15, 125, 250, and 500 ohms. A selector switch permits any of the taps to be connected to two paralleled sockets into which the speakers or the audio line is plugged.

Each channel contains a potentiometer by which the volume level of that channel is controlled. The amplifier has no master volume control with which the volume in all channels can be controlled simultaneously.

The frequency response of the amplifier is flattened by the use of inverse feedback in the 6SJ7 stage just ahead of the driver stage. There are two feedback paths, one from the secondary of the output transformer to the cathode circuit of the 6SJ7, and the other from the plate circuit of the 6SJ7 back to the grid.

The amplifier has a bass and a treble tone control. The bass control consists of C_9 and variable resistor R_{19} . Condenser C_9 is used in the coupling circuit between the 6SJ7 and the 6N7. Resistor R_{19} is shunted across it. The influence of C_9 on the frequencies passed to the 6N7 can be varied by varying the resistance of R_{19} . When R_{19} is adjusted so that

its resistance is maximum, the lower frequencies in the signal are dropped in C_9 ; when R_{19} is adjusted to have zero resistance, C_9 is effectively removed from the coupling circuit, and the low frequencies in the signal are passed on to the grid of the 6N7.

The treble tone control consists of potentiometer R_{20} and condenser C_{10} . The two ends of R_{20} are connected between the grid of the 6N7 and ground, and C_{10} is connected between the slider of R_{20} and ground. When the slider is run to the upper end of R_{20} , the higher frequencies are bypassed around the grid resistor, and

cycles. When these controls are in their normal positions, at which they provide no attenuation, the frequency response of the amplifier is flat within 1 db from 30 to 15,000 cycles.

Loudspeakers. Assuming that your figure of 25 watts is based on the use of high-efficiency loudspeakers, you must select either folded auditorium horns or reflex trumpets for this installation. Trumpets are not particularly suitable for use in auditoriums, particularly when music is to be reproduced. For one thing, they have a directional effect, and would therefore not provide even sound cov-



Courtesy Montgomery Ward

This is a typical temporary p.a. installation. Notice the amplifier beside the music stand at the extreme left. Cone loudspeakers mounted in projector housings are used. These housings, which have flared openings, give the loudspeaker output a certain amount of directional effect. Notice that the projectors are located ahead of or beside the microphones; this eliminates direct acoustical feedback and lessens the danger that the system will go into oscillation.

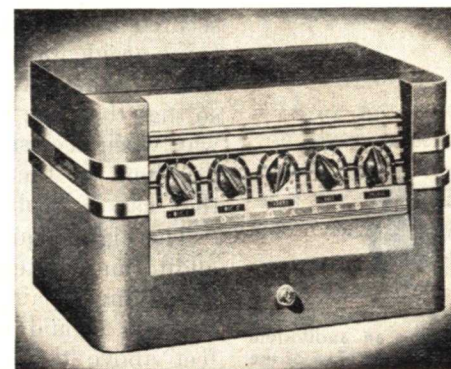

Courtesy Thordarson

The Thordarson T-31W25A 25-watt amplifier.

the high-frequency response of the amplifier is therefore reduced. When the slider is run down to the lower end of the potentiometer, the condenser C_{10} has no effect on the signal.

As you can see from this description, these tone controls are attenuators; that is, they can decrease the low-frequency or high-frequency response, but cannot boost it above the normal level. The bass control provides an attenuation of 20 db at 50 cycles and 12 db at 100 cycles. The treble control gives an attenuation of 40 db at 1000 cycles, 15 db at 5000 cycles, and 23 db at 10,000

erage of the auditorium unless they were very carefully aimed. Even more important is the fact that they have restricted low-frequency response, and are therefore not well suited to the reproduction of music.

The folded auditorium horn is superior to the trumpet in both respects. It offers wide-angle sound coverage and reproduces sound with much better fidelity. It has certain disadvantages, also: it is expensive, bulky, and heavy. There is, however, no better choice available where both high fidelity and high volume levels are needed.

High-power loudspeakers of the cone type mounted in console cabinets are sometimes used for sound reproduction in small auditoriums. Their fidelity, particularly when a tweeter-woofer combination is used, is very good, but they cannot handle volume levels as high as those handled by diaphragm-driven units, and their efficiency is considerably lower. In addition, such loudspeakers usually have considerable rear-end radiation, and they therefore produce acousti-

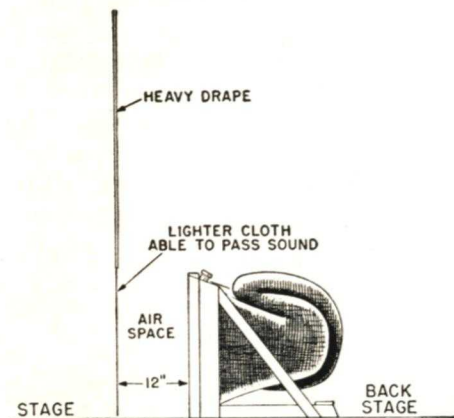

FIG. 6. Method of installing an auditorium horn so that it is concealed from the view of the audience but is not muffled.

cal feedback and howling unless they are very carefully placed with respect to the microphone. For this reason, they are usually not suitable for use in installations where the microphone may be moved about.

Let's assume, therefore, that you will install two folded auditorium horns.

It is usually impractical to mount these horns on the wall or suspend them from the ceiling; they are usually so big and heavy that mounting them in either of these ways would be a major construction job. Probably the easiest way to mount them is to install them on the stage, one at either end.

You will probably want to conceal the horns. To do so without interfering with their efficiency, hang a drape in front of them as shown in Fig. 6. Notice that this drape is made of two kinds of cloth: heavy material is used at the top of the drape to make it hang properly, and lighter material that will pass sound readily is used for the part of the drape that hangs directly in front of the horn. An air space of at least 12 inches must be left between the drape and the mouth of the horn to prevent an undesirable increase in the loudspeaker loading.

Preferably, the horns should be secured to the floor to prevent their being accidentally moved out of position. If they must be left unsecured so that they can be moved out of the way when necessary, mark the proper locations on the stage floor so that they can be replaced properly.

The high-frequency response of the auditorium system can be improved by adding a pair of tweeters. These tweeters should be placed 10 or 12 feet above the stage, one at either end, and tilted downward at about 20° from the horizontal. If tweeters are used, of course, a suitable high-frequency cross-over network must be used to supply high frequencies to the tweeters and low frequencies to the horns.

Microphones. As you know, the amplifier used with this installation has two microphone channels, each of which can be either high impedance or low impedance. It is not, of course, necessary to use both inputs; however, it is probably a good idea to do so if the stage is to be used for plays or for other activities that will require sound pickup over a wide area.

Since there may be an orchestra in the pit playing while the micro-

phones are in use, it is best to use microphones having cardioid pickup patterns. These microphones will then pick up chiefly the voices of those on the stage, more or less ignoring the sounds of the orchestra. Both dynamic and crystal microphones having cardioid pickup patterns are available.

There are several possible locations for the microphones. If they are to be used for picking up voices during the presentation of plays or other stage performances, you will probably want to conceal them as much as possible. One way to do so is to install them in the footlights. Of course, it may not be possible to use this installation if a trial shows that it does not give sufficient voice pickup, or picks up too much footnoise. In this case, it may be practical to suspend the microphones from the ceiling of the stage if doing so will provide better pickup. If the stage is deep, it may prove impossible to use concealed microphones and still get adequate pickup from all positions on the stage.

Amplifier Location. The amplifier may be conveniently located either back-stage or in the orchestra pit. If a phono pickup is to be used with the amplifying system, it will probably be best to place the amplifier and the phono attachment back-stage. Records can then be changed by the person operating the amplifier.

An installation of this sort will require a certain amount of monitoring, since it will probably be put to a variety of uses that will require changes in the volume levels and perhaps the tonal characteristics. Explain the operation of the various controls on the amplifier carefully and thoroughly to the person who will be in charge of it.

Tests. You should, of course, test

the operation of the system carefully after it is installed. In particular, make sure that there will be no feedback between the auditorium horns and the microphones. If a microphone is to be used on a stand, try it in all the positions in which it can be placed before concluding that there will be no feedback. If you find there is feedback, turn the auditorium horns slightly outward until it no longer occurs.

Now, let's see what procedure should be followed in installing a high-power indoor p.a. system.

HIGH-POWER INSTALLATION

The sketch of a large indoor installation is shown in Fig. 7. This installation is made in a large indoor arena. Its major use is for making announcements during sporting events, such as hockey games, prize fights, and basketball games, and for playing records before and after such events and during intermissions. Even though music is played over this system, intelligibility and carrying power are the chief requirements, not high fidelity. The fidelity should, of course, be as good as it is practical to make it without sacrificing power.

Let's assume your studies of the location show that adequate coverage will be given if an electrical power of 200 watts is used. This is to be divided among eight reflex loudspeaker trumpets, located in the center of the arena and each aimed at one of the sections of seats.

You can get the required electrical power using either a single high-power amplifier or a number of lower-power amplifiers. It is more common to use several amplifiers, since they are readily available, whereas single high-power amplifiers must usually be custom-built.

For example, 50-watt amplifiers are commonly available. Four of these amplifiers will supply a total of 200 watts, just enough for the installation. The schematic diagram of such an amplifier—the Thordarson T-31W50A—is shown in Fig. 8.

This amplifier has remarkably good fidelity for the power it handles. The manufacturer states that its frequency response is flat within 1 db from 30 to 13,000 cycles, and that there is less than 5% distortion at the full output of 50 watts. The 50 watts is a conservative rating; it will supply over 65 watts at peak power.

With two exceptions, which we shall discuss in a moment, the circuits of this amplifier are not unusual. There

are three high-impedance microphone input channels and one dual high-impedance phono input channel, all of which feed into a 6SJ7 voltage amplifier stage. Each of the microphone channels has one stage of amplification ahead of this common amplifier stage. The output of the 6SJ7 stage is applied to a 6J5 voltage amplifier, the output of which is applied to a 6V6 used as a driver for the output stage, which contains four 6L6's in parallel push-pull. The 6V6 used as a driver is triode-connected (the screen grid is connected directly to the plate). An input transformer is used to connect the driver stage to the output stage.

The output transformer is tapped

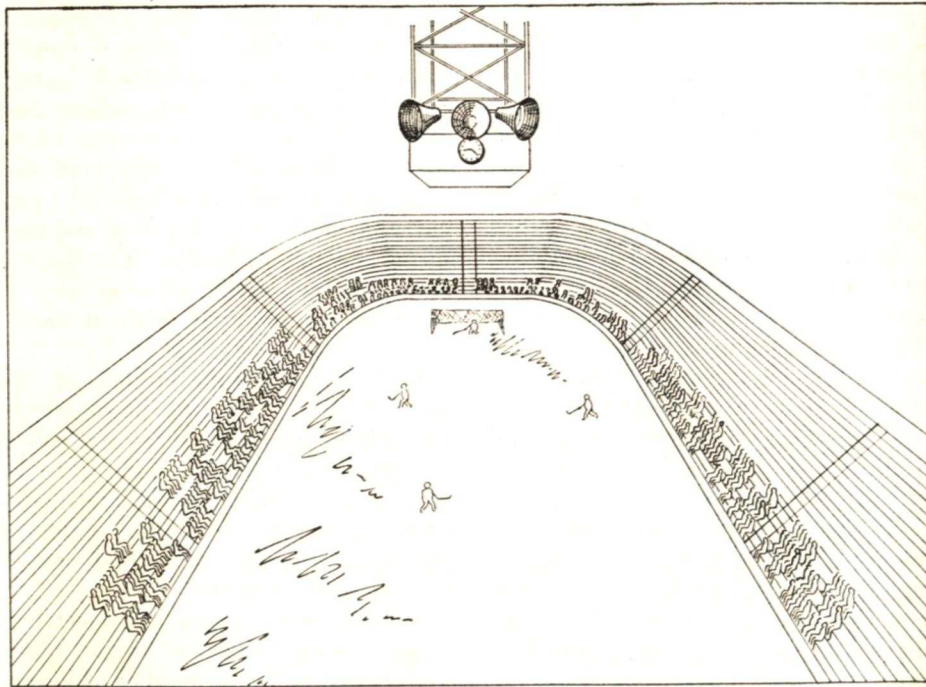
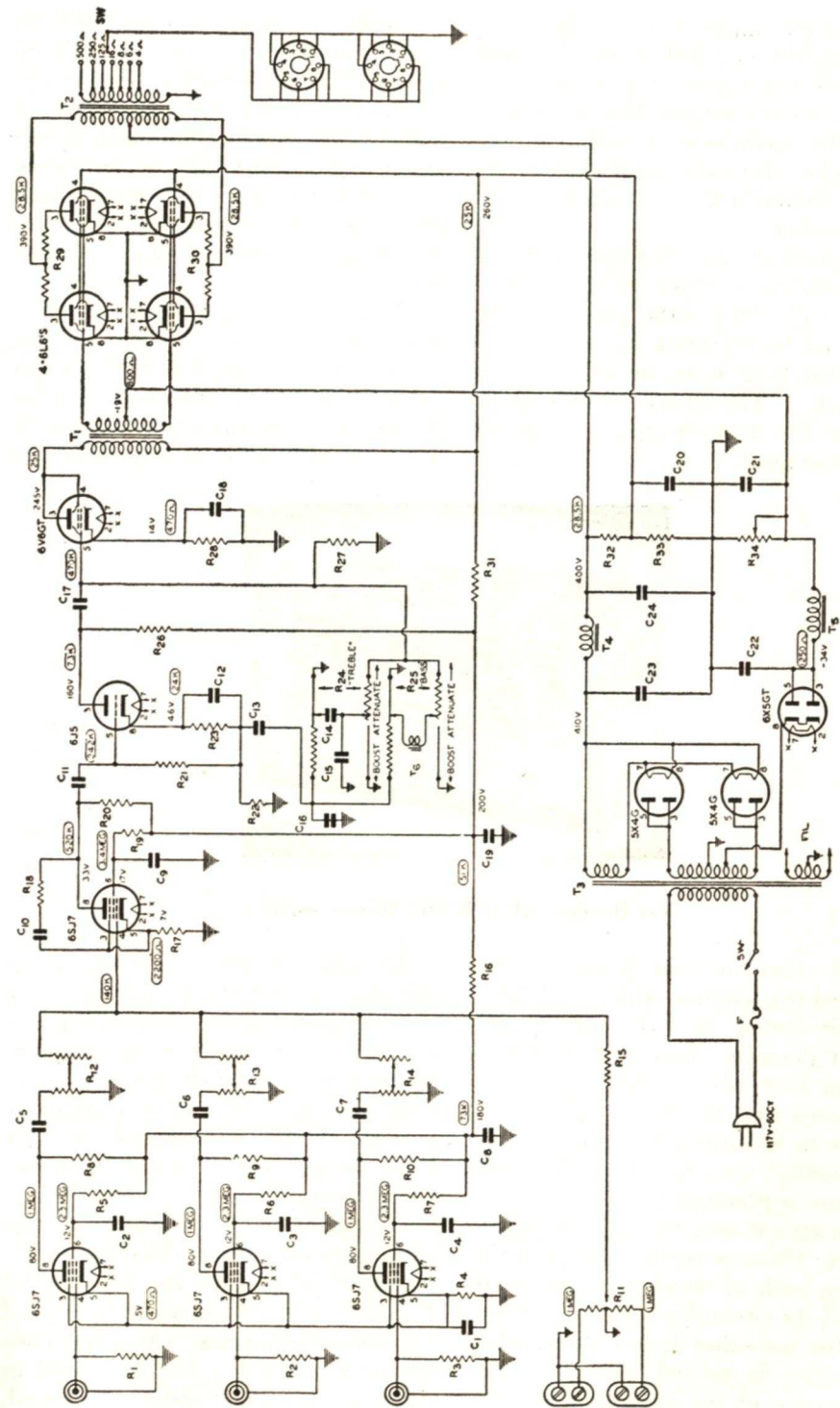

FIG. 7. This set-up is typical of those used in large indoor arenas. The loudspeakers are mounted on a platform suspended from the roof in the center of the area, a location that makes it possible to have a uniform sound coverage for all seats. Eight reflex loudspeakers, only 3 of which are shown in this sketch, are used to furnish the sound output. Each loudspeaker is aimed at the center of one section of seats. Notice that a clock is also mounted on the platform. In many installations, a clock and a scoreboard are mounted on each of the four faces of the platform for the convenience of the patrons.



Courtesy Thordarson
FIG. 8. Schematic diagram of the Thordarson T-31W50A 50-watt p.a. amplifier.

to provide impedances of 4, 6, 8, 16, 125, 250, and 500 ohms. A switch connects the desired tap on the secondary of the output transformer to half the receptacles in each of two parallel-connected octal sockets, from which connections are made to the loudspeakers.

We mentioned earlier that there are two unusual features in this amplifier circuit. One is the use of inverse feedback in the 6SJ7 voltage amplifier stage that is fed by all the input channels. The effect of this is to reduce the high-frequency response of the stage.

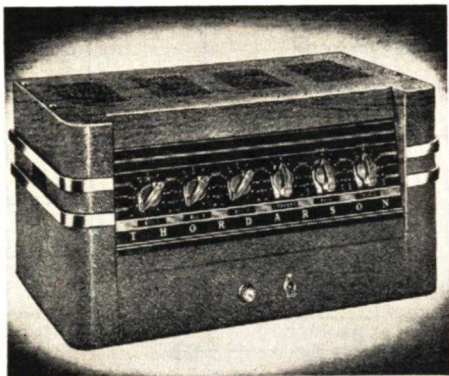

Courtesy Thordarson

The Thordarson T-31W50A 50-watt amplifier.

resistance between the slider and the end of the resistive element will increase until the slider has been turned to the center of the device; then the slider comes into contact with a section that has practically no resistance, and further rotation does not increase the resistance between the slider and the resistive end of the potentiometer.

To make up a dual potentiometer of the sort used here, two of these are mounted back to back so that a single control shaft operates both sliders. As you can see from the diagram in Fig. 8, with this arrangement the

The other unusual feature is the tone-control circuit, which is located directly below the 6J5 tube in the circuit diagram. This is a dual tone control that permits both the high-frequency and the low-frequency response to be adjusted above or below the normal position (at which the response is practically flat).

The circuit uses two dual potentiometers. These consist of two potentiometers, each of which is resistive for half of its circumference and conductive for the other half. Thus, when the slider is moved along the circumference of the potentiometer, the

slider arm of one potentiometer is moving over a resistive portion while the other is moving over a conductive portion; then, when the midpoint of the control is reached, the slider of the first changes over to the conductive portion of the first control and the slider of the second starts on its resistive portion.

Degeneration is produced in the cathode circuit of the 6J5 stage of this amplifier because of the presence of R_{22} , which is inadequately by-passed for audio frequencies. (Although condenser C_{13} and C_{16} are connected in series across this resistor to ground,

their net capacities are so small— C_{16} is only .001 mfd.—that the series combination has little by-passing effect even at fairly high audio frequencies.) Since this resistor is in the cathode circuit, the tube plate current must pass through it; therefore, a voltage is developed across it that is in phase with the a.c. signal current of the tube plate current.

By tracing through the circuit carefully, you can see that the voltage developed across the load of the preceding 6SJ7 stage, which is the source of the signal applied to the grid of the 6J5, is in series with the a.c. voltage developed across R_{22} . Therefore, the algebraic sum of these a.c. voltages is applied to R_{21} as the grid signal. These two voltages are always opposite in polarity at any instant, so the voltage applied to the grid of the 6J5 stage is always the difference between them.

For example, when the a.c. voltage across R_{20} is such that the upper or plate end of the resistor is positive, the voltage applied to R_{21} will make the grid of the 6J5 more positive. This will cause an increase in plate current, causing a voltage drop across R_{22} having a polarity such that the cathode end of R_{22} will be positive. Trace the circuit—you will see that the voltage across R_{22} will then oppose the voltage across R_{20} (remember, we are talking about a.c. signal voltages). Therefore, the voltage applied to R_{21} will be less than it would be if R_{22} were not present. In other words, the presence of R_{22} tends to reduce the grid signal, with the result that for a given input signal, the amplification of the 6J5 stage is less than it would be if R_{22} were not in the circuit. This effect, as you have learned in earlier Lessons, is called degeneration.

Since this is a resistance network, its effect is the same for all frequencies in the audio range. The tone control is designed so that it can reduce the amount of degeneration caused by R_{22} for certain frequencies. Of course, if the amount of degeneration is reduced for any given frequency, the amplification of the 6J5 stages increases as far as that frequency is concerned. This amounts to a boost for this particular frequency.

First, let's see how the treble boost control operates. As you can see from the diagram, condenser C_{14} is connected between the two sliders of this control. As the sliders are rotated from the center position of the control toward the "boost" end, a network consisting of C_{14} plus part of the resistance of the potentiometer is connected in parallel with condenser C_{16} . As the control is advanced toward the boost end, the resistance in this network is decreased; when the control reaches the full boost position, all resistance is removed and C_{14} is in parallel with C_{16} . Resistor R_{22} is always by-passed by the series combination of C_{13} and C_{16} , but the capacities of these two are so small, as we said earlier, R_{22} is effectively by-passed only for the highest audio frequencies. However, when the treble tone control is advanced to the boost position and C_{14} is put in parallel with C_{16} , the capacity of the by-pass network is increased to such an extent that practically all the high frequencies pass through the condensers rather than through R_{22} . As a result, there is little degeneration as far as these frequencies are concerned, and the high-frequency output of the amplifier is effectively boosted as a result.

The bass boost tone control works in much the same way, except that

a coil T_6 is connected between the two sliders. When this control is at the full boost position, the by-pass path around R_{22} consists of C_{13} and T_6 . Since T_6 has a high impedance for high frequencies, and a low impedance for low frequencies, this path is effective as a by-pass for the lows. Thus, advancing the bass tone control to the full boost position reduces the degeneration in R_{22} for the lows and effectively boosts the low-frequency response.

The boosts offered by these controls are not extremely great. The bass control gives a bass boost of $9\frac{1}{2}$ db at 80 cycles, the treble control gives a boost of $11\frac{1}{2}$ db at 8000 cycles.

These controls provide attenuation of the treble or bass in a similar manner by providing a variable by-pass for R_{27} , the grid resistor of the 6V6 stage. At the full-attenuation position of the treble control, condensers C_{14} and C_{15} are connected to ground in parallel across R_{27} . The high frequencies are then shunted to ground across this grid resistor, thus reducing the high-frequency part of the signal applied to the grid of the 6V6. When the bass control is advanced to its full-attenuation position, T_6 is connected to ground in parallel with R_{27} . Coil T_6 then acts as a low-impedance shunt for the low frequencies, reducing the proportion of them in the signal applied to the grid of the 6V6 and thus reducing the low-frequency output of the amplifier.

The attenuations offered by the controls are somewhat greater than the boosts they provide. The bass control gives an attenuation of 25 db at 80 cycles, and the treble control gives an attenuation of 25 db at 8000 cycles.

Amplifier Location. Usually the best place to locate the amplifier is the

announcing booth. Then the announcer or technician can monitor the system when it is necessary to do so. The record player used with the system should also be located in the announcing booth so that the records can be changed by the announcer or technician in charge of the assembly. If there is no announcing booth in the arena, the amplifier should be located in some convenient place at which it can be monitored readily.

Loudspeakers. Eight 25-watt reflex trumpets will provide adequate sound coverage in this arena. You can see from the sketch that they are mounted on a platform suspended from the center of the roof. This arrangement, which is frequently used in indoor arenas, has the advantages that it permits each loudspeaker to cover a large area and also that all listeners are about the same distance away from the loudspeakers. This latter is an advantage because it permits the volume level to be about the same at all seats.

It is common practice, when this platform arrangement is used, to make the platform very substantial and to suspend scoreboards, lights, and perhaps a timing clock from it, as well as to use it as a mounting point for the loudspeakers. Such a platform must, of course, be installed by a construction crew; it is not part of the duties of the p.a. expert to build it or supervise its building.

A typical reflex trumpet suitable for use in this application has a sound dispersion angle of 90° and a low-frequency cut-off of 120 cycles. The fidelity of reproduction will not be too good with a cut-off characteristic of this sort, but it will be good enough for the uses to which the amplifier system is to be put. If the

arena is to be used for public ice skating, it may be desired to play records of organ music over the p.a. system; in this case, a somewhat larger reflex trumpet capable of reproducing lower frequencies should be installed.

A reflex trumpet is usually equipped with a mounting bracket that makes mounting it on a platform of this sort very simple. Just secure the bracket to the platform near the edge with screws, and the mounting job is done. Before mounting each loudspeaker, be sure to position its brackets so that you can aim the loudspeaker at approximately the center of the section of seats it is to cover.

Power Distribution. Since all eight loudspeakers are to be installed in

approximately the same location, the most practical way to feed them is to connect them so that they form a common load for all four amplifiers. The chief problem involved in doing so is to connect these lines in such a manner that their net impedance will be a value that can be matched to the amplifiers with an available transformer.

A sketch of the connections in the distribution system is shown in Fig. 9. As you can see from the sketch, each loudspeaker is connected to the secondary of a matching transformer (T_1 through T_8), the primaries of which are connected in parallel to a single line. The four amplifiers, also connected in parallel, are connected to the other end of the line.

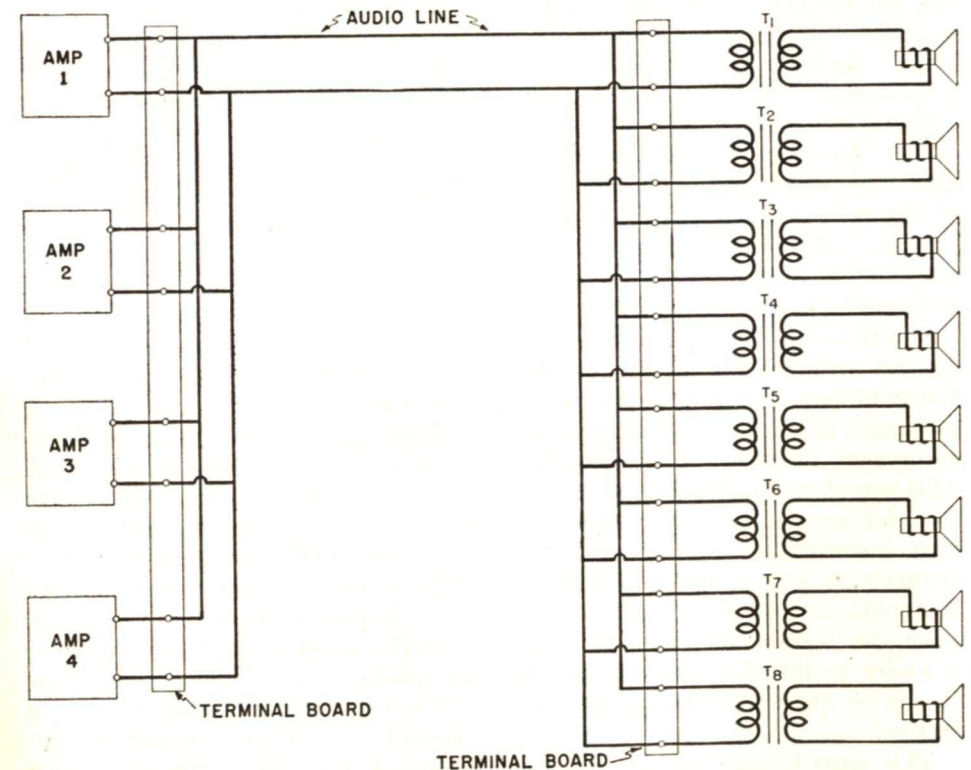

FIG. 9. Power distribution system used to feed 8 loudspeakers from the outputs of 4 amplifiers. The 8 matching transformers, T_1 through T_8 , are used to make the net impedance of the paralleled amplifiers. Notice that all connections are made to terminal boards for neatness and convenience.

Of course, the distribution system must provide proper impedance matches to prevent waste of power. In the system shown in Fig. 9, matching transformers T_1 through T_8 must provide primary impedances of 1000 ohms each when they are connected to the loudspeakers. The net primary impedance of all the transformers when they are connected in parallel will then be 125 ohms ($1000 \div 8$). At the other end of the system, the 500-ohm output terminals of the four amplifiers must be connected in parallel. The net output impedance of the four amplifiers is then also 125 ohms ($500 \div 4$). The paralleled speakers can then be connected to the paralleled amplifiers by an ordinary twisted-pair line. In theory, this line should also be 125 ohms in impedance, but, as a practical matter, standard p.a. cable, which has an impedance of approximately 500 ohms, can be used without there being any serious mismatch. To avoid excessive power loss due to resistance in the line, the wires in the cable should be 14 gauge.

Notice that the primaries of the matching transformers are brought to a terminal board before the parallel connections to the line are made. A similar arrangement is also used at the amplifiers. In each case, the terminal board should be very close to the equipment to which it is connected. This use of terminal boards is a good idea for several reasons: it makes a neat installation, it is of great assistance in helping you to identify individual circuits when you are servicing the installation, and it makes it easier to install a new component if one of those in use becomes defective.

This distribution system has two particularly good features. One is that it makes it unnecessary to use

line-matching transformers; the only transformers used in the system are the impedance-matching transformers used at the loudspeakers, which would be necessary in any distribution system. The other advantage of this method of wiring is that only one line is run from the platform where the loudspeakers are mounted to the place where the amplifiers are installed. This, of course, represents a great saving in wire over what would be needed if individual lines were run from the loudspeakers to the amplifiers.

Microphones. Normally, only two microphone inputs and one phono input are used in an installation of this sort. One microphone is located at some point from which the announcer can see the floor area of the arena clearly. If the arena is used for boxing or wrestling, it is usual to have a microphone arranged so that it can be lowered to a point just above the ring for the making of announcements and can be taken out of the way during the progress of the bout. Sometimes provision is made for a third microphone that is located near the edge of the floor so that an official, such as the scorekeeper at a basketball game, can make announcements.

There are so many possible variations in the microphone set-up in an arena of this sort that we cannot give any definite rules for it. It is probably best, under almost any circumstances, to use microphones having cardioid pick-up patterns, since each microphone will usually be intended for use by only one person at a time.

You may find it necessary to use a pre-amplifier with one or more microphones if the microphone cable must run a long way to the amplifier. It is unlikely that the microphone cable

will be so long that the input signal will be too attenuated to operate the amplifier. However, it may well be that there will be enough hum pick-up in the microphone cable to cause trouble unless pre-amplification is used. The hum signal will not be harmful, of course, if the microphone output is built up to such an extent by a pre-amplifier that its level is much greater than that of the hum picked up. The only way to tell whether or not hum is going to be bothersome is to run the microphone cable in its proper location and make an operating test. If hum is then objectionably noticeable, you should consider using a pre-amplifier.

If a pre-amplifier must be used on a microphone that is to be lowered over a boxing or wrestling ring, probably the best place for you to locate it is on the platform where the speakers are mounted. Some care may be necessary in choosing the proper location for the pre-amplifier in this case, because some of the sources of hum, such as timing clocks, may also be located on the platform. Naturally, pre-amplification must occur before the hum signal is picked up by the microphone cable; otherwise it will be amplified along with the microphone signal, and the pre-amplification will be of no value. If the pre-amplifier is located on the platform, you will probably have to arrange some method of turning it on and off

remotely unless the platform is so situated that it is easy to get to it.

If you find that a pre-amplifier is necessary for use with a microphone that is to be used on a judge's or scorekeeper's table on the edge of the arena floor, you will probably find it best to install the pre-amplifier on or under the table. It will then be possible to change the volume level of the pre-amplifier easily whenever it is found to be necessary. However, in most uses, and particularly when the pre-amplifier is to be located some place that is hard to reach, it is best to leave the volume level fixed and adjust the overall volume of the system at the main amplifiers.

If a microphone is to be lowered from the ceiling or from the platform to a ring, it will be necessary to provide a mechanical means for doing so. The simplest method is to suspend the microphone from a heavy cord, such as a sash cord, and run the cord through a guided pulley or two to some location from which an attendant can raise or lower the microphone as desired. A more elaborate method is to secure the cord to a small drum driven by a reversible electric motor; the microphone can then be raised or lowered by operating a switch by means of which the motor can be turned off or made to run in either direction. It is not advisable to suspend the microphone by the microphone cable alone.

Outdoor P.A. Installations

There are two chief differences between outdoor and indoor p.a. installations. One is that area, not volume, is the factor that you must consider in determining how much power is going to be needed to provide adequate sound coverage outdoors. The other is that the loudspeakers you use and the lines through which they are fed must be weather-proof.

speaker outdoors. A steel mast is frequently used for this purpose.

One method of installing such a mast is shown in Fig. 10. This mast is a heavy steel pipe, at least 3 inches in diameter, imbedded in concrete. The distance that the end of the pipe is below the ground should be at least one-third of the total height of the pipe above ground.

A mast of this sort may be used

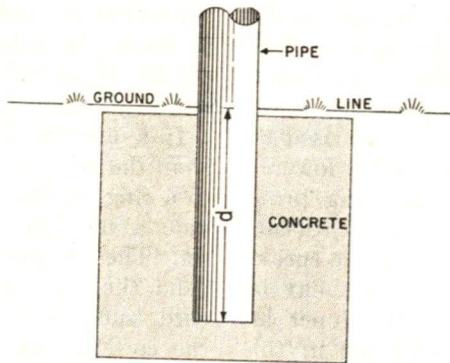

FIG. 10. A strong, permanent outdoor loudspeaker mast can be made by imbedding a pipe in concrete. The distance "d" should be at least one-third of the height above ground of the mast.

In its other essentials, however, an outdoor p.a. installation is like an indoor one. Similar amplifiers are used for both applications, although greater power is usually needed outdoors. Therefore, we shall not discuss the theory of the outdoor installation very much, since it does not differ basically from what you have already learned. Instead, we shall take up specific points that you would meet in outdoor work but are not likely to meet in indoor installations.

MOUNTING LOUDSPEAKERS

Very often, some support must be constructed for mounting a loud-

to support either a single loudspeaker or a cluster of them. The loudspeakers may be permanently secured to the top of the mast if desired; however, it will then be necessary for a serviceman to get to the top of the mast if one of the loudspeakers becomes defective. In many installations, the problem is solved by mounting the loudspeakers on a sliding collar that fits around the mast and raising or lowering the whole assembly with the aid of a rope that is secured to the collar, run over a pulley at the top of the mast, and brought down to a cleat at the bottom of the mast. This rope can then be used to raise

the loudspeakers to the top of the mast for use and to lower them to the ground for servicing.

If this method is used, the loudspeaker cables should be brought down through the hollow interior of the mast to a hole drilled near the bottom. The cables can then be fed into or pulled out of this hole as the loudspeakers are raised or lowered.

If the loudspeakers are to be fastened permanently to the top of the mast, the cables should again be let down through the inside of the mast and brought out through a hole in the side of the mast near the bottom. They should then be secured to terminals in a junction box, which should then be secured to the mast over the hole.

Even thick-walled steel pipes in a 3-inch or 4-inch size may not be strong enough to hold up three or four heavy loudspeakers if the mast is tall. The strength of the mast can be very considerably increased by pouring it full of concrete after it has been set in place. Of course, if you do this, you will be unable to run the cables from the loudspeakers down through the pipe. If you prefer to have the cables hidden when the installation is complete, run a piece of conduit through the pipe from the top to a hole near the base before you pour the concrete into the pipe. Be careful not to pour any concrete into the open end of the conduit. Then, when the concrete is set, you can thread the loudspeaker cable through the conduit and still have a reinforced mast. Alternatively, you can fill the mast solid with concrete and run the loudspeaker cables down the mast on the outside, enclosing them in heavy conduit.

Whether the loudspeaker cables are brought down the inside or the out-

side of the mast, they should go underground very near the base of the mast. In fact, it may be desirable to have them come down underground at the base of the mast. We will discuss this matter of underground cables in more detail a little later in this Lesson.

Under some conditions, it may be desirable to use semi-permanent masts instead of permanent ones. This may be true, for example, when a football field is to be used during the summer months as an outdoor auditorium. In this case, masts will be needed for a period of several weeks, but cannot be left in place indefinitely.

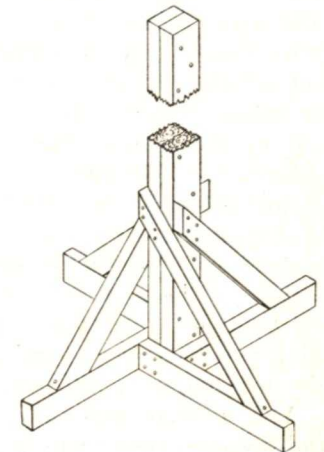

FIG. 11. This shows one way to build a sturdy wooden mast for temporary outdoor installations. Be sure to use 2 x 4 timbers. A height of 12 or 14 feet is about the maximum that is practical.

A sketch of a temporary mast capable of supporting heavy loudspeakers is shown in Fig. 11. This mast is supported by heavy wooden braces at its base rather than by being sunk into the ground. Under ordinary conditions, such a mast may be self-supporting, but, to insure stability in high winds, wire guys should be used to steady it. These guys should

be brought to stakes permanently imbedded in the ground.

In installations such as football stadiums in which the seats rise in tiers from the ground, the loudspeakers are sometimes placed at ground level and aimed up at the seats. This is not perhaps the best system from an acoustical viewpoint, since the distance of the loudspeaker from the seat varies for each seat. However, it is one way of furnishing sound coverage without having the loudspeakers interfere with the view of the spectators.

In such an installation, the loudspeaker should be on some form of platform. A concrete block of suitable size, with one or two screws set into it to form a mounting point, is excellent for the purpose. The loudspeaker cable should be brought directly from the loudspeaker to the ground through a conduit.

If an installation is to be made in a field having covered stands, the loudspeakers can usually be secured to the roof of the stands or to the supports holding up the roof. There is nothing particularly unusual about such an installation in the technical sense. You must be sure, of course, that the speakers used will provide adequate coverage for all seats. In this as in all other outdoor installations, the loudspeaker cables should be run through conduit, both to protect them from the weather and to keep them from being cut by vandals.

All the mounting methods we have described so far are chiefly used when a considerable number of loudspeakers are to be used. Actually, for most purposes, it is better to use very few loudspeakers and concentrate them at one point if it is possible to do so. This procedure will minimize the echo effect that a listener gets from

hearing the sound from two or more loudspeakers that are located at differing distances from him. Some sound engineers feel that the use of a great many loudspeakers enhances the brilliance of music, but, in the average installation, the problems created by the use of many loudspeakers more than outweigh the benefits gained by using them.

In a large outdoor installation, the use of only a few loudspeakers means that they must be very high-power units. A few types of loudspeakers of extremely high power are available; one kind, used on top of the Empire State building in New York, transmits the sound of a carillon for distances up to fifteen miles. Such a loudspeaker, which has a continuous operating capacity of 300 watts, is too powerful for any except a very large installation. However, there are smaller versions of this loudspeaker that can be used with less power.

Two or three such loudspeakers of suitable power, mounted on top of the center-field wall, can provide adequate sound coverage in a baseball field. One of the chief objections to the use of extremely high-power units is that the listeners near the loudspeakers must be subjected to an uncomfortably loud sound if distant listeners are to hear at all. However, in baseball parks, in particular, it is often possible to find a mounting place for the loudspeakers that no listeners will be very near; if this can be done, then it is perfectly practical to use very few loudspeakers of very high power.

DISTRIBUTION LINES

The audio lines used to feed loudspeakers and outdoor installations must be protected from the weather. Many owners of outdoor installations

have also found it necessary to protect the lines from people who maliciously or thoughtlessly cut them if they are left exposed. Cutting a cable seems to be a pointless form of destruction, but it does occur unless precautions are taken to prevent it.

Both problems can be solved by installing the cables in conduit. This conduit may or may not be buried in the ground, depending on the location of the loudspeakers. If a loudspeaker is on a mast that is standing by itself some distance from the amplifier, obviously the conduit running from it to the amplifier should be buried in the ground. If, however, the loudspeaker is mounted on the roof support of a grandstand, the conduit may be run down from the loudspeaker and underneath the grandstand to the amplifier location. In this latter case, there is no need to bury the conduit in the ground.

Rubber and lead-covered cables should be used for all outdoor audio lines. This cable, when it is enclosed in conduit, is very nearly proof against all forms of corrosion. It cannot readily be spliced, however, without introducing the possibility of corrosion at the joint. Unless you have had experience in running conduit and in using this rubber and lead-covered cable, you should have it installed by an electrician. In fact, the laws of many communities require that such work be done by a licensed electrician.

Cables that must run in the open should be buried 6 to 8 inches under the surface of the ground. You should draw an accurate map showing the locations of any buried cables so that they can be readily located in case one of them becomes defective. If possible, make sure that you do not bury a cable in any location that is

apt to be dug up at any future time.

The most permanent form of wiring now available consists of rubber and lead-covered cable in a special gas-tight conduit that, after the installation is completed, is pumped full of nitrogen under about 80 pounds pressure. The presence of the gas prevents condensation from forming in the conduit, thus helping to preserve the cable.

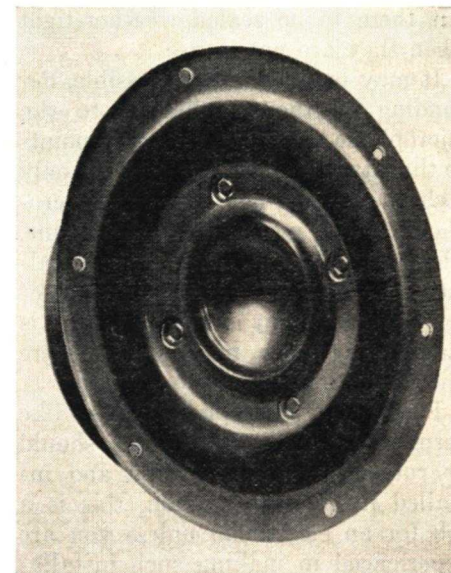

Courtesy University Loudspeakers, Inc.

The University Model MM-2 loudspeaker, a submergence-proof unit intended primarily for marine use. It is also well suited for applications involving extremely dusty conditions, since its method of construction prevents any foreign material from entering the mechanism. The loudspeaker has a flanged rim for mounting in bulkheads or walls. It drains automatically in the operating position.

Such an installation is, of course, expensive, and must be performed by a trained man; however, if an extremely long-lived installation is wanted, it may be worth while to go to the expense of using gas-filled conduit.

MICROPHONES

Microphones are never permanently installed out of doors. There may be,

and commonly is, one installed in the announcing booth if there is such a booth at the site of the installation, but microphones are much too delicate instruments to be exposed permanently to the weather. Therefore, in a permanent installation, you will run microphone lines to the places where microphones will be used and terminate the lines with a connector. These connectors have screw caps that permit them to be sealed weather-tight when they are not in use.

It may or may not be possible, depending on the installation, to run microphone lines to a number of points so that it will be necessary to use only a short coupling line from any microphone to the nearest permanent line. This can usually be done if the installation is in an outdoor auditorium or some other similar location where it is possible to know in advance where microphones are going to be used.

Permanent microphone lines, like permanent loudspeaker cables, should be rubber and lead-covered and installed in conduit. Again, this is a job for an electrician unless you are experienced in making such installations.

Generally speaking, dynamic microphones are best for outdoor work. They are both more rugged and more weatherproof than other kinds. It is possible to use other microphones when special requirements make it necessary; for instance, velocity mi-

crophones might be used when the best possible fidelity is wanted. As a general thing, however, it is best to plan on using dynamic microphones.

In setting up the microphones lines, you must be careful to use the microphone input of the amplifier that corresponds to the impedance of the microphones that will normally be used. Most dynamic microphones have output impedances of 200 to 250 ohms; if dynamics are to be used, then, the permanent microphone lines should be connected to the 250-ohm inputs of the amplifier. Of course, high-impedance microphones, such as crystal microphones, should not be connected to the permanent microphone lines unless the other ends of the lines are transferred to the high-impedance inputs of the amplifier.

Microphone lines should always be shielded to minimize hum and noise pick-up. It is not necessary to use shielded cable in the permanent microphone lines as long as you ground the conduit in which the lines run. It is inadvisable to run two unshielded lines in the same conduit, however, since there may be energy interchanges between them. The connecting line between the microphone and the permanent line should be shielded and should be grounded at the point where it connects to the permanent line. Usually the plug used to make the connection will complete the ground connection to the shield.

Mobile P.A. Installation

If you become a p.a. expert, very likely you will find it profitable to have a sound truck. Let's see how you can equip a truck for use as a portable p.a. system.

The first question to settle is the kind of truck you are going to use. Most sound trucks are of the light or medium-duty panel delivery class. If you own a shop and already have a delivery truck, very likely you can convert it for use as a sound truck and still have enough room in it for deliveries too. It would be perfectly possible to use a station wagon; in fact, it would be desirable to do so, since it would be possible to ventilate the inside of the vehicle far more easily than it is when a panel truck is used.

Next is the problem of selecting the equipment to use. The fact that the equipment is to be mobile, and therefore cannot be operated from a power line, means it must be economical of power. This means that we must choose an efficient amplifier and use efficient loudspeakers. Assuming that you will not want to use a motor generator set for providing power, you must choose an amplifier that can be operated from a vibrator power supply powered by a storage battery. In most installations, the truck battery is used as a power source, although, of course, it is always possible to use a separate storage battery—perhaps installing an extra generator on the truck engine to charge it.

Since you will probably want to have sound coverage in all directions from the truck most of the time, you will want to use four loudspeakers, one mounted at each corner of the

truck roof. Reflex trumpets are the most practical form of loudspeakers to use, both because they are highly efficient and because they are weather proof.

The rest of the equipment you will need to complete the sound truck installation is a microphone, a record player, and possibly a radio tuner. These are standard items, no different for mobile installation than for any other. Many mobile amplifiers are available that have record players already installed in their tops.

Now, let's discuss the equipment and its installation in more detail.

Amplifier. The Airline 30-watt mobile amplifier is typical of those used in sound trucks. A schematic diagram is shown in Fig. 12. Notice that its power supply can operate from either a regular a.c. power line or from a 6-volt storage battery.

Aside from its power supply, this amplifier is conventional. It has two high-impedance microphone channels and two high-impedance phono channels. Each microphone channel feeds into a 6SQ7 voltage amplifier stage. The signals from these two stages are fed through individual volume controls, one for each channel, to a master volume control. Both signals are fed through this master control to the rest of the amplifier.

A potentiometer having a grounded center point is connected across the two phono input channels. As a result, a signal applied to one of the phono channels appears across half the potentiometer, and a signal applied to the other channel appears across the other half. Since there is only one slider on the potentiometer, the signal from only one phono chan-

nel can be fed to the amplifier at one time. As you rotate the slider from one end of the potentiometer to the other, the level of the signal from one phono channel will be reduced from full volume to zero; then, as rotation continues, the level of the signal from the other phono input will rise from zero to full volume. This arrangement permits smooth control of the input from the two phono channels.



Courtesy Thordarson
The 20-watt Thordarson T-31W20A-X mobile amplifier. It can be used on either 110-volt a.c. or 6-volt d.c.

The phono input signal, like the microphone input signals, is applied to the master volume control. Thus, if signals are fed in simultaneously from 2 or 3 channels, the master control can raise or lower the level of all the signals by the same amount, but cannot change the level of one signal with respect to that of another. Changes in the relative levels of the signals are controlled by the volume controls in the individual channels.

After passing through the master volume control, the signals are applied to a 6SQ7 voltage amplifier stage. Succeeding stages in the amplifier consist of another 6SQ7 voltage amplifier stage, a 6F6G driver stage, and an output stage containing two 807's in push-pull.

A feature of this amplifier is the manner in which various output impedances are made available. As you can see from the diagram, the impedance of the complete secondary of the output transformer is 500 ohms. Taps make it possible to have 8 ohms, 4 ohms, 2.7 ohms, or 2 ohms impedance. These taps on the secondary are brought out to a 5-position speaker selector switch that can be rotated to furnish the desired impedance at

the output terminals of the amplifier. At the 500-ohm position of the switch, the ends of the secondary are connected to a terminal board mounted on the rear of the amplifier. Other positions of the switch, marked 1, 2, 3, and 4 on a dial plate, connect the taps on the secondary to paralleled receptacles that are also mounted on the rear of the amplifier.

These receptacles are used when loudspeakers having 8-ohm voice coils are to be connected to the amplifier. When one such loudspeaker is to be used, leads from its voice coil should be plugged into one of these receptacles, and the speaker selector switch should be turned to position 1, thus connecting the 8-ohm tap to the receptacles. If two loudspeakers are to

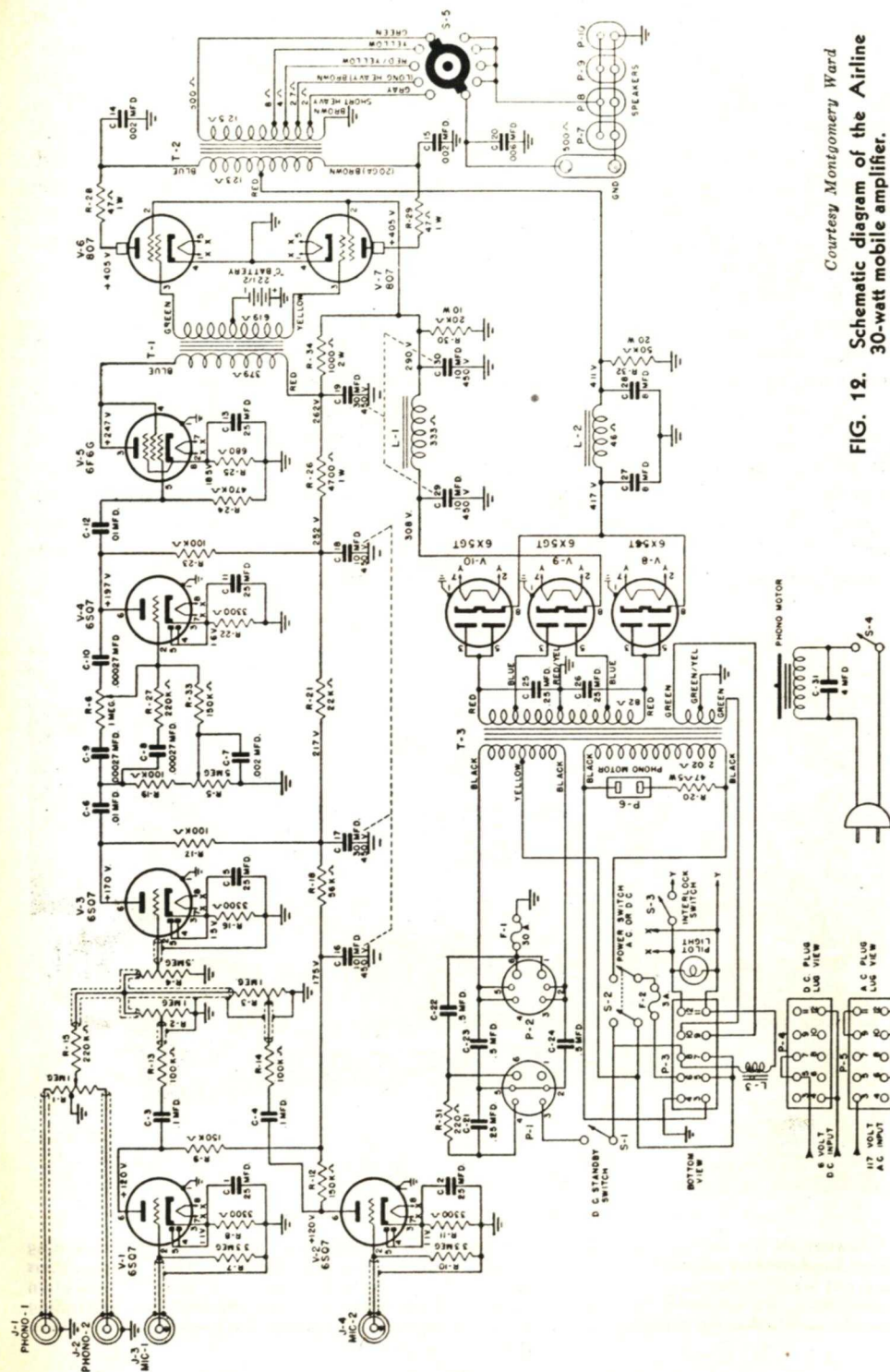

Courtesy Montgomery Ward
FIG. 12. Schematic diagram of the Airline 30-watt mobile amplifier.

be used, each should be plugged into a receptacle and the switch set to position 2, thus connecting the 4-ohm tap to the receptacles. Similarly, if three loudspeakers are to be connected, the switch should be turned to position 3, connecting the 2.7-ohm tap to the receptacles; and, with four loudspeakers plugged in, the switch should be turned to position 4, connecting the 2-ohm tap to the receptacles.

Of course, this system can be used only with loudspeakers having 8-ohm voice coils, and then only when they are to be not more than 75 feet from the amplifier. If loudspeakers having other impedances are to be used, or if they are to be some distance away from the amplifier, the 500-ohm impedance of the amplifier should be

selected by turning the selector switch to the position marked "500 Ohm." Then the loudspeakers should be connected to the 500-ohm terminal on the back of the amplifier, using suitable matching transformers. In sound-truck use, where the lines are very short, it is quite practical to use the loudspeaker receptacles with 8-ohm loudspeakers.

Incidentally, notice that this selector switch does not permit loudspeakers to be cut in and out of the circuit. Turning the switch to any position furnishes a particular output impedance to all the receptacles, but does not cut off the power supplied to any of them. If you wish to cut out one loudspeaker, you must unplug it from the amplifier and change the setting of the selector switch to

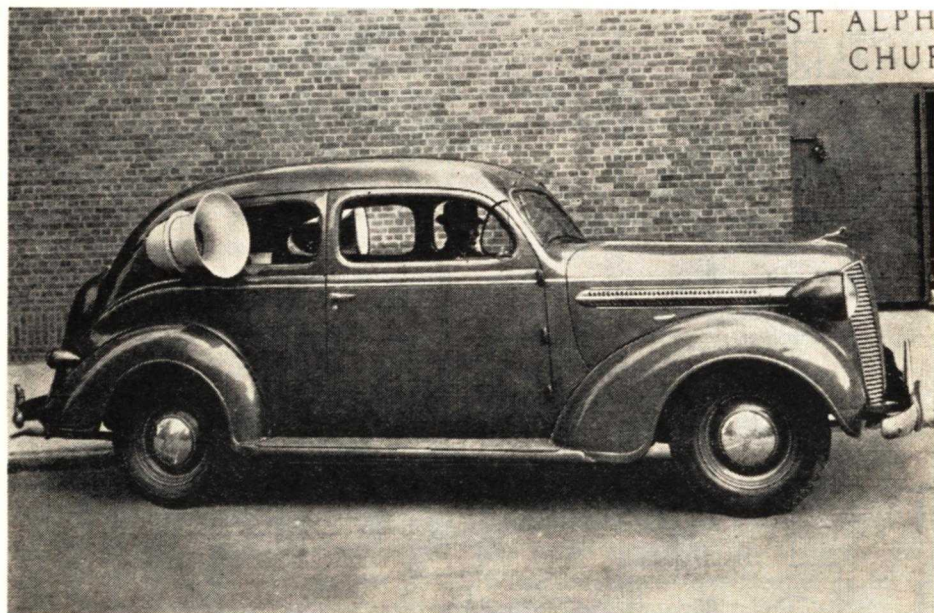

Courtesy Wholesale Radio Service Co., Inc.

A passenger car can be temporarily converted to a sound truck, as this was, by mounting cone loudspeakers encased in projector housings in the rear window openings. These loudspeakers are not weather proof, so they are not suitable for permanent outdoor use, but they are often satisfactory on a temporary basis. The amplifier can be in either the rear or the front seat, depending mostly on whether the driver or a passenger is to operate it. For safety, it is preferable not to have the driver do so.



Courtesy Maryland Amplifier Co.

This commercial sound truck is unusually well equipped with loudspeakers. The six loudspeakers mounted at the sides of the truck, three on either side, are used on most jobs. The large loudspeakers mounted fore and aft are used when extreme power is wanted.

the next lower number. If such a change is to be made, be sure the amplifier is turned off when you unplug the loudspeaker; otherwise the output stage might be damaged.

The amplifier is equipped with a standby switch for use when the amplifier is operated from a storage battery. Throwing this switch to the OFF position applies power to the filaments of the tubes, but cuts it off from the vibrator. The amplifier is then in the standby condition; when the standby switch is snapped to the ON position, power is applied to the vibrator and the amplifier is ready to operate. This arrangement permits the amplifier to be ready for instant use without drawing much power when it is not in use.

When this amplifier is operating from batteries, it draws 30 amperes. Therefore, it is a good idea to use two storage batteries to operate it to be sure of having plenty of reserve

power. It would also be wise to install an extra generator on the truck engine to take care of charging these batteries.

This amplifier is supplied in two models. One is equipped with a 2-blade record changer installed in the top panel, the other has a single-play record player similarly located.

Loudspeakers. As we said earlier, reflex trumpets are the logical choice for use with a sound truck. Some sound trucks are equipped with only 2 loudspeakers—one pointing dead ahead and the other directly back. Since reflex trumpets have sound dispersion angles of only about 90° at most, arranging loudspeakers in this fashion will mean that no sound is projected to either side of the truck. If you want the sound to be audible on all sides of the truck, and, in most cases, you probably will, it is better to use 4 loudspeakers and mount them on the corners of the roof.

The loudspeakers may be mounted directly on the roof of the truck with machine screws passing through the mounting brackets. If you prefer not to cut holes in the truck roof, you can get a rubber-footed mounting platform resembling the luggage racks and ski racks that are used on passenger cars. These are held to the roof by suction cups and by mounting straps that hook under the rain ledge or window edge. If you mount the loudspeakers directly on the roof, make sure that the mounting holes are near some strong part of the roof, such as a roof bow. If you mount them in a part of the roof that is remote from supporting members, their weight may be enough to distort the roof metal when the truck starts or stops. Be sure to weatherproof the holes with sealing compound after the loudspeakers are installed.

If possible, the loudspeakers should be mounted so that they do not extend beyond the sides of the truck. This means that a loudspeaker mounted at one corner actually has its mounting point near the center of the truck, since reflex trumpets range from sixteen inches to twenty-nine inches in length.

Some sound truck owners find it desirable to have one trumpet pointing straight ahead. This lets the truck project a strong signal straight forward, thus attracting attention to the fact that it is coming. You may wish to do this yourself.

Reflex loudspeakers are usually equipped with 25-watt driver units. If we drive four of these units with a 30-watt amplifier, the individual loudspeakers will be supplied with only $7\frac{1}{2}$ watts apiece. This, of course, decreases the amount of sound that can be projected in any given direction, although it does provide uni-

form sound coverage in all directions. If you wish, you can use only 2 trumpets, feeding them with 15 watts each. The loudspeakers will then project the sound further, but, since you are using only two, you can cover only about 180° around the truck compared to the 360° you can cover using 4 loudspeakers. Of course, you can get both increased distance and complete angular coverage by using a more powerful amplifier. Your choice will depend mostly on what you expect to use the sound truck for. If its chief use is to be cruising the streets making announcements, it is probably best to use the 4 speakers and have the complete 360° coverage.

Installation. Fig. 13 shows one way you could arrange the inside of the truck to accommodate the equipment. The shelves shown are deep in the truck, right against the back of the driver's compartment. These shelves should be heavy wooden planks about 2 feet wide. They should be covered with heavy felt or rubber to dampen mechanical vibration. This is a convenient arrangement, but not the only possible one; you can use any arrangement you feel is best for you.

Be careful to get the wiring from the amplifier to the loudspeakers out of the way as much as possible. Run it directly up to the roof, then over to the loudspeakers—don't let it hang free in the space inside the truck, because it may get ripped loose accidentally. Be sure to waterproof the holes through which the loudspeaker cables are led inside the truck.

Remember that the inside of a closed truck can get extremely hot if the truck has been in the sun for a while. For the comfort of the operator of the equipment, and to protect the equipment from excessive heat, you must provide some means

of ventilating the truck interior if it has no windows. An electric fan or air scoops cut in the sides of the truck may be needed. Remember that any form of air intake or air circulator (such as a fan) must not create any noise within the truck, since such noise might be picked up by the microphone.

HIGH-POWER MOBILE INSTALLATION

The equipment we have just described is what is used in the usual sound truck. It is entirely adequate for a truck that is going to be used mostly to cruise streets making announcements, but it does not have the

power to be heard for long distances nor to be used in addressing a large group of people.

Some sound trucks that are used for such purposes are in existence. These have a great deal more power—200 or 300 watts, in some cases—and they cannot, of course, be operated from a regular storage battery. When powers of this sort are required, it is necessary to use some form of motor-generator set as a power supply.

Often these high-power installations are made in a trailer, rather than in a truck. One reason for doing so is that these high-power mobile units are sometimes used in one lo-

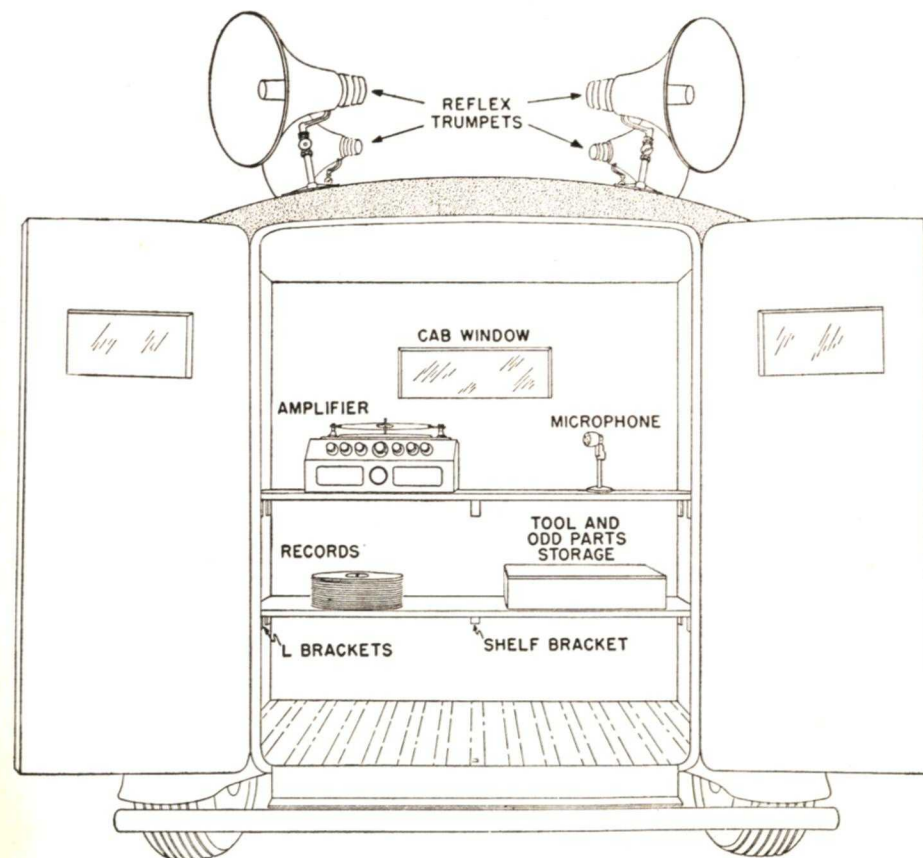

FIG. 13. Suggested arrangement of equipment in a sound truck. Placing the equipment against the back of the cab in this manner uses up only about two feet of the depth of the truck body, so it will still be possible to use the truck for making deliveries.

cation for days or even weeks at a time, acting as temporary p.a. installations rather than truly mobile equipment. Such high power is seldom necessary for street-cruising work.

When several hundred watts of power are available, a variety of loudspeaker arrangements are possible. There is even one installation in which the entire front of a trailer has been converted to form a huge exponential horn. In other installations, portable loudspeakers are used that are set up on temporary masts around the truck or trailer when it is parked

at the place of its use. Such mobile systems are also sometimes provided with two sets of loudspeakers, one for use when high power and great coverage is desired, and the other, of medium power, for use when intense sound is not needed.

We shall not attempt to describe a typical high-power installation, because there are too few of them for any to be considered typical. The facts that you have learned about any high-power installation will help to guide you in designing such equipment if you should want to.



THE BUSINESSMAN KNOWS

Here is another quotation which is a favorite of mine. I believe you will agree that it contains much good, sound advice.

“Business is a game of skill, which every man cannot play, which few men play well. The right businessman is one who has the just average of faculties we call commonsense; a man of strong affinity for facts, who makes up his decision on what he has seen. He is thoroughly persuaded of the truths of arithmetic. There is always a reason, in the man, for his good or bad fortune; and so, in making money. Some men talk as if there were some magic about this, and they believe in magic, in all parts of life. The businessman knows that all goes on the old road, pound for pound, cent for cent—for every effect there is a perfect cause—and that good luck is another name for tenacity of purpose.”

Ralph Waldo Emerson wrote this many years ago. But the points he makes are just as true today as they were the day they were written.

J.E. Smith