

**INTRODUCTION TO  
PUBLIC ADDRESS**

REFERENCE TEXT 52RX



**NATIONAL RADIO INSTITUTE**

**WASHINGTON, D. C.**

**ESTABLISHED 1914**

## STUDY SCHEDULE

For each study step, read the assigned pages first at your usual speed, then reread slowly one or more times. Finish with one quick reading to fix the important facts firmly in your mind. Study each other step in this same way.

- 1. Introduction . . . . . Pages 1-6  
This section contains a brief discussion of the requirements and problems of public address systems.
- 2. The Decibel and Power Ratios . . . . . Pages 6-9  
The uses of decibel units in p.a. work are discussed in this section.
- 3. Amplifier Specifications . . . . . Pages 10-15  
Here the meanings of the various specifications given in manufacturers' amplifier catalogs are discussed.
- 4. Power Supplies, Output Stages, and Drivers . . . . . Pages 15-25  
The general characteristics of these stages in p.a. equipment are described in this section.
- 5. Voltage Amplifier Considerations . . . . . Pages 25-31  
This section contains general descriptions of the various kinds of input couplings, mixing arrangements, and tone-control networks used in p.a. amplifiers.
- 6. Typical P. A. Diagrams . . . . . Pages 32-36  
The schematic diagrams of two typical amplifiers are discussed in this section.

COPYRIGHT 1949 BY NATIONAL RADIO INSTITUTE, WASHINGTON, D. C.

NPC5M250

1950 Edition

Printed in U. S. A.

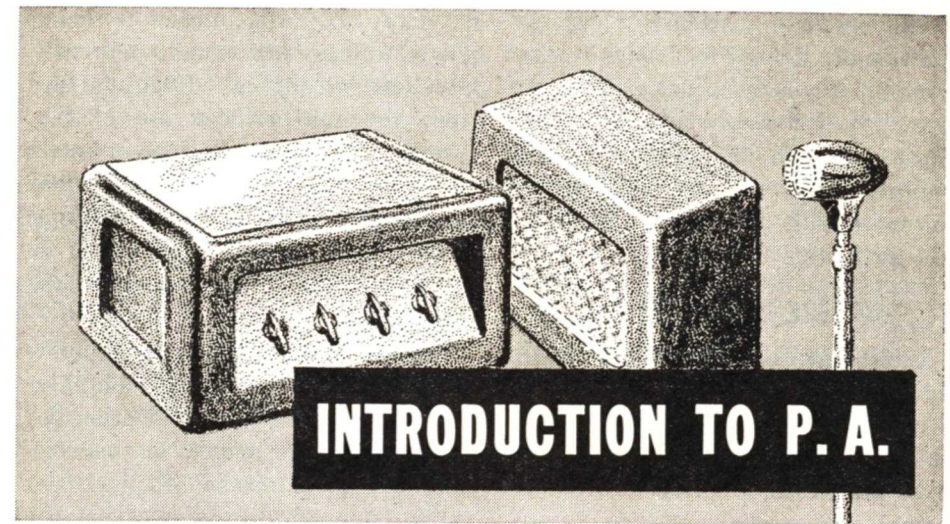

**R**ADIO servicemen constantly have opportunities to take on profitable side lines. Of course, a man who has so much radio service work that he does not have the time to do anything else may be uninterested in any of these extra sources of income. However, radio servicing is a seasonal business—there is much more repair work at certain times of the year than others, and a means of keeping up the income during the dull season is desirable. Also, to the man who is not overloaded with service work, because of competition or the smallness of his community, these side lines represent a means of augmenting the regular service income.

As you might expect, these side lines usually involve electrical apparatus or electronic equipment in one form or another. For example, it is quite common to find that the local radio serviceman also repairs home appliances, such as irons, toasters, and lamps. In an industrial community, he may work on a certain amount of electronic control equipment.

A profitable and logical side line

is public address. It is a logical field because it uses loudspeakers and other devices with which you are already familiar. Servicing such equipment is just as profitable as servicing radios is; furthermore you can make additional profits by installing and selling equipment if you wish.

A lack of information about public address equipment prevents many servicemen from taking advantage of this field. Also, in many localities the opportunities appear to be limited. However, in most cases, this lack of opportunity is entirely a result of the fact that no one has taken the time and made the effort needed to create a demand for public address equipment, because there have been too few men trained to recognize the usefulness of the equipment, to recommend the proper installation, and to install it. The wide-awake serviceman can increase his opportunities by seeing to it that more use is made of this equipment.

Whether future opportunities cause you to enter the field only part way—

to the extent of servicing or perhaps occasionally doing installation work—or whether you eventually decide to specialize exclusively in public address, you will find these Lessons helpful. They will present the important details you need to know to succeed in this field.

## WHERE IS P.A. USED?

Public address (commonly abbreviated “p.a.”) equipment is known to most people only as a system used where large numbers of people are to be addressed. As examples of occasional or seasonal uses, p.a. equipment is being used more and more at circuses and carnivals, political conventions or rallies, and at special events such as county and state fairs, rodeos, etc. There are other places, such as airports, railroad and bus terminals, etc., in which year-round use is made of sound-amplification equipment.

In addition to these applications, in which the sound systems are primarily used for amplifying speeches or giving information, there is an increasing use of p.a. systems in the entertainment field. Sporting events require systems for making announcements. Lecturers and speakers at dinner meetings also use sound systems to amplify their voices. Dance music in ball-rooms is now commonly fed through p.a. systems; in addition, such systems are frequently used for amplifying the music of soloists or even full orchestras at concerts.

Moving from the field of gatherings brought together for specific entertainments or functions, we find that sound systems are beginning to be widely used to provide entertainment

in many factories—music is being played for the workers and apparently increases production. Even further from the conventional use of p.a. systems are the installations in hotels and hospitals in which individual speakers in rooms are used to bring entertainment to the hotel guests or to the hospital patients more or less individually.

Similar to these are intercommunicators, which are basically amplifier units designed for communication between just two people or between small groups of people. Typical uses are for interoffice communication between an executive and his secretary or his department heads, for communication from a service desk to a service department in a store, and for communication from lunch counter to cook in a restaurant, to mention just a few.

As this list shows you, there are a great many possible uses for p.a. equipment, and therefore there are a great many p.a. systems already in existence. All of these systems have to be serviced from time to time. Furthermore, many new systems are being installed all the time as new uses for p.a. equipment are developed. There is, therefore, an increasing opportunity for the serviceman in p.a. work.

## P.A. REQUIREMENTS

Now that you’ve seen what some of the uses of p.a. systems are, let’s see what requirements the equipment must meet in these applications.

The basic p.a. system is shown in Fig. 1. It consists, as you can see, of an input device (in this case, a microphone), an audio amplifier, and a

loudspeaker. All p.a. systems contain these elements. Many systems are more complex than this, having extra input devices (other microphones, record players, and occasionally radio tuners) and multiple loudspeakers, but basically they are all alike.

When such a system is used for addressing a large crowd, the chief requirement made of it is that it must have enough power to make it possible for everyone to hear. If music is to be played over the system, it must have at least a reasonably good fidelity of response in addition to sufficient power. If the music is intended for a critical audience, the fidelity of the system must be excellent. Let’s discuss these requirements more fully.

One of the first things that must be considered in planning a p.a. installation is how much power is necessary to cover the audience properly. This problem can be solved only by having some knowledge of the acoustic problems involved in distributing sound. In a small living room, a power of two or three watts is entirely sufficient. However, in a large auditorium or at an outdoor gathering or sporting event, an electrical power of as much as 500 watts or more may be required.

There are many factors involved in the determination of the proper power levels. We’ll learn more about these later, but some of these factors are:

1. Noise Level
2. Acoustic Problems
3. Fidelity
4. Loudspeaker Efficiency

**Noise Level.** Whenever there is any appreciable amount of noise, any other sound tends to be masked. You are undoubtedly familiar with the fact that it is much easier to hear some-

one talking in a quiet room than in a noisy one. Conversely, a speaker must talk loudly in a noisy room to be heard. This fact means that the noise level at the location must be taken into account when a p.a. installation is planned. In general, it is necessary that the desired sound be amplified so that it is considerably stronger than the noise level. There are limits to this—if the noise level is too high, as it may be in a factory, it may be impossible to get above it without making the amplified sound so loud that it is actually painful.

**Acoustic Problems.** The loudspeaker cone moves air particles directly before it, and these in turn move other particles at a distance. As this movement fans out, and as the distance between the loudspeaker and the listeners increases, a decreasing amount of sound power reaches individual listeners. Furthermore, much

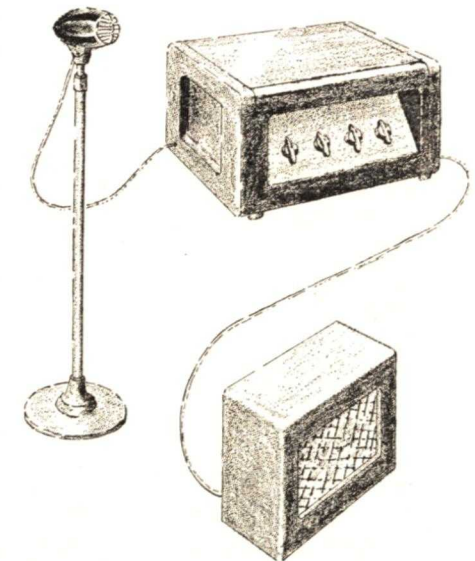

FIG. 1. This is the basic p.a. system—a microphone, an amplifier that builds up the signal from the microphone, and a loudspeaker that converts the electrical signal into sound.

of the sound power is absorbed by the cushions on chairs, by hangings on the walls, carpets on the floors, and by the people and the clothing they wear. Any soft material readily absorbs sound energy. All of these absorptions, plus that of any acoustic treatment that may be placed in a hall, will reduce the sound reaching the rear of the hall appreciably. Outdoors, sound is similarly absorbed by people and dispersed by the wind. All such effects increase the amount of power a p.a. system must produce to give adequate sound coverage.

One acoustic problem that occurs only indoors is caused by sound reaching listeners over two or more paths. For example, if sound reaches a listener directly from the loudspeaker and indirectly by reflection from a wall, the sound traveling over the longer path will arrive later than that over the more direct path. In an extreme case, this can cause an echo effect, with one sound heard separately before the other. If the time difference is too short to amount to an actual echo, the sound arriving over other paths may be sufficiently out of phase to produce a muddled response. This phase difference may be exactly  $180^\circ$ , causing sound cancellation: in fact, it is quite common to find that reflections from the walls, floors and ceilings are such that there are actual dead spots in the hall.

As we shall show later, the reflection problem can be partially solved by acoustic treatment of the room, but it is quite possible that severe reflections will require the use of additional loudspeakers, so distributed that sound energy will be put where and only where it is wanted. Any such

multiple speaker installations will usually require more power.

**Fidelity Requirements.** It is not usually difficult to design a public address system to handle only spoken words. However, when music is also to be handled, the fidelity of the system enters into its design to a great extent. The greater the fidelity requirements, the greater the power requirements. Low frequencies in particular require large amounts of power to be heard at a distance, because the human ear falls off in its response characteristics at low frequencies. Similarly, there is a drop-off in the high-frequency response because of the greater absorption of these frequencies in the acoustic materials of the hall. To make up for these rather large drop-offs, it is necessary to have high powers at the low and high frequencies, and to design the loudspeakers and their baffles to reproduce such frequency ranges properly. Therefore, when high fidelity is required, the power demand is increased tremendously.

**Loudspeaker Efficiencies.** Once the problems of noise, acoustic conditions, and fidelity have been considered, it is possible to determine about what acoustical power will be needed to cover a certain area or number of people outdoors or to cover a certain room volume or number of people indoors. In fact, in later Lessons, we will give tables that can be used, once the necessary facts about the installation are known, for determining roughly the acoustical power needed.

When the acoustical power is known, you can find the electrical power from the loudspeaker effi-

ciencies. The loudspeaker converts electrical power into sound power. Unfortunately, this conversion occurs with extremely low efficiency, so a considerable amount of electrical power is required to produce a small amount of sound power. At best, the ordinary cone-type loudspeaker of the sort used in home receivers has an efficiency of only about 2%. If this cone loudspeaker is placed in a carefully designed baffle, its efficiency rises to as much as 5%. Even the best speakers, using efficient diaphragm driver units in trumpets, have efficiencies of only about 15%, and this is obtained only at a considerable sacrifice in fidelity. In most cases, however, a surprisingly small amount of sound pressure is needed, so it isn't necessary to go to extremes in electrical power to overcome this great loss in the loudspeaker.

Once we arrive at a reasonable estimate for the electrical power required, this sets at least one of the requirements to be made of our amplifier. Thus, if we find that we need 12 watts for a particular small installation, the amplifier must deliver at least this power output.

## GAIN REQUIREMENTS

Turning now to the other end of the system, how much are we getting from the microphone? We shall find in other Lessons that this depends on the kind of microphone, and on the distance between the microphone and the person speaking, as well as on the sound energy delivered by that person. However, even at best, a microphone delivers a power that is only a fraction of a microwatt! Therefore, our amplifier must have sufficient

voltage and power amplification to raise the output of the microphone to the power needed to drive the loudspeaker system. This gives a second requirement for the amplifier—it must have sufficient gain in addition to delivering the required output.

Once we have chosen the microphone, amplifier, and loudspeakers, we are faced with the problems of connecting them together. Often very short leads are all that are required, but sometimes we may have to put our loudspeakers several hundred feet away from the amplifier. As you will learn later, special impedance-matching methods must be used in this case.

Another problem rises when a sound system is used for amplifying music. To get fidelity, it is frequently necessary to use combinations of low-frequency and high-frequency loudspeakers. The power distribution problem is complicated by this, because we must not only match impedances properly, but also use frequency-dividing networks so that the speakers will get power at the frequencies they are designed to handle most effectively.

Further, we may not always want to use only a microphone with the sound system. Very frequently phonograph records are played over p.a. systems, for example, and occasionally radio programs are reproduced over them. The amplifier must therefore be capable of operating from a phonograph pickup or from the audio output of a radio receiver unit as well as from a microphone. These devices all have different output levels and are of different impedances. This brings up another problem in imped-

ance matching, this time at the input of the amplifier.

Furthermore, the use of several input devices introduces the problem of switching from one to another. We can just unplug one and plug in the other, or just throw a switch, but, if we do, we will get a very loud click or pop from the loudspeaker. Most p.a. systems have some form of fading control, so arranged that the output of one or the other of the devices can

be reduced to the minimum and then the output of the other can be raised gradually, or so arranged that they can be mixed together.

We are introducing you to these various public address problems so that you can better appreciate the material in the next several Lessons. Now that we have a general understanding of some of the problems, we can go on to a more detailed study of the amplifier itself.

## The Decibel and Power Ratios

In public address work, we are dealing with extremely large power ratios. The acoustic power at the microphone is exceedingly small, whereas the sound output of the loudspeaker may be so loud that it is actually painful. The power ratio (output power divided by input power) is therefore so large that the figures involved become inconvenient to handle. It is not unusual to have gain figures representing power increases of as much as a billion times. For convenience, it is desirable to express the gains and power ratios involved in p.a. work in some way that will not demand such large numbers. This has led to the adoption of a special unit called the decibel, which we shall discuss in a moment.

Another factor that makes it desirable to use decibel units is the fact that the human ear responds exponentially to sound powers, rather than linearly. This means that if we double the sound power, we don't get twice as much sound as far as the ear is concerned—in fact, we can just

barely detect the fact that the loudness of the sound has increased.

In other words, the human ear is so constructed that any complex sound must be doubled in power before it sounds louder. This is true at both low and high sound levels, provided the original sound is loud enough to be heard at all. For example, going from 2 to 4 *microwatts* produces a detectable increase in loudness; the apparent increase produced by going

TABLE 1

db	Power Ratio
1	1.25
2	1.6
3	2.0
4	2.5
5	3.2
6	4.0
7	5.0
8	6.4
9	8.0
10	10.0
15	32.0
20	100.
30	1000.
40	10,000.
50	100,000.
60	1,000,000.
100	10,000,000,000.
110	100,000,000,000.
120	1,000,000,000,000.

TABLE 2

Power Ratio	db
1.0	0
1.5	1.8
2.0	3.0
2.5	4.0
3.0	4.8
3.5	5.4
4.	6.0
6.	7.0
7.	8.4
8.	9.0
9.	9.5
10.	10.0
15.	11.8
20.	13.0
30.	14.8
40.	16.0
50.	17.0
60.	17.7
100.	20.0
200.	23.0
500.	27.0
1000.	30.0

from 200 to 400 *watts* is no greater.

This peculiar property of the ear is another reason why the use of decibel units in discussing sound power ratios is convenient, because the decibel system expresses these ratios in terms of what the ear can hear. Let's go on now and learn what these important units are.

### DECIBEL DEFINITION

The decibel (usually abbreviated db) is logarithmically related to the ratio of two powers by the formula

$$db = 10 \log_{10} \frac{P_1}{P_2}$$

where  $P_1$  and  $P_2$  are the powers. To solve this equation, the two powers are inserted and their ratio determined. Then the logarithm to the base 10 of this power ratio is looked up in a table. Ten times this logarithm is the decibel gain or loss.

In this Lesson, we cannot go very far into the subject of logarithms. Briefly, however, a logarithm of a number is the power to which a base

number must be raised to equal the original number. For example, you know that the second power of ten ( $10^2$ ) equals 100. In the common logarithms that use the base 10, 2 then becomes the logarithm of 100.

It is unnecessary to use the db formula because there are tables available, such as Tables 1 and 2, that give the decibels corresponding to certain power ratios. Furthermore, there are meters that are designed to indicate decibels directly. We'll say more about these shortly.

### USES OF DECIBEL UNITS

Although the decibel was originally developed purely from power ratios, careful tests have indicated that one decibel of power increase is just about the smallest change in power that can be detected by the average human ear. This change is detectable only when it consists of a single pure tone and only when the test is carried out under carefully controlled conditions. For complex tones—music, for example—a change of 3 decibels is ordinarily necessary to produce a detectable volume level change. Table 1 shows that a 3-decibel change indicates a power ratio of 2, meaning that the power must be doubled before we can tell that the complex sound is any louder. If we want to make it still louder, the power must be doubled again, and so on.

Since the decibel expresses the relationship between two powers, it is a convenient unit with which to measure power gains or losses. Furthermore, it can be used to express sound power or electrical power in terms of some reference value of power. The reference level commonly used when sound powers are given in decibels is

the sound power that is just barely audible to the average ear—in other words, the threshold of hearing of the average person. For convenience, technicians do not usually bother to mention the reference level when they talk about sound powers in db, but you should always remember that a sound level expressed in db is really the level with respect to the threshold of hearing. For example, the noise level in the average home living room has been found to be about 55 db; from what we just said, you know that this is 55 db with respect to the reference level, or about 300,000 times the power of the least audible sound.

Notice how much more convenient it is to say “55 db” instead of “300,000 times the power of the least audible sound.” Obviously the decibel measurement is far easier to use in speech or writing. Furthermore, stating the noise level in db lets us get some idea of just how noisy the location is. Since each 3-db increase produces a barely audible increase in loudness, we know that the noise is  $55 \div 3$  or about 18 steps up the scale of comparative loudness.

Electrical powers are also often expressed in decibels in sound work. Here again, some power level must be used as a reference. In the past, considerable confusion arose from the fact that three different reference levels were used by different branches of the communications industry—the telephone company and the radio amplifier manufacturers, particularly, differing in their standards. Of these three older standards, a reference level of 6 milliwatts was the most commonly used; in fact, it still is in sound work. However, in recent years,

there has been an attempt in the communications field to secure universal use of a new standard based on a 1-milliwatt reference level. This new unit is used throughout both the broadcast industry and the telephone companies. As a result, it is gradually spreading to sound equipment, and may eventually replace all of the older reference levels. Although the new unit is still a decibel, because the only change has been in the reference level, it is a common practice to indicate the new unit as a “VU” or “dbm” instead of “db” to avoid confusion.

In either case, the reference level is assumed to be the zero db level. Any power that is higher than the reference level is therefore a power increase above the reference level and is considered to be a plus db value. Power levels below the reference level are minus db values.

Table 3 gives some typical db levels based on the 6-milliwatt (.006 watt) and on the 1-milliwatt (.001 watt) reference levels. There is no need for you to try to memorize these values. All you need to do now is to learn how they are used. To that end, let's take a few practical examples of the use of decibels in sound work.

Let's suppose we have a case in which 60 watts of power fed through certain loudspeakers will produce sufficient audio power to cover an audience properly at the desired level. From Table 3, we see that this is an output of about 40 db above the reference level of .006 watt.

A typical microphone may have an output of -60 db, which means that its output is 60 db *below* the reference level of .006 watt. Therefore, we have to raise the microphone output of

-60 db to a plus value of 40 db. This means that the amplifier must have an over-all power gain of 100 db. The output power of the amplifier is therefore about ten billion times that of the microphone!

An important point to remember is that we have to double the output

of these two—we get somewhat less distortion by running an amplifier at less than its rated output, and of course one having the higher power rating would be better able to handle high power peaks without too much distortion. The 20-watt amplifier may therefore be the better of the two, on

TABLE 3

Reference Level: 0 db = 1 milliwatt			Reference Level: 0 db = 6 milliwatts	
Watts		db	Watts	
1000.		+60	6000.	
100.		+50	600.	
10.		+40	60.	
1.		+30	6.	
.1		+20	.6	
.01		+10	.06	
.001		0	.006	
.000 1		-10	.000 6	
.000 01		-20	.000 06	
.000 001		-30	.000 006	
.000 000 1		-40	.000 000 6	
.000 000 01		-50	.000 000 06	
.000 000 001		-60	.000 000 006	
.000 000 000 1		-70	.000 000 000 6	
.000 000 000 01		-80	.000 000 000 06	
.000 000 000 001		-90	.000 000 000 006	
.000 000 000 000 1		-100	.000 000 000 000 6	

power before we can get a noticeably stronger signal. If one amplifier is rated at 15 watts, and another is rated at 20 watts, their power difference is only slightly more than 1 db. Obviously, therefore, the 20-watt amplifier will not produce any appreciably louder sounds than the 15-watt one. This doesn't mean that the 20-watt amplifier wouldn't be the better choice

the basis of freedom from distortion, but it will not be any louder for complex sounds. If we had a 15-watt amplifier, we would have to go to a 30-watt amplifier to get a noticeable increase in loudness level. Similarly, we would have to go from 100 watts to 200 watts to get an appreciable increase in sound at a higher power level.

# Amplifier Specifications

There are many types and sizes of p.a. amplifiers. In addition to differing in amount of electrical power output and in fidelity of response, they have different power-supply requirements, are capable of operating from different types or numbers of microphones or other inputs, and have different input and output impedance characteristics. All these factors must be considered in the choice of a particular amplifier for a specific job. To assist in making this choice, manufacturers' catalogs give the following information about each amplifier listed, either in the form of a complete description or as tabulated data:

- Power Output
- Gain
- Frequency Response
- Hum Level
- Input Impedances
- Output Impedances
- Power Required
- Tubes
- Physical Specifications

In addition, you may find a few other special features described, such as the kind of tone control.

Naturally, it is important for you to understand the real meaning of each of these specifications. Let's examine the important ones now to see just what they mean.

## POWER OUTPUT

The power output is usually stated in watts, although you may sometimes find that the manufacturer also gives the output level in decibels above the 6-milliwatt reference level.

Some manufacturers give both a

"normal" and a "peak" output rating. In these cases, the *normal* output level is the output for a certain specified percent of total harmonic distortion. The peak value is the *maximum* amount of power that can be obtained from the amplifier without regard to distortion.

It is common practice to select 5% total harmonic distortion as the acceptable distortion for normal output, because, at this level, the amount of third harmonic distortion is not so high that it is seriously objectionable. To obtain the power rating, therefore, the manufacturer increases the input while analyzing the wave form of the output. When the harmonic distortion reaches the value chosen, such as 5% (or 2% in the case of high-fidelity equipment), the output is measured. This becomes the *normal* power output. Then, the input is increased further until the point of maximum power output is reached. This too is measured. This becomes the *peak* rating.

If you find only one output value listed for an amplifier, you won't always know whether the manufacturer means normal output or peak output. The normal output is considerably less than the peak rating; therefore, if the rating given is close to the value needed for the installation in such a case, you would do well to determine just which is meant before purchasing the equipment.

Amplifiers intended for public address can be grouped into low-power, medium-power, and high-power classes. There is no strict

border line between these classes, however. In general, any amplifier under about 10 to 15 watts is a low-power type, those between this value and about 50 watts are medium power, and those above 50 watts are considered to be high power.

As we pointed out while discussing decibels, it takes a doubling of the power output to produce a noticeable increase in volume, so of course amplifier manufacturers do not make many different sizes in any of these groups. Usually a manufacturer makes only 4 or 5 amplifiers in each series—say a low-power amplifier of about 8 to 10 watts, a medium-power one of 15 to 20 watts, another somewhere between 35 and 50 watts, and then perhaps a high-power one. The outputs chosen are selected with the idea of having some amplifier in the line fairly close to any output that may be desired.

Manufacturers usually also make amplifiers for battery or a.c.-d.c. operation. These are not usually merely the standard a.c.-operated amplifiers with modified power supplies, because, for battery operation at least, it is necessary to make amplifiers as economical of power as possible, something that designers of a.c. equipment don't worry much about. We'll discuss this later.

## AMPLIFIER GAIN VALUES

Because of the extremely high power ratios involved in public address work, it is standard practice to give the gain of amplifiers in decibels. Because these amplifiers are commonly used with phono pickups in addition to microphones, most amplifiers have input circuits for each.

Since the output of a phonograph-record player is much higher than that of a microphone, less gain is needed for the phono channels. Therefore, the gain values are usually given for each input—some such value as 100 db gain for microphone and perhaps 40 to 60 db for phonograph. As you learned from Table 1, a db gain of 100 represents a power ratio of ten billion.

Sometimes, in connection with the gain values, the manufacturer will list specific types of microphones or phonograph players that are suitable for the particular amplifier. If such information is not given, it may be necessary to make a calculation to determine whether a specific input device can be used with a particular amplifier. In such cases, the output power rating must be converted to decibels. Let's suppose the amplifier is rated at 60 watts and has a gain of 100 db for the microphone channel. From Table 3, we find that a 60-watt output represents +40 db, based on a 6-milliwatt reference level. Since the output of our amplifier is +40 db, and the gain is 100 db, the amplifier will deliver its rated output of 60 watts if the input is -60 db. That is, a gain of 100 db will raise a level of -60 db to +40 db (100 minus 60 equals 40).

Microphones have different outputs ranging all the way from -40 db to perhaps -100 db. (This is from the 6-milliwatt reference level.) Naturally, if you have a microphone capable of giving -50 db, it has more than enough output to drive the amplifier we are discussing to full rated output. It will work satisfactorily with the amplifier because we can always

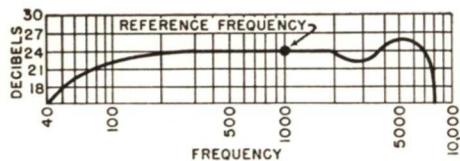

FIG. 2. This frequency-response curve shows the db output of an amplifier at various frequencies.

reduce the gain with the volume control. On the other hand, a microphone with an output of  $-70$  db will not permit this amplifier to give full rated output. If we must use a microphone of this kind, we will have to have a preamplifier with a gain of at least 10 db to raise the microphone signal level from  $-70$  db to  $-60$  db so that the amplifier can be operated at full output.

This discussion shows you why the decibel is used in p.a. work. With its aid, it is rather simple to see just what will work with what. Any power losses or power gains in the systems can be taken into consideration simply.

## FREQUENCY RESPONSE

The amplitude or harmonic distortion is given along with the power output rating, or is understood to be at some standard level when normal outputs are given. However, in addition, we can have frequency distortion—the limitation of the frequency range over which the amplifier will operate with a reasonable output. In public address work, the frequency response is rather important. If voice alone is to be handled, there is no need for very low notes, nor is there need for high notes above 5000 cycles. If the system is to have high fidelity, on the other hand, you'll want as wide a frequency response as is obtainable

within the price range in which you are interested.

To arrive at the frequency response, the manufacturer determines the input at a reference frequency, usually 1000 cycles, that will produce the rated output. Then, the same input is fed into the amplifier at other frequencies. The amplifier output at each of these various frequencies is then expressed either in decibels or in terms of the number of decibels it is up or down from the output at the reference frequency.

Data on frequency response are frequently given in the form of response curves. In the type shown in Fig. 2, the output is given in terms of the rated output of the particular amplifier. A somewhat more common form is that shown in Fig. 3, in which the response at various frequencies is given in terms of its db variation from the reference frequency output. This curve applies to any amplifier having this response, regardless of its rated db output level.

A frequency response curve is ordinarily carried out only to the points at which the frequencies fall off 3 db from the reference value. Beyond these points, it is understood that the characteristic may have peaks, but in general, will be worse than 3 db off from the reference level. Therefore, whenever the manufacturer says that an amplifier is "flat within 3 db from

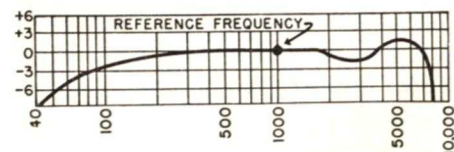

FIG. 3. This frequency-response curve shows how many db up or down the amplifier output is at various frequencies.

40 to 10,000 cycles," he means that the output will vary slightly but will remain within 3 db above or below the output at 1000 cycles between these limits. Notice that the curves shown in Figs. 2 and 3 are flat within 3 db from 80 to about 7500 cycles.

Many manufacturers give information on the effects of the tone controls on the frequency response. They will state that the tone control raises or lowers the output so many db at a given frequency. This will give a general idea of what happens to the response curve as the tone controls are varied.

## AMPLIFIER HUM LEVELS

Naturally, the output hum and noise levels from an amplifier must be just as low as possible for best results. In any amplifier of reasonably good design, the noise level is far below that of the hum.

In high-fidelity systems, the hum voltage applied to the loudspeaker must be very small to prevent excessive hum output. The hum level is not quite so important in a low-fidelity system, however, because the low-frequency output is usually attenuated.

The manufacturer commonly gives the hum level as so many db below rated power output. A value around 35 to 50 db down is considered acceptable for general-purpose amplifiers.

When the noise level is given too, it is likewise given in terms of decibels down.

## INPUT IMPEDANCES

When an amplifier is given a certain rating, it is assumed that its input and output will be properly

impedance-matched so that the maximum power transfer will occur. Therefore, the number and impedance values of the input channels are important amplifier ratings.

The simplest amplifier may have only a phonograph input; very elaborate ones may have provisions for three or four microphones and perhaps two or three phonograph players. Because it may be desired to fade one signal out and fade another in gradually, without affecting the strength of any other signals, all of these input channels are usually fed through separate preamplifier stages, whose outputs are then combined in a mixing circuit arrangement. We'll study these amplifiers in more detail later.

Some microphones, such as the crystal types, are high-impedance devices that should feed into the grid input circuits of tubes. As a practical matter, you know that the grid circuit must have a d.c. path to the cathode. Since a resistor of around 100,000 ohms is commonly used to provide this path, it is standard practice to consider a high impedance input to be approximately 100,000 ohms for microphone services.

Microphones such as the dynamic types have low impedances, which are brought up to standard line impedances by means of matching transformers built into the bodies of the microphones. For low-impedance microphones, therefore, the input of the set has to be a transformer rated at some standard line impedance such as 250 or 500 ohms. Because high-impedance inputs are less costly, basic amplifiers are usually supplied with high-impedance inputs, with low-impedance inputs being available at a



slight extra cost. The type of input impedance is usually optional in the more elaborate amplifiers.

Phono channels are today practically all high-impedance types because it is standard practice to use crystal pickups. If magnetic pickups are used, it is expected that a matching transformer will be used to match the pickups to the grid circuit of a tube or to match from a standard transmission line to such a grid circuit.

### OUTPUT IMPEDANCE

It is standard practice today for practically all amplifiers to have a tapped arrangement for matching various loudspeaker voice coil impedances. Values of 2, 4, 6, 8, and 16 ohms are usually available. In addition, most amplifiers also have provision for at least a 500-ohm line. Some of the more elaborate types have additional taps for 125 ohms and 250 ohms for use when lines are connected in parallel.

In addition to giving the output impedance values, the manufacturer will usually mention the method used for making connections to the output terminals of the amplifier. In some instances, these terminals are just brought out to terminal strips. In others, the terminals are brought out to sockets into which the loudspeaker lines are plugged, the proper impedance being selected by turning a switch. Such refinements as this latter are not absolutely essential, but they are helpful, particularly for amplifiers that are going to be set up and taken down frequently under conditions under which different types of loudspeakers may be needed. We shall go further into the subject of loudspeaker

connections later (in another Lesson).

### POWER REQUIREMENTS

Like radio devices, public address amplifiers operate from power supplies. It will do no good to find exactly the right amplifier for your installation if it will not operate from whatever power is available. Therefore, although the power requirement is usually far down on the list, it is one of the first things you should look for.

Of course, 115-volt, 60-cycle a.c. power is commonly available throughout the United States, and most p.a. amplifiers are designed to operate from such a.c. power lines. There is a wide variety of amplifiers available for such operation, so the choice of a particular amplifier depends on other considerations.

However, there are many cases where the proper power lines are not available. In some of the larger cities, for example, there are large districts in which only 110-volt d.c. power is available. In a few localities, the power lines supply only 25-cycle a.c. Special amplifiers are rarely available for such power supplies. The only thing that can be done in most instances is to obtain an inverter unit that will convert the available power to 60-cycle a.c. Such inverter units are available from radio supply houses.

Public address equipment used in a sound truck must operate either from storage batteries or from some form of power supply carried with the amplifier in the truck. In the case of high-power units, it is standard practice to equip the truck with a small a.c. generator driven by a gasoline motor. Because of the efficient cir-

cuits incorporated in modern amplifiers, however, it is practical to operate the small units from 6-volt storage batteries. Vibrator-type power supplies are used in such cases. Most such units supply enough 115-volt, 60-cycle power to operate a record player as well as an amplifier.

Naturally, when we are dealing with special units of this kind, it is particularly important that the required power levels be calculated accurately. Large sound systems drain storage batteries quickly and are rather costly. On the other hand, units that are too small are practically worthless. It is therefore necessary to select equipment that is adequate for the job but not more powerful than it needs to be.

### TUBES

In practically all cases, manufacturers list the number and types of tubes used in p.a. amplifiers. This information is helpful if you find that some of the tubes listed are not the types that are commonly available in your locality, because then you can stock up on an extra set or so. The tube list will also give you a general idea of the circuits that are used, and from the power output rating, you can get an idea of how hard the tubes are being driven.

### PHYSICAL SPECIFICATIONS

It is important that you know the dimensions and weights of public address units, particularly when they are to be permanently installed in a given location. The kind of housing, too, is frequently important. Sometimes you will want the amplifiers mounted in a standard rack. In other cases, you will want them to be enclosed in a metal shield or case, which is common practice for most amplifiers today.

The manufacturer may also describe the color and type of decoration on the housing, and, of course, he will usually show photographs of the general appearance of the amplifier. Naturally, it is always desirable to have a unit that is physically pleasing in appearance whenever it is to be located where it will be used by the public. Therefore, although such considerations are less important than getting the right technical equipment, they must be taken into account.

Now that we have a general idea of the data that can be expected in the manufacturer's literature, let's go on and briefly examine some typical p.a. amplifiers to see how they differ from standard audio amplifier equipment like that found in radio receivers.

## Power Supplies, Output Stages, and Drivers

As we have mentioned before, the public address amplifier is essentially like the audio amplifier in a standard radio receiver. As a matter of fact, the low-powered types are, for all practical purposes, identical with

such amplifiers. Not only are the circuits similar, but also the same kinds of tubes are used. The only radical difference is that low-powered p.a. units usually require one more voltage amplifier stage so that they will

have sufficient gain to operate from the very low output of microphones. Higher-powered units differ more markedly from the audio sections of radio receivers, mostly because different tubes and circuits are needed to permit the handling of the increased power.

In the following discussion, we shall not go deeply into the basic theory of voltage and power amplifiers, because you have already studied this in other Lessons of this Course. (If you are hazy on certain points, review your Lessons on low-frequency amplifiers and on power supplies.) Instead, we shall point out the important differences between radios and p.a. systems. Let's start with power supplies.

## POWER SUPPLIES

The smaller p.a. units operate from power supplies that are identical with those in standard radio receivers. The most common power supply uses a standard power transformer, a full-wave rectifier, and a filter, although you will find that a few of the small portable p.a. units use a.c.-d.c. supplies. The small mobile p.a. systems that are designed to operate in trucks use vibrator-type power supplies operating from a storage battery, almost identical with supply units you find in auto-radio receivers except that they are capable of delivering somewhat more power. If we consider devices like hearing aids to be public address-systems in miniature, we will even find batteries are used to furnish power directly.

Therefore, in all low-powered p.a. systems, we can expect to find power supplies that are identical with types

we have included before in our study of radio receivers. It is only when we get up in the high-power units that we find much difference.

In high-power applications, it is standard practice to use a power supply with a power transformer, operating from 60-cycle a.c. If the equipment is to be used in mobile services, it is commonly operated from a gasoline-engine-driven motor-generator that develops the necessary 110-volt, 60-cycle a.c. In districts with d.c. power or 25-cycle a.c., a motor-generator would be used to deliver the 110-volt, 60-cycle a.c. Hence, you will usually find that all high-power amplifiers are alike in their power supplies to this extent.

Voltages around 300 to 400 volts are easily obtained from a transformer power supply. Receiver-type rectifier tubes may be used; if the current requirements exceed the rating of a single tube, two tubes can be used with the sections in parallel,\* as in Figs. 4A or 4B. These two connections both deliver twice the current of a single tube. The only difference is that you will get only half-wave rectification, with consequent hum, if one tube fails in the circuit shown in Fig. 4A. The circuit in Fig. 4B will still give full-wave rectification as long as the remaining tube lasts. Of course, this tube will be heavily overloaded, so it won't last long.

As we shall soon see, some p.a. systems use power output tubes operated in class AB<sub>2</sub> or even in class B. Because of the very wide changes in current requirements between the no-load and full-load conditions, power supplies used with such output tubes

must have good regulation. Ordinarily, this means that the transformer and choke coils must have low resistance, and that a very high bleeder current must be drawn. This increases the current requirements.

Since the final stage requires more plate current than any other, its cur-

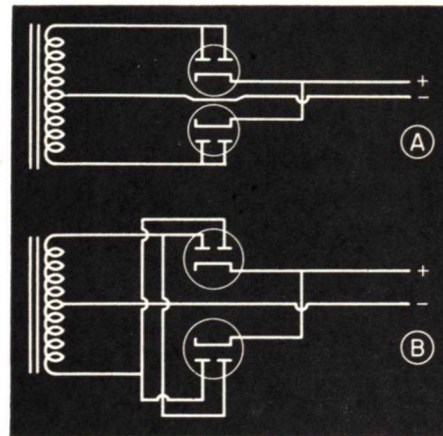

FIG. 4. Two typical full-wave rectifier circuits used in p.a. power supplies.

rent is frequently taken directly from the rectifier output without passing it through the filter choke. This is permissible because there is no amplification beyond the output stage, so any hum developed is swamped by the desired signal. When the output current does go through the filter, a swinging choke is commonly used as the input choke to help keep the output voltage constant in spite of the high current changes between no-load and full-load conditions.

In some of the p.a. units of the highest powers—those rated well over 100 watts—the power output tubes are actually small transmitting tubes intended to operate on higher voltages than are applied to receiving tubes. The power supplies of such units must, of course, be designed to deliver

appropriate voltages—around 800 to 1500 volts. This means that the secondary of the power transformer must have a higher voltage rating than is usual in p.a. equipment. To withstand the higher voltages, special rectifier tubes of the types that are more commonly found in amateur transmitting equipment are sometimes used. In addition, the filter condensers must be designed for these high voltages, which means that they are usually oil-filled paper condensers of the kind used in transmitters. The need for this special, expensive equipment makes high-power amplifiers disproportionately costly. For this and other reasons, high-power p.a. units of this kind are rather rare; when high powers are needed, it is common practice to use several amplifiers connected in parallel instead. The use of several smaller amplifiers is preferable because it is lower in cost, gives a more flexible arrangement (since the system can be expanded at any time by adding more units), and simplifies future servicing.

## POWER OUTPUT TUBES

As you might expect, beam power and pentode tubes, which have high power sensitivity and high plate efficiency, are used as the power output tubes in practically all p.a. amplifiers. Obviously, if a triode tube requires 40 volts as the grid signal voltage for full excitation, and a pentode or beam tube is capable of giving the same power output with only 15 volts of grid drive, the latter is more desirable, since much less voltage amplification is necessary ahead of it. These tubes also have an advantage over triodes in that they convert

somewhat higher percentages of their plate power into usable power output.

The one advantage of the triode over the beam power and pentode tubes is that it has far less distortion. However, modern inverse feedback circuits make it possible to obtain reasonable fidelity from pentode and beam power tubes. Therefore, the triode power tube has practically disappeared from the p.a. field except for very high-fidelity systems.

In general, the types of tubes used in p.a. amplifiers are exactly like those in radio receivers, except that, because of its high power capabilities, the 6L6 tube is more commonly used in p.a. work than it is in radio receivers. Even the smaller receiver-type tubes are commonly used, sometimes in circuits that get more from them than is required in radio receivers.

**Class A Operation.** The power output stages of p.a. amplifiers are most commonly operated in class A,

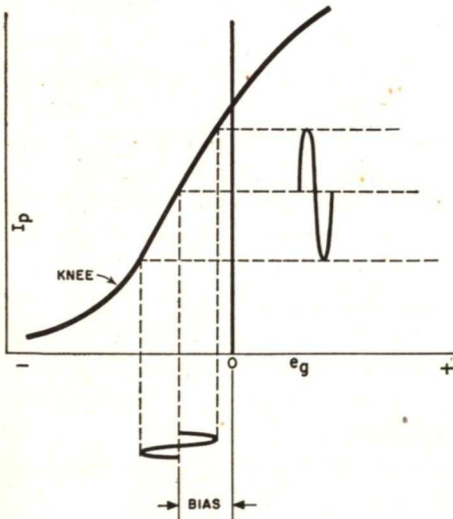

FIG. 5. This shows class A operation of an amplifier. The input signal swings over the straight part of the tube characteristic, and the grid voltage never goes positive.

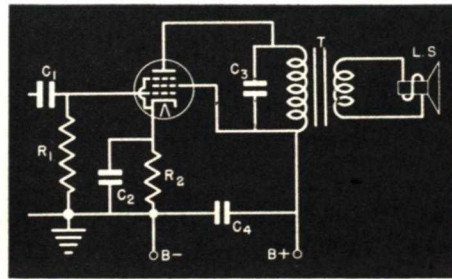

FIG. 6. A single-ended class A stage.

just as are those in radio receivers. In this class of operation, the operating point of the tube is set by the bias on the midpoint of the straight portion of its characteristic (see Fig. 5). The complete cycle of the incoming signal is reproduced in the plate current. As long as the input signal is not so high that it swings as low as the bottom knee of the characteristic or higher than the zero bias point, this class of operation is reasonably free from distortion. This matter of distortion is important because it places the real limit on power output. We can get only so much power output at a given distortion level from any particular tube once its operating condition has been specified. When the acceptable distortion level has been chosen, the drive or grid signal applied to the power output tubes can be increased only until this distortion percentage is found in the output.

In applications in which the tone quality is not very important and low powers are all that is required, the single-ended class A stage like that in Fig. 6 is sometimes used. If higher output levels are required and somewhat better tone quality is desirable, a push-pull circuit like that shown in Fig. 7 is used. Here, because the even

harmonics are cancelled in the output transformer, it is possible to get greater power output from each output tube than is possible in the single-ended connection shown in Fig. 6. As a matter of fact, properly increasing the grid drive permits about two and one-half times as much power to be obtained from a pair of tubes in push-pull as can be gotten from a single tube for the same relative amount of distortion.

Both the single-ended and push-pull class A stages are usually self-biased by a resistor in the cathode circuit. However, there are exceptions—the bias can be obtained from the power supply, making it a form of fixed bias. Such a system is rather commonly used with push-pull outputs, because it is desirable to balance plate currents of the push-pull tubes. Therefore, as we shall see later, the grid returns are split and brought back to separate adjustable bias resistors in the power pack; it is then possible to adjust the bias to produce equal plate currents.

The circuits in Figs. 6 and 7 use resistance coupling to the power tube grids. It is possible to use transformers, of course, but an input trans-

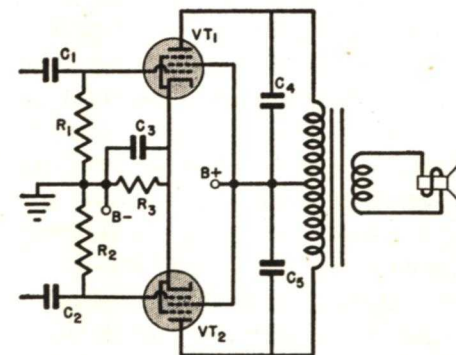

FIG. 7. A push-pull class A stage.

former is bulky and rather costly. Furthermore, unless it is of high quality it will introduce considerable frequency distortion and also pick up stray hum fields.

When resistance coupling is used at the input of the push-pull stage, a phase inverter must be used. Any of the types that you studied in your fundamental Lessons may be found in p.a. amplifiers. Several typical schematics of phase inverters are shown in Fig. 8. In each instance, the necessary  $180^\circ$  phase shift is obtained either by an additional tube or, as shown in Fig. 8C, by making use of the fact that the cathode voltage is out of phase with the plate load voltage.

If a transformer input is used for the push-pull stage, of course, a single-ended driver stage can be used.

## GETTING MORE POWER

Once we have reached the maximum permissible output with a particular tube in class A operation, the only way of getting more power output is to change the conditions of operation or change the tube. Equipment designers usually prefer to use more efficient classes of operation, since transmitter tubes, the only types capable of giving more power output, are expensive.

Instead of class A, we can use classes  $AB_1$ , or  $AB_2$ , or even class B provided we use a push-pull circuit. The power output increases remarkably—if two tubes deliver 18 watts in class A push-pull, they may give 25 watts in  $AB_1$ , 45 watts in  $AB_2$ , and 60 watts in class B.

Fig. 9 shows the difference between these classes of operation. The class

A grid signal is limited so that the operation remains over the straight portion of the characteristic between the lower knee and the zero bias line. The plate current change for class A operation here reaches the peak value represented by 1. Naturally, the greater this amplitude can be made, the greater the amount of signal power output. Therefore, if we move the operating point down near the knee of the curve, we can apply a higher grid signal and produce AB<sub>1</sub> operation. The plate current swing for this class of operation is shown at the

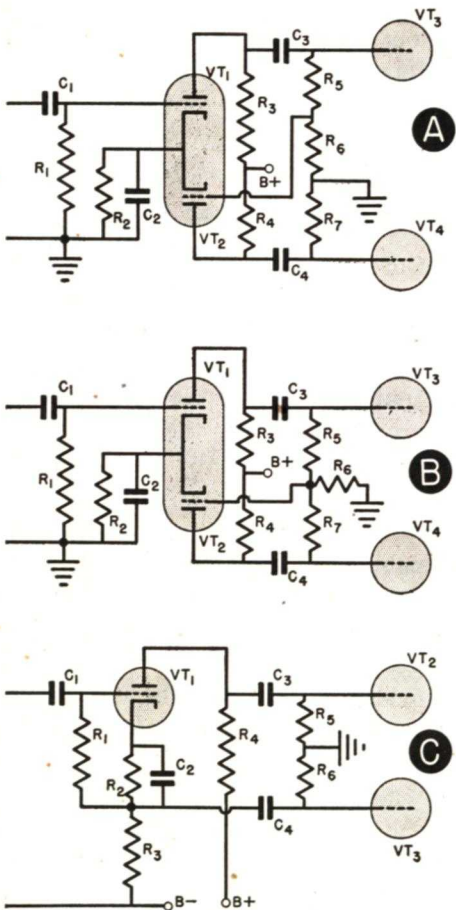

FIG. 8. Typical phase-inverter circuits.

right at 2. Notice that amplitude 2 is higher than 1; this means a greater amount of power output is obtainable. However, the lower half of this plate current cycle is flattened out, meaning that a large increase in even-harmonic distortion has occurred. This distortion would make class AB<sub>1</sub> operation undesirable were it not that push-pull operation fortunately eliminates the even harmonics.

Increasing the grid drive more produces class AB<sub>2</sub> operation, in which the grid actually goes positive for a small portion of the cycle. This operation gives even greater power output, shown by the fact that peak 3 is higher than either 1 or 2.

Finally, when we move the operating point to class B operation, right at the cut-off bias level, only one-half of each cycle of the incoming grid signal is reproduced in the output. The plate current for this class is represented by peak 4, which is much greater than that of any of the preceding classes of operation. When two tubes are operated in class B push-pull, one tube furnishes power for one-half cycle, then it is cut off while the other tube is delivering power.

In class AB<sub>1</sub> operation, in which no grid current is permitted to flow, it is possible to use the same kinds of circuits as in class A operation. In class AB<sub>2</sub> and class B operation, however, the grids of the power output tubes draw current during small portions of the grid cycle. As a result, there is a power dissipation in the grid circuits of the tubes; this power must come from the driver stage. Furthermore, to avoid extreme dis-

tortion, the total grid circuit resistance must be kept very small so that there will be but a small voltage drop while grid current is flowing.

For these two reasons, resistance coupling is not used for class AB<sub>2</sub> or class B operation. Instead, the drive signal is applied through a specially designed input transformer that has a secondary winding with very low resistance or through a cathode follower circuit like that shown in Fig. 10. In the latter case, the "load" on the driver tubes VT<sub>1</sub> and VT<sub>2</sub> consists of the coil L<sub>1</sub> and the cathode resistors R<sub>2</sub> and R<sub>4</sub>. The low-resistance coil is in the VT<sub>3</sub> and VT<sub>4</sub> grid circuits, so grid losses are avoided. This connection provides a good impedance match between the drivers and the output tubes and thereby reduces distortion. Incidentally, the drivers VT<sub>1</sub> and VT<sub>2</sub> are actually small power tubes (operating in class A) that are driven by a voltage amplifier and a phase inverter.

For these classes of operation, it is desirable to have the grid bias of the power tubes adjustable so that the plate currents can be balanced. The

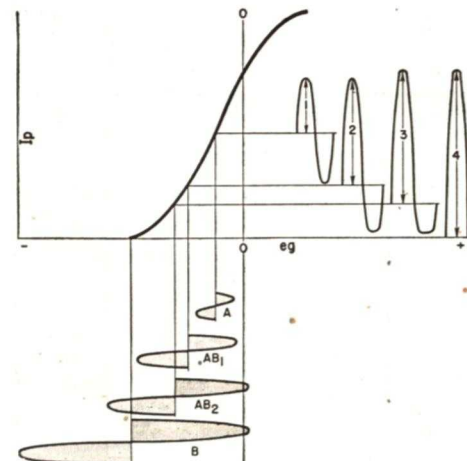

FIG. 9. Four classes of amplifier operation.

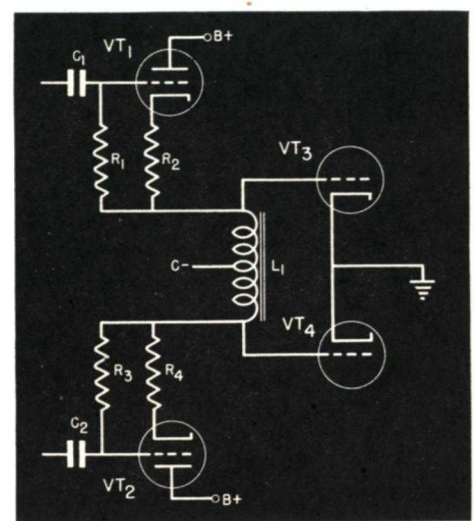

FIG. 10. A cathode-follower circuit used to feed the output stage in amplifiers operated in class AB<sub>2</sub> or B.

balancing arrangement shown in Fig. 11 is commonly used. Adjusting the two potentiometers R<sub>1</sub> and R<sub>2</sub> makes it possible to get the plate currents equal and thus minimize the distortion that will naturally occur with these classes of operation. Incidentally, since the bias is at the cut-off value for class B operation, it is not practical to use self-bias for the power tubes—the bias must be supplied by a separate source such as the power supply.

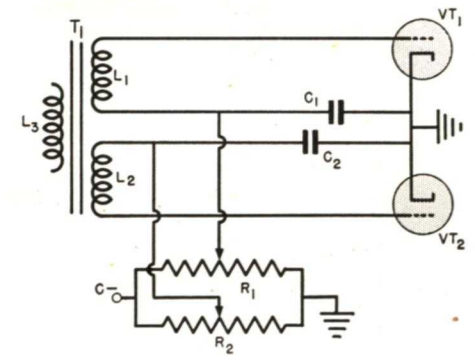

FIG. 11. The plate currents of the two tubes are equalized by adjusting R<sub>1</sub> and R<sub>2</sub>.

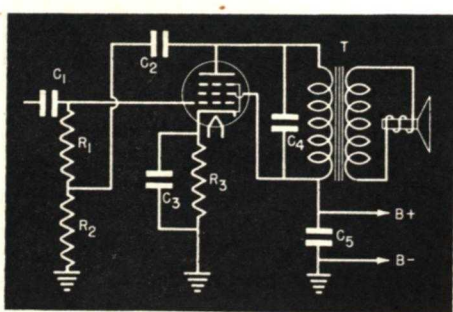

FIG. 12. One method of introducing inverse feedback. The feedback path consists of  $C_2$  and  $R_2$ .

A family of tubes that cut off at zero bias was once developed for class B operation. These tubes, of which the 6N7 is an example, require no external bias at all, and the signal swings for a half cycle into the positive grid region. Such tubes are not used in modern amplifiers, but you may find them in some of the older ones.

The problem of supplying an input signal to a class  $AB_2$  or class B stage frequently means that the tubes preceding the power output tubes must be small power tubes themselves. The required grid input, although it may be only a fraction of a watt, is frequently more than the ordinary voltage amplifier tube is capable of supplying.

**Inverse Feedback.** Any of the forms of inverse feedback that you studied in your fundamental Lessons may be found in public address systems. The feedback may just be across the output stage—from the plate to the grid circuit, for example—or it may be over a loop of several stages. We'll see some typical diagrams later, in addition to the examples given in Figs. 12 and 13. To

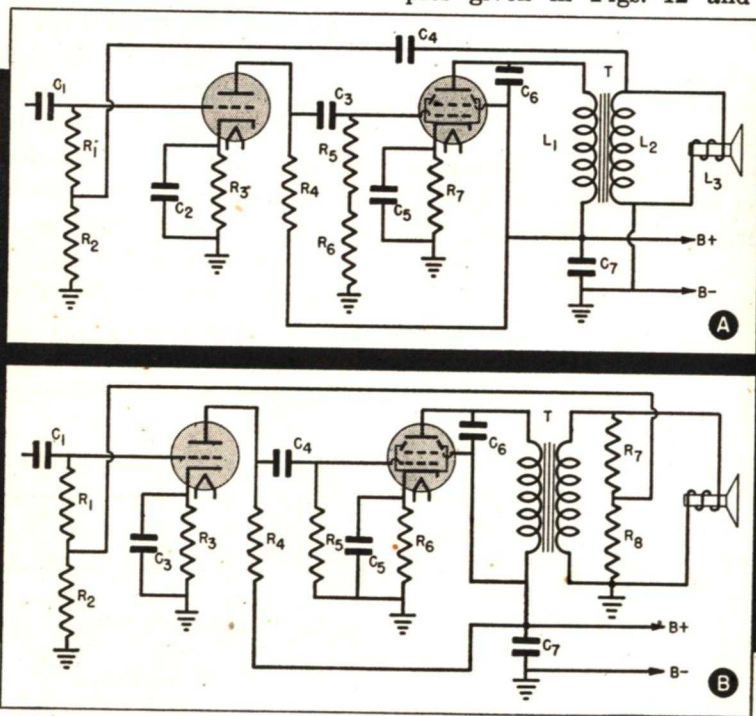

FIG. 13. Multistage feedback circuits. The feedback path in A consists of  $C_4$  and  $R_2$ . In B, the fraction of voltage that is fed back is determined by the voltage division across  $R_7$  and  $R_8$ . This voltage is fed back directly to  $R_2$ .

refresh your mind—the feedback voltage is out of phase with the incoming signal and is of such nature that it decreases any distortion that is introduced between the point where the feedback occurs and the output. At the same time, the output level is reduced and the plate impedance of the output tube is brought down more nearly to that of the triode. The over-all result of this is that pentode and beam power output tubes can be used with nearly the fidelity obtained from the use of triodes. Although one of the advantages of the pentode and beam power tubes is lost in that the

transformer tap arrangement. Each impedance value represents the impedance between that tap and the "common" terminal. Some amplifiers may have a few less taps and others may have a few more, but in general this is the basic arrangement.

Standard loudspeakers have voice-coil impedances of 4 ohms, 8 ohms, or 16 ohms. There are a few others, but these are the most common. If you are using a single loudspeaker of any of these values, all you need to do is to connect it between the proper taps to provide the desired impedance match to the output stage.

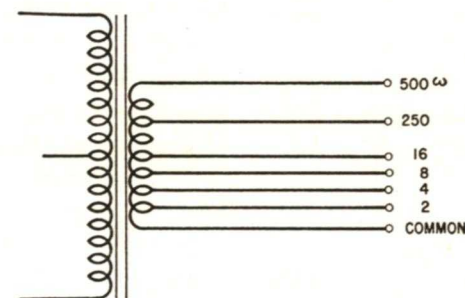

FIG. 14. The taps on a typical output transformer.

power sensitivity is reduced, it is still better than that of triodes.

### LOUDSPEAKER COUPLING

As you know, the ordinary radio receiver commonly has an output transformer designed specifically to match the particular loudspeaker used in the set to the output tube or tubes. In public address work, however, an amplifier may be used with any one of several types of loudspeakers or with a group of loudspeakers, depending on the installation, so the output transformer must have taps to accommodate different voice coil impedances.

Fig. 14 shows a common output

If you are using more than one of these standard loudspeakers, the voice coils may be connected either in series or in parallel to equal some impedance value that the transformer can supply. For example, if you connect two 8-ohm loudspeaker voice coils in parallel, their net impedance will be 4 ohms, so you can use the 4-ohm tap. Connecting the same two 8-ohm loudspeakers in series would give 16 ohms net impedance, and the 16-ohm tap could be used; however, it is more common practice to connect the loudspeakers in parallel so that both will not be cut off if one of them should open or become defective.

Naturally, the more loudspeakers used, the more troublesome becomes the problem of impedance matching. We could connect four 8-ohm loudspeakers in parallel to get a net impedance of 2 ohms, which our transformer is capable of matching. However, connecting three such loudspeakers in parallel would give an impedance of  $8 \div 3$  or 2.6 ohms, for which there is no transformer tap. When an in-between value like this is obtained, it is usually best to use the output transformer tap that is next lower in impedance, because doing so minimizes distortion and loss of power. Therefore, we should use the 2-ohm tap. (As a practical matter, although it is desirable to match within 10%, mismatching up to 25% is tolerable and causes very little power loss.)

Elsewhere, we will go further into this problem to show in more detail some of the difficulties met in coupling loudspeakers to amplifiers.

Returning now to our transformer, you will notice that there are two high-impedance terminals, one rated at 250 ohms and the other at 500 ohms. These are needed because the loudspeakers must frequently be at considerable distances from the amplifier. The loudspeaker voice coils have relatively low impedances, so even if you use rather large, low-resistance wires to connect them to the amplifier, there will still be considerable loss in the wire. For example, if we use No. 20 B & S wire to connect a 4-ohm loudspeaker to an amplifier, we cannot have the loudspeaker farther than twenty-five feet from the amplifier if we are to keep the line loss to a value of 15%. If the loudspeaker

must be placed farther away from the amplifier, or if the power loss is to be kept less than 15%, we would either have to use much larger wire or, preferably, use a higher-impedance line. Such a line will also be discussed elsewhere, but for now let us say that a line will transmit power with a minimum loss if we connect a fairly high impedance to both of its ends. An impedance of 500 ohms is commonly used. With the higher impedance, we can have a higher terminal voltage and a much smaller current for the same power. Since the loss in the line depends upon the  $I^2R$  value, reducing the current for the same power delivery means that the loss is decreased.

Therefore, if we connect one end of a line to the 500-ohm terminals of the output matching transformer, and connect the other end to a transformer that is designed to match 500 ohms to a voice coil, the line becomes relatively loss-free and can be run for considerable distances. For example, the No. 20 wire that we mentioned before, when used as a 500-ohm line, can be run for 1500 feet with a power loss of only 5%. As you recall, such wire has a 15% loss in a 25-foot run when it is used to feed the voice coil directly.

We'll go further into this problem of lines and impedance matching elsewhere. The important thing to know, as far as the amplifier itself is concerned, is that its output transformer has a number of secondary taps with which it is possible to match impedances under most ordinary circumstances.

Amplifiers vary considerably in the physical arrangement of their termi-

nals. Some have them brought out to a terminal strip to which the necessary loudspeaker connections can be

made. In others, they are brought out to sockets into which the loudspeaker cables can be plugged.

## Voltage Amplifier Considerations

### INPUT CONNECTIONS

An amplifier must have enough gain to raise the voltage level from that of the output of the microphone to whatever is required to drive the power output stage so that it will deliver the rated power output. By taking the ratio of these two voltage

Standard practice is to bring the input terminals of the p.a. amplifier to jacks so that the microphones and other devices may be plugged in easily. From these points, the circuit goes to the grid of the first tube. There are three basic input arrangements, all of which are shown in Fig. 17.

Fig. 17A shows a high-impedance input, intended to operate from any high-impedance device such as a crystal phono pickup or crystal microphone. As you will learn in later Lessons, any signal source whose impedance is above, let us say 40,000 ohms is considered to be high impedance and can be fed directly to a tube grid as shown here.

Many microphones and the magnetic phono pickups are relatively low-impedance devices. For example, some dynamic microphones have as low an impedance as have many electrodynamic loudspeaker voice coils.

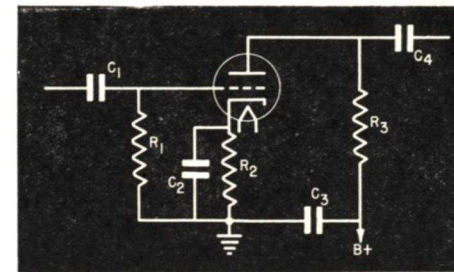

FIG. 15. A typical triode voltage-amplifier stage.

levels, we can determine the gain in decibels needed. From this, we can set up any combination of stages, the product of whose gains equals the necessary gain value. In practically all modern amplifiers, the voltage amplifier stages are resistance coupled and, in general, they duplicate receiver voltage-gain stages in their design. Triodes are commonly used; sometimes pentodes are used also. Figs. 15 and 16 show typical circuits.

The only major differences between p.a. amplifiers lie in the number of stages used and in the special features, such as the input coupling, the methods of mixing signals, and the tone-control network. We shall now take up these special items, leaving complete schematics for later.

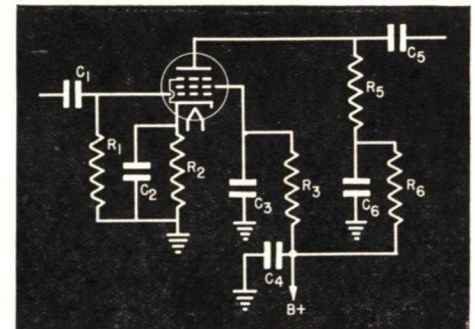

FIG. 16. A voltage-amplifier stage in which a pentode is used.

With devices of this kind, the proper impedance match must be made to the grid of the tube so that there will be sufficient voltage for proper operation. Also, since the microphone may sometimes have to operate at a distance from the amplifier, it is standard practice to use a matching transformer between the microphone or pickup and connecting line, which is almost always rated at 500 ohms. Then, at the amplifier, another transformer is used to match the 500-ohm line to the grid input of the first tube.

There are two basic arrangements for low-impedance inputs, which are shown in Figs. 17B and 17C. To set

a fixed value for the grid input impedance, a resistance of some value around 100,000 ohms may be connected as  $R_2$ . Then, the transformer matches 500 ohms to the resistor value.

Fig. 17B shows what is known as the unbalanced line, in which one side of the line is grounded. The microphone cable used here (and in the high-impedance circuit in Fig. 17A) is a coaxial type consisting of an insulated conductor surrounded by a flexible braided shield, which acts as the other side of the line. In Fig. 17C is shown the balanced line. The basic difference here is that there are two separate conductors and that the ground is made to a center tap at a transformer at each end of the line. These two conductors can be and usually are surrounded by shielding braid that serves as a ground return. The advantage of the balanced system is that both lines will pick up an equal amount of noise or hum voltage and will feed these equal voltages in opposite directions through the input transformer of the receiver so that they will cancel. (The signal current sets up a circulating current throughout the entire system, however, so it is not cancelled.) Therefore, in applications where noise and hum are troublesome, the balanced input is used.

### MIXING AND FADING

One of the important problems in p.a. work is the necessity of operating from more than a single source. Even the simplest of p.a. systems will have at least one microphone and one phonograph pickup, and will ordinarily have provisions for connecting

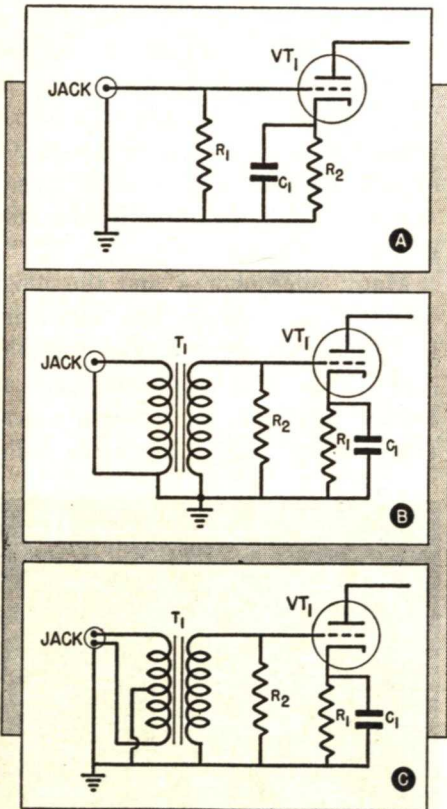

FIG. 17. Three kinds of input circuits. A high-impedance circuit is shown in A, an unbalanced low-impedance circuit in B, and a balanced low-impedance circuit in C.

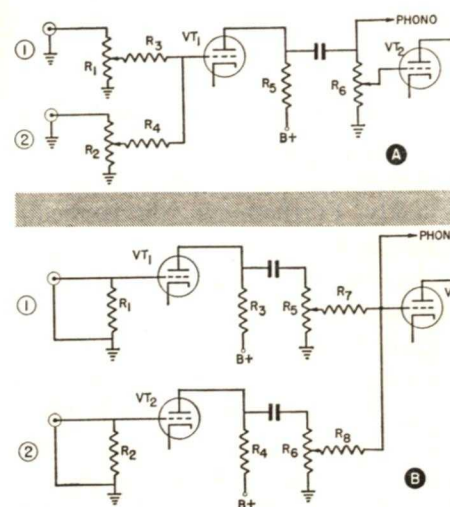

FIG. 18. Two kinds of resistance mixing circuits.

several other devices of these kinds if they are required. In some of the very elaborate systems, there may be anywhere from three to six microphones connected at one time, and there may well be two record players so arranged that it is possible to supply music continuously by fading from one to the other.

We can't just connect several microphones in series or in parallel and feed them all into the grid of a single tube. Besides introducing problems of impedance matching, this would not permit us to have control over each individual input, which is quite necessary. Even when you have a group of microphones picking up the same program, as when you have two or three picking up an orchestra, it is necessary to adjust the level of each microphone individually to get the proper balance between all of the input levels. Then, to have a truly flexible arrangement, it is desirable to be able to turn one microphone off and turn another one on smoothly and simultaneously, without having to unplug a microphone and then plug

another one in its place. And, as we mentioned before, the same is true of record players—when continuous music is desired, it is important to be able to fade out one player and run in another one without any appreciable break in the continuity of the program.

Therefore, p.a. systems have a number of input terminals, each with its own separate control to make it possible to adjust the levels individually. You will find that p.a. amplifiers differ widely in the number of such input channels provided, according to the uses for which they are designed. However, regardless of whether there are two microphone or phono input terminals or six, the following basic facts will apply.

**Resistance Mixing.** Fig. 18 shows two examples of what is known as resistance mixing. In Fig. 18A we have two microphone channels, each feeding into its own individual level control  $R_1$  or  $R_2$ . By adjusting these controls individually, we can adjust the output from the corresponding channel to any desired level. Thus, it is possible to cut one off and the other one on, then to fade from the one that is on to the other one. Or, if desired, they may both be fed in at the same time at some predetermined level. From these controls, the signal goes through preamplifier tube  $VT_1$  and then is resistance coupled to amplifier tube  $VT_2$ .

Potentiometer  $R_6$  acts as a master volume control in that it controls the total signal level. With this form of control, it is possible to preset the mixer control  $R_1$  and  $R_2$  at some desired level and then use the master control to vary the volume as re-

quired. Placing the master volume control after amplifier tube  $VT_1$  is desirable because all controls become noisy with use as poor contacts develop within them. Any noise signal caused by a control at the input of  $VT_1$  will go through the entire amplifier and therefore receive maximum amplification. A similar noise caused by a control located at the input of  $VT_2$  will produce far less noise output from the amplifier, because it will be amplified only by  $VT_2$  and succeeding stages, not by  $VT_1$  as well. In effect, then, placing a control at the input of  $VT_2$  lengthens the life of the control, because it can get much noisier before it has to be replaced.

Going back now to the input: resistors  $R_3$  and  $R_4$  are used to prevent interaction between the two controls as much as possible. If these resistors were not used, and, for example,  $R_1$  were set at zero, the grid of the tube would be grounded; there could then be no input no matter where  $R_2$  was set. With resistors  $R_3$  and  $R_4$  in the circuit, however, the grid cannot be grounded by setting either  $R_1$  or  $R_2$  to zero; as a matter of fact,  $R_3$  and  $R_4$  are so large that adjusting either control throughout its range changes the resistance in the grid circuit very little. As a result, any adjustment of the control in one channel has little effect on the other channel.

The output from a microphone is always much less than that of any standard phonograph-record player. Therefore, there is always an extra triode or pentode preamplifier in the microphone channels. Notice that the phonograph outputs feed directly to the master volume control  $R_6$  in Fig. 18A, whereas  $VT_1$  acts as a preampli-

fier for all the microphone channels.

Although  $R_1$  and  $R_2$  get less use than the master volume control, they will still get noisy in time, and, because of the extra amplification, this noise will become objectionable very quickly. Furthermore, this particular form of resistance mixing always results in signal loss because  $R_3$  and  $R_4$  act as a voltage divider for any input signal. Since the signal is very weak at the grid of the preamplifier tube, very often the arrangement shown in Fig. 18B is used instead. Here, separate preamplifier tubes are used for each microphone channel, with the result that the very weak microphone signal feeds directly to the grid of its preamplifier tube and is boosted in volume at once. Then, each channel feeds into its volume control— $R_5$  for channel 1 and  $R_6$  for channel 2. Resistors  $R_7$  and  $R_8$  are used to prevent too much interaction between these controls, just as  $R_3$  and  $R_4$  are in the circuit in Fig. 18A. Since the channel fader controls are now in the position occupied by the master volume control in Fig. 18A, it is common practice to eliminate the master volume control altogether and to use these fader controls as individual volume controls and as the fader-mixer control.

**Electronic Mixing.** Another input system is shown in Fig. 19A. This system is called "electronic mixing"; it is not the same as the electronic mixing with which you are familiar from your studies of radio, however, because the mixing does not occur in the electron stream of a tube. Separate amplifier tubes are used for each channel, both of which feed into a common-load resistor. This arrange-

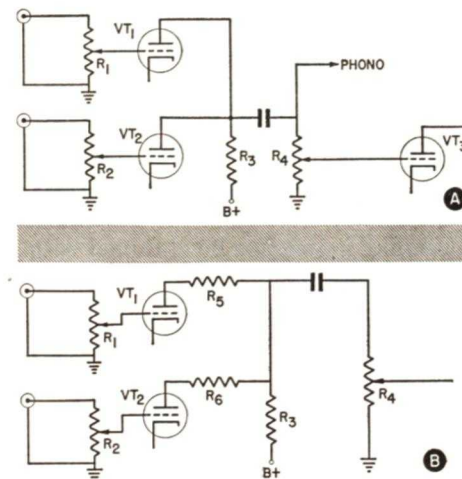

FIG. 19. Two examples of electronic mixing.

ment makes it possible to adjust the input levels to either of the tubes without seriously affecting the other channels. The tubes thus act as decoupling devices that isolate the channels from each other.

Of course, if any channel is overloaded so that the plate resistance of its corresponding preamplifier tube changes, there will be an effect on the other channel, because each tube's plate resistance acts in shunt across load resistor  $R_2$ . This effect can be reduced by the arrangement shown in Fig. 19B, in which resistors  $R_5$  and  $R_6$  have been added to stabilize the two plate resistances. There is no appreciable interaction between the two channels when they are coupled this way.

Of course, this arrangement has the disadvantage of requiring that each channel be controlled at its input by a mixer control. As we mentioned, this is bad from the standpoint of noise production. Therefore, a combination consisting of two preamplifier tubes in each channel is sometimes used (see Fig. 20). Here, we

still have the so-called electronic mixing in that tubes  $VT_3$  and  $VT_4$  feed into a common load resistor  $R_7$ . The controls are now not at the input—tubes  $VT_1$  and  $VT_2$  amplify their corresponding input signals so that the signals will be above any normal noise level produced by the control. A master volume control can be used at the input of  $VT_5$  if desired, but in most cases the fader controls are used as volume controls.

When there are three, four, or more microphone channels, they can be connected in the same manner as two are. Usually all the microphone channels are treated alike.

**Phonograph Channels.** It is necessary to control the outputs of the phonograph-record players just as it is the outputs of microphones. If the system uses a master volume control like those shown in Figs. 18 and 19, it can be used to set the volume level. However, there is usually a separate control in each phonograph channel so that the average level can be set to correspond somewhat with the outputs from the microphone channels. Such a separate control is also necessary if phonograph music is to be used in the background behind programs

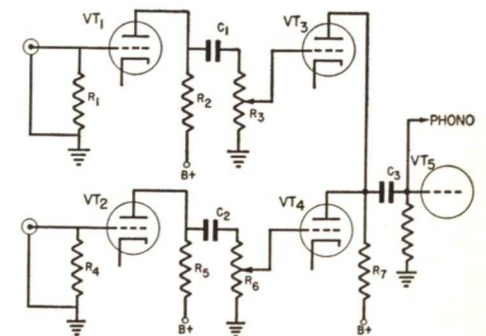

FIG. 20. An improved electronic mixing circuit.



coming through a microphone channel. In such cases, it is necessary to balance the volume levels of the two channels so that they have the desired relative loudness. The master volume control can then be used to regulate the over-all volume.

Ordinarily, when there is more than one phonograph channel, a resistive mixing circuit like the one shown in Fig. 21A is used. As before, resistors  $R_3$  and  $R_4$  are inserted to prevent the controls from having too great an effect on each other.

A special fader control that is

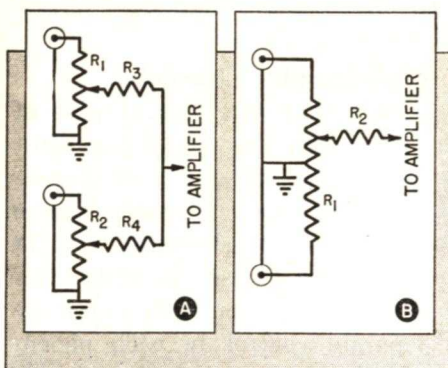

FIG. 21. Two kinds of circuits for phono inputs: a mixing circuit (A) and a fader circuit (B).

sometimes used for two phonograph channels is shown schematically in Fig. 21B. This control has a grounded center tap. As you can see, the output of each channel is applied across half the control. With this arrangement, there is zero output when the slider is set at the center. When the slider is moved toward one end of the control, the output from the channel connected to that half of the control is increased, but the other channel is cut off. If the control arm is moved in the other direction, the output of the other channel is increased and that of the first one is cut off.

This is called a fader control because it is possible to move from maximum volume for one channel down to zero for both and then gradually up to maximum for the other. Such a control has the worthwhile feature that only one hand is necessary to operate it.

Similar fading can be obtained with the controls shown in Fig. 21A, except that two hands must be used, one on each control. Since the operator may at that time have other duties, such as placing the pickup head properly on the record that is just starting, the one-handed control is desirable. However, it has a disadvantage in that you can *only* fade from one channel to the other, you cannot mix them. The control in Fig. 21A permits both record players to be operated at the same time, if this is ever desired.

Resistors  $R_3$  and  $R_4$  in Fig. 21A serve the same purpose they did in Fig. 18A—they prevent the controls from interacting on each other too much. Similarly, resistor  $R_2$  in Fig. 21B acts as a decoupling resistor to prevent the control from grounding the grid circuit to which it connects.

## TONE CONTROLS

Every form of tone control with which you are familiar in radio receivers is used in p.a. equipment. In addition, there are a few types found only in p.a. systems. Most of these involve some type of degeneration. A basic example is shown in Fig. 22. Here, when the switch SW is in position 1, all the a.c. components of the plate current must flow through  $R_1$ . Since the bias for the grid of the tube is developed across this resistor, all a.c. components are fed back equally,

so we have degeneration that is flat with respect to frequency.

When the switch is thrown to position 2, condenser  $C_1$  is connected across  $R_1$ . If condenser  $C_1$  is large enough, its reactance is so small that all audio frequencies are by-passed

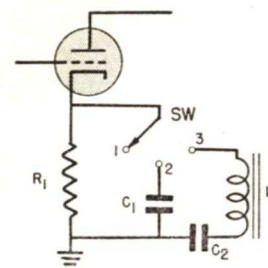

Courtesy Thordarson

FIG. 22. A basic tone-control circuit.

around  $R_1$ , and there is no degeneration at all. However, if this condenser is made rather small, its reactance comes into play. At low frequencies, it becomes a poor shunting path around  $R_1$ , so low frequencies are degenerated. On the other hand, since its reactance drops as frequency increases, it becomes a better by-pass at high frequencies, which are there-

fore not degenerated. Since degeneration reduces the output, this condenser now effectively reduces the bass response, because the bass frequencies are degenerated but the treble frequencies are not.

In position 3, a choke coil is substituted as the shunt across  $R_1$ . The large condenser  $C_2$  is in series with the coil to act as a blocking condenser to prevent it from changing the bias by shunting  $R_1$  by a d.c. path. However, the action is now the opposite to that when  $C_1$  is in the circuit. Now,  $L_1$  offers a low-impedance path for low frequencies, so there is no degeneration at these frequencies. It is a high-impedance path for high frequencies, however, so they are degenerated. Hence, the high-frequency response is reduced when the switch is in position 3.

The actual tone control circuits used are frequently more elaborate than this. We'll see some practical examples when we take up typical diagrams of complete amplifiers.

# Typical P.A. Diagrams

In the following section, we are going to show two typical p.a. amplifiers. We have chosen these diagrams to illustrate some of the circuit ideas we have discussed. Other complete diagrams will be discussed elsewhere.

## LOW-POWER AMPLIFIER

Our first example is shown in Fig. 23. An examination of the power supply shows that it is a standard a.c. type with a transformer, using a full-wave rectifier and a brute-force filter. There is nothing at all remarkable about the power supply.

This particular amplifier has one microphone and one phonograph pickup connection. The microphone connection is of the high-impedance type, since it is arranged to feed directly into the grid of the 6J7 microphone preamplifier tube. The phono pickup is likewise of the high-impedance type and feeds into the grid of the second tube. The potentiometer  $R_1$  acts as a volume control for the phonograph, and  $R_6$  acts as the control for the microphone channel. No master control is used. Since  $R_6$  is to be used as the volume control for the microphone channel, rather than just a level-setting control, it is in the grid circuit of the second tube that you would expect to find the master volume control. This arrangement permits the control to have a longer life, as you have learned, because any noise developed by the control is not amplified as much as is the signal from the microphone.

Resistors  $R_7$  and  $R_8$  are decoupling resistors used to prevent too much

interaction between the two controls. It is possible to blend the phono pickup in with the microphone signal if this is desired.

Whatever the signal source may be, the second (6SJ7) tube acts as the major voltage amplifier. Its output drives the grid of a 6L6 beam-power output tube.

The output transformer has a tapped secondary, the various taps of which are connected to a socket into which the loudspeaker line is plugged. Any of 5 output impedances can be selected by plugging the line into the proper terminals. Since this amplifier delivers only 8 watts, it is generally used to drive a single cone-type loudspeaker, although it can be arranged to drive two small loudspeakers at reduced output.

The output impedance of 4, 8, and 15 ohms provide for direct voice-coil connections, and the line impedance values of 250 and 500 ohms allow a transmission line to be used.

Inverse feedback is used to improve fidelity. The feedback path is from the 250-ohm tap on the secondary of the output transformer through  $R_{15}$  to the cathode of the 6SJ7 voltage amplifier. The inverse feedback voltage is developed across  $R_9$ , which is not by-passed. If the proper output transformer connections are made, this feedback voltage will be out of phase with the applied signal in the cathode circuit; it will therefore reduce the over-all gain but at the same time will reduce even more any distortion developed within the voltage amplifier and output stages.

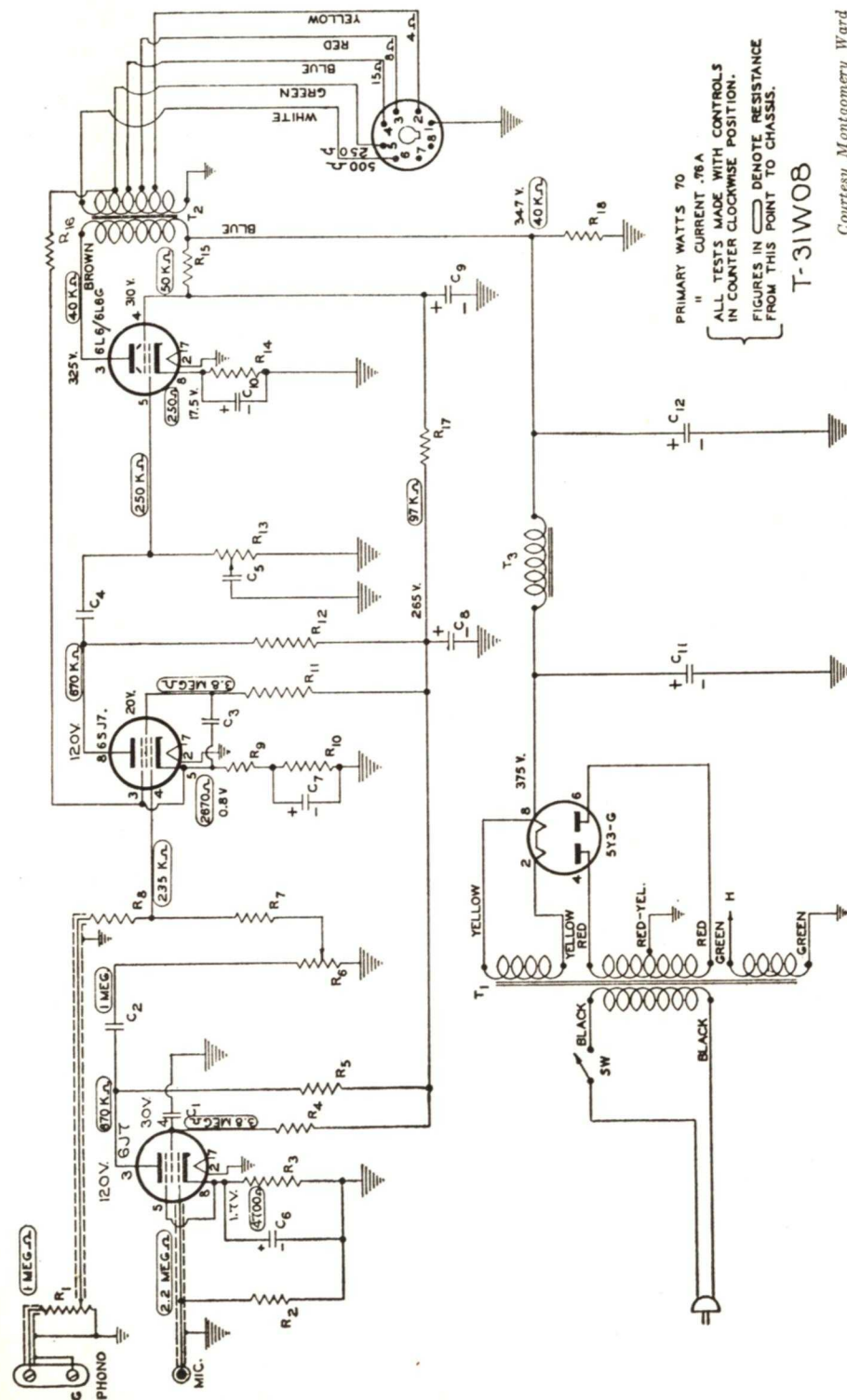

FIG. 23. Schematic diagram of the low-power Thordarson T-31W08 amplifier.

The tone control consists of resistor  $R_{13}$  and condenser  $C_5$ , which is connected to the slider of  $R_{13}$ . As the slider is moved toward the grid end of the control,  $C_5$  becomes more and more of a by-pass, thus reducing the high-frequency response of the amplifier.

### MEDIUM-POWER AMPLIFIER

Fig. 24 shows a medium-power amplifier that has several unique features. There are two microphone inputs, each feeding into its own triode preamplifier.  $R_{11}$  is a gain control for microphone No. 1 and  $R_{10}$  a similar control for microphone No. 2. Notice that these are connected in an unusual manner—they appear to be backward from the way you are used to seeing volume controls. This connection makes it impossible for one gain control to short out the other when it is turned to zero, as you will find by examining the circuit. For example, if the slider on  $R_{11}$  is run up to the top,  $R_{11}$  is shunted by  $R_7$  and by the plate impedance of the preamplifier tube for the No. 1 microphone. Therefore, it is never a complete short circuit. Resistor  $R_7$  is necessary because the plate impedance of the preamplifier tube is not sufficiently large to make it a satisfactory shunt.  $R_9$  is used similarly in series with the slider on  $R_{10}$ .

There are two phonograph terminals, and the phono gain control is of the center-tapped type so that it can act as a fader from one to the other. An additional phono input is connected in parallel with phono input No. 1. However, this is for use with a built-in record player, which may be made a part of the amplifier cabinet.

When this is used, phono input No. 1 is normally not used.

The phono gain control feeds into the grid of the 6SJ7 mixer tube, along with the microphone input. This is a resistance form of mixing, since all the signals are combined at the grid of this tube.

The plate of this tube is resistance-coupled to the control grid of the 6V6 driver tube. This driver tube is a beam-power tube but is connected here as a triode. It still furnishes considerable power through transformer  $T_1$  to the grids of the actual power output tubes, which are two 6L6's connected in push-pull.

The tone control network consists of  $C_6$ ,  $R_{14}$ ,  $R_{16}$ , and  $C_4$ , which are connected in series from the plate to the cathode of the 6SJ7 mixer tube. When the slider on the tone control  $R_{16}$  is at the upward position (at the terminal connected to  $R_{14}$ ), then  $C_6$  and  $R_{14}$  are in series to ground from the plate of this tube. They act as a high-frequency by-pass. At the same time, all the resistance of  $R_{16}$  is in series with  $C_4$ , so this condenser is effectively no longer a by-pass across the cathode resistor  $R_{12}$ . Therefore, complete degeneration occurs, which tends to flatten the over-all response.

When the slider on  $R_{16}$  is moved to the opposite end of the control, the full value of  $R_{16}$  is in series with  $R_{14}$ , and  $C_6$  is no longer an effective by-pass. At the same time, condenser  $C_4$  is connected across  $R_{12}$ . Since  $C_4$  is a fairly small condenser, it is a very poor by-pass at low frequencies, so the low frequencies are still degenerated. It does become an effective by-pass at the high frequencies, however, thus reducing the degeneration at the

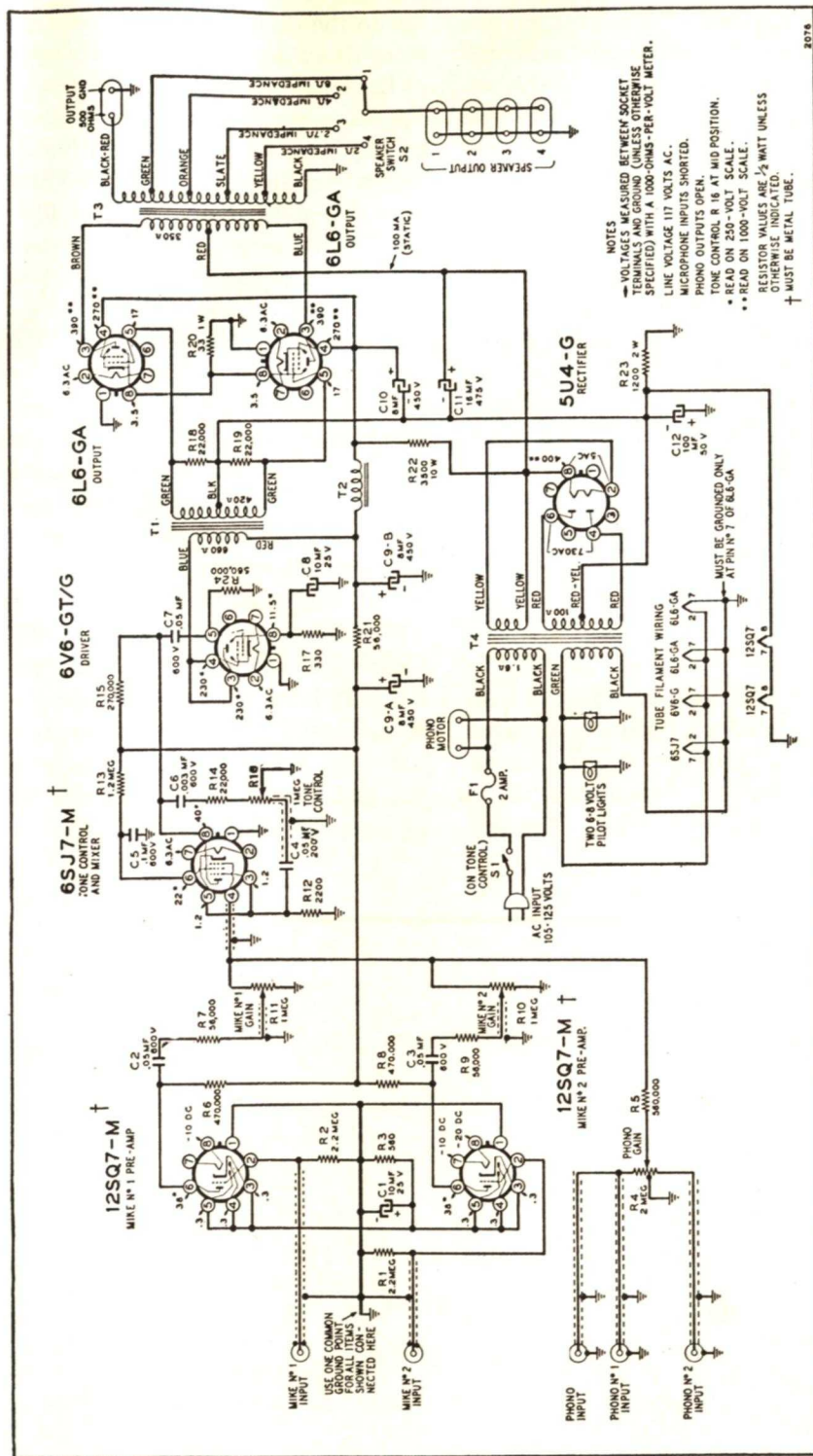

FIG. 24. Schematic diagram of the Airline Model 64BR-7320A, a medium-power portable amplifier.

high frequencies. Therefore, at this end of the control we are favoring the high-frequency response of the amplifier by reducing the effect of  $C_6$  and putting  $C_4$  in the circuit. At the other position, the high frequencies are reduced because  $C_6$  is an effective bypass.

The output transformer has a tapped secondary, the taps of which are connected to a 4-position "speaker switch." Rotation of this switch connects the various taps to 4 paralleled sockets into which the loudspeaker lines are plugged. Thus it is possible to add or remove loudspeakers at will, provided the switch is set to give the proper impedance match. A separate socket is provided for use when a 500-ohm line is to be used.

Examining the power supply, we find that the B power supply is more or less standard. There is a direct connection, with no filtering except for the input filter condenser, to the plates of the output tubes. The sup-

ply to the output tube screen grids is filtered by an R-C filter consisting of  $R_{22}$  and output filter condenser  $C_{10}$ . The plate supply of the 6V6 is filtered by  $R_{22}$  and  $C_{10}$  and is additionally filtered by choke  $T_2$  and  $C_9B$ . Similarly,  $R_{21}$  and  $C_9A$  provide more filtering for the screen grid and plate of the 6SJ7 tube and the plates of the 12SQ7 tubes.

Because the preamplifier provides high gain, great care must be exercised to reduce hum. In this amplifier, the filaments of the 12SQ7 tubes are fed from a d.c. source; they are connected in series across  $R_{23}$ , which is in the B- lead of the power supply. Effectively, therefore, the plate current for all the tubes flows through these two filaments and through  $R_{23}$ . This means that the supply is nearly pure d.c., and is much more hum-free than an a.c. supply would be. Incidentally, the drop across this combination of  $R_{23}$  and the two tube filaments also acts as grid bias for the 6L6 tube.



## YOU HAVE TO WORK

Here is another one of my favorite quotations—this one by Bob Burdette.

“My son, remember you have to work. Whether you handle pick or wheelbarrow or a set of books, digging ditches or editing a newspaper, ringing an auction bell or writing funny things, you must work. Don’t be afraid of killing yourself by overworking. Men die sometimes, but it is because they quit at five p.m. and don’t go home until two a.m. It’s the intervals that kill, my son. The work gives you appetite for your meals; it lends solidity to your slumber; it gives you a perfect appreciation of a holiday. There are men who do not work, but the country is not proud of them. It does not even know their names; it only speaks of them as old So-and-So’s boys. Nobody likes them; the great, busy world doesn’t know they are here. So find out what you want to be and do. Take off your coat and make dust in the world. The busier you are, the less harm you are apt to get into, the sweeter will be your sleep, the brighter your holidays, and the better satisfied the whole world will be with you.”

*J.E. Smith*