

THE INFORMATION  
CONTAINED IN THE  
TECHNICAL MANUAL  
PERTAINS TO THE  
MACHINE BEARING THE  
FOLLOWING SERIAL  
NUMBER

---



## TECHNICAL MANUAL

### 3 DECK

### REPRODUCERS

If You Didn't Get This From My Site,  
Then It Was Stolen From...  
[www.SteamPoweredRadio.Com](http://www.SteamPoweredRadio.Com)

**INTERNATIONAL TAPETRONICS CORPORATION**

2425 South Main Street Bloomington, Illinois 61701 Telephone: 309-828-1381

# ADDENDUM

## ADDENDUM FOR SP, WP, RP, RPD, & 3D

Several changes have been incorporated in ITC cartridge machines to provide enhanced performance and more reliable operation.

### OUTLINE OF IMPROVEMENTS

#### Reproduce Head

A new reproduce head, designed by ITC provides a flatter frequency response, especially in the lower frequencies. Playback frequency response is specified flat + 2 dB from 50 to 15 kHz, but typically is much better than this. The new head, due to its unique construction can last up to 10 times longer than conventional lamination heads. The record head remains a Nortronics Duracore with extended life expectancy.

Ordering information for the new head is as follows:

ITC Part Number	Description
504-0033-000	Head, 2 Track Mono, Reproduce
504-0034-000	Head, 3 Track Stereo, Reproduce

#### Head Mounting Assembly

The head mounting assembly is removable as a unit, maintaining proper alignment. Each adjustment is independent of the other adjustments, and each is lockable. The new head module incorporates a longer azimuth pivot for much finer adjustment. Figure (1) shows an exploded view of the head mounting assembly.

 **INTERNATIONAL TAPETRONICS CORPORATION**  
2425 SOUTH MAIN STREET • BLOOMINGTON, ILLINOIS 61701  
TELEPHONE: 309-828-1381

## Pressure Roller

ITC is now using a pressure roller made from 525K, an advanced rubber compound which exhibits twice the pulling power of ordinary rubber and is not affected by temperature, humidity and all commonly used cleaning substances. The pressure roller also offers five times the life of conventional rollers and increased hardness stability (durometer.) This pressure roller is presently being used in all ITC cartridge machines, and is being shipped as a standard replacement part.

## Cartridge Hold-Down System

The final area of improvement to your ITC unit is a new cartridge hold-down system which provides very precise and repeatable cartridge insertion. This is accomplished by exerting downward pressure on the load-bearing side rails of the cartridge and by applying pressure on the left side of the cartridge to consistently seat it against the right cartridge guide.

## MECHANICAL AND ELECTRICAL ADJUSTMENTS

Some of the following procedures require the use of a tape height gauge. This gauge can be obtained from ITC (part number 830-0022-011). See figure 4 for an illustration of this gauge.

## Cartridge Hold-Down System

Optimum performance from tape cartridges can only occur if the cartridge is positioned accurately and consistently in precisely the same location each time it is inserted into the machine. A means of alignment can be achieved by using a specifically marked cartridge as illustrated in Figure 2. Use a point or scribe and mark the cartridge as shown.

Refer now to Figure 3 in which a cartridge is shown in its properly aligned position. If the alignment cartridge does not position as illustrated, remove the left hand cartridge guide completely and loosen (do not remove) the mounting screws on the right hand cartridge guide. Position the cartridge to the right or left until the scribed lines are located directly over the heads as shown. Be certain that the front edge of the cartridge seats firmly and squarely against the tape guide screws. With the cartridge held securely in this location, position the right hand cartridge guide firmly against the right hand side of the cartridge and then tighten down both cartridge guide mounting screws.

Remove the cartridge and re-insert into the machine forcing it to slide squarely against the right hand guide. Check the alignment again, if it is not exactly positioned, repeat the alignment procedure. It is very important that this alignment is being made as perfectly as possible and that it be consistent in all other cartridge machines. Failure to achieve consistent alignment from machine to machine will create inconsistent tape travel path and thus phase error on stereo machines and azimuth errors on mono.

Mount the left hand cartridge guide as illustrated in Figure 3. A gap of approximately 1/16 inch (1.5 mm) between the edge of the cartridge and the guide is recommended. This will insure correct "seating" of the cartridge each time it is inserted into the machine (an important key to consistent tape travel and alignment).

### Tape Guides

Three independent tape guides are used to provide maximum tape guidance outside of the cartridge. The left tape guide has been specially formed to provide clearance for the cartridge corner post area.

1. Check the positioning of each tape guide by advancing the tape height gauge into the tape guide as shown in Figure 4. The gauge should advance fully into the tape guide without friction, while resting flat on the deck - not tilted as shown by the dashed line (or its opposite) in Figure 4. The tape height gauge must be demagnetized so that it will not affect the heads.
2. If adjustment is required, loosen the two mounting screws.
3. Keeping the tape height gauge flat on the deck, position the tape guide as shown in Figure 4.
  - a. Position the tape guides as close to the head as possible without contacting the head mounting blocks or any parts mounted on these blocks.
  - b. Keep the tape guides vertical. Normally the bottom edge of the tape guide's mounting surface will rest very near the surface of the deck plate.
4. Tighten the tape guide mounting screws and recheck the adjustment.
5. Check and adjust the other tape guides as required. The slot in the tape guide is .249 inch wide (actual tape width is .246, + .002 - .000 inch). The width of this slot can also be properly gauged with the tape height gauge. The arm on the gauge should advance fully into the slot without friction, but there should be no room for noticeable movement of the tool in the slot.

Correctly made adjustments obtained with the tape height gauge will be accurate to less than .001 of an inch.

### Head Height and Zenith

The magnetic tape head nearest the capstan shaft is the reproduce head. The head farthest from the capstan is the record head, except on reproduce only machines. A dummy head is mounted in this position on reproduce only machines in order to maintain constant tension on the tape and thus minimize wow and flutter and improve tape guidance.

The adjustment procedure outlined below should be followed in positioning both the reproduce and record heads. Only height and zenith adjustments are required for a "dummy" head. See Figure 5 for the location of the adjustment screws.

1. Loosen the head adjusting screw lock nut by turning counterclockwise approximately four complete turns.
2. Coarse Height: Adjust the Front Height Set Screw until the top of the upper head track (pole Piece) is 9/16 of an inch above the deck surface.
3. Coarse Zenith: Adjust the Rear Height Set Screw until the face of the head is perpendicular with the surface of the deck. Position the Tape Height Gauge (or any gauge known to be square) on the deck surface and move it against the face of the head as shown in Figure 6. The gauge must be demagnetized before making adjustments. Be careful to avoid scratching the face of the head. When the head is perpendicular, the face of the head and the "square" will be flush.
4. Fine Height and Zenith: This adjustment is made using the tape height gauge.
  - a. Position the gauge in front of the face of the heads as the tape would be positioned if it were being played (Figure 4).
  - b. Alternately adjust the Rear and Front Height Set screws to position the top of the upper head track (pole piece) so that it is even with the upper edge of the gauge, and to position the bottom of the lower head track (pole piece) so that it is even with the lower edge of the gauge. The set screws should be adjusted by equal amounts in the same direction.
  - c. Recheck the zenith of the head instructed in step 3. If adjustment is necessary, height must also be rechecked and adjusted until both height and zenith are perfect.
  - d. Carefully tighten the Front and Rear Height Lock Nuts. Recheck the height and zenith adjustments. If a change has resulted, repeat the Fine Height and Zenith adjustments.

## Mono Azimuth Adjustments

Before attempting these adjustments, insure that the mechanical adjustments of the tape guides and the adjustment of height and zenith of both the Record and Reproduce heads (or Reproduce and "dummy" in Reproduce only machines) are correct.

### 1. Reproduce Head Azimuth Adjustment:

- a. Connect a 600 ohm load to the reproduce amplifier output terminals. Connect a high impedance voltmeter across this load.
- b. Insert a 15 kHz Standard Azimuth Alignment Tape and start the machine.
- c. Adjust the reproduce head azimuth set screw (refer to Figure 5 for location) to produce maximum output level.
- d. Carefully tighten the lock nut observing the voltmeter to insure that no change in output level occurs.

### 2. Record Head Azimuth Adjustment: It is reminded that changes in azimuth to the Master Record head can result in azimuth errors in all the Reproduce machines within a system unless the resultant azimuth is carefully checked against each of these Reproducers. Any change in azimuth of the record head should be attempted ONLY AFTER all mechanical adjustments are carefully checked and the Master Reproduce head is aligned to the 15 kHz Standard Azimuth Alignment Tape as above.

- a. Select an erased 3 1/2 minute cartridge which is known to have consistently good operating characteristics. It is suggested that this cartridge be set aside and used only for recording head adjustments. It thus will become the standard for your operation.
- b. Connect a 600 ohm load to the Reproducer output terminals. Connect a high impedance voltmeter across this load.
- c. Connect an audio oscillator to the recorder input and set it for -10 dBm at 15 kHz.
- d. Start the recorder and adjust the azimuth set screw on the record head to produce maximum output level (See Figure 5).
- e. Carefully tighten the lock nut observing the voltmeter to insure that no change in output level occurs.

## Stereo Azimuth Adjustment

Two track stereo recording-reproducing performance is subject to several contributing mechanical inaccuracies which can cause phase shift in simultaneously monitored reproducer outputs. In stereo systems these phase shifts are generally not perceptible in the final reproduction; however, in cases where monophonic "dubbing" or channel summing is desired, phase shifts can result in serious amplitude variations or drop-outs especially at the higher frequencies. Most common causes of these problems are:

1. Lateral displacement of the pole pieces with respect to each other within the head case.
2. Improper azimuth of the heads with respect to each other (record head to reproduce head on any reproducer in a system).
3. Improper tape guidance (skew) either within the cartridge or through the tape guide system.

International Tapetronics has attempted to provide the best features possible to assist in the proper guidance of tape outside of the cartridge. Three adjustable tape guides, heavy-duty micro-adjustable patented head module, and the use of "dummy" heads in Reproduce only machines, lend to consistent guidance of the tape through the head assembly.

The following tests and adjustments do not preclude the many possible techniques for measuring phase shift, but provide the basis for satisfactory results using a minimum of equipment and skill.

### 1. Master Reproduce Head Azimuth:

- a. Connect 600 ohm loads to both left and right channel outputs. Connect a high impedance voltmeter to the left channel output. Insert a FULL TRACK 1 kHz reference "0" level tape and start the machine. Set the left output gain control for 0 dBm output. Now connect the voltmeter to the right channel output and adjust the right output gain control for 0 dBm output.
- b. Insert a 15 kHz FULL TRACK azimuth alignment tape and carefully adjust the reproduce head azimuth screw for a maximum reading on the voltmeter. Observe the mechanical position of the azimuth screw.
- c. Move the voltmeter to the left channel output. Now move the azimuth screw a small amount in either direction and observe the voltmeter reading as an increasing or decreasing output. Continue moving the screw in the direction that produces increasing output until a maximum reading is obtained.

- d. Observe direction and amount that the screw was turned to obtain maximum reading on the left output with respect to the previous setting for maximum on the other channel. Set the azimuth screw to the midpoint between these settings to obtain AVERAGE azimuth for the two channels.
- e. Connect the horizontal input of a scope so equipped to the right channel output. Insert a FULL TRACK FREQUENCY ALIGNMENT TAPE and start the machine. Adjust the horizontal gain, if provided on the scope to a suitable amplitude. Remove the horizontal input.
- f. Connect the vertical input to the same right channel output and adjust the vertical gain to provide a deflection equal to that of the horizontal above.
- g. Now connect the horizontal input to the left channel output. Run the tape to the 1 kHz section. A pattern such as Figure 7 should now appear. If not, reverse the two leads of the horizontal input. This pattern represents the "0" or near "0" phase shift pattern of the system.
- h. Allow the tape to run to the 4 kHz section and observe if phase shift has occurred. (Refer to Figures 8 through 10.) If phase shift has occurred, adjust the play head azimuth screw to correct this phase shift in the exact reverse rotation to which it has occurred. (This means that if the pattern was increasing clockwise from 0 shift as frequency increased, the azimuth screw should be turned in such a way to cause the scope display to rotate CCW back to the "0" position.)
- i. Now allow the tape to continue through the various frequencies observing the scope display to insure that no 180° reversals occur. At 15 kHz final adjustment of the azimuth screw can be made to provide best average phase shift. It is normal for shift "jitters" of several degrees to occur at the highest frequencies, so setting should be based on best results. It is desirable to run the tape several times, observing that phase reversals do not occur at any frequency. Tighten the azimuth lock nut while observing that no phase changes occur.

## 2. Master Record Head Azimuth:

NOTE: Performance of this procedure assumes that the reproduce alignment procedure has been performed, and that all test equipment is still connected to the unit under test.

- a. Select a 3 1/2 minute cartridge that is known to have consistently good operating characteristics.
- b. Connect an audio oscillator to the recorder input and set it for 1 kHz at -10 dBm.
- c. Start the recorder and adjust the recording head azimuth screw for maximum amplitude of the display on the scope. (The scope gains may be adjusted in equal amounts to increase amplitude of the display if necessary.)



- d. Sweep the oscillator from 1 kHz up to 15 kHz. If a phase shift begins to occur, adjust the azimuth screw to retain the "0" phase shift pattern. When 15 kHz is reached and the azimuth is set, tighten the lock nut while observing that the phase does not change.
3. Other Reproduce Head Azimuth: It is important to realize that all reproducers within a system must be azimuth - aligned to the master recorder. To implement this, it is necessary to prepare a test cartridge recorded on the master recorder each time any adjustment to this recorder is performed. This cartridge is in turn used to align EACH reproducer in the system.

#### Head Replacement

ITC equipment utilizes no-mount type heads to provide quick and easy installation.

1. Loosen the two screws in the head mounting strap. Remove the old head and insert a new one.  
NOTE: The color of the head lead arrangement
3. Align the rear edge of the head case so that it seats squarely against the back of the "step" cast into the head mounting block. See Figure 11.
4. Tighten the screws in the head mounting strap.
5. Reconnect the head cables.

CAUTION: Use care when reconnecting the head cables as the head pins can be broken off if excessive side pressure is exerted against them.

6. Follow the procedures outlined in this SECTION regarding height, zenith and azimuth/phase alignment.

Figure 1

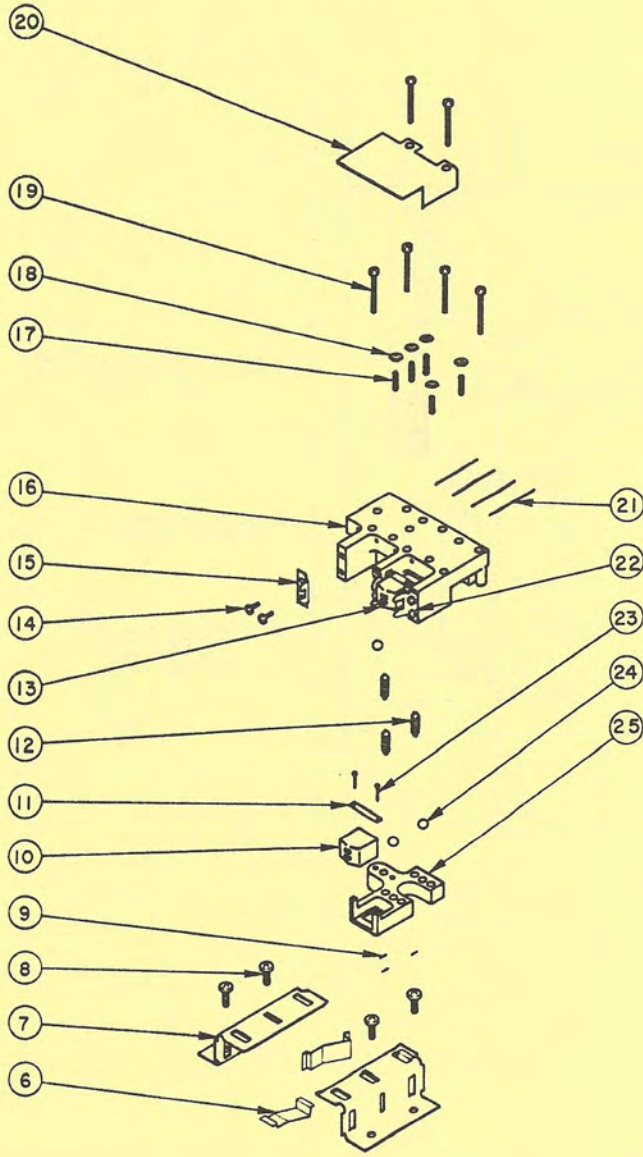

6	301-0045-001	Spring, Cartridge Retaining
7	272-0020-002	Guide, Cartridge
8	350-0604-000	Screw, Phillips Panhead 6-32 x 1/4
9	282-0001-001	Pin, Roll 1/16 x 5/16
10	504-0036-000	Head, Recording - Mono
	504-0037-000	Head, Recording - Stereo
11	303-0001-001	Strap, Head Mounting
12	301-0036-000	Spring, Extension 7/16 x 3/16 O.D.
13	504-0033-000	Head, Reproduce - Mono
	504-0034-000	Head Reproduce - Stereo
14	350-0403-000	Screw, Phillips Panhead 4-40 x 3/16
15	272-0003-001	Guide, Tape L.H.
16	253-0057-003	Block, Head Assembly
17	355-0608-000	Screw, Socket Set 6-32 x 3/8
18	370-0602-000	Nut, Hex 6-32 x 1/4
19	350-0616-000	Screw, Phillips Panhead 6-32 x 1-1/8
20	297-0010-001	Shield, Head Upper
21	282-0034-001	Pin, Head Assembly 1.312 x .093
22	272-0002-002	Guide, Tape R.H. and Center
23	350-0308-000	Screw, Phillips 3-48 x 5/8
24	322-0002-000	Ball, Steel 5/16 Diameter
25	253-0056-002	Block, Head Mounting

Figure 2

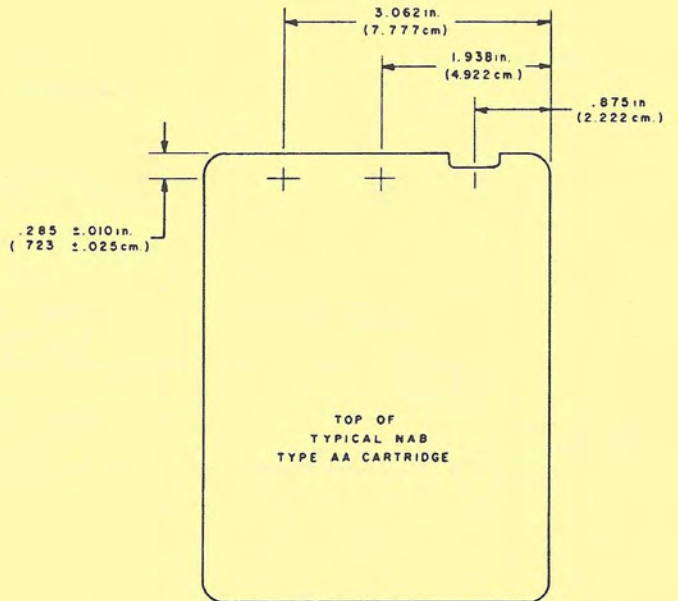

Figure 3

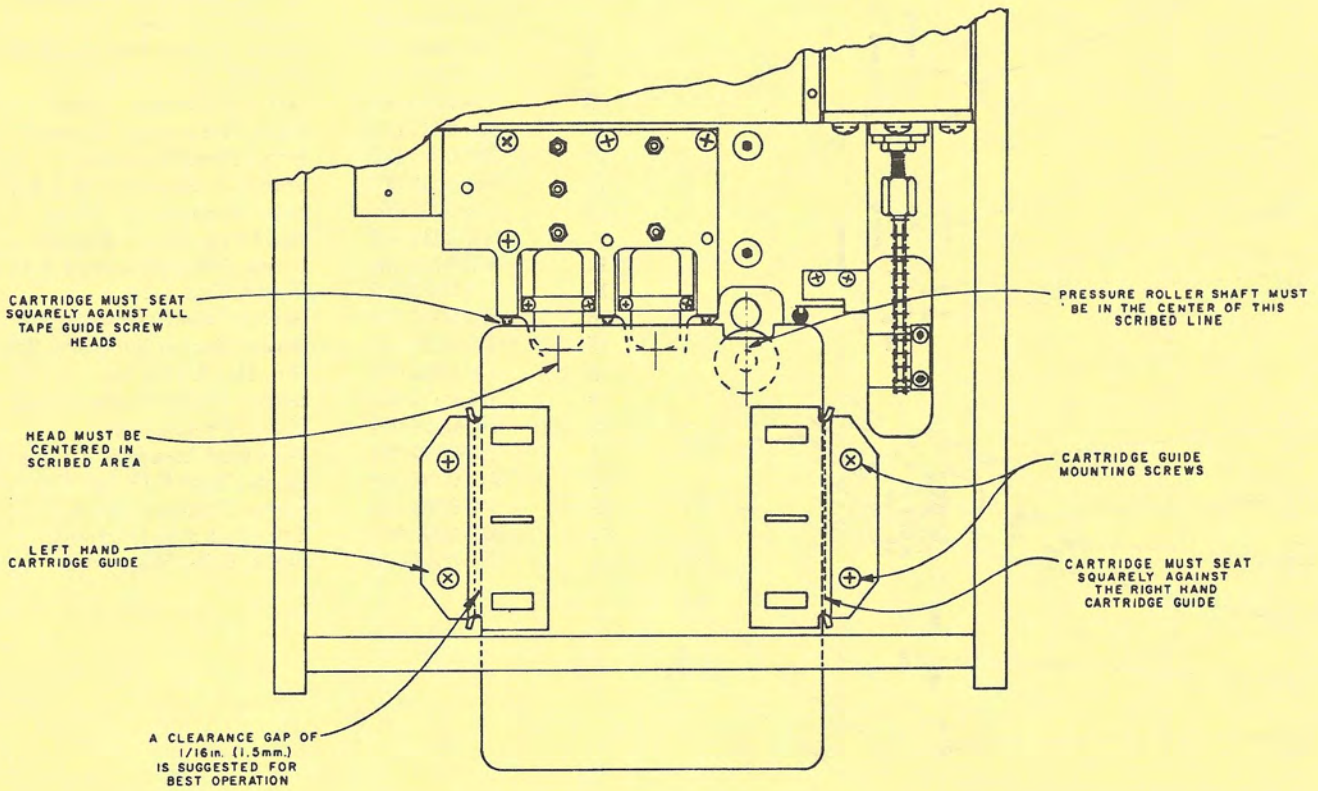

Figure 4

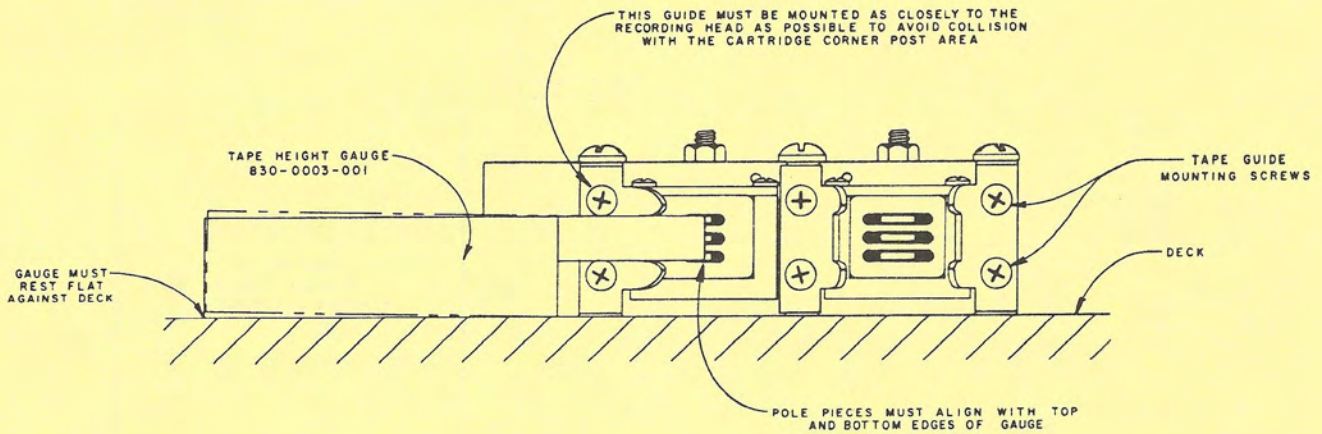

Figure 5

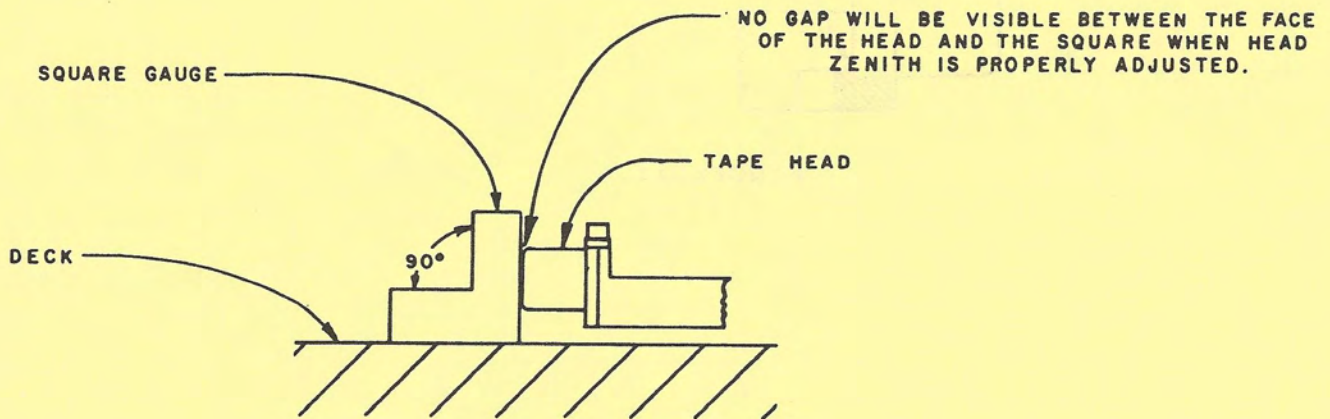
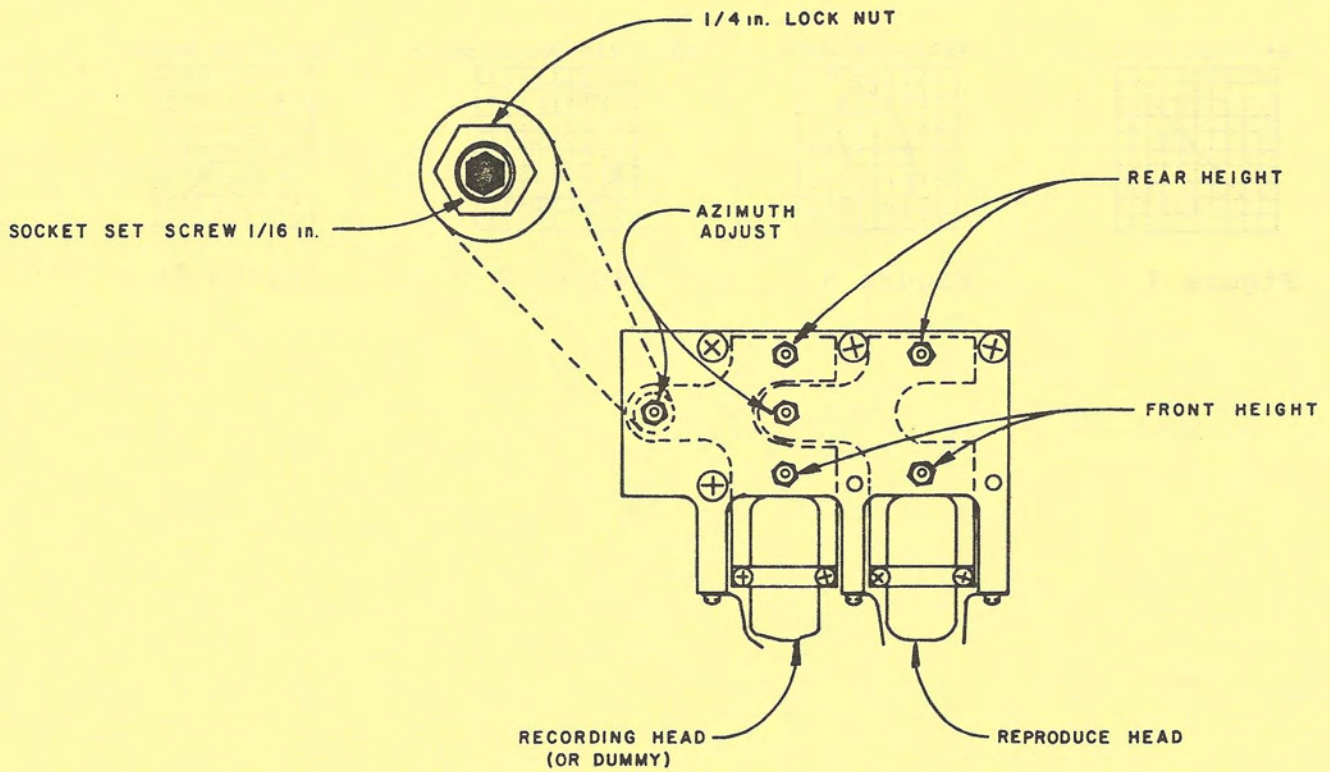

Figure 6

0° PHASE SHIFT

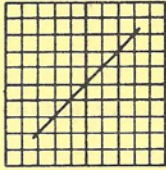

Figure 7

45° PHASE SHIFT

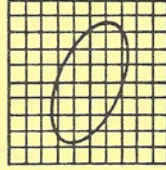

Figure 8

90° or 270° PHASE SHIFT

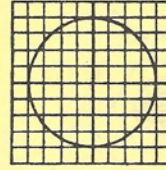

Figure 9

180° PHASE SHIFT

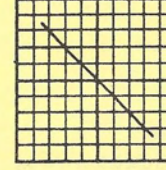

Figure 10

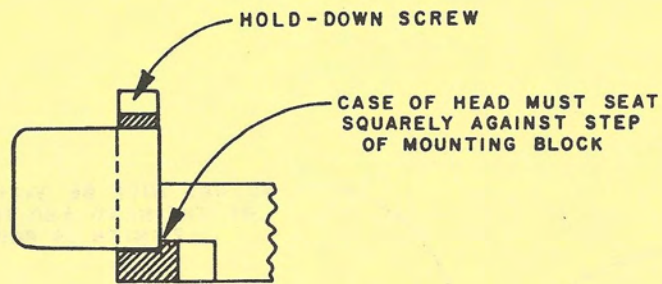

Figure 11

TO: CHIEF ENGINEER

SUBJECT: ITC CARTRIDGE MACHINE GAUGES

REASON: GAUGE UPDATE

ITC has made numerous changes recently regarding gauge usage on it's many models of tape machines. Because of improvements in pressure roller design, we find it advantageous to clarify the use of the appropriate gauges when performing preventative maintenance on your ITC gear.

Due to a change in pressure roller composition in ITC cartridge machines, a minor change has been made in the mechanical adjustments necessary to provide optimum performance regarding the Wow and Flutter specifications. All ITC cartridge machines manufactured after (February 1, 1979) utilize the new pressure roller compound "525-K". This compound is greatly improved over the older rubber rollers you are familiar with in that it is much less hygroscopic - that is, it is not affected by changes in temperature and humidity, which caused the old style rubber rollers to change in size and durometer (compression factor) with changes in weather. It is also immune to most cleaning agents. The result is much more consistant performance, relating to tape skew and phase performance. Mechanically, the new "525-K" rollers will fit your existing ITC cartridge tape equipment. They look exactly like the older rubber rollers, but upon close examination, you will find the new "525-K" rollers to be slightly larger in the overall outside diameter than the old rubber rollers. Because of this, ITC has made minute changes in the setup gauges used in the mechanical adjustment of ITC cartridge tape gear. The procedure used in adjustment of your equipment remains the same as in your technical manuals. The only change is the gauge itself, which is available from ITC. Please refer to the gauge chart at the rear of this bulletin to determine your specific need.

022780/DM

**INTERNATIONAL TAPETRONICS CORPORATION**

2425 SOUTH MAIN STREET • BLOOMINGTON, ILLINOIS 61701

TELEPHONE: 309-828-1381

If You Didn't Get This From My Site,  
Then It Was Stolen From...

[www.SteamPoweredRadio.Com](http://www.SteamPoweredRadio.Com)

ITC is presently shipping cartridge machine pressure rollers made with the new "525-K" compound to customers who purchase pressure rollers as replacement parts. When changing from the old rubber pressure rollers to the new "525-K" compound pressure rollers, mechanical adjustments should be made to your cartridge tape machines to maintain optimum performance. We suggest you develop a method of segregating your "old" supply of pressure rollers from any "new" rollers you may have as spare parts in order to keep the two different pressure roller "compounds" apart when replacement time comes. The "old" rollers are .01" smaller in outside diameter than the 525-K compound pressure rollers.

Gauge number 830-0029 has replaced 830-0006. This is the pressure roller pressure gauge used in ITC Series SP, WP, RP, RPD, 3D, and PD-II cartridge tape machines. The distinguishing difference between the gauges is physical shape: the new gauge has a single step at the end, where the old gauge had two steps. Refer to the pictorial gauge chart at the end of this bulletin for distinguishing differences. Use gauge number 830-0029 when making mechanical adjustments where the new "525-K" compound pressure rollers are in use. Gauge number 830-0006 should be used only when making mechanical adjustments where the old "rubber" pressure roller is in use.

Gauge number 830-0028 has replaced gauge number 830-0007 as the capstan shaft locator gauge. This gauge is used in SP, RPD, WP, RP, 3D, and PD-II cartridge tape machines. The distinguishing difference between the two gauges can be discovered in a simple comparison of physical size. The 830-0028 gauge is approximately 1.6 cm tall, while the 830-0007 gauge is approximately 1.8 cm tall. The 830-0028 gauge is also slightly larger in diameter, and can be "felt" if the two gauges are held end to end. The actual difference in diameter can be measured with a micrometer. Use gauge number 830-0028 in place of gauge number 830-0007 when the new "525-K" compound pressure rollers are in use.

Gauge number 830-0022 replaces gauge number 830-0003. This gauge is for adjusting head height in the SP, WP, RP, 3D, PD-II and Series 99 cartridge tape machines. It is similar to the old number 830-0003 gauge, except that we have cut an extra "notch" at the rear of the gauge to facilitate its fitting into the more compactly designed tape decks such as the 3D. These two gauges may be used interchangeably where space is not a limiting factor. Please refer to Fig. 1 for physical differences.

Gauge number 830-0027 is new, and is used as the capstan shaft locator gauge on ITC Series 99 cartridge tape machines. Please refer to your Series 99 Technical Manual for instructions on its use.

The new ITC gauge numbers are listed below, in chart form. These new gauge numbers are for your convenience in ordering the appropriate gauges necessary for your particular needs. If you have any questions regarding gauge usage, or wish to order them, call ITC Technical Service at (309) 828-1381, or write to:

International Tapetronics Corporation  
 2425 S. Main Street  
 P.O. Box 241  
 Bloomington, Illinois 61701

CARTRIDGE MACHINE GAUGES - USER INFORMATION

Description and ITC Part Number	SP-WP-RP-RPD	3-D	PD-II	Series 99	Description and ITC Part Number
Capstan Shaft Locator 830-0027				X	Capstan Shaft Locator 830-0027
Capstan Shaft Locator 830-0028	X	X	X		Capstan Shaft Locator 830-0028
Pressure Roller Pressure 830-0029	X	X	X		Pressure Roller Pressure 830-0029
Head Height 830-0022	X	X	X	X	Head Height 830-0022



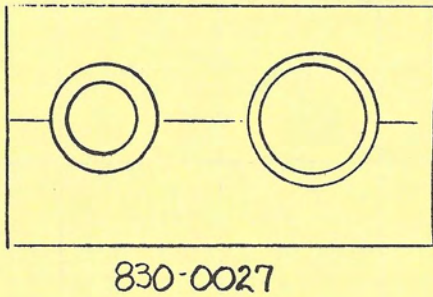
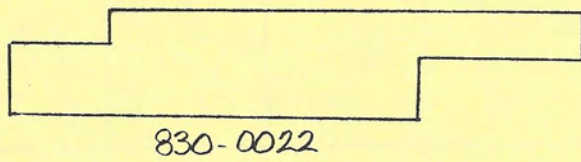
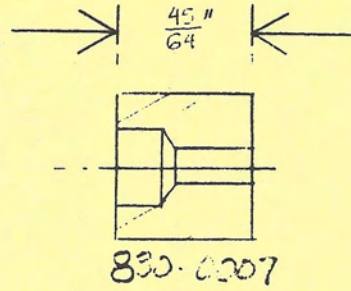
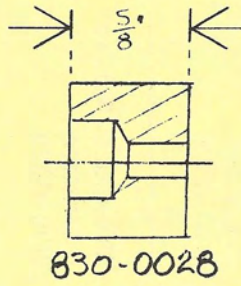
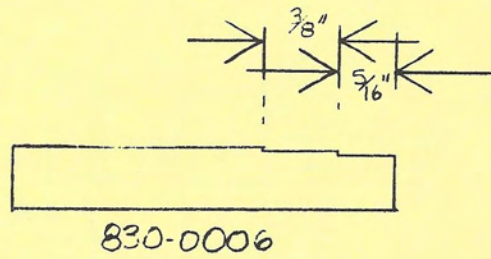
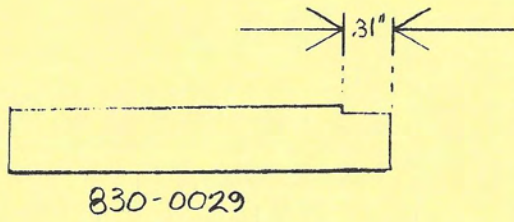

**PROGRAM REPRODUCE AMPLIFIER  
FOR  
SP, WP, RP, RPD, & 3D MACHINES**

**831-0094-003 (Mono)  
831-0094-013 (Stereo)**

### General Description

The Program Reproduce Amplifier shown in the Technical Manual has been replaced with a new amplifier circuit bearing ITC part number 831-0094-003 (mono) or 831-0094-013 (stereo). The new amplifier offers improved sonic performance, passive squelching and increased reliability.

All interconnect wiring to the 831-0094 printed circuit board (via J4) remains as represented in the Technical Manual. However, one jumper wire has been added from the Program Reproduce Amplifier edge connector, J4, Pin 3 to the Detector card edge connector, J5, Pin 5. This jumper supplies 24 volts to the squelch devices (LDR 101 and LDR 102) on the Program Reproduce Amplifier P.C. card.

### Circuit Description

The 831-0094-003 (mono) and 831-0094-013 (stereo) Program Reproduce Amplifiers are provided to amplify and contour the signal supplied by the reproduce tape head.

On stereo units the Left Channel and Right Channel are identical. Therefore, the description on the following page references components in the Left Channel Only.



**INTERNATIONAL TAPETRONICS CORPORATION**

2425 SOUTH MAIN STREET • BLOOMINGTON, ILLINOIS 61701

TELEPHONE: 309-828-1381

## Circuit Description (continued)

The input signal is coupled from the reproduce tape head to the first stage via coupling capacitor C102. Transistors Q101 and Q102 serve as a pre-amplifier which is stabilized to prevent performance variations. DC Feedback is supplied to the base of Q101 from the emitter of Q102 via R101, R107, and R108. AC feedback from the collector of Q102 to the emitter of Q101 (C105, R105, and R104) determines the frequency response of the amplifier. Variable "equalization" is provided by potentiometer R105. C103 and C104 are included for high frequency (RF) rejection.

The output of the pre-amplifier is AC coupled (C107) to the Light Dependent Resistor, LDR 101, which functions as a squelching device. LDR 101 and R113 form a signal voltage divider circuit. The resistance of LDR 101 is controlled by the internal lamp element's brilliance. In this application, the lamp is either fully "on" or "off" as determined by relay K1. With the deck in the run mode, a ground path is supplied to LDR 101 via contacts 6 and 10 of relay K1. Hence, the resistance element of LDR 101 exhibits minimum resistance and the potential across R113 is at its maximum value.

Signal from R113 is again AC coupled (C108) to the base of Q103, a common emitter amplifier stage, with the biasing resistor, R114, connected between the collector and base for DC and temperature stability. The collector output of Q103 is AC coupled (C109) to the base of driver transistor Q104. Q104 supplies drive current for complimentary amplifiers Q105 and Q106. Transistors Q104, Q105, and Q106 are direct coupled with local feedback provided by R119. The output stage (Q105 and Q106) is AC coupled (C111) to Pin 2 of J4.

PARTS LIST

831-0094-003 (Mono)  
831-0094-013 (Stereo)

<u>Component</u> (LC-RC)	<u>ITC Part Number</u>	<u>Description</u>
R101, R129	630-0311-000	Resistor, 100K ohm 1/2 watt 5%
R102, R125	630-0303-000	Resistor, 47K ohm 1/2 watt 5%
R103, R126	630-0247-000	Resistor, 220 ohm 1/2 watt 5%
R104, R127	630-0269-000	Resistor, 1.8K ohm 1/2 watt 5%
R105, R128	636-0002-000	Potentiometer, 10K ohm 1/4 watt
R113, R137	"	"
R106, R130	630-0271-000	Resistor, 2.2K ohm 1/2 watt 5%
R117, R141	"	"
R121, R145	"	"
R107, R131	630-0251-000	Resistor, 330 ohm 1/2 watt 5%
R118, R142	"	"
R108, R132	630-0267-000	Resistor, 1.5K ohm 1/2 watt 5%
R109, R133	630-0255-000	Resistor, 470 ohm 1/2 watt 5%
R110, R134	630-0285-000	Resistor, 8.2K ohm 1/2 watt 5%
R111, R135	630-0295-000	Resistor, 22K ohm 1/2 watt 5%
R120, R144	"	"
R112, R136	630-0258-000	Resistor, 620 ohm 1/2 watt 5%
R114, R138	630-0307-000	Resistor, 68K ohm 1/2 watt 5%
R115, R139	630-0287-000	Resistor, 10K ohm 1/2 watt 5%
R116, R140	"	"
R119, R143	630-0315-000	Resistor, 150K ohm 1/2 watt 5%
R122, R146	630-0252-000	Resistor, 360 ohm 1/2 watt 5%
R123, R147	630-0231-000	Resistor, 47 ohm 1/2 watt 5%
R124, R148	630-0223-000	Resistor, 22 ohm 1/2 watt 5%
C101, C112	696-0124-000	Capacitor, Electrolytic 100MFD, 25V
C102, C113	696-0114-000	Capacitor, Electrolytic 5MFD, 25V
C107, C118	"	"
C108, C119	"	"
C103, C114	677-0001-000	Capacitor, Silver Mica 100PFD 300V
C104, C115	"	"
C105, C116	681-0048-000	Capacitor, Paper .015 MFD 200V
C106, C117	696-0078-000	Capacitor, Electrolytic 100 MFD 12V
C109, C120	694-0003-000	Capacitor, Tantalum 4.7 MFD 35V
C110, C121	694-0007-000	Capacitor, Tantalum 47 MFD 20V
C111, C122	696-0201-000	Capacitor, Electrolytic 220 MFD 25V
C123, C124	681-0050-000	Capacitor, Paper .022 MFD 200V

PARTS LIST (cont.)

<u>Component</u>	<u>ITC Part Number</u>	<u>Description</u>
Q101, Q107	590-0013-000	Transistor, 2N5089
Q102, Q108	"	"
Q103, Q109	590-0017-000	Transistor, 2N5816
Q104, Q110	"	"
Q105, Q111	"	"
Q106, Q112	590-0018-000	Transistor, 2N5817
LDR101	650-0003-000	LDR, Sigma, 301-T1-12B1
LDR102	"	"

Miscellaneous Parts

(3/6)	282-0002-000	Pin, Terminal, P.C.
(1)	325-0094-003	P.C. Card, Mono
(1)	325-0094-013	P.C. Card, Stereo
(12)	613-0001-000	Socket, Transistor

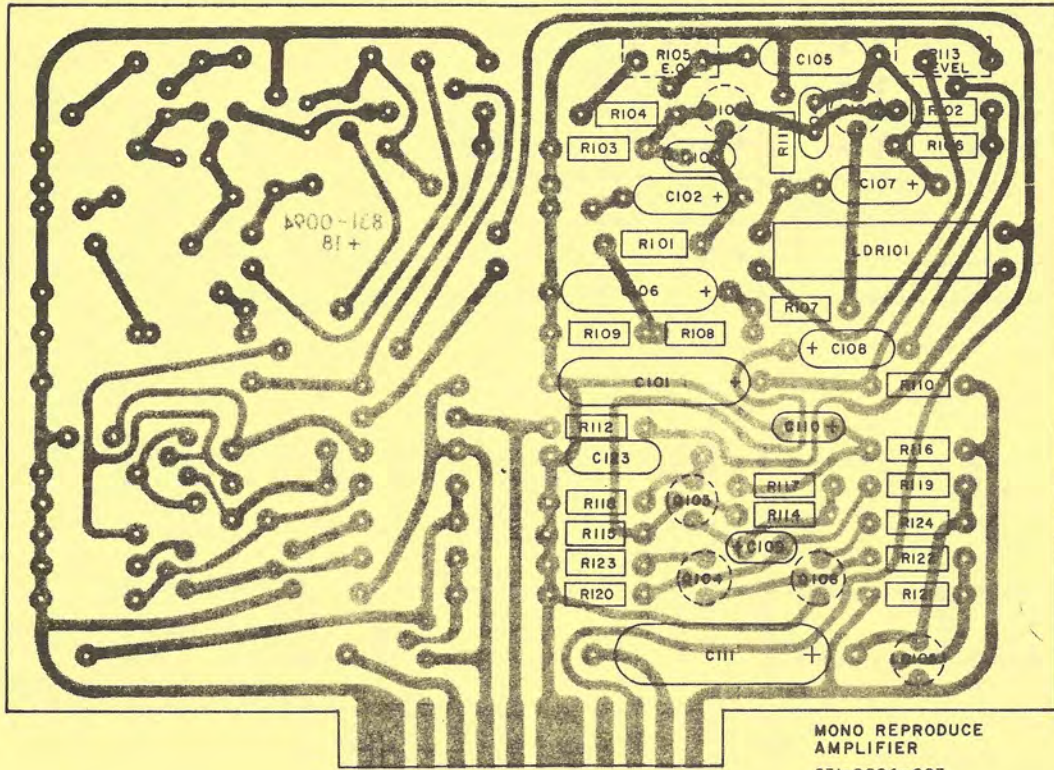

MONO REPRODUCE  
AMPLIFIER  
831-0094-003

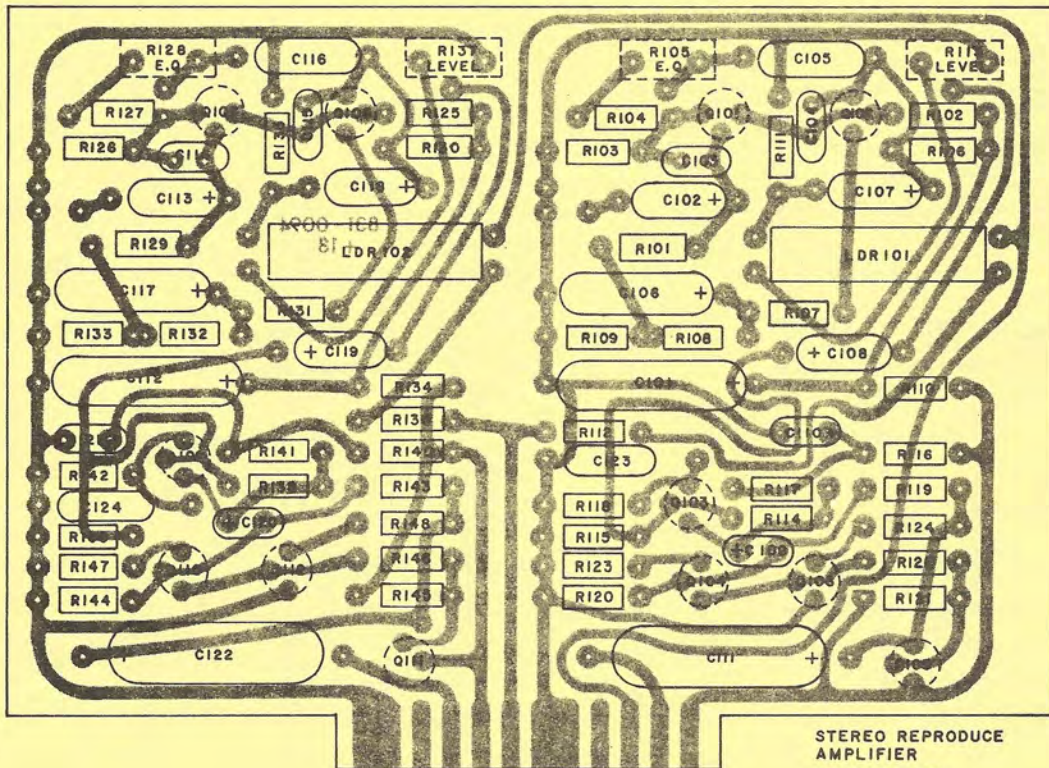

STEREO REPRODUCE  
AMPLIFIER  
831-0094-013

If You Didn't Get This From My Site,  
Then It Was Stolen From...

[www.SteamPoweredRadio.Com](http://www.SteamPoweredRadio.Com)

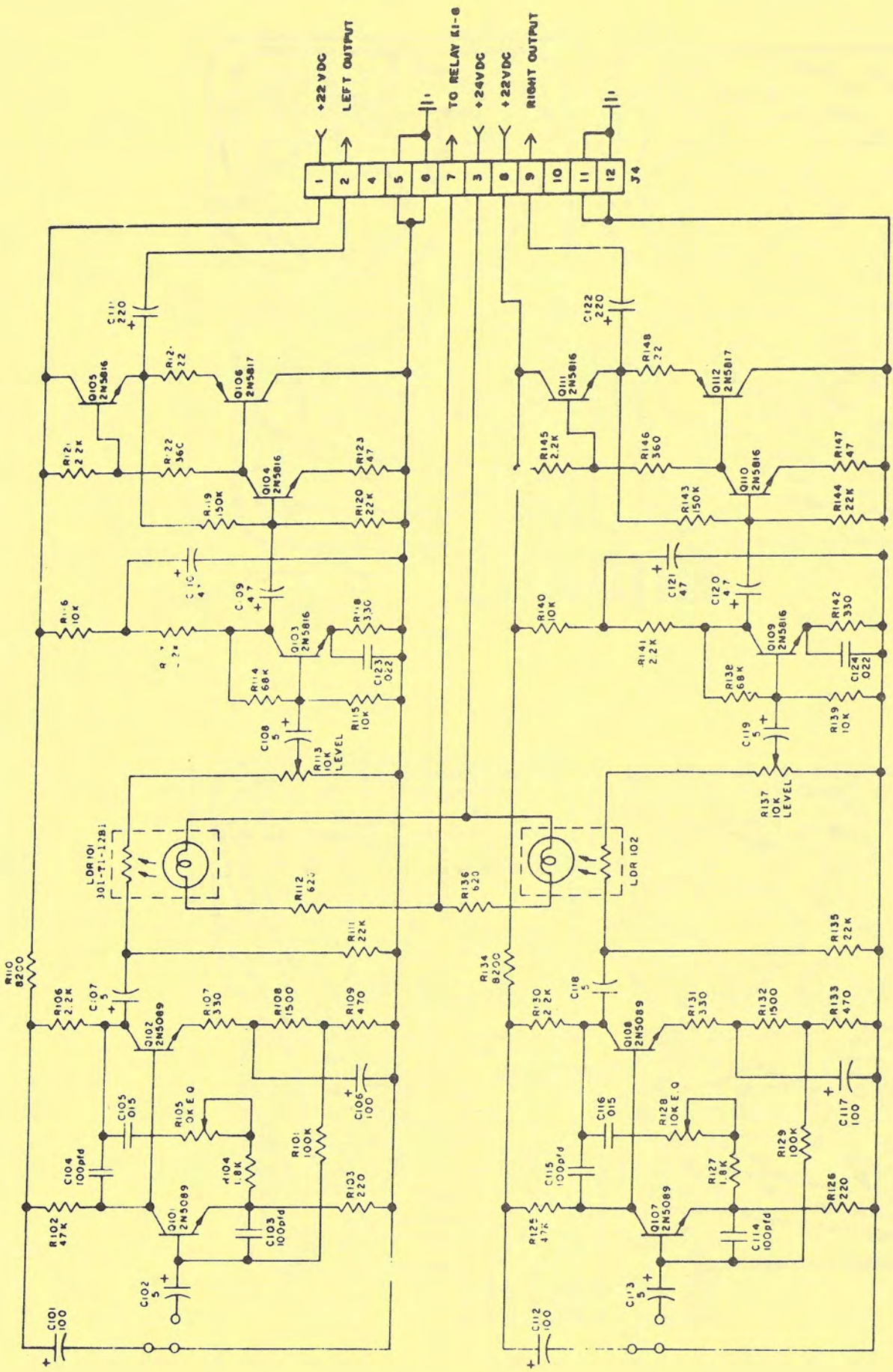

TITLE SCHEMATIC - SP, WP, 30  
 +18dBm REPRODUCE AMP.  
 INTERNATIONAL  
 TAPETRONICS  
 CORPORATION  
 893-0064-003  
 DALLAS, TEXAS 75243

If You Didn't Get This From My Site,  
 Then It Was Stolen From...

www.SteamPoweredRadio.Com

TO: All ITC Customers  
(Please forward to Engineering Department)

RE: Returned Equipment and Components Policy

Dear Chief Engineer:

ITC's objective is to offer the best possible service to our customers. This objective carries through to any equipment that is returned for service--whether it's under warranty or being charged to the customer. Occasionally, however, we've found that our ability to provide this high caliber of service is hampered by our receipt of assemblies and machines without the customer's prior contact with ITC. Special procedures have been developed to allow expedient repair of customer returned items. However, our system only works when we have been notified by the customer that an item will be returned.

Here's how you can help:

1. If a problem is encountered with an ITC machine, call our Technical Service Department collect, at 309-828-1381. Most often, the problem can be diagnosed over the telephone and the necessary replacement part(s) can be shipped. . .often the same day. In most cases, this is the fastest and least expensive method of making the repair for both the customer and ITC.
2. If the problem can't be remedied via telephone conversations, ITC will gladly repair the defective item and return it to you. All we require is notification from you that the item will be returned.

082978LC

810-0008-000

**INTERNATIONAL TAPETRONICS CORPORATION**

2425 SOUTH MAIN STREET • BLOOMINGTON, ILLINOIS 61701

TELEPHONE: 309-828-1381



3. When returning an item or machine for repair, please take a moment to:
  - A. Write a note and describe the problem as fully as possible.
  - B. Be sure to include on the list your name, call letters or company name, and phone number.
4. Package the item securely! Often we receive items that have sustained shipping damage. Occasionally, the damage is sufficiently extensive as to prohibit repair. ITC is not liable for shipping damage. Also, we strongly recommend that complete machines be returned in their original packing material. If you don't have the proper shipping materials, ITC can supply them. It takes longer but it is better to be safe than sorry. Remember--you are responsible for shipping damage.
5. Return the machine with prepaid shipping via your choice of transportation. If necessary, ITC will offer suggestions on methods of shipment.
6. It is an excellent idea to insure the parcel. Declared value can be obtained from the appropriate ITC price list.

It is our sincere hope that you will assist us in this matter. When an item is returned without our prior knowledge, every customer suffers.

Thank you for your cooperation.

**TECHNICAL MANUAL**

**(890-0004-000)**

**3D (THREE DECK) SERIES REPRODUCERS:**

**MONO, SINGLE TONE 827-0001-000**

**STEREO, SINGLE TONE 827-0002-000**

**MONO, TRIPLE TONE 827-0003-000**

**STEREO, TRIPLE TONE 827-0004-000**

# TECHNICAL MANUAL

## TABLE OF CONTENTS

## 3D SERIES REPRODUCER

	Page
<b>SECTION I INTRODUCTION</b>	
A. GENERAL DESCRIPTION . . . . .	1-1
B. SPECIFICATIONS . . . . .	1-3
<b>SECTION II INSTALLATION AND OPERATION</b>	2-1
A. UNPACKING . . . . .	2-1
B. INSTALLATION . . . . .	2-1
C. EXTERNAL CONNECTIONS — AUDIO . . . . .	2-1
D. EXTERNAL CONNECTIONS — CONTROL . . . . .	2-1
E. CONTROL SWITCHES AND INDICATORS . . . . .	2-1
F. OPERATING PROCEDURES . . . . .	2-2
<b>SECTION III PRINCIPLES OF MECHANICAL OPERATION</b>	3-1
A. HEAD ASSEMBLY . . . . .	3-1
B. CAPSTAN DRIVE . . . . .	3-1
C. PRESSURE ROLLER LINKAGE . . . . .	3-1
<b>SECTION IV MECHANICAL ADJUSTMENTS</b>	4-1
A. GENERAL MECHANICAL INFORMATION . . . . .	4-1
B. DECK REMOVAL . . . . .	4-1
C. CAPSTAN SHAFT (MOTOR) POSITION . . . . .	4-1
D. PRESSURE ROLLER/CAPSTAN PRESSURE — COARSE SOLENOID ADJUSTMENT . . . . .	4-2
E. PRESSURE ROLLER/CAPSTAN PRESSURE — FINE SOLENOID ADJUSTMENT . . . . .	4-2
F. SOLENOID DAMPING . . . . .	4-3
G. RIGHT CARTRIDGE GUIDE . . . . .	4-3
H. LEFT CARTRIDGE GUIDE . . . . .	4-3
I. TAPE GUIDE ADJUSTMENT . . . . .	4-3
J. HEAD HEIGHT ADJUSTMENT . . . . .	4-4
K. HEAD AZIMUTH ADJUSTMENT . . . . .	4-4
L. HEAD REPLACEMENT . . . . .	4-5
<b>SECTION V MECHANICAL DRAWINGS</b>	5-1
<b>SECTION VI MECHANICAL PARTS LIST</b>	6-1
<b>SECTION VII PRINCIPLES OF ELECTRICAL OPERATION</b>	7-1
A. GENERAL INFORMATION . . . . .	7-1
B. SOLENOID POWER SUPPLIES . . . . .	7-1
C. LOW VOLTAGE POWER SUPPLY . . . . .	7-1
D. CONTROL CIRCUITRY . . . . .	7-1
E. CUE CIRCUITRY . . . . .	7-2
F. PROGRAM CIRCUITRY . . . . .	7-2
<b>SECTION VIII ELECTRICAL ADJUSTMENTS</b>	8-1
A. CONTROLS . . . . .	8-1

<b>SECTION IX</b>	<b>TEST CARTRIDGES</b>	9-1
A.	PREVENTIVE MAINTENANCE .....	9-1
B.	TEST CARTRIDGES .....	9-1
C.	USE OF TEST CARTRIDGES .....	9-1
<b>SECTION X</b>	<b>ELECTRICAL DRAWINGS</b>	10-1
<b>SECTION XI</b>	<b>ELECTRICAL PARTS LIST</b>	11-1, 2, 3
<b>SECTION XII</b>	<b>MAINTENANCE SCHEDULE</b>	12-1
A.	GENERAL .....	12-1
B.	MECHANICAL MAINTENANCE .....	12-1
C.	ELECTRICAL MAINTENANCE.....	12-1
<b>SECTION XIII</b>	<b>WARRANTY</b>	13-1
<b>SECTION XIV</b>	<b>SCHEMATICS</b>	

## SECTION I

### INTRODUCTION

### 3D SERIES REPRODUCER

#### A. GENERAL DESCRIPTION

International Tapetronics magnetic cartridge Reproducers are designed to meet or exceed the NAB standards for cartridge tape recording and reproducing. The 3D (Three Deck) series reproducers are available in monophonic or stereophonic configurations. All reproducers are furnished with primary (1 kHz) cue capabilities while the secondary (150 Hz) and tertiary (8 kHz) cue detectors are optional.

The top two decks are designed to function as independent reproducers. The bottom deck may be used as a reproducer or, with a WRA series Recording Amplifier, as a Master Recorder/Reproducer. All decks accept the NAB type A and B cartridges.

The electronic circuits are constructed on printed circuit cards and, with the exception of the Utility card, are of plug-in design. Silicon semiconductors are used throughout. The regulated power supply is an integrated circuit in a plug-in TO-3 case. The program amplifiers have NAB equalization and transformer coupled outputs.

The cue tone detectors utilize reliable L-C networks and provide relay contact output information. Upon the conclusion of the audio, the Reproducer continues to advance the tape until a 1 kHz primary cue tone is detected, whereupon the 1 kHz cue detector stops the tape drive mechanism.

The Secondary Cue Tone (150 Hz) Detector, when the machine is so equipped, can be used for such functions as the indication of the "end-of-message." This is necessary in automated systems to start the next deck or machine and can be useful in live operations to keep the operator "on cue" for inserts, tags, or the beginning of the next material. The presence of the secondary cue tone is indicated by the brightening of the front panel and remote "Run" (Start) Lamps.

The Tertiary Cue Tone (8 kHz) Detector, also optional, can be used to supply digital information in automated systems or for auxiliary switching such as the control of slide projectors in television. Presence of the tertiary cue tone is indicated by the illumination of the front panel and remote "Ready" Lamps.

#### B. SPECIFICATIONS

Power: 117 volts AC, 60 Hz, 144 watts; other voltage and frequency variations are available on special order.

The full-swing pressure roller is connected to the actuating solenoid by a simple and reliable chain linkage with a clevis screw adjustment for pressure roller capstan pressure. Air damping of the solenoid is adjustable with a needle valve. The direct-capstan, 450 RPM (375 RPM in 50 Hz models), hysteresis synchronous drive motor (with an electrolyzed shaft) provides optimum tape drive.

Routine servicing requires a minimum of disassembly. Removal of the cover grille provides accessibility to both mechanics and electronics. The top two decks readily slide from the housing after the head leads and solenoid cables are unplugged. Either or both of the top two decks may be removed for service without affecting the remaining decks.

Cue and program cards are easily removed from the rear of the chassis. A single extender card, optionally available, provides a means for mounting each card for circuit analysis. Level controls are located on the circuit cards and are accessible from the rear.

Remote connections make use of latching plugs and sockets to prevent accidental loss of contact. Full remote control and audio output information are readily available on the sockets for each deck. Wiring and an interconnect socket are provided for the optional addition of the WRA Series Recording Amplifier.

The head and track configuration of the ITC Three Deck Reproducer is in accordance with the NAB Standards.

The magnetic tape head nearest the capstan shaft is head A, the reproducing head. Head B is a "dummy" which is installed to maintain constant tension on the tape and minimize wow and flutter. Head B of Deck C is a recording head when the Reproducer is connected to a WRA Series Recording Amplifier.

On mono machines, the upper track is the program channel and the lower track is the cue channel. On stereo units, the upper track is the left program channel, the center track is the right program channel, and the lower track is the cue channel. A graphic comparison of the mono and stereo track configuration is shown in Figure 5-17.

Tape Speed:	7½ inches per second; direct drive, hysteresis-synchronous, common-capstan motor with electrolyzed shaft and instrument-type, permanently lubricated ball bearings.
Wow and Flutter:	0.2% or less
Timing Accuracy:	0.1% or better
Audio Output:	+12 dBm before clipping; normally +4 dBm; 600 ohms balanced. May be strapped for 150 ohms. Independent output for each deck.
Distortion:	2% or less, record to playback at 0 VU record level, 400 Hz.
Noise:	55 dB or better below reference of 400 Hz at 3% THD, monophonic, 50 dB or better below reference of 400 Hz at 3% THD, stereophonic.
Cross Talk Between Channels:	Better than 50 dB at 1 kHz.
Frequency Response:	± 2 dB from 50 to 15,000 Hz.
Equalization:	NAB. Adjustable to compensate for head wear.
Cue Signals:	NAB primary cue, 1 kHz, standard. Secondary cue, 150 Hz, and tertiary cue, 8 kHz, optional. External information when tone is sensed furnished as relay contact closure.
Playback Time:	NAB size A and B cartridges, 2 seconds to 16 minutes, each shelf.
Start Time:	0.1 seconds, at minimum solenoid damping.
Stop Time:	0.1 seconds, at minimum solenoid damping.
Ambient Temperature:	55 degrees C, 131 degrees F, maximum.
Remote Control:	All controls and indicators.
Mounting:	Table top mounting with rack mounting adapters optional.
Dimensions:	10-1/2" high (add 5/8" for feet); 13" deep, 8-5/8" wide.
Weight:	38½ pounds.
Head Configuration:	NAB (provided with reproduce heads only; except bottom deck supplied with recording head when accompanied by WRA Series Recording Amplifier).

## SECTION II

### INSTALLATION AND OPERATION

### 3D SERIES REPRODUCER

#### A. UNPACKING

Remove the 3D Reproducer from the shipping carton and inspect the unit for damage. All packing material must be retained if a claim for shipping damage is to be filed; and, therefore, should be kept on hand until installation has been completed in case concealed damage is discovered. If shipping damage is found, contact ITC for assistance in the filing of claims.

#### B. INSTALLATION

The 3D Reproducers are supplied in cases prepared for table top mounting. Adapter angle brackets and hardware for mounting in a 19 inch equipment rack are supplied with instructions on an optional basis.

To provide adequate ventilation in rack installations, vertical spacing between Reproducers and other equipment should be from 1¾" to 3½" depending on the temperature inside the closed rack.

#### C. EXTERNAL CONNECTIONS—AUDIO

Audio output connections are made on the six pin sockets J2A, J2B, and J2C. Mating plugs are supplied, and terminal information is as follows:

##### CONNECTOR J-2

Terminal	Function
1	Monophonic Shield (Ground) (left channel stereo)
3	Monophonic Audio Output (left channel stereo -)
5	Monophonic Audio Output (left channel stereo +)
2	Right Channel Stereo Shield (Ground)
4	Right Channel Stereo Audio Output (-)
6	Right Channel Stereo Audio Output (+)

Socket J2A is associated with the top "A" deck while J2B is for the center "B" deck and J2C is for the bottom "C" deck. Socket and terminal locations are shown in Figure 5-2.

The load impedance of the audio output is normally 600 ohms. A 150 ohm output can be provided by changing the transformer wires on connector J2 as noted on the schematic diagram.

In stereo systems, proper phasing of the audio connections must be observed.

#### D. EXTERNAL CONNECTIONS—CONTROL

Remote Control connections are provided on

the fifteen pin sockets J1A, J1B, and J1C. Mating plugs are supplied for this purpose and terminal information is as follows:

##### CONNECTOR J-1

Terminal	Function
1	Ground
2	Remote Start (Run Ground)—Normally Open Switch
3	Remote Start (Ready Ground)—Normally Open Switch
4	Remote Stop (Ready Ground)—Normally Open Switch
5	Remote Stop (Stop Ground)—Normally Open Switch
6	Remote Run Lamp Ground Circuit
7	Remote Ready Lamp Ground Circuit
8	+24 Volts
9-10	Secondary Cue Relay Contacts (Normally Closed)
10-11	Secondary Cue Relay Contacts (Normally Open)
12-13	Tertiary Cue Relay Contacts (Normally Open)
14-15	Cue Audio — Unbalanced Audio Output from Cue Preamplifier; High Impedance (Terminate with 10K ohms or greater)

Socket J1A is associated with the top "A" deck while J1B is for the center "B" deck and J1C is for the bottom "C" deck. Socket and terminal locations are shown in Figure 5-2.

Ground switching is employed in all remote control functions. Normally open, momentary action switches are used for both the remote START and STOP functions. A sample remote control schematic is shown in Figure 10-1.

If necessary, the normally open stop circuit can be replaced with a normally closed circuit by removing the jumper installed inside the machine between pins 3 and 4 on J1 and installing a remote, normally closed switch in its place.

#### E. CONTROL SWITCHES AND INDICATORS

Each of the three tape transport mechanisms (decks) has the following associated control switches and indicators.

##### CARTRIDGE SWITCH

A cartridge Sensing Micro Switch is located on each deck to provide a "Ready" indication to the Reproducer's control circuit and illuminate the yellow indicator lamp just

above the Stop Switch. The Cartridge Switch must be operated in order for the tape transport to be started. See Figure 5-3 for the location of this switch.

**START  
SWITCH**

The Start Switch (green) is used to energize the transport's pressure roller solenoid and put the tape in motion. The indicator lamp in the Start Switch shows that the machine is in a "Run" condition. Location is shown in Figure 5-1.

**STOP  
SWITCH**

The Stop Switch (red) can be used to stop the tape drive system. (Remember that unless a cartridge stops automatically, it will not be properly cued for the next play.)

**READY  
LAMP**

The Ready Lamp (yellow) shows that a cartridge has been properly loaded and the machine is "Ready" to be started.

## **F. OPERATING PROCEDURES**

To play a tape cartridge:

1. Insert a properly recorded tape cartridge into the right-hand side of any of the three cartridge slots.
2. Check to see that the Ready Lamp associated with that deck is illuminated, indicating that the cartridge has been properly inserted and that the deck is "Ready" for operation.
3. Press the Start Switch momentarily. The tape drive system will be started, and tape motion will continue until the primary (1 kHz) cue tone automatically stops the deck or until the Stop Switch for that deck is pressed.



## SECTION III

### PRINCIPLES OF MECHANICAL OPERATION

### 3D SERIES REPRODUCER

#### A. HEAD ASSEMBLY

The reliability and the maintenance required is improved through the use of heads with a metal face and a hyperbolic front contour. The shape and material reduce the need for cleaning and relieve the problems caused by pressure pads. The heads are of plug-in, no mount design and are readily replaced as described in Section IV (Mechanical Adjustments).

The 3D Reproducer deck assembly contains three tape guides of nonmagnetic material which are mounted on the head assembly bracket. The positioning of these tape guides is preset at the factory but may be field adjusted should it be required. The head mounting bracket is of very sturdy construction with the azimuth pivot point located directly behind the center of the heads in both a vertical and horizontal plane. This feature permits azimuth adjustment without disturbing the zenith adjustment. An integral locking screw is provided to prevent movement after adjustment.

#### B. CAPSTAN DRIVE

The proper drive of tape in a cartridge is much more difficult than in reel and other types of tape equipment. The 3D Reproducer is designed and constructed to overcome the difficulties of cartridge tape drive. In a cartridge, the tape pulls from the center and winds back on the outside of an endless loop of tape. Therefore, the tape must slip upon itself as the cartridge plays. This slipping action does not occur at an even rate, and the tape tends to jerk as it pulls from the center of the hub. In addition, the tape is coated with a lubricant which reduces drive friction. One means of improving the tape drive would be to use a larger diameter pressure roller, but this is not possible since there is insufficient clearance in the bottom of the cartridge for a larger roller. The

tape drive required in a cartridge machine is improved by using a 450 RPM (375 RPM in 50 Hz models), direct drive motor with an electrolyzed shaft. The hysteresis-synchronous direct drive motor has a constant speed because there are no belts or pulleys to introduce speed variables.

With a large capstan, directly driven, constant tape drive can be achieved if the tape is not permitted to slip between the pressure roller and the capstan. In the 3D Reproducer, this problem is eliminated by machining the shaft to a very high polish and then blasting it with aluminum oxide particles. This type of finish is a random rough pattern which provides the positive tape drive demanded of cartridge machines. An electrolyzing process holds the roughened pattern and reduces wear of the surface. This finish is very durable and results in a normal wear life of approximately 5 years in normal service.

#### C. PRESSURE ROLLER LINKAGE

The use of a mechanical chain assembly which has a design life in excess of a million operations brings the pressure roller into contact with the capstan. The pressure roller cross-shaft must exert much greater turning torque as the roller contacts the capstan. In the 3D Reproducer the required torque is achieved by using a reliable and efficient chain and sprocket. The shape of the solenoid plunger provides the required torque curve. Correct pressure roller/capstan pressure is achieved by adjusting the clevis screw which attaches the chain assembly to the solenoid plunger.

The solenoid and pressure roller action of the 3D Reproducer is extremely quiet in its operation. The speed and the resultant noise of this assembly is controlled by an adjustable damping valve at the rear of the solenoid. The design is intended to provide long life, dependable operation, and a minimum of maintenance.

**A. GENERAL MECHANICAL INFORMATION**

Tapetronics Tape Cartridge Reproducers have been designed to provide reliable, rugged mechanics which require a minimum of simplified adjustments.

The sequence in which mechanical adjustments are completed, however, is important. Therefore, if a complete check of all mechanical adjustments is required, start at the beginning of this section and check and/or adjust the "C" (bottom) deck as instructed—from Capstan Shaft (Motor) Position to Head Azimuth Adjustment. Then repeat the entire procedure on the "B" (center) deck; and finally, repeat the procedure on the "A" (top) deck.

Head Adjustments, outlined last in this section, may be made without having completed the deck adjustments covered first in this section.

The alignment gauges mentioned in this section are optionally available from Tapetronics.

**B. DECK REMOVAL**

Decks "A" (top) and "B" (center) must be removed to provide access to make mechanical adjustments on the "C" (bottom) deck. When removing decks always remove source power from the equipment.

1. Remove the two top cover retaining screws from the rear chassis and lift off the cover grille.
2. Remove the two front panel 7/64" Allen-type retaining screws (see Figure 5-1), and open the front panel.
3. Unplug the solenoid and head cables from the upper two decks and slide these tape transport mechanisms forward and out of the main chassis.

*The upper deck has been labeled (on its front edge) "A" while the center deck is designated "B."*

**C. CAPSTAN SHAFT (MOTOR) POSITION**

While the adjustment procedure outlined below will normally be required only if the motor has been removed, a check for proper positioning of the capstan should be part of the regular maintenance schedule.

1. "C" (bottom) Deck
  - a. Remove the mounting screws from the top bearing block so that the top end of the capstan shaft is free to move.
  - b. Remove the rubber pressure roller and place the round steel Capstan Shaft Locator Gauge on the pressure roller shaft of the "C" (bottom) deck as shown in Figure 5-7.
  - c. Loosen the motor mounting screws and

manually press the steel Capstan Shaft Locator Gauge against the capstan shaft.

- d. While squeezing the steel gauge and the capstan shaft together, position the capstan shaft as shown in Figure 5-8. The steel tool must lie flat against the capstan shaft to make the pressure roller shaft parallel with the capstan shaft.

*The slight offset between the two shafts allows the tape to come into contact with the capstan shaft before the pressure roller to minimize wow and flutter and to slightly "wrap" around the capstan shaft for better pull.*

- e. Tighten the motor mounting screws and re-check the adjustment.
- f. Replace the rubber pressure roller on its shaft. The steel washer goes on the bottom and the nylon washer goes on the top just under the retainer clip.
- g. Replace the screws in the top bearing block and tighten. Be careful to avoid excessive flexing of the capstan shaft.
- h. Complete the subsequent mechanical adjustments outlined in Section III on the "C" (bottom) deck before starting adjustments on decks "A" and "B."
  - "B" (center) Deck
    - a. Replace the "B" deck (labeled on its front edge) in the main chassis.
    - b. Remove the rubber pressure roller and place the steel Capstan Shaft Locator Gauge on the pressure roller shaft.
    - c. Check to see that the steel tool and the capstan shaft lie flat against each other.
      - (1) If the adjustment is incorrect, first loosen the bearing block mounting screws to make sure that the capstan shaft is not flexed.
      - (2) If the adjustment is still not correct, loosen the screws in the deck stop blocks mounted on either side of the deck on the deck slides (see Figure 5-3), adjust the position of the deck so that the steel tool lies flat against the capstan shaft, and tighten the screws in the deck stop blocks.
    - d. Replace the rubber pressure roller on its shaft, and reconnect the solenoid and head cables. The locator slot in the head socket of mono units must be on the top side to prevent a reversal of the program and cue channels. See the schematic diagram for the color code of

- the head lead arrangement used on stereo units.
- e. Adjust the "set" screws in the front edge of the deck so that a small amount of pressure is exerted against the front panel when it is bolted into place. The purpose of this adjustment is to prevent the deck from being pushed toward the front panel of the machine (thereby destroying the adjustments completed above) when the solenoid is energized.
  - f. Tighten the two front panel retaining screws and complete the subsequent mechanical adjustments outlined in Section IV on the "B" (center) deck before starting adjustments on deck "A."
3. "A" (top) Deck
    - a. Replace the "A" deck (labeled on its front edge) in the main chassis.
    - b. Remove the rubber pressure roller and place the steel Capstan Shaft Locator Gauge on the pressure roller shaft of the "A" (top) deck.
    - c. Check to see that the steel tool and the capstan shaft lie flat against each other. If the adjustment is incorrect, loosen the screws in the deck stop blocks mounted on either side of the deck on the deck slides, adjust the position of the deck so that the steel tool lies flat against the capstan shaft, and tighten the screws in the deck stop blocks.
    - d. Replace the rubber pressure roller on its shaft and reconnect the solenoid and head cables.
    - e. Adjust the "set" screws in the front edge of the deck so that a small amount of pressure is exerted against the front panel when it is bolted into place.
    - f. Tighten the two front panel retaining screws and complete the subsequent mechanical adjustments on the "A" (top) deck.

#### D. PRESSURE ROLLER/CAPSTAN PRESSURE — COARSE SOLENOID ADJUSTMENT

This adjustment is made at the factory and should not normally have to be repeated unless a parts replacement (solenoid, solenoid plunger, linkage chain, clevis, or cross-shaft clamp) has been made in the solenoid linkage assembly. If there is no specific reason for making this adjustment, skip ahead to part "E" of Section IV.

The adjustment procedure outlined below is applicable to all three decks. The front panel must be bolted into its closed position when adjusting sliding decks "A" and "B."

1. Check to see that the steel roll pin protruding from the cross-shaft clamp is inserted between the eleventh and twelfth (counting from the clevis) connector pins

2. in the linkage chain as shown in Figure 5-9.
2. Loosen the clevis locknut and rotate the solenoid plunger and the locknut until the Pressure Roller Compression Tool will fit snugly between the shoulder of the clevis and the locknut as shown in Figure 5-10. The locknut must be finger tight against the plunger. If the tool is not available, the space between the clevis and the locknut should be .2812 (9/32) inch.
3. Remove the capstan motor plug from the socket located on the utility board (see Figure 5-4), and actuate the cartridge sensing micro switch by pushing a piece of folded cardboard or other material between the switch's actuator arm and plunger (Figure 5-3).
4. Press the front panel START switch to energize the solenoid; loosen the screws in the cross-shaft clamp (Figure 5-3). The front panel must be bolted into its closed position when adjusting sliding decks "A" and "B." Adjust the clamp screws so that the clamp is snug on the shaft but can be moved with a small amount of force.
5. Remove the rubber pressure roller and adjust the pressure roller shaft so that the Pressure Roller Compression Gauge fits snugly between the left side of the slot in the deck and the pressure roller shaft as shown in Figure 5-11.
6. Place the steel Capstan Shaft Locator Gauge on the pressure roller shaft, press it tight against the capstan shaft (see Figure 5-7), and tighten the screws in the cross-shaft clamp. If the Capstan Locator Gauge is not available, place a rubber pressure roller on the shaft, press it against the capstan until the rubber is depressed approximately 1/32 of an inch where it makes contact with the capstan shaft, and tighten the screws in the cross-shaft clamp. Pressure is applied by pushing plunger into solenoid, this will keep this linkage taught.
7. Remove the Capstan Shaft Locator Gauge and check the adjustment made in Step 5 above.
8. Replace the rubber pressure roller on its shaft. The steel washer goes on the bottom and the nylon washer goes on the top just under the retainer clip.
9. Plug motor back, check set screws on the front of deck and bolt front panel in place.

#### E. PRESSURE ROLLER/CAPSTAN PRESSURE — FINE SOLENOID ADJUSTMENT

This adjustment will normally be required only after parts replacement; but for best results, a check of the pressure roller/capstan pressure should be on the routine maintenance schedule.

The adjustment procedure outlined below is applicable to all three decks. The front panel must

be bolted into its closed position when adjusting sliding decks "A" and "B."

1. Using the Pressure Roller Compression Gauge, check the distance between the capstan shaft and the pressure roller shaft. The tool should advance to the first "step" and stop as shown in Figure 5-12.
2. If adjustment is required, loosen the clevis locknut and rotate the solenoid plunger as follows (Figure 5-3):
  - a. To increase the pressure, rotate the solenoid plunger so that it penetrates deeper into the solenoid (clockwise as viewed from the front panel). This will increase the pull of the solenoid on the plunger and, therefore, the pressure roller/capstan pressure will be increased. The plunger must not "bottom out" to the seat of the solenoid.
  - b. To decrease the pressure, rotate the plunger counterclockwise as viewed from the front panel.
3. Tighten the clevis locknut when the proper pressure has been achieved. (If proper adjustment cannot be attained, complete the coarse adjustment outlined in part "D" of Section IV before repeating the fine adjustment.)

#### F. SOLENOID DAMPING

The air damping of the solenoid is controlled by the adjustment of the set screw at the rear end of the solenoid seat. The speed of the solenoid operation is proportional to the speed at which air is allowed to move through the small hole on the underside of the solenoid seat. The noise of the solenoid operation shares the same relationship.

The adjustment procedure outlined below is applicable to all three decks. See Figure 5-3 for parts location. This adjustment in no way affects pressure roller/capstan pressure as in some machines of older design.

1. Loosen the locknut on the Solenoid Damping Set Screw.
2. Turn the Damping Screw clockwise to reduce, or counterclockwise to increase the speed of the solenoid operation. The average length of time for the solenoid to retract is .01 sec.
3. Check the adjustment by inserting a cartridge and starting the Reproducer. Repeat the adjustment as required.
4. Tighten the locknut.
5. Check the "set" screws in the front edge of the deck for a slight pressure when front panel is closed.

#### G. RIGHT CARTRIDGE GUIDE

The right cartridge guide controls the cartridge positioning in relation to the heads, capstan shaft, and pressure roller shaft. Proper location of this cartridge guide is essential to proper operation of

the machine. The right cartridge guide is properly positioned at the factory and should not normally require adjustment.

The adjustment procedure outlined below is applicable to all three decks.

1. Loosen the right cartridge guide mounting screws and insert a cartridge into the deck.
2. Adjust the cartridge so that the pressure roller shaft is centered in the "keyhole" in the cartridge.
3. Position the cartridge guide 1/64 of an inch from the cartridge and at a right angle with the front edge of the deck.
4. Tighten the cartridge guide mounting screws.
5. Press the start switch and, with the cartridge playing, check to see that the cartridge is free to move approximately 1/64 of an inch in and out and from left to right. If the cartridge is tight in the machine, recheck all mechanical adjustments.

#### H. LEFT CARTRIDGE GUIDE

The left cartridge guide is intended to help guide the cartridge into the machine and prevent damage to a head due to improper loading. When NAB type B cartridges are used, the left cartridge guide must be removed.

The adjustment procedure outlined below is applicable to all three decks.

1. With a cartridge in the machine, position the end of the left cartridge guide nearest the front panel approximately 1/8 of an inch from the cartridge and snug down the mounting screw nearest the front panel.
2. Position the end of the left cartridge guide nearest the head assembly approximately 1/32 of an inch from the cartridge.
3. Tighten both mounting screws.

*The left cartridge guide should not come into contact with the cartridge when the cartridge has been properly inserted into the machine. Its purpose is to simply guide the cartridge into place—not to hold it there.*

#### I. TAPE GUIDE ADJUSTMENT

The Three Deck Reproducer has three independent tape guides on each deck to provide the maximum of tape guidance outside of the cartridge. The left tape guide has been specially formed to provide clearance for the corner post in the cartridge.

For optimum performance, not only should a check for proper tape guide positioning be made, as outlined below; but, also the positioning of the corner post in the cartridges should be checked and adjusted as shown in in Figure 5-16.

The adjustment procedure outlined below is applicable to all three decks.

1. Check the positioning of each tape guide by advancing the Tape Height Gauge into

the tape guide as shown in Figure 5-13. The gauge should advance fully into the tape guide, without friction, while resting flat on the deck—not tilted as shown by the dashed line (or its opposite) in Figure 5-13. The tape height gauge should be demagnetized so that it will not effect the “heads.”

2. If adjustment is required, loosen the two tape guide mounting screws.
3. Keeping the Tape Height Gauge flat on the deck, position the tape guide as shown in Figure 5-13.
  - a. Keep the tape guides as close to the head as possible without coming into contact with the head mounting blocks or any parts mounted on these blocks.
  - b. Keep the tape guides vertical. Normally, the bottom edge of the tape guide’s mounting surface should rest on or very near the surface of the deck plate.
4. Tighten the tape guide mounting screws and re-check the adjustment.
5. Check and adjust as required the other tape guides.

The slot in the tape guide is .249 inch wide. (Actual tape width is  $.246 \pm .002$  inch.) The width of this slot can also be properly gauged with the Tape Height Gauge. The arm on the gauge should advance fully into the slot without friction, but there should be no room for noticeable movement of the foot in the slot.

Adjustments obtained with the Tape Height Gauge should be accurate to less than .001 of an inch—much better than that obtained with most inexpensive optical devices.

## J. HEAD HEIGHT ADJUSTMENT

The adjustment procedure outlined below is applicable to all three decks. See Figure 5-3 for the location of the adjustment screws mentioned below.

1. Loosen the Lock Screw L by turning it counterclockwise approximately four complete turns.
2. **Course Height:** Adjust the Front Height Screw FH until the top of the upper head track (pole piece) is 9/16 of an inch above the deck surface.
3. **Course Zenith:** Adjust the Rear Height Screw RH until the face of the head is perpendicular with the surface of the deck. Position the Tape Height Gauge (or any gauge known to be square) on the deck surface and move it against the face of the head as shown in Figure 5-14. The gauge used should be demagnetized before using for adjustment. Be careful to avoid scratching the face of the head. When the head is perpendicular, the face of the head and the “square” will be flush.

4. **Fine Height and Zenith:** This adjustment is made by using a strip of white “leader” tape or a piece of recording tape from which the oxide has been removed. (Shellac thinner, flux remover or a similar solvent will loosen the oxide which can then be wiped off the transparent base.) A test cartridge may be used for this adjustment (refer to Section VIII).

- a. Position the transparent tape across the face of the heads as the tape would be positioned if a cartridge was being played. See Figure 5-15. Check to see that the tape is not being distorted (wrinkled) where it makes contact with the tape guides and attach it to one of the tape guide support blocks with adhesive tape to free one hand for adjustments.
- b. Alternately adjust Height Screws FH and RH to position the top of the upper head track (pole piece) so that it is even with the upper edge of the tape, and to position the bottom of the lower head track (pole piece) so that it is even with the lower edge of the tape. Screws FH and RH should be adjusted by equal amounts in the same direction.
- c. Re-check the zenith of the head as instructed in Step 3 above.
- d. Remove the transparent tape.

## K. HEAD AZIMUTH ADJUSTMENT

The adjustment procedure outlined below is applicable to all three decks. See Figure 5-3 for the location of the adjustment screws.

1. Insert a test cartridge with a 15 kHz azimuth alignment tone. The test cartridge **must** be checked for correct tape tracking or the resulting azimuth adjustment will not be correct. (Check corner post and pressure pads)
2. Meter the output of the Reproducer and adjust Azimuth Screw A of the reproducing head for maximum output level.
3. Tighten Lock Screw L and re-check the meter output to correlate with Step 2.
4. **Record Head Azimuth Adjustment:** Record head adjustment required when used with recording equipment.
  - a. Perform the record head adjustments (mechanical) as outlined for the playback head.
  - b. Select an erased 3½ minute cartridge. (This cartridge should have the corner post properly positioned and be maintained as a test cartridge.)
  - c. Feed a 15 kHz tone into the recorder 10 db below normal level.
  - d. Meter the output of the reproducer and adjust azimuth screw A of head B, the

recording head, for maximum playback output level while recording the 15 kHz tone (see Figure 5-3).

- e. Tighten lock screw L of the record head.

#### L. HEAD REPLACEMENT

The Tapetronics Reproducers utilize the no-mount type heads to provide quick and easy installation.

1. Loosen the two screws in the head mounting strap.
2. Remove the old head and insert a new one. (The side of the head with the printing on

it should be positioned up.)

3. Align the rear edge of the head case so that it is flush with the rear edge of the head mounting strap.
4. Tighten the screws in the head mounting strap.
5. Reconnect the head cable. The locator slot in the head socket of mono units must be on the top side to prevent a reversal of the program and cue channels. See the schematic diagram for the color code of the head lead arrangement used on stereo units.
5. After head replacement it is necessary to adjust the heads as described in (J) & (K).

# SECTION V

## MECHANICAL DRAWINGS

## 3D SERIES REPRODUCER

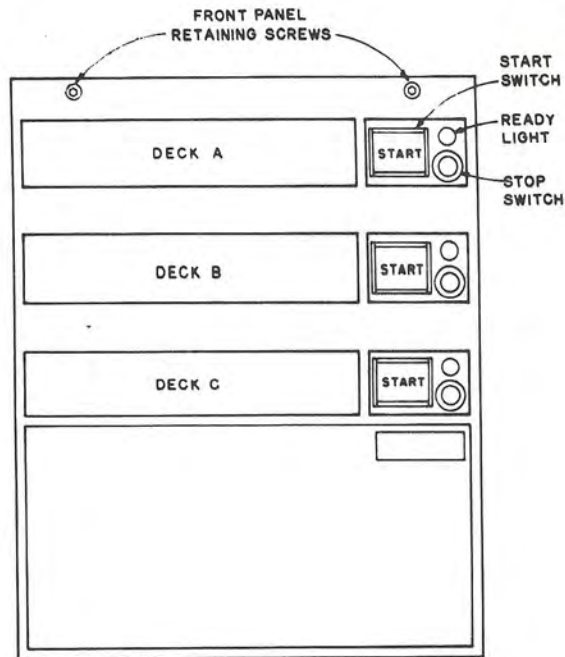

FIGURE 5-1  
3D, FRONT VIEW

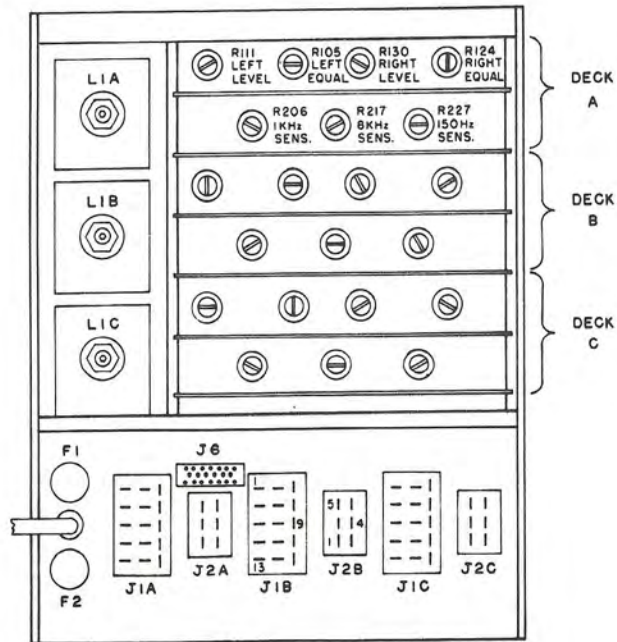

FIGURE 5-2  
3D, REAR VIEW

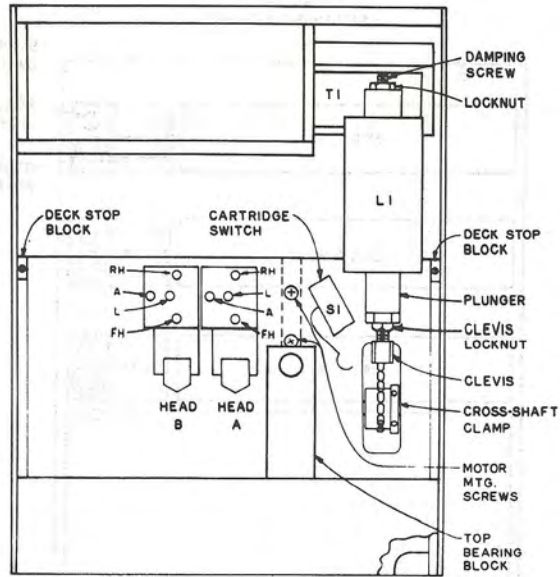

FIGURE 5-3  
3D, TOP VIEW

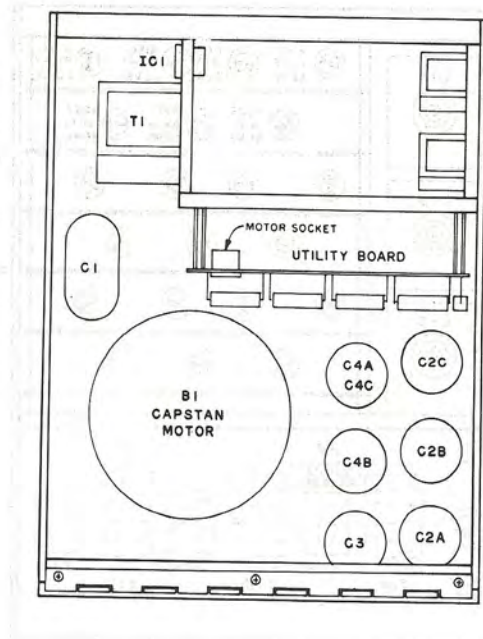

FIGURE 5-4  
3D, BOTTOM VIEW



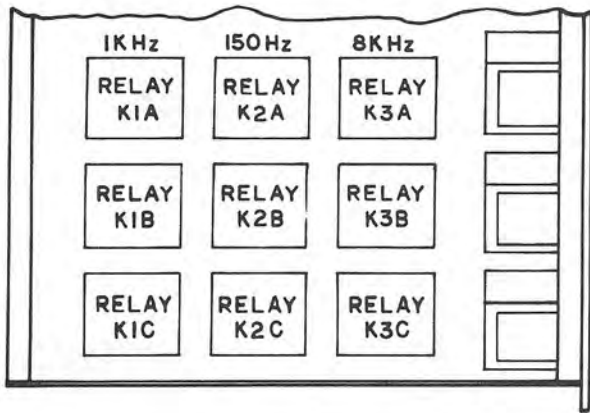

FIGURE 5-5  
3D RELAY CHASSIS, REAR VIEW

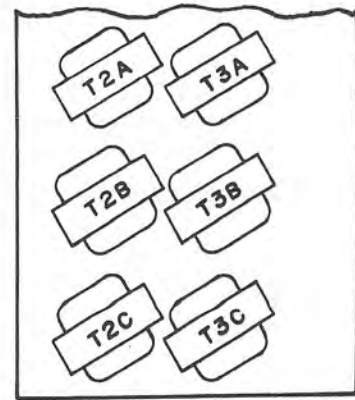

FIGURE 5-6  
3D OUTPUT TRANSFORMER LAYOUT

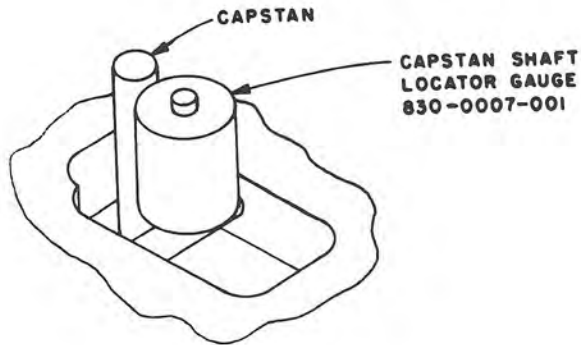

FIGURE 5-7  
CAPSTAN SHAFT ALIGNMENT

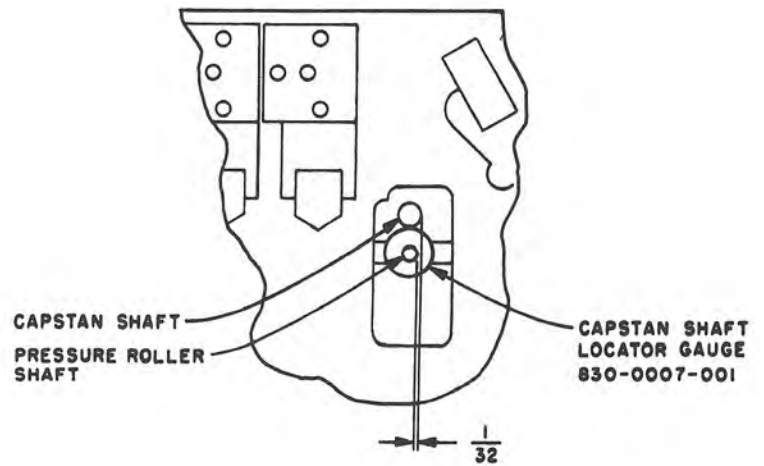

FIGURE 5-8  
CAPSTAN/PRESSURE ROLLER SHAFT ALIGNMENT

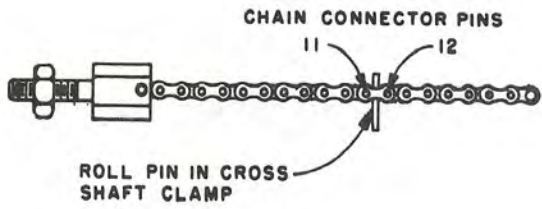

FIGURE 5-9  
LINKAGE CHAIN POSITIONING

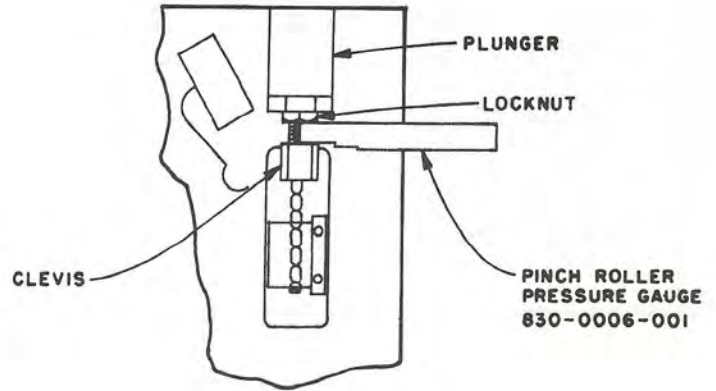

FIGURE 5-10  
PRELIMINARY PLUNGER ADJUSTMENT

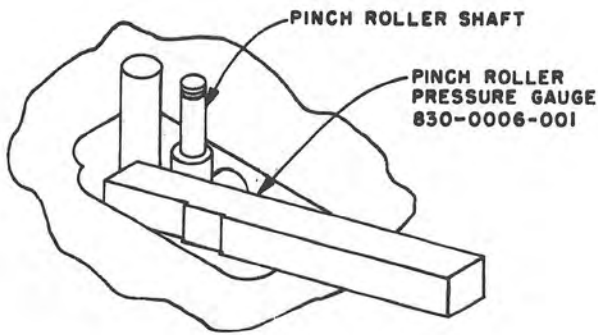

FIGURE 5-11  
PRESSURE ROLLER SHAFT ALIGNMENT

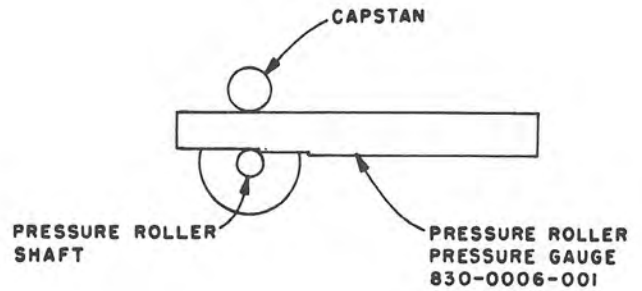

FIGURE 5-12  
TEST OF PRESSURE ROLLER PRESSURE

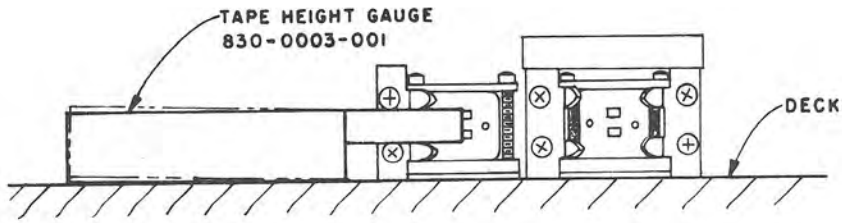

FIGURE 5-13

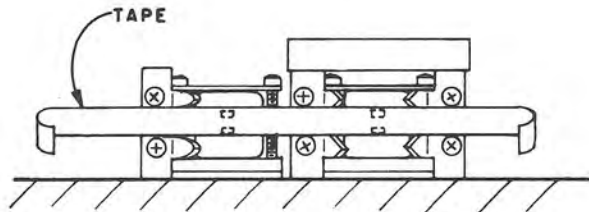

FIGURE 5-15

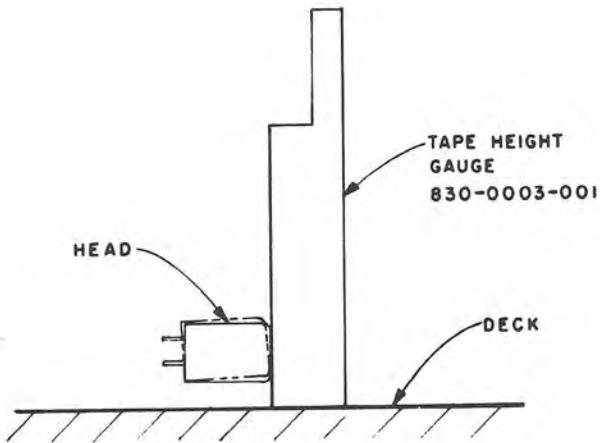

FIGURE 5-14

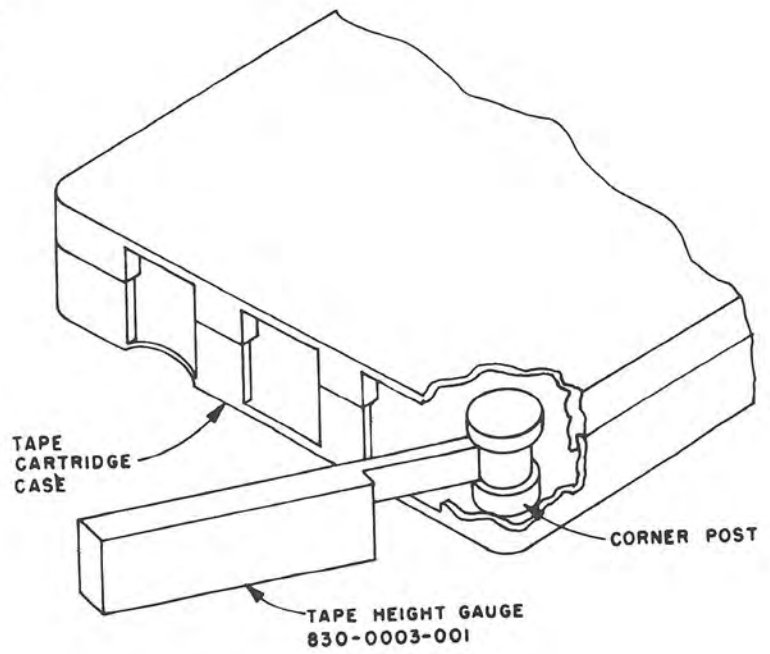

FIGURE 5-16

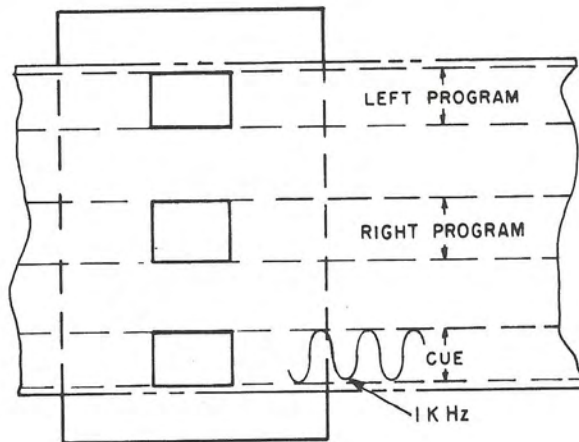
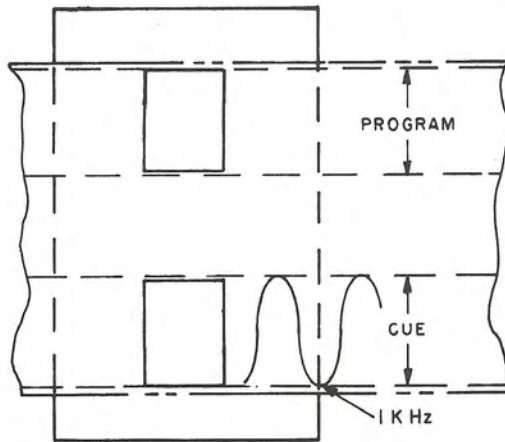

FIGURE 5-17

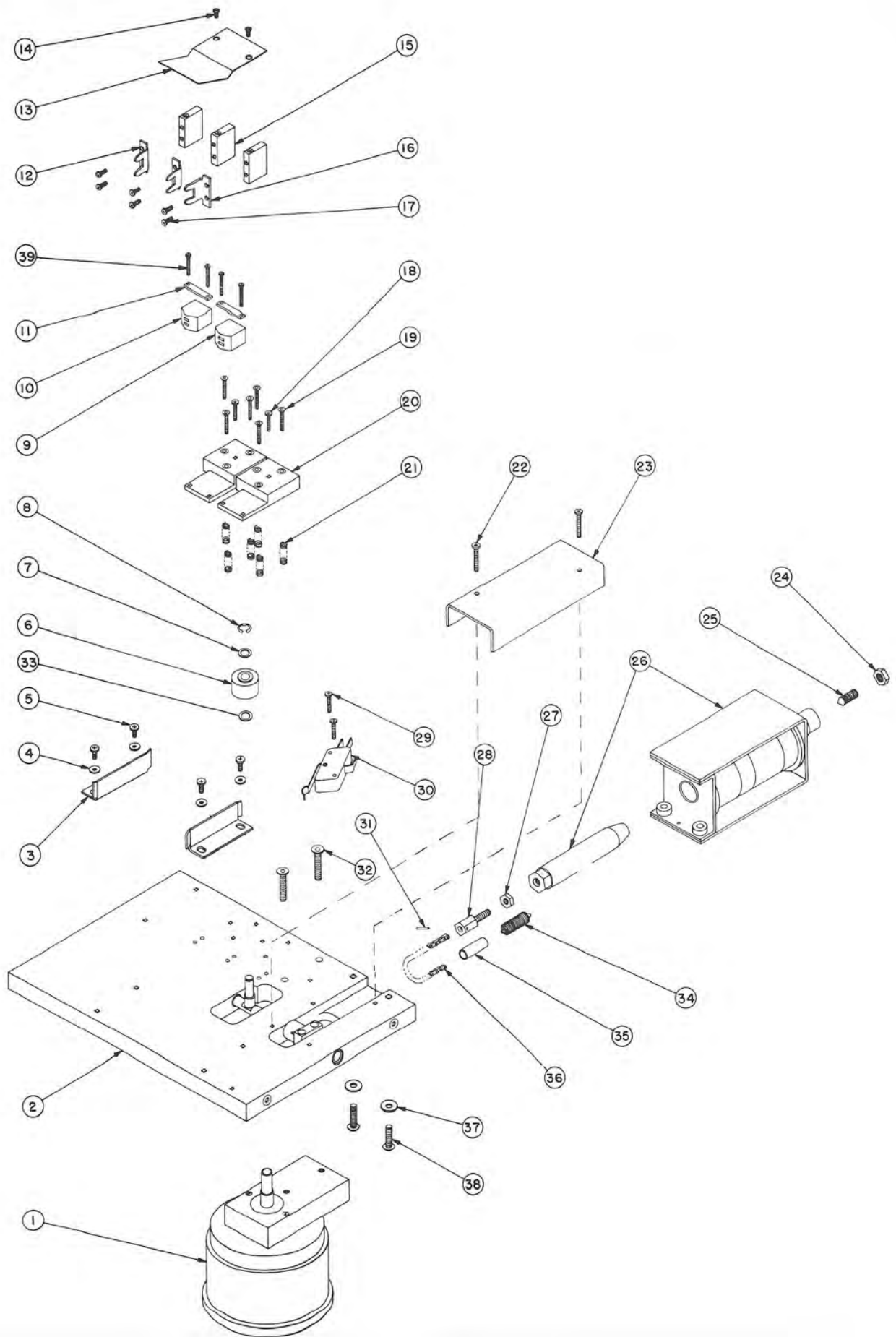

FIGURE 5-18

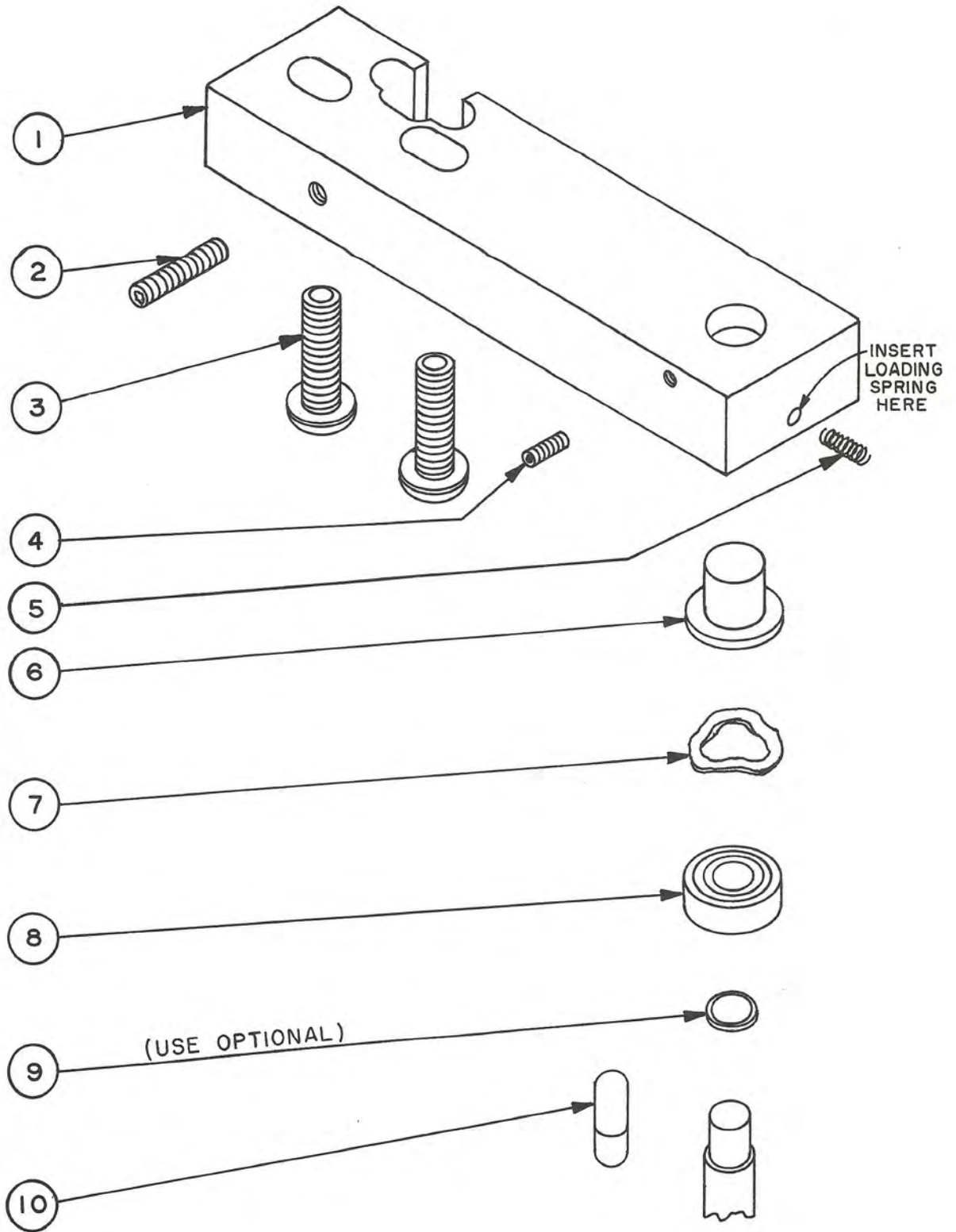

FIGURE 5-19

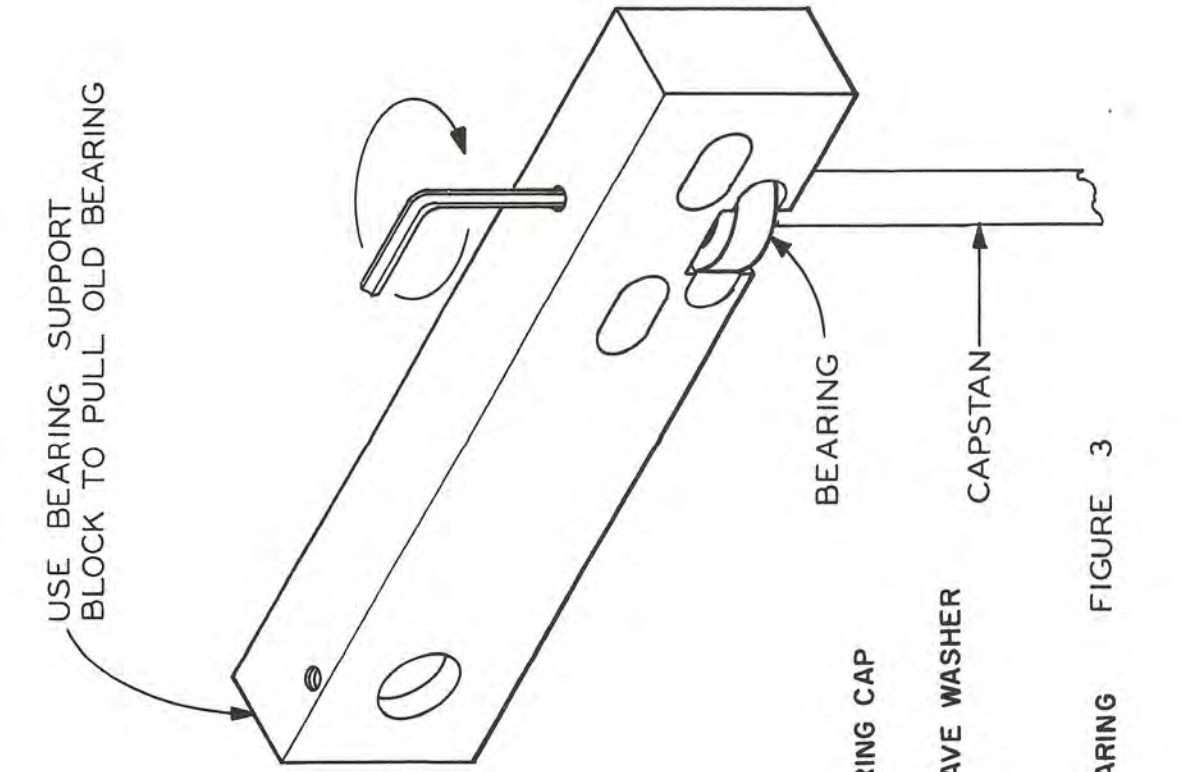

FIGURE 3

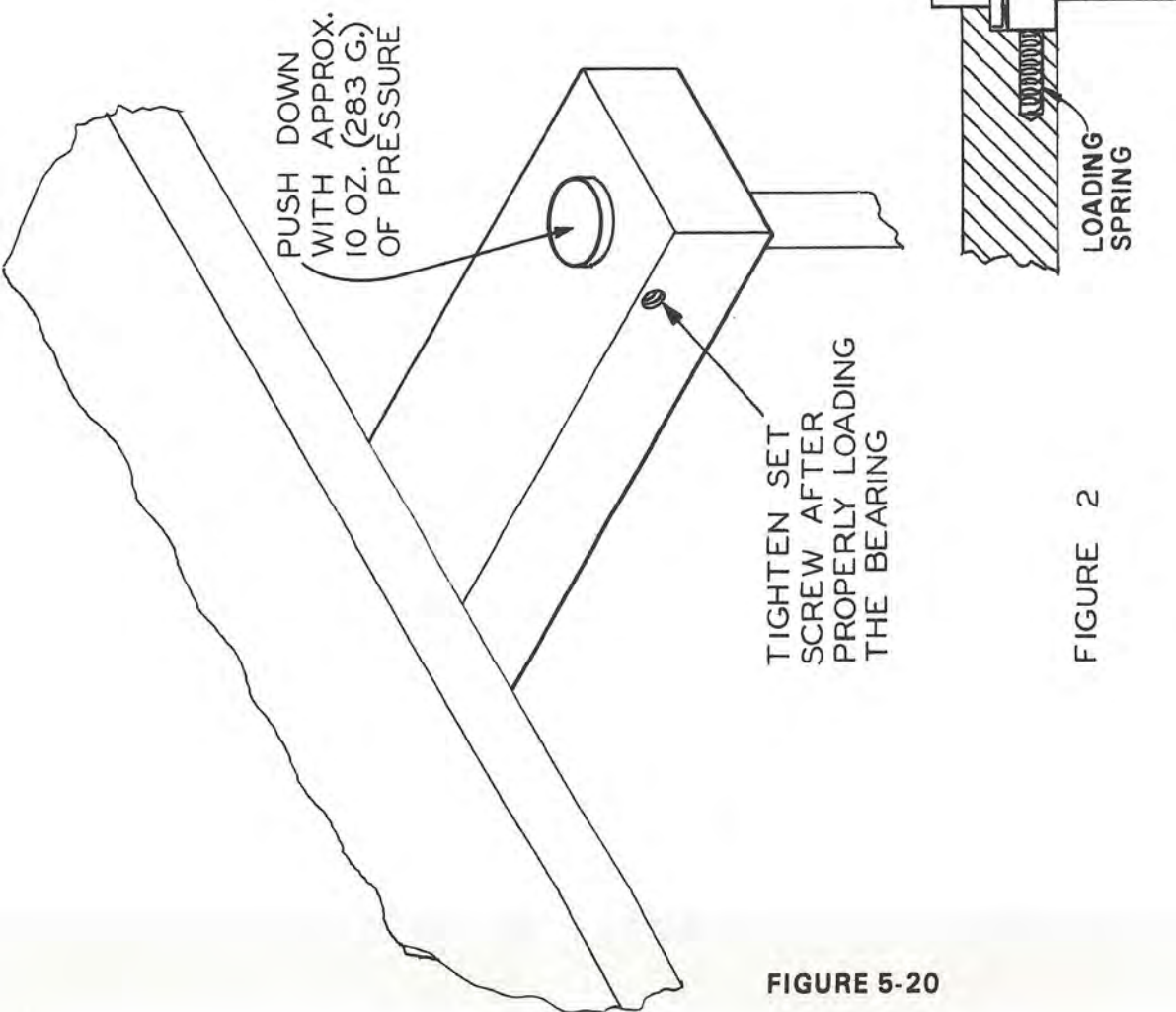

FIGURE 2

FIGURE 5-20

## SECTION VI

### MECHANICAL PARTS LIST

### 3D SERIES REPRODUCER

(See Figure 5-18)

Item	Part Number	Description	Item	Part Number	Description
1	451-0003-010	Motor, Capstan, 450 RPM, 110 V., 60 Hz, 6 inch shaft	25	355-1102-000	Screw, Set, Solenoid Damping
	451-0008-010	Motor, Capstan, 500 RPM, 110 V., 50 Hz, 6 inch shaft	26	477-0003-002	Solenoid Coil and Plunger
2	267-0003-012	Deck, Fixed, 3D Series	27	370-1001-000	Nut, Lock, Clevis Screw
	267-0002-013	Deck, Movable, 3D Series	28	264-0001-001	Clevis, Screw (Solenoid Linkage)
3	272-0001-001	Guides, Cartridge (two)	29	350-0420-000	Screws, Micro Switch Mtg., (two)
4	360-0601-000	Washers (four)	30	392-0001-000	Switch, Micro
5	350-0604-000	Screws, Cartridge Guide Mtg. (four)	31	282-0001-001	Pin, Roll
	360-1005-000	Washer, steel	32	353-0004-000	Screws, Motor Mounting
6	291-0003-001	Pressure Roller	34	301-0002-000	Spring, Expansion, Solenoid Linkage Return
7	359-0006-000	Washer, mylar	35	441-0004-010	Tubing
8	289-0002-000	Clip, retainer	36	277-0001-000	Chain, Solenoid Linkage
9	504-0002-000	Head, Mono Reproduce, Nortronics, PB2H7KNO	37	360-1003-000	Washers, (two)
	504-0004-000	Head, Stereo Reproduce, Nortronics, PB3Q7KNO	38	353-0003-000	Screws, Solenoid Mounting (two) (See Figure 5-19)
10	504-0001-000	Head, Dummy, Nortronics B12NO	1	284-0001-000	Cap, Bearing Block (hole plug)
	504-0003-000	Head, Mono Record, Nortronics PB2H4RNO (on "C" Deck only when used with recording amp)	2	253-0008-001	Block, Top Bearing
	504-0005-000	Head, Stereo Record, Nortronics PB3Q4RNO (on "C" Deck only when used with recording amp)	3		Screws, Bearing Block Mtg.
11	303-0001-001	Straps, Head Mounting (two)	4	361-0001-000	Washer, Wave
12	350-0307-000	Screws, Head Mtg. (four)	5	311-0011-000	Boot, Bearing
13	301-0001-000	Spring, Cartridge Hold-Down	6	251-0003-000	Bearing, Top
14	350-0402-000	Screws, Cartridge Spring Mtg. (two)	7	311-0012-000	Ring, "O"
15	304-0001-001	Supports, Tape Guide (three)	8	359-0003-000	Washers, Shim, mylar, .265 1D, 7/16 OD
	272-0003-001	Guide, Tape, Left (one)			
16	272-0002-002	Guides, Tape, Center and Right (two)			
17	350-0403-000	Screws, Tape Guide Mtg., (six)			
18	350-0415-000	Screws, Head Block Locking, (two)			
19	353-0001-000	Screws, Head Block Azimuth and Height (six)			
20	253-0001-002	Blocks, Head Mounting (two)			
21	301-0003-000	Springs, Compression, Head Block Support (six)			
22	350-0422-000	Screws, Solenoid Plunger Cover Mtg., (two)			
23	265-0009-011	Cover, Solenoid Plunger			
24	372-1101-000	Nut, Lock			

#### MISCELLANEOUS MECHANICAL PARTS

290-0001-000	Slides, Deck
253-0007-001	Blocks, Deck Stop (four)
250-0624-000	Screws, (for above)
355-0601-000	Screws, set (In front of sliding decks)
293-0002-013	Grille, bottom
293-0003-014	Grille, top
311-0010-000	Foot, plastic
830-0003-001	Gauge, Tape Height
830-0006-001	Gauge, Pressure Roller Pressure
830-0007-000	Gauge, Capstan Shaft Locator



## SECTION VII

### PRINCIPLES OF ELECTRICAL OPERATION

### 3D SERIES REPRODUCER

#### A. GENERAL INFORMATION

This section of the manual describes the electronic circuitry and the way in which it works. The symbol designations referred to are used on the schematic diagram for the 3D Series Reproducer. (The schematics are located in Section XIV.)

#### B. SOLENOID POWER SUPPLIES

Diodes CR1, CR2, CR3, and CR4 are a full wave bridge rectifier which furnishes 110 volts DC to the solenoid power supply filter. The dual section filter consists of R1, R9, and the two sections of C2. The diodes and resistors are located on the Utility Power Supply board (see Figure 5-4 for the board location) while the filter capacitors are mounted on the under side of Deck C, the bottom deck (see Figure 5-4). The output of 110 volts DC (under load) is switched by the parallel contacts 7 and 11 / 8 and 12 of control relay K1. A network consisting of C13 and R17 is across the coil of each solenoid L1 for transient protection when power is removed.

#### C. LOW VOLTAGE POWER SUPPLY

Transformer T1 provides low voltage AC (with the center tap grounded) to diodes CR6 and CR7, a full wave rectifier that supplies the input to the regulated power supply. Capacitor C3 acts as an input filter. The diodes and resistors of this power supply are mounted on the Utility Power Supply board (see Figure 5-4 for the board location) while the filter capacitors are located on the under side of the deck (see Figure 5-4).

IC1 is the regulated power supply. (See Figure 5-4 for location.) The output of this power supply is +24 volts. The regulated power supply is protected by F1, a fast acting fuse. The output of the regulated power supply is represented on the schematic diagram by a triangle which is common to all other points on the schematic shown with a like symbol. R3 and C4 provide decoupling and additional filtering for the program amplifier card.

The case of IC1 is insulated from the chassis by a mica washer to prevent hum loops. To provide maximum heat dissipation, the mica washer is coated on both sides with thermal conductive agent and IC1 is held firmly in place with two mounting screws.

#### D. CONTROL CIRCUITRY

The chassis control circuitry is furnished with power by the low voltage DC power supply and utilizes ground switching. At all times other than when a primary (1 kHz) cue tone is being detected, positive voltage is routed from the low voltage DC power supply through R215 and CR205 on the cue card to control relay, K1. When a cartridge has been properly inserted in the deck, the cartridge sensing micro switch S1 closes furnishing ground information through contacts 2 and 10 on relay K1 and pin 2 on J5 to the stop cue tone protection circuit on the cue card, the action of which is described under Cue Circuitry. This same "ready" ground is furnished through CR8 and R4 to illuminate I3, the "ready" lamp, and through R5 to a remote "ready" lamp.

The ground furnished through S1 is routed to S3, the Stop Switch, through pin 4 on J1 to a remote stop switch, through the jumper installed between pins 3 and 4 on J1 to S2, the Start Switch, and through pin 3 on J1 to a remote start switch. On the bottom deck the ground arriving at the Start Switch is also made available to a recording amplifier through pin 18 on J6 and through contacts 9 and 1 on K1 and pin 15 on J6.

With conditions described above, pressing the Start Switch presents a ground to pin 13, the coil of K1, the control relay, which energizes and holds itself energized by closing contacts 5 and 9. Contacts 1 and 9 open removing the "ready" ground from the recording amplifier. Contacts 2 and 10 open removing the "ready" ground from the stop tone cue protection circuit and the Ready lamps. Contacts 6 and 10 close providing a ground through R6 to a remote run lamp and to the audio squelch to turn on the audio. Parallel contacts 7 and 11 / 8 and 12 close completing the circuit to energize the solenoid.

When a primary (1 kHz) cue tone is detected, transistor Q203 turns on and takes the junction of R215 and CR205 to ground, removing the positive holding voltage from K1.

Pressing S3, the Stop Switch, accomplishes the same thing with a normally open, momentary action switch which eliminates the disadvantages of a series stop circuit. If for any reason a series remote stop circuit is required, the normally open stop circuit can be replaced with a normally closed circuit by removing the jumper installed inside the machine between pins 3 and 4 on J1

and installing a remote, normally closed switch in its place.

When a secondary (150 Hz) cue tone is sensed, relay K2 is energized. A contact closure is then provided on pins 10 and 11 of J1 by parallel contacts 5 and 9 / 6 and 10. The closure of contacts 8 and 12 shorts out dropping resistor R7 providing a brighter illumination of the Run Lamp as an indication of 150 Hz cue tone detection. Contacts 7 and 11 short out R6 in the remote run lamp circuit.

Relay K3 is energized when an 8 kHz tone is detected. A contact closure is provided on pins 12 and 13 of J1 by parallel contacts 5 and 9 / 6 and 10. The closure of contacts 8 and 12 provides an indication of the 8 kHz cue tone detection by returning the ground to the Ready Lamp circuit. Diode CR8 functions as a blocking diode and prevents this ground from being presented to the stop cue tone protection circuit.

## E. CUE CIRCUITRY

The plug-in Cue Detector card is located at the rear of the deck assembly. The 1 kHz Primary Cue detector and the optional 150 Hz and 8 kHz detectors when so equipped are designed to operate from tones as specified in the NAB Standards.

Transistors Q210 and Q211 are the equalized preamplifier stages which provide essentially equal voltage for each of the normal level cue tones to the common signal bus of the three detectors (when so equipped).

Diodes CR201 and CR202 act as a signal limiter to prevent the signal bus from exceeding the detector input maximum level of approximately .5 volts. This bus is also supplied to the remote socket J1 (Pin 15) and to the recorder meter circuits via J6 (Pin 2) of WP Series Reproducers.

The 1 kHz Primary Cue section contains a stop cue tone protection circuit which prevents the machine from being stopped by a 1 kHz tone for approximately two seconds after the unit is started. While the reproducer is sitting idle with a cartridge inserted (cartridge sensing micro switch S1 closed), capacitor C206 is discharged through R204, CR203, contacts 2 and 10 of relay K1, and S1 to ground. When the reproducer is started, the discharge path is opened by relay K1, and C206 begins to be charged by the 24 volt DC power supply through resistor R203. While C206 is charging, the base of Q201 is clamped sufficiently close to ground to prevent operation of the 1 kHz detector. When C206 is charged to approximately 11 volts, diode CR204 is reverse biased and the lamp is removed.

In the 1 kHz Primary Cue Section, a series resonant circuit consisting of L201, C208 and C209 provides a low impedance regenerative cir-

cuit for Q201 at 1 kHz, while attenuating frequencies more than a few percent above or below 1 kHz. Transistor Q202 is a zero bias signal rectifier which amplifies positive current pulses present at its base. R212, R213 and C210 act as the rectifier load and coupling network to switching transistor Q203. This configuration also acts to filter out any transients that may be present on incoming signals. Q203 diverts current flow from relay coil K1 during the cue tone and causes it to de-energize and stop the tape drive.

The operation of the 150 Hz Secondary and 8 kHz Tertiary Cue sections is, in principle, the same — except that the tuned circuit is designed for the respective frequency. Since no tone protection is provided in these circuits, the 150 Hz and 8 kHz detectors are free to operate at any time. Switching transistors Q209 and Q206, when conducting, operate relays K2 and K3 respectively.

NOTE: The NAB standards specify that the Primary Cue tone oscillator generate a tone of 925 Hz to 1075 Hz. Many older cartridge recorders produce a stop cue tone that is well outside these tolerances.

A broad-band cue detector is supplied in ITC single cue tone machines. This broad-band cue detector will pass a wide range of frequencies which permits proper cueing of cartridges recorded on older machines. The broad-band characteristics will cause no problem as long as only single cue tone operation is used. Components C220 and C221 provide the broad-band operation.

The broad-band detector can be changed to the narrow band mode (1 kHz  $\pm$  75 Hz) by removing the white wire strap that is on top of the detector PC card. In addition, it may be necessary to increase the gain of the detector by turning the sensitivity control clockwise. (The detector has about 10 dB less gain in the narrow band mode.)

## F. PROGRAM PLAY CIRCUITRY

The program play amplifier is located on the plug-in PC Card immediately to the rear of the deck assembly. Single monophonic or dual stereophonic amplifiers of identical design are on the same card, depending upon machine design.

Transistors Q101 and Q102 are the high stability equalized pre-amplifier stages. Adjustable AC feedback equalization is employed to improve input impedance. These components are C104, R104 and R105 in the L. Channel amplifier. Out-

put from these stages is coupled through the electronic attenuator IC101 to the gain control R111. Audio is muted by IC101 in all but the run mode. Transistors Q103 and Q104 are conventional voltage amplifiers, each with local AC feedback employed. The output is connected via edge pin 1 to the balanced output transformer T2. Output impedance is normally 600 ohms but may be changed to 150 ohms by re-connection of the secondary wires. Refer to the schematic notes.

## ELECTRICAL ADJUSTMENTS

## 3D SERIES REPRODUCER

## A. CONTROLS

The various electrical controls listed below are adjusted at the factory to provide optimum operation of the ITC Reproducer. At the time of installation, the only control which may require adjustment is Program Level.

A good maintenance schedule will include periodic checks (weekly or monthly—depending upon operational requirements) of the machine's electronics, but always remember to check the adjustment of and demagnetize heads first. Small adjustments of the electronic controls may be required to compensate for normal head wear, but large adjustments may indicate the need for head replacement or further testing.

See Figure 5-2 for the location of the electronic controls, and notice that all controls, both program and cue, are duplicated for each deck.

1. **Program Level:** The output level of the program amplifier(s) is factory adjusted for 0 dBm when reproducing a "standard level" tone. R111 is the control for mono reproducers and the left channel of stereo units. R130 controls the right channel of stereo machines. If the output level must be reduced below -10 dBm, an external pad should be installed to maintain the best possible signal to noise ratio.
2. **Program Equalization:** Equalization of the program amplifier(s) is factory adjusted to

conform with NAB equalization curve. The equalization control(s) may be used to compensate for head wear and for small variations in heads when replacement is required. The equalization control for mono and the left channel of stereo units is R105 while R124 is the control for the right channel of stereo reproducers. The equalization control(s) should be adjusted to provide the smoothest possible response during the reproduction of a frequency response test cartridge.

3. **Primary (1 kHz) Cue Sensitivity:** The sensitivity of the 1 kHz Primary Cue Detector is increased by turning R206 clockwise. This control is normally set to respond to a 1 kHz tone 8 dB below the NAB level for this tone.
4. **Secondary (150 Hz) Cue Sensitivity:** Turning R227 clockwise increases the sensitivity of the Secondary (150 Hz) Cue Detector and is normally adjusted to respond to a 150 Hz tone 10 dB below the NAB level for this tone.
5. **Tertiary (8 kHz) Cue Sensitivity:** To increase the sensitivity of the Tertiary (8 kHz) Cue Detector, turn R217 clockwise. Normal adjustment will allow the 8 kHz Detector to respond to a tone 10 dB below the NAB level for this tone.

## TEST CARTRIDGES

## A. PREVENTIVE MAINTENANCE

Preventive maintenance of the electrical adjustments should be done on monthly schedule. Each installation should be equipped with a primary test cartridge such as the NAB Standard Test Tape.

Should a primary test cartridge be used to test several tape transports on a monthly basis, the short wave length sensitivity will be degraded by repeated playing. The proper handling and storing of the Primary Test Cartridge, and proper cleaning of heads and tape guides will minimize signal loss. The best method to preserve a primary test cartridge is to record your own test cartridges as outlined below and compare them with the primary test cartridge every six months. It is important that all test cartridges contain the same type of tape that is used for normal recording.

## B. TEST CARTRIDGES

1. **Test Cartridge No. 1:** Carefully align the reproducer to the Primary Test Cartridge for azimuth and level. Verify the proper adjustment of the recorder electronics and the recording head azimuth. Select a properly erased cartridge of known good guidance. Record a 15 kHz azimuth tone at -10 dB level for 30 seconds. Follow this tone with 400 Hz, 10 kHz, 5 kHz, 2500 Hz, 1 kHz, 250 Hz, 100 Hz and 50 Hz tones at -10 dB level and 5 seconds duration. The last tone should be 400 Hz at 0 dB level of 20 seconds duration. This tape can now be used for day to day response tests as a second generation standard.
2. **Test Cartridge No. 2:** (Refer to the recorder instructions for adjusting the level of the tone oscillators.) Temporarily connect the cue head to the properly calibrated program amplifier input. With an erased tape, adjust these tone oscillator levels to 8 dB below normal. The program amplifier will play at -7.6 dB for 1 kHz, -1.9 dB for 150 Hz and -17.4 dB for 8 kHz. Record each tone at an interval of approximately 5 seconds at this level. Set this tape aside. With another tape, return the tone oscillators to their proper settings (+0.4 dB for 1 kHz, +6.1 dB for 150 Hz, and -9.4 dB for 8 kHz). The -8 dB tone tape may now be used as required to adjust the tone detector levels to just reliably operate at the -8 dB from normal tone level setting.
3. **Test Cartridge No. 3:** Using a long car-

## 3D SERIES REPRODUCER

tridge, record a single 1 kHz cue tone on the cue track. Accurately time this cartridge in several machines. Average the playing time and mark the exact time on the rear of this cartridge.

If a frequency counter is available, record a 12 kHz tone on the program track at -10 dB. Play this cartridge in two or more tape transports and measure the frequency of the tone. Average the measurements and mark the frequency on the rear of the cartridge.

4. **Test Cartridge No. 4:** This cartridge is to be used for the height adjustment of the heads during the run mode. The cartridge has the pressure pads removed and the top section is cut out to allow observation of the tape travel across the heads. Since the pressure pads are removed, the tape travel across the cartridge face must be checked to be sure it is parallel with the base of the case.

## C. USE OF TEST CARTRIDGES

1. **Mechanical Head Adjustment:** Place test cartridge No. 4 in the tape transport and check the tape travel across the tapeheads. (Refer to Figure 5-15.) If the tape travel is incorrect, perform adjustment in accordance with Section 4.
2. **Program Playback Level:** The output level of the program amplifier is factory adjusted for 0 dBm when reproducing the NAB Standard Reference Level Tape, 400 Hz. Test cartridge No. 1 may be used to adjust this level as required. Refer to Section 8-1 for these adjustments.
3. **Program Playback Equalization:** Equalization of the program amplifier(s) is adjusted for flattest response. Test cartridge No. 1 may be used to adjust this response when necessary. It is cautioned not to attempt this adjustment until reproduce head azimuth adjustment of Section 4 are performed.
4. **Cue Detector(s) Sensitivity:** Test cartridge No. 2 is used to make adjustments as required. Refer to Section 8-3, 4, and 5 for these adjustments.
5. **Machine Speed Tests:** Test cartridge No. 3 is used for the periodic speed test. Insert this cartridge in the machine and measure the running time. If the running time is outside the 0.1% specification, refer to the mechanical adjustments in Section 4 and perform these as necessary to restore proper timing.

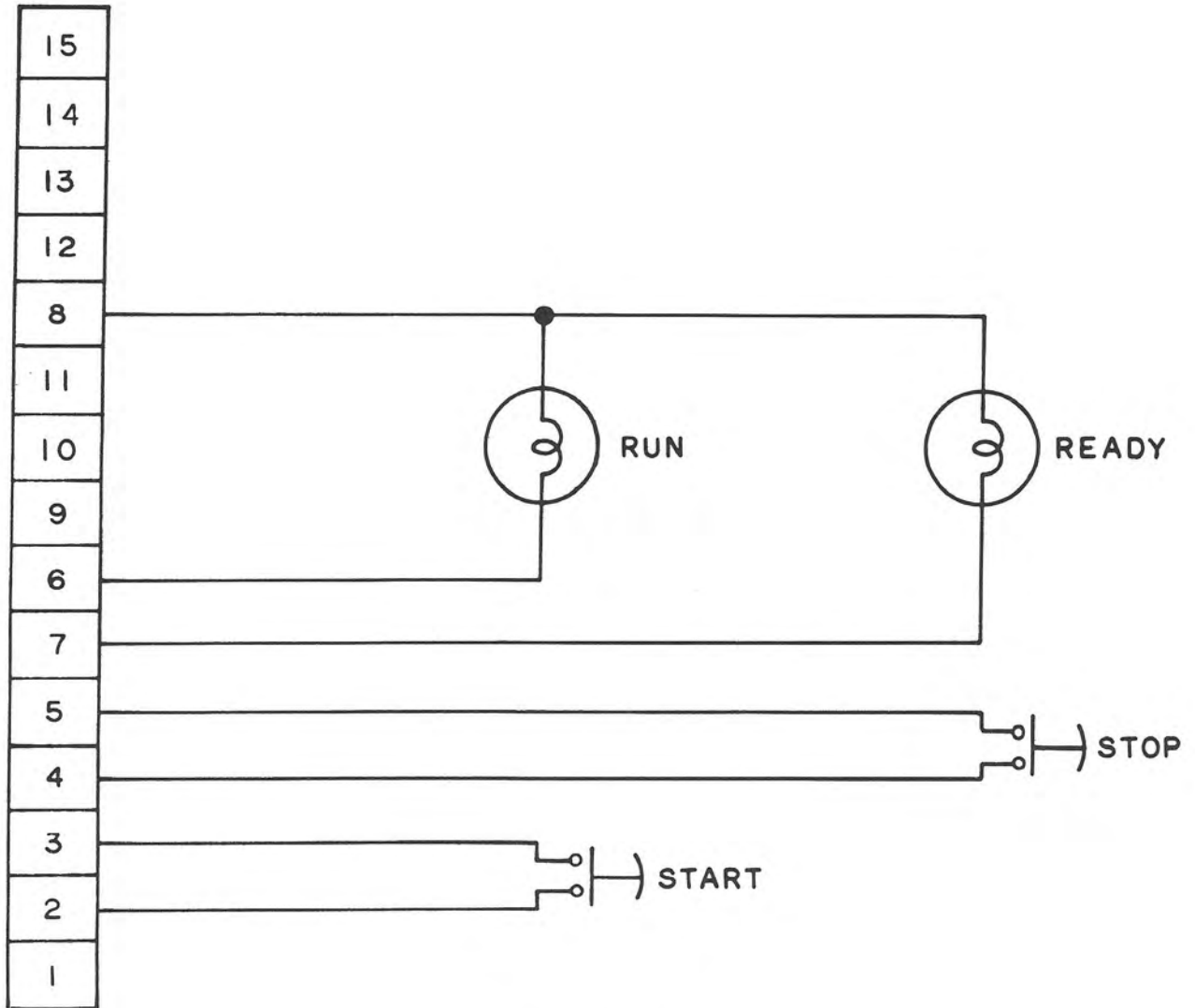

FIGURE 10-1

SAMPLE REMOTE CONTROL SCHEMATIC



# CUE DETECTOR CARD

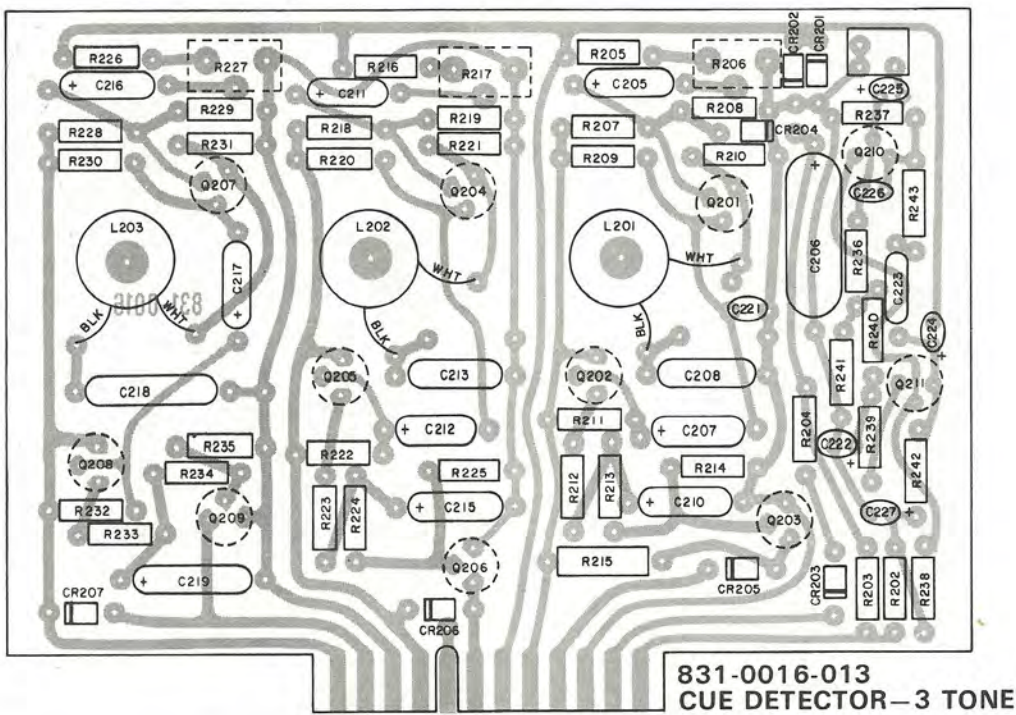
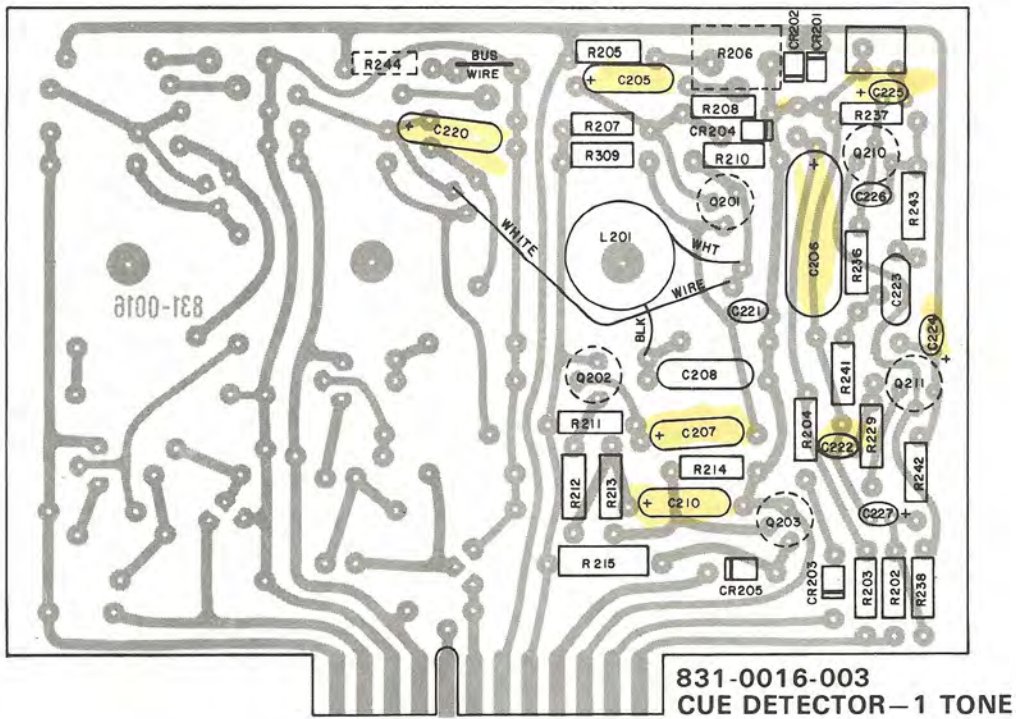

FIGURE 10-3



# PROGRAM AMPLIFIER CARD

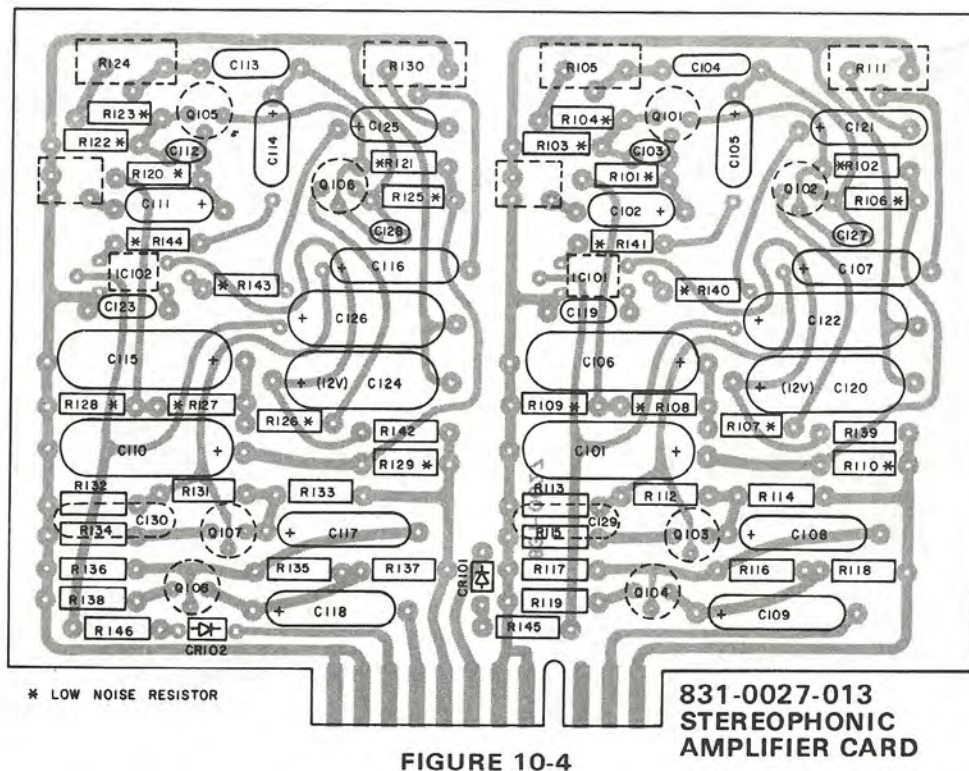
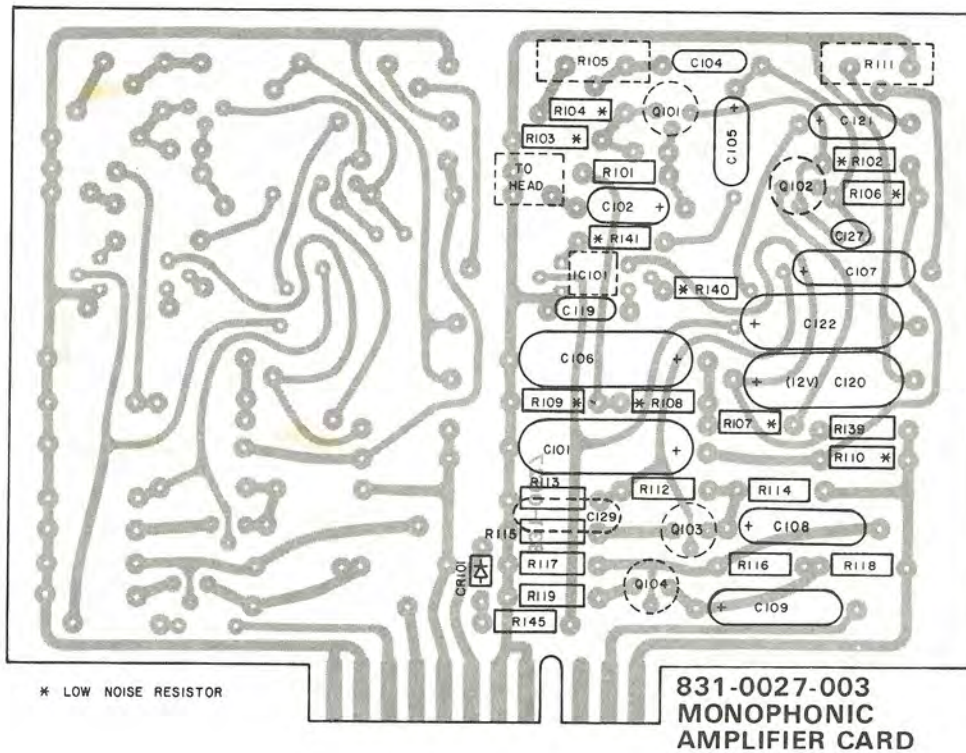

FIGURE 10-4

## SECTION XI

## ELECTRICAL PARTS LIST

## 3D SERIES REPRODUCER

## A. CHASSIS

Symbol	Part Number	Description
<b>FUSES</b>		
F1	417-0006-000	3/4 ampere, 3AG
F2	417-0002-000	1 ampere, slow-blow, 3AG
<b>LAMPS</b>		
I2 A,B,C	415-0001-000	# 327, 28 V
I3 A,B,C	415-0003-000	Cartridge, 28 V, yellow, Dialco 507-3918-1476-600
	263-0001-000	Clip, Retaining, for above lamp
<b>INTEGRATED CIRCUIT</b>		
IC1	605-0007-000	Series Regulated Power Supply, 25 VDC, 1 amp, Fairchild 7824 KC
<b>SOCKETS</b>		
J1 A,B,C	380-0004-000	15 pin (Control)
J2 A,B,C	380-0003-000	6 pin (Audio)
J4 A,B,C	380-0002-000	12 pin Card Edge (Program)
J5 A,B,C	280-0002-000	12 pin Card Edge (Cue)
J6	380-0011-000	20 pin (Interconnect to Recording Amp)
<b>RELAYS</b>		
K1 A,B,C	480-0001-000	4 PDT, 24 V (1 kHz, Control)
K2 A,B,C	580-0001-000	4 PDT, 24 V (150 Hz)
K3 A,B,C	480-0001-000	4 PDT, 24 V (8 kHz)
<b>INDUCTIVE DEVICES</b>		
L1 A,B,C	477-0006-002	Solenoid, 110 Volt DC
L2 A,B,C	504-0002-000	Head, Mono Reproduce, Nortronics PB2H7KNO
	504-0004-000	Head, Stereo Reproduce, Nortronics PB3Q7KNO
L3 A,B,C	504-0001-000	Head, Dummy, Nortronics H801016
	504-0003-000	Head, Mono Record, Nortronics PB2H4RNO (on "C" Deck only when used with a WRA Series Re- cording Amplifier)
	504-0005-000	Head, Stereo Record, Nortronics PB3Q4RNO (on "C" Deck only when used with a WRA Series Re- cording Amplifier)
<b>PLUGS</b>		
P1 A,B,C	378-0003-000	15 pin (Control)
P2 A,B,C	378-0002-000	6 pin (Audio)
P3	378-0001-000	3 pin (Motor)
<b>SWITCHES</b>		
S1 A,B,C	392-0001-000	Micro (Cartridge Sensing)
S2 A,B,C	391-0002-000	Push-Button (start) Dialco 513-0101-604
	404-0007-010	Lens for above, green, Dialco 303-3472, Engraved "START"
S3 A,B,C	391-0004-000	Switch, Push-Button (stop) Switchcraft 913
<b>TRANSFORMERS</b>		
T1	526-0002-000	Power (NT 1117)
T2 A,B,C	532-0001-010	Audio (NT 712)
T3 A,B,C	532-0001-010	Audio (NT712) (Stereo Only)
<b>CAPACITORS</b>		
C1	683-0001-000	1.5 mfd, 370 V, (for 60 Hz motor)
	683-0003-000	2.0 mfd, 370 V, (for 50 Hz motor)
C2 A,B,C	698-0003-000	100/100 mfd, 250 V

Symbol	Part Number	Description
C3	689-0001-000	1000 mfd, 50 V
C4 A	698-0001-000	1000 mfd, 50 V
C4 B,C	698-0004-000	1000/1000 mfd, 50 V
<b>MISCELLANEOUS</b>		
	507-0001-010	Head Lead Assembly, mono play
	507-0002-030	Head Lead Assembly, stereo play left
	507-0003-030	Head Lead Assembly, stereo play cue
	507-0004-030	Head Lead Assembly, stereo play right
	507-0001-000	Head Lead Assembly, mono record
	507-0002-030	Head Lead Assembly, stereo record left
	507-0003-030	Head Lead Assembly, stereo record cue
	507-0004-030	Head Lead Assembly, stereo record right
	433-0001-000	Cord, AC Power
	418-0001-000	Holder, Fuse
	487-0001-000	Sockets, relay
	613-0002-000	Socket, TO-3 Transistor (for IC1)
	831-0012-002	PC Card, Test Extender, 12 Conductor

## B. UTILITY CARD (831-0030-003)

<b>CAPACITORS</b>		
C5	696-0078-000	100 mf, 12 V
C13 A,B,C	696-0164-000	20 mf, 150 V
<b>RESISTORS</b>		
R1 A,B,C	628-0116-000	75 ohms, 5 watts, 5%
R3 A,B,C	626-0439-000	100 ohms, 1 watt, 10%
R4 A,B,C	626-0251-000	330 ohms, 1/2 watt, 5%
R5 A,B,C	630-0239-000	100 ohms, 1/2 watt, 5%
R6 A,B,C	630-0239-000	100 ohms, 1/2 watt, 5%
R7 A,B,C	626-0239-000	100 ohms, 1/2 watt, 5%
R8	626-0231-000	47 ohms, 1/2 watt, 5%
R9 A,B,C	628-0116-000	75 ohms, 5 watt, 5%
R17 A,B,C	626-0231-000	47 ohms, 1/2 watt, 5%
<b>DIODES</b>		
CR1	575-0007-000	IN4005
CR2	575-0007-000	IN4005
CR3	575-0007-000	IN4005
CR4	575-0007-000	IN4005
CR6	575-0007-000	IN4005
CR7	575-0007-000	IN4005
CR8 A,B,C	575-0007-000	IN4005
CR9	575-0007-000	IN4005

<b>MISCELLANEOUS</b>		
J3	380-0001-000	3 Pin motor socket, w/ clip

*451-00068-020*

**C. PROGRAM REPRODUCE AMPLIFIER CARD**  
**MONO 831-0027-003**  
**STEREO 831-0027-013**

<b>CAPACITORS</b>		
C101	696-0124-000	100 mfd, 25 V.
C102	696-0114-000	5 mfd, 25 V.
C103	677-0001-000	100 pfd, 300 V.
C104	681-0046-000	.01 mfd, 200 V.
C105	696-0114-000	5 mfd, 25 V.
C106	696-0124-000	100 mfd, 25 V.
C107	696-0117-000	10 mfd, 25 V.

Symbol	Part Number	Description	Symbol	Part Number	Description
C108	696-0117-000	10 mfd, 25 V.	R127	630-0283-000	6800 ohms, 1/2 watt, 5%, Lo Noise
C109	696-0117-000	10 mfd, 25 V.	R128	630-0269-000	1800 ohms, 1/2 watt, 5%, Lo Noise
C119	681-0032-000	.00068 mfd, 200 V.	R129	630-0293-000	18 K ohms, 1/2 watt, 5%, Lo Noise
C120	696-0202-000	450 mfd, 12 V.	R130	636-0002-000	Variable, 10 K ohms, 1/4 watt, (Right Level)
C121	696-0114-000	5 mfd, 25 V.	R131	626-0307-000	68 K ohms, 1/2 watt, 5%
C122	696-0122-000	50 mfd, 25 V.	R132	626-0287-000	10 K ohms, 1/2 watt, 5%
C127	677-0001-000	100 pfd, 300 V.	R133	626-0271-000	2.2 K ohms, 1/2 watt, 5%
C129	681-0050-000	.022 mfd, 200 V.	R134	626-0251-000	330 ohms, 1/2 watt, 5%

#### CAPACITORS (STEREO ONLY)

C110	696-0124-000	100 mfd, 25 V.
C111	696-0114-000	5 mfd, 25 V.
C112	677-0001-000	100 pfd, 300 V.
C113	681-0046-000	.01 mfd, 200 V.
C114	696-0114-000	5 mfd, 25 V.
C115	696-0124-000	100 mfd, 25 V.
C116	696-0117-000	10 mfd, 25 V.
C117	696-0117-000	10 mfd, 25 V.
C118	696-0117-000	10 mfd, 25 V.
C123	681-0032-000	.00068 mfd, 200 V.
C124	696-0202-000	450 mfd, 12 V.
C125	696-0114-000	5 mfd, 25 V.
C126	696-0122-000	50 mfd, 25 V.
C128	677-0001-000	100 pfd, 300 V.
C130	681-0050-000	.022 mfd, 200 V.

#### TRANSISTORS

Q101	590-0013-000	2N5089
Q102	590-0013-000	2N5089
Q103	590-0017-000	2N5816
Q104	590-0017-000	2N5816

#### TRANSISTORS (STEREO ONLY)

Q105	590-0013-000	2N5089
Q106	590-0013-000	2N5089
Q107	590-0017-000	2N5816
Q108	590-0017-000	2N5816

#### RESISTORS

R101	626-0311-000	100 K ohms, 1/2 watt, 5%
R102	630-0311-000	100 K ohms, 1/2 watt, 5%, Lo Noise
R103	630-0249-000	100 ohms, 1/2 watt, 5%, Lo Noise
R104	626-0275-000	3.3 K ohms, 1/2 watt, 5%
R105	636-0002-000	Variable, 10 K ohms, 1/4 watt, (L. Equalization)
R106	630-0287-000	10 K ohms, 1/2 watt, 5%, Lo Noise
R107	630-0259-000	680 ohms, 1/2 watt, 5%, Lo Noise
R108	630-0283-000	6800 ohms, 1/2 watt, 5%, Lo Noise
R109	630-0267-000	1500 ohms, 1/2 watt, 5%, Lo Noise
R110	630-0295-000	22 K ohms, 1/2 watt, 5%, Lo Noise
	630-0293-000	18 K ohms, 1/2 watt, 5%, Lo Noise (STEREO ONLY)
R111	636-0002-000	Variable, 10 K ohms, 1/4 watt, (L. Level)
R112	626-0307-000	68 K ohms, 1/2 watt, 5%
R113	626-0287-000	10 K ohms, 1/2 watt, 5%
R114	626-0271-000	2.2 K ohms, 1/2 watt, 5%
R115	626-0251-000	330 ohms, 1/2 watt, 5%
R116	626-0295-000	22 K ohms, 1/2 watt, 5%
R117	626-0279-000	4700 ohms, 1/2 watt, 5%
R118	626-0259-000	680 ohms, 1/2 watt, 5%
R119	626-0231-000	47 ohms, 1/2 watt, 5%
R139	626-0263-000	1 K ohms, 1/2 watt, 5%
R140	626-0271-000	2.2 K ohms, 1/2 watt, 5%
R141	626-0303-000	47 K ohms, 1/2 watt, 5%
R145	626-0267-000	1500 ohms, 1/2 watt, 5%

#### RESISTORS (STEREO ONLY)

R120	626-0311-000	100 K ohms, 1/2 watt, 5%
R121	630-0311-000	100 K ohms, 1/2 watt, 5%, Lo Noise
R122	630-0249-000	100 ohms, 1/2 watt, 5%, Lo Noise
R123	626-0275-000	3.3 K ohms, 1/2 watt, 5%
R124	636-0002-000	Variable, 10 K ohms, 1/4 watt, (Right Equal)
R125	630-0287-000	10 K ohms, 1/2 watt, 5%, Lo Noise
R126	630-0259-000	680 ohms, 1/2 watt, 5%, Lo Noise

R127	630-0283-000	6800 ohms, 1/2 watt, 5%, Lo Noise
R128	630-0269-000	1800 ohms, 1/2 watt, 5%, Lo Noise
R129	630-0293-000	18 K ohms, 1/2 watt, 5%, Lo Noise
R130	636-0002-000	Variable, 10 K ohms, 1/4 watt, (Right Level)
R131	626-0307-000	68 K ohms, 1/2 watt, 5%
R132	626-0287-000	10 K ohms, 1/2 watt, 5%
R133	626-0271-000	2.2 K ohms, 1/2 watt, 5%
R134	626-0251-000	330 ohms, 1/2 watt, 5%
R135	626-0295-000	22 K ohms, 1/2 watt, 5%
R136	626-0279-000	4700 ohms, 1/2 watt, 5%
R137	626-0259-000	680 ohms, 1/2 watt, 5%
R138	626-0231-000	47 ohms, 1/2 watt, 5%
R142	626-0263-000	1 K ohms, 1/2 watt, 5%
R143	626-0271-000	2.2 K ohms, 1/2 watt, 5%
R144	626-0303-000	47 K ohms, 1/2 watt, 5%
R146	626-0267-000	1500 ohms, 1/2 watt, 5%

#### MISCELLANEOUS

IC101	606-0003-000	MFC 6040
IC102	606-0003-000	MFC 6040 (Stereo Only)
CR101	575-0007-000	IN4005
CR102	575-0007-000	IN4005 (Stereo Only)

### D. CUE TONE DETECTOR CARD

**1 TONE 831-0016-003**  
**3 TONE 831-0016-013**

#### CAPACITORS

C205	696-0114-000	5 mfd, 25 V.
C206	696-0124-000	100 mfd, 25 V.
C207	696-0114-000	5 mfd, 25 V.
C208	681-0054-000	.047 mfd, 200 V.
C209		Selected to tune the detector to 1 kHz.
C210	696-0114-000	5 mfd, 25 V.
C211	696-0114-000	5 mfd, 25 V. (8 kHz)
C212	696-0114-000	5 mfd, 25 V. (8 kHz)
C213	681-0081-000	.015 mfd, 200 V. (8 kHz)
C214		Selected to tune the detector to 8 kHz.
C215	696-0110-000	1 mfd, 25 V. (8 kHz)
C216	696-0114-000	5 mfd, 25 V. (150 Hz)
C217	696-0114-000	5 mfd, 25 V. (150 Hz)
C218	685-0003-000	2.2 mfd, 250 V. (150 Hz)
C219	696-0117-000	10 mfd, 25 V. (150 Hz)
C220	696-0114-000	5 mfd, 25 V. (1 kHz only) Single Tone
C221	686-0002-000	.025 mfd, 100 V.
C222	694-0002-000	10 mfd, 20 V.
C223	681-0046-000	.01 mfd, 200 V.
C224	694-0003-000	4.7 mfd, 35 V.
C225	694-0004-000	.47 mfd, 35 V.
C226	677-0001-000	100 pfd, 300 V.
C227	694-0002-000	10 mfd, 20 V.

#### DIODES

CR201	575-0002-000	IN462
CR202	575-0002-000	IN462
CR203	575-0007-000	IN4005
CR204	575-0007-000	IN4005
CR205	575-0007-000	IN4005
CR206	575-0007-000	IN4005 (Three Tone Only)
CR207	575-0007-000	IN4005 (Three Tone Only)

#### INDUCTORS

L201	511-0002-000	Toroid, 500 mh
L202	511-0005-000	Toroid, 20 mh (8 kHz)
L203	511-0002-000	Toroid, 500 mh (150 Hz)

#### TRANSISTORS

Q201	590-0001-000	2N3053
Q202	590-0014-000	2N2905
Q203	590-0001-000	2N3053
Q204	590-0001-000	2N3053 (8 kHz)
Q205	590-0014-000	2N2905
Q206	590-0001-000	2N3053 (8 kHz)

Symbol	Part Number	Description
Q207	590-0001-000	2N3053 (150 Hz)
Q208	590-0014-000	2N2905 (150 Hz)
Q209	590-0001-000	2N3053 (150 Hz)
Q210	590-0011-000	2N930
Q211	590-0011-000	2N930

### RESISTORS

R202	626-0255-000	470 ohms, ½ watt, 5%
R203	626-0283-000	68 K ohms, ½ watt, 5%
R204	626-0239-000	100 ohms, ½ watt, 5%
R205	626-0263-000	1 K ohms, ½ watt, 5%
R206	636-0002-000	Variable, 10 K ohms, ¼ watt (1 kHz sensitivity)
R207	626-0291-000	15 K ohms, ½ watt, 5%
R208	626-0291-000	15 K ohms, ½ watt, 5%
R209	626-0275-000	3.3 K ohms, ½ watt, 5%
R210	626-0279-000	4.7 K ohms, ½ watt, 5%
R211	626-0271-000	2.2 K ohms, ½ watt, 5%
R212	626-0263-000	1 K ohms, ½ watt, 5%
R213	626-0279-000	4.7 K ohms, ½ watt, 5%
R214	626-0279-000	4.7 K ohms, ½ watt, 5%
R215	626-0448-000	240 ohms, 1 watt, 10%
R216	626-0291-000	15 K ohms, ½ watt, 5%
R217	636-0002-000	Variable, 10 K ohms, ¼ watt (8 kHz sensitivity)
R218	626-0291-000	15 K ohms, ½ watt, 5% (8 kHz)
R219	626-0291-000	15 K ohms, ½ watt, 5% (8 kHz)
R220	626-0275-000	3.3 K ohms, ½ watt, 5% (8 kHz)
R221	626-0279-000	4.7 K ohms, ½ watt, 5% (8 kHz)
R222	626-0271-000	2.2 K ohms, ½ watt, 5% (8 kHz)
R223	626-0263-000	1 K ohms, ½ watt, 5% (8 kHz)
R224	626-0279-000	4.7 ohms, ½ watt, 5% (8 kHz)
R225	626-0279-000	4.7 K ohms, ½ watt, 5% (8 kHz)
R226	626-0239-000	100 ohms, ½ watt, 5% (150 Hz)
R227	636-0002-000	Variable, 10 K ohms, ¼ watt (150 Hz sensitivity)
R228	626-0291-000	15 K ohms, ½ watt, 5% (150 Hz)
R229	626-0291-000	15 K ohms, ½ watt, 5% (150 Hz)
R230	626-0275-000	3.3 K ohms, ½ watt, 5% (150 Hz)
R231	626-0279-000	4.7 K ohms, ½ watt, 5% (150 Hz)
R232	626-0271-000	2.2 K ohms, ½ watt, 5% (150 Hz)
R233	626-0263-000	1 K ohms, ½ watt, 5% (150 Hz)
R234	626-0279-000	4.7 K ohms, ½ watt, 5% (150 Hz)
R235	626-0279-000	4.7 K ohms, ½ watt, 5% (150 Hz)
R236	626-0311-000	100 K ohms, ½ watt, 5%
R237	626-0235-000	68 ohms, ½ watt, 5%
R238	626-0287-000	10 K ohms, ½ watt, 5%
R239	626-0239-000	100 ohms, ½ watt, 5%
R240	626-0271-000	2.2 K ohms, ½ watt, 5%
R241	626-0259-000	680 ohms, ½ watt, 5%
R242	626-0271-000	2.2 K ohms, ½ watt, 5%
R243	626-0303-000	47 K ohms, ½ watt, 5%
R244	626-0287-000	10 K ohms, ½ watt, 5% (single tone only)

## SECTION XII

### MAINTENANCE SCHEDULE

### 3D SERIES REPRODUCER

#### A. GENERAL

International Tapetronics has designed the 3D Series Reproducer with reliability and minimum maintenance as primary design goals. Simplicity and mechanical strength is an important factor in reducing mechanical maintenance. Electronic dependability is provided through the use of negative feedback and other techniques which stabilize circuits which are subjected to widely varying ambient conditions.

#### B. MECHANICAL MAINTENANCE

1. Weekly Maintenance:
  - a. Clean the capstan and pressure roller with a cloth dipped in alcohol. Remove all traces of lubricant and oxide from both the capstan and pressure roller.
  - b. Clean the head with a cotton swab dipped in a head cleaning solution.
2. Monthly Maintenance:
  - a. Check speed of unit. Since the capstan motor is a 450 RPM, direct drive, hysteresis synchronous device, there are no belts, pulleys, or flywheel assembly to cause speed variables. The bearings in this motor are permanently sealed ball bearings which need no lubrication.

Any effort to lubricate the motor bearings will result in oil seeping into the motor windings.

To check the speed of the unit, play test cartridge No. 4 (see Section IX). The playing time should not vary more than .4 seconds in 3½ minutes. If a frequency counter is available, the 12 kHz tone should not vary more than 24 Hz.

- b. Check the pressure roller using an ITC pressure roller gauge 830-0006-001.
- c. Check head alignment.
- d. The 3D Reproducer requires no lubrication.

#### C. ELECTRICAL MAINTENANCE

The electrical maintenance is recommended monthly and includes measuring electrical parameters and making corrective adjustments if required.

Using the test cartridges and procedures outlined in Section IX, check the cue sensitivity, program play level and equalization. Should the 3-D be used in conjunction with a WRA recording amplifier, refer to the WRA instruction manual for electrical recording maintenance.

## **SECTION XIII**

### **WARRANTY**

International Tapetronics Corporation (ITC) warrants to Purchaser that the equipment sold is free of defects of workmanship or material and conforms to the specifications referred to or set out herein. This warranty, applying only to the original user, extends from date of shipment for a period of two years. No claim shall be maintained hereunder unless written notice is received by Seller within thirty days after the discovery of the facts giving rise to the claim. The sole or exclusive liability of Seller for breach of warranty shall be to refund the purchase price of the item sold, or at its option, to replace or repair the item or part concerned FOB its factory, or such other place as it may designate. ITC's liability shall arise only if Purchaser causes the defective part or item to be delivered to ITC for inspection upon ITC's request at Purchaser's expense. This warranty shall not be effective if the alleged defect is due to maltreatment, exposure, excessive moisture or any other use of the equipment other than the use for which the manufacturer prescribed.

No warranties expressed or implied shall be applicable to any equipment sold hereunder, and the foregoing shall constitute the Buyer's sole right and remedy under the agreements in this paragraph contained. In no event shall International Tapetronics Corporation have any liability for consequential damages, or for loss, damage, or expense directly or indirectly arising from the use of the products, or any inability to use them either separate or in combination with other equipment or materials, or from any other cause.

ITC's warranty is given solely to the original user and only to the extent above described. No dealer or agent is authorized to make any other or additional guaranty or warranty.

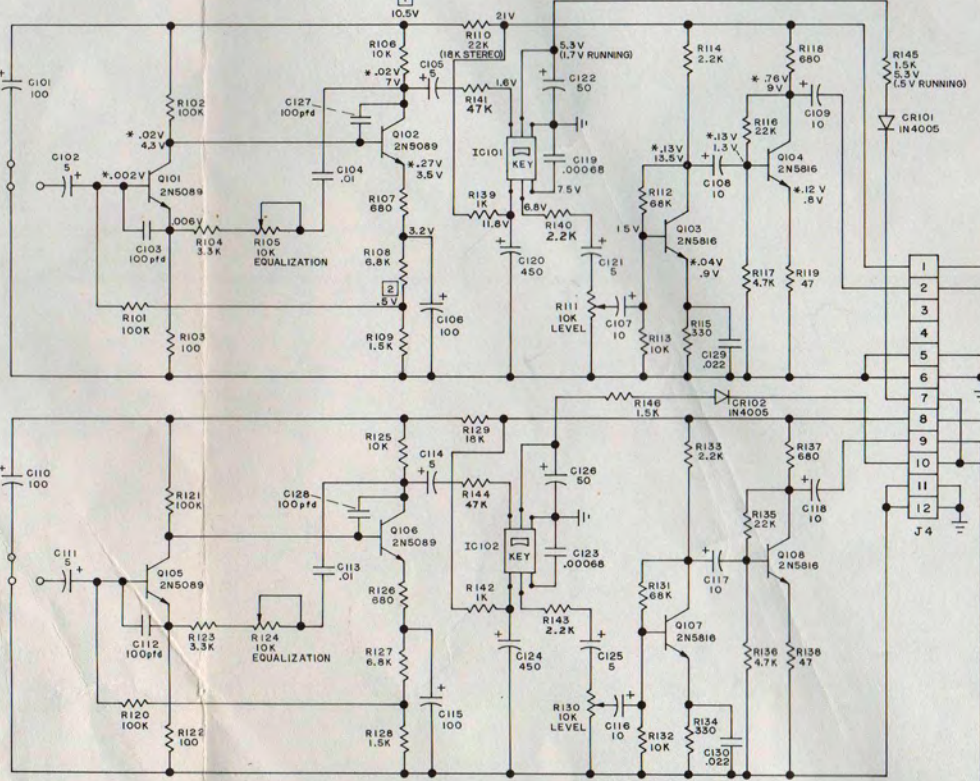
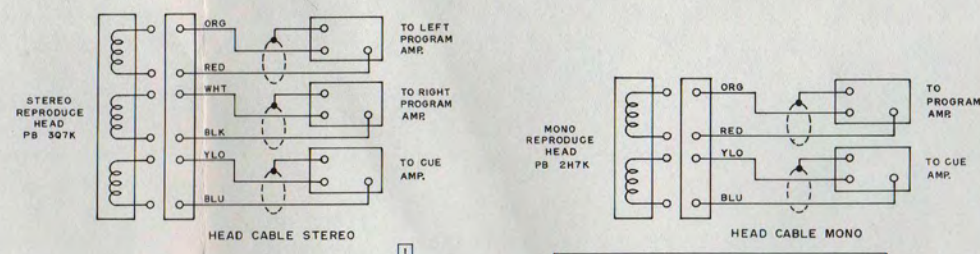

- NOTES:**
1. ALL RESISTORS 1/2 W. UNLESS OTHERWISE SPECIFIED.
  2. ALL CAPACITORS SHOWN IN MICROFARADS UNLESS OTHERWISE SPECIFIED.
  3. POWER LIGHT MAY BE REPLACED WITH POWER SWITCH—INSERT SWITCH AT POINT X.
  4. NORMALLY WIRED FOR 600Ω OUTPUT—FOR 150Ω, REPLACE ORANGE WIRE WITH YELLOW WIRE.
  5. FUSE HOLDERS, RELAY, TRANSISTOR AND IC SOCKETS NOT SHOWN ON SCHEMATIC.
  6. ALL POINTS MARKED → ARE CONNECTED TOGETHER AND ARE AT +25V.
  7. SWITCH IS JUMPERED AT FACTORY. CUT FOR INTERRUPTED MOTOR OPERATION.
- ▲ C220 CAPACITOR USED ON 1KHz CUE BOARDS ONLY.
8. VALUES OF COMPONENTS ARE TYPICAL. SCHEMATICS ARE INTENDED TO BE AS ACCURATE AS POSSIBLE. HOWEVER, AS NECESSARY, COMPONENTS ARE SUBSTITUTED WITH EQUIVALENT STANDARD VALUES, OR AS REQUIRED, TO INSURE PROPER OPERATION AND CALIBRATION.

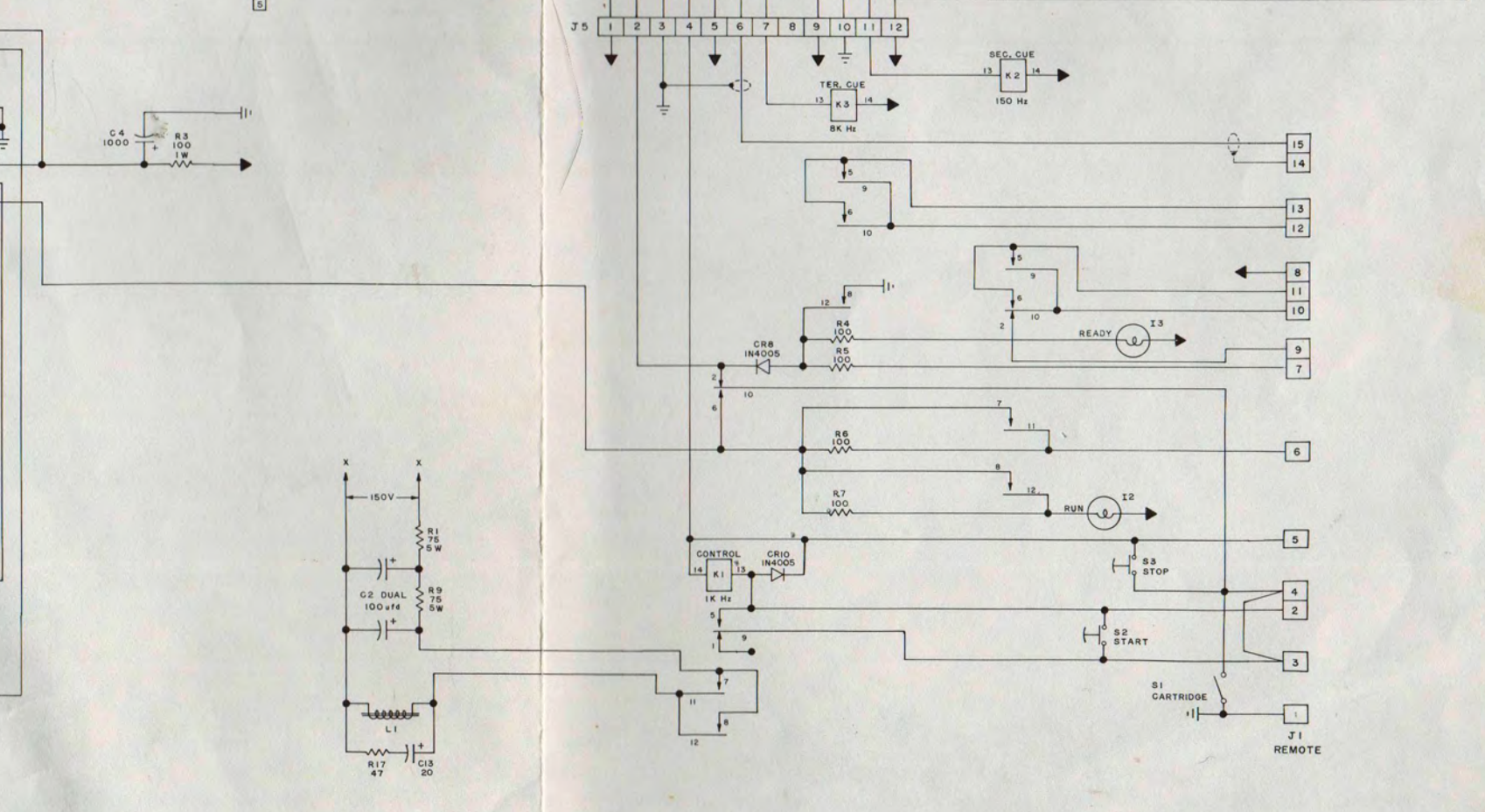
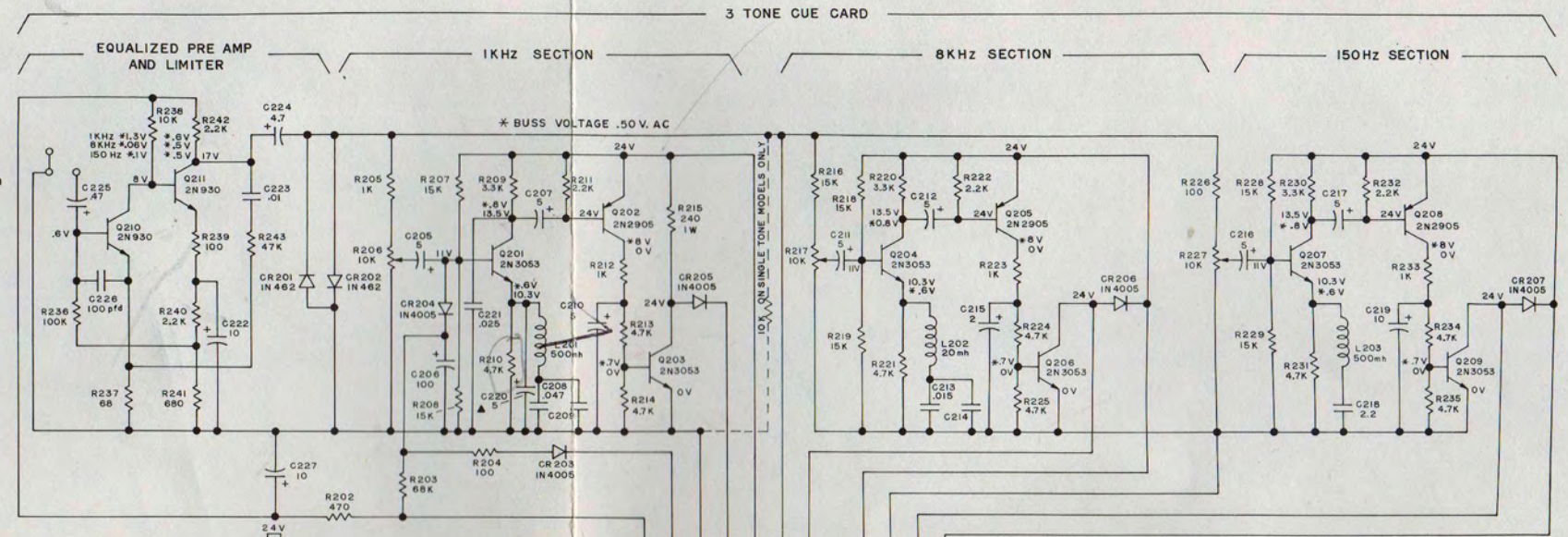
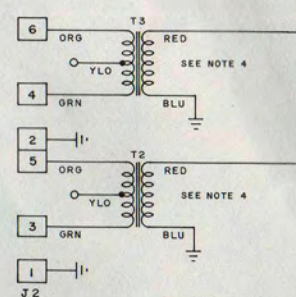

If You Didn't Get This From My Site,  
Then It Was Stolen From...  
[www.SteamPoweredRadio.Com](http://www.SteamPoweredRadio.Com)

TITLE		SCHEMATIC, 3D SERIES A & B DECKS	
INTERNATIONAL TAPETRONICS CORPORATION	893-0063-005	DRAWING NUMBER	REV
BLOOMINGTON, ILLINOIS 61701			

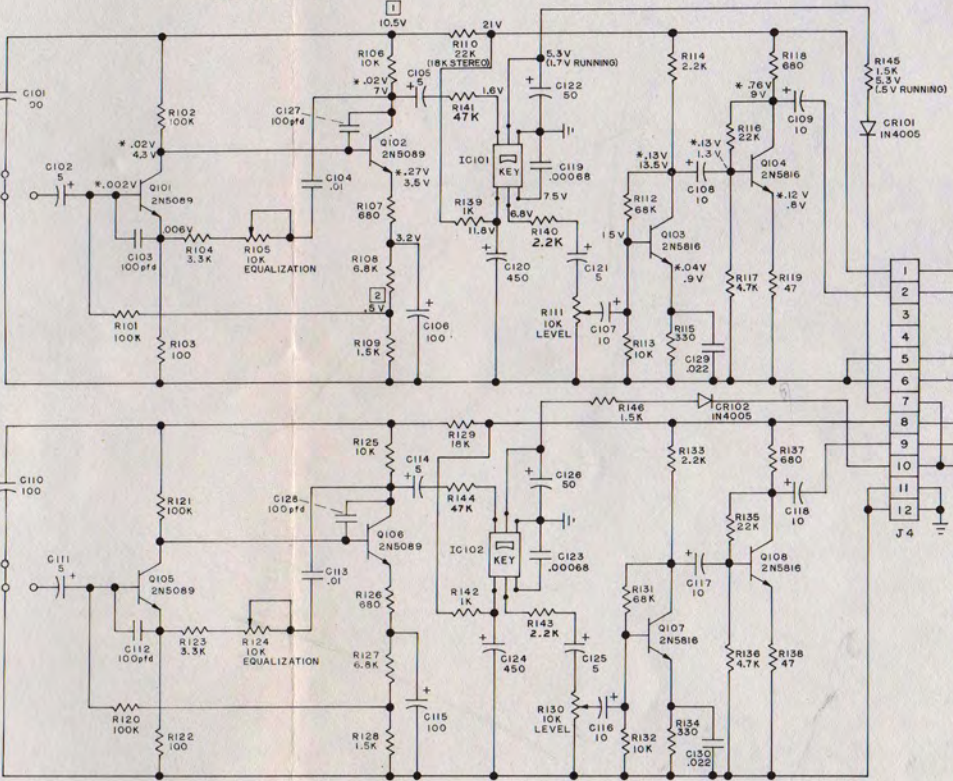
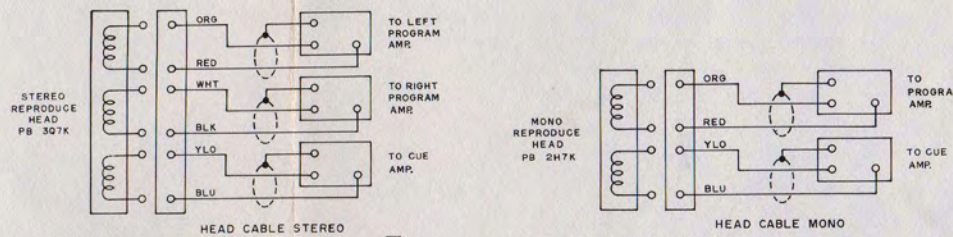

- NOTES:**
1. ALL RESISTORS 1/2 W. UNLESS OTHERWISE SPECIFIED.
  2. ALL CAPACITORS SHOWN IN MICROFARADS UNLESS OTHERWISE SPECIFIED.
  3. POWER LIGHT MAY BE REPLACED WITH POWER SWITCH—INSERT SWITCH AT POINT X.
  4. NORMALLY WIRED FOR 600Ω OUTPUT—FOR 150Ω, REPLACE ORANGE WIRE WITH YELLOW WIRE.
  5. FUSE HOLDERS, RELAY, TRANSISTOR AND IC SOCKETS NOT SHOWN ON SCHEMATIC.
  6. ALL POINTS MARKED → ARE CONNECTED TOGETHER AND ARE AT +25V.
  7. SWITCH IS JUMPED AT FACTORY. CUT FOR INTERRUPTED MOTOR OPERATION.
- ▲ C220 CAPACITOR USED ON 1KHz CUE BOARDS ONLY.
8. VALUES OF COMPONENTS ARE TYPICAL. SCHEMATICS ARE INTENDED TO BE AS ACCURATE AS POSSIBLE. HOWEVER, AS NECESSARY, COMPONENTS ARE SUBSTITUTED WITH EQUIVALENT STANDARD VALUES, OR AS REQUIRED, TO INSURE PROPER OPERATION AND CALIBRATION.

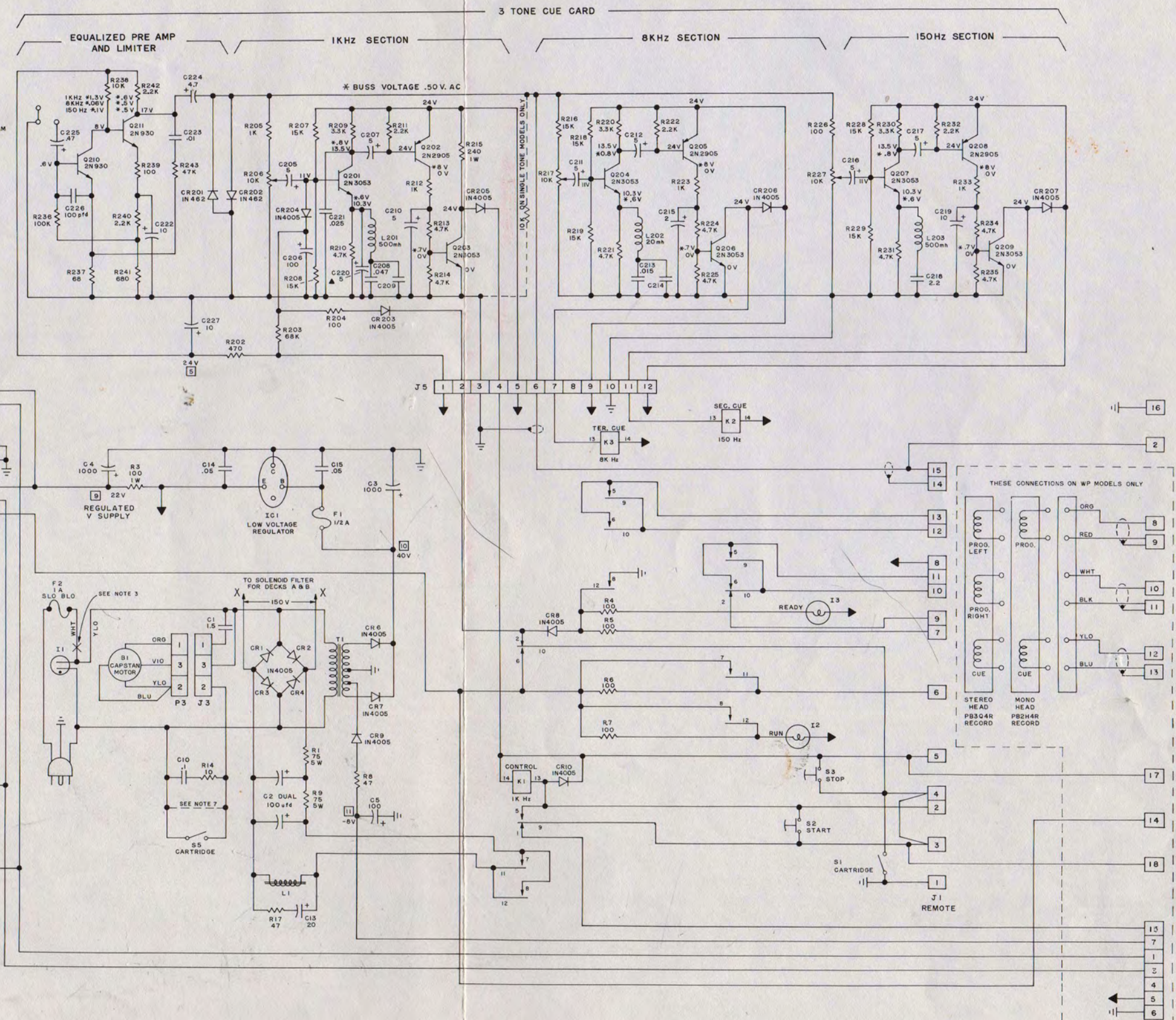
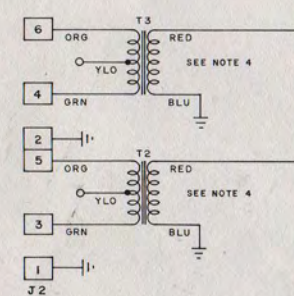

If You Didn't Get This From My Site,  
Then It Was Stolen From...  
[www.SteamPoweredRadio.Com](http://www.SteamPoweredRadio.Com)

TITLE	
SCHEMATIC, 3D SERIES LOWER DECK (C)	
INTERNATIONAL TAPETRONICS CORPORATION	893-0062-005
BLOOMINGTON, ILLINOIS 61701	DRAWING NUMBER REV

INTER-CONNECTS  
WITH RECORDER  
P302