

Serial No. 1991

April 1953



**OPERATING AND MAINTENANCE
INSTRUCTION**

for

**TYPE 1931-A
AMPLITUDE-MODULATION
MONITOR**

FORM 639-D
F.C.C. APPROVAL NO. 1555



GENERAL RADIO COMPANY

CAMBRIDGE 39

MASSACHUSETTS

If You Didn't Get This From My Site,
Then It Was Stolen From...

www.SteamPoweredRadio.com

TABLE OF CONTENTS

	<i>Page</i>
INTRODUCTION	1
SECTION 1 — INSTALLATION	1
1.1 Input Coupling	1
1.2 Coupling to Transmitter	2
1.3 Power Supply	2
1.33 Rear Connections	2
SECTION 2 — OPERATION	3
2.1 Procedure	3
2.2 Distortion and Noise Measurements	3
2.3 Program Level Monitoring	3
2.4 Transmitter Audio-Frequency Response	4
SECTION 3 — CIRCUIT DETAILS	4
SPECIFICATIONS	5
SERVICE AND MAINTENANCE NOTES	6
VACUUM TUBE DATA	8

**OPERATING AND MAINTENANCE
INSTRUCTIONS**

for

**TYPE 1931-A
AMPLITUDE-MODULATION
MONITOR**



GENERAL RADIO COMPANY

CAMBRIDGE 39

MASSACHUSETTS

FORM 639-D



Manufactured and sold under the following United States Letters Patent owned by the General Radio Company or under license grants from other companies:

2,069,934
1,999,869

2,012,291
2,298,177

Patents of the American Telephone and Telegraph Company.

OPERATING INSTRUCTIONS FOR TYPE 1931-A AMPLITUDE-MODULATION MONITOR

INTRODUCTION

The Type 1931-A Amplitude Modulation Monitor is designed for monitoring the modulation percentage of A-M transmitters. It gives (1) a continuous indication of either positive or negative modulation peaks, as selected by a panel switch, and (2) a visual indication of negative peaks in excess of a predetermined level which is set by means of a dial on the panel, and (3) an indication of the relative magnitude of any shift in average carrier amplitude which may occur during modulation.

Two low-distortion audio-frequency output cir-

cuits are provided. One of these can be matched directly to a 600-ohm line and is useful for audio-frequency monitoring. The other is intended for use with the Type 1932-A Distortion and Noise Meter for measuring overall transmitter distortion and carrier noise.

The percentage-modulation meter carries an auxiliary db scale, and hence the monitor can be used for program-level monitoring.

Overall audio-frequency response can also be measured with this monitor.

SECTION 1.0 INSTALLATION

1.1 INPUT COUPLING

1.11 Two sets of input tuning coils are available to cover the carrier-frequency range. One set, consisting of the Type 1931-P5-1 Tuning Coil and the Type 1931-P5-2 Coupling Coil, covers the 0.5-to-8 Mc portion of the range. The other set, consisting of the Type 1931-P6-1 Tuning Coil and the Type 1931-P6-2 Coupling Coil, covers the 3-to-60 Mc portion of the range.

1.12 The tuning coil of each set cover its portion of the range in four steps as selected by the setting of a connecting strap on the coil.

1.13 The frequency range for each of the four steps is indicated by engraved numerals adjacent to a terminal on the tuning coil.

1.14 When the Type 1931-P6-1 Tuning Coil is used, the connecting strap must connect the central terminal of the coil to the terminal for the desired frequency range.

1.15 When the Type 1931-P5-1 Tuning Coil is used, the triangular connector provided with the coil must connect the central terminal to either one or two of the other terminals, depending on its position, and must be oriented so that the arrow on the connector points to the terminal for the desired frequency range.

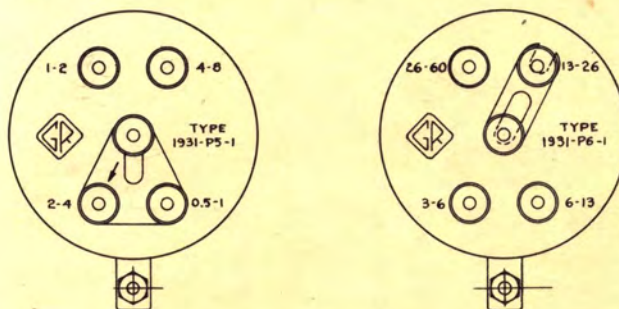

Figure 1. Range-selecting terminals for input tuning coils.

GENERAL RADIO COMPANY

1.16 The set of coils provided with the MONITOR can easily be removed and replaced with the set for the other frequency range.

1.17 The coupling coil of a set is mounted with two screws on the mounting block of the carrier control shaft.

1.18 The tuning coil is mounted with two thumb nuts on the brackets either side of the shaft. A plug on the tuning coil must be inserted in a corresponding jack on the instrument.

1.19 Sideband clipping varies directly with tuning capacity. While sideband clipping will in any event be less than 0.5 db for modulating frequencies below 15 kilocycles, it is advantageous to use the lower tuning capacitance when there is a choice because of overlap in coil ranges.

1.2 COUPLING TO TRANSMITTER

1.21 This instrument has been designed to operate from the standard R.M.A. Monitor-Output connection, which will provide an output of 10 volts into a load of 75 ohms. For those transmitters not provided with a Monitor-Output connection the most convenient way to couple the Type 1931-A Modulation Monitor to the transmitter is to install a small coil of a very few turns close to the antenna lead or to the tank circuit. This coil is then connected to the monitor input terminals. An ordinary rubber-insulated single-conductor concentric cable of around 75 ohms impedance has been found convenient. This forms a low-impedance link circuit with the coil mounted in the monitor.

1.22 Sufficient coupling must be provided so that when the instrument is turned on, the CARRIER meter can be SET TO 100 after the signal has been tuned to resonance by means of the TUNE FOR MAXIMUM control. Some margin in the setting of the carrier SET TO 100 control knob must be allowed to compensate for changes in the trans-

mitter output or in the coupling system. The TUNE FOR MAXIMUM control must be very carefully set to resonance to avoid sideband clipping.

1.23 The tuned circuit in the instrument is damped by two 10,000-ohm resistors in parallel. If one of the resistors is removed, somewhat less power will be required to operate the instrument, but sideband clipping will be increased, although not to a serious extent. At the higher carrier frequencies, these load resistors may be removed without increasing side-band clipping appreciably.

1.3 POWER SUPPLY

1.31 The instrument can be operated from any 115/230 volt, 50-60 cycle line. Connections on the power transformer enable the input to be changed from 115 to 230 volts, if required. See Figure 2, below, for connection data. The power supply name-plate is reversible, and should be turned over if the transformer connections are changed.

1.32 Internal voltage regulators permit stable operation of the instrument over a range of 105-125 (110-250) volts.

1.33 **Rear Connections:** The connector furnished with the instrument must be plugged into the rear Jones socket in order to obtain readings on the Percentage Modulation Meter. The electrical circuit is completed by a connection between terminals No. 7 and No. 10. If a remote meter is used, remove this connection and add the external meter circuit between terminals No. 7 and N. 8. (The external impedance thus added should be 700 ohms \pm 20%.)

1.34 The 600-ohm audio monitoring output is available at terminals No. 11 and No. 12. **NOTE:** No. 12 terminal is grounded, and should connect to the external line shield. This circuit cannot be used

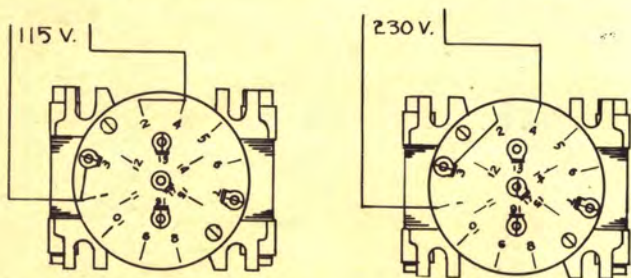

Figure 2. Power transformer connections for 115 volts and 230 volts.

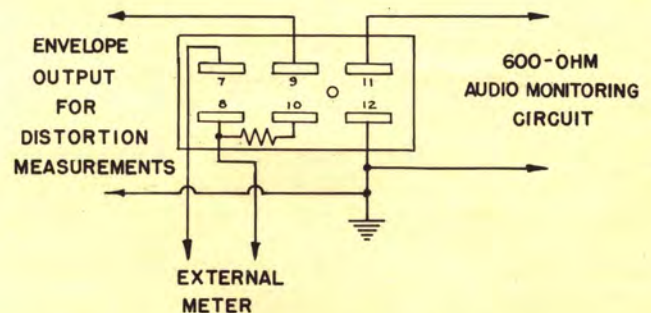

Figure 3. Rear connections.

GENERAL RADIO COMPANY

with balanced lines, but must be operated with one side grounded.

1.35 Terminal No. 9 is the audio output to be used with the Type 1932-A Distortion and Noise Meter, only.

SECTION 2.0 OPERATION

2.1 PROCEDURE

2.11 Turn on power switch.

2.12 With the power on and no carrier applied, the carrier meter should read zero. The mechanical adjustment should be used, if necessary.

2.13 With power on and no carrier applied the percentage modulation meter should read zero. The mechanical adjustment on the meter may be used to bring it to zero. This check can be made when the carrier input is applied to the instrument, if the carrier is unmodulated. If this is done, be sure the modulation due to noise is not sufficient to deflect the meter.

2.14 With the carrier applied but with no modulation, TUNE FOR MAXIMUM reading of the CARRIER meter. For this adjustment, the SET TO 100 carrier control should be set back sufficiently so that the meter reading does not exceed 100. After the instrument has been tuned for resonance, the SET TO 100 control may be advanced to obtain a reading of 100 on the meter. Retune if necessary. With the circuit correctly tuned to resonance and with the meter reading 100, all direct-reading scales are standardized. When modulation is applied, any shift in average carrier amplitude may be read directly in percent on the CARRIER meter.

2.15 If the transmitter is now modulated, the PERCENTAGE MODULATION meter will read the instantaneous percentage modulation, and readings for either positive or negative peaks can be obtained by means of the PEAKS switch.

2.16 The MODULATION PEAKS dial can be set at the maximum value of percentage modulation at which it is desired to operate, and the OVER MODULATION lamp will flash whenever this percentage is exceeded. The lamp operates on negative peaks.

2.2 DISTORTION AND NOISE MEASUREMENTS

2.21 When the Type 1932-A Distortion and Noise Meter is used with the monitor, an intercon-

necting shielded cable is supplied. This is clearly marked with the instrument type numbers on either end, to identify the proper positions. When the instruments are installed in a relay rack, with the 1931-A above the 1932-A, this cable will be found to fit easily in place.

2.22 It is important that the MODULATION PEAKS dial be set at approximately the modulation level indicated on the PERCENTAGE MODULATION meter, when these measurements are made. If the dial is not set in this manner, distortion readings obtained on the Type 1932-A Distortion and Noise Meter may be slightly high.

2.23 If the dial is set too far below the actual percentage modulation, distortion at the higher audio frequencies will be introduced by excessive reactance loading of the diode rectifier.

2.24 If the dial is set above the actual percentage modulation, the voltage input to the Type 1932-A may be too low to permit normal operation of the latter, but no increase of distortion will result.

2.25 In any case, an error in setting of this dial will in no way affect the readings of the Type 1931-A Amplitude-Modulation Monitor.

2.26 **Precautions** — Because of the extremely low noise level which these instruments are capable of reading, certain precautions must be observed if full advantages are to be realized. Operation of these instruments in the presence of strong external electromagnetic fields is not advisable. Sufficient shielding has been provided for most conditions normally encountered. Some trouble may occur from power-frequency sources, giving rise to hum pickup. Good grounding, and reversing one, or both, of the power connecting cords has been found helpful in certain cases.

2.3 PROGRAM LEVEL MONITORING

2.31 The movements of the percentage modulation indicator furnish an indication of instantaneous level that is useful for monitoring. This meter does not give a VU indication, because its ballistics must

GENERAL RADIO COMPANY

conform to specifications for modulation monitors as established by the FCC.

2.4 TRANSMITTER AUDIO-FREQUENCY RESPONSE

2.41 By applying a voltage of variable audio fre-

quency to the audio-frequency input circuits of the transmitter, and reading the db scale on the percentage modulation meter for each frequency setting, the overall a-f response of the transmitter can be determined.

SECTION 3.0 CIRCUIT DETAILS

3.1 The input circuit to the monitor consists of a low-impedance coupling coil L-4 coupled to a tuned circuit consisting of L-3 and C-1. The resistors R-1 and R-2 load this circuit sufficiently to eliminate sideband clipping over the operating range of the monitor.

3.2 The voltage developed across the tuned circuit is then applied to the double diode V-1. One of the diodes feeds the monitoring circuit, the other provides an essentially distortionless reproduction of the r-f envelope for distortion measurements.

3.3 The modulation meter diode is followed by an r-f filter consisting mainly of the choke L-5 which removes all the r-f components, leaving only a negative d-c component which is proportional to the average carrier level and an a-c component which is proportional to the varying envelope of the original modulated carrier. Relative carrier level is indicated by a d-c meter in series with the diode rectifier.

3.4 For the indicating meter circuit, the a-c component is linearly amplified and applied to a peak response half-wave diode voltmeter. The diode can be reversed in polarity by means of a panel switch so that either positive or negative peaks can be measured.

A highly stable degenerative d-c amplifier follows the diode and includes the d-c indicating meter. The meter has a high-speed response characteristic to meet FCC specifications for this type of monitor.

3.5 For the warning-lamp circuit, the a-c component is applied directly to the grid of an amplifier tube. Any given percentage of the negative d-c component is chosen by the setting of a potentiometer, which is calibrated 0-100% modulation. Whenever the a-c component exceeds the negative d-c component, the amplifier tube operates to trigger a thyratron tube. A warning lamp connected in the anode circuit flashes, indicating the presence of a modulation peak in excess of the dial setting.

3.6 The other section of the double diode V-1 is used to supply a distortionless envelope output for distortion measurements with the Type 1932-A Distortion and Noise Meter. The diode is followed by an r-f filter and a voltage divider which is ganged with the MODULATION PEAKS control. This output is available at the multipoint connector at the rear of the instrument and is indicated on the elementary schematic diagram as ENVELOPE OUTPUT.

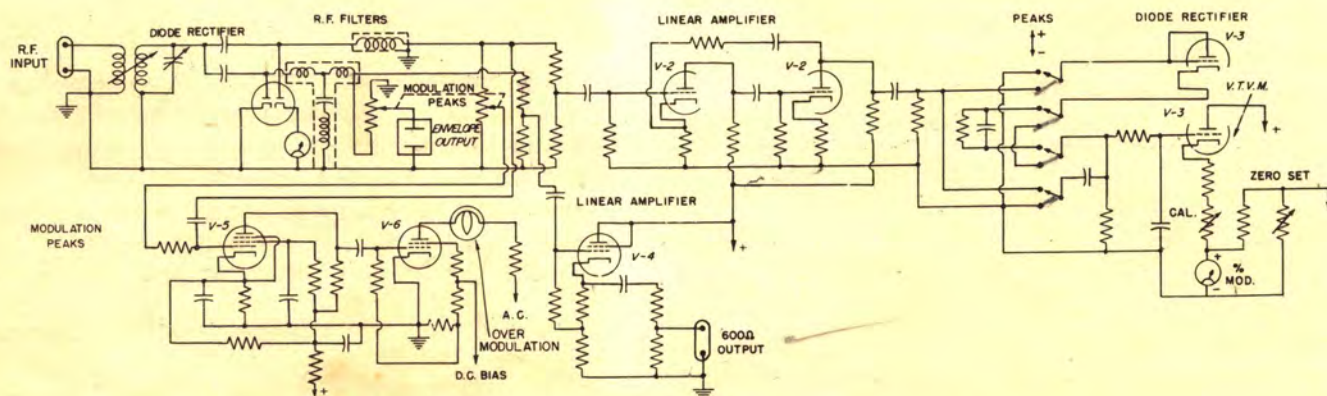

Figure 4. Elementary schematic circuit diagram.

GENERAL RADIO COMPANY

3.7 The use of separate diodes for modulation measurements and distortion measurements isolates the two instruments electrically and prevents any inter-action between them which might otherwise affect the accuracy of measurement. A high-fidelity audio output operating from the same diode that is used for distortion measurements is also provided for audio-frequency monitoring purposes. The output of this amplifier is independent of all panel controls, and can be loaded without causing any reaction

Range: Modulation percentage, 0 to 110%, indicated by meter on positive peaks, 0 to 100% on negative peaks. The flashing lamp is adjustable to operate from 0 to 100% on negative peaks.

Carrier-Frequency Range: The monitor will operate at any carrier frequency from 0.5 to 60 megacycles. A single set of coils (either 0.5 to 8 megacycles or 3 to 60 megacycles) is supplied with each instrument, unless both sets are specifically ordered.

Carrier-Frequency Input Impedance: About 75 ohms in the broadcast band, increasing slightly at higher carrier frequencies and varying somewhat with input tuning.

Accuracy: The overall accuracy of measurement at 400 cycles is $\pm 2\%$ of full scale at 0% and 100%, and $\pm 4\%$ of full scale at any other percentage.

Detector Linearity: The distortion in the diode detector is very low for frequencies up to 7500 cycles. Above this frequency, a small amount of negative peak clipping occurs, reaching 5% at the extreme high end of the audio range at 15,000 cycles and 100% modulation.

Audio-Frequency Response: The frequency response of the meter indication is constant within ± 0.25 db between 30 and 15,000 cycles.

R-F Power: In the broadcast range the maximum r-f power requirement is about 0.5 watt.

Vacuum Tubes: The following tubes are used:

2—type 6SN7-GT	1—type 2050
2—type 6SJ7	2—type OD3/VR150
1—type 6AL5	1—type 6X5

Warning Lamp Circuit: The OVERMODULATION lamp will flash whenever the negative modulation peaks exceed the setting of the MODULATION PEAKS dial by approximately 2% modulation, for audio frequencies between 30 and 7500 cycles. For higher audio frequencies, the percentage overmodulation required to flash increases slightly. The accuracy of the dial calibration is approximately $\pm 2\%$.

upon other circuits in the monitor. The internal impedance is approximately 600 ohms. This output is available at the rear for permanent cable connections and also at Western Electric panel jacks. Plugging into the panel jacks automatically disconnects the plug at the rear.

3.8 All indicating meters are of the Weston, Model 891, illuminated type. Connections at the rear of the instrument provide for connecting a remote percentage modulation meter, if desired.

Meter Circuit: The response of the PERCENTAGE MODULATION meter circuit is flat, within ± 0.1 db, between 50 and 15,000 cycles.

Either positive or negative modulation peaks may be read to an accuracy of $\pm 2\%$ at 0 and 100% modulation. At other modulation levels, the possible error increases to a maximum of $\pm 4\%$. Calibration in db below 100% modulation is also provided.

The meter movement meets FCC specifications for modulation monitors.

Audio Monitoring Output: The audio output amplifier is flat, to within ± 1.0 db, from 30 to 45,000 cycles. The internal impedance is 600 ohms. Distortion is less than 0.2%. Open-circuit output voltage is about 300 millivolts.

Fidelity-Measuring Output: Flat within ± 1.0 db between 30-15,000 cycles with TYPE 1932-A Distortion and Noise Meter connected.

Output level varies inversely with setting of MODULATION PEAKS dial, thus providing reasonably uniform input to distortion meter at all modulation levels. Average output level, approximately 1.5 volts between 15 and 100% modulation.

Residual noise and hum level is below -80 db.

Auxiliary Output: A multipoint connector at the rear of the instrument provides a means of connecting:

1. A remote Percentage Modulation Meter.
2. Line for 600-ohm monitoring.
3. The TYPE 1932-A Distortion and Noise Meter.

Power Supply: 105 to 125 volts, 50 to 60 cycles. Power input is approximately 50 watts.

Accessories Supplied: Spare pilot lamps and fuses, multipoint connector, 7-foot connecting cord, one TYPE 274-M Plug, and one set of input tuning coils (specify frequency range desired).

Mounting: The instrument is relay-rack mounted. Walnut end frames are available for table mounting.

Dimensions: Panel (length) 19 x (height) $8\frac{3}{4}$ inches. Depth behind panel, 10 inches.

Net Weight: 31 pounds.

SERVICE AND MAINTENANCE NOTES FOR THE TYPE 1931-A AMPLITUDE-MODULATION MONITOR

1.0 FOREWORD

1.1 This Service Information together with the information given in the Operating Instructions should enable the user to locate and correct ordinary difficulties resulting from normal usage.

1.2 Most of the components mentioned in these notes can be located by referring to the photographs.

1.3 Major service problems should be referred to the Service Department, which will co-operate as far as possible by furnishing information and instructions, as well as by shipping any replacement parts which may be required. If the instrument is more than one year old, a reasonable charge may be expected for replacement parts or for complete reconditioning and recalibration if the monitor is returned.

1.4 Detailed facts giving type and serial numbers of the instrument and parts, as well as operating conditions, should always be included in your report to the Service Department.

If the monitor becomes inoperative, a few simple checks should be made before removing the instrument from the cabinet.

2.0 GENERAL

2.1 Check power line source.

2.2 Test power supply cord for open circuit or poor contact in power outlet and in the receptacle at the rear of the monitor.

2.3 Check fuses mounted at back of the monitor for open circuits and be sure they are tight in their clips.

2.4 Make certain that the ground on the monitor is at the same potential as the transmitter frame.

2.5 Check coupling to the transmitter.

2.6 Check transmitter coupling cable and make certain that the losses are not excessive.

2.7 CAUTION: Adjustment R-18 is set at the factory and should not be disturbed.

3.0 MODULATION MONITOR INOPERATIVE

3.1 See that all tube filaments are lighted. Test also the line filter condensers for open or short circuits.

3.2 Check pilot light and meter lamps. These lamps are operated at reduced voltage to prolong life.

3.3 If the CARRIER meter does not read, see Section 5.0.

3.4 If the OVER MODULATION lamp does not flash or flashes erratically, see Section 8.0.

3.5 If the % MODULATION meter does not read or does not agree with the OVER MODULATION lamp, see Section 13.0.

4.0 ERRATIC OPERATION OF POWER SUPPLY

4.1 If V-8 and V-9 do not glow there is insufficient plate voltage. Check V-7 as well as V-8 and V-9. Refer to tube voltage, Section 18.0. Partial shorts across the plate supply may drop the voltage below the operating point.

4.2 If there is poor plate voltage regulation against line voltage changes, try new V-8 and V-9.

4.3 If pilot light or meter lights do not operate, check fuses F-1 and F-2.

4.31 If fuses blow, check line connections to power transformer T-1.

4.4 Check C-12, C-19, C-20, C-21, C-23, C-24, C-25 and C-26.

5.0 NO READING OF CARRIER METER

5.1 Improper coupling of instrument to the transmitter.

5.2 Defective meter. This should read full scale with 400 microamperes d-c applied.

5.21 If the meter is defective, a replacement should be ordered from the Service Department.

ment. The General Radio Company cannot assume responsibility for any local repairs to the meter, although such repairs might be necessary in an emergency.

5.3 Open or short circuit in either input coil.

5.4 Improper setting of TUNE FOR MAXIMUM control.

5.5 Defective V-1 Tube (6AL5).

6.0 LOW READING OF CARRIER METER

6.1 Insufficient r-f input.

6.2 Improper tuning of input.

6.3 Losses in coupling line.

6.4 Improper range connection in input coil.

6.5 Defective V-1 tube (6AL5).

6.6 Open R-3.

6.7 Open R-3 potentiometer. (Front section of MODULATION PEAKS double potentiometer.)

7.0 HIGH READING OF CARRIER METER

7.1 Too much coupling.

7.2 Open R-1 and/ or R-2.

8.0 OVER MODULATION LAMP FAILS TO FLASH

8.1 Refer to Sections 5.0, 6.0, and 7.0.

8.2 Defective lamp, or lamp is loose in its socket.

8.21 The lamp may be checked by shorting No. 3 terminal of V-6 tube to ground. It will flash if P-3 lamp is normal, and R-40 is not open.

8.22 Check voltage from T-1 No. 10 terminal to ground. This should be 160 volts ac. (T-1 No. 9 terminal should be grounded.)

8.3 Check V-5 (6SJ7) and V-6 (2050) flash tube.

8.4 L-5 open circuited.

8.5 MODULATION PEAKS potentiometer (R-3) open circuited at grounded end.

8.6 R-30 and/ or R-31 open.

8.7 Check resistors and capacitors in OVER MODULATION circuit.

9.0 OVER MODULATION LAMP FLASHES ERRATICALLY

9.1 Refer to previous sections.

9.2 Loose in socket.

9.3 Refer to Section 8.2.

9.4 Poor contact or loose arm on the shaft of R-3.

9.5 Deteriorating V-6 (2050).

10.0 OVER MODULATION LAMP REMAINS LIGHTED REGARDLESS OF SETTINGS

10.1 Refer to previous sections.

10.3 If the voltage across C-30 is less than 6 volts d-c, V-7 (6X5GT) rectifier is defective.

10.4 R-3 open circuited.

10.5 Defective C-30.

10.6 The voltage across R-26 should be 2 volts d-c.

10.7 R-33 set incorrectly.

11.0 FAILURE OF OVER MODULATION LAMP TO FLASH AT ANY SETTING OF MODULATION PEAKS POTENTIOMETER

11.1 Refer to Section 10.0.

12.0 MODULATION PEAKS SETTING DISAGREES WITH OVER MODULATION LAMP AND/OR % MODULATION METER

12.1 Loose dial in R-3.

12.2 R-33 out of adjustment.

12.21 Assuming that % MODULATION meter and OVER MODULATION lamp operate satisfactorily, set PEAKS switch at NEG. Set MODULATION PEAKS dial to 80, adjust R-33 so that the lamp is just out but lights between 80% and 82%, as indicated on % MODULATION meter.

12.3 Defective PEAKS switch.

12.4 Refer to % MODULATION circuit.

12.5 Set the mechanical zero of % MODULATION meter to zero. This is done with the instrument turned off.

12.6 Check electrical zero of % MODULATION meter. This is done with the instrument operating, without modulation applied, and with no hum modulation of carrier. Adjust electrical zero by means of R-20. (Refer to Section 15.0.)

GENERAL RADIO COMPANY

13.0 FAILURE OF % MODULATION METER TO READ, BUT CARRIER METER READS NORMALLY

13.1 Follow procedure outlined in all previous sections.

13.2 Make certain that the Jones plug or inter-connecting plug (if a Type 1932-A Distortion and Noise Meter is used) are plugged in properly.

13.3 See that there is a connection soldered between terminals 7 and 10 in external Jones plug (SO-1).

13.4 Defective meter. This should read full scale with 600 microamperes d-c applied.

13.41 Refer to Section 5.21.

13.5 Defective tubes V-2 and/ or V-3 (6SN7GT).

13.6 Defective R-18 and R-20.

13.7 Defective or poor contact in PEAKS switch.

13.8 Defective R-5 through R-12, inclusive, resistors.

14.0 % MODULATION METER READING ERRATICALLY

14.1 Follow procedure outlined in all previous paragraphs.

14.2 Defective tubes V-2 and V-3.

14.3 Defective PEAKS switch.

14.4 Loose contacts in external circuit, if remote meter is used.

15.0 % MODULATION METER ELECTRICAL ZERO ADJUSTMENT

15.1 Refer to Section 12.6.

15.2 V-2 and V-3, if replaced, should be of the same manufacture.

15.3 Defective R-20.

16.0 NO OUTPUT FROM AUDIO OUTPUT 600 ohm

16.1 Check tube V-4 (6SJ7).

16.2 Check contacts in J-1 and J-2 output, jack receptacles.

16.3 Refer to Sections 1.0 through 6.0.

17.0 CLEANING AND LUBRICATION

17.1 Use a solution of half ether and half alcohol to clean the contact surface of the winding of R-3 and R-48. **CAUTION:** This fluid is highly inflammable, and care should be exercised in using it. Clean residue with lint free cloth. A thin smear of clock oil should be applied to the contact surface of the winding.

17.2 Crocus cloth is recommended for cleaning the contacts of the AUDIO OUTPUT jacks.

18.0 VACUUM TUBE DATA

Table of tube voltages measured between socket terminals using a 20,000 ohm per volt meter (Weston 772 Analyzer). D-C voltages except as noted might vary $\pm 20\%$.

SYMBOL	TYPE	PLATE NO. 1	SCREEN	CATHODE NO. 1	FILAMENT	GRID NO. 1	PLATE NO. 2	CATHODE NO. 2	GRID NO. 2	SUPPRESSOR GRID	SHIELD	ANODE	FUNCTION
V-1	6AL5	2-5 0		5-G 0	3-4 6.3 AC		7-1 .3	1-G 0					Diode Rectifier
V-2	6SN7GT	5-6 100		6-G 12.5	7-8 6.3 AC	4-6 1.0	2-3 115	3-G 13.5	1-3 2.5				Linear Amplifier
V-3	6SN7GT	5-6 .75		6-G 10.7	7-8 6.3 AC	4-6 .75	2-3 250	3-G 23	1-3 8				Rectifier and VTVM
V-4	6SJ7	8-5 96	6-5 96	5-G 160	2-7 6.3 AC	4-5 .5				3-5 96			Linear Amplifier
V-5	6SJ7	8-5 26	6-5 26	5-G 1.8	2-7 6.3 AC	4-5 .3				3-5 0			Voltage Amplifier
V-6	2050	3-8 160 AC		8-G 0	2-7 6.3 AC	5-8 1.0					6-8 .7		Thyratron
V-7	6X5	3-G 310 AC		8-G 350 DC	2-7 6.3 AC		5-G 310 AC						Rectifier
V-8	OD3/VR150											5-2 150	Regulator
V-9	OD3/VR150											5-2 150	Regulator

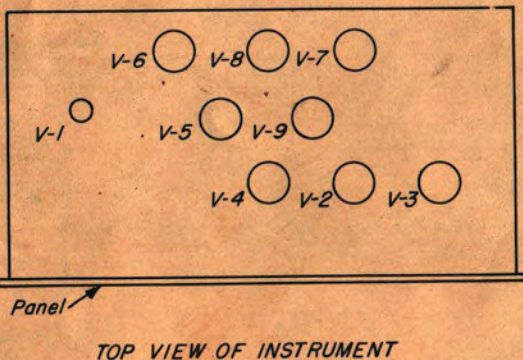
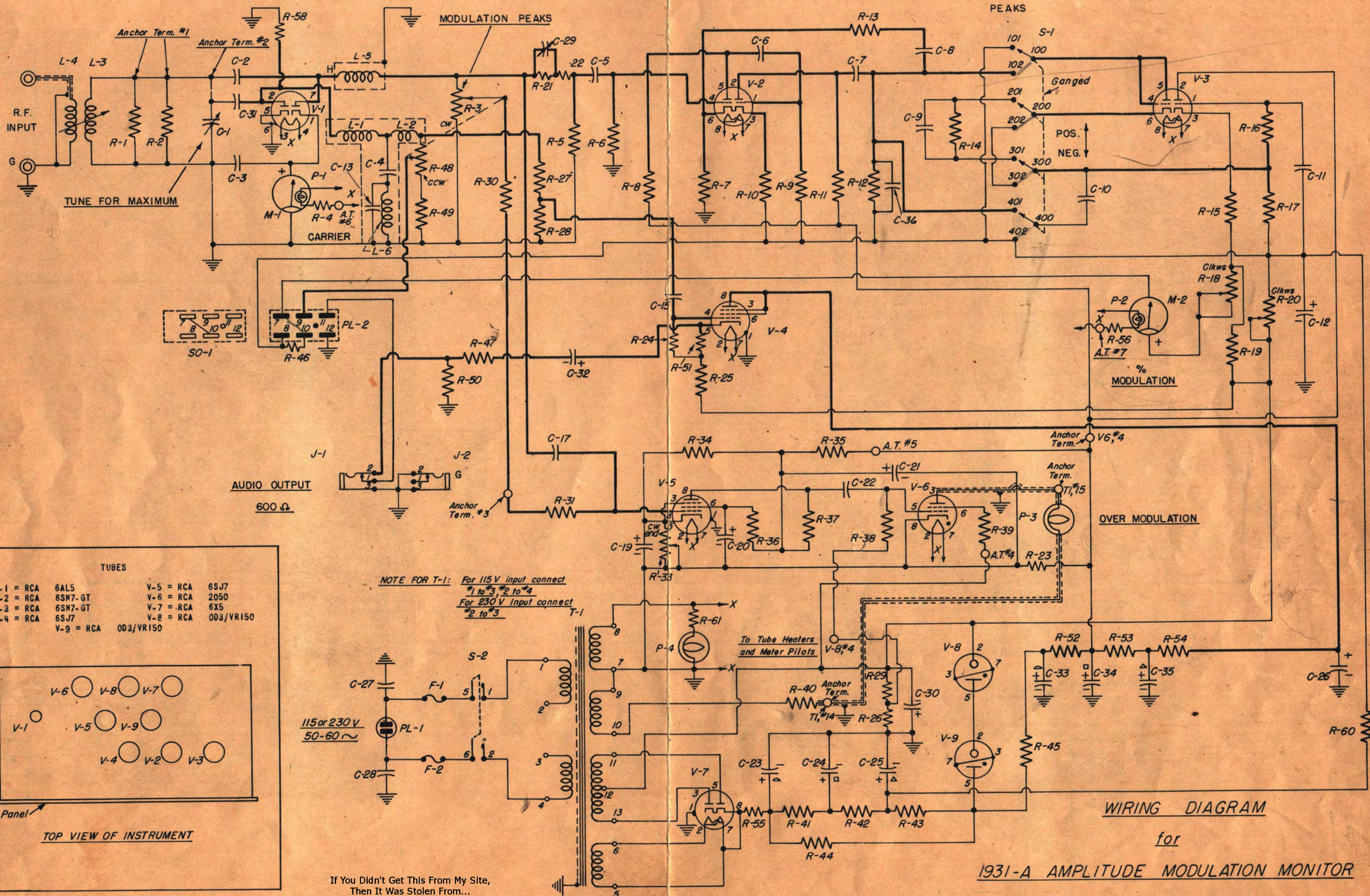

If You Didn't Get This From My Site,
Then It Was Stolen From...
www.SteamPoweredRadio.Com

1931-A AMPLITUDE MODULATION MONITOR

Figure 5. Complete wiring diagram and tube layout.

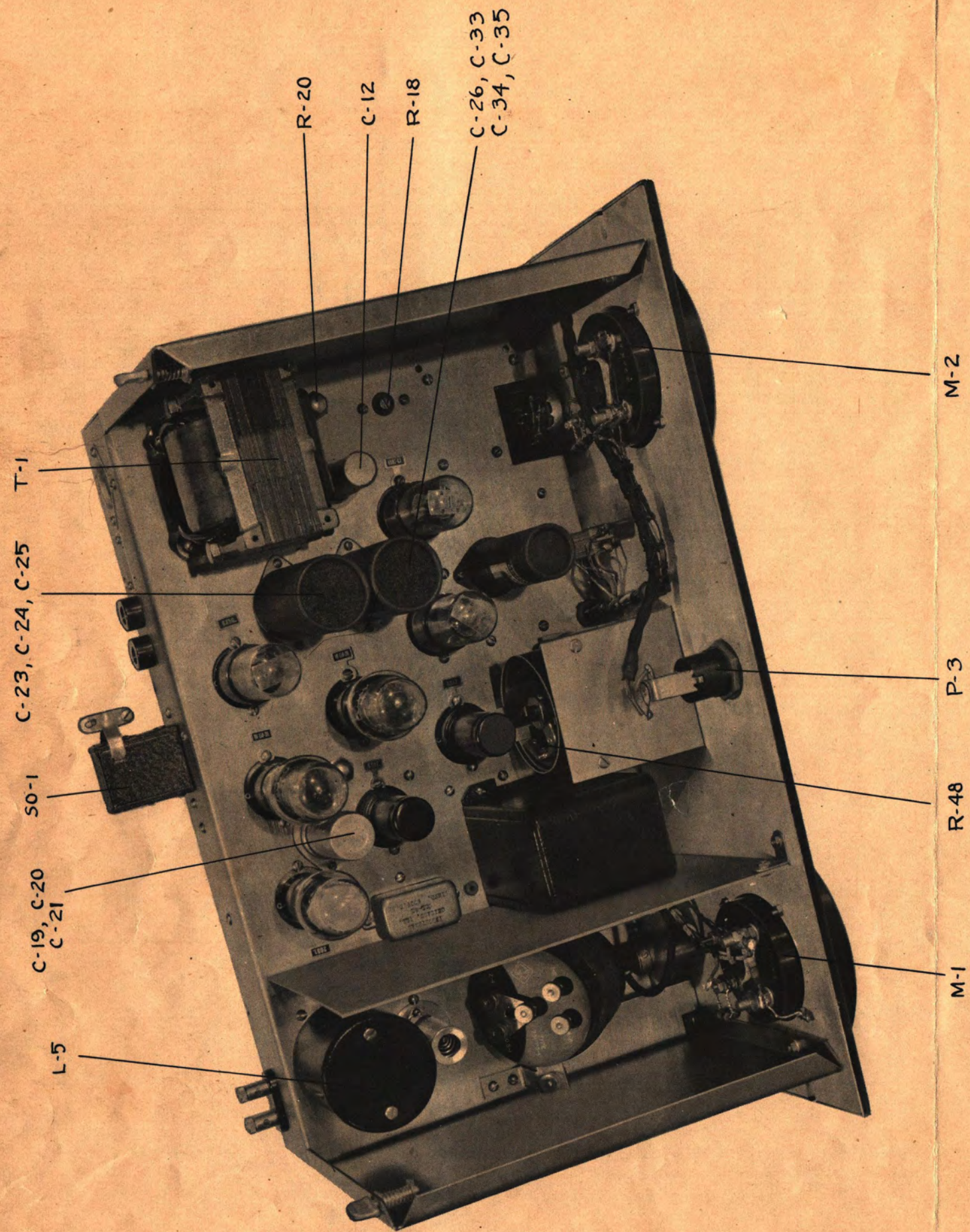

Figure 6. Interior view of chassis with main circuit components identified.

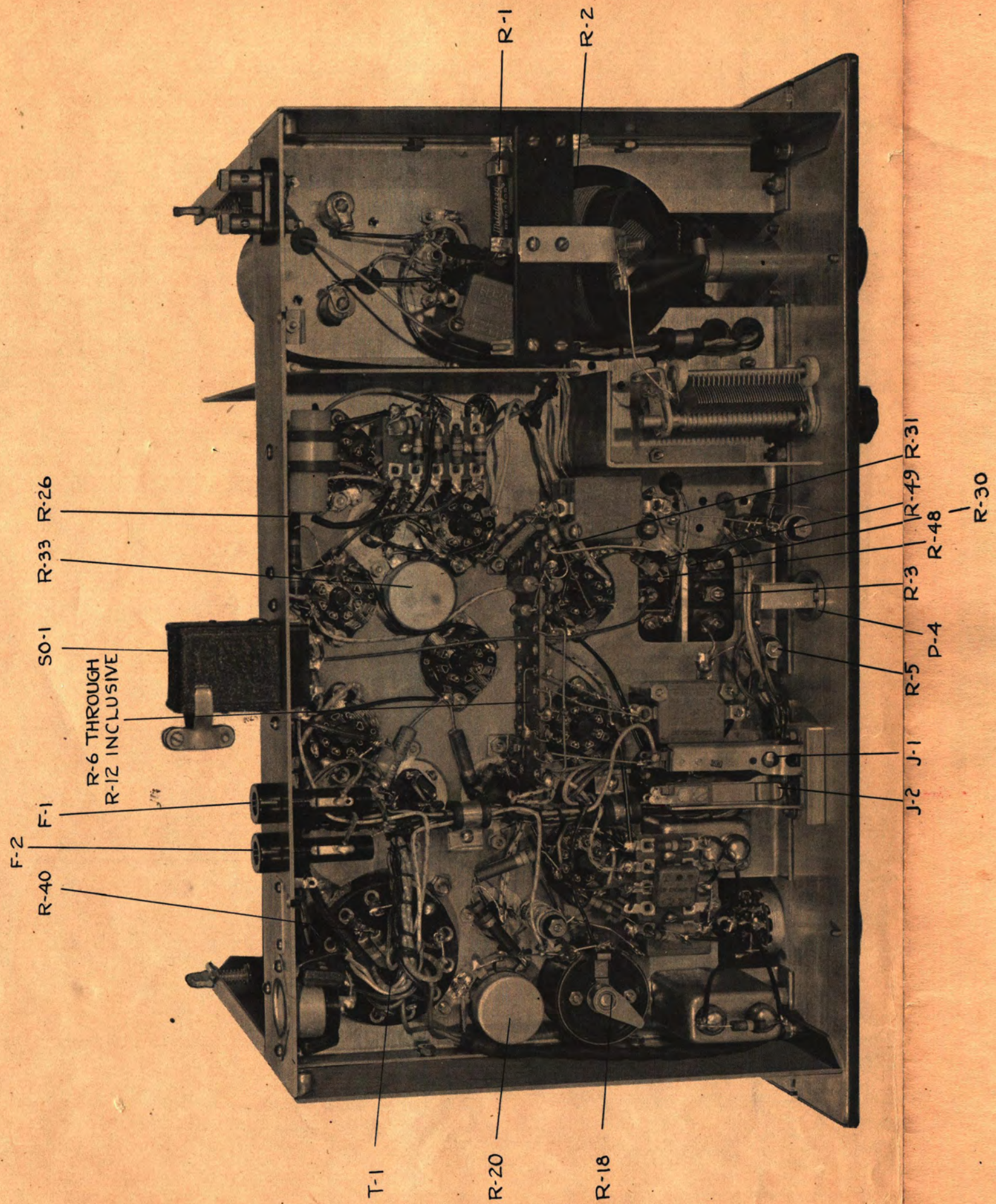

Figure 7. View of under side of chassis with main components identified.

PARTS LIST

Symbol Rating and Tolerance, Symbol Rating and Tolerance Symbol Rating and Tolerance

RESISTORS

R-1	10 kΩ	+10%
R-2	10 kΩ	+10%
R-3	50 kΩ	+10%
□ R-4	4.1 Ω	+10%
R-5	40 kΩ	+1%
R-6	1 MΩ	+10%
R-7	2700 Ω	+10%
R-8	0.1 MΩ	+10%
R-9	1 MΩ	+10%
R-10	3.3 kΩ	+10%
R-11	0.1 MΩ	+10%
R-12	0.1 MΩ	+5%
R-13	0.22 MΩ	+10%
R-14	0.1 MΩ	+5%
R-15	25 kΩ	+1%
R-16	3 MΩ	+5%
R-17	12.0 MΩ	+10%
R-18	20 kΩ	
R-19	25 kΩ	+1%
R-20	5 kΩ	+10%
R-21	0.5 MΩ	+1%
R-22	0.5 MΩ	+1%
R-23	150 kΩ	+5%
R-24	1 MΩ	+10%
□ R-25	25.5 kΩ	+5%
R-26	470 Ω	+10%
R-27	1 MΩ	+10%
R-28	120 kΩ	+5%
R-29	1000 Ω	+5%
R-30	5.6 MΩ	+10%
R-31	5.6 MΩ	+10%
R-33	30 kΩ	+10%
R-34	.330 MΩ	+10%
R-35	1 MΩ	+10%
R-36	1 MΩ	+10%
R-37	.270 MΩ	+10%
R-38	.220 MΩ	+10%
R-39	1.8 MΩ	+10%
□ R-40	500 Ω	+10%
R-41	450 Ω	+10%
R-42	450 Ω	+10%
R-43	450 Ω	+10%
R-44	82 kΩ	+10%
R-45	470 Ω	+10%
R-46	680 Ω	+5%
R-47	1800 Ω	+10%
R-48	100 kΩ	+10%
R-49	10 kΩ	+10%
R-50	820 Ω	+10%
R-51	160 Ω	+5%
R-52	470 Ω	+10%
R-53	1000 Ω	+10%
R-54	1000 Ω	+10%
R-55	390 Ω	+10%
R-56	4.1 Ω	+10%
R-58	100 kΩ	+1%
R-60	150 kΩ	+10%
R-61	15 Ω	+10%

□ Made up of two resistors in parallel

CONDENSERS

C-1	13.5 - 320 μmf	
C-2	0.00005 μf	+10%
C-3	0.02 μf	+10%
C-4	0.000035 μf	+10%
C-5	0.025 μf	+10%
C-6	0.025 μf	+10%
C-7	0.1 μf	+10%
C-8	0.1 μf	+10%
C-9	1.0 μf	+10%
C-10	0.025 μf	+10%
C-11	0.003 μf	+5%
C-12	30 μf	
C-13	20 μmf	+10%
C-15	0.02 μf	+10%
C-17	0.02 μf	+10%
C-19	10 μf	+50%, -10%
C-20	5 μf	+70%, -10%
C-21	10 μf	+50%, -10%
C-22	0.001 μf	+10%
C-23	20 μf	+50%, -10%
C-24	20 μf	+50%, -10%
C-25	40 μf	+50%, -10%
C-26	20 μf	
C-27	0.01 μf	+10%
C-28	0.01 μf	+10%
C-29	5 - 20 μmf	
C-30	200 μf	+50%, -10%
C-31	0.00005 μf	+10%
C-32	40 μf	
C-33	20 μf	
C-34	20 μf	
C-35	20 μf	
C-36	50 μmf	+10%

INDUCTORS

L-1	25 mh
L-2	25 mh
L-3	As specified for de-
L-4	
L-5	250 mh
L-6	1.9 mh

FUSES

For 115 v. operation:	
F-1	1.5 Amp.
F-2	1.5 Amp.
For 230 v. operation:	
F-1	1.0 Amp.
F-2	1.0 Amp.

SWITCHES

S-1	SWRW-12
S-2	SWT-333

TRANSFORMER

T-1 365-434

JACKS

J-1 CDSJ-818
J-2 CDSJ-818

METERS

M-1 MEDS-15-2 *80n 300 u Amp*
M-2 MEDS-14 *600 u Amp 700 n*

SOCKET

SO-1 1931-39

PLUGS

PL-1 CDPP-562
PL-2 CDMP-461-6

TUBES

V-1	RCA	6AL5
V-2	RCA	6SN7-GT
V-3	RCA	6SN7-GT
V-4	RCA	6SJ7
V-5	RCA	6SJ7
V-6	RCA	2050
V-7	RCA	6X5
V-8	RCA	OD3/VR150
V-9	RCA	OD3/VR150

PILOT LIGHTS

P-1	6.3 v.
P-2	6.3 v.
P-3	115 v.
P-4	6.3 v.

23-30

28-30

240
400
1000

