



# TRIODE

## DESCRIPTION

GL-833-A is a three-electrode transmitting tube of the high- $\mu$  type for use as a radio-frequency amplifier, oscillator, and Class B modulator. Because of its high perveance, the 833-A can be operated at high plate efficiency with low driving power.

Designed in a new way with post terminals which provide a sturdy structure and make bases unnecessary, the 833-A has a minimum amount of insulation within the tube. The anode is supported directly from its post terminal at the top of the

tube. Short, heavy-current leads are used to connect the anode and the grid to their respective terminals in order to carry the high circulating r-f current at the high frequencies and to minimize internal lead inductance.

As a result of its construction, the 833-A provides exceptional efficiency at high frequencies. It can be operated in Class C telegraph service with maximum input of 2000 watts at frequencies as high as 30 megacycles, and with reduced input at frequencies as high as 75 megacycles.

## TECHNICAL INFORMATION

*These data are for reference only. For design information refer to specifications.*

### GENERAL CHARACTERISTICS

Number of electrodes.....3

#### Electrical

Cathode—Filamentary

Filament voltage.....10 volts

Filament current.....10 amperes



**GENERAL  ELECTRIC**

*Supersedes ETX-162 dated 5-46*

TECHNICAL INFORMATION (CONT'D)

Average characteristics

Amplification factor.....	35	
Direct interelectrode capacitances		
Grid-plate.....	6.3	micromicrofarads
Grid-filament.....	12.3	micromicrofarads
Plate-filament.....	8.5	micromicrofarads
Frequency for maximum ratings.....	30	megacycles

Mechanical

Type of cooling.....	convection or forced air
Maximum ambient temperature, convection-cooled.....	60 centigrade
Net weight, approximate.....	1 pound
Shipping weight, approximate.....	3 pounds
Operating position.....	vertical with filament terminals up or down or horizontal with plate in a plane vertical

MAXIMUM RATINGS AND TYPICAL OPERATING CONDITIONS

CLASS B AUDIO-FREQUENCY POWER AMPLIFIER (TWO TUBES)

	Typical Operation			Maximum Ratings			
	CCS	ICAS	ICAS	CCS	ICAS	ICAS	
D-c plate voltage.....	3000	4000	4000	3000	4000	4000	volts
Maximum signal plate current, per tube†.....				500	500	500	milliamperes
D-c maximum signal plate input, per tube†.....				1125	1600	1800	watts
Plate dissipation†.....				300	400	450	watts
D-c grid voltage‡.....	-70	-100	-100				volts
Peak a-f grid input voltage.....	400	480	510				volts
Zero signal plate current.....	100	100	100				milliamperes
Maximum signal plate current.....	750	800	900				milliamperes
Maximum signal driving power, approximate.....	20	29	38				watts
Effective load, plate to plate.....	9500	12000	11000				ohms
Maximum signal plate power output, approximate.....	1650	2400	2700				watts

CLASS B RADIO-FREQUENCY POWER AMPLIFIER

Carrier conditions per tube for use with a max modulation factor of 1.0

	CCS	ICAS	ICAS	CCS	ICAS	ICAS	
D-c plate voltage.....	3000	4000	4000	3000	4000	4000	volts
D-c grid voltage‡.....	-70	-120	-120				volts
D-c plate current.....	150	150	150	300	300	300	milliamperes
Plate input.....				450	600	675	watts
Plate dissipation.....				300	400	450	watts
Peak r-f grid input voltage.....	90	120	130				volts
Driving power§ Δ, approximate.....	10	14	21				watts
Plate power output, approximate.....	150	225	250				watts
D-c grid current, approximate Δ.....	2	2	3				milliamperes

CLASS C RADIO-FREQUENCY POWER AMPLIFIER AND OSCILLATOR—PLATE-MODULATED

Carrier conditions per tube for use with a max modulation factor of 1.0

	CCS	ICAS	ICAS	CCS	ICAS	ICAS	
D-c plate voltage.....	2500	3000	4000	2500	3000	4000	volts
D-c grid voltageπ.....	-300	-300	-325	-500	-500	-500	volts
	4000	3600	3600				ohms
D-c plate current.....	335	415	450	400	450	450	milliamperes
D-c grid current, approximate.....	75 Δ	85 Δ	90 Δ	100	100	100	milliamperes
Plate input.....				835	1250	1800	watts
Plate dissipation.....				200	270	350	watts
Driving power Δ, approximate.....	30	37	42				watts
Plate power output, approximate.....	635	1000	1500				watts
Peak r-f grid voltage.....	460	490	520				volts

MAXIMUM RATINGS AND TYPICAL OPERATING CONDITIONS (CONT'D)

CLASS C RADIO-FREQUENCY POWER AMPLIFIER AND OSCILLATOR

Key-down conditions per tube without modulation □

	Typical Operation			Maximum Ratings			
	CCS	ICAS	ICAS	CCS	ICAS	ICAS	
	*	*	*	*	*	*	
D-c plate voltage.....	3000	4000	4000	3000	4000	4000	volts
D-c grid voltage#.....	-200	-200	-225	-500	-500	-500	volts
	3500	2650	2400				ohms
	425	380	380				ohms
D-c plate current.....	415	450	500	500	500	500	milliamperes
D-c grid current, approximate.....	55 Δ	75 Δ	95 Δ	100	100	100	milliamperes
Plate input.....				1250	1800	2000	watts
Plate dissipation.....				300	400	450	watts
Peak r-f grid input voltage, approximate..	360	375	415				volts
Driving power Δ, approximate.....	20	26	35				watts
Plate power output, approximate.....	1000	1440	1600				watts

\* Forced-air cooling required at these conditions of operation. When forced-air cooling is required an air flow of 40 cfm from a two-inch diameter nozzle directed vertically downward on bulb between grid and plate seals is required. Bulb temperature between grid and plate seals must not exceed 145 C. For conditions of operation where forced-air cooling is not required, adequate free circulation of air around the tube is necessary for satisfactory operation.

† Averaged over any audio-frequency cycle of sine-wave form.

‡ For a-c filament supply.

§ At crest of audio-frequency cycle.

Δ Subject to wide variations depending on the impedance of the load circuit. High-impedance load circuits require more grid current and driving power to obtain the desired output. Low-impedance circuits need less grid current and driving power, but plate circuit efficiency is sacrificed. The driving stage should be capable of delivering considerably more than the required driving power.

π Obtained by grid resistor of value shown or by partial self-bias methods.

□ Modulation, essentially negative, may be used if the positive peak of the audio-frequency envelope does not exceed 115 per cent of the carrier conditions.

#Obtained from fixed supply, by grid resistor (3500, 2650, 2400), or by cathode resistor (425, 380, 380).

APPLICATION NOTES

The GL-833-A can be operated at frequencies as high as 30 megacycles. The tube may be operated at higher frequencies provided the maximum values of plate voltage and power input are reduced as the frequency is raised (other maximum ratings are the same as shown above).

The tabulation below shows the highest percentage of maximum plate voltage and power input that can be used up to 75 megacycles for the various classes of service. Special attention should be given to adequate ventilation of the bulb at these frequencies.

Frequency.....	Natural Cooling			Forced-air Cooling			megacycles
	30	50	75	20	50	75	
Maximum permissible percentage of maximum rated plate voltage and plate input							
Class B, r-f.....	100	98	94	100	97	93	per cent
Class C, plate-modulated.....	100	90	72	100	83	65	per cent
Class C, unmodulated.....	100	90	72	100	83	65	per cent

GL-833-A TYPICAL CHARACTERISTICS ( $E_f = 10$  VOLTS A-C)

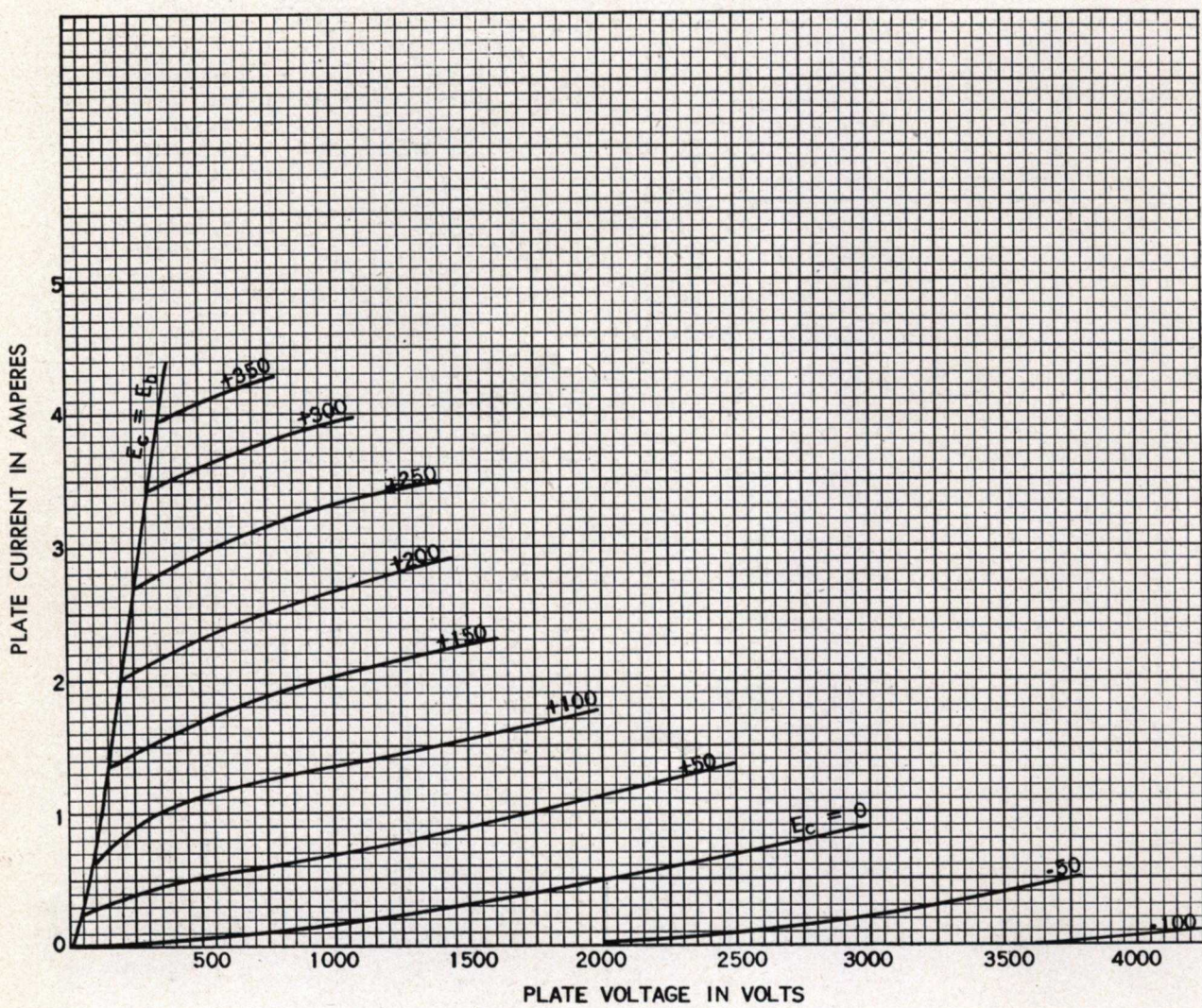

K-69087-72A109

2-6-47

GL-833-A  
TYPICAL CHARACTERISTICS  
 $E_i = 10$  VOLTS A-C

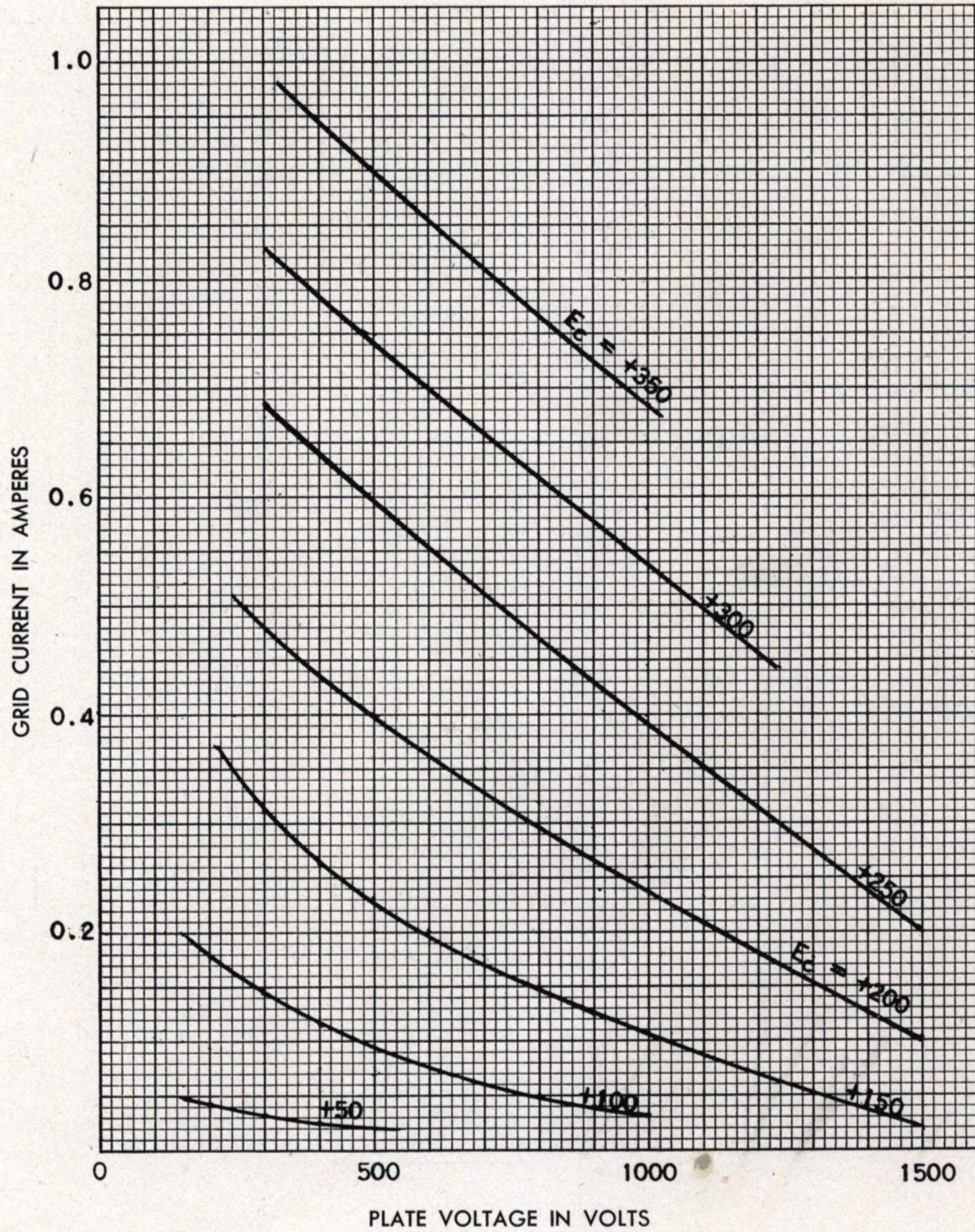

K-69087-72A107

2-6-47

# GL-833-A

ETX-162A

PAGE 6

5-47

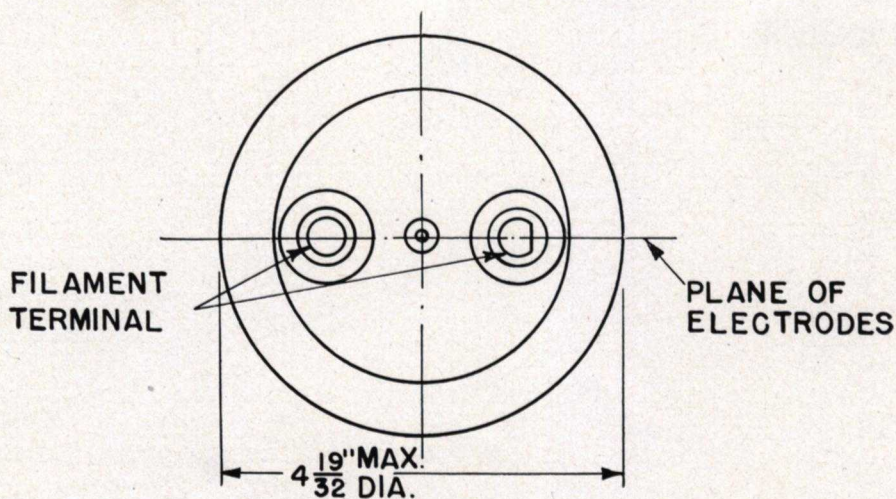
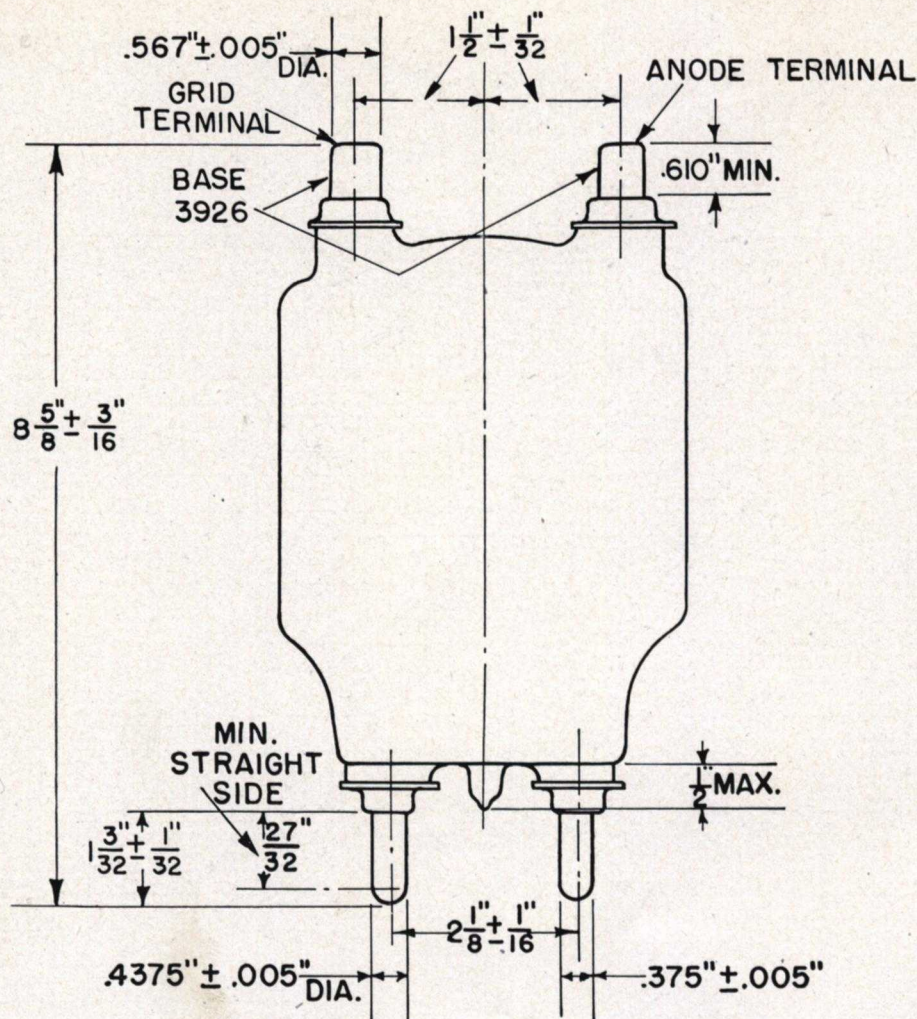

GL-833-A OUTLINE

NOTE: THE HORIZONTAL ANGLE BETWEEN THE PLANE DETERMINED BY THE AXIS OF THE FILAMENT TERMINALS AND THE PLANE DETERMINED BY THE AXIS OF THE GRID AND ANODE CAPS IS NOT MORE THAN 5 DEGREES.

K-6966950

9-23-44

Electronics Department

**GENERAL ELECTRIC**

Schenectady, N. Y.