

INSTRUCTIONS

A-C MAGNETIC SWITCH

CR2811-C24B ALSO FORM . . . SWITCH

The various forms of this switch consist of a two-pole (or more), 150-ampere contactor with accessories suitable for push-button control. The maximum ampere ratings for these switches are 150 amperes for open switch and 135 amperes for enclosed switch. Fig. 4 is a typical example.

INSTALLATION

1. Remove the bindings from the arc chutes and armature.
2. Thoroughly remove the rust-inhibiting material which covers the magnet sealing surfaces.
3. Before applying power to the contactor, operate the moving parts by hand to make sure they operate freely.

MAINTENANCE

The sealing surfaces on the magnet frame and armature should be kept clean.

Do not lubricate tips. In general, tips will not require attention during their normal life, but if prominent beads form on the surface, the contact faces should be dressed with a fine file. To determine the condition of the contacts, block the contactor closed, applying force to the magnet laminations and not the supporting bracket and measure the gap between the movable tip and tip support at point (A), Fig. 4. When this gap is $\frac{1}{16}$ inch or less, the tips should be renewed.

To Renew Stationary Tips

Remove the arc chutes by sliding them upward off the projection of the stationary tip arcing horn. Remove screws (B) and the movable tip arc horns. Next loosen screw (C) sufficiently to allow armature to open beyond the armature stop. The slotted stationary tips may now be removed by loosening screws (D) and drawing them forward. It is not necessary to remove screws (D) completely.

To Renew Movable Tips

Insert a screw driver in the top of the spring at point (G) and slide the spring upward out of its holder. The screw holding the tip to the shunt is then exposed for removal. To replace the spring, slide the movable tip forward and place the end of the spring over the screw. When slide both spring and tip backward into place. After reassembling the arcing horns, the

gap between the end of the horn and the stationary tip should be $\frac{1}{2}$ inch plus or minus $\frac{1}{32}$.

To Renew Interlock Tips

The entire interlock should be removed from the contactor base by removing screw (E) for replacement of the interlock tips. Removing screws (F) permits complete disassembly of the interlock unit.

To Reassemble Normally Open Interlock

Assemble the parts on the operating rod as shown in Fig. 1. Place the entire assembly on the molded base with the longer portion of the operating rod toward the contactor and replace screws (F). Check to see that the operating rod moves without binding.

To Reassemble Normally Closed Interlock

Assemble the parts on the operating rod as shown in Fig. 2. Complete reassembly in the manner described for the normally open interlock.

To Renew Coil

Remove the arc chutes as described previously. Loosen screws (B) sufficiently to allow arc horns to be turned down over load connections. Next remove screw (C) and armature stop (R). This permits the armature to be opened to its maximum amount. The coil can now be removed by drawing it outward and turning it clockwise through the opening between the magnet and the coil support strap.

RENEWAL PARTS

When ordering renewal parts, refer to the nearest Sales Office of the General Electric Company, giving the complete nameplate rating, the Cat. No., a description of the part wanted, and the quantity desired.

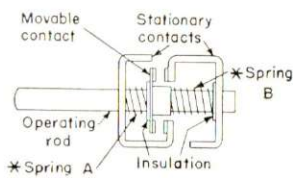

Fig. 1

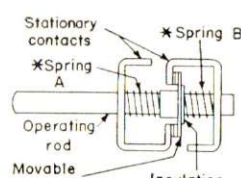
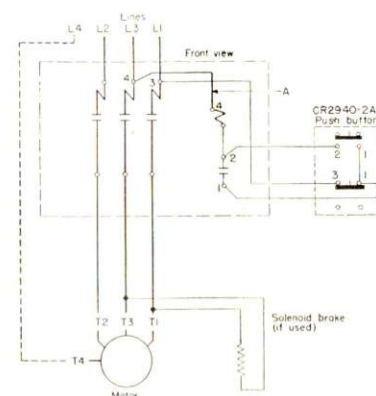

Fig. 2

* Spring A has a free length of approx 0.64 in.
* Spring B has a free length of approx 1.69 in.
(The length of the spring when in neither tension nor compression is its free length)



For Separate Control: Remove wire A and connect control source to No. 4 on coil and No. 3 on push button.
For 2-phase 4-wire Operation: Where not prohibited by local codes, L4 may be connected to T4 as shown by dotted line on diagram. L1-L3 is phase No. 1, L2-L4 is phase No. 2.
For 2-phase 3-wire Operation: L3 and T3 are common line circuit.

Fig. 3. Typical wiring diagram

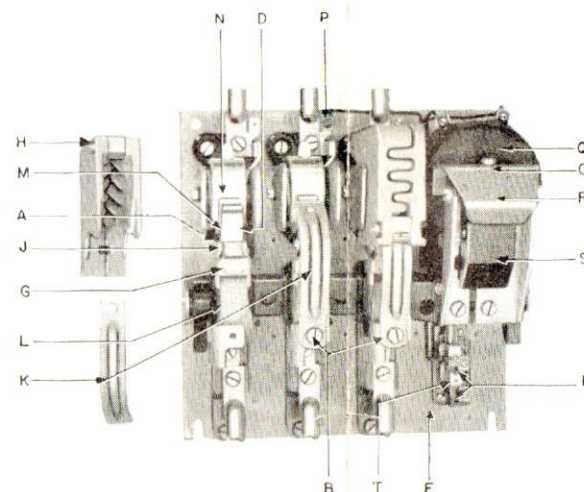

Fig. 4. Typical magnetic switch with arc chute and arcing horn removed from third pole

PRINCIPAL AND RENEWAL PARTS

Ref Letter	Description	Cat. No.
H	Arc chute	6960039G1
J	Contact spring	2416432
K	Arc horn	8280986P1
L	Shunt assembly	6963440G3
M	Movable contact	6908543
N	Stationary contact	5352149
P	Control terminal	
Q	Coil	Order by No. marked on coil
R	Armature stop	
S	Armature	
T	Electrical interlock assembly	