

INSTRUCTIONS

A-C AND D-C AUXILIARY RELAYS

TYPES

HGA14A TO 14K INCLUSIVE, HGA14N, HGA14V

A-C CURRENT RELAYS

TYPES

HGC11A, HGC11B AND HGC11C

Switchgear

GENERAL  ELECTRIC
SCHENECTADY, N.Y.

RECEIVED
MAY 15 1900

Handwritten signature

THE STEAM POWERED RADIO COMPANY

NEW YORK

100 NASSAU ST. N.Y.C.

ORDERED BY THE STEAM POWERED RADIO COMPANY

NEW YORK

100 NASSAU ST. N.Y.C.

STEAM POWERED RADIO COMPANY

A-C AND D-C AUXILIARY RELAYS AND A-C CURRENT RELAYS

These instructions do not purport to cover all details or variations in equipment nor to provide for every possible contingency to be met in connection with installation, operation or maintenance. Should further information be desired or should particular problems arise which are not covered sufficiently for the purchaser's purposes, the matter should be referred to the General Electric Company.

GENERAL INFORMATION

Application

The HGA and HGC relays described below are double-pole, hinge-type relays suitable for application wherever a high-speed, low-energy device is required. Details of construction of the individual relays, which may adapt them to specific duties, are brought out in the following paragraphs on construction and operation.

Construction and Operation

The relay units covered by this instruction book are all of the same basic construction. The contact circuits are closed or opened by moving contact arms, controlled by a hinge-type armature, which in turn is actuated by the operating coil and restrained by an adjustable control spring. The length of contact gap is adjustable by means of screw contacts and locknuts in the front fixed-contact positions. The armature gap and back-contact wipe can be controlled by the screws and locknuts located on the moving contact arms. These latter features make it possible to reduce the pickup energy and pickup time to relatively low values.

The armature, magnet assembly and contact assemblies are all mounted on a compact molded textolite base provided with a mounting strap. The relays have either a molded textolite cover or are mounted in a standard six-inch case. In either case, studs are provided for back-of-panel connections. Individual models are described in greater detail in the following sections.

HGA14A

This model is described fully by the general discussion above.

HGA14B

The HGA14B is identical in construction with the HGA14A except that its operating coil is intermittently rated to obtain high-speed pickup, and stronger contact springs have been used to eliminate contact chatter under this condition.

HGA14D

The HGA14D relay unit is similar in construction to the HGA14A except that it is available for D-c applications only. It is supplied with external capacitor and adjustable resistor to provide an adjustable time delay in pickup.

HGA14E

The HGA14E model consists of two HGA14B units mounted in a six-inch case.

HGA14H

The HGA14H consists of two HGA14A units in a six-inch universal case, or a single-unit, double-end drawout case.

HGA14J

The HGA14J is similar to the HGA14A except for stronger contact springs and special test adjustments to secure pickup time settings as specified by the customer.

HGA14K

The HGA14K is similar in construction to the HGA14A except for contact springs and method of adjustment in test. It is recommended for use in locations, such as on circuit breaker mechanisms, where the relay is subjected to mechanical shock during operation.

HGA14N

The HGA14N is similar to the HGA14A except that the operating coils have been designed to offer very low burdens at rated voltage. It is designed for use as an auxiliary relay in conjunction with protective devices whose contacts are incapable of handling the current required by standard HGA auxiliary relays.

HGA14V

The HGA14V is similar to the HGA14A except that it is designed for dual frequency rating and pickup is adjusted for less than 90 per cent of the higher frequency rating and lower voltage rating.

HGC11A, 11B & 11C

The HGC relays included in this instruction book are similar in construction to the HGA14A except that they are designed for use as overcurrent and undercurrent devices with special adjustments of the ratio of pickup current to dropout current.

All special adjustments of HGA or HGC units are covered more completely under Inspection and Adjustment.

Ratings

The HGA14A, 14H, 14J, and 14N relays are available for both a-c and d-c in all standard voltage ratings and frequencies. The HGA14B, 14D, 14E, and 14K are available in all standard voltage ratings, but for d-c service only. The HGA14V is available for a-c only and is assigned a dual frequency rating. The HGC type relays are designed for a-c overcurrent and undercurrent relays in ratings up to 10 amps.

The contacts will make and carry 5 amps continuously or 30 amps for 1 minute, and will interrupt the following:

Volts	Interrupt (Single Break)
115 a-c	2 amps.
230 a-c	1 amp.
125 d-c	0.6 amp.
250 d-c	0.25 amp.

Rated D-C Volts	Coil Ohms	Resistor Ohms	Raged Max. Time Delay, Secs.	Capacitor Mu f
48	640	0-700	.067	100
125	12,800	0-4000	.100	25
125	3,070	0-4000	.050	25
250	12,800	0-12000	.100	25
250	12,800	0-12000	.150	50
125	12,800	0-4000	.200	50

The HGA14N has a burden of approximately 1.7 watts when cold and 1.5 watts when hot.

The burdens of the HGC relays at 5 amps. 60 cycles are as follows:

HGC11A:

Rating	Impedance	Volt Amps.	Watts
1.6 amps.	7.1 ohms	177 v-a	82
4	1.05	26.2	11.8
7	0.386	9.7	4.4
10	0.25	6.3	2.9

HGC11B:

Rating	Impedance	Volt-Amps.	Watts
2 amps	3.76 ohm	100 v-a	47

HGC11C:

3.3 amps	0.46 ohm	11.5 v-a	5.5
----------	----------	----------	-----

SHIPPING - UNPACKING - STORAGE

Immediately upon receipt of HGA or HGC relays, an examination should be made for any damage sustained during shipment. If injury or rough handling is evident, a damage claim should be filed at once with the transportation company and the nearest General Electric Sales Office notified promptly.

If it is necessary to store the relay for any length of time before installation, it should be placed in a dry location, free from excessive vibration, preferably resealed in its original packing carton.

The values given in the above table are for non-inductive loads with contacts set as recommended under Adjustments and Inspection.

Burdens

The burdens of HGA14A, 14J, 14K, 14V and for each unit of the HGA14H are as follows:

for a-c coils: 13 voltamperes, 5 watts (approx.)
d-c coils: 5 watts, cold; 4 watts hot (approx.)

Burdens of HGA14B and each unit of HGA14E are as follows:

for potential coils: 20 watts (approx.) *
current coils: 10 watts (approx.) *

* Intermittent rating

The characteristics of the HGA14D relay is given in the table below:

INSTALLATION

Location and Mounting

The relay should be installed in a location that is clean and dry, and free from excessive vibration. It should be mounted on a vertical surface by means of the steel mounting strap, or by means of the large steel mounting studs in the case of relays in universal cases. Care should be taken to allow sufficient clearance in front of the relay to remove the textolite cover. Outline and panel drilling dimensions are listed in the table in the section on connections.

Connections

Internal connections, as well as outline and panel drilling, of the relays covered by this instruction book are given at the back of the book and are listed in the following table:

Relay Type	Outline, Panel Drilling Internal Connections
HGA14A	Fig. 1
HGA14B	Fig. 2
HGA14D Relay	Fig. 2
HGA14D Auxiliaries	Fig. 3
HGA14D Ext. Conn.	Fig. 4
HGA14E & H (Univ. case)	Fig. 5
HGA14H (Drawout case)	Figs. 7 & 8
HGA14J	Fig. 1
HGA14K	Fig. 1
HGA14N	Fig. 1
HGA14V	Fig. 9
HGC11A	Fig. 1
HGC11B	Fig. 2
HGC11C	Fig. 2

In the case of the HGA14D reference should also be made to the auxiliary outline and the external connections.

ADJUSTMENTS AND INSPECTION

Pick-Up

All HGA relays covered by these instructions, except HGA14D, 14K, and 14N have been adjusted at the factory to pickup at 30 per cent of rating (D-C), or 40 per cent of rating (A-C). The pickup of the HGA14D is dependent upon the desired time delay setting but is usually below 50 per cent of rating. The HGA14K, since it has a strong control spring setting to reduce closing tendency under shock, is set to pick up at approximately 80 per cent of rating. The HGA14N, because of its low-burden design, will pick up at approximately 80 per cent of rating.

The pickup value is adjusted by means of the control spring at the lower tail-end of the armature. It should be in the upper hole of the spring post for relays adjusted for 30-40 per cent pickup and in the lower hole for relays adjusted for 60-80 per cent pickup. An exception to this is the HGA14N which must have a weak spring setting because of its low-burden coil. A finer adjustment of pickup is obtained by means of the notches in the armature tail. The pickup - dropout ratio adjustments of the HGC relays are controlled by the setting of "a" contact wipe and control spring tension.

The HGA14D requires special adjustments in that the control spring is set in the weakest position possible; that is, its bottom loop is hooked in the top hole of the spring post and its top loop is in the top usable notch of the armature tail. Adjustment of time delay pickup is made by means of the series resistor; increasing resistance increases the time while decreasing it has the opposite effect.

The HGC relays as previously mentioned, have special adjustments of pickup and dropout. The HGC11A is set for 35 per cent pickup and drops out at 60 per cent of pickup. The HGC11B is set for 70 per cent pickup only. The HGC11C is set for 90 per cent pickup and drops out at 85 per cent of pickup.

The pickup adjustments in general are similar for all the relays. As shipped from the factory all relays having low pickup are provided with but one "b", or normally closed, contact circuit. The left-hand (front view) screw contact is backed out of engagement with its moving contact. This is necessary since the low control spring tension used on

relays adjusted for 30 per cent pickup is not great enough to give sufficient pressure on two "b" contacts. Both "b" contacts can be utilized if the control spring tension is increased sufficiently to raise the pickup to 60 per cent of rating (D-c) or 80 per cent of rating (A-c). In the case of the HGA14B and 14D, and HGC11B and 11C, the left "b" contact has been replaced by a backstop, and in the HGA14K and 14N the pickup is set at the factory for 80 per cent of rating, so no further adjustment is possible.

Contact Wipe

The minimum recommended contact wipe is one turn of the screw in the moving contact arm. To set the wipe close the armature by hand and adjust the screws so that they are just touching the contact carrier. Then back them each off one full turn and lock them in place with the lock nut. The minimum recommended contact gap is 3-3/4 turns of the fixed-contact screw. To adjust, turn both screws in until there is zero gap on the "a", or normally open contacts. Then back each screw out 3-3/4 turns and lock in position with the locknut. Lower contact gaps are permissible in special applications provided contact interrupting capacities are pro-rated according to the table under contact ratings. These ratings are for minimum recommended gap setting.

MAINTENANCE

Auxiliary relay equipment should be checked for operation at regular intervals, preferably at the same time that the associated protective devices are inspected. Relays should be checked for pickup values, and dropout values and time settings when specified. These settings should not require readjustment, but if changes are necessary the points discussed under adjustment and inspection should be observed.

If it is found necessary to clean the contact buttons, do so with a clean, fine file. Never use emery or crocus cloth for this purpose as insulating particles may become embedded in the contact surface.

RENEWAL PARTS

When ordering renewal parts address the nearest Sales Office of the General Electric Company specify the quantity required, name of the part wanted and the complete nameplate data. If possible, give the General Electric Company's requisition number on which the relays were furnished.

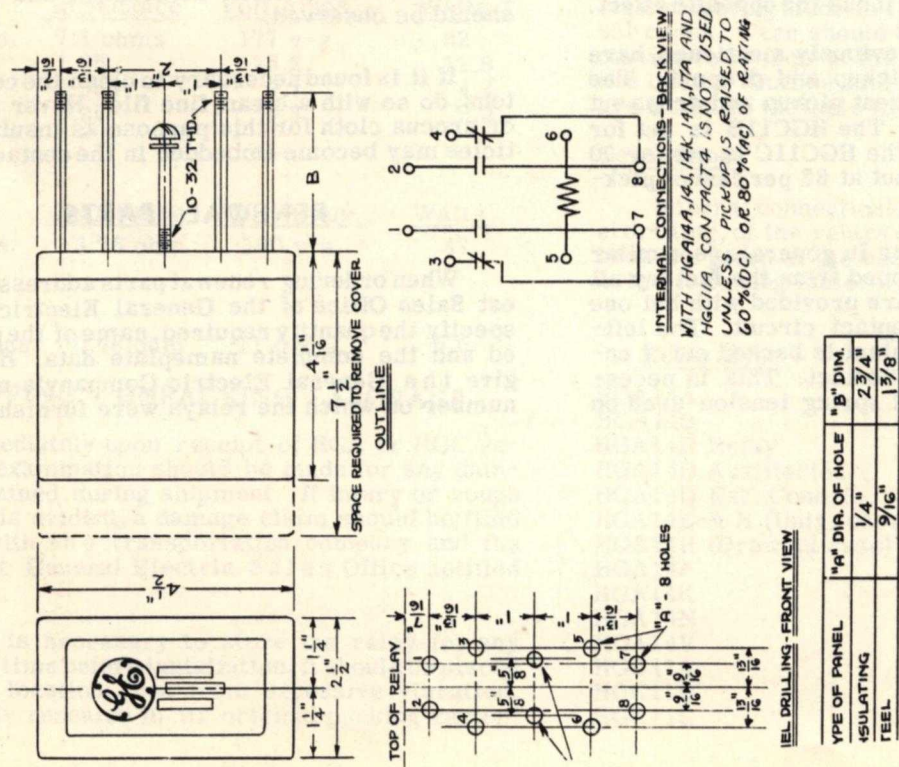

FIG. 1

OUTLINE, PANEL DRILLING AND INTERNAL CONNECTIONS OF HGA14A, HGA14J, HGA14K, HGA14N AND HGC11A.

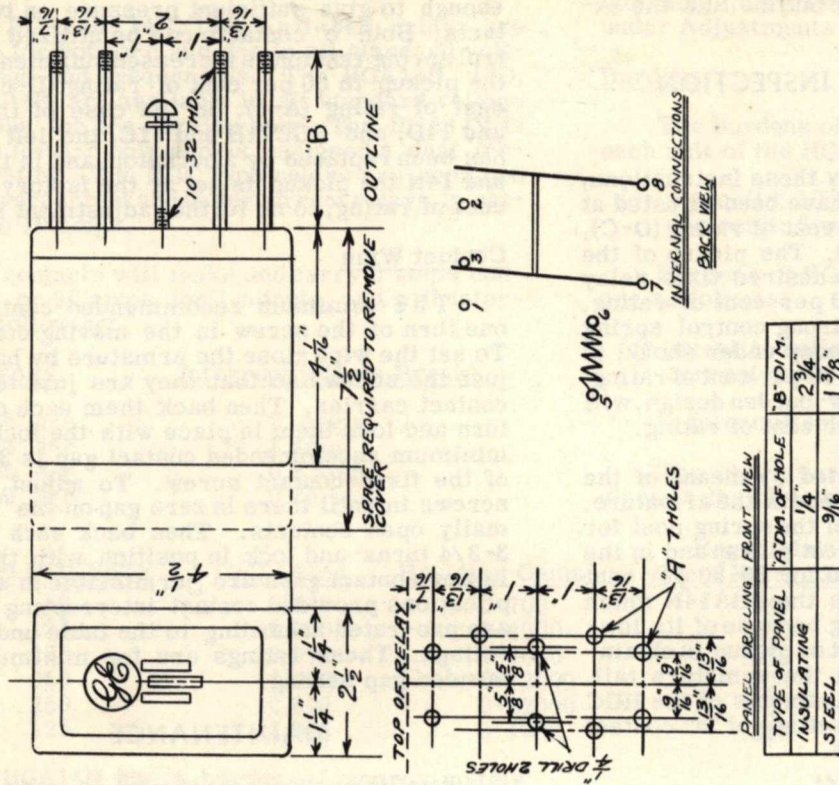
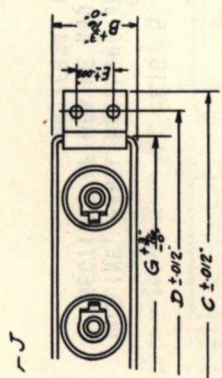

FIG. 2

OUTLINE, PANEL DRILLING AND INTERNAL CONNECTIONS OF HGA14B, HGA14D, HGC11B, AND HGC11C.



CAPACITOR DIMENSIONS		CART. MFD		A		B		C		D		E		F		G		H	
67X18	50	5.8"	4.9"	5.8"	4.9"	5.8"	4.9"	5.8"	4.9"	5.8"	4.9"	5.8"	4.9"	5.8"	4.9"	5.8"	4.9"	5.8"	4.9"
67X16	25	4.8"	3.9"	4.8"	3.9"	4.8"	3.9"	4.8"	3.9"	4.8"	3.9"	4.8"	3.9"	4.8"	3.9"	4.8"	3.9"	4.8"	3.9"

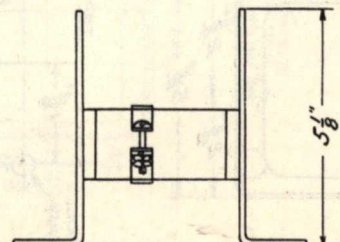
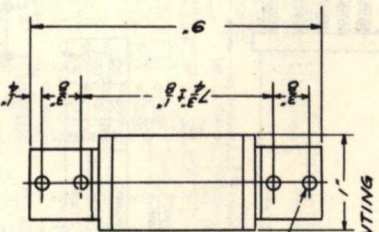
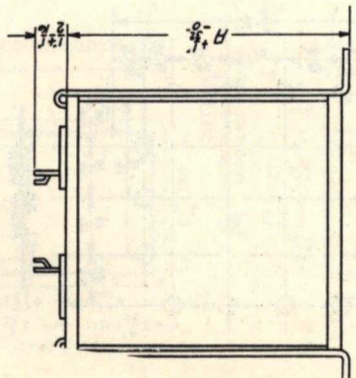

FIG. 3 MOUNTING DIMENSIONS OF CAPACITOR AND RESISTOR USED WITH HGAI4D RELAYS.

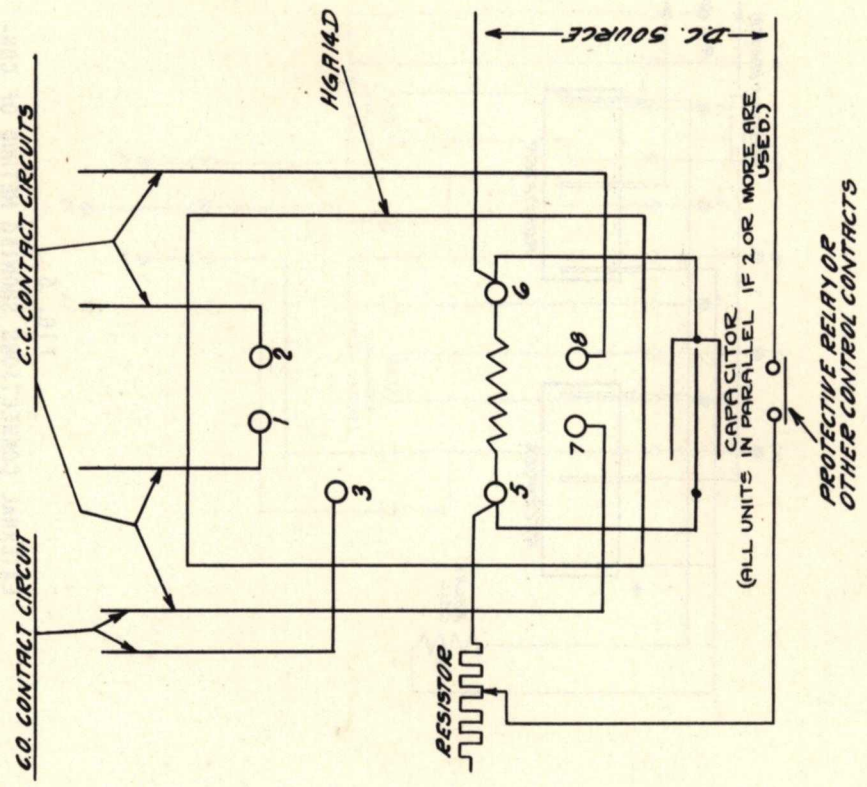

FIG. 4 EXTERNAL CONNECTIONS (BACK VIEW) OF HGAI4D (TIME-DELAY PICKUP).

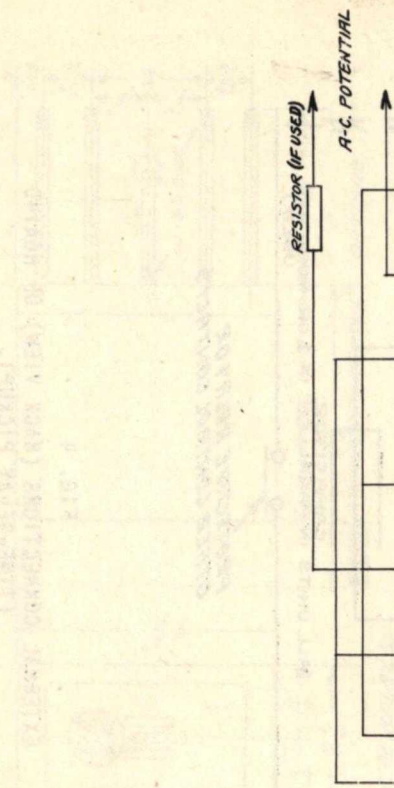

FIG. 6
EXTERNAL CONNECTIONS SHOWING METHOD OF CONNECTING FULL-WAVE RECTIFIER AND RELAY OPERATING COIL.

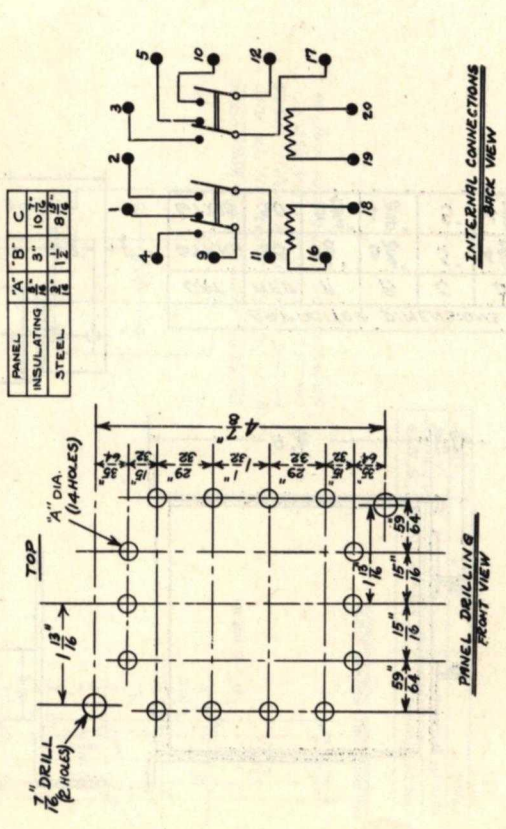
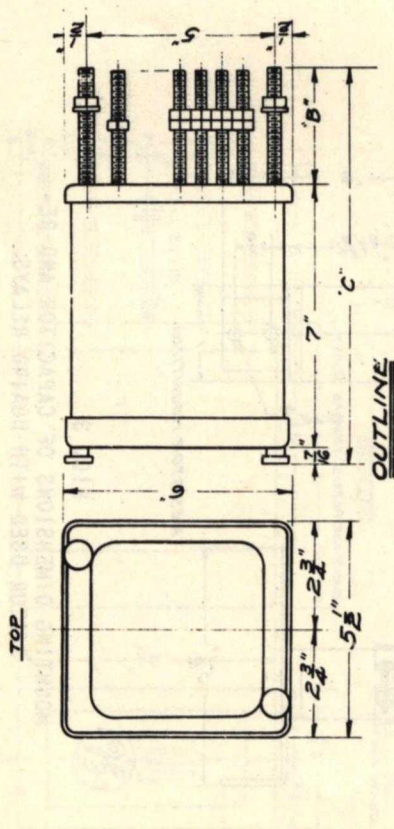

FIG. 5
OUTLINE, PANEL DRILLING AND INTERNAL CONNECTIONS OF HGAI4E AND HGAI4H RELAYS IN UNIVERSAL CASE.

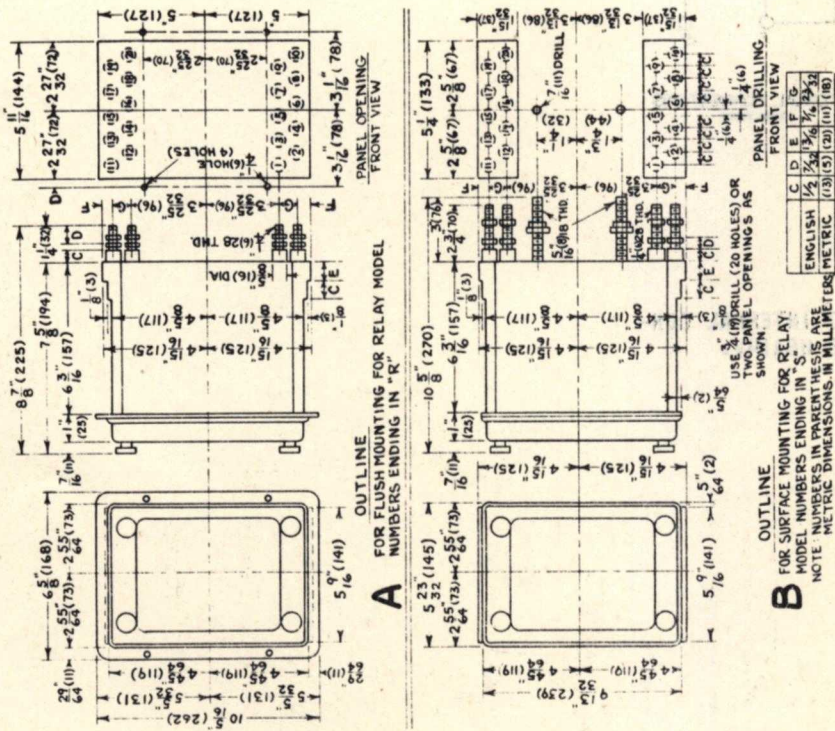

FIG. 7
OUTLINE AND PANEL DRILLING FOR HGA14H IN DRAWOUT CASE.

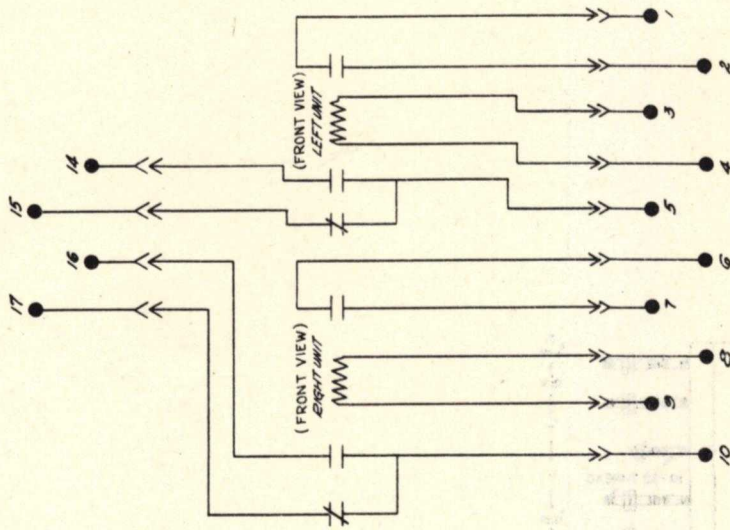

FIG. 8
INTERNAL CONNECTIONS FOR HGA14H IN DRAWOUT CASE.

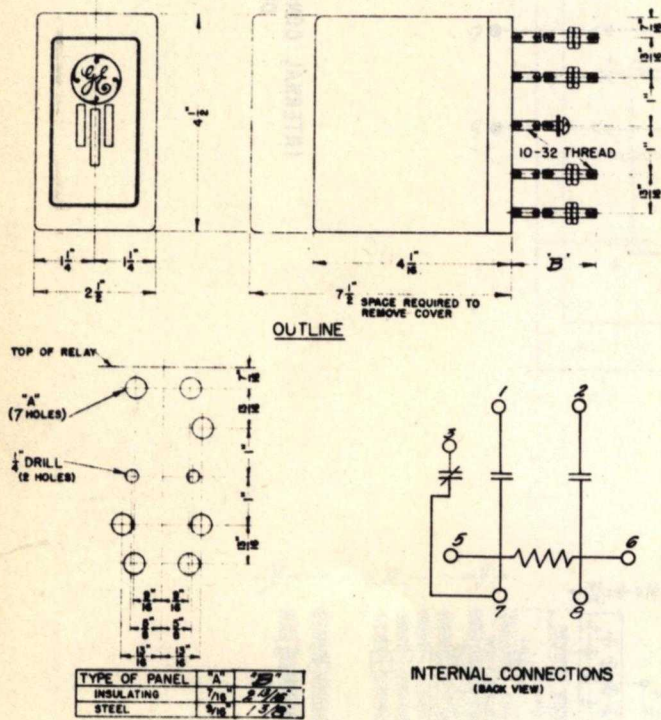

FIG. 9
 OUTLINE, PANEL DRILLING, AND INTERNAL CON-
 NECTIONS FOR RELAY TYPE HGAI4V.

IF YOU REQUIRE SERVICE

IF AT ANY TIME you find it necessary to repair, recondition, or rebuild your G-E apparatus, there are 26 G-E service shops whose facilities are available day and night for work in the shops or on your premises. Factory methods and genuine G-E renewal parts are used to maintain the original performance of your G-E apparatus. If you need parts only, immediate shipment of many items can be made from warehouse stock.

The services of our factories, engineering divisions, and sales offices are also available to assist you with engineering problems. For full information about these services, contact the nearest service shop or sales office listed below:

APPARATUS SERVICE SHOPS

- Atlanta, Ga.....496 Glenn St., S.W.
 - *Baltimore 30, Md.....920 E. Fort Ave.
 - Buffalo 11, N. Y.....318 Urban St.
 - Charleston 28, W. Va...306 MacCorkle Ave., S.E.
 - Chicago 80, Ill.....849 S. Clinton St.
 - Cincinnati 2, Ohio.....215 W. Third St.
 - Cleveland 4, Ohio.....4966 Woodland Ave.
 - Dallas 2, Texas.....1801 N. Lamar St.
 - Denver 5, Colo.....3353 Larimer St.
 - Detroit 2, Mich.....5950 Third Ave.
 - Houston 1, Texas.....1312 Live Oak St.
 - Johnstown, Pa.....841 Oak St.
 - Kansas City 8, Mo.....819 E. 19th St.
 - Los Angeles 1, Calif.....6900 Stanford Ave.
 - Milwaukee 3, Wisc.....940 W. St. Paul Ave.
 - Minneapolis 1, Minn.....410 Third Ave., N.
 - New York 14, N. Y.....416 W. 13th St.
 - Philadelphia 23, Pa.....429 N. Seventh St.
 - Pittsburgh 6, Pa.....6519 Penn Ave.
 - St. Louis 1, Mo.....1110 Delmar Blvd.
 - Salt Lake City 9, Utah...141 S. Third West St.
 - San Diego 1, Calif.....2045 Kettner Blvd.
 - San Francisco 3, Calif.....1098 Harrison St.
 - Seattle 4, Wash.....1508 4th Ave., S.
 - West Lynn 3, Mass.....920 Western Ave.
 - Youngstown 3, Ohio.....121 E. Boardman St.
- * Convenient G-E Renewal Parts Center for over-the-counter purchases of industrial parts, located at same address.

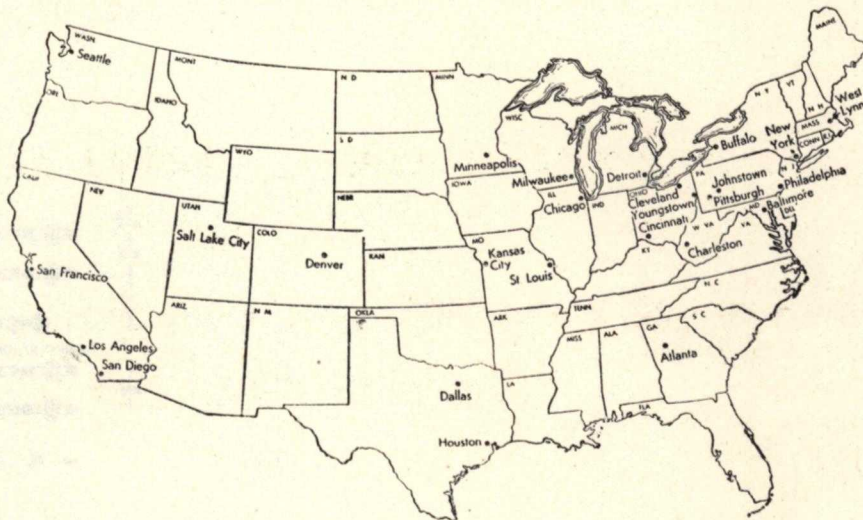

APPARATUS SALES OFFICES

- | | | |
|---------------------------------------------------------------------------------------------------------------------------------------------------------------------------------------------------------------------------------------------------------------------------------------------------------------------------------------------------------------------------------------------------------------------------------------------------------------------------------------------------------------------------------------------------------------------------------------------------------------------------------------------------------------------------------------------------------------------------------------------------------------------------------------------------------------------------------------------------------------------------------------------------------------------------------------------------------------------------------------------------------------------------------------------------------------------------------------------------------------------------------------------------------------------------------------------------------------------------------------------------------------------------------------------------------------------------------------------------------------------------------------------------------------------------------------------------------------------------------------------------------------------------------------------------------------------------------------------------------------------------------------------------------------------------------------------------------------------------------------------------------------------------------------------------------------------------------------------------------------------------------------------------------------------------------------------------------------------------------------------------------------------------------------------------------------------|-----------------------------------------------------------------------------------------------------------------------------------------------------------------------------------------------------------------------------------------------------------------------------------------------------------------------------------------------------------------------------------------------------------------------------------------------------------------------------------------------------------------------------------------------------------------------------------------------------------------------------------------------------------------------------------------------------------------------------------------------------------------------------------------------------------------------------------------------------------------------------------------------------------------------------------------------------------------------------------------------------------------------------------------------------------------------------------------------------------------------------------------------------------------------------------------------------------------------------------------------------------------------------------------------------------------------------------------------------------------------------------------------------------------------------------------------------------------------------------------------------------------------------------------------------------------------------------------------------------------------------------------------------------------------------------------------------------------------------------------------------------------------------------------------------------------------------------------------------------------------------------------------------------------------------------------------------------------------------------------------------------------------------------------------------------------------------------------------------------------------------------|------------------------------------------------------------------------------------------------------------------------------------------------------------------------------------------------------------------------------------------------------------------------------------------------------------------------------------------------------------------------------------------------------------------------------------------------------------------------------------------------------------------------------------------------------------------------------------------------------------------------------------------------------------------------------------------------------------------------------------------------------------------------------------------------------------------------------------------------------------------------------------------------------------------------------------------------------------------------------------------------------------------------------------------------------------------------------------------------------------------------------------------------------------------------------------------------------------------------------------------------------------------------------------------------------------------------------------------------------------------------------------------------------------------------------------------------------------------------------------------------------------------------------------------------------------------------------------------------------------------------------------------------------------------------------------------------------------------------------------------------------------------------------------------------------------------------------------------------------------------------------------------------------------------------------------------------------------------------------------------------------------------------------------------------------------------------------------------|
| <ul style="list-style-type: none"> Akron 8, Ohio.....335 S. Main St. Albany 1, N. Y.....90 State St. Allentown, Pa.....1014 Hamilton St. Amarillo, Texas.....701 E. Fifth St. Atlanta 3, Ga.....167 Spring St., N.W. Bakersfield, Calif.....211 E. 18th St. Baltimore 1, Md.....39 W. Lexington St. Bangor, Maine.....77 Central St. Beaumont, Texas.....398 Pearl St. Binghamton, N. Y.....19 Chenango St. Birmingham 2, Ala.....600 N. Eighteenth St. Bluefield, W. Va. P.O. Box 447, Appalachian Bldg. Boston 1, Mass.....140 Federal St. Buffalo 3, N. Y.....535 Washington St. Butte, Mont.....20 West Granite St. Canton 1, Ohio.....700 Tuscarawas St., W. Cedar Rapids, Iowa.....203 Second St., S.E. Charleston 28, W. Va...306 MacCorkle Ave., S.E. Charlotte 1, N. C.....200 S. Tryon St. Charlottesville, Va.....123 E. Main St. Chattanooga 2, Tenn.....832 Georgia Ave. Chicago 80, Ill.....840 S. Canal St., P.O. Box 5970A Cincinnati 2, Ohio.....215 W. Third St. Cleveland 4, Ohio.....4966 Woodland Ave. Columbia 23, S. C.....1225 Washington St. Columbus 15, Ohio.....40 S. Third St. Dallas 2, Texas.....1801 N. Lamar St. Davenport, Iowa.....511 Pershing Ave. Dayton 2, Ohio.....25 N. Main St. Denver 2, Colo.....650 Seventeenth St. Des Moines, Iowa.....418 W. Sixth Ave. Detroit 2, Mich.....700 Antoinette St. Duluth 2, Minn.....14 W. Superior St. El Paso, Texas.....109 N. Oregon St. Erie 2, Pa.....10 E. Twelfth St. Evansville 19, Ind.....123 N.W. Fourth St. Fairmont, W. Va.....511 Jacobs Bldg. Fergus Falls, Minn.....102 W. Lincoln Ave., P.O. Box 197 Fort Wayne 2, Ind.....127 W. Berry St. Fort Worth 2, Texas.....408 W. Seventh St. | <ul style="list-style-type: none"> Fresno 1, Calif.....Tulare and Fulton St. Grand Rapids 2, Mich...148 Monroe Ave., N.W. Greenville, S. C.....106 W. Washington St. Hagerstown, Md.....Professional Arts Bldg. Hartford 3, Conn.....410 Asylum St. Houston 1, Texas.....1312 Live Oak St. Indianapolis 4, Ind.....110 N. Illinois St. Jackson, Mich.....120 W. Michigan Ave. Jackson 1, Miss.....203 W. Capitol St. Jacksonville 2, Fla.....237 W. Forsyth St. Jamestown, N. Y.....2 Second St. Johnson City, Tenn.....334 E. Main St. Johnstown, Pa.....841 Oak St. Kansas City 6, Mo.....106 W. Fourteenth St. Knoxville 08, Tenn.....602 S. Gay St. Lincoln 8, Neb.....1001 "O" St. Los Angeles 54, Calif.....212 N. Vignes St. Louisville 2, Ky.....455 S. Fourth St. Madison 3, Wisc.....111 S. Hamilton Manchester, N. H.....839 Elm St. Medford, Ore.....2015 E. Main St., P.O. Box 1349 Memphis 3, Tenn.....8 N. Third St. Miami 32, Fla.....25 S.E. Second Ave. Milwaukee 3, Wisc.....940 W. St. Paul Ave. Minneapolis 2, Minn.....12 S. Sixth St. Mobile 13, Ala.....54 St. Joseph St. Nashville 3, Tenn.....234 Third Ave., N. Newark 2, N. J.....744 Broad St. New Haven 6, Conn.....129 Church St. New Orleans 12, La.....837 Gravier St. New York 22, N. Y.....570 Lexington Ave. Niagara Falls, N. Y.....253 Second St. Norfolk 10, Va.....229 Bute St. Oakland 12, Calif.....409 Thirteenth St. Oklahoma City 2, Okla...119 N. Robinson St. Omaha 2, Nebr.....409 S. Seventeenth St. Pasco, Wash.....421 W. Clark St. Philadelphia 2, Pa.....1405 Locust St. Peoria 2, Ill.....410 Main St. Phoenix, Ariz.....435 W. Madison St. Pittsburgh 22, Pa.....535 Smithfield St. Portland 3, Maine.....477 Congress St. | <ul style="list-style-type: none"> Portland 7, Ore.....920 S.W. Sixth Ave. Providence 3, R. I.....Industrial Trust Bldg. Raleigh, N. C.....304 So. Salisbury St. Reading, Pa.....31 N. Sixth St. Richmond 17, Va.....700 E. Franklin St. Riverside, Calif.....3972 Main St. Roanoke 11, Va.....202 S. Jefferson St. Rochester 4, N. Y.....89 E. Ave. Rockford, Ill.....110 S. First St. Rutland, Vt.....38 1/2 Center St. Sacramento 14, Calif.....1107 Ninth St. St. Louis 2, Mo.....112 N. Fourth St. Salt Lake City 9, Utah.....200 S. Main St. San Antonio 5, Texas.....310 S. St. Mary's St. San Diego 1, Calif.....861 Sixth Ave. San Francisco 6, Calif.....235 Montgomery St. San Jose, Calif.....177 W. Santa Clara Ave. Savannah, Ga.....16 Drayton St. Seattle 11, Wash.....710 Second Ave. Shreveport 39, La.....803 Jordan St. Sioux City 13, Iowa.....507 Sixth St. South Bend 11, Ind.....112 W. Jefferson Blvd. Spokane, Wash.....S. 162 Post St. Springfield, Ill.....607 E. Adams St. Springfield 3, Mass.....1387 Main St. Syracuse 2, N. Y.....113 S. Salina St. Tacoma 1, Wash.....1019 Pacific Ave. Tampa 6, Fla.....1206 North A St. Toledo 4, Ohio.....420 Madison Ave. Trenton, N. J.....214 Hanover St. Tulsa 3, Okla.....320 S. Boston Ave. Utica 2, N. Y.....258 Genesee St. Washington 5, D. C.....806 Fifteenth St., N.W. Waterbury 89, Conn.....111 W. Main St. Waterloo, Iowa.....716 Water St. Wheeling, W. Va.....40 Fourteenth St. Wichita 2, Kan.....200 E. First St. Wilmington, Del.....1326 Market St. Williamston, N. C.....Town Hall Worcester 8, Mass.....507 Main St. York, Pa.....56 W. Market St. Youngstown 3, Ohio.....25 E. Boardman St. |
|---------------------------------------------------------------------------------------------------------------------------------------------------------------------------------------------------------------------------------------------------------------------------------------------------------------------------------------------------------------------------------------------------------------------------------------------------------------------------------------------------------------------------------------------------------------------------------------------------------------------------------------------------------------------------------------------------------------------------------------------------------------------------------------------------------------------------------------------------------------------------------------------------------------------------------------------------------------------------------------------------------------------------------------------------------------------------------------------------------------------------------------------------------------------------------------------------------------------------------------------------------------------------------------------------------------------------------------------------------------------------------------------------------------------------------------------------------------------------------------------------------------------------------------------------------------------------------------------------------------------------------------------------------------------------------------------------------------------------------------------------------------------------------------------------------------------------------------------------------------------------------------------------------------------------------------------------------------------------------------------------------------------------------------------------------------------|-----------------------------------------------------------------------------------------------------------------------------------------------------------------------------------------------------------------------------------------------------------------------------------------------------------------------------------------------------------------------------------------------------------------------------------------------------------------------------------------------------------------------------------------------------------------------------------------------------------------------------------------------------------------------------------------------------------------------------------------------------------------------------------------------------------------------------------------------------------------------------------------------------------------------------------------------------------------------------------------------------------------------------------------------------------------------------------------------------------------------------------------------------------------------------------------------------------------------------------------------------------------------------------------------------------------------------------------------------------------------------------------------------------------------------------------------------------------------------------------------------------------------------------------------------------------------------------------------------------------------------------------------------------------------------------------------------------------------------------------------------------------------------------------------------------------------------------------------------------------------------------------------------------------------------------------------------------------------------------------------------------------------------------------------------------------------------------------------------------------------------------|------------------------------------------------------------------------------------------------------------------------------------------------------------------------------------------------------------------------------------------------------------------------------------------------------------------------------------------------------------------------------------------------------------------------------------------------------------------------------------------------------------------------------------------------------------------------------------------------------------------------------------------------------------------------------------------------------------------------------------------------------------------------------------------------------------------------------------------------------------------------------------------------------------------------------------------------------------------------------------------------------------------------------------------------------------------------------------------------------------------------------------------------------------------------------------------------------------------------------------------------------------------------------------------------------------------------------------------------------------------------------------------------------------------------------------------------------------------------------------------------------------------------------------------------------------------------------------------------------------------------------------------------------------------------------------------------------------------------------------------------------------------------------------------------------------------------------------------------------------------------------------------------------------------------------------------------------------------------------------------------------------------------------------------------------------------------------------------|

Hawaii: W. A. Ramsay, Ltd., Honolulu

Canada: Canadian General Electric Company, Ltd., Toronto

APPARATUS DEPARTMENT, GENERAL ELECTRIC COMPANY, SCHENECTADY, N. Y.