



**Electronic
TUBES**

G-E HAM NEWS

Copyright 1955, by General Electric Company
-If You Didn't Get This From My Site,
Then It Was Stolen From...
www.SteamPoweredRadio.Com

TUBE DEPARTMENT
GENERAL ELECTRIC
Schenectady 5, N. Y.

SEPTEMBER-OCTOBER, 1955

VOL. 10-NO. 5

A 6-METER SPECTACULAR—Part II "SIMPLE-SIXER" CONVERTER

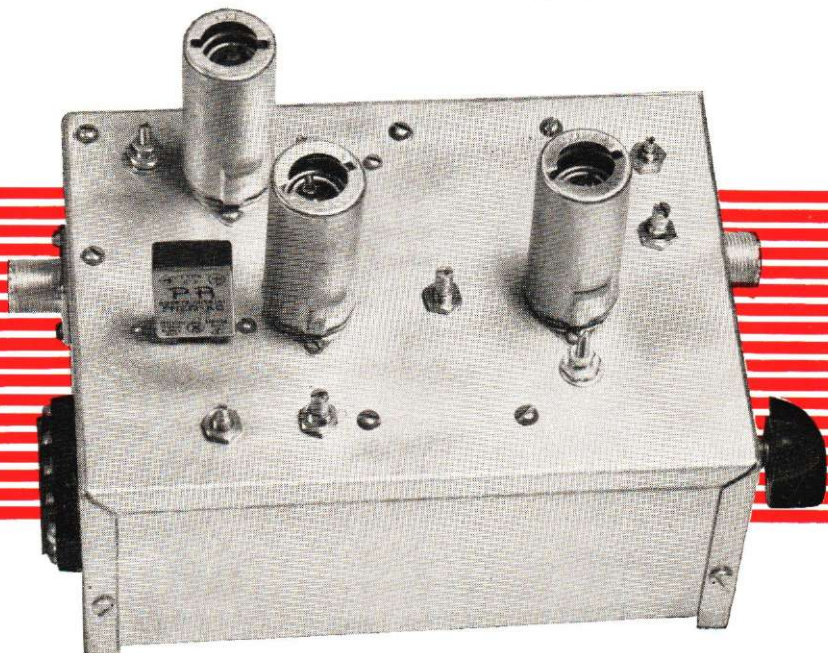

Part II is a 6-meter crystal-controlled converter that digs right down into the external noise level picked up by your antenna—rejects intermediate frequency range signals—and at the same time is simple to build and adjust. When used with the "Bonus 100" transmitter to be described in the next issue and a rotary beam antenna, some surprising contacts can be made.

—Lighthouse Larry

CONTENTS

"Operation Crystal"	page 2
"Simple-Sixer" converter	page 3
Sweeping the Spectrum	page 7
1955 Edison Radio Amateur Award	page 8



OPERATION CRYSTAL



The idea for this twin crystal receiver, which uses two of everything except grounds and pairs of ear-phones, came from Edmon L. Anderson, Moorpark, California. The three-gang 15-400-mmf broadcast band type variable capacitor, shown at right, tunes both detector circuits and the series-tuned ground circuit. A single variable air or mica-padded capacitor helps make the ground circuit tuning track. After a station is tuned in, some interesting variations in carrier and audio signal strength can be obtained by tuning the slugs in Vari-loopstick coils L_1 and L_2 . A definite reduction in signal strength was noted when one crystal diode was disconnected after first peaking all the adjustments for maximum signal with both parts of the circuit working. If you try this test, do not expect to detect any startling differences by ear. In making these tests, I find that an oscilloscope used as a peak-to-peak audio voltmeter and the low voltage

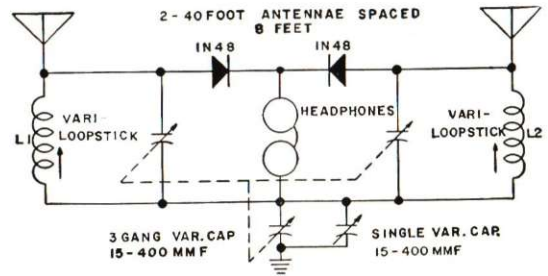

ranges on a vacuum tube voltmeter are necessary to evaluate the merit of most circuits. Erecting the extra antenna 8 feet from my original test antenna was a simple task because Mother Nature correctly placed the necessary trees at the test location.

Pi-networks are getting into the act in every corner of amateur radio these days! If you haven't thrown away those old 3- or 4-gang broadcast set variable capacitors that probably have been kicking around in your junk-box for several years, stick them into this Canadian pi-network crystal receiver dreamed up by E. J. Epp, VE3AJY, of Armstrong, Ontario. A single-gang capacitor with a few 500-mmf fixed capacitors that can be switched across it with a tap switch also will work for both C_1 and C_2 , pictured at the right. If you have plenty of No. 30 wire, tap switches and ambition, you can build your own coil by winding 180 turns, tapped every 10th turn, on a 1 1/4-inch diameter form. Or, substituting a Vari-loopstick coil will give you just about the same results, but look at all the fun you will miss by not winding and tapping those 180 turns. Both audio voltage and direct current through the headphones were somewhat higher than with a conventional

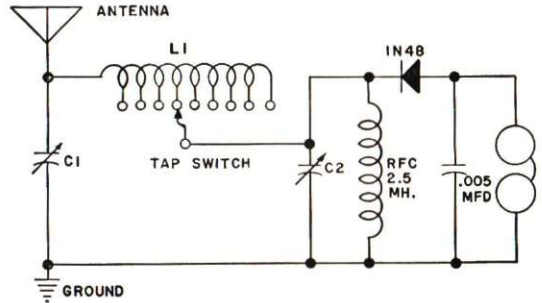

tuned circuit because of an improved impedance match at both ends of the pi-network when properly adjusted.

Here's an idea, also pictured at the right, for making a combination signal tracer and crystal radio receiver, submitted by J. L. Walty, of Walla Walla, Washington. The circuit is built into a small plastic box about 3 x 2 x 1 inches, with a probe on one end made from a 1 1/2-inch long brass machine screw.

If your pet crystal receiver circuit can be squeezed into a small box, use it instead of Mr. Walty's simple one using just a slug-tuned Vari-loopstick coil. The 300-mmf coupling capacitor from the probe to the coil is necessary to keep DC voltages out of the circuit when tracing a plate circuit signal. The ground clip lead should be connected to the chassis when signal tracing, or an earth ground for crystal receiver operation. An outside antenna should be hooked on the probe when using this gadget as a radio.

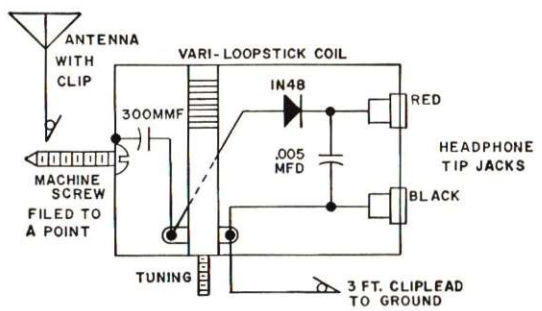

All ideas submitted before December 1, 1955, will be eligible for publication in the OPERATION CRYSTAL Column. (See G-E HAM NEWS, Volume 10, No. 1, for details.) Do not send in your model!! Submitters of the three ideas published in each issue receive certificates for \$10 in G-E electronic tubes. Construction and simple antenna hints of an outstanding nature are also eligible. All material submitted must be free of patent restrictions and becomes the property of G-E HAM NEWS.

—Danny Diode

"SIMPLE-SIXER" CONVERTER

Here's a 6-meter crystal-controlled converter designed especially for the radio amateur who has *tasted* this band with the *bare essentials* and is now ready for equipment that will enable him to explore the interesting possibilities of the 50- to 54-megacycle range to the fullest extent.

Why use a cascode circuit on 6 meters? The lower noise figure of this type circuit over conventional pentode RF amplifiers will not be noticed at many locations at which the local noise level is high. But, local noise may be substantially lower during those early daylight or late evening hours when tropospheric-bending propagation is often present. That last 2 or 3 db reduction of internal noise in this converter will help you complete many extended ground wave contacts during those periods.

The stability problem encountered in using a converter with a tunable oscillator for this band is easily licked by using the fifth overtone of an 8-megacycle crystal to provide a 40-megacycle mixing signal without resorting to frequency multipliers after the oscillator. The resulting 10- to 14-megacycle intermediate frequency range was selected after surveying the tuning ranges of most popular communications receivers. BC-348 and SX-96 receiver owners will find that crystal oscillator output frequencies of 40.5 and 41 megacycles respectively, will allow the 6-meter band to be covered in one tuning range.

The electrical bandspread tuning dial on receivers having them can be juggled to make the main tuning dial read the correct tuning range if you wish to use a crystal not precisely 8 megacycles.

Performance requirements for the receiver into which the converter works can best be described by the old saying, "The merit of a radio receiver is not in what it will receive, but in what it will not receive." If your receiver is sufficiently well shielded to be almost "dead" in this range with the antenna and ground disconnected, you are already in business.

Replacing the receiver antenna terminal strip with a coaxial cable jack will reduce unwanted signal pickup from this source in many cases. Or, the jack could be mounted on a small aluminum box that encloses the antenna terminals if you do not wish to alter your receiver. (If you solve the problem of tightening the antenna terminal screw when the box is in place, send in a description to our "Tricks and Topics" column.)

CIRCUIT DETAILS

The antenna input impedance matching arrangement shown in the schematic diagram, Fig. 1, also used in the G-E HAM NEWS "R-9'er" (See Volume 1 No. 4, for details), simplifies adjustment of the antenna coupling to the RF amplifier input circuit (L_1-C_1).

The double-tuned tank circuit shown below at "A" is actually the equivalent of circuit "B." These units are easily made from a single, tapped length of B & W *Miniductor* coil material with the ends connected to

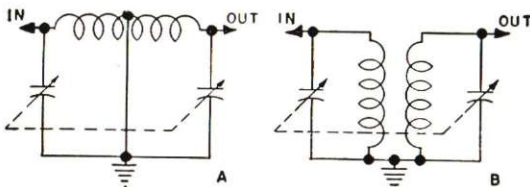

the stator sections of a *Johnson type M* midget butterfly variable capacitor. The two units used in the RF amplifier grid (L_1-C_1) and plate (L_2-C_2) circuits were stagger-tuned to provide a flat-topped response curve about 4 megacycles wide when the converter was checked with standard television receiver RF alignment equipment. These tank circuits also have good *skirt* selectivity, which helps prevent strong signals in the 10- to 14-megacycle intermediate frequency range from feeding through the converter.

The simplified cascode RF amplifier circuit using a 6BK7A gives about the same rejection to a 10-megacycle test signal fed into antenna jack J_1 as a more complicated circuit using an extra tuned circuit between the two cascode tube sections. Use of shields on all tubes also helps prevent direct intermediate frequency signal pickup.

The pentode half of a 6U8 works as a mixer, with the triode functioning as an overtone crystal oscillator. The pi-network (L_4, C_4, C_5) feedback arrangement allows considerable flexibility in crystal choice. Inexpensive third-overtone 24-megacycle or most 8 megacycle fundamental frequency crystals have satisfactory output at the 40-megacycle fifth overtone, avoiding the need for the more costly VHF crystals.

Another 6U8 pentode section intermediate frequency amplifier feeds the triode section, used as a cathode follower output stage. The two intermediate frequency plate circuit coils (L_5 and L_6) are stagger-tuned for improved band-pass in the 10- to 14-megacycle range. Some inexpensive receivers which may be used as the tunable intermediate frequency section have no RF amplifier. The intermediate frequency amplifier built into the converter insures sufficient gain to overcome this limitation. A gain control which varies the cathode bias on this stage permits the converter output to be adjusted for best performance without overloading even "hot" receivers. Heater and plate power can be obtained from any source capable of supplying 6.3 volts at 1.2 amperes and 200-250 volts DC at 40 milliamperes.

CONSTRUCTION

The difficult task of working in the tight corners of a small conventional chassis was avoided by building the converter on the half of a 3 x 5 x 7-inch aluminum "channel-lock" type two-piece utility case having the 3- x 5-inch ends. The parts layout was determined after much *cut-and-try* and should be followed closely. The padder capacitor, coil forms, tube and crystal sockets and terminal strips mount on the top of this box in the locations marked on the chassis drilling diagram, Fig. 2. The gain control and antenna input coaxial cable jack (J_1) are located on one end plate $1\frac{1}{2}$ inches down from the top and $1\frac{1}{4}$ inches in from the side corners. The output jack (J_2) and a 3-screw terminal connection strip occupy the other end.

A small shield made from $\frac{3}{8}$ -inch thick soft sheet aluminum $4\frac{3}{4}$ x $3\frac{3}{8}$ inches separates L_5, L_6, J_2 and the intermediate frequency amplifier tube socket from the VHF circuits. The metal is folded so that the long side is 2 inches long, the short wall $1\frac{1}{2}$ inches wide, with a $1\frac{1}{4}$ -inch long wall placed at an angle between them. Two small $\frac{1}{4}$ -inch wide flanges are formed on the side adjacent to the top of the chassis for mounting with 4-40 x $\frac{1}{4}$ -inch long machine screws, as shown in the bottom view, Fig. 3. The shield should be trimmed to fit snugly against the other half of the utility case when it is assembled. The top corner at each end of the shield is cut off to permit wiring to enter the intermediate frequency compartment.

The shield should be mounted after all connections except the wire from plate pin 6 of the 6U8 mixer tube socket to the lower end of L_5 are completed. This lead passes through a $\frac{1}{4}$ -inch diameter hole in the

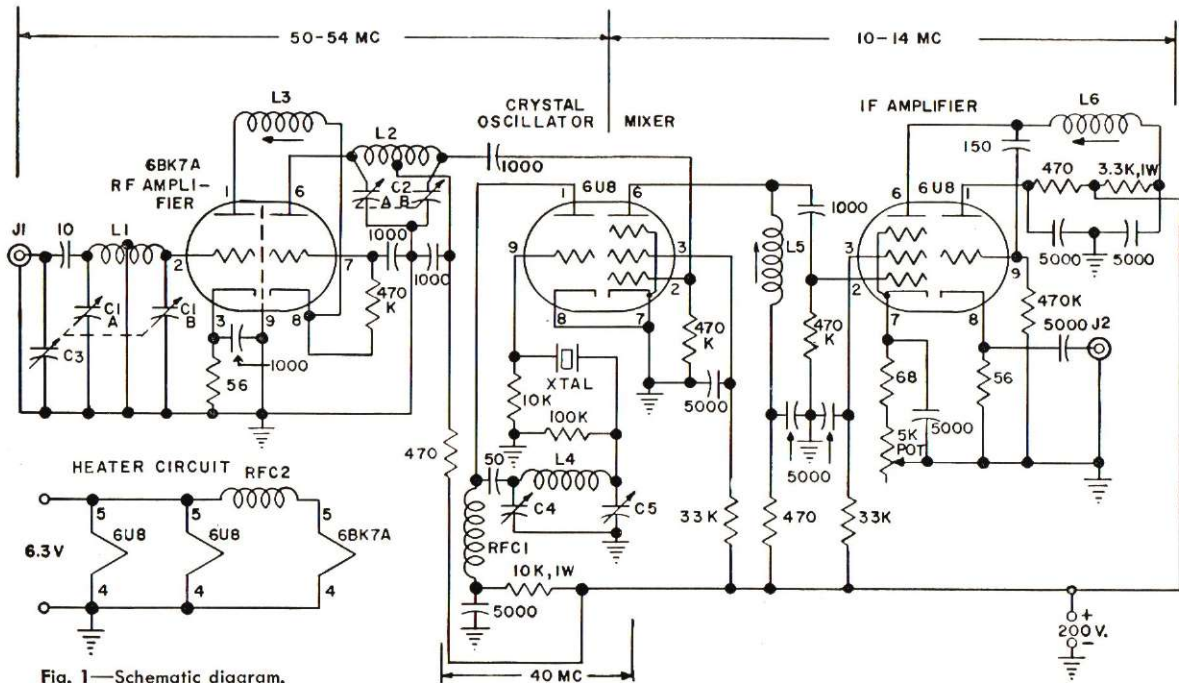

Fig. 1—Schematic diagram.

PARTS LIST

C₁, C₂—2.2–8.0-mmf butterfly variable capacitors (Johnson 9MB11 Cat. 160–208)
 C₃, C₄—15–130-mmf variable mica padder capacitor (El Menco 302)
 C₅—1.8–8.7-mmf single midget variable capacitor (Johnson 9M11 Cat. 160–104)
 RFC₁, RFC₂—Ohmite Z-50 RF Chokes
 Xtal—Quartz crystal, 8,000 or 24,000 megacycles
 All capacitors in mmf, 600-volt disc ceramic
 All resistors ½-watt, unless otherwise specified

COIL TABLE

L₁, L₂ and L₄ made from B & W Miniductors, Type 3007, 3/8-inch diameter, 16 turns per inch
 L₁—9 turns with 3/4-inch leads, tapped at 4 turns from antenna end
 L₂—10 turns with 3/4-inch leads, center-tapped
 L₃—CTC Type LS-3 blank coil form close-wound with 20 turns of No. 26 enameled wire
 L₄—14 turns with 1/2-inch leads
 L₅, L₆—CTC Type LS-3 10-megacycle coils, as-is (Cambridge Thermionic Corp.)

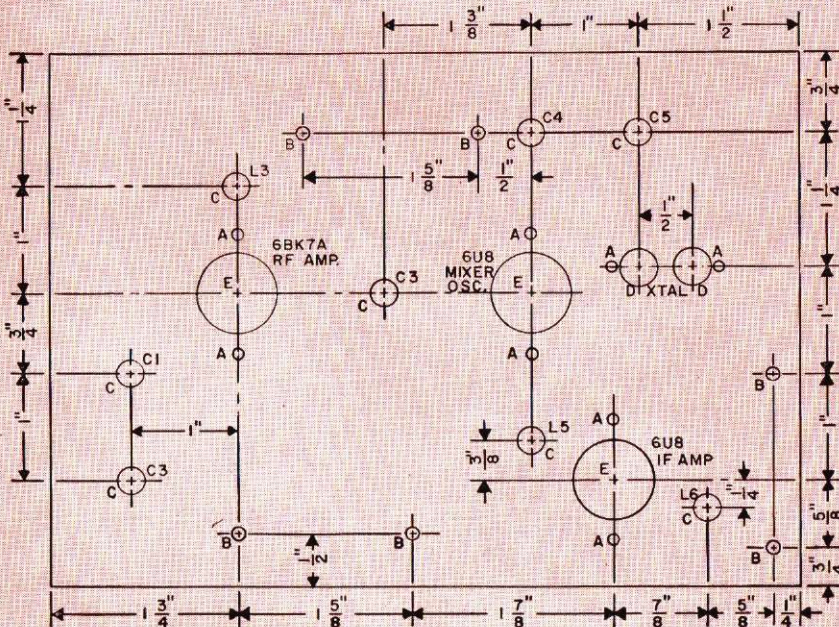

DRILL LEGEND

"A" drill—No. 32 spaced to suit sockets
 "B" drill—No. 26 for terminal strips
 "C" drill—1/4-inch diameter
 "D" drill—3/8-inch diameter for crystal socket
 "E" socket punch—1/4-inch diameter

4 Fig. 2—Drilling diagram of the 6-meter converter.

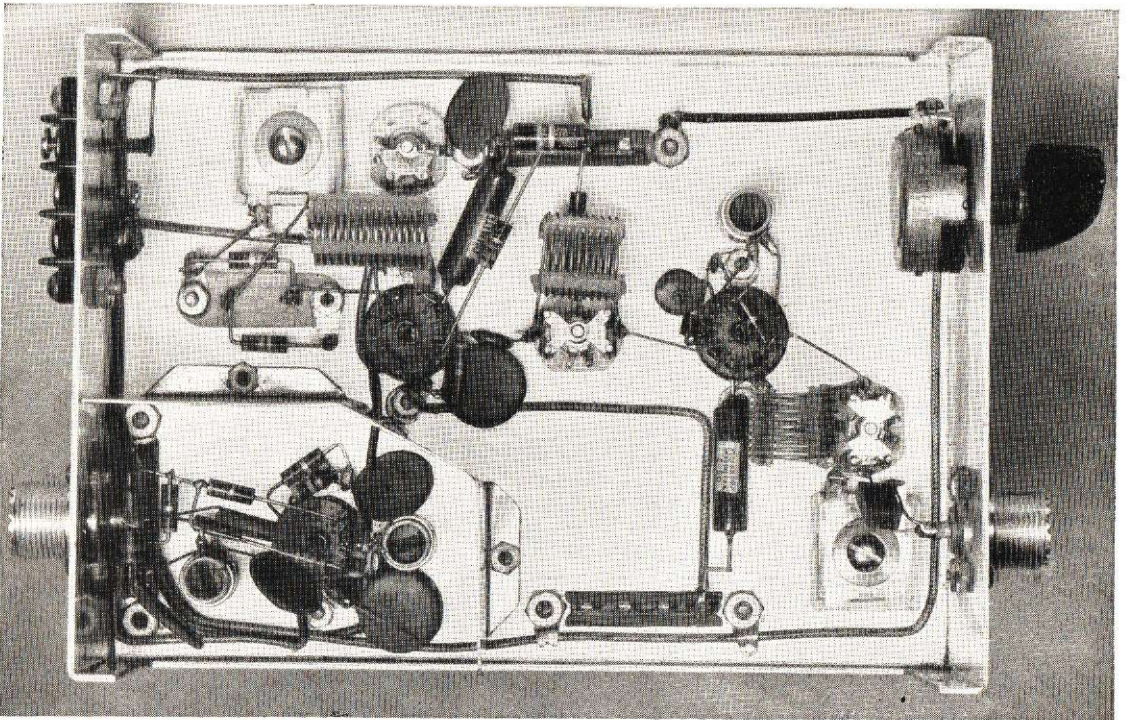

Fig. 3—Bottom view of the 6-meter converter showing placement of the shield around the intermediate frequency amplifier and positioning of coils.

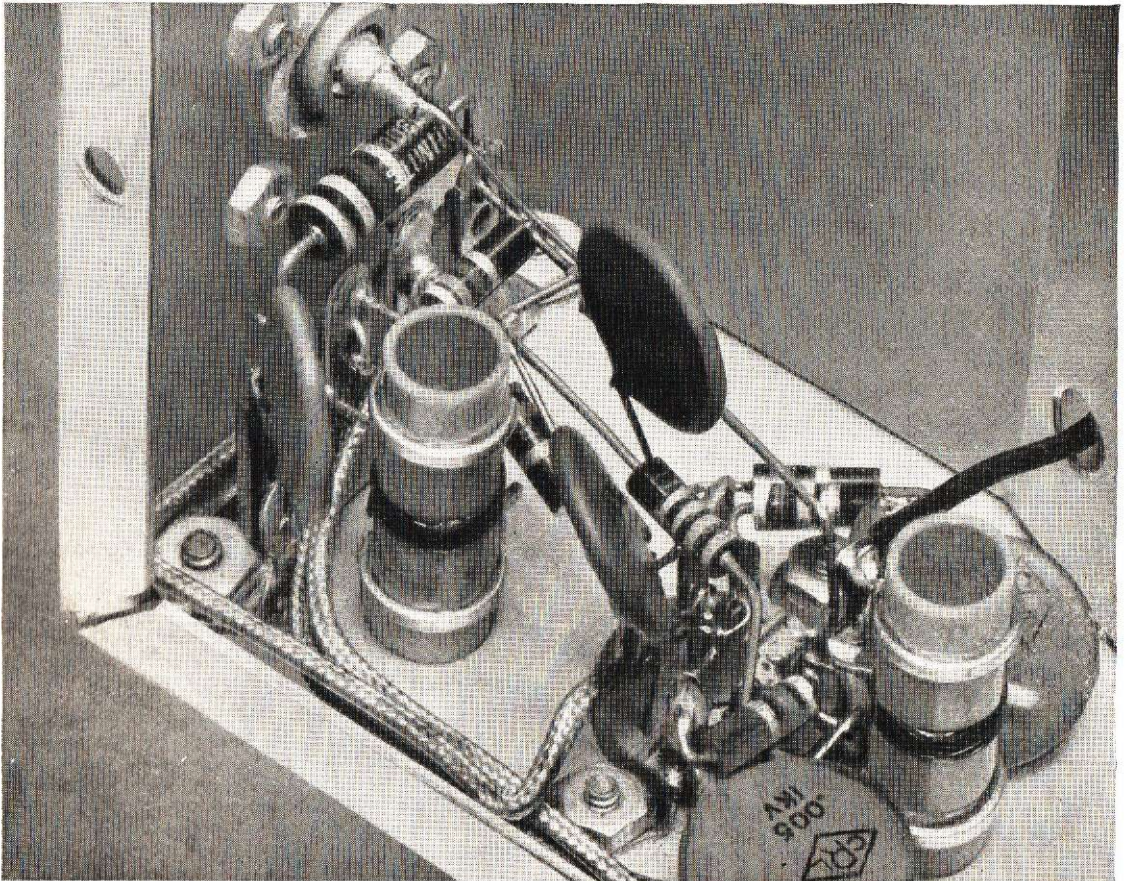

Fig. 4—Intermediate frequency amplifier compartment view.

shield, pictured in the compartment view, Fig. 4. The soldering terminals on L_5 and L_6 should not be moved when assembling and wiring these coils or the fine wire leads may be damaged.

All resistors except the cathode bias and grid-to-ground units mount on the three 4-terminal Cinch-Jones 2000-4 mounting strips placed at convenient locations. By-pass and coupling capacitors fasten directly on their associated parts and to ground terminal lugs placed under all the 4-40 x $\frac{1}{4}$ -inch long machine screws holding the tube sockets, coaxial cable connectors and terminal strips to the chassis.

All heater, plate power and gain control connecting leads run near the corners of the chassis. However, keep these wires and all other parts at least $\frac{1}{8}$ -inch away from these corners so that the other half of the case can be assembled without interference.

Duplication of band-pass transformers L_1-C_1 and L_2-C_2 is simplified by making the coils from standard Miniductor material and using the midget butterfly variable capacitors for fine tuning adjustments. The coil used for L_2 should be tapped as shown in the coil table on page 4 by bending in the coil-turn each side of the tap enough to prevent it from becoming shorted when one lead from the 1000-mmf ceramic disk by-pass capacitor is soldered to the proper coil-turn. One lead of a 470-ohm resistor also connects to this coil-tap. The other end of this resistor extends to the plate voltage lug on the nearest terminal strip. The other by-pass capacitor lead connects directly to the rotor ground lug on C_2 . The ends of the coil then connect to the stator lugs on C_2 with leads just long enough to allow the coil to clear the capacitor rotor when it is tuned. The completed transformer assembly is pictured in Fig. 5.

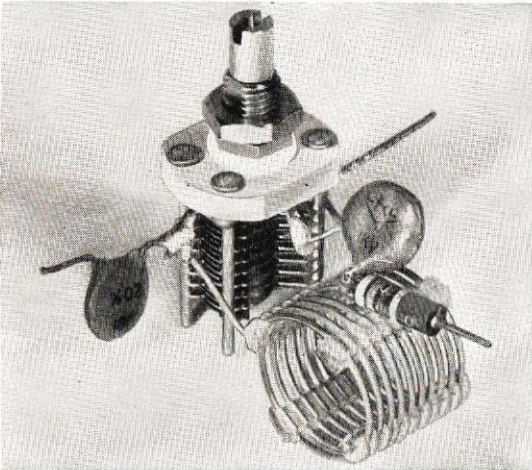

Fig. 5—Detail view of RF transformer L_2-C_2 . L_1-C_1 is identical except that no resistor and by-pass capacitor is used on the coil-tap.

Transformer C_1-L_1 is assembled in the same manner, except that a short length of wire is attached to the coil-tap for a direct ground connection to the rotor lug on C_1 . Make sure the coils have no shorted turns before mounting the completed assemblies on the chassis. One stator lug on C_2 connects to plate pin 6 on the 6BK7A, the other lug goes to pin 2 of the 6U8 mixer through a 1000-mmf coupling capacitor. Corresponding lugs on C_1 connect to pin 2 on the 6BK7A and through a 10-mmf coupling capacitor to the ungrounded lug on C_3 . All RF and by-pass connections should be made with shortest possible wires.

Power should be applied to the converter and the heater voltage measured before inserting the 6U8 mixer-oscillator tube. Next, a tube shield is placed over the 6U8 and an appropriate crystal plugged into the proper socket. With C_5 set about one turn from maximum capacity, plate voltage is next applied. A No. 48 or 49 (2.0 volt, 60 ma) pilot bulb with a 1-inch diameter wire loop soldered to the base terminals or a small neon bulb, is then held near L_4 , and C_4 is slowly tuned near maximum capacity until the bulb lights. Feedback capacitor C_5 should then slowly be turned toward maximum capacity until oscillation stops, then toward minimum capacity until oscillation again begins.

The oscillator frequency should next be checked with a calibrated wavemeter or receiver tuning the 40-megacycle range to insure that the oscillator is working on the correct overtone. Settings of C_5 will be near maximum capacity for overtone crystals and about one turn from maximum for fundamental crystals. Self-oscillation may be noted near the minimum capacity setting of C_4 when too much feedback is used.

The output of the converter is now connected to the station receiver through a length of coaxial cable and the 6U8 intermediate frequency amplifier tube and shield inserted. A signal generator or grid-dip oscillator covering both the 50 to 54 and 10- to 14-megacycle ranges is handy for aligning the remaining tuned circuits. Once the converter crystal oscillator is working, the station receiver can be used to check the calibration on both ranges of these instruments. L_5 and L_6 should be peaked at 11 and 13 megacycles respectively, using a signal fed into pin 2 of the 6U8 mixer.

The bottom half of the box should now be assembled and the 6BK7A tube and shield inserted. A short length of 52-ohm coaxial cable is then plugged into the antenna connector and a 56-ohm composition resistor wired across the other end. The signal source coupled to this cable is then set to 52.5 megacycles and C_2 is tuned for maximum signal.

The antenna input circuit, L_1-C_1 , antenna matching capacitor C_3 and neutralizing coil L_3 can next be adjusted for lowest noise figure using a noise generator, such as the one described on page 2 of the September-October, 1954, issue of G-E HAM NEWS. If a noise generator is not available, C_1 is adjusted for maximum signal when the test source is set at 50.5 megacycles.

Then, L_3 can be adjusted for *minimum* signal feed-through by temporarily disconnecting heater voltage from the 6BK7A. Adjustment of L_3 for best noise figure and the signal null is fairly broad at 50 megacycles. The heater power lead is again connected to the 6BK7A and C_3 is set for maximum signal at 50.5 megacycles. C_1 may need a slight readjustment for maximum response after matching the antenna impedance. A noise figure reading of 4 db was obtained on the test model on a laboratory-type noise generator using both the above alignment methods.

A shielded power connection cable will minimize intermediate frequency range signal pickup from this source. When an unshielded cable was used during tests, nearby short-wave broadcast stations in the 11.8-megacycle band were distinctly audible until a 1-mh RF choke was inserted in the positive plate lead *outside* the converter case at the terminal strip.

Best reception can only be obtained if an efficient antenna is used. A large rotary beam, such as a 2 or 3 bay stack of 4 or 5 element Yagi antennas, pays big dividends on the 50-megacycle band. They can be mounted on a few television antenna mast sections and braced with guy wires connected to a rotating guy ring placed just below the top bay. Each bay can be made from a "stretched" bargain-priced channel 2 television antenna.

SWEEPING *the* SPECTRUM



Calling all would-be transistor experimenters! If price has prevented you from trying some of the audio and low-frequency RF transistor circuits recently published, the Semi-conductor department of the G-E Electronics Division has come to your rescue with a new, inexpensive PNP junction transistor, the 2N107. They are now available on a display card at most G-E electronic tube distributors in a convenient package of two. Included in the package, which sells for little more than a carton of cigarettes, is a booklet showing several simple audio voltage amplifier, speaker output amplifier, code-practice oscillator, radio receiver and TV antenna orientation meter circuits. They require only a few parts, plus two to four ordinary flashlight cells for power. Use them for a microphone preamplifier which will have no hum problems from AC tube heaters. They will operate in RF applications up to one megacycle. Try a package soon.



Remember the flood of comments and ideas I received for the Tricks and Topics Column four or five years ago about the "How to get the nut on the almost inaccessible bolt trick?" A *king-sized* example of a similar situation recently came to my attention in the Camera Tube section of the G-E Power Tube factory here at Schenectady.

In the assembly of the GL-5820 image-orthicon type television camera tube, the *target* assembly must be lowered through the neck to its final position near the faceplate with the tube standing on end. Then, small clamping screws must be carefully tightened, using screwdrivers 18 inches long, without having any dust enter the tube during this operation.

Delicacy of this assembly can be emphasized by the fact that the target consists of a 0.00015-inch thick circle of glass separated 0.002 inches from a 500 wire-per-inch circular copper screen mesh by a spacer ring. Tiny rivets fasten the mesh to the spacer. One slip of a screwdriver and this microscopically thin glass circle shatters into tiny fragments that cannot be removed from the tube. This is only one of many precision operations necessary to assemble the 256 parts of a tube that engineers throughout the tube industry heartily agree is about the most difficult to manufacture.



Supply of the first bound volume of G-E HAM NEWS, which contained all issues from Volume 1, No. 1 to Volume 5, No. 6, has been exhausted. A second bound volume, which will contain all issues from Volume 6, No. 1, to Volume 10, No. 6, will be published during 1956. Over two hundred people have already asked to be placed on the list reserving a copy for them. If you would like to be notified when this second bound volume will be available, send in your name and mailing address, but please do *not* make any remittance at this time.

Letters in the titles of all the radio club periodicals and bulletins regularly received at the G-E HAM NEWS office would make a good-sized pot of alphabet soup. After browsing through a stack that the editor passed on to me, I notice that "SPARKS" and "NEWS," preceded by the name of the club, seem to be the most popular titles, by far. Some of the more enterprising papers even run a cross-word puzzle!

Seriously, receipt of all these publications enables me to get a pretty good idea of just what is going on, activity-wise, in the far-flung areas of ham-dom. Keep sending them in, fellows!!

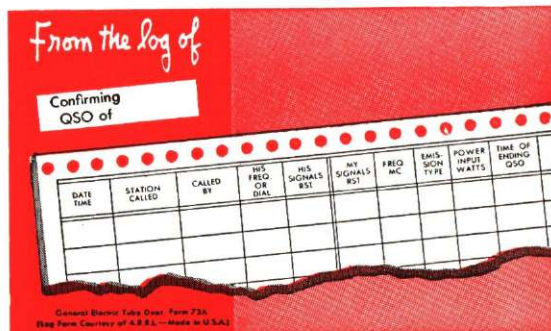

Response to my request for opinions on how you liked the idea for the G-E HAM NEWS QSL card (shown above again just in case you missed the picture of it in the last issue) has been terrific. Your answers rolled in by letter, postcard, QSL card and radiogram saying—overwhelmingly . . . YES!! Consequently, packages of 300 QSL cards now are available, for only one dollar, delivered postpaid to your door. We have had the printer wrap them, ready to ship, in packages of 300. Please order them in that quantity, or multiples of it. At this price, we cannot accept orders requesting C.O.D. shipment or billing at a later date. Kindly enclose full remittance with your order.

Radio amateurs in the United States, Canada, Alaska, Hawaii and the Panama Canal Zone should make checks or money orders payable to: Tube Department, General Electric Company, Schenectady 5, New York. In all other countries, write: Lighthouse Larry, International General Electric Company, 570 Lexington Avenue, New York 22, New York.

Several short-wave listeners also voted for these QSL cards, adding another idea to the list of suggested uses we printed in the last issue. Note that there is plenty of space above and below the log form for your call letters, address and remarks. To all those who expressed interest in this project by sending in their comments—A MILLION THANKS!!

—Lighthouse Larry



NOMINATIONS NOW OPEN FOR 1955 EDISON AWARD

The Fourth Annual Edison Radio Amateur Award will give you an opportunity to recommend for high honors an amateur who has rendered important public service.

Handsome trophy, a \$500 check, and coast-to-coast recognition await the 1955 winner. The panel of judges will consider only candidates nominated by letters from you and others.

Start now to make your selection and assemble the facts for your nominating letter. Read the Award Rules below

Radio Amateurs and their friends are generous in acclaiming accomplishment. No better means for this exists than for you to name . . . soon . . . a candidate for the Edison Award. Send your letter to Edison Award Committee, General Electric Company, Tube Department, Schenectady 5, N. Y.

RULES OF THE AWARD

WHO IS ELIGIBLE. Any man or woman holding a radio amateur's license issued by the F.C.C., Washington, D.C., who in 1955 performed a meritorious public service in behalf of an individual or group. The service must have been performed while the candidate was pursuing his hobby as an amateur within the continental limits of the United States.

WINNER OF THE AWARD will receive the Edison trophy in a public ceremony in a centrally located metropolitan city. Expenses of his trip to that city will be paid.

\$500 GIFT. Winner will be presented with a check for this amount in recognition of the public service he has rendered.

WHO CAN NOMINATE. Any individual, club or association familiar with the service performed.

HOW TO NOMINATE. Include in a letter the candidate's name, address, call letters, and a full description of the service performed. Your letter must be postmarked not later than January 2, 1956.

BASIS FOR JUDGING. All entries will be reviewed by a group of distinguished and impartial judges. Their decisions will be based on (1) the greatest benefit to an individual or group (2) the amount of ingenuity and sacrifice displayed in performing the service.

JUDGES WILL BE

E. ROLAND HARRIMAN, President, The American Red Cross.
HERBERT HOOVER, JR., the Under Secretary, U.S. Department of State.

EDWARD M. WEBSTER, Commissioner, Federal Communications Commission.

GOODWIN L. DOSLAND, President, American Radio Relay League.

Winner of the Award will be announced on or before Thomas A. Edison's birthday, February 11, 1956.

Employees of the General Electric Company may nominate candidates for the Edison Radio Amateur Award, but are not permitted to receive the Award.



G-E HAM NEWS

Available FREE from

G-E Electronic Tube Distributors

published bi-monthly by

TUBE DEPARTMENT

GENERAL  ELECTRIC

Schenectady 5, N. Y.

In Canada
Canadian General Electric Co., Ltd.
Toronto, Ontario

E. A. NEAL, W2JZK—EDITOR

SEPTEMBER—OCTOBER, 1955

Printed in U.S.A.

VOL. 10—NO. 5

If You Didn't Get This From My Site,
Then It Was Stolen From...

www.SteamPoweredRadio.Com