



Electronic
TUBE

Ham News



Copyright 1951, by General Electric Company

JULY—AUGUST 1951

If You Didn't Get This From My Site,
Then It Was Stolen From...

VOL. 6—NO. 4

www.SteamPoweredRadio.Com

SIGNAL SLICER

Four Tube Receiver Adapter for Improved Reception
of AM, NBFM, CW or SSB Signals

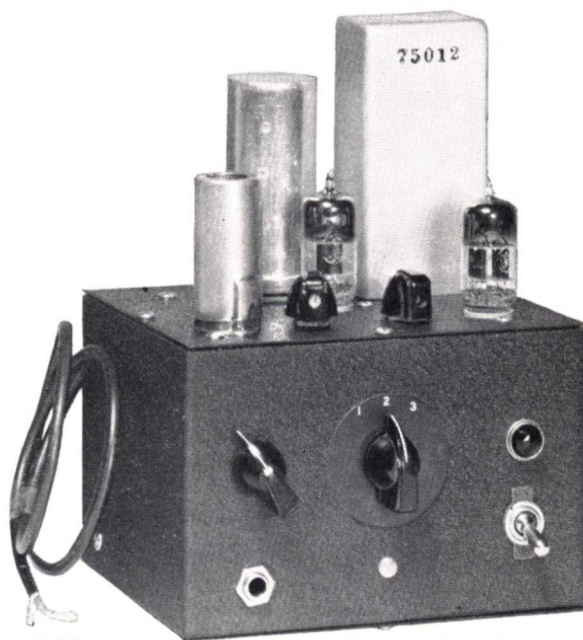

FORT ORANGE RADIO DISTRIBUTING CO., INC.

Fig. 1. Front view of the Signal Slicer. The input cable is at the left of the unit.

Ever since the SSB, Jr. transmitter appeared in the G-E Ham News my readers have been asking whether it would be possible to design a simplified receiver adapter incorporating the same simple phase-shift network. The Signal Slicer described in this issue is W2KIJ's answer to those questions.

—Lighthouse Larry

ANOTHER
G-E HAM NEWS
SSB SPECIAL

Contents

Signal Slicer.....	pages 1-9
Designer's Corner.....	page 10
Sweeping the Spectrum.....	page 11
Germanium Diodes (condensed specifications).....	page 12

SIGNAL SLICER

The Signal Slicer is a complete receiver adapter for converting the conventional communications receiver having 450-500 kilocycle I-F to a single-sideband receiver. The system utilized to obtain single-sideband response is of the phase-shift type, utilizing either a commercially made or a home-built phase-shift network of the type described for the SSB, Jr., transmitter (G-E *Ham News*, Vol. 5, No. 6). The name Signal Slicer has been applied to this adapter because of its ability to slice the selectivity curve of the conventional receiver in two, permitting one to listen at will to signals in either the upper or lower frequency portion of the receiver's normal I-F selectivity curve.

In contrast to the original SSB receiver adapter (G-E *Ham News*, Vol. 3, No. 6) the Signal Slicer requires no vacuum-tube probe, utilizes only four double-purpose tubes, and has no carrier synchronizing circuit. Notwithstanding a rather drastic reduction in its complexity, this adapter is a practical answer to the question, "Why not describe a simplified single-sideband receiver adapter?"

The Signal Slicer, when attached to a communications receiver, gives you a combination which permits you to do away with at least fifty percent of the QRM when receiving conventional AM or phase-modulated phone signals. The same holds true for the reception of CW signals, with the Signal Slicer supplying the heterodyning signal so that the BFO in the communications receiver is not required. True single-signal

reception of CW signals is possible with this combination.

For reception of single-sideband signals, this adapter furnishes a carrier against which the sidebands may be demodulated. By selecting the proper sideband with a switch, the modulation may be read. Although it is now pretty well understood that a special adapter is not required for reception of single-sideband signals, many amateurs who have heard or used the original *Ham News* SSB receiver adapter appreciate the benefits of such a device.

CIRCUIT DESCRIPTION

The complete circuit diagram for the Signal Slicer is shown in Fig. 2. As is the case for most equipment described in the *Ham News*, an effort has been made to utilize completely standard components wherever possible. The built-in power supply is a conventional voltage doubler with a selenium rectifier and a conventional resistance-capacitance filter. No further comment on this portion of the circuit is necessary except to point out that a transformer is used to isolate the circuits from the a-c line in order to prevent interconnection problems between the adapter and the communications receiver.

The phase-shift type of adapter consists basically of two detectors (demodulators) supplied by a signal to be received and signals from an oscillator which acts as a local carrier source. The outputs of the

Electrical Circuit

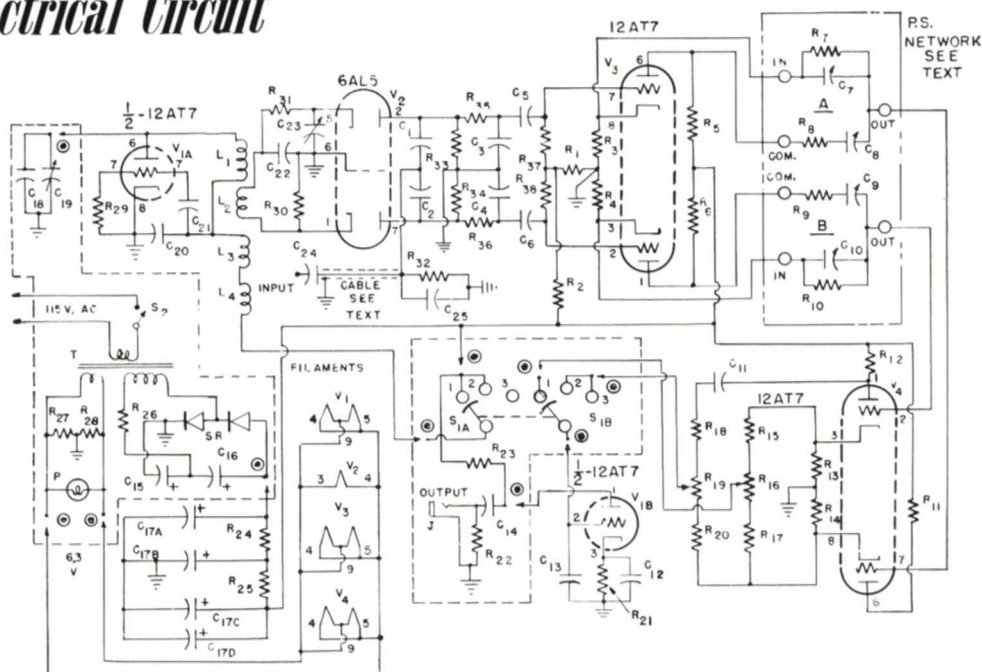

Fig. 2. Circuit diagram of the Signal Slicer.

separate demodulators are fed through a pair of phase shifters of such characteristics that the algebraic sum of their outputs consists of audio signals created by I-F signals which lie on one side of the local oscillator frequency, and the algebraic difference consists of audio signals created by I-F signals which are on the other side of the local oscillator frequency.

In the Signal Slicer half of the double triode V_1 is used as a Colpitts oscillator whose output is coupled into the two halves of the double-diode V_2 acting as the two demodulators. These demodulators are also supplied with signals from the I-F amplifier of the receiver with which the adapter is used. The demodulator outputs are supplied to the double triode V_3 which in turn feeds two phase-shift networks (Millen No. 75012 or a home-made equivalent).

The outputs of the phase-shift networks are then applied to the two triode sections of V_4 whose outputs are fed to the combining circuits (R_{15} , R_{16} , R_{17} and R_{18} , R_{19} , R_{20}). These, in turn, feed through a selector switch into an audio amplifier, the remaining section of V_1 . The purpose of the selector switch is to permit choice of sideband and to permit conventional receiver operation. With reference to the circuit diagram, positions 1 and 2 of switch S_1 are the two sideband positions, and position 3 is the proper position for normal operation of the receiver.

CONSTRUCTIONAL DETAILS

The Signal Slicer is simple to build, especially if a commercial unit is used for the phase-shift networks. The entire unit is built into a standard four by five by six inch utility box. Most of the components are mounted on one of the five by six inch removable cover plates. This plate will be referred to as the "top."

Refer to the circuit diagram, Fig. 2. Note that two groups of components are shown inside dotted-line boxes. The components that are in these two boxes are those that are mounted on the utility box proper. All the other components are mounted on the top plate, including the phase-shift network assembly which has been indicated in the circuit diagram inside a dashed-line box. This box is marked "P.S. Network." Don't confuse this with the two dotted-line boxes in the diagram.

It may be seen that each of the two dotted-line boxes has connection points indicated by a circle with a large dot inside. There are ten of these points. These represent the connections that must be made when the wiring of the box is complete and the wiring of the top plate is complete, and you are assembling the two sections. The leads shown with the arrow at each of these points indicate a length of wire which is left long so that the connection may be made after assembly. The photograph of the top plate in Fig. 3 shows these ten wires clearly. The wires are longer

CIRCUIT CONSTANTS

(All resistors and capacitors $\pm 20\%$ tolerance unless specified otherwise)

C_1, C_2	100 mmf mica or ceramic (matched within 5%)	R_8, R_9	94,000 ohm (100,000 ohm $\frac{1}{2}$ watt $\pm 1\%$ precision resistor in parallel with a 1.5 megohm $\frac{1}{2}$ watt $\pm 5\%$ resistor)
C_3, C_4	100 mmf mica or ceramic (matched within 5%)	$R_{11}, R_{12}, R_{13},$ R_{14}	3,000 ohm, $\frac{1}{2}$ watt ($\pm 5\%$)
C_5, C_6	0.01 mf mica, paper or ceramic	$R_{15}, R_{17}, R_{18},$ R_{20}	220,000 ohm, $\frac{1}{2}$ watt ($\pm 10\%$)
C_7	2430 mmf (0.002 mf mica $\pm 5\%$ with 170-780 mmf trimmer in parallel)	R_{16}, R_{19}	100,000 ohm potentiometer
C_8	4860 mmf (0.0043 mf mica $\pm 5\%$ with 170-780 mmf trimmer in parallel)	R_{21}	5,600 ohm, $\frac{1}{2}$ watt ($\pm 10\%$)
C_9	1215 mmf (0.001 mf mica $\pm 5\%$ with 50-380 mmf trimmer in parallel)	R_{22}	2.2 megohm, $\frac{1}{2}$ watt
C_{10}	607.5 mmf (500 mmf mica $\pm 10\%$ with 9-180 mmf trimmer in parallel)	R_{23}	47,000 ohm, 1 watt
C_{11}, C_{14}	0.1 mf 400 volt paper	R_{24}, R_{25}	470 ohm, 1 watt
C_{12}	0.5 mf 200 volt paper	R_{26}	400 ohm, 4 watt ($\pm 10\%$) (Two 200 ohm, 2 watt resistors in series)
C_{13}, C_{25}	470 mmf mica or ceramic	R_{27}, R_{28}	47 ohm, $\frac{1}{2}$ watt
C_{15}, C_{16}	40 mf 150 volt electrolytic	R_{29}, R_{32}	10,000 ohm, $\frac{1}{2}$ watt
C_{17A}, B, C, D	20-20-20-20 mf 450 volt electrolytic	R_{30}	1,000 ohm, 1 watt ($\pm 5\%$)
C_{18}	300 mmf mica $\pm 5\%$, for 456 to 465 KC. (Use 240 mmf for 500 KC, I-F receivers)	R_{31}	1,000 ohm, $\frac{1}{2}$ watt ($\pm 10\%$)
C_{19}	50 mmf variable (Hammarlund HF-50)	R_{33}, R_{34}	1.0 megohm, $\frac{1}{2}$ watt ($\pm 10\%$)
C_{20}	0.003 mf mica $\pm 10\%$	R_{35}, R_{36}	51,000 ohm, $\frac{1}{2}$ watt (matched within 5%)
C_{21}	1000 mmf mica or ceramic	R_{37}, R_{38}	3.3 megohm, $\frac{1}{2}$ watt ($\pm 10\%$)
C_{22}	330 mmf mica $\pm 5\%$	S_1	Double pole, three position shorting type rotary switch
C_{23}	5-50 mmf mica trimmer (El Menco T-52210)	S_2	SPST Toggle Switch
C_{24}	10 mmf mica or ceramic	SR.....	Voltage doubler type selenium rectifier, rated 160 RMS volts at 100 ma (Federal 1008A)
J.....	Open circuit jack	P.....	6.3-volt pilot lamp
L_1, L_2, L_3, L_4	All made from one R-F choke (see text)	T.....	Power Transformer, 135-volt A-C RMS secondary at 75 ma, 6.3 volts at 1.5 amps (Thordarson R-22R12)
R_1	10,000 ohm, $\frac{1}{2}$ watt ($\pm 10\%$)	P.S. Net- work.....	Millen No. 75012 or home-made equivalent (see text)
R_2	680,000 ohm, $\frac{1}{2}$ watt ($\pm 10\%$)		
R_3, R_4	2,000 ohm, $\frac{1}{2}$ watt precision ($\pm 1\%$)		
R_5, R_6	7,000 ohm, $\frac{1}{2}$ watt precision ($\pm 1\%$)		
R_7, R_{10}	133,300 ohm, $\frac{1}{2}$ watt precision ($\pm 1\%$)		

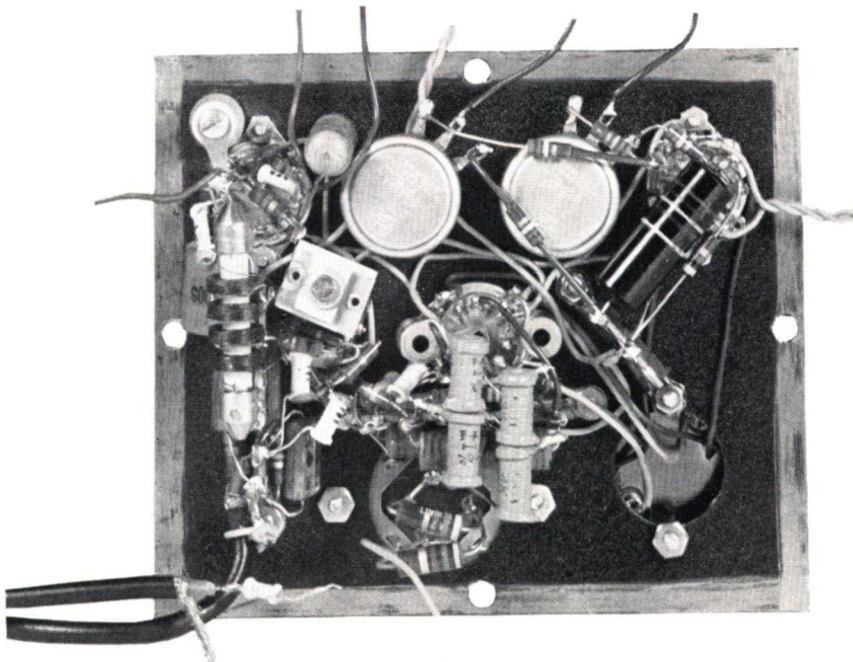

Fig. 3. Detail view of the wiring on the top panel of the Signal Slicer.

than the photograph shows. Make each one about 5 inches long, then cut them to length when assembling the adapter.

A drilling layout is shown in Figs. 6, 7 and 8 for those who wish to duplicate the original unit exactly. If another type of construction appeals to you, a reasonable duplication of the layout shown is suggested.

With reference to Fig. 4, the power transformer, the selenium rectifier, condensers C_{15} , C_{16} and resistor R_{26} are mounted on the rear apron of the utility box. This rear apron also has two grommets mounted on it to handle the a-c line and the input probe cable. On the front apron you mount the pilot light, power switch S_2 , resistors R_{27} , R_{28} , oscillator tuning control C_{18} , C_{19} , output jack, selector switch S_1 , condenser C_{14} and resistors R_{22} and R_{23} . All the wiring involved with these components can easily be completed if the two removable plates are not in place. Because of tolerances on certain components and the particular I-F of your receiver, it is well to mount C_{18} directly across C_{19} so that possible pruning operations may be done conveniently without removing the top plate.

The one inch diameter hole specified for the phase-shift network is used regardless of whether a Millen unit or a home-made unit is employed. Details of the home-made unit will be given later.

It is desirable to remove the paint from the top lip of the utility box, and from the four edges of the top plate, to ensure good electrical contact when the two parts are joined.

Coils L_1 , L_2 , L_3 and L_4 require explanation. All four coils are made by making some minor changes on a single National R-100 R-F choke. This choke has four pies, and each pie becomes a coil. To make the necessary changes, refer to Fig. 5, and proceed as follows. Examine the coil and the individual pies. You will note that one lead on each pie comes off the outside of the pie, and the other lead comes from the part of the pie nearest the ceramic support. Orient the choke in your hand until it is as shown in Fig. 5,

that is, so that the lead from the right-hand end goes to the outside of the farthest-right pie, L_1 .

Carefully loosen two turns on the outside of L_2 and then cut the wire to provide an inch or so of lead from the inside of coil L_1 . Remove the insulation and the enamel from the end of this lead. The two connections to coil L_1 are now the original pigtail and the inch or so of wire removed from the outside of coil L_2 .

Repeat this operation on coil L_3 to provide leads for coil L_2 , as well as a connecting lead from L_3 to L_1 . Continue as shown in Fig. 5 until you have L_1 in series with L_3 and L_4 , with L_2 having separate, unconnected leads. Tin the ends of all wires and solder the connection between L_1 and L_3 . Double-check to make certain that your leads are as shown in Fig. 5, that is, that the leads come from the top of the pie where so indicated and from the center of the pie, where so indicated. This is important, because this determines the direction of the winding on the form. The entire procedure probably will take less time to do than the time you have spent reading this. The inductance of each pie of the National R-100 choke is approximately 420 microhenries.

For wiring details of the top of the Signal Slicer, refer to Fig. 3. The coil assembly (L_1 through L_4) is mounted with the L_1 end fastened to a ceramic stand-off post and the other end connected to one lug of a terminal strip. The common connection of L_1 and L_3 should be made to the end lug of the terminal strip nearest V_1 , and the two connections from L_2 to the next two lugs. Make certain that the coil will clear the lip on the box as the chassis is mounted. The remainder of the wiring is quite straightforward and should present no difficulty. Note that R_5 and R_6 are actually each made up of a 3000 and a 4000 ohm resistor in series, since 7000 ohm resistors were not immediately available.

Remember to leave several inches of hookup wire at each of the ten connection points, so that the final assembly consists in cutting these wires to length and

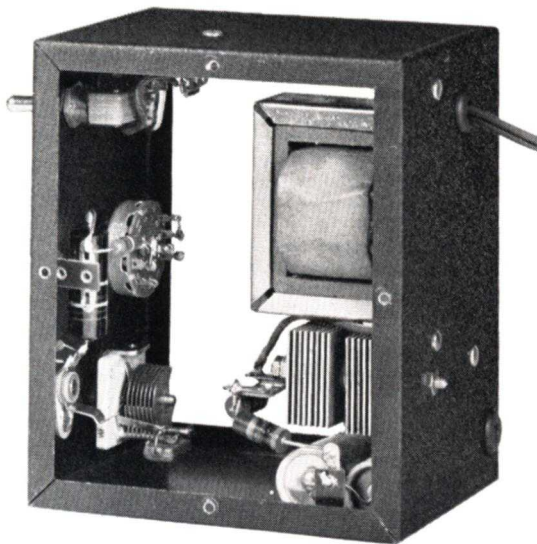

Fig. 4. Detail view of the completely wired interior of the Signal Slicer.

soldering them to the proper points on the box proper. Obviously, all wiring should be completed on the top plate before the final connections to the box are made. The probe cable should be made of approximately two feet of RG-58/U cable, and C_{24} soldered to the far end. The cable may be shorter or longer, but try to keep its length under six feet.

PHASE SHIFT NETWORKS

The Millen No. 75012 network is a complete and aligned pair of phase-shift networks. To use this unit in the Signal Slicer a slight modification is required to achieve optimum results. Each of the 100,000 ohm precision resistors (R_8 and R_9 in the circuit) should be paralleled with a 1.5 megohm five percent tolerance $\frac{1}{2}$ watt carbon resistor. To do this the can must be taken apart to permit access to the resistors. The photograph (Fig. 9) shows where these resistors have been added to the Millen unit. Make no other changes or adjustments, since these units are pre-aligned at the factory.

The change mentioned is beneficial in taking account of the effective source impedance presented by V_3 and associated circuits.

If desired, you may make your own phase-shift network unit. The home-made unit pictured in Figs. 10 and 11 is made in a Millen No. 74400 plug-in shield can. The octal base pictured is a part of this unit. The components are supported on a vertically-mounted piece of insulating material, such as bakelite, poly, etc. The size of this piece is $3\frac{5}{8}$ by $1\frac{3}{4}$ inches by $\frac{1}{8}$ inch thick. This is secured to the mounting posts by two small right-angle brackets. The suggested terminal arrangement is pictured quite clearly in Figs. 10 and 11. The fixed mica condensers are mounted on one side of the insulating material, and the adjustable trimmers and resistors on the other side. Mount, but do not solder these components in place until the phase-shift networks have been aligned.

The suggested pin connections for a home-made unit are as follows: Pin 1, ground; pins 2, 3 and 4, network "A"; and pins 6, 7 and 8, network "B."

Electrically the two networks in this can are identical to the ones used in the SSB, Jr., except for the modification noted above for the Millen unit. (For convenience, the symbol numbers indicated in Fig. 2 in this issue are the same as were used in Figs. 2 and 3A of the Vol. 5, No. 6, *Ham News* describing the SSB, Jr.)

After completing the phase-shift unit leave the can cover off until the adjustments are made and the two 1.5 megohm resistors added across R_8 and R_9 . Run a wire from pin 1 on the phase-shift unit to one of the mounting posts inside the No. 74400 can to allow grounding. To prevent inadvertent short circuits, a stiff piece of insulating material (such as waxed Kraft paper) should be placed inside the can as is usually done in commercial I-F transformers.

If a home-made phase-shift network is used, an octal socket will be required on the top plate to accommodate the Millen No. 74400 unit. The alignment of the home-made phase-shift network will be discussed later.

COMPONENT PARTS

As is true with many equipment designs, there are some component parts in the Signal Slicer that must be chosen carefully. The precision resistors specified are important if optimum results are to be obtained. Continental "Nobleloy" 1% resistors were used in the original models of the Signal Slicer (where 1% resistors are specified) although any other make of equal quality should work equally well.

Some of the other resistors are specified with tolerances of 5% or 10%. This has been done to ensure a piece of equipment which will be capable of being tuned up properly after you complete it. If you desire, use 20% tolerance resistors which you have measured to make certain that they are within the required tolerance. Certainly one or two of these values may vary as much as 20%, but if all the resistors varied this much, in the wrong direction, you might have a much harder job getting the unit to work properly.

The adjustable mica trimmers used in the phase-shift networks may be any good grade of trimmer. Those actually used are El Menco: T52910 for C_7 and C_8 ; T52510 for C_9 ; and T52310 for C_{10} .

It is important that you use a National R-100 2.5 mh. choke for L_1 , L_2 , L_3 and L_4 . Other chokes will undoubtedly work, but the National R-100 is universally available, and no attempt was made to check the suitability of other four-pie 2.5 mh. chokes.

Mica condensers should be used where mica only is specified. In the other cases the specifications call for "mica or ceramic" or "mica, ceramic or paper" condensers. In general, the ceramic condensers are smaller than either the mica or paper condensers and should therefore be used if feasible. Be certain to obtain condensers within the tolerances specified.

The selector switch, S_1 , should be of the shorting type. Loud switching transients will be produced unless this precaution is observed.

The selenium rectifier specified is capable of handling 160 volts RMS. Most small selenium rectifiers are rated for only 130 volts RMS, and these were not specified because the transformer, unloaded, supplies more than 130 volts RMS, which would damage the lower-rated rectifier.

CIRCUIT ADJUSTMENTS

With the exception of alignment of the phase-shift networks (if you build your own) very few adjustments are required in the Signal Slicer. The two

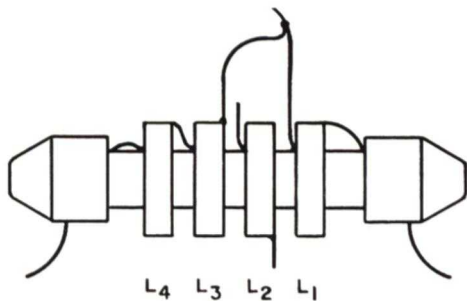

Fig. 5. Sketch of the altered R-100 choke

methods for alignment of the home-made phase-shift networks are identical to those described for the SSB, Jr. The simpler method is to use accurately measured parts (R_7 through R_{10} and C_7 through C_{10}). The more exact method involves four test frequencies which enable one to adjust each of the four capacitors, C_7 through C_{10} for perfect alignment.

The adjustment procedure using the test frequencies is as follows. First, determine that the resistors R_7 and R_8 (as well as R_{10} and R_9) bear the ratio of 133,333 to 100,000, that is, 4 to 3, as closely as can be determined. If there is any doubt about the value of the resistors, double-check their values on an accurate bridge. Next procure the two necessary instruments, which are an audio oscillator capable of providing output frequencies in the range between 300 and 2000 cycles per second, with good waveform, and an oscilloscope. The oscillator may be calibrated by the method described later. Connect the oscillator output through a step-down transformer (a conventional audio transformer run "backward" will do nicely) into a 1000 or 2000 ohm potentiometer with the arm of the potentiometer grounded. See Fig. 12.

Adjust the arm position so that equal (but opposite) voltages appear on each half of the potentiometer. A steady audio frequency signal of any convenient frequency may be used with an oscilloscope acting as a convenient voltmeter for this job. Swing the vertical deflection lead from one end of the potentiometer to the other and adjust the arm to obtain equal voltages (a true center-tap). Set up a temporary double cathode-follower circuit using a 12AT7 with 500 ohms from each cathode to ground and connect as shown in Fig. 12. (It will be convenient to provide leads M, N, and 1 and 2 with clips at the ends to facilitate checking.) The horizontal and vertical plates of the oscilloscope should be connected to the 12AT7 cathodes as shown in Fig. 12 and the scope common connection should go to the arm of the potentiometer.

Now, refer to the circuit diagram, Fig. 2, and disconnect the elements in your home-made phase-shift network as follows. Disconnect the left-hand end of

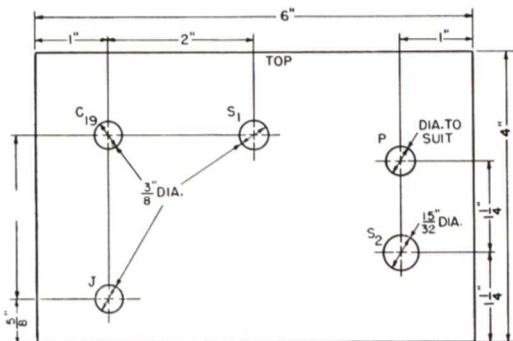

Fig. 6. Layout dimensions for the front of the Signal Slicer. The dimension on the left which is blank should be $1 \frac{7}{8}$ inches. Note also that the holes for C_{19} and S_1 are not shown in true perspective, because they are actually closer to the bottom of the panel than the hole for the panel light. The dimensions shown are correct.

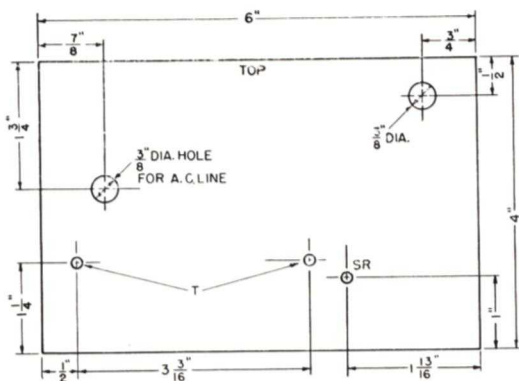

Fig. 7. Layout dimensions for the rear of the Signal Slicer.

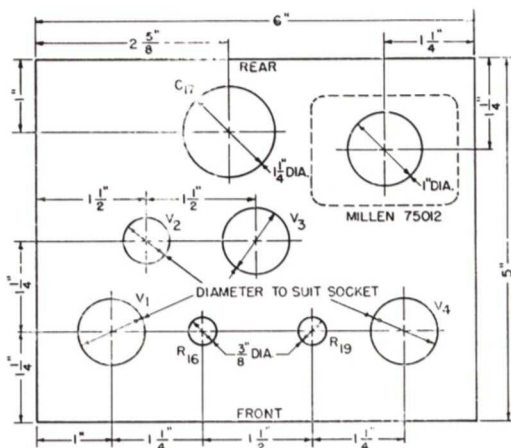

Fig. 8. Layout dimensions for the top panel of the Signal Slicer.

R₇ from C₇. Disconnect the left-hand end of R₁₀ from C₁₀. You are now ready to proceed with the alignment.

Connect lead M (Fig. 12) to the left-hand end of R₇ and connect lead N to the left-hand connection of C₇. Connect leads 1 and 2 (Fig. 12) to terminal M. Adjust the horizontal and vertical gains on the oscilloscope to produce a line about 1½ inches long slanted at 45 degrees when the oscillator is set to a frequency of 490 CPS. If the oscilloscope has negligible internal phase shift the display will be a straight line instead of a narrow slanting ellipse. If the latter display appears it is necessary to correct the oscilloscope phase shift externally by using an adjustable series resistance (a 50,000 ohm potentiometer) mounted at either the vertical or horizontal input terminal, depending on what correction is necessary.

At any rate, the objective here is to get a straight line at 490 CPS. In some cases a series capacitor may be needed to provide the necessary correction. Try values from 0.05 to 0.0005 mf. Now shift lead 1 from the left-hand end of R₇ to the junction of R₇ and C₇. Adjust the trimmer of C₇ to obtain a circle on the oscilloscope. It will be noted that as this adjustment is made the display will shift from an ellipse "leaning" to one side through a circle or ellipse (with axes parallel to the deflection axes) to an ellipse which leans the other way. If desired or necessary, the appropriate gain control on the oscilloscope may be changed so that a circle instead of a "right" ellipse is obtained at the point of correct adjustment. After changing the gain control on the oscilloscope, check (and correct, if necessary) the phase shift in the oscilloscope by moving lead 1 back to the left-hand end of R₇, and then repeat the setting of C₇ with lead 1 back again on the junction of R₇ and C₇.

In general, always make certain that the oscilloscope is used in a phase-corrected manner. As a double-check (if the deflection plates in the 'scope are skewed, for instance) connect lead 2 to the left-hand end of C₇. If the circle changes to a slanting ellipse, readjust C₇ to produce an ellipse half-way between the ellipse (obtained by switching lead 2)

and a circle. Changing lead 2 from the left-hand end of C₇ to the left-hand end of R₇ and back again should give identical skew to the display when C₇ is set correctly. Failure to get symmetrical ellipses (egg-shaped, or other display) is due to distortion, either in the oscilloscope, the oscillator, the transformer, or the cathode follower. Conduct the test at as low a signal level as possible to avoid distortion.

Next, connect lead M to the left-hand end of R₁₀ and lead N to the left-hand end of C₁₀. Connect leads 1 and 2 to lead M, set the oscillator frequency to 1960 CPS, correct 'scope phase-shift as before, and move lead 1 to the junction of C₁₀ and R₁₀. Adjust C₁₀ for a circle as was done for C₇, using the precautions outlined for that case.

Now connect lead M to the left-hand end of R₉ and lead N to the right-hand end of C₉. Connect leads 1 and 2 to lead M, set the oscillator frequency to 1307 CPS, correct 'scope phase-shift as before, and move lead 1 to the junction of R₉ and C₉. Adjust C₉ to obtain a circle on the oscilloscope, as before.

Repeat the above procedure for the remaining R-C pair, R₈ and C₈. Use an oscillator frequency of 326.7 CPS. This completes the alignment of the phase-shift network. None of the preceding alignment instructions need be carried out if a Millen No. 75012 network is used.

Re-connect the phase-shift units, connecting the left-hand end of R₇ to C₇, and the left-hand end of R₁₀ to C₁₀. Connect the phase-shift units to the base pins of the plug-in can assembly and solder all connections. Shunt R₈ and R₉ with the 1.5 megohm resistors previously mentioned, then place the cover on the plug-in assembly. Remember to use some insulating material inside the can as mentioned previously.

AUDIO OSCILLATOR CALIBRATION

It will be noted that the frequency ratios are such that the 12th harmonic of 326.7 CPS, the 8th harmonic of 490 CPS and the 3rd harmonic of 1306.7

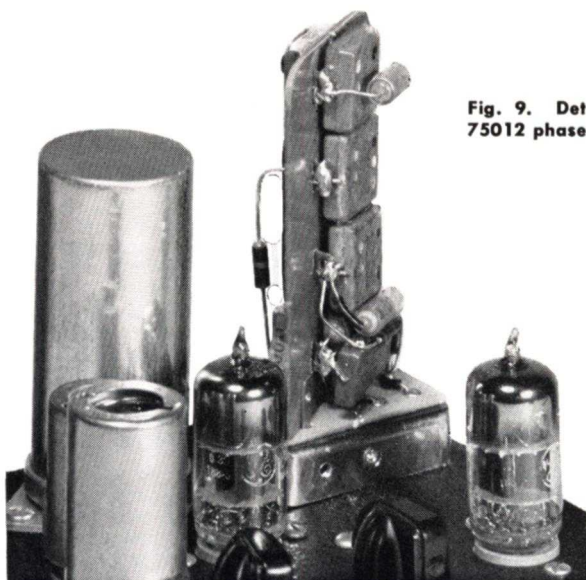

Fig. 9. Detail view of the Millen No. 75012 phase-shift network.

CPS are all the same as the 2nd harmonic of 1960 CPS, namely, 3920 CPS. Thus, if a stable source of 3920 CPS frequency (such as a thoroughly warm audio oscillator) be used as a reference, the frequency of the test oscillator can be set very closely to one-half, one-third, etc., of this reference frequency if both oscillators feed an oscilloscope and the resulting Lissajous figures observed.

Use of a calibrating frequency in this manner assures that the frequency ratios used are correct, even though the exact frequencies used are unknown. The frequency ratios (just as the resistance ratio previously mentioned) are far more important than the actual values of frequency (or resistance) used.

CONNECTION TO RECEIVER

After completion of the wiring and a thorough wire-check you are ready to connect the adapter to the receiver. The connection from the "hot" side of the I-F transformer to the diode plates of the detector in the receiver should be removed, and the audio connection from the detector output to the A-F gain control should be opened. The shield of the adapter cable connects to ground on the receiver, and the 10 mmf capacitor connects to the hot side of the I-F transformer, in place of the diode plates.

The output of the adapter may be used directly on headphones, or an audio lead may be plugged into the output jack of the adapter (J) and wired into the audio input of the receiver. It can be seen that the Signal Slicer essentially replaces the detector normally used in the receiver. The AVC action in most receivers so altered will now be completely out of service, as will the S-meter. (Even if the AVC is not disabled, it should not be used when using the Signal Slicer.) The RF gain control will be the main gain control of the receiver. It is difficult to give specific information for connection of the Signal Slicer to all receivers, but the above information covers most cases that will be encountered.

Some receivers have an accessory plug in the rear. Find out whether the amount of power available from this plug is ample to supply the requirements of the Signal Slicer if you contemplate borrowing the power from the receiver instead of using a built-in power supply. The heater power required is 6.3 volts at 1.2 amperes and the high voltage required is 250 to 300 volts at approximately 25 ma. It is recommended that the filter section consisting of R_{24} , R_{25} and C_{17} be retained regardless of the power supply used.

FINAL ADJUSTMENTS

Turn on both the receiver and the Signal Slicer and allow a few minutes warm-up time. The R-F gain control of the receiver should be all the way to zero and the AVC switch set for "manual" or "RF." Plug headphones into the output jack (J) on the adapter, set the selector switch to normal (position 3), advance the R-F gain until the receiver sounds "live" and tune in an AM station, governing the output with the R-F gain control. Keep this output reasonably low. Be certain to *tune* the receiver to maximum output (remember, there is no AVC and no S-meter) with minimum I-F bandwidth, if the receiver is so equipped, but do not use the crystal filter at this time. Trim the secondary of the last I-F transformer to compensate for any shift of its tuning caused by connection of the Signal Slicer input circuit. Set the two balance potentiometers (R_{16} and R_{19}) about midway and turn the selector switch on the adapter to one of the sideband positions (position 1 or 2). This actuates the oscillator in the Signal Slicer.

Tune the oscillator (with C_{19}) to zero beat with the received carrier, at which point good, clean audio reproduction should result. If the oscillator will not tune to zero beat within the range of C_{19} , replace C_{18} with different values of capacitance until zero beat can be obtained with C_{19} near mid-range.

Now, detune the *receiver* until a beat note of about 1000 CPS is heard. Try detuning first on one side, and then on the other, leaving the receiver set for the *weaker* heterodyne. Adjust the appropriate resistor (R_{16} or R_{19} , depending on the selector switch position) for a *minimum* heterodyne. Then detune the receiver to the other side of the signal, switch to the other sideband with the selector switch, and adjust the other potentiometer for a minimum heterodyne. Quite possibly neither minimum will be a complete null at this time.

Adjust C_{23} for a further reduction in heterodyne strength (readjusting the oscillator frequency with C_{19} if necessary to maintain the same beat note). Adjust the potentiometer (R_{16} or R_{19}) for still further reduction of heterodyne strength, switch to the other sideband position, retune the *receiver* for a beat note of 1000 CPS on the other side of zero beat, and adjust the other potentiometer for a minimum heterodyne signal strength. You will find that the sharpness of the minimum becomes more pronounced each time the above process is repeated until C_{23} is set at the optimum point, just as in balancing a bridge.

Throughout the above adjustment procedure it is assumed that the Signal Slicer is in working order other than for the correct settings of the few adjustments just covered. If no signal is heard at any time, or if excessive hum or other evidence of trouble appears, a thorough trouble-shooting routine is indicated.

OPERATING INFORMATION

After a short time of familiarization the user of the Signal Slicer will find that he listens almost exclusively to one or the other of the sideband positions, rarely ever going back to normal reception. In most cases reception of AM, NBFM, CW and Single-Sideband signals will be greatly improved over conventional reception methods. If interference appears when listening to one sideband of an AM or NBFM signal, simply switch to the other sideband to dodge the problem. Do not try to "tune out" interference—switch it out instead. Sometimes, even then, the going is rough, as we all know. That's the time to switch to normal reception to find out how rough it really is. At least, with the Signal Slicer, you can always get rid of the interference that appears on any one side of the received signal.

Since extremely close tuning (within 100 CPS) is generally necessary, the receiver should have a good bandspread arrangement, and should, therefore, have excellent stability. Some signals will be found where the Signal Slicer is of no advantage whatever because the signals themselves are characterized by excessive drift, syllabic instability, or other obvious faults. Then too, some receivers exhibit faults quite similar to those mentioned for transmitters. Do not expect the Signal Slicer to cure either a "rotten" signal or a receiver that, for instance, makes *all* CW signals sound rough, or one that has excessive drift.

In general, operate the receiver with the lowest R-F gain control setting that gives comfortable audio output. An overloaded receiver is just as bad as an overloaded transmitter (perhaps worse) as far as the listener is concerned. The crystal filter in the receiver may be used in the conventional manner.

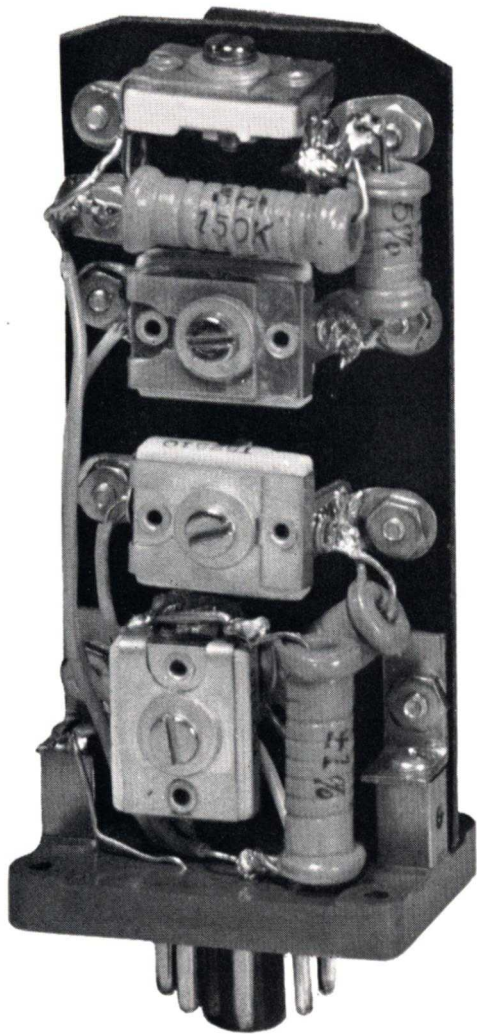

Fig. 10. Internal view of the front of the home-made phase-shift network.

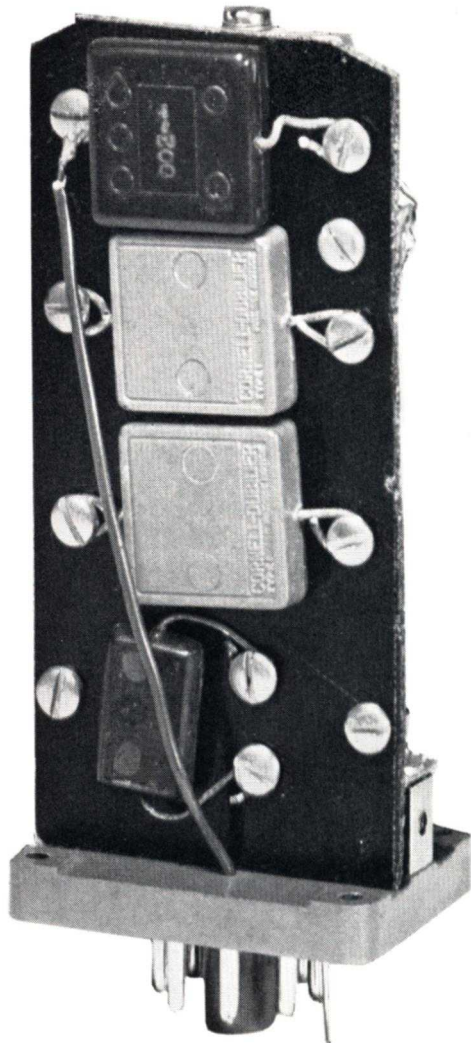

Fig. 11. Internal view of the rear of the home-made phase-shift network.

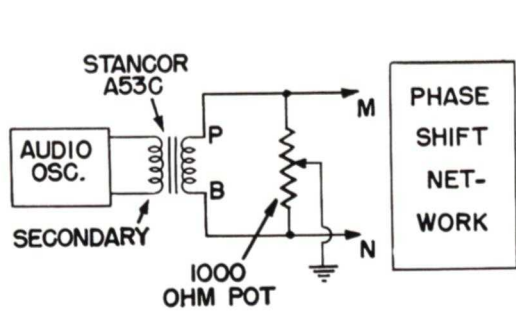
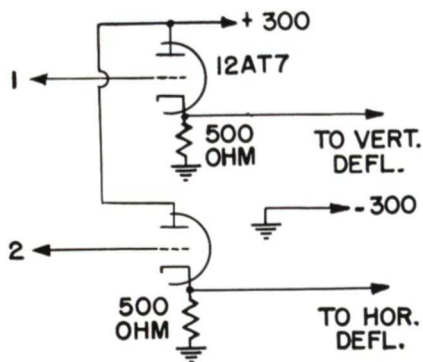

Fig. 12. Temporary layout required to test phase-shift networks.



Notes on the Application of the Signal Slicer

I asked the designer of the Signal Slicer, W2KUJ, to make some general comments on the characteristics and use of this new SSB unit. The following remarks are his.

—*Lighthouse Larry*

Many hams who do not operate single-sideband 'phone stations feel that a single-sideband receiving system would be of no use to them. The fact is, it is probably more useful to them for receiving CW and AM 'phone signals than it would be to a SSB enthusiast for receiving SSB signals (although the SSB ham has long since learned the usefulness of such a receiving system).

In other words, if the Signal Slicer is good for SSB 'phone reception (I can assure you it is—Ed.) it should be dandy for CW, especially traffic nets, where one or more of the stations may slip away from the crystal filter and turn up missing on a few receivers.

Going a bit further in our thinking, an AM 'phone station is just like two single-sideband stations (at the same carrier frequency) that just happen to be transmitting identical signals on opposite sidebands. Therefore, one isn't missing anything if he doesn't listen to one of the signals. The Signal Slicer allows the receiving operator to select which one of the signals he doesn't want to hear. This sounds ridiculous on the face of it, until you consider that one of these "stations" is liable to be severely heterodyned, which is a polite way of saying that the QRM on that station is terrible.

If this QRM situation exists, the operator can flip a switch and hear the same transmission on the other side, where no heterodyne exists. Obviously, the operator isn't choosy about which side he listens to, as long as he can hear the same thing on either side. This is what is known as broad-nosed selectivity with extremely steep side-slope—a rather valuable asset in many situations.

The Signal Slicer, however, goes one step beyond providing just usable selectivity as such. The demodulator is made as nearly distortionless as one could pray for, because *all* incoming signals are smaller by a factor of some 200 or better than the carrier signal that is supplied by the built-in oscillator to the detector system. This is exalted carrier operation with a vengeance, but it certainly pays handsome dividends.

One dividend is the elimination of "mushing up" when receiving a fading signal; another is in reduction of the apparent volume range of a fading signal—so much so that loss of the AVC function in a

receiver using the Signal Slicer is actually a distinct gain. But, don't take my word for it—try it yourself.

A word about the demodulator circuit is in order at this point. You might be tempted (even as I was) to use germanium diodes in place of the 6AL5 diode tube, and thus end up with a three-tube Signal Slicer. If you like to listen to noise this simplification is recommended. However, if you want a good SSB receiver adapter, use the 6AL5 or some other thermionic diode tube. My physicist friends tell me that the effective noise resistance of germanium diodes is extremely high, compared to a tube like the 6AL5, when you operate at low frequencies with only a few microamperes of d-c flowing in the circuit. My friends were correct. The tube is as quiet as a tomb lined with rock wool compared to the germanium diodes. For this particular application, a tube works out better than germanium diodes.

Somebody (perhaps it was Aesop or Confucius, I don't recall) said that the merit of a radio receiver was not in what it would receive, but in what it *wouldn't* receive. Of course, receivers have on-off switches, but what I mean is, doesn't your present receiver receive too much?

I am certain that you will agree that many, many times, on a single frequency, you have received more signals than you knew what to do with.

So, if these ancient philosophers were right, the Signal Slicer is a merit improver, although it's not perfect. The frequency range over which you can expect to get at least 40 db. signal rejection is controlled by the phase-shift network, and its range is 225 to 2750 cycles per second. This, of course, more than covers the region of most acute hearing, but what about the audio frequency range outside these limits?

At 4000 cycles the signal rejection due to the phase-shift network is between 36 and 37 db., and at 8000 cycles it is about 30 db. The audio amplifier in the Signal Slicer is deliberately designed to have a response which is down 3 db. at 4000 cycles, 9 db. down at 8000 cycles, etc. (This is at a rate of about 6 db. for each octave.) Thus, at the slight sacrifice of high fidelity it is fair to say that the signal rejection is about 40 db. all the way along, because the audio response has been tailored in an identical way on the low-frequency end of the spectrum.

Add to all of this the I-F selectivity curve of your receiver and you may begin to see why we think the Signal Slicer is really about as good as anyone might want when you consider the practical aspects of reception.—W2KUJ

SWEEPING *the* SPECTRUM



Every amateur reading the current amateur radio magazines must be struck by the fact that a large number of manufacturers are advertising that they need engineers. Just why there is a shortage of engineers at this time is a long story, and one that I'm not going to discuss here; however, I thought that you, as amateurs, might be interested in the future outlook for engineers. Many of you are about to enter college. Many of you may be engineers that are not following your profession at this time.

Is it a good idea to enter upon a course of engineering study at this time—will it be profitable for you engineers to return to engineering work? The answer is a resounding yes. To prove this you only need examine a few figures. In 1950 approximately 51,000 engineers were graduated with B.S. degrees. In 1951, 32,500 graduates are expected in the same category. For 1952, 21,500; for 1953, 17,000; and for 1954 only 12,400 graduates are predicted!

Experts in the field claim that there is need for at least 30,000 engineering graduates per year. The deficiency we will face in 1952, 1953 and 1954 is staggering. I am giving these facts to encourage all of you who have engineering qualifications to think about taking an engineering course, and to convince those of you that are engineers that you should use your engineering ability where it will do you, and our country, the most good.

The figures quoted above for predicted graduates in engineering came from an editorial written by Mr. E. S. Lee, editor of *General Electric Review*, which appeared in the April, 1951 issue of that magazine. Or did you know that General Electric publishes a regular monthly magazine? I have tried, in these columns, to give you a better idea of our company, but perhaps I have never mentioned the *Review*.

This magazine has been serving electrical industry for a good many years. In fact, it will shortly celebrate its fiftieth birthday. It is edited for engineering men, and contains general-interest articles as well as articles dealing with specific design and application problems of current interest.

If you have been searching about for another good magazine to add to your present technical library, you might consider subscribing to the *General Electric Review*. You would be in good company, as many of

the top engineers in the country are subscribers. The rate, incidentally, is \$4.00 per year or \$6.50 for two years.

Fellows, believe it or not, the first run of the G-E *Ham News* bound volume was a complete success. So much so, in fact, that we have none left. We are thinking of making more available, if there is sufficient demand, but the boss wants me to tell him how many more to prepare. It would help a lot if I could get an expression of opinion from my readers. So, again, I ask your help. If you would like to get a bound volume of the G-E *Ham News*, drop me a postcard, and I'll see that one of the new batch is reserved for you.

Here are the details on the book, just as a reminder. It is a cloth-bound book containing 214 pages. Every issue of the G-E *Ham News*, from Vol. 1 No. 1 through Vol. 5 No. 6, is included. In other words, all issues from the very first, up to the November-December, 1950 issue. The price is \$2.00 postpaid. To reserve a copy send your postcard to: Lighthouse Larry, Bldg. 267, General Electric Company, Schenectady 5, New York.

I hope that all of you are familiar with the Civil Defense organization in your community. Even if some of us are unable to devote any time or equipment to our local organization, we should be acquainted with the overall plan so that we can act as operators in time of actual emergency. Most organizations are faced with an operator shortage. This becomes apparent when you consider that each control point, in time of actual trouble, must be manned 24 hours a day, for perhaps four or five days. One transmitter in one control point may therefore require the services of at least three operators, each on 8 hour shifts. Multiply by three the number of transmitters, including mobiles, that you have in your organization, and you will see just how many operators really are needed. One way or another, deal yourself in on civil defense.

—Lighthouse Larry

GERMANIUM DIODES

CONDENSED SPECIFICATIONS

G-E Type	Forward Resistance (Ohms)	Back Resistance (Ohms)	Inverse Voltage (Volts)
1N48	250	60,000	85
1N51	400	30,000	50
1N52	250	333,000	85
1N63	250	1 meg.	125
1N64	Tested for efficiency in detector circuit.		
1N65	400	250,000	85
1N69	200	59,000	75
1N70	333	122,000	125
1N72	Tested for efficiency at 500 mc.		
1N73	Balanced quad.		
1N74	Balanced quad.		
1N75	400	1 meg.	125

Note: For detailed, guaranteed specifications see bulletins X57-04-59 and X57-015.

INTERCHANGEABILITY CHART

Competitive Type	Replace with G-E Type	Competitive Type	Replace with G-E Type
1N34	1N48	1N57	1N52
1N38	1N52	1N58	1N63
1N40	1N73	1N60	1N64
1N41	1N73	CK705	1N48
1N42	1N73	CK706	1N64
1N43	1N69	CK707	1N52
1N47	1N70	CK708	1N63
1N54	1N65	CK710	1N72



Ham News

Available **FREE** from
G-E Electronic Tube Distributors

Printed in U.S.A.

A Bi-monthly Publication

TUBE DIVISIONS, ELECTRONICS DEPARTMENT

GENERAL ELECTRIC

SCHENECTADY 5, N. Y.

(In Canada, Canadian General Electric Company, Ltd., Toronto, Ont.)

GEO. H. FLOYD, W2RYT—EDITOR

FROM:

Electronics Department
GENERAL ELECTRIC
Company
Schenectady 5, N. Y.

Sec. 34.66 P. L. & R.
U. S. POSTAGE
PAID
Schenectady, N. Y.
Permit No. 148

If You Didn't Get This From My Site,
Then It Was Stolen From...
www.SteamPoweredRadio.Com

POSTMASTER: If addressee has moved and new address is known, notify sender on Form 3547, postage for which is guaranteed. When Form 3547 is sent abandon this mailing. Return only if no correct address is available.