

TECHNICAL
MANUAL

MS-15
EXCITER

VOL. 11

8
8
8

1
7
4
2

0
0
1

thru

0
0
9

TECHNICAL MANUAL



If You Didn't Get This From My Site,
Then It Was Stolen From...

www.SteamPoweredRadio.Com

MONO MODULE

TECHNICAL MANUAL

MONO MODULE

994 7988 001



HARRIS CORPORATION

Broadcast Products Division

T.M. No. 888 1742 002

Printed: October 1977
Revision A: August 1978
Revision B: April 1980
Revision E: March 1981
Revision F: June 1981

WARNING

THE CURRENTS AND VOLTAGES IN THIS EQUIPMENT ARE DANGEROUS. PERSONNEL MUST AT ALL TIMES OBSERVE SAFETY REGULATIONS.

This manual is intended as a general guide for trained and qualified personnel who are aware of the dangers inherent in handling potentially hazardous electrical/electronic circuits. It is not intended to contain a complete statement of all safety precautions which should be observed by personnel in using this or other electronic equipment.

The installation, operation, maintenance and service of this equipment involves risks both to personnel and equipment, and must be performed only by qualified personnel exercising due care. HARRIS CORPORATION shall not be responsible for injury or damage resulting from improper procedures or from the use of improperly trained or inexperienced personnel performing such tasks.

During installation and operation of this equipment, local building codes and fire protection standards must be observed. The following National Fire Protection Association (NFPA) standards are recommended as references:

- Automatic Fire Detectors, No. 72E
- Installation, Maintenance, and Use of Portable Fire Extinguishers, No. 10
- Halogenated Fire Extinguishing Agent Systems, No. 12A

WARNING

ALWAYS DISCONNECT POWER BEFORE OPENING COVERS, DOORS, ENCLOSURES, GATES, PANELS OR SHIELDS. ALWAYS USE GROUNDING STICKS AND SHORT OUT HIGH VOLTAGE POINTS BEFORE SERVICING. NEVER MAKE INTERNAL ADJUSTMENTS, PERFORM MAINTENANCE OR SERVICE WHEN ALONE OR WHEN FATIGUED.

Do not remove, short-circuit or tamper with interlock switches on access covers, doors, enclosures, gates, panels or shields. Keep away from live circuits, know your equipment and don't take chances.

WARNING

IN CASE OF EMERGENCY ENSURE THAT POWER HAS BEEN DISCONNECTED.

Treatment of Electrical Shock

1. If victim is not responsive follow the A-B-Cs of basic life support.

PLACE VICTIM FLAT ON HIS BACK ON A HARD SURFACE

A AIRWAY

IF UNCONSCIOUS,
OPEN AIRWAY

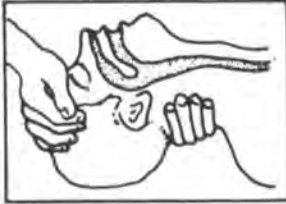

LIFT UP NECK
PUSH FOREHEAD BACK
CLEAR OUT MOUTH IF NECESSARY
OBSERVE FOR BREATHING

B BREATHING

IF NOT BREATHING,
BEGIN ARTIFICIAL
BREATHING



TILT HEAD
PINCH NOSTRILS
MAKE AIRTIGHT SEAL

4 QUICK FULL BREATHS

REMEMBER MOUTH TO MOUTH RESUSCITATION
MUST BE COMMENCED AS SOON AS POSSIBLE

CHECK CAROTID PULSE



IF PULSE ABSENT,
BEGIN ARTIFICIAL
CIRCULATION

C CIRCULATION

DEPRESS STERNUM 1 1/2" TO 2"



APPROX. { ONE RESCUER
15 COMPRESSIONS
80 SEC. { 2 QUICK BREATHS

APPROX. { TWO RESCUERS
5 COMPRESSIONS
60 SEC. { 1 BREATH



NOTE: DO NOT INTERRUPT RHYTHM OF COMPRESSIONS
WHEN SECOND PERSON IS GIVING BREATH

Call for medical assistance as soon as possible.

2. If victim is responsive.
 - a. keep them warm
 - b. keep them as quiet as possible
 - c. loosen their clothing
(a reclining position is recommended)

FIRST-AID

Personnel engaged in the installation, operation, maintenance or servicing of this equipment are urged to become familiar with first-aid theory and practices. The following information is not intended to be complete first-aid procedures, it is brief and is only to be used as a reference. It is the duty of all personnel using the equipment to be prepared to give adequate Emergency First Aid and thereby prevent avoidable loss of life.

Treatment of Electrical Burns

1. Extensive burned and broken skin
 - a. Cover area with clean sheet or cloth. (Cleanest available cloth article.)
 - b. Do not break blisters, remove tissue, remove adhered particles of clothing, or apply any salve or ointment.
 - c. Treat victim for shock as required.
 - d. Arrange transportation to a hospital as quickly as possible.
 - e. If arms or legs are affected keep them elevated.

NOTE

If medical help will not be available within an hour and the victim is conscious and not vomiting, give him a weak solution of salt and soda: 1 level teaspoonful of salt and 1/2 level teaspoonful of baking soda to each quart of water (neither hot or cold). Allow victim to sip slowly about 4 ounces (a half of glass) over a period of 15 minutes. Discontinue fluid if vomiting occurs. (Do not give alcohol.)

2. Less severe burns - (1st & 2nd degree)
 - a. Apply cool (not ice cold) compresses using the cleanest available cloth article.
 - b. Do not break blisters, remove tissue, remove adhered particles of clothing, or apply salve or ointment.
 - c. Apply clean dry dressing if necessary.
 - d. Treat victim for shock as required.
 - e. Arrange transportation to a hospital as quickly as possible.
 - f. If arms or legs are affected keep them elevated.

REFERENCE: ILLINOIS HEART ASSOCIATION

AMERICAN RED CROSS STANDARD FIRST AID AND PERSONAL SAFETY MANUAL
(SECOND EDITION)

TABLE OF CONTENTS

<u>Paragraph</u>		<u>Page</u>
SECTION I. GENERAL DESCRIPTION		
1-1.	Equipment Purpose	1
1-3.	Technical Characteristics	1
SECTION II. INSTALLATION		
2-1.	General	1
SECTION III. CONTROLS AND INDICATORS		
3-1.	General	1
SECTION IV. PRINCIPLES OF OPERATION		
4-1.	Circuit Description	5
4-2.	Input Circuit	5
4-3.	Input Protection Network	5
4-5.	Linear Phase Low-Pass Filter	5
4-6.	All-Pass Network	5
4-7.	Active Low-Pass Filter	5
4-9.	Power	6
SECTION V. MAINTENANCE		
5-1.	Corrective Maintenance	9
5-3.	Troubleshooting	9
SECTION VI. PARTS LIST		
6-1.	General	21

LIST OF TABLES

<u>Table</u>	<u>Page</u>
1-1. Technical Characteristics	2
3-1. MONO MODULE Controls and Indicators	4
5-1. MONO MODULE Fault Isolation Index	10
5-2. MONO MODULE Parts Index	12
6-2. MONO MODULE Circuit Board	23

LIST OF ILLUSTRATIONS

<u>Figure</u>	<u>Page</u>
3-1. MONO MODULE	3
4-1. MONO MODULE Block Diagram	7
5-1. MONO MODULE Parts Layout	11
5-2. MONO MODULE Waveforms	13
5-3. MONO MODULE Schematic	15
5-4. No Output (Modulation Meter Indicates Activity)	17
5-5. No Output (Modulation Meter Indicates No Activity)	18
5-6. Incorrect Low-Pass Filtering	19
5-7. Noise or Audio Distortion	20

SECTION I

GENERAL DESCRIPTION

1-1. EQUIPMENT PURPOSE

1-2. The MONO MODULE accepts a monaural audio signal input and generates a modulating signal to drive the MOD OSC module. Pre-emphasis is selectable and optional linear phase low-pass filtering protects the SCA channels from interference and provides linear overshoot control.

1-3. TECHNICAL CHARACTERISTICS

1-4. Table 1-1 lists operating characteristics and parameters of the MS-15 MONO MODULE.

SECTION II

INSTALLATION

2-1. GENERAL

2-2. Refer to 888 1742 001, MS-15 FM Exciter, Section II, Installation.

SECTION III

CONTROLS AND INDICATORS

3-1. GENERAL

3-2. Figure 3-1 shows the location of each control or indicator associated with the MS-15 MONO MODULE and table 3-1 lists the controls and indicators with a description of each.

Table 1-1. Technical Characteristics

FUNCTION	CHARACTERISTIC
<p><u>INPUTS</u></p>	
<p>POWER</p>	<p>+20 Vdc @ 0.075 amperes.</p>
	<p>-20 Vdc @ 0.080 amperes.</p>
<p>SIGNAL:</p>	
<p>AUDIO</p>	<p>+10 dBm <u>+1</u> dB for 100% modulation at 400 Hz. 600 ohm balanced resistive input impedance.</p>
<p><u>OUTPUTS</u></p>	
<p>SIGNAL:</p>	
<p>DRIVE</p>	<p>2.8V p-p for 100% modulation.</p>
<p>METERING</p>	<p>2.8V p-p for 100% modulation.</p>

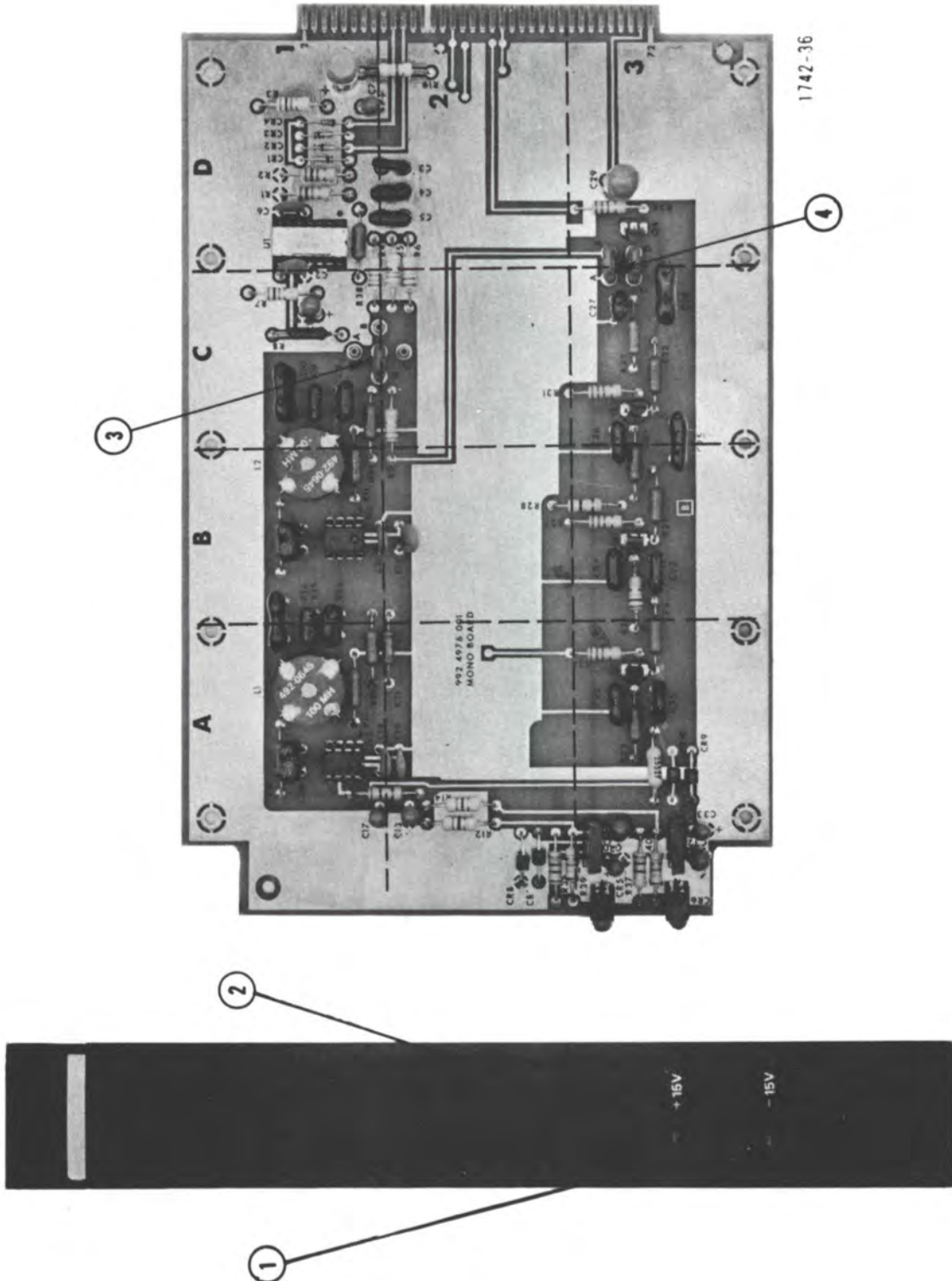

Table 3-1. MONO MODULE Controls and Indicators

REF.	CONTROL/INDICATOR	FUNCTION
1	-15V Indicator (CR6)	Illuminates to indicate the MONO MODULE -15 volt regulator is operational.
2	+15V Indicator (CR5)	Illuminates to indicate the MONO module +15 volt regulator is operational.
3	A/B/C/D Program Jumper (J1)	Selects MONO MODULE pre-emphasis A: 75 us B: 50 us C: 25 us D: flat
4	A/B/C/D Program Jumper (J2)	Enables or bypasses the linear phase low-pass filter. Enable: A to B, C to D. Bypass: A to C, B to D.

SECTION IV
PRINCIPLES OF OPERATION

4-1. CIRCUIT DESCRIPTION

4-2. INPUT CIRCUIT

4-3. INPUT PROTECTION NETWORK. Monaural audio input from the RFI filter is applied to a transformerless unity gain instrumentation amplifier (U1) through the input protection network (see figure 4-1). Damage to the pre-amplifier circuit from an excessive input signal is prevented by a configuration of four diodes connected to the +15 Vdc sources. If a signal or transient exceeding the power supply potential appears at the module input, the portion of the input which exceeds the power supply potential will be shunted by the diodes to the +15 Vdc power supply to limit the signal.

4-4. INPUT PREAMPLIFIER. The input amplifier differs from a standard operational amplifier by the inputs and the methods through which feedback is obtained. The amplifier responds only to the difference in potential between the two inputs. If the same signal is applied to both inputs simultaneously or if only one input is driven and the connection to the second input is opened, the output will be zero. The amplifier therefore behaves as a transformer with response to dc. The amplifier provides the transformer's advantages of isolation and hum rejection without the problems of limited frequency response and phase distortion. A pre-emphasis selector (J1) allows pre-emphasis selection of 75 us, 50 us, 25 us, or flat response. Amplifier gain is determined by resistor R8 and the pre-emphasis network. Pre-emphasized audio is output to the filter section and the ac metering module.

4-5. LINEAR PHASE LOW-PASS FILTER

4-6. ALL-PASS NETWORK. The first section of the filter comprises U2, U3, and associated circuit components as an all-pass network. The frequency response of this section is flat for all frequencies up to the limit of each amplifier. However, the phase characteristic is a non-linear function of frequency. The phase function of the all-pass filter is tailored to the phase of the low-pass filter. When the two phase functions are added, a linear phase results. A test point is provided at the output of the all-pass filter to check for correct operation.

4-7. ACTIVE LOW-PASS FILTER. The active low-pass filter consists of Q1, Q2, Q3, and Q4. Each stage consists of high gain Darlington transistors which are employed as unity gain emitter follower stages. In this application, an active filter is produced through the introduction of positive feedback through capacitors C35, C23, C25, and C28 to each individual stage. Each section of the filter has a different frequency response so that the product of all four sections yields a flat low-pass response which cuts off at 16.9 kHz. The first two stages have a rolled off response at approximately 3.3 kHz and 9.4 kHz respectively. The last two stages have a peaked response at 14.0 kHz and 16.6 kHz respectively.

4-8. The linear phase low-pass filter may be disabled as desired with jumper J2. The module outputs a 1.0 VRMS signal to drive the MOD OSC module.

4-9. POWER

4-10. Positive 20 Vdc enters the module on pins 31 and 32 and negative 20 Vdc enters the module on pins 41 and 42. A regulated potential to operate the module internal circuitry is developed by regulators U4 (+15 Vdc) and U5 (-15 Vdc). Light emitting diode CR5 (+15V) provides an indication of the positive supply and light emitting diode CR6 (-15V) provides an indication of the negative supply. Positive and negative fifteen volt test points are provided to assist in checking the regulator outputs.

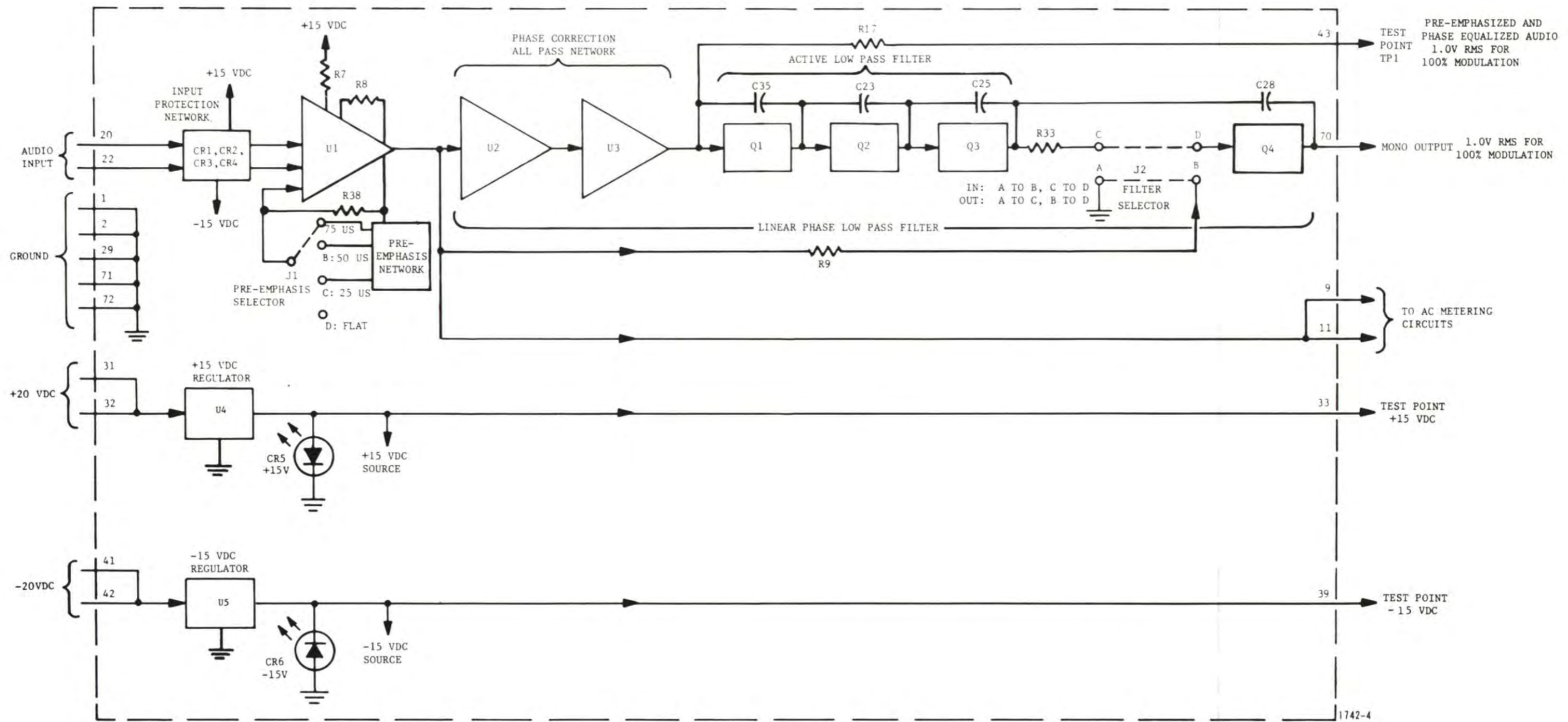

FIGURE 4-1. MONO MODULE BLOCK DIAGRAM

SECTION V
MAINTENANCE

5-1. CORRECTIVE MAINTENANCE

5-2. The MS-15 FM Exciter module maintenance philosophy consists of problem isolation to a specific area or individual component and subsequent isolation and replacement of the defective component.

5-3. TROUBLESHOOTING

5-4. In event of problems, the trouble area must first be isolated to a specific area. Most troubleshooting consists of visual checks. The MODULATION meter, MULTIMETER, fuse F1, circuit breaker CB1, and the indicators on each module should be used to determine in which area the malfunction exists. All module power supplies are equipped with LEDs which indicate the module power supply status. A single dark LED would indicate a problem associated with an individual module monolithic voltage regulator. A consistent pattern of dark LEDs however, would indicate an exciter dc distribution bus fault.

5-5. Once the trouble is isolated to a specific area, refer to the theory section of this manual for circuit discussion to aid in problem resolution. Table 5-1 lists typical trouble symptoms pertaining to the individual module operation with references to fault isolation diagrams listing probable causes and corrective actions. A corrective action given for a trouble symptom is not necessarily the only answer to a problem. It only tends to lead the repairman into the area that may be causing the trouble. An extender board (HARRIS PN 992 4989 001) is provided with the exciter to assist in troubleshooting. In event parts are required, refer to Section VI, Parts List. The following information is contained in this section as an aid to maintenance:

<u>REFERENCE</u>	<u>TITLE</u>	<u>NUMBER</u>
Figure 5-1	MONO MODULE Parts Layout	--- ---- ---
Table 5-2	MONO MODULE Parts Index	--- ---- ---
Figure 5-2	MONO MODULE Waveforms	--- ---- ---
Figure 5-3	MONO MODULE Schematic	843 1703 001

Table 5-1. MONO MODULE Fault Isolation Index

SYMPTOM	DEFECT/REFERENCE
NO OUTPUT (modulation meter indicates activity).	Figure 5-4
NO OUTPUT (modulation meter indicates no activity).	Figure 5-5
INCORRECT LOW-PASS FILTERING	Figure 5-6
NOISE OR AUDIO DISTORTION	Figure 5-7

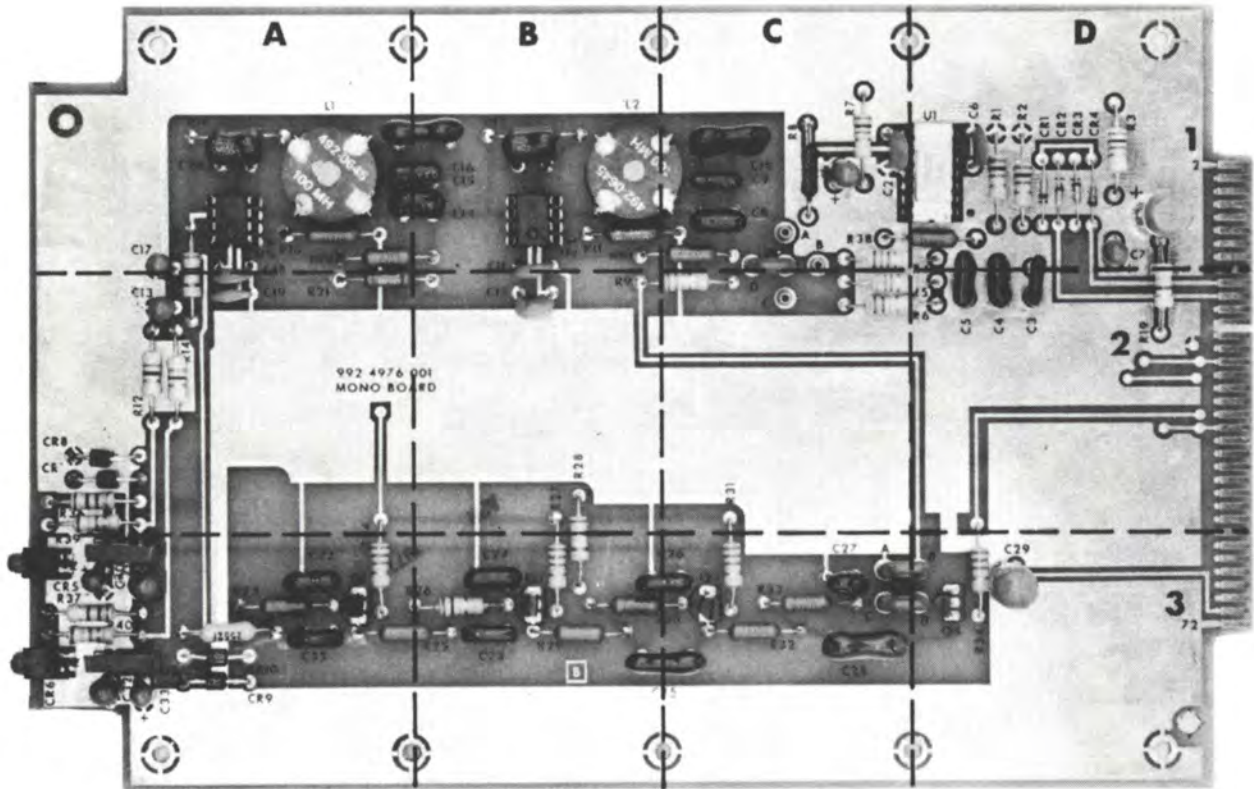

1742-37

Figure 5-1. MONO MODULE Parts Layout

Table 5-2. MONO MODULE Parts Index

SYMBOL	LOCATION	SYMBOL	LOCATION	SYMBOL	LOCATION	SYMBOL	LOCATION	SYMBOL	LOCATION
C1	C1	C29	D3	Q1	A3	R23	A3		A3
C2	C1	C30	A3	Q2	B3	R24	A3		A3
C3	D2	C31	A3	Q3	C3	R25	B3		B3
C4	D2	C32	A3	Q4	D3	R26	B3		B3
C5	D2	C33	A3			R27	B2		B2
C6	D1	C34	B1	R1	D1	R28	B2		B2
C7	D1	C35	A3	R2	D1	R29	B3		B3
C8	C1			R3	D1	R30	C3		C3
C9	C1			R4	D2	R31	C2		C2
C10	C1	CR1	D1	R5	D2	R32	C3		C3
C11	B1	CR2	D1	R6	D2	R33	C3		C3
C12	B2	CR3	D1	R7	D2	R34	D3		D3
C13	A2	CR4	D1	R8	C1	R35	--		--
C14	B1	CR5	A3	R9	C1	R36	A2		A2
C15	B1	CR6	A3	R10	B2	R37	A3		A3
C16	B1	CR7	A2	R11	B1	R38	C1		C1
C17	A1	CR8	A2	R12	B1	R39	A2		A2
C18	A1	CR9	A3	R13	A2	R40	A3		A3
C19	A2	CR10	A3	R14	B1				
C20	A1			R15	A2				
C21	--			R16	A1				
C22	A3			R17	A1				
C23	B3			R18	A1				
C24	B3	J1	C1-C2	R19	D2	U1	D1		D1
C25	C3	J2	C3-D3	R20	A3	U2	B1		B1
C26	C3	L1	A1	R21	A2	U3	A1		A1
C27	C3	L2	B1	R22	--	U4	A3		A3
C28	C3					U5	A3		A3



TEST REQUIREMENTS: A. U1 removed.
 B. 1500 Hz squarewave applied to XU1 pin 7.

1A All-pass filter output at U3 pin 6.
 1B Low-pass filter output at Q4 emitter.

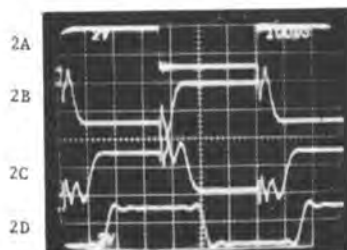

TEST REQUIREMENTS: 1500 Hz squarewave applied to exciter audio input.

2A U1 pin 7 (ringing due to RFI filter).
 2B U2 pin 6.
 2C U3 pin 6.
 2D Q4 emitter.

1742-79

Figure 5-2. MONO MODULE Waveforms

CAT 15 Mono

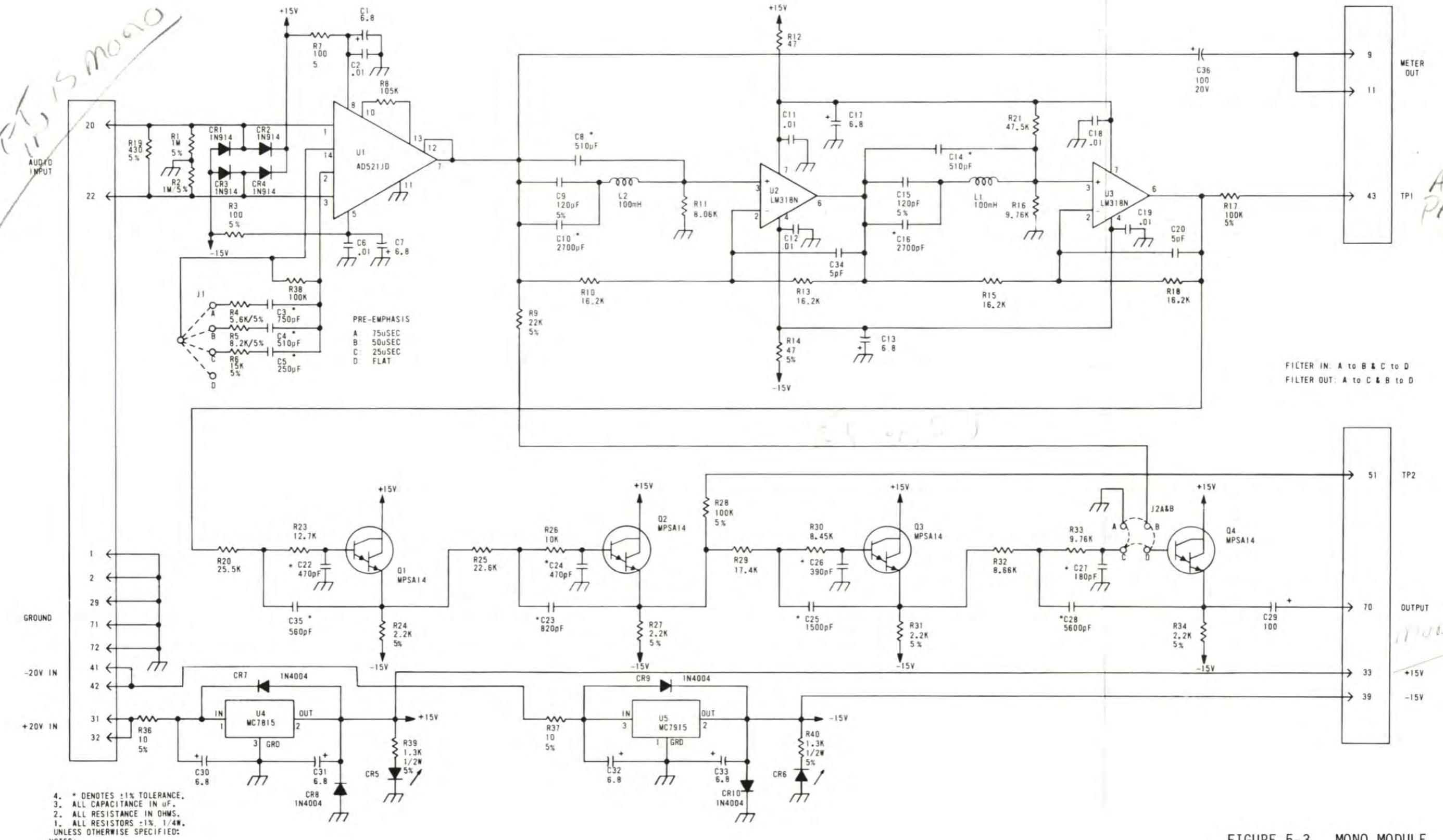

ALL PASS TEST

FILTER IN: A to B & C to D
FILTER OUT: A to C & B to D

- NOTES:
1. ALL RESISTORS ±1%, 1/4W, UNLESS OTHERWISE SPECIFIED;
 2. ALL RESISTANCE IN OHMS.
 3. ALL CAPACITANCE IN uF.
 4. * DENOTES ±1% TOLERANCE.

FIGURE 5-3. MONO MODULE SCHEMATIC 843 1703 001

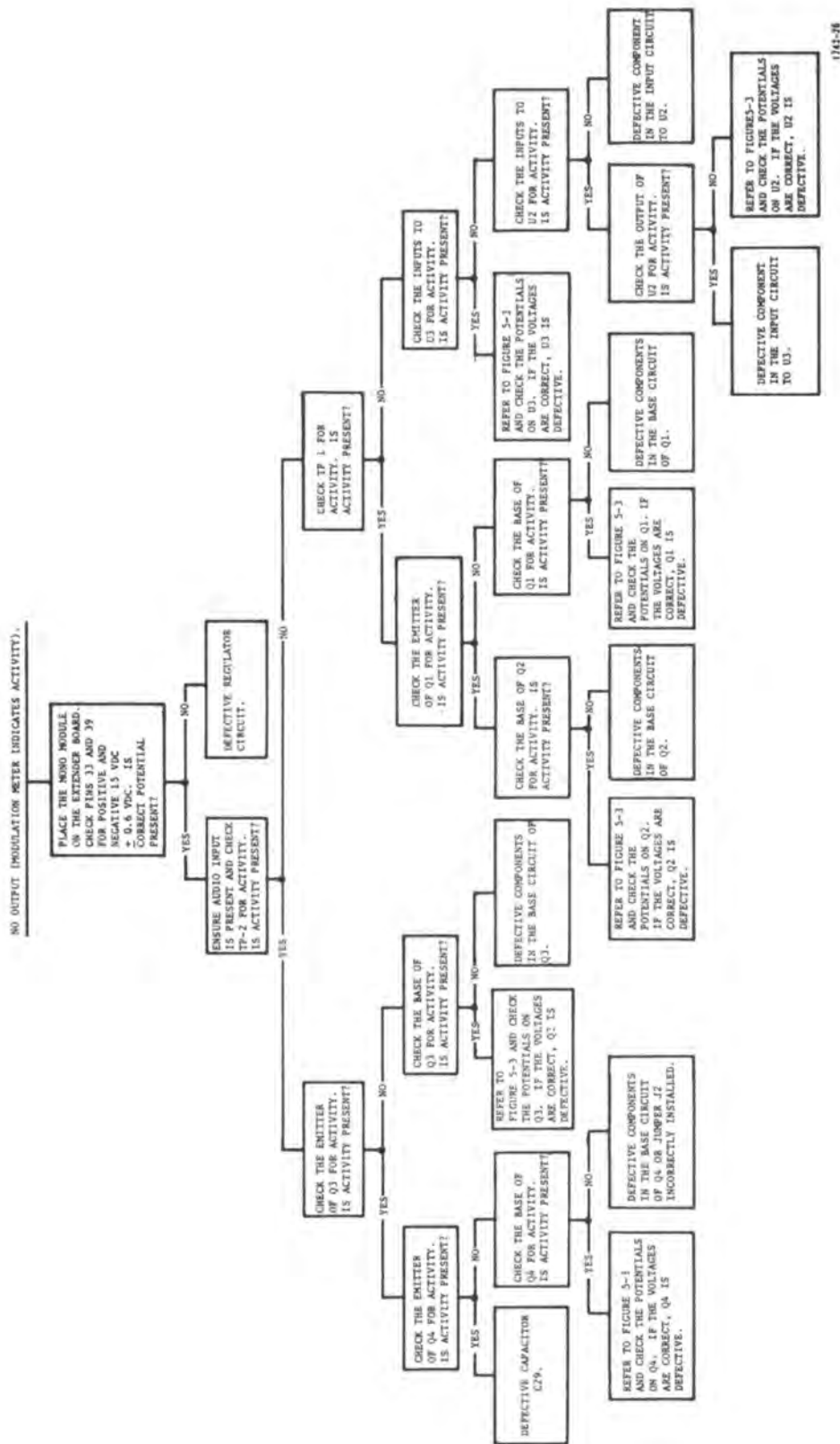
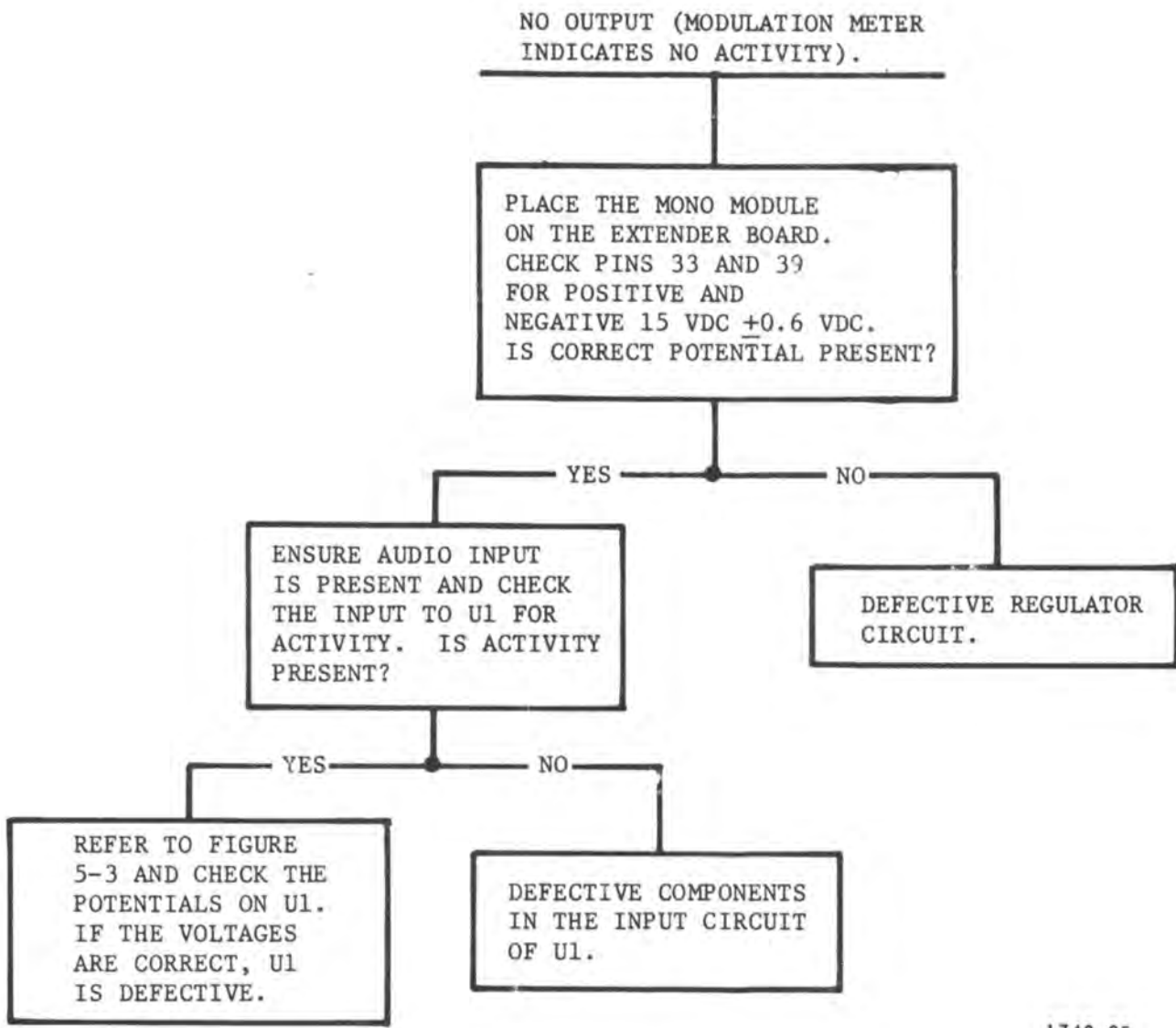
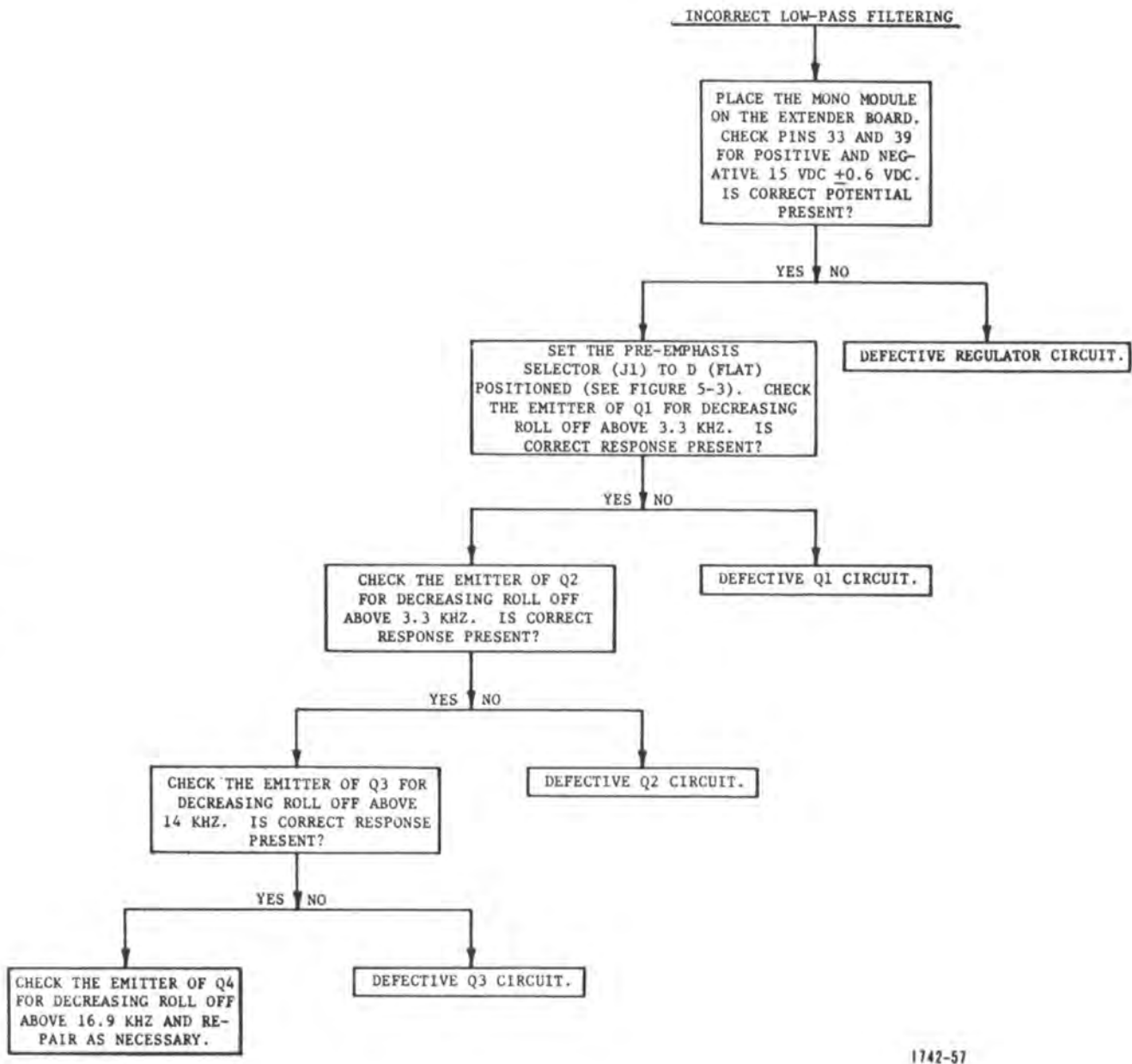

Figure 5-4. No Output (Modulation Meter Indicates Activity)



1742-25

Figure 5-5. No Output (Modulation Meter Indicates No Activity)



1742-57

Figure 5-6. Incorrect Low-Pass Filtering

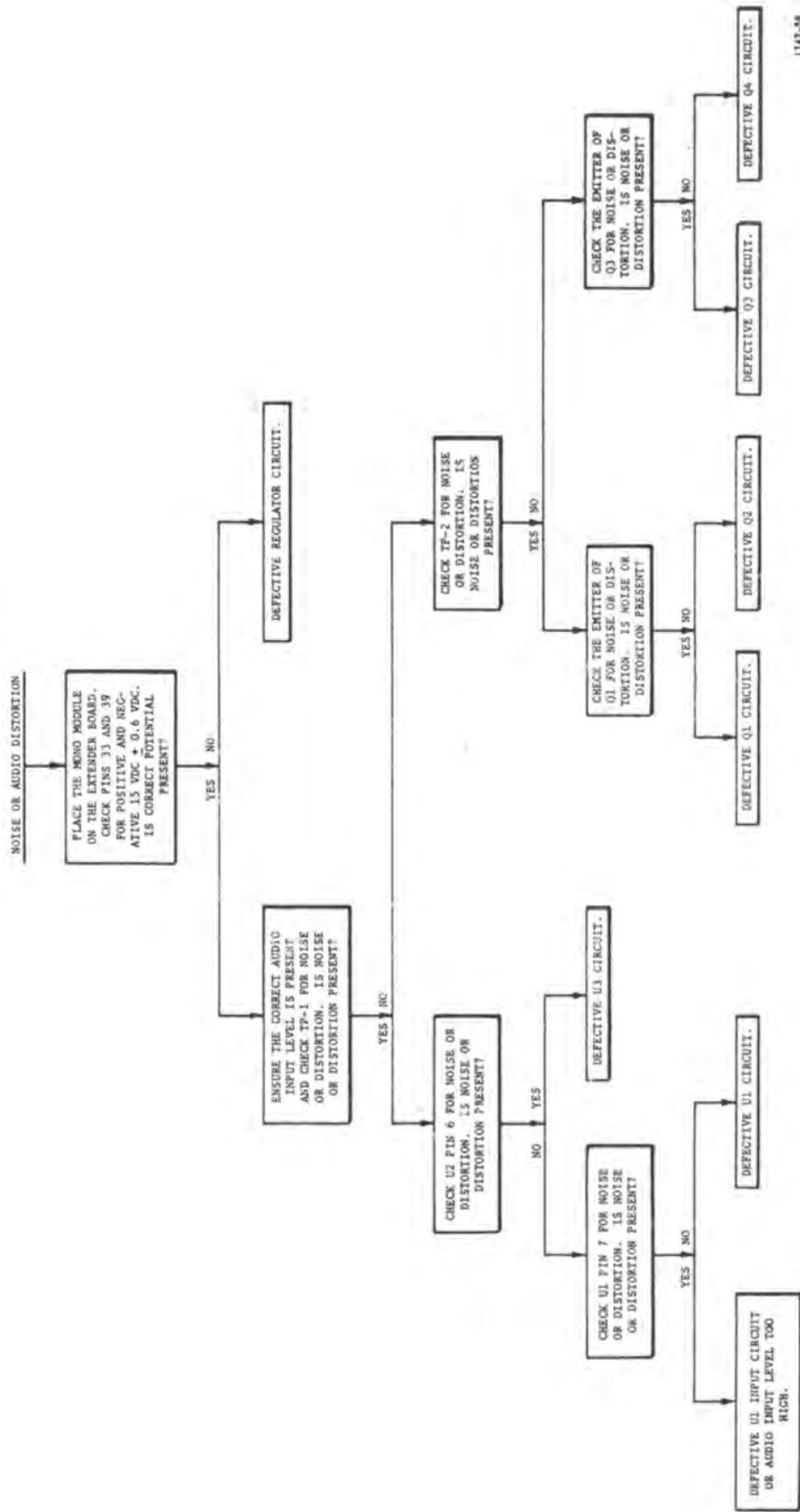

Figure 5-7. Noise or Audio Distortion

SECTION VI

PARTS LIST

6-1. GENERAL

6-2. Refer to table 6-1 for replaceable parts which are required for proper maintenance of the MS-15 MONO MODULE. Table entries are indexed by component reference designator.

Table 6-1. MONO MODULE Front Panel - 994 7988 001

REF. SYMBOL	HARRIS PART NO.	DESCRIPTION	QTY.
-----	992 4976 001	MONO MODULE Circuit Board (Refer to table 6-2)	1

Table 6-2. MONO MODULE Circuit Board - 992 4976 001

REF. SYMBOL	HARRIS PART NO.	DESCRIPTION	QTY.
C1	526 0049 000	Capacitor, 6.8 uF, 35V, 20%	1
C2	516 0375 000	Capacitor, 0.01 uF, 50V	1
C3	500 1217 000	Capacitor, 750 pF, 500V, 1%	1
C4	500 1220 000	Capacitor, 510 pF, 500V, 1%	1
C5	500 1169 000	Capacitor, 240 pF, 500V, 1%	1
C6	516 0375 000	Capacitor, 0.01 uF, 50V	1
C7	526 0049 000	Capacitor, 6.8 uF, 35V, 20%	1
C8	500 1220 000	Capacitor, 510 pF, 500V, 1%	1
C9	500 0826 000	Capacitor, 120 pF, 500V, Mica	1
C10	500 1215 000	Capacitor, 2700 pF, 500V, 1%	1
C11,C12	516 0375 000	Capacitor, 0.01 uF, 50V	2
C13	526 0049 000	Capacitor, 6.8 uF, 35V, 20%	1
C14	500 1220 000	Capacitor, 510 pF, 500V, 1%	1
C15	500 0826 000	Capacitor, 120 pF, 500V, Mica	1
C16	500 1215 000	Capacitor, 2700 pF, 500V, 1%	1
C17	526 0049 000	Capacitor, 6.8 uF, 35V, 20%	1
C18,C19	516 0375 000	Capacitor, 0.01 uF, 50V	2
C20	500 0803 000	Capacitor, 5 pF, 500V	1
C22	500 1221 000	Capacitor, 470 pF, 500V, 1%	1
C23	500 1218 000	Capacitor, 820 pF, 500V, 1%	1
C24	500 1221 000	Capacitor, 470 pF, 500V, 1%	1
C25	500 1215 000	Capacitor, 1500 pF, 500V, 1%	1

Table 6-2. MONO MODULE Circuit Board - 992 4976 001 (Continued)

REF. SYMBCL	HARRIS PART NO.	DESCRIPTION	QTY.
C26	500 1222 000	Capacitor, 390 pF, 500V, 1%	1
C27	500 1224 000	Capacitor, 180 pF, 500V, 1%	1
C28	500 1223 000	Capacitor, 5600 pF, 300V, 1%	1
C29	526 0057 000	Capacitor, 100 uF,, 20V, 20%	1
C30 thru C33	526 0049 000	Capacitor, 6.8 uF, 35V, 20%	4
C34	500 0803 000	Capacitor, 5 pF, 500V, Mica	1
C35	500 1219 000	Capacitor, 560 pF, 500V, 1%	1
C36	526 0057 000	Capacitor, 100 uF, 20V	1
CR1 thru CR4	384 0205 000	Diode, 1N914, Silicon	4
CR5,CR6	384 0661 000	LED, Green	2
CR7 thru CR10	384 0357 000	Diode, 1N4004	4
J1,J2A,J2B	610 0679 000	Plug, Shorting	2
L1,L2	492 0645 000	Inductor, 100 mH, 2%	2
Q1 thru Q4	380 0319 000	Transistor, MPS A14	4
R1,R2	540 1162 000	Resistor, 1 Megohm, 1/2W, 5%	2
R3	540 1102 000	Resistor, 100 ohm, 1/2W, 5%	1
R4	540 1183 000	Resistor, 5600 ohm, 1/2W, 5%	1
R5	540 1153 000	Resistor, 8200 ohm, 1/2W, 5%	1
R6	540 1184 000	Resistor, 15k ohm, 1/2W, 5%	1
R7	540 1102 000	Resistor, 100 ohm, 1/2W, 5%	1
R8	548 1370 000	Resistor, 105k ohm, 1/4W, 1%	1
R9	540 1160 000	Resistor, 22k ohm, 1/2W, 5%	1

Table 6-2. MONO MODULE Circuit Board - 992 4976 001 (Continued)

REF. SYMBOL	HARRIS PART NO.	DESCRIPTION	QTY.
R10	548 1364 000	Resistor, 16.2k ohm, 1/4W, 1%	1
R11	548 1396 000	Resistor, 8.06k ohm, 1/4W, 1%	1
R12	540 0017 000	Resistor, 47 ohm, 1/2W, 5%	1
R13	548 1364 000	Resistor, 16.2k ohm, 1/4W, 1%	1
R14	540 0017 000	Resistor, 47 ohm, 1/2W, 5%	1
R15	548 1364 000	Resistor, 16.2k ohm, 1/4W, 1%	1
R16	548 1438 000	Resistor, 9.76k ohm, 1/4W, 5%	1
R17	540 1159 000	Resistor, 100k ohm, 1/2W, 5%	1
R18	548 1364 000	Resistor, 16.2k ohm, 1/4W, 1%	1
R19	540 1170 000	Resistor, 430 ohm, 1/2W, 5%	1
R20	548 1440 000	Resistor, 25.5k ohm, 1/4W, 1%	1
R21	548 0569 000	Resistor, 47.5k ohm, 1/4W, 1%	1
R23	548 0382 000	Resistor, 12.7k ohm, 1/4W, 1%	1
R24	540 1182 000	Resistor, 2200 ohm, 1/2W, 5%	1
R25	548 1399 000	Resistor, 22.6k ohm, 1/4W, 1%	1
R26	540 1111 000	Resistor, 10k ohm, 1/2W, 5%	1
R27	540 1182 000	Resistor, 2200 ohm, 1/2W, 5%	1
R28	540 1159 000	Resistor, 100k ohm,, 1/2W, 5%	1
R29	548 1439 000	Resistor, 17.4k ohm, 1/4W, 1%	1
R30	548 1360 000	Resistor, 8450 ohm, 1/4W, 1%	1
R31	540 1182 000	Resistor, 2200 ohm, 1/2W, 5%	1
R32	548 0780 000	Resistor, 8.66k ohm, 1/4W, 1%	1

Table 6-2. MONO MODULE Circuit Board - 992 4976 001 (Continued)

REF. SYMBOL	HARRIS PART NO.	DESCRIPTION	QTY.
R33	548 1438 000	Resistor, 9.76k ohm, 1/4W, 1%	1
R34	540 1182 000	Resistor, 2200 ohm, 1/2W, 5%	1
R36,R37	540 1151 000	Resistor, 10 ohm, 1/2W, 5%	2
R38	548 0932 000	Resistor, 100k ohm, 1/4W, 1%	1
R39,R40	540 1187 000	Resistor, 1300 ohm, 1/2W, 5%	2
U1	382 0473 000	Integrated Circuit, AD521JD	1
U2,U3	382 0472 000	Integrated Circuit, LM318N	2
U4	382 0359 000	Integrated Circuit, MC7815CP	1
U5	382 0360 000	Integrated Circuit, MC7915CP	1
XU1	404 0674 000	Socket, IC, 14 Contacts	1
XU2,XU3	404 0673 000	Socket, IC, 8 Contacts	2
	612 0901 000	Jack, Printed Circuit Mount	12
	843 1704 001	Printed Board	1

TECHNICAL MANUAL

SCA MODULE

994 7992 001



HARRIS CORPORATION

Broadcast Products Division

T.M. No. 888-1742-003

Printed: October 1977
Revision A: February 1978
Revision B: August 1978
Revision C: March 1979
Revision D: April 1980
Revision E: March 1981
Revision F: June 1981

WARNING

THE CURRENTS AND VOLTAGES IN THIS EQUIPMENT ARE DANGEROUS. PERSONNEL MUST AT ALL TIMES OBSERVE SAFETY REGULATIONS.

This manual is intended as a general guide for trained and qualified personnel who are aware of the dangers inherent in handling potentially hazardous electrical/electronic circuits. It is not intended to contain a complete statement of all safety precautions which should be observed by personnel in using this or other electronic equipment.

The installation, operation, maintenance and service of this equipment involves risks both to personnel and equipment, and must be performed only by qualified personnel exercising due care. HARRIS CORPORATION shall not be responsible for injury or damage resulting from improper procedures or from the use of improperly trained or inexperienced personnel performing such tasks.

During installation and operation of this equipment, local building codes and fire protection standards must be observed. The following National Fire Protection Association (NFPA) standards are recommended as references:

- Automatic Fire Detectors, No. 72E
- Installation, Maintenance, and Use of Portable Fire Extinguishers, No. 10
- Halogenated Fire Extinguishing Agent Systems, No. 12A

WARNING

ALWAYS DISCONNECT POWER BEFORE OPENING COVERS, DOORS, ENCLOSURES, GATES, PANELS OR SHIELDS. ALWAYS USE GROUNDING STICKS AND SHORT OUT HIGH VOLTAGE POINTS BEFORE SERVICING. NEVER MAKE INTERNAL ADJUSTMENTS, PERFORM MAINTENANCE OR SERVICE WHEN ALONE OR WHEN FATIGUED.

Do not remove, short-circuit or tamper with interlock switches on access covers, doors, enclosures, gates, panels or shields. Keep away from live circuits, know your equipment and don't take chances.

WARNING

IN CASE OF EMERGENCY ENSURE THAT POWER HAS BEEN DISCONNECTED.

Treatment of Electrical Shock

1. If victim is not responsive follow the A-B-Cs of basic life support.

PLACE VICTIM FLAT ON HIS BACK ON A HARD SURFACE

A AIRWAY

IF UNCONSCIOUS,
OPEN AIRWAY

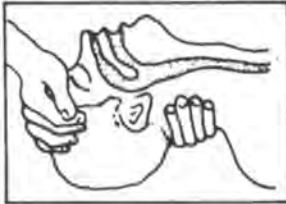

LIFT UP NECK
PUSH FOREHEAD BACK
CLEAR OUT MOUTH IF NECESSARY
OBSERVE FOR BREATHING

B BREATHING

IF NOT BREATHING,
BEGIN ARTIFICIAL
BREATHING



TILT HEAD
PINCH NOSTRILS
MAKE AIRTIGHT SEAL

4 QUICK FULL BREATHS

REMEMBER MOUTH TO MOUTH RESUSCITATION
MUST BE COMMENCED AS SOON AS POSSIBLE

CHECK CAROTID PULSE



IF PULSE ABSENT,
BEGIN ARTIFICIAL
CIRCULATION

C CIRCULATION

DEPRESS STERNUM 1 1/2" TO 2"

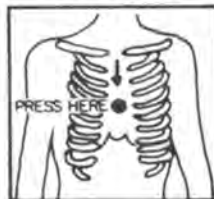

APPROX. { ONE RESCUER
80 SEC. { 15 COMPRESSIONS
2 QUICK BREATHS

APPROX. { TWO RESCUERS
60 SEC. { 5 COMPRESSIONS
1 BREATH



NOTE: DO NOT INTERRUPT RHYTHM OF COMPRESSIONS
WHEN SECOND PERSON IS GIVING BREATH

Call for medical assistance as soon as possible.

2. If victim is responsive.
 - a. keep them warm
 - b. keep them as quiet as possible
 - c. loosen their clothing
(a reclining position is recommended)

FIRST-AID

Personnel engaged in the installation, operation, maintenance or servicing of this equipment are urged to become familiar with first-aid theory and practices. The following information is not intended to be complete first-aid procedures, it is brief and is only to be used as a reference. It is the duty of all personnel using the equipment to be prepared to give adequate Emergency First Aid and thereby prevent avoidable loss of life.

Treatment of Electrical Burns

1. Extensive burned and broken skin
 - a. Cover area with clean sheet or cloth. (Cleanest available cloth article.)
 - b. Do not break blisters, remove tissue, remove adhered particles of clothing, or apply any salve or ointment.
 - c. Treat victim for shock as required.
 - d. Arrange transportation to a hospital as quickly as possible.
 - e. If arms or legs are affected keep them elevated.

NOTE

If medical help will not be available within an hour and the victim is conscious and not vomiting, give him a weak solution of salt and soda: 1 level teaspoonful of salt and 1/2 level teaspoonful of baking soda to each quart of water (neither hot or cold). Allow victim to sip slowly about 4 ounces (a half of glass) over a period of 15 minutes. Discontinue fluid if vomiting occurs. (Do not give alcohol.)

2. Less severe burns - (1st & 2nd degree)
 - a. Apply cool (not ice cold) compresses using the cleanest available cloth article.
 - b. Do not break blisters, remove tissue, remove adhered particles of clothing, or apply salve or ointment.
 - c. Apply clean dry dressing if necessary.
 - d. Treat victim for shock as required.
 - e. Arrange transportation to a hospital as quickly as possible.
 - f. If arms or legs are affected keep them elevated.

REFERENCE: ILLINOIS HEART ASSOCIATION

AMERICAN RED CROSS STANDARD FIRST AID AND PERSONAL SAFETY MANUAL
(SECOND EDITION)

TABLE OF CONTENTS

<u>Paragraph</u>		<u>Page</u>
SECTION I. GENERAL DESCRIPTION		
1-1.	Equipment Purpose	1
1-3.	Technical Characteristics	1
SECTION II. INSTALLATION		
2-1.	General	1
SECTION III. CONTROLS AND INDICATORS		
3-1.	General	1
SECTION IV. PRINCIPLES OF OPERATION		
4-1.	Circuit Description	11
4-2.	Input Circuit	11
4-3.	Audio Preamplifier	11
4-4.	Active Low-Pass Filter	11
4-5.	SCA Generation	11
4-6.	Voltage Controlled Oscillator	11
4-7.	Output Circuit	11
4-8.	Mute Circuit	12
4-10.	Level Detector	12
4-11.	Delay Timer	12
4-13.	Control Circuit	12
4-16.	Power Up Mode Selection	15
4-17.	Remote Control	15
4-18.	Mode Indicators	15
4-19.	Power	15
SECTION V. MAINTENANCE		
5-1.	Corrective Maintenance	15
5-3.	Troubleshooting	15
SECTION VI. PARTS LIST		
6-1.	General	30

LIST OF TABLES

<u>Table</u>	<u>Page</u>
1-1. Technical Characteristics	2
3-1. SCA MODULE Controls and Indicators	4
3-2. Control Adjustments	6
5-1. SCA MODULE Fault Isolation Index	17
5-2. SCA MODULE Parts Index	19
6-1. SCA MODULE Front Panel	31
6-2. SCA MODULE Circuit Board	32

LIST OF ILLUSTRATIONS

<u>Figure</u>	<u>Page</u>
3-1. SCA MODULE	3
4-1. SCA MODULE Block Diagram	13
5-1. SCA MODULE Parts Layout	18
5-2. SCA MODULE Waveforms	21
5-3. SCA MODULE Schematic	23
5-4. No Output (Modulation Meter Indicates Activity)	25
5-5. No Output (Modulation Meter Indicates No Activity)	26
5-6. Muting Inoperative (On Indicator Out)	27
5-7. Local and Remote Mode Selection Inoperative (Any Mode)	28
5-8. SCA To Stereo Crosstalk	29

SECTION I

GENERAL DESCRIPTION

1-1. EQUIPMENT PURPOSE

1-2. The SCA MODULE accepts an ac coupled audio or dc coupled input signal such as slow scan television and produces a 41 kHz or 67 kHz frequency modulated SCA subcarrier at the level required to drive the MOD OSC module input circuitry. Selectable manual or automatic muting and programmable pre-emphasis of 150 us, 75 us, 50 us, or flat response are provided. Local and remote switching provisions and module front panel indicators provide convenient SCA operation.

1-3. TECHNICAL CHARACTERISTICS

1-4. Table 1-1 lists operating characteristics and parameters of the MS-15 SCA MODULE.

SECTION II

INSTALLATION

2-1. GENERAL

2-2. Refer to 888 1742 001, MS-15 FM Exciter, Section II, Installation.

SECTION III

CONTROLS AND INDICATORS

3-1. GENERAL

3-2. Figure 3-1 shows the location of each control or indicator associated with the MS-15 SCA MODULE and table 3-1 lists the controls and indicators with a description of each item listed. Control setup adjustments are listed in table 3-2.

Table 1-1. Technical Characteristics

FUNCTION	CHARACTERISTIC
<u>INPUTS</u>	
Power:	+20 Vdc @ 0.060 amperes -20 Vdc @ 0.040 amperes
Signal: AC	+10 dBm <u>+1</u> dB for 100% modulation at 400 Hz @ 600 ohms
DC	1.0V peak for 5 kHz deviation @ 2000 ohms
Control: Remote Switching	+18V to +24 Vdc, momentary level
<u>OUTPUTS</u>	
Signal:	100 millivolts RMS composite SCA for 10% injection. (Adjustable from 0 to 30% injection.)
Control: SCA-2 inhibit	+6 Vdc for inhibit -6 Vdc for operate

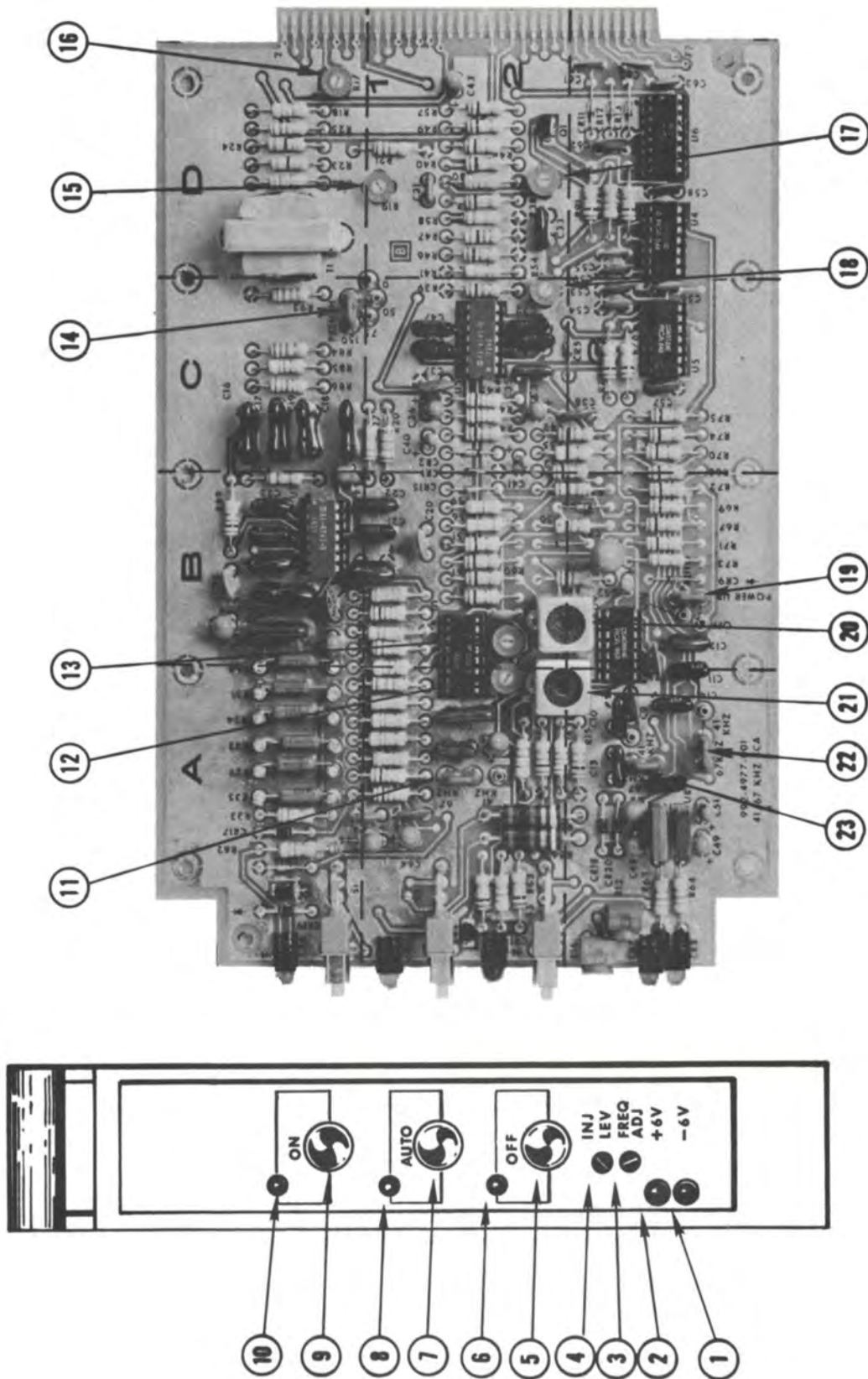

1742-44

Figure 3-1. SCA MODULE

Table 3-1. SCA MODULE Controls and Indicators

REF.	CONTROL/INDICATOR	FUNCTION
1	-6V Indicator (CR8)	Illuminates to indicate the SCA MODULE -6 volt regulator is operational.
2	+6V Indicator (CR7)	Illuminates to indicate the SCA MODULE +6 volt regulator is operational.
3	FREQ ADJ Control (R12)	Adjusts the center frequency of the SCA subcarrier.
4	INJ LEV Control (R16)	Adjusts the output level of the SCA subcarrier.
5	OFF Switch (S3)	Inhibits operation of the SCA channel.
6	OFF Indicator (CR14)	Indicates operation of the SCA channel is inhibited when illuminated.
7	AUTO Switch (S2)	Enables circuitry on the SCA MODULE to automatically mute the SCA carrier if the SCA audio input mutes.
8	AUTO Indicator (CR10)	Indicates the SCA AUTO mode of operation is enabled when illuminated.
9	ON Switch (S1)	Enables the SCA carrier.
10	ON Indicator (CR6)	Indicates the presence of SCA subcarrier when illuminated.
11	41 KHZ/67 KHZ SCA Frequency Jumper (J1)	Programs SCA channel frequency.
12	Waveform Adjust Control (R2)	Adjusts the SCA oscillator waveform for minimum odd harmonic distortion.
13	Symmetry Adjust Control (R6)	Adjusts the SCA oscillator waveform for symmetry and minimum even harmonic distortion.
14	PREMPH 150/75/50/0 pre-emphasis Jumper (J5)	Selects SCA MODULE input pre-emphasis.

Table 3-1. SCA MODULE Controls and Indicators (Continued)

REF.	CONTROL/INDICATOR	FUNCTION
15	AUDIO INPUT LEVEL Control (R19)	Adjusts signal level input to the SCA generator circuit.
16	D.C. INPUT LEVEL Control (R17)	Adjusts level of dc coupled input signal.
17	MUTE LEVEL Control (R38)	Adjust threshold level at which SCA subcarrier appears.
18	MUTE DELAY Control (R54)	Adjusts the time delay between the last modulating signal and muting of the SCA subcarrier.
19	POWER UP OFF/ON/AUTO Jumper (J4)	Determines module operational status at power application (SCA on, SCA auto, SCA off). (Factory set for auto.)
20	Primary Tuning Control (L1)	Tunes primary circuit of doubly tuned SCA bandpass filter.
21	Secondary Tuning Control (L2)	Tunes secondary circuit of doubly tuned SCA bandpass filter.
22	41 KHZ/67 KHZ Bandpass Filter Tuning Jumper (J3)	Selects center frequency of bandpass filter output circuit (41 kHz or 67 kHz).
23	41 KHZ/67 KHZ Bandpass Filter Tuning Jumper (J2)	Selects center frequency of bandpass filter input circuit (41 kHz or 67 kHz).

Table 3-2. Control Adjustments

CONTROL	ADJUSTMENT
<p>FREQ ADJ Control (R12)</p>	<ol style="list-style-type: none"> 1. Connect the exciter rf output to a 50 ohm load through a directional coupler or line sampler. 2. Connect a modulation monitor to the line sampler or the forward port of the directional coupler. 3. Connect an SCA monitor to the SCA provision on the modulation monitor. 4. Remove the STEREO ANALOG module from the exciter. 5. Ensure there is no modulation applied to the SCA module. 6. Depress the SCA ON switch. The ON indicator will illuminate. 7. Adjust R12 to the proper SCA frequency (41 kHz or 67 kHz) as indicated by the SCA monitor. 8. Reconnect the exciter output to the load, replace the STEREO ANALOG module in the exciter, and reapply modulation to the SCA module.
<p>INJ LEV Control (R16)</p>	<p>Refer to the MOD OSC module SCA-1 LEVEL SHIFT Control (R54)/SCA-2 LEVEL SHIFT Control (R55) adjustment procedure (888-1742-008).</p>
<p>D.C. INPUT LEVEL Control (R17)</p>	<ol style="list-style-type: none"> 1. Connect the exciter rf output to a 50 ohm load through a directional coupler or line sampler.
<p>AUDIO INPUT LEVEL Control (R19)</p>	<ol style="list-style-type: none"> 2. Connect a modulation monitor to the line sampler or the forward port of the directional coupler.

Table 3-2. Control Adjustments (Continued)

CONTROL	ADJUSTMENT
<p>MUTE LEVEL Control (R38)</p>	<ol style="list-style-type: none"> 3. Connect an SCA monitor to the SCA provision on the modulation monitor. 4. Remove the module. Mount the module in the exciter using the extender board provided with the exciter. 5. Depress the SCA MODULATION meter switch and ensure the SCA level input to the exciter is correct (see table 1-1). 6. Depress the SCA ON switch. The ON indicator will illuminate. 7. Depress the SCA MODULATION meter switch. If the SCA ac coupled input is used, adjust the audio input level to obtain a 100% MODULATION meter indication and adjust R19 to obtain a SCA monitor indication of 5 kHz deviation. If the SCA dc coupled input is used, adjust R17 to obtain a 100% MODULATION meter indication and adjust R19 to obtain an SCA monitor indication of 5 kHz deviation. * 8. Remove the module and extender board, replace the module in the exciter, and reconnect the exciter to the load. <ol style="list-style-type: none"> 1. Remove the module. Mount the module in the exciter using the extender board provided with the exciter. 2. Depress the SCA MODULATION meter switch and ensure the SCA level input to the exciter is correct (see table 1-1).

Table 3-2. Control Adjustments (Continued)

CONTROL	ADJUSTMENT
<p>MUTE DELAY Control (R54)</p>	<ol style="list-style-type: none"> 3. Adjust R38 fully clockwise. 4. Depress the SCA AUTO switch. The AUTO indicator will illuminate. 5. Adjust R38 counterclockwise until the ON indicator illuminates. 6. Remove the module and extender board and replace the module in the exciter. 1. Remove the module. Mount the module in the exciter using the extender board provided with the exciter. 2. Depress the SCA MODULATION meter switch and ensure the SCA audio levels input to the exciter are correct (see table 1-1). 3. Adjust R54 fully counterclockwise. 4. Depress the SCA AUTO switch. The AUTO indicator and the ON indicator will illuminate. 5. Interrupt the SCA audio feed to the exciter. The ON indicator will immediately go out. 6. Apply and remove the SCA audio to the exciter and adjust R54 until the ON indicator remains illuminated for the desired time delay.

Table 3-2. Control Adjustments (Continued)

CONTROL	ADJUSTMENT
<p>Primary Tuning Control (L1)</p> <p>SECONDARY TUNING Control (L2)</p> <p>Symmetry Adjust Control (R6)</p>	<ol style="list-style-type: none"> 7. Remove the module and extender board and replace the module in the exciter. Ensure the audio feed is connected to the SCA module. 1. Connect the exciter rf output to a 50 ohm load through a directional coupler or line sampler. 2. Connect a modulation monitor to the line sampler or the forward port of the directional coupler. 3. Connect an SCA monitor to the SCA provision on the modulation monitor. 4. Remove the module from the exciter and remove the side cover. 5. Mount the module in the exciter using the extender board provided with the exciter. 6. Depress the SCA ON switch. The SCA ON indicator will illuminate. 7. Adjust L1 or L2 to peak the SCA monitor injection indication. 8. Remove the extender board, replace the module side cover, and replace the module in the exciter. Reconnect the exciter to the load. 1. Remove the module from the exciter and remove the side cover.

Table 3-2. Control Adjustments (Continued)

CONTROL	ADJUSTMENT
<p>Waveform Adjust Control (R2)</p>	<ol style="list-style-type: none"> 2. Mount the module in the exciter using the extender board provided with the exciter. 3. Connect a low frequency spectrum analyzer between test point TP3 and ground. 4. Adjust R6 to obtain a minimum second harmonic indication. 5. Disconnect the spectrum analyzer from the module, remove the extender board, replace the module side cover, and replace the module in the exciter. <ol style="list-style-type: none"> 1. Remove the module from the exciter and remove the side cover. 2. Mount the module in the exciter using the extender board provided with the exciter. 3. Connect a low frequency spectrum analyzer between test point TP3 and ground. 4. Perform the Symmetry Adjust Control (R6) procedure. 5. Adjust R2 to obtain a minimum odd harmonic indication. 6. Disconnect the spectrum analyzer from the module, remove the extender board, replace the module side cover, and replace the module in the exciter.
<p>* SCA modules are normally supplied with 100% modulation equal to <u>+5</u> kHz deviation.</p>	

SECTION IV

PRINCIPLES OF OPERATION

4-1. CIRCUIT DESCRIPTION

4-2. INPUT CIRCUIT

4-3. AUDIO PREAMPLIFIER. Audio is applied to the SCA MODULE through a pad consisting of R22, R23, R24, and R25 which provides a 600 ohm balanced resistive module input impedance to the primary of transformer T1 (refer to figure 4-1). Audio from the transformer secondary is applied to the pre-emphasis network which provides selection of 150 us, 75 us, or flat response as determined by the position of jumper J5. The audio is applied with signal from the dc coupled input to audio preamplifier U2A. The D.C. INPUT LEVEL control (R17) provides adjustment of the dc input signal level.

4-4. ACTIVE LOW-PASS FILTER. The active low-pass filter comprises U2A, U2B, U2C, and U2D which are used as active elements in a seven pole Butterworth low-pass filter. The filter provides 42 dB per octave attenuation above 4.5 kHz. However, the filter cutoff frequency may be moved to 5.0 kHz or 7.5 kHz as desired by changing resistor values as noted on figure 5-3. The entire active low-pass filter may be bypassed for special SCA requirements (see figure 4-1). The output of the active low-pass filter is applied to the ac meter module, the mute circuit audio amplifiers and the voltage controlled oscillator in the rf circuit.

4-5. SCA GENERATION

4-6. VOLTAGE CONTROLLED OSCILLATOR. Input signal to the voltage controlled oscillator is level adjusted by the AUDIO INPUT LEVEL control (R19) and applied to the FM input of the monolithic function generator. The oscillator generates the 41 kHz or 67 kHz SCA subcarrier as programmed by jumper J1. The center frequency of the SCA carrier is adjusted by the FREQ ADJ control (R12). With the symmetry adjust control (R6) and the WAVEFORM ADJUST control (R2) correctly adjusted for minimum distortion, harmonics will be suppressed a minimum of 45 dB below the fundamental frequency.

4-7. OUTPUT CIRCUIT. The SCA signal generated by the voltage controlled oscillator is applied to a doubly tuned bandpass filter in which J2 and J3 determine the coupling and center frequency of the filter for operation on 41 kHz or 67 kHz. This filter attenuates the residual harmonic content in the SCA carrier by more than 70 dB. The primary of the filter is tuned by L1 and the secondary circuit is adjusted by L2. The INJ LEV control (R16) allows adjustment of the SCA module to 100 millivolts for 10% modulation as required to drive the MOD OSC module circuitry. When the SCA module is disabled, CMOS switches U9A and U9B inhibit operation by disconnecting the input to the bandpass filter and shorting the module output to ground.

4-8. MUTE CIRCUIT

4-9. The SCA mute circuit consists of an audio level detector and a delay timer. If the audio input level falls below a preset threshold or is interrupted for a period longer than an adjustable time delay, the SCA channel output will mute until the audio is reapplied. The SCA threshold sensitivity is adjustable from 0 dBm to -30 dBm by the MUTE LEVEL control (R38) and the SCA delay is adjustable from 0.5 to 20 seconds by the MUTE DELAY control (R54).

4-10. LEVEL DETECTOR. A high gain audio amplifier consisting of U3A and U3B provides the required amplification to increase the audio level from the active low-pass filter to the level necessary to drive the peak rectifier circuit. After amplification, the audio is applied to a peak detector comprising CR1, CR2, and associated circuitry. The resultant charge is stored in capacitor C41. As long as the potential of the peak detected audio is greater than the dc reference applied to the threshold comparator by R47 and R48, comparator U3C applied +6 volts to the delay timer circuit.

4-11. DELAY TIMER. As long as an active +6 Vdc output is applied from the threshold comparator, capacitor C45 will remain fully charged and the delay comparator (U3D) will output a +6 Vdc level. The output of U3D closes the series switches in U9A and opens the parallel switches in U9B through inverter U4D, turns on driver Q3 which illuminates the ON indicator, and provides an SCA ON signal to the MOD OSC module. The SCA ON signal from SCA module No. 2 is also applied to the STEREO DIGITAL module to prevent simultaneous 41 kHz SCA and stereophonic operation to prevent mutual interference. The SCA channel is given priority in this situation and the STEREO DIGITAL module is automatically switched to a predetermined monaural mode.

4-12. If the audio input is interrupted, the charge on capacitor C45 will discharge through the MUTE DELAY control (R54). When the charge on C45 falls below the dc level applied to the delay comparator through R56 and R58, the delay comparator outputs a LOW state and mutes the SCA channel output. Diode CR4 provides isolation to prevent C45 from discharging through U3C.

4-13. CONTROL CIRCUIT

4-14. Mode selection is performed by two dc flip flops implemented by four cross coupled NAND gates. The dc flip flops are controlled by logic levels rather than transitions. When a mode is selected, either by depressing a mode switch or applying an input on the selected remote control input provision, a momentary LOW (-6) Vdc sets or resets each flip flop. The U4A/U5A flip flop is set (U4A HIGH) when the SCA ON mode, the U4B/U5B flip flop is set (U4B HIGH) when in the SCA OFF mode, and in the AUTO mode both flip flops are reset and U4C outputs a LOW.

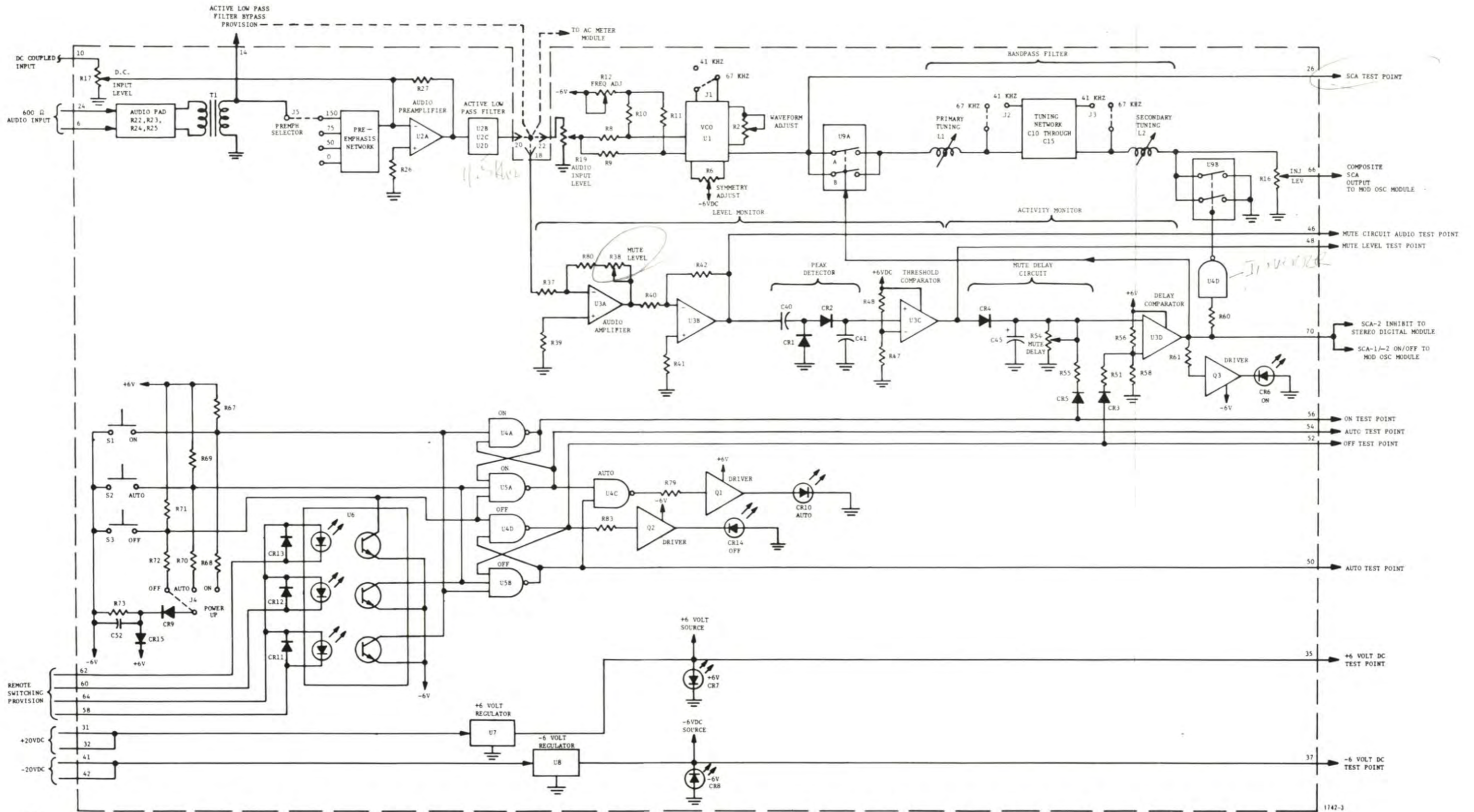

NOTES:
 1. PINS 1,3,5,7,9,11,13,15,17,19,
 21,23,25,27,45,47,49,51,53,55,
 57,59,61,63,65,67,68,69,71,72
 CONNECT TO GROUND.

FIGURE 4-1. SCA MODULE BLOCK DIAGRAM

4-15. When the SCA ON is selected the positive input to comparator U3B is driven HIGH through diode CR5. When SCA OFF is selected, the negative input to comparator U3D is forced HIGH through diode CR3. Either action overrides the mute circuit function and manually turns the SCA carrier on or off. In the AUTO mode, diodes CR3 and CR5 are both off which allows the automatic muting function to operate.

4-16. POWER UP MODE SELECTION. When power is applied, capacitor C52 is discharged. Until the capacitor charges through diode CR15, a low condition exists on the mode selection line determined by the position of jumper J4. This will initialize the equipment in the selected mode at power application. Resistor R73 discharges C52 when power is removed.

4-17. REMOTE CONTROL. Remote control mode selection is provided by optical isolator U6. The input side of the optical isolator is protected from reverse bias by diodes CR11, CR12, and CR13. Current limiting resistors for each remote control input are located on the RFI filter. Remote control mode selection consists of application of a positive 18 to 24 Vdc potential on the particular input line.

4-18. MODE INDICATORS. Light emitting diodes connect to the control gates through drivers and illuminate when each mode is selected. The ON indicator illuminates to indicate selection of the ON mode and functions as a mute circuit status indicator when the AUTO mode is selected. The AUTO indicator illuminates when AUTO is selected and the OFF indicator illuminates when module operation is inhibited by selection of the OFF mode.

4-19. POWER

4-20. Positive 20 Vdc enters the module on pins 31 and 32 and negative 20 Vdc enters the module on pins 41 and 42. A regulated potential to operate the module internal circuitry is developed by regulators U7 (+6 Vdc) and U8 (-6 Vdc). Light emitting diodes CR7 (+6V) and CR8 (-6 Vdc) indicate operation of the two regulators. Positive and negative six volt test points are provided to assist in checking the regulator outputs.

SECTION V

MAINTENANCE

5-1. CORRECTIVE MAINTENANCE

5-2. The MS-15 FM Exciter module maintenance philosophy consists of problem isolation to a specific area or individual component and subsequent isolation and replacement of the defective component.

5-3. TROUBLESHOOTING

5-4. In event of problems, the trouble area must first be isolated to a specific area. Most troubleshooting consists of visual checks. The MODULATION meter, MULTIMETER, fuse F1, circuit breaker CB1, and the indicators on

each module should be used to determine in which area the malfunction exists. All module power supplies are equipped with LEDs which indicate the module power supply status. A single dark LED would indicate a problem associated with an individual module monolithic voltage regulator. A consistent pattern of dark LEDs however, would indicate an exciter dc distribution bus fault.

5-5. Once the trouble is isolated to a specific area, refer to the theory section of this manual for circuit discussion to aid in problem resolution. Table 5-1 lists typical trouble symptoms pertaining to the individual module operation with references to fault isolation diagrams listing probable causes and corrective actions. A corrective action given for a trouble symptom is not necessarily the only answer to a problem. It only tends to lead the repairman into the area that may be causing the trouble. An extender board (HARRIS PN 992 4989 001) is provided with the exciter to assist in troubleshooting. In event parts are required, refer to Section VI, Parts List. The following information is contained in this section as an aid to maintenance:

<u>REFERENCE</u>	<u>TITLE</u>	<u>NUMBER</u>
Figure 5-1	SCA MODULE Parts Layout	--- ---- ---
Table 5-2	SCA MODULE Parts Index	--- ---- ---
Figure 5-2	SCA MODULE Waveforms	--- ---- ---
Figure 5-3	SCA MODULE Schematic	843 1696 001

Table 5-1. SCA MODULE Fault Isolation Index

SYMPTOM	DEFECT/REFERENCE
NOT OUTPUT (modulation meter indicates activity)	Figure 5-4
NO OUTPUT (modulation meter indicates no activity)	Figure 5-5
MUTING INOPERATIVE (ON indicator out).	Figure 5-6
LOCAL AND REMOTE MODE SELECTION INOPERATIVE (any mode).	Figure 5-7
REMOTE MODE SELECTION INOPERATIVE (any mode).	Defective U6
SCA TO STEREO CROSSTALK	Figure 5-8

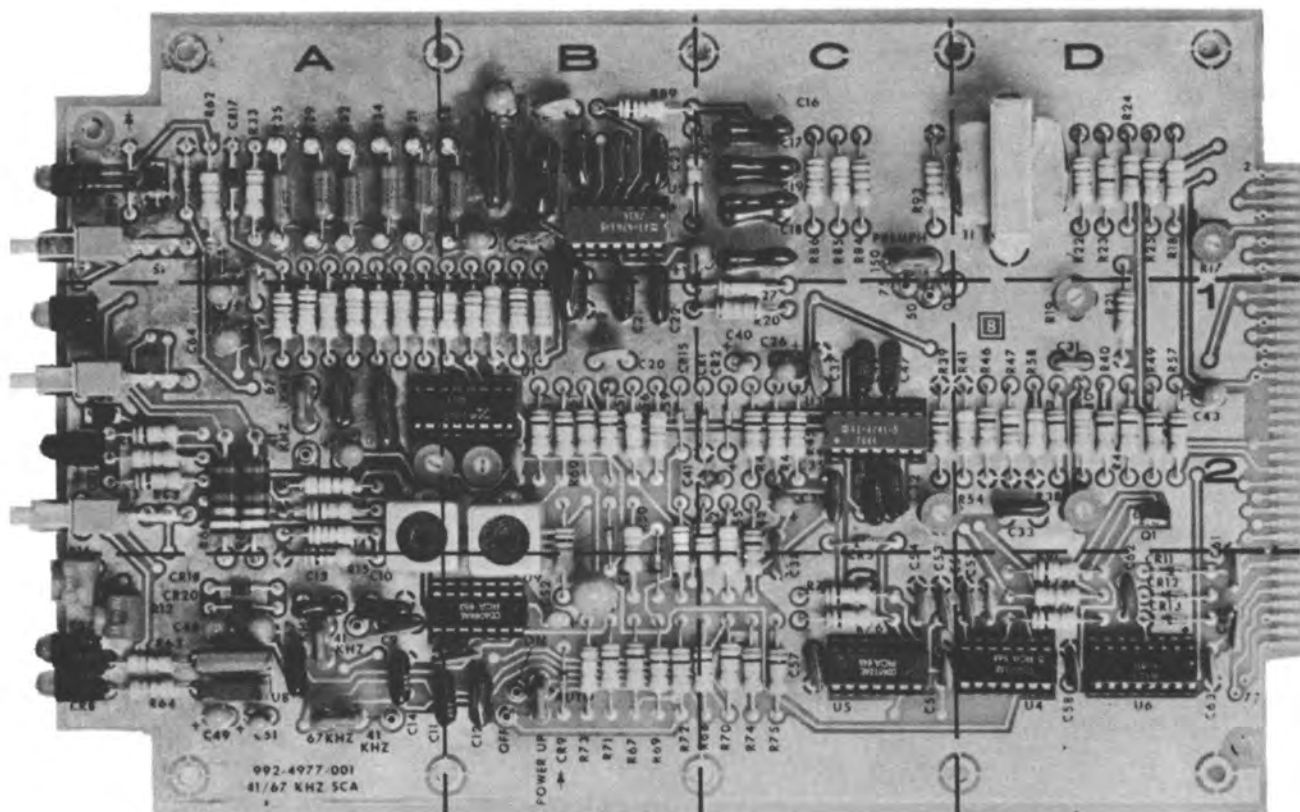

1742-45

Figure 5-1. SCA MODULE Parts Layout

Table 5-2. SCA MODULE Parts Index

SYMBOL	LOCATION	SYMBOL	LOCATION	SYMBOL	LOCATION	SYMBOL	LOCATION	SYMBOL	LOCATION
C1	A2	C29	B2	C57	C3	CR17	A1		
C2	A2	C30	B1	C58	D3	CR18	A3		
C3	B1	C31	D2	C59	D3	CR19	A1		
C4	A1	C32	C2	C60	D3	CR20	A3		
C5	A2	C33	D2	C61	D3				
C6	A2	C34	C2	C62	D3				
C7	B2	C35	C2	C63	D3	J1	A2		
C8	B3	C36	C2	C64	A2	J2	A3		
C9	A3	C37	C2	C65	B1	J3	A3		
C10	A3	C38	C2	C66	B1	J4	B3		
C11	A3	C39	C2			J5	C1		
C12	B3	C40	C2						
C13	A3	C41	B2	CR1	C2				
C14	A3	C42	C2	CR2	C2	Q1	D2		
C15	A3	C43	D2	CR3	B3	Q2	A2		
C16	C1	C44	A1	CR4	B3	Q3	A1		
C17	C1	C45	B3	CR5	C2				
C18	C1	C46	--	CR6	A1				
C19	C1	C47	C2	CR7	A3				
C20	B2	C48	A3	CR8	A3	L1	B2		
C21	B2	C49	A3	CR9	B3	L2	A2		
C22	B2	C50	A3	CR10	A2				
C23	B1	C51	A3	CR11	D3				
C24	B1	C52	B3	CR12	D3	R1	A2		
C25	B1	C53	C3	CR13	D3	R2	A2		
C26	B1	C54	C3	CR14	A2	R3	B2		
C27	B1	C55	D3	CR15	B2	R4	B2		
C28	B1	C56	C3	CR16	A1	R5	A2		

Table 5-2. SCA MODULE Parts Index (Continued)

SYMBOL	LOCATION	SYMBOL	LOCATION	SYMBOL	LOCATION	SYMBOL	LOCATION	SYMBOL	LOCATION
R6	B2	R34	A1	R62	A1	R90	A1	R62	A1
R7	B2	R35	A1	R63	A1	R91	A3	R63	A3
R8	A2	R36	B2	R64	A3	R92	A3	R64	A3
R9	A2	R37	D2	R65	D2	R93	A2	R65	A2
R10	A2	R38	D2	R66	D2		A2	R66	A2
R11	A2	R39	C2	R67	C2		B3	R67	B3
R12	A3	R40	D2	R68	D2		B3	R68	B3
R13	A2	R41	C2	R69	C2		B3	R69	B3
R14	A2	R42	C2	R70	C2		C3	R70	C3
R15	A3	R43	C2	R71	C2		B3	R71	B3
R16	A3	R44	C2	R72	C2		B3	R72	B3
R17	D1	R45	C2	R73	C2		B3	R73	B3
R18	D1	R46	D2	R74	D2		C3	R74	C3
R19	D2	R47	D2	R75	D2		C3	R75	C3
R20	C2	R48	D2	R76	D2		C3	R76	C3
R21	D2	R49	D2	R77	D2		C3	R77	C3
R22	D1	R50	B2	R78	D2		D2	R78	D2
R23	D1	R51	B2	R79	B2		D2	R79	D2
R24	D1	R52	C2	R80	C2		D2	R80	D2
R25	D1	R53	B3	R81	B3		B2	R81	B2
R26	B2	R54	C2	R82	C2		A2	R82	A2
R27	C2	R55	C2	R83	C2		A2	R83	A2
R28	A1	R56	B2	R84	B2		C1	R84	C1
R29	A1	R57	D2	R85	D2		C1	R85	C1
R30	B1	R58	D2	R86	D2		C1	R86	C1
R31	A1	R59	B2	R87	B2		A2	R87	A2
R32	A1	R60	B2	R88	B2		A2	R88	A2
R33	A1	R61	B2	R89	B2		B1	R89	B1

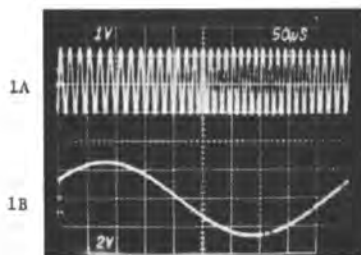

TEST REQUIREMENTS: 2 kHz modulation @±5 kHz deviation

1A Function generator output at TP-3.

1B U2D pin 8.

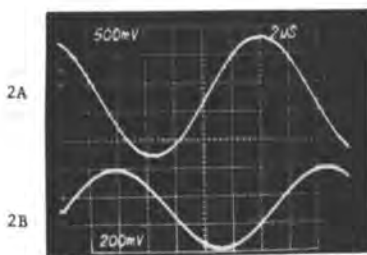

TEST REQUIREMENTS: A. No signal applied to exciter audio inputs.
B. SCA turned on.

2A Function generator output at TP-3.

2B SCA output at module pin 66.

1742-00

Figure 5-2. SCA MODULE Waveforms

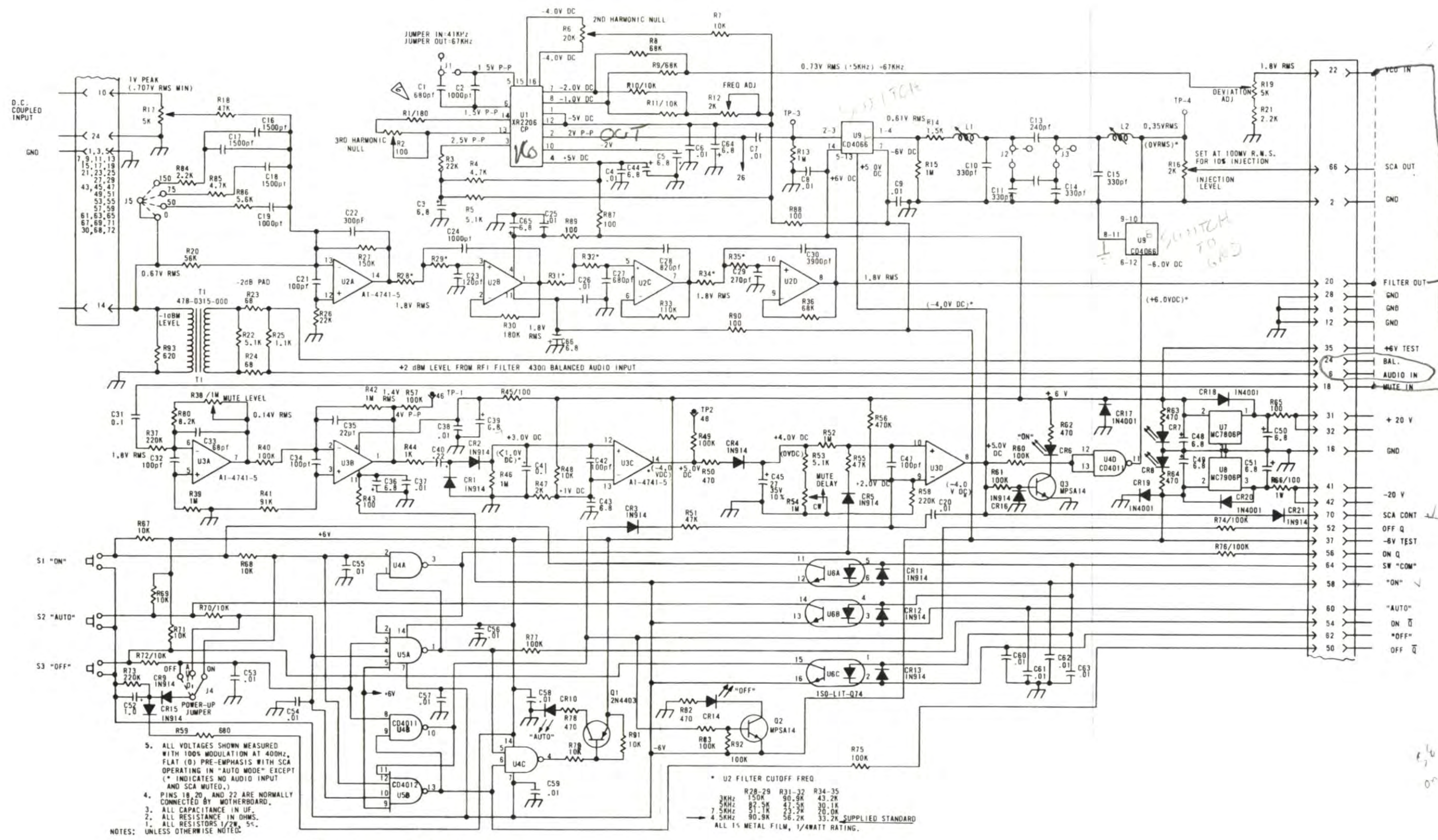
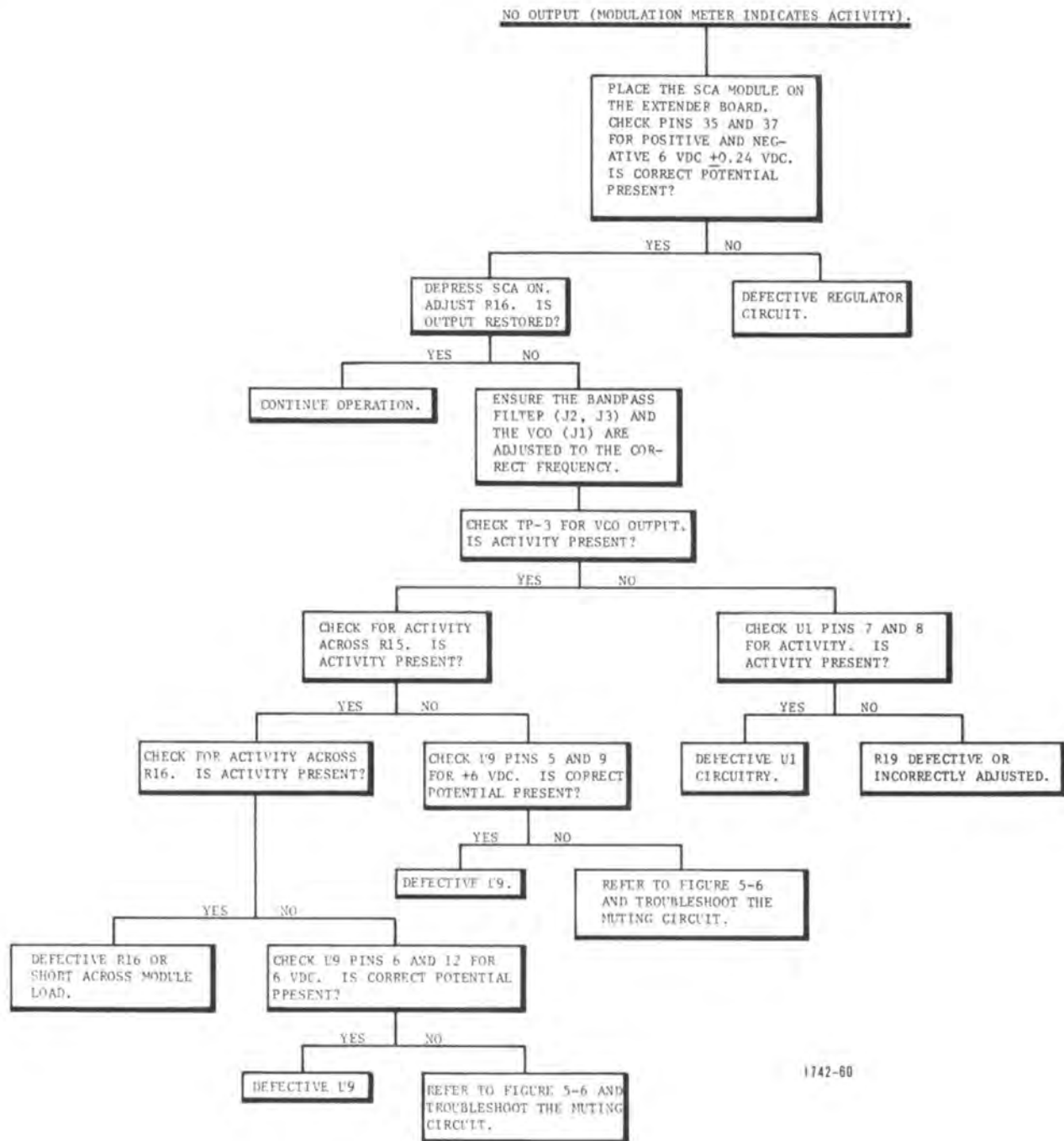

FIGURE 5-3. SCA MODULE SCHEMATIC 843 1696 001



1742-60

Figure 5-4. No Output (Modulation Meter Indicates Activity)

NO OUTPUT (MODULATION METER INDICATES NO ACTIVITY)

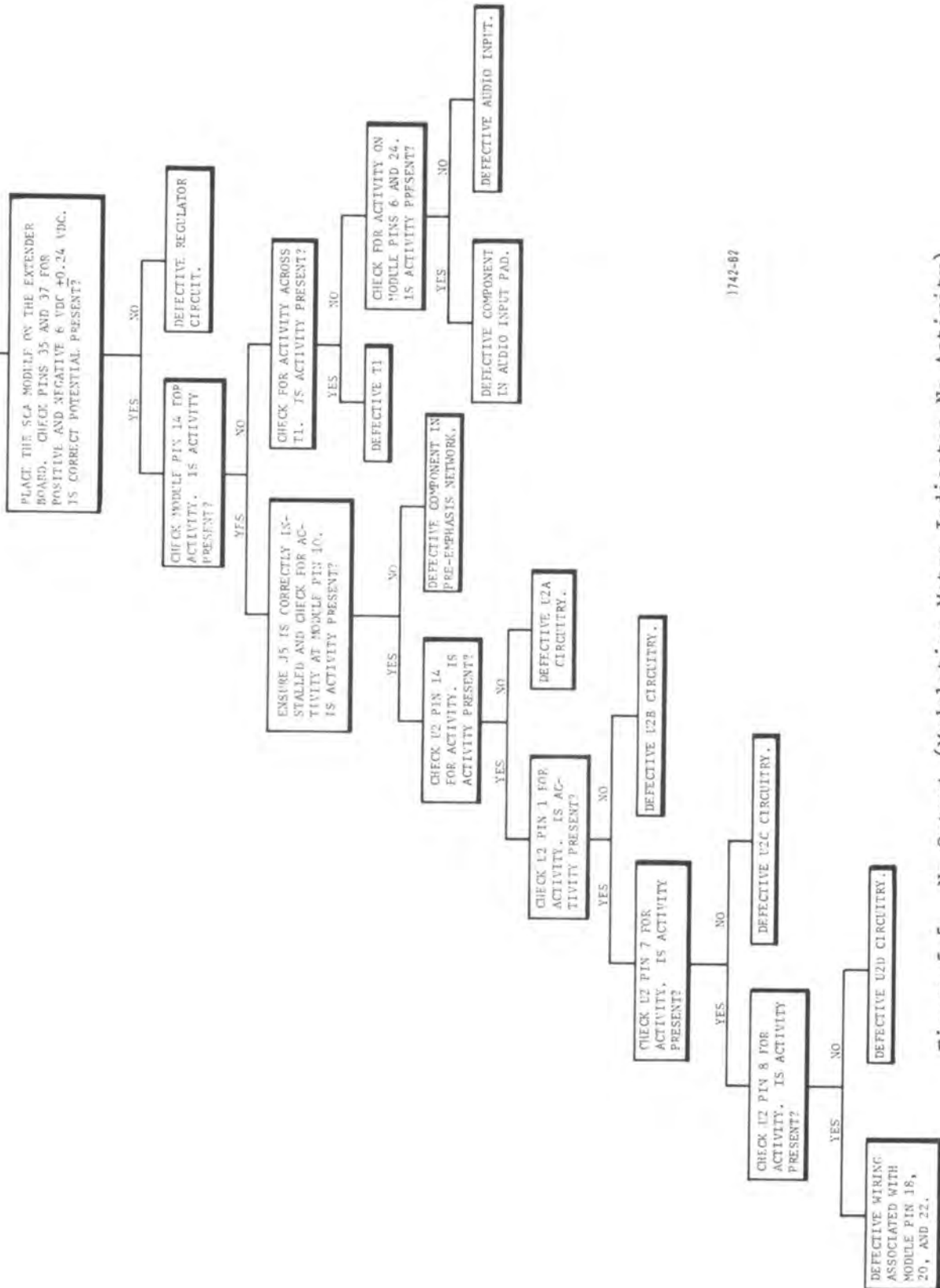

1742-81

Figure 5-5. No Output (Modulation Meter Indicates No Activity)

MUTING INOPERATIVE (ON INDICATOR OUT)

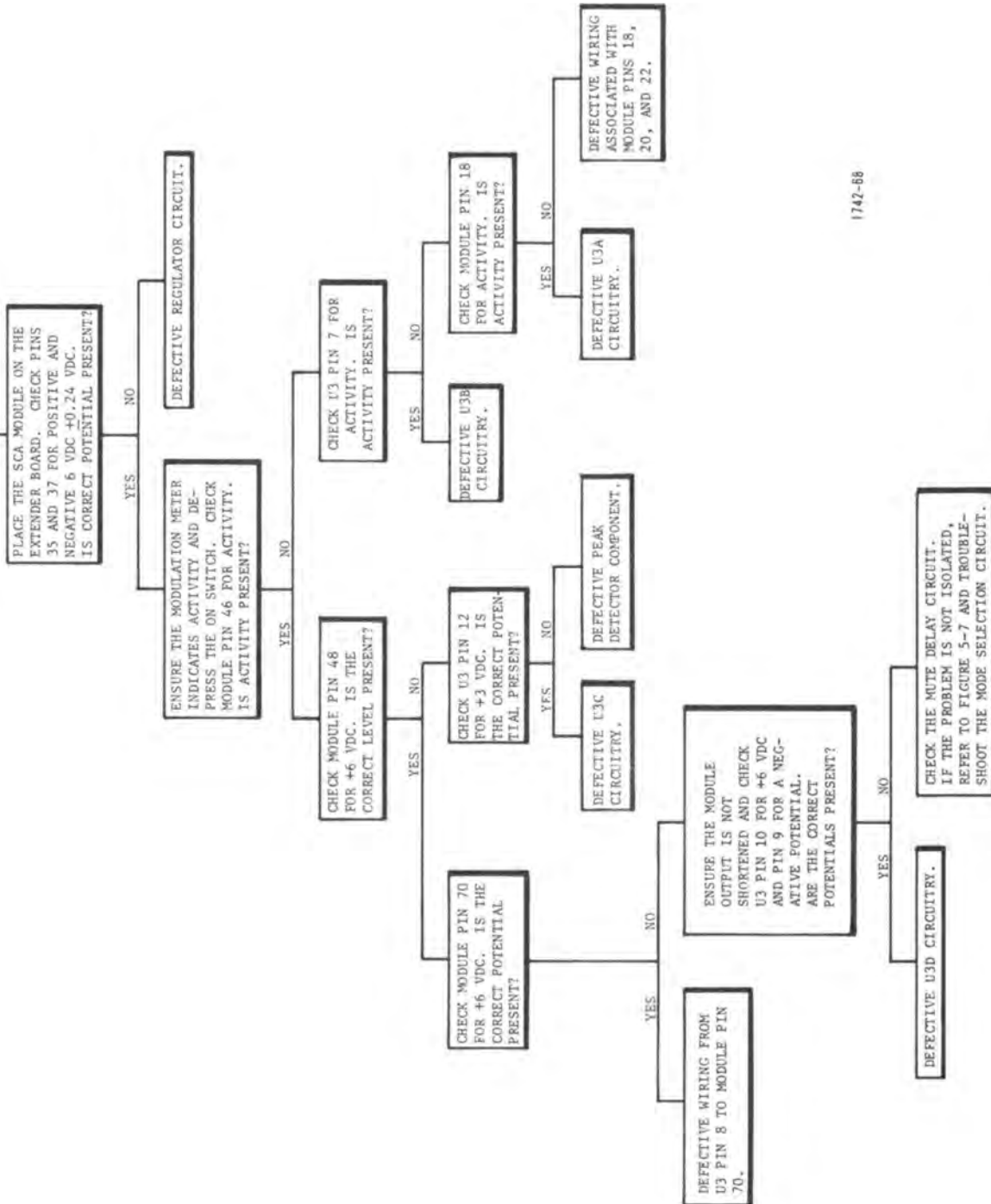

1742-68

Figure 5-6. Muting Inoperative (On Indicator Out)

LOCAL AND REMOTE MODE SELECTION INOPERATIVE (ANY MODE)

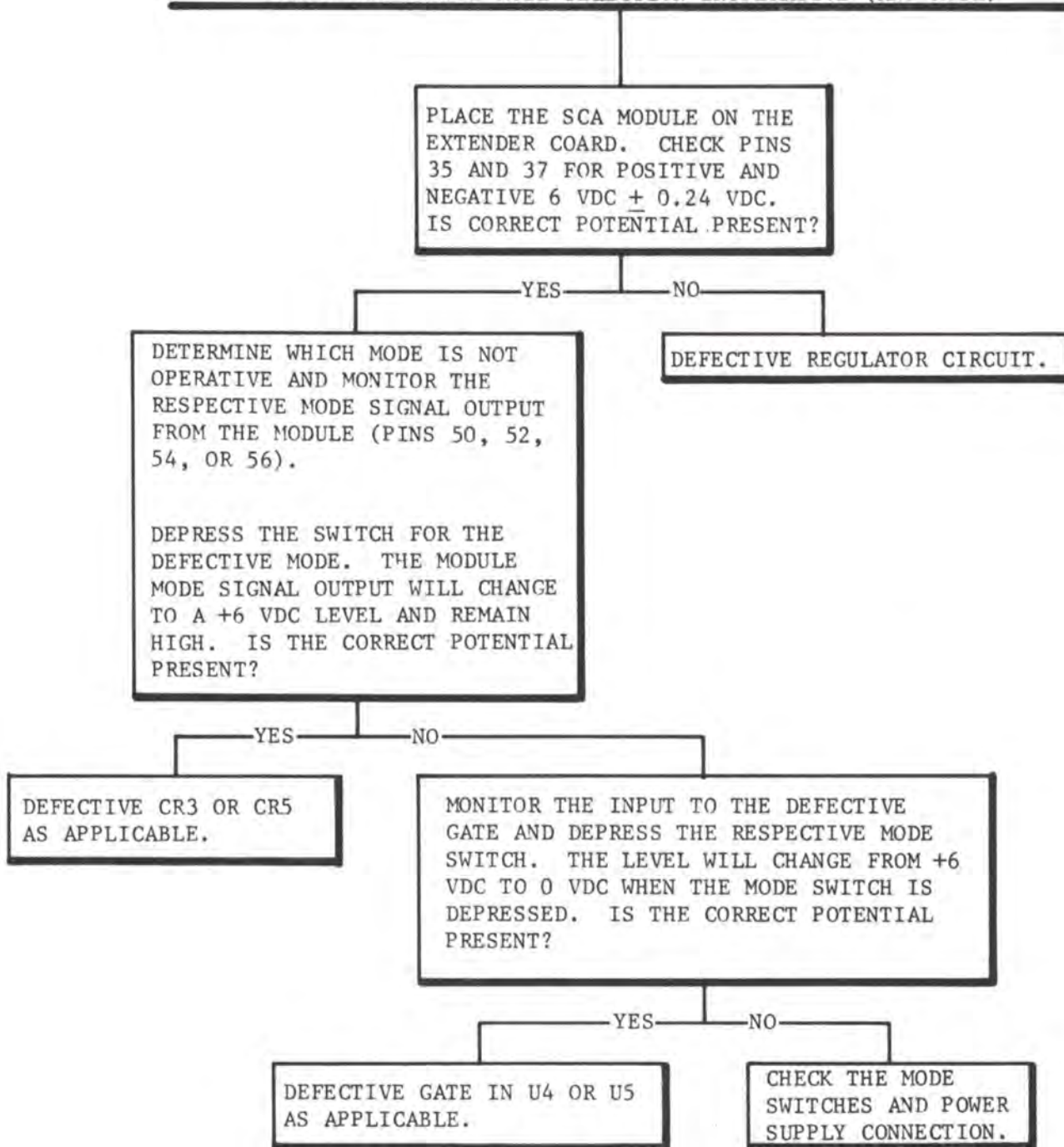

1742-94

Figure 5-7. Local and Remote Mode Selection Inoperative (Any Mode)

SCA TO STEREO CROSSTALK

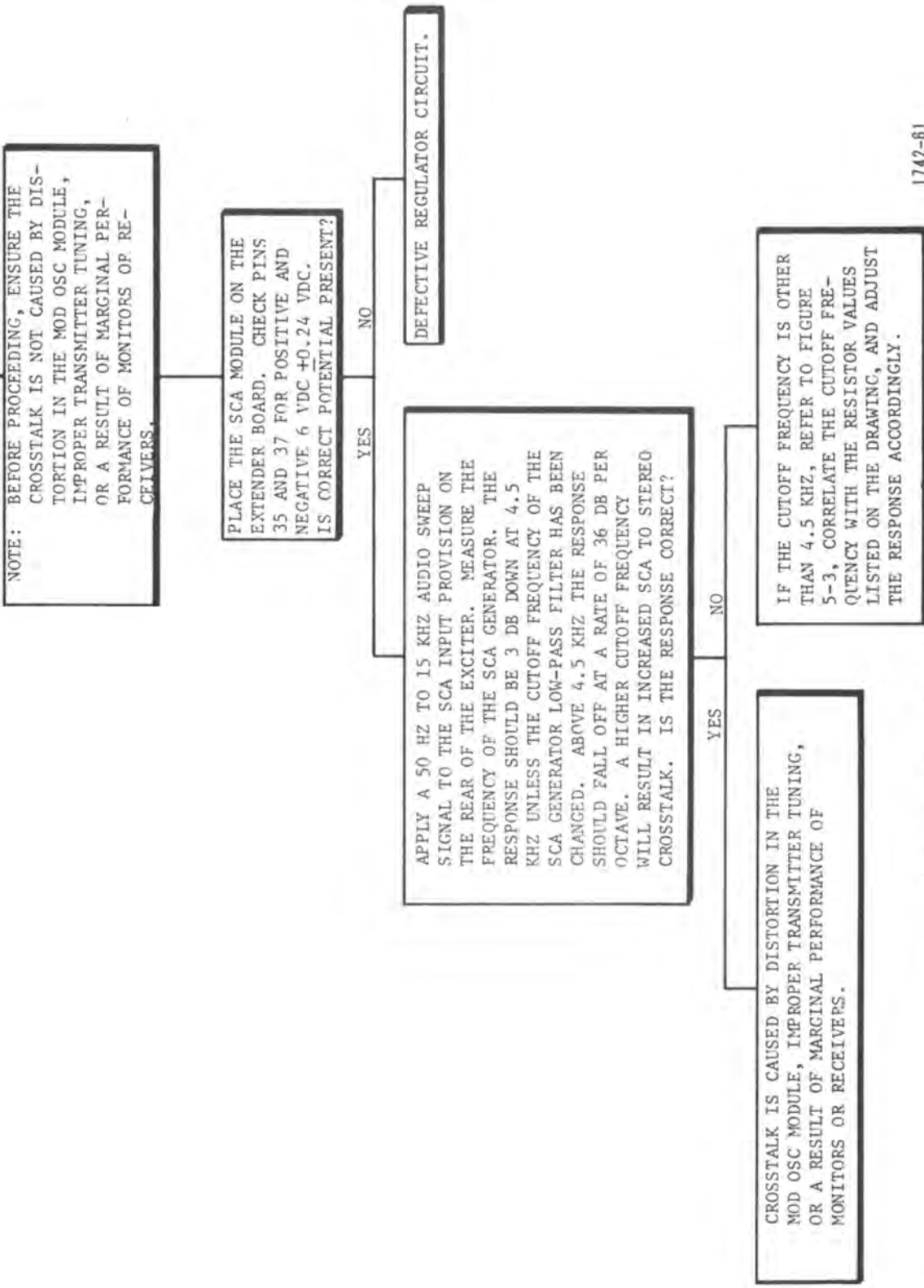

1742-61

Figure 5-8. SCA To Stereo Crosstalk

SECTION VI

PARTS LIST

6-1. GENERAL

6-2. Refer to table 6-1 for replaceable parts which are required for proper maintenance of the MS-15 SCA MODULE. Table entries are indexed by component number.

Table 6-1. SCA MODULE Front Panel - 994 7992 001

REF. SYMBOL	HARRIS PART NO.	DESCRIPTION	QTY.
-----	992 4977 001	SCA MODULE Circuit Board (Refer to table 6-2)	1

Table 6-2. SCA MODULE Circuit Board - 992 4977 001

REF. SYMBOL	HARRIS PART NO.	DESCRIPTION	QTY.
C1	500 0840 000	Capacitor, 680 pF, 300V, Mica	1
C2	500 0852 000	Capacitor, 1000 pF, 500V	1
C3	526 0049 000	Capacitor, 6.8 uF, 35V, 20%	1
C4	516 0375 000	Capacitor, 0.01 uF, 50V	1
C5	526 0049 000	Capacitor, 6.8 uF, 35V, 20%	1
C6 thru C9	516 0375 000	Capacitor, 0.01 uF, 50V	4
C10,C11	500 0756 000	Capacitor, 330 pF, 500V	2
C12	500 0754 000	Capacitor, 220 pF, 500V	1
C13	500 0830 000	Capacitor, 240 pF, 500V, Mica	1
C14,C15	500 0756 000	Capacitor, 330 pF, 500V	2
C16,C17,C18	500 0878 000	Capacitor, 1500 pF, 500V, 5%	3
C19	500 0852 000	Capacitor, 1000 pF, 500V	1
C20	516 0375 000	Capacitor, 0.01 uF, 50V	1
C21	500 0759 000	Capacitor, 100 pF, 500V	1
C22	500 0784 000	Capacitor, 330 uF, Mica	1
C23	500 0826 000	Capacitor, 120 pF, 500V	1
C24	500 0852 000	Capacitor, 1000 pF, 500V	1
C25,C26	516 0375 000	Capacitor, 0.01 uF, 50V	2
C27	500 0840 000	Capacitor, 680 pF, 300V, Mica	1
C28	500 0842 000	Capacitor, 820 pF, 300V	1
C29	500 0755 000	Capacitor, 270 pF, 500V	1
C30	500 0888 000	Capacitor, 3900 pF, 500V	1

Table 6-2. SCA MODULE Circuit Board - 992 4977 001 (Continued)

REF. SYMBOL	HARRIS PART NO.	DESCRIPTION	QTY.
C31	516 0453 000	Capacitor, 0.1 uF, 100V, 20%	1
C32	500 0759 000	Capacitor, 100 uF, 500V	1
C33	500 0821 000	Capacitor, 68 pF, 500V, Mica	1
C34	500 0759 000	Capacitor, 100 pF, 500V	1
C35	500 0809 000	Capacitor, 22 pF, 500V, Mica	1
C36	526 0049 000	Capacitor, 6.8 uF, 35V, 20%	1
C37,C38	516 0375 000	Capacitor, 0.01 uF, 50V	2
C39	526 0049 000	Capacitor, 6.8 uF, 35V, 20%	1
C40	526 0310 000	Capacitor, 0.22 uF, 35V, 20%	1
C41	526 0325 000	Capacitor, 0.1 uF, 35V, 20%	1
C42	500 0759 000	Capacitor, 100 pF, 500V	1
C43,C44	526 0049 000	Capacitor, 6.8 uF, 35V, 20%	2
C45	526 0106 000	Capacitor, 27 uF, Tant	1
C47	500 0759 000	Capacitor, 100 pF, 500V	1
C48 thru C51	526 0049 000	Capacitor, 6.8 uF, 35V, 20%	4
C52	526 0340 000	Capacitor, 1 uF, 35V, 10%	1
C53 thru C63	516 0375 000	Capacitor, 0.01 uF, 50V	11
C64,C65,C66	526 0049 000	Capacitor, 6.8 uF, 35V, 20%	3
CR1 thru CR5	384 0205 000	Diode, Silicon, 1N915	5
CR6,CR7,CR8	384 0661 000	Diode, LED, Green	3
CR9	384 0205 000	Diode, Silicon, 1N914	1
CR10	384 0664 000	Diode, LED, Yellow	1

Table 6-2. SCA MODULE Circuit Board - 992 4977 001 (Continued)

REF. SYMBOL	HARRIS PART NO.	DESCRIPTION	QTY.
CR11 thru CR13	384 0205 000	Diode, Silicon, 1N914	3
CR14	384 0662 000	Diode, LED, Red	1
CR15,CR16	384 0205 000	Diode, Silicon, 1N914	2
CR17 thru C20	384 0431 000	Diode, 1N4001	4
J1 thru J5	610 0679 000	Plug, Shorting	5
L1,L2	492 0363 000	Inductor, Variable	2
Q1	380 0126 000	Transistor, 2N4403	1
Q2,Q3	380 0319 000	Transistor, MPS A14	2
R1	540 1177 000	Resistor, 180 ohm, 1/2W, 5%	1
R2	550 0940 000	Potentiometer, 100 ohm, Bourns	1
R3	540 1160 000	Resistor, 22k ohm, 1/2W, 5%	1
R4	540 1114 000	Resistor, 4700 ohm, 1/2W, 5%	1
R5	540 1105 000	Resistor, 5100 ohm, 1/2W, 5%	1
R6	550 0928 000	Potentiometer, 20k ohm, 1/2W	1
R7	540 1111 000	Resistor, 10k ohm, 1/2W, 5%	1
R8,R9	540 1249 000	Resistor, 68k ohm, 1/2W, 5%	2
R10,R11	540 1111 000	Resistor, 10k ohm, 1/2W, 5%	2
R12	550 0927 000	Potentiometer, 2k ohm, Bourns	1
R13	540 1162 000	Resistor, 1 Megohm, 1/2W, 5%	1
R14	540 1129 000	Resistor, 1500 ohm, 1/2W, 5%	1
R15	540 1162 000	Resistor, 1 Megohm, 1/2W, 5%	1
R16	550 0927 000	Potentiometer, 2k ohm, 1/2W, 10%	1

Table 6-2. SCA MODULE Circuit Board - 992 4977 001 (Continued)

REF. SYMBOL	HARRIS PART NO.	DESCRIPTION	QTY.
R17	540 0913 000	Potentiometer, 5k ohm, 1/2W, 10%	1
R18	540 1122 000	Resistor, 47k ohm, 1/2W, 5%	1
R19	550 0913 000	Potentiometer, 5k ohm, 1/2W, 10%	1
R20	540 1172 000	Resistor, 56k ohm, 1/2W, 5%	1
R21	540 1182 000	Resistor, 2200 ohm, 1/2W, 5%	1
R22	540 1105 000	Resistor, 5.1 ohm, 1/2W, 5%	1
R23,R24	540 1110 000	Resistor, 68 ohm, 1/2W, 5%	2
R25	540 1315 000	Resistor, 1.1k ohm, 1/2W, 5%	1
R26	540 1160 000	Resistor, 22k ohm, 1/2W, 5%	1
R27	540 1210 000	Resistor, 150k ohm, 1/2W, 5%	1
R28,R29	548 0321 000	Resistor, 90.9k ohm, 1/4W, 1%	2
R30	540 1250 000	Resistor, 180k ohm, 1/2W, 5%	1
R31,R32	548 0866 000	Resistor, 56.2k ohm, 1/4W, 1%	2
R33	540 1132 000	Resistor, 110k ohm, 1/2W, 5%	1
R34,R35	548 0341 000	Resistor, 33.2k ohm, 1/4W, 1%	2
R36	540 1249 000	Resistor, 68k ohm, 1/2W, 5%	1
R37	540 1212 000	Resistor, 220k ohm, 1/2W, 5%	1
R38	550 0931 000	Potentiometer, 1 Megohm, 1/2W, 10%	1
R39	540 1162 000	Resistor, 1 Megohm, 1/2W, 5%	1
R40	540 1159 000	Resistor, 100k ohm, 1/2W, 5%	1
R41	540 1317 000	Resistor, 91k ohm, 1/2W, 5%	1

Table 6-2. SCA MODULE Circuit Board - 992 4977 001 (Continued)

REF. SYMBOL	HARRIS PART NO.	DESCRIPTION	QTY.
R42	540 1162 000	Resistor, 1 Megohm, 1/2W, 5%	1
R43	540 1102 000	Resistor, 100 ohm, 1/2W, 5%	1
R44	540 1116 000	Resistor, 1000 ohm, 1/2W, 5%	1
R45	540 1102 000	Resistor, 100 ohm, 1/2W, 5%	1
R46	540 1162 000	Resistor, 1 Megohm, 1/2W, 5%	1
R47	540 1104 000	Resistor, 2000 ohm, 1/2W, 5%	1
R48	540 1111 000	Resistor, 10k ohm, 1/2W, 5%	1
R49	540 1159 000	Resistor, 100k ohm, 1/2W, 5%	1
R50	540 1115 000	Resistor, 470 ohm, 1/2W, 5%	1
R51	540 1111 000	Resistor, 10k ohm, 1/2W, 5%	1
R52	540 1162 000	Resistor, 1 Megohm, 1/2W, 5%	1
R53	540 1105 000	Resistor, 5100 ohm, 1/2W, 5%	1
R54	550 0931 000	Potentiometer, 1 Megohm, 1/2W, 10%	1
R55	540 1122 000	Resistor, 47k ohm, 1/2W, 5%	1
R56	540 1198 000	Resistor, 470k ohm, 1/2W, 5%	1
R57	540 1159 000	Resistor, 100k ohm, 1/2W, 5%	1
R58	540 1212 000	Resistor, 220k ohm, 1/2W, 5%	1
R59	540 1181 000	Resistor, 680 ohm, 1/2W, 5%	1
R60, R61	540 1159 000	Resistor, 100k ohm, 1/2W, 5%	2
R62, R63, R64	540 1115 000	Resistor, 470 ohm, 1/2W, 5%	3
R65, R66	540 0308 000	Resistor, 100 ohm, 1W, 5%	2

Table 6-2. SCA MODULE Circuit Board - 992 4977 001 (Continued)

REF. SYMBOL	HARRIS PART NO.	DESCRIPTION	QTY.
R67 thru R72	540 1111 000	Resistor, 10k ohm, 1/2W, 5%	6
R73	540 1212 000	Resistor, 220k ohm, 1/2W, 5%	1
R74 thru R77	540 1159 000	Resistor, 100k ohm, 1/2W, 5%	4
R78	540 1115 000	Resistor, 470 ohm, 1/2W, 5%	1
R79	540 1111 000	Resistor, 10k ohm, 1/2W, 5%	1
R80	540 1153 000	Resistor, 8.2k ohm, 1/2W, 5%	1
R82	540 1115 000	Resistor, 470 ohm, 1/2W, 5%	1
R83	540 1159 000	Resistor, 100k ohm, 1/2W, 5%	1
R84	540 1182 000	Resistor, 2.2k ohm, 1/2W, 5%	1
R85	540 1183 000	Resistor, 5.6k ohm, 1/2W, 5%	1
R86	540 1183 000	Resistor, 5.6k ohm, 1/2W, 5%	1
R87 thru R90	540 1102 000	Resistor, 100 ohm, 1/2W, 5%	4
R91	540 1111 000	Resistor, 10k ohm, 1/2W, 5%	1
R92	540 1159 000	Resistor, 100k ohm, 1/2W, 5%	1
R93	540 1130 000	Resistor, 620 ohm, 1/2W, 5%	1
S1,S2,S3	604 0866 000	Switch, Pushbutton, 5PDT	3
T1	478 0315 000	Transformer, Line to Line	1
U1	382 0538 000	Integrated Circuit, XR2206CP	1
U2,U3	382 0450 000	Integrated Circuit, HA1-4741-5	2
U4	382 0288 000	Integrated Circuit, CD4011AE	1
U5	382 0396 000	Integrated Circuit, CD4012AE	1

Table 6-2. SCA MODULE Circuit Board - 992 4977 001 (Continued)

REF. SYMBOL	HARRIS PART NO.	DESCRIPTION	QTY.
U6	382 0510 000	Integrated Circuit, ILQ-74	1
U7	382 0471 000	Integrated Circuit, MC7806CT	1
U8	382 0470 000	Integrated Circuit, MC7906CT	1
U9	382 0523 000	Integrated Circuit, MC14066BCP	1
XU1	404 0675 000	Socket, Integrated Circuit, 16 Pin	1
XU2 thru XU5	404 0674 000	Socket, Integrated Circuit, 14 Pin	4
XU6	404 0675 000	Socket, Integrated Circuit, 16 Pin	1
XU9	404 0674 000	Socket, Integrated Circuit, 14 Pin	1
	943 1697 001	Printed Circuit Board	1

STEREO
DIGITAL MODULE

TECHNICAL MANUAL

STEREO DIGITAL MODULE

994 7990 001



HARRIS CORPORATION

Broadcast Products Division

T.M. No. 888 1742 004

Printed: October 1977
Revision A: February 1978
Revision B: March 1979
Revision C: April 1980
Revision E: March 1981
Revision F: June 1981

WARNING

THE CURRENTS AND VOLTAGES IN THIS EQUIPMENT ARE DANGEROUS. PERSONNEL MUST AT ALL TIMES OBSERVE SAFETY REGULATIONS.

This manual is intended as a general guide for trained and qualified personnel who are aware of the dangers inherent in handling potentially hazardous electrical/electronic circuits. It is not intended to contain a complete statement of all safety precautions which should be observed by personnel in using this or other electronic equipment.

The installation, operation, maintenance and service of this equipment involves risks both to personnel and equipment, and must be performed only by qualified personnel exercising due care. HARRIS CORPORATION shall not be responsible for injury or damage resulting from improper procedures or from the use of improperly trained or inexperienced personnel performing such tasks.

During installation and operation of this equipment, local building codes and fire protection standards must be observed. The following National Fire Protection Association (NFPA) standards are recommended as references:

- Automatic Fire Detectors, No. 72E
- Installation, Maintenance, and Use of Portable Fire Extinguishers, No. 10
- Halogenated Fire Extinguishing Agent Systems, No. 12A

WARNING

ALWAYS DISCONNECT POWER BEFORE OPENING COVERS, DOORS, ENCLOSURES, GATES, PANELS OR SHIELDS. ALWAYS USE GROUNDING STICKS AND SHORT OUT HIGH VOLTAGE POINTS BEFORE SERVICING. NEVER MAKE INTERNAL ADJUSTMENTS, PERFORM MAINTENANCE OR SERVICE WHEN ALONE OR WHEN FATIGUED.

Do not remove, short-circuit or tamper with interlock switches on access covers, doors, enclosures, gates, panels or shields. Keep away from live circuits, know your equipment and don't take chances.

WARNING

IN CASE OF EMERGENCY ENSURE THAT POWER HAS BEEN DISCONNECTED.

Treatment of Electrical Shock

1. If victim is not responsive follow the A-B-Cs of basic life support.

PLACE VICTIM FLAT ON HIS BACK ON A HARD SURFACE

A AIRWAY

IF UNCONSCIOUS,
OPEN AIRWAY

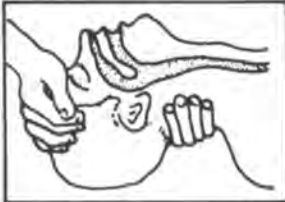

LIFT UP NECK
PUSH FOREHEAD BACK
CLEAR OUT MOUTH IF NECESSARY
OBSERVE FOR BREATHING

B BREATHING

IF NOT BREATHING,
BEGIN ARTIFICIAL
BREATHING



TILT HEAD
PINCH NOSTRILS
MAKE AIRTIGHT SEAL

4 QUICK FULL BREATHS

REMEMBER MOUTH TO MOUTH RESUSCITATION
MUST BE COMMENCED AS SOON AS POSSIBLE

CHECK CAROTID PULSE



IF PULSE ABSENT,
BEGIN ARTIFICIAL
CIRCULATION

C CIRCULATION

DEPRESS STERNUM 1 1/2" TO 2"

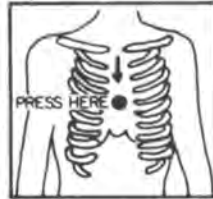

APPROX. { ONE RESCUER
80 SEC. { 15 COMPRESSIONS
2 QUICK BREATHS

APPROX. { TWO RESCUERS
60 SEC. { 5 COMPRESSIONS
1 BREATH



NOTE: DO NOT INTERRUPT RHYTHM OF COMPRESSIONS
WHEN SECOND PERSON IS GIVING BREATH

Call for medical assistance as soon as possible.

2. If victim is responsive.
 - a. keep them warm
 - b. keep them as quiet as possible
 - c. loosen their clothing
(a reclining position is recommended)

FIRST-AID

Personnel engaged in the installation, operation, maintenance or servicing of this equipment are urged to become familiar with first-aid theory and practices. The following information is not intended to be complete first-aid procedures, it is brief and is only to be used as a reference. It is the duty of all personnel using the equipment to be prepared to give adequate Emergency First Aid and thereby prevent avoidable loss of life.

Treatment of Electrical Burns

1. Extensive burned and broken skin
 - a. Cover area with clean sheet or cloth. (Cleanest available cloth article.)
 - b. Do not break blisters, remove tissue, remove adhered particles of clothing, or apply any salve or ointment.
 - c. Treat victim for shock as required.
 - d. Arrange transportation to a hospital as quickly as possible.
 - e. If arms or legs are affected keep them elevated.

NOTE

If medical help will not be available within an hour and the victim is conscious and not vomiting, give him a weak solution of salt and soda: 1 level teaspoonful of salt and 1/2 level teaspoonful of baking soda to each quart of water (neither hot or cold). Allow victim to sip slowly about 4 ounces (a half of glass) over a period of 15 minutes. Discontinue fluid if vomiting occurs. (Do not give alcohol.)

2. Less severe burns - (1st & 2nd degree)
 - a. Apply cool (not ice cold) compresses using the cleanest available cloth article.
 - b. Do not break blisters, remove tissue, remove adhered particles of clothing, or apply salve or ointment.
 - c. Apply clean dry dressing if necessary.
 - d. Treat victim for shock as required.
 - e. Arrange transportation to a hospital as quickly as possible.
 - f. If arms or legs are affected keep them elevated.

REFERENCE: ILLINOIS HEART ASSOCIATION

AMERICAN RED CROSS STANDARD FIRST AID AND PERSONAL SAFETY MANUAL
(SECOND EDITION)

TABLE OF CONTENTS

<u>Paragraph</u>		<u>Page</u>
SECTION I. GENERAL DESCRIPTION		
1-1.	Equipment Purpose	1
1-3.	Technical Characteristics	1
SECTION II. INSTALLATION		
2-1.	General	1
SECTION III. CONTROLS AND INDICATORS		
3-1.	General	1
SECTION IV. PRINCIPLES OF OPERATION		
4-1.	Circuit Description	9
4-2.	Signal Generation	9
4-3.	Oscillator	9
4-4.	Frequency Divider Chain	9
4-6.	Switching Signals	9
4-7.	Pilot Signal	9
4-8.	Pilot Phase Control	10
4-9.	Control Circuits	10
4-10.	Mode Selection	10
4-13.	SCA-2 Interlock	10
4-14.	Power Up Mode Selection	14
4-15.	Remote Control	14
4-16.	Power	14
SECTION V. MAINTENANCE		
5-1.	Corrective Maintenance	14
5-3.	Troubleshooting	14
SECTION VI. PARTS LIST		
6-1.	General	27

LIST OF TABLES

<u>Table</u>	<u>Page</u>
1-1. Technical Characteristics	2
3-1. STEREO DIGITAL MODULE Controls and Indicators	4
3-2. Control Adjustments	6
5-1. STEREO DIGITAL MODULE Fault Isolation Index	16
5-2. STEREO DIGITAL MOUDLE Parts Index	18
6-1. STEREO DIGITAL MODULE Front Panel	28
6-2. STEREO DIGITAL MODULE Circuit Board	29

LIST OF ILLUSTRATIONS

<u>Figure</u>	<u>Page</u>
3-1. STEREO DIGITAL MODULE	3
3-2. Composite Waveforms	7
4-1. STEREO DIGITAL MODULE Block Diagram	11
4-2. Frequency Divider Chain Waveforms	13
5-1. STEREO DIGITAL MODULE Parts Layout	17
5-2. STEREO DIGITAL MODULE Waveforms	20
5-3. STEREO DIGITAL MODULE Schematic	21
5-4. No Pilot	23
5-5. Pilot Out of Phase	24
5-6. No Stereo Switching Signal Output	25
5-7. Local and Remote Mode Selection Inoperative (Any Mode)	26

SECTION I

GENERAL DESCRIPTION

1-1. EQUIPMENT PURPOSE

1-2. The STEREO DIGITAL MODULE generates the 38 kHz and 114 kHz stereophonic switching signals, the phase controlled 19 kHz pilot signal, and the stereophonic/monaural mode switching signals. The module also allows power up mode selection of any stereophonic or monaural mode, prevents simultaneous stereophonic and 41 kHz SCA operation, and interfaces with remote control of mode selection.

1-3. TECHNICAL CHARACTERISTICS

1-4. Table 1-1 lists operating characteristics and parameters of the MS-15 STEREO DIGITAL MODULE.

SECTION II

INSTALLATION

2-1. GENERAL

2-2. Refer to 888 1742 001, MS-15 Exciter, Section II, Installation.

SECTION III

CONTROLS AND INDICATORS

3-1. GENERAL

3-2. Figure 3-1 shows the location of each control or indicator associated with the MS-15 STEREO DIGITAL MODULE and table 3-1 lists the controls and indicators with a description of each item listed. Control setup adjustments are listed in table 3-2.

Table 1-1. Technical Characteristics

FUNCTION	CHARACTERISTIC
<u>INPUTS</u>	
POWER:	+6 Vdc @ 0.025 amperes. -6 Vdc @ 0.022 amperes.
CONTROL:	
Remote Switching	+18V to +24 Vdc Momentary Level.
SCA-2 Inhibit	+6 Vdc for Stereo Inhibit. -6 or 0 Vdc for Stereo Operate.
<u>OUTPUTS</u>	
SIGNAL:	
Pilot	1.7V p-p Sinusodial 19 kHz Pilot.
CONTROL:	
Stereo Switching	+12V p-p 38 kHz Square Wave -12V p-p 38 kHz Square Wave +12V p-p 114 kHz Square Wave -12V p-p 114 kHz Square Wave
Mode Switching	+6 Vdc for selected mode -6 Vdc for inhibit

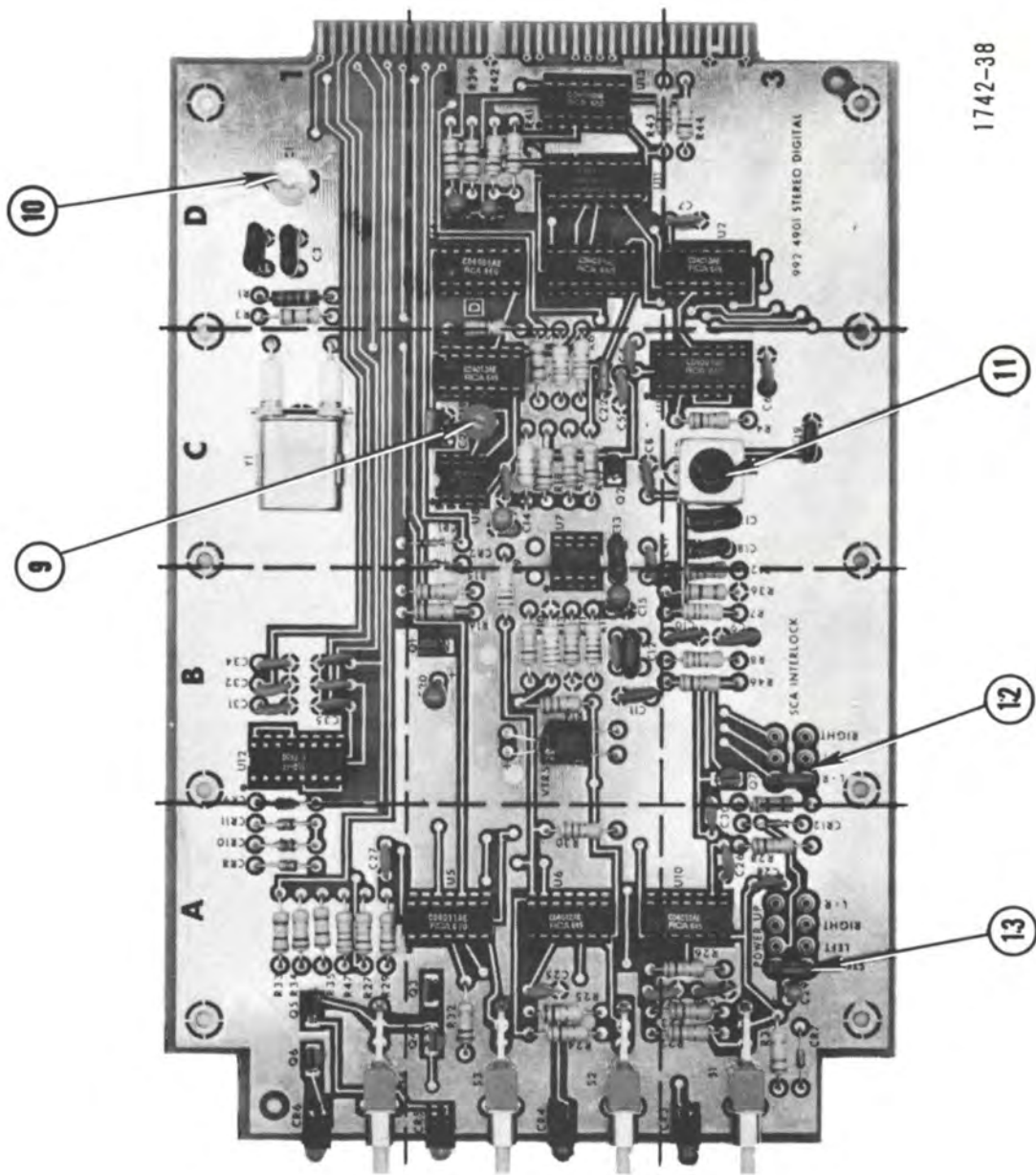

1742-38

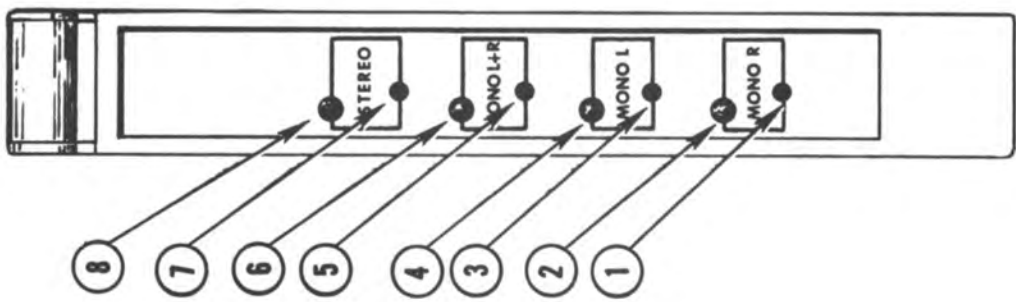

Figure 3-1. STEREO DIGITAL MODULE

Table 3-1. STEREO DIGITAL MODULE Controls and Indicators

REF.	CONTROL/INDICATOR	FUNCTION
1	MONO R Switch (S1)	Enables the mono R mode to transmit a mono signal from the right stereo channel and mute the left stereo channel.
2	MONO R Indicator (CR3)	Indicates the mono R mode of operation is enabled when illuminated.
3	MONO L Switch (S2)	Enables mono L mode to transmit a mono signal from the left stereo channel and mute the right stereo channel.
4	MONO L Indicator (CR4)	Indicates mono L mode of operation is enabled when illuminated.
5	MONO L+R Switch (S3)	Enables the mono L+R mode to transmit a mono signal from both stereo channels.
6	MONO L+R Indicator (CR5)	Indicates mono L+R mode of operation is enabled when illuminated.
7	STEREO Switch (S4)	Enables stereo mode operation.
8	STEREO Indicator (CR6)	Indicates stereo mode of operation is enabled when illuminated.
9	AUTOMATIC PHASE CONTROL OFFSET Adjustment (R19)	Adjusts phase comparator U8 voltage off-set to zero.
10	PILOT FREQUENCY Control (C1)	Adjusts frequency of pilot signal.
11	PILOT FILTER Adjustment (L1)	Tunes pilot low-pass filter.
12	SCA INTERLOCK L+R/ LEFT/RIGHT Program Jumper (J2)	Selects monaural mode STEREO DIGITAL module will enter if simultaneous 41 kHz SCA and stereophonic operation is attempted. (Factory set for L+R mono.)

Table 3-1. STEREO DIGITAL MODULE Controls and Indicators (Continued)

REF.	CONTROL/INDICATOR	FUNCTION
13	POWER UP STEREO/LEFT RIGHT/L+R Program Jumper (J1)	Selects the mode in which the module will initialize when power is applied. (Factory set for stereo.)

Table 3-2. Control Adjustments

CONTROL	ADJUSTMENT
<p>AUTOMATIC PHASE CONTROL OFFSET Adjustment (R19)</p>	<ol style="list-style-type: none"> 1. Remove the module from the exciter and mount the module in the exciter using the extender board provided with the unit. 2. Disconnect the stereo audio inputs from the LEFT FRONT + and - (TBl pins 1 and 3) and the RIGHT FRONT + and - (TBl pins 4 and 6). 3. Connect a 50 Hz sinewave to the LEFT FRONT + and - (TBl pins 1 and 3). For test purposes only, cross connect the left and right exciter stereo audio inputs out of phase so that L-R as follows: <ul style="list-style-type: none"> <li style="text-align: center;">TBl pin 1 to TBl pin 6 <li style="text-align: center;">TBl pin 3 to TBl pin 4 4. Depress the LEFT MODULATION meter switch. Adjust the 50 Hz signal level until the MODULATION meter indicates 100%. <p style="text-align: center;">NOTE</p> <p style="text-align: center;">Correct adjustment of R19 requires use of an oscilloscope and X1 probe which are flat in phase and amplitude from dc to 38 kHz. There must be no oscilloscope distortion when the vertical display is expanded.</p> 5. Connect the oscilloscope to module pin 70. Synchronize the oscilloscope to the LEFT FRONT audio.

Table 3-2. Control Adjustments (Continued)

CONTROL	ADJUSTMENT
	<p>6. Expand the vertical display until the zero crossing can be observed in detail. Adjust R19 until the pilot pinchoff points line up as shown in figure 3-2.</p> <p>7. Disconnect the oscilloscope from the module. Remove the module and extender board and replace the module in the exciter.</p> <p>8. Remove the 50 Hz test signal and reconnect the stereo audio inputs.</p> <div data-bbox="833 940 1417 1709" style="text-align: center;"> </div> <p>1742-69</p>

Figure 3-2. Composite Waveform

Table 3-2. Control Adjustments (Continued)

CONTROL	ADJUSTMENT
<p>PILOT FREQUENCY Control (C1)</p>	<ol style="list-style-type: none"> 1. Remove the module. Mount the module in the exciter using extender board provided. 2. Connect a frequency counter to pin 67. 3. Adjust C1 to obtain an indication of 19 kHz \pm 1 Hz. 4. Disconnect the frequency counter, remove the module and extender board, and replace the module.
<p>PILOT FILTER Adjustment (L1)</p>	<ol style="list-style-type: none"> 1. Remove the module. Mount the module in the exciter using the extender board provided. 2. Connect an oscilloscope to module pin 67. 3. Adjust L1 to obtain a 1.7V P-P voltage peak. 4. Disconnect the oscilloscope, remove the module and extender board, and replace the module.

SECTION IV

PRINCIPLES OF OPERATION

4-1. CIRCUIT DESCRIPTION

4-2. SIGNAL GENERATION

4-3. **OSCILLATOR.** A CMOS gate (U4A) used as a crystal oscillator generates a stable 456 kHz reference frequency which is used to produce the 114 kHz and 38 kHz sampling signals and the 19 kHz pilot (see figure 4-1). The PILOT FREQUENCY control (C1) provides an oscillator frequency adjustment and a test point (pin 15) assists in oscillator frequency measurements. A divide-by-two counter (U1A) following the oscillator acts as a buffer and ensures symmetry of the 228 kHz clock pulse.

4-4. **FREQUENCY DIVIDER CHAIN.** The frequency divider chain divides the input clock frequency from the oscillator buffer into the 114 kHz and 38 kHz stereophonic switching signals and the 19 kHz pilot. The synchronous nature of the counter ensures coincident output transitions and uniform phase relationships among the output signals.

4-5. All flip-flops in the frequency divider chain are clocked by the 228 kHz signal from U1A. Flip-flop U2A divides the 228 kHz clock by two to produce the 114 kHz switching signal (refer to figure 4-2). Flip-flops U1B and U2B form a divide-by-three counter which outputs a 76 kHz signal. The 76 kHz signal and the 114 kHz signal from U2A are input to gates U4B and U4D which comprise a divide-by-six counter with U3B and outputs the 38 kHz switching signal. The 76 kHz signal and the 38 kHz signal from U3B are applied to a divide-by-two counter consisting of U4C and U3A which outputs the 19 kHz pilot frequency. The three signals are simultaneously clocked out of the divider chain by latch U11 which ensures synchronous output, independent of minor differences in IC manufacture.

4-6. **SWITCHING SIGNALS.** Two 38 kHz and 114 kHz outputs, each output 180 degrees out of phase are obtained from the frequency divider chain. The signals are applied to the STEREO ANALOG module through the transmission gates in U13 which enables the output whenever the output control gate (U5D) outputs a HIGH condition. The switching signals control the generation of the composite stereophonic signal.

4-7. **PILOT SIGNAL.** The pilot signal is generated by a phase-controlled closed loop which is referenced to the 19 kHz output of U11 in the frequency divider chain. Two 19 kHz outputs from the frequency divider chain, each signal 180 degrees out of phase, are differentially applied to two RC low-pass filters. Outputs from the RC low-pass filters are obtained across capacitor C12 and the light dependent resistor VTR5. The two outputs are summed at the input to the pilot buffer amplifier (U7) and produce a constant voltage with the phase shift variable from 0 to 180 degrees, dependent upon the resistance of VTR5. Amplifier U7 buffers the phase shifted signal and drives the low-pass filter which ensures that the output of the module

will be pure sine wave. The PILOT FILTER control (L1) provides an adjustment to peak the low-pass filter. The pilot signal is applied to the STEREO ANALOG module for addition into the composite stereophonic signal.

4-8. Pilot Phase Control. The pilot output signal is sampled by comparator U8 which senses zero voltage crossings of the 19 kHz pilot signal and generates a square wave of the same phase. The output of U8 drives transistor Q2 as a buffer which provides a fast rising edge to trigger phase detector U9. The dc voltage offset of U8 is adjusted to zero by the AUTOMATIC PHASE CONTROL OFFSET (R19). As long as the phase of the regenerated square wave from Q2 and the frequency reference from U11 coincide exactly, the circuit is considered correctly phased. If the phase of the pilot lags the reference signal, CR2 will conduct. If the pilot phase leads the reference signal, CR1 will conduct. Any discrepancy in pilot phase will cause pulses from the diodes to charge or discharge capacitor C20. The voltage on C20 is buffered by Q1 and acts as the control voltage for light dependent resistor VTR5. This charge determines the current through VTR5 and controls the phase shift at U7. The correction will continue until the phase of the pilot matches the phase reference to U9. Test points are provided at the output of buffer Q2, the output of diodes CR1 and CR2, and at the output of driver Q1.

4-9. CONTROL CIRCUITS

4-10. MODE SELECTION. Stereophonic/monaural mode selection and latching is performed by three dc flip flops. The dc flip flops are implemented by pairs of cross-coupled NAND gates which are controlled by levels rather than transitions. When a mode is selected, either by depressing a mode switch or by applying an input on the selected remote control input, a momentary LOW (-6 Vdc) sets the associated flip flop and resets the remaining flip flops. When all flip flops are reset, the module will enter the stereophonic mode.

4-11. Depressing switch S1 will set the MONO R flip flop (U5B and U6A), depressing switch S2 will set the MONO L flip flop (U5A and U10B), and depressing switch S3 will set the MONO L+R flip flop (U5C and U6B). As each pair of flip flop is set for a particular function, the remaining flip flops are reset. As each mode is selected, the corresponding indicator on the module front panel will illuminate and the respective mode selection line to the STEREO ANALOG module will be driven HIGH.

4-12. Depressing switch S4 (STEREO) resets all flip flops and enables the stereophonic mode. This condition causes the stereo control gate (U10A) to output a LOW condition and enable the frequency divider chain. The signal also causes the output control gate (U5D) to output a HIGH and enable the switching signal output, activate the stereo mode selection line and illuminate the STEREO indicator (CR6) through driver Q6.

4-13. SCA-2 INTERLOCK. Operation of the 41 kHz SCA channel (SCA-2) during stereophonic programming is not possible as the stereo difference channel occupies the same frequencies. If operation of the SCA-2 module (41 kHz) is attempted during stereophonic broadcast, a positive six volt dc potential from the SCA-2 module through driver Q7 will cause the module to enter the

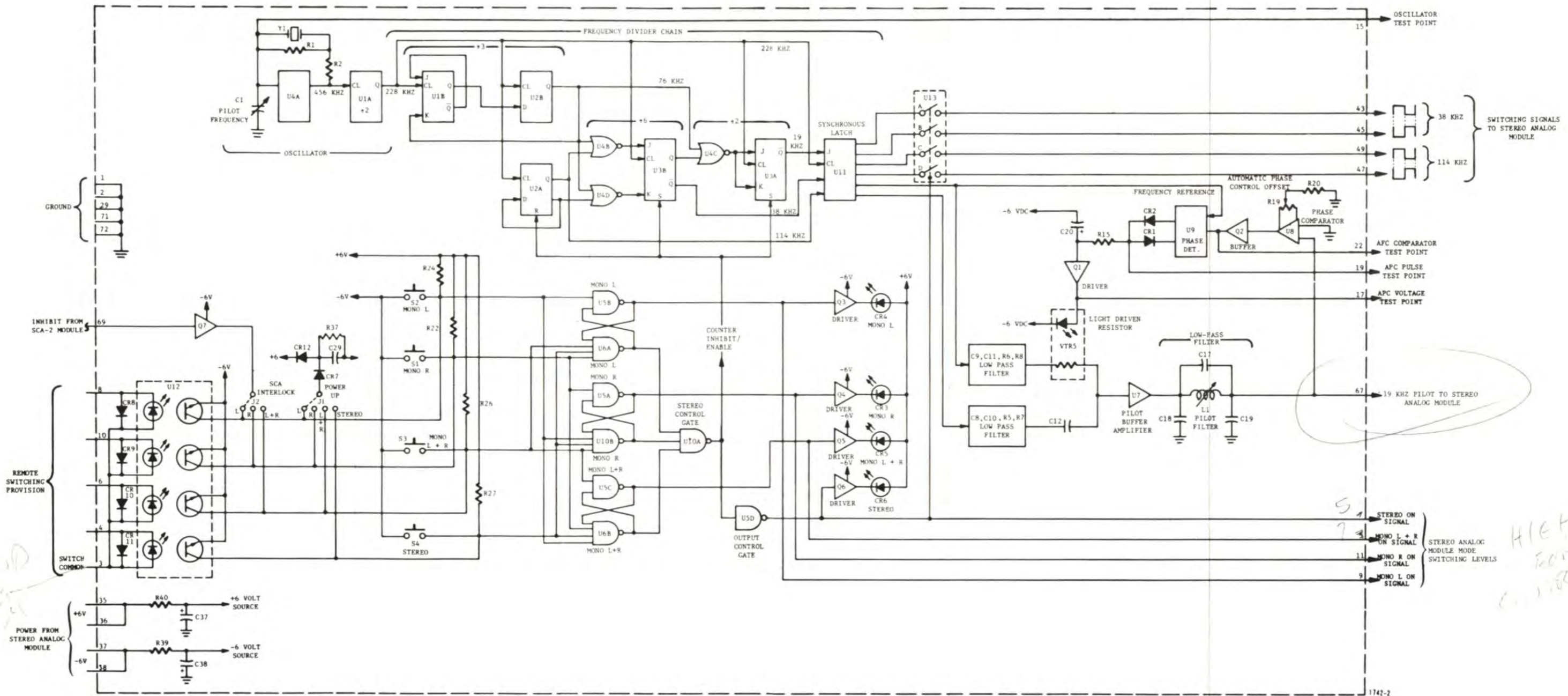
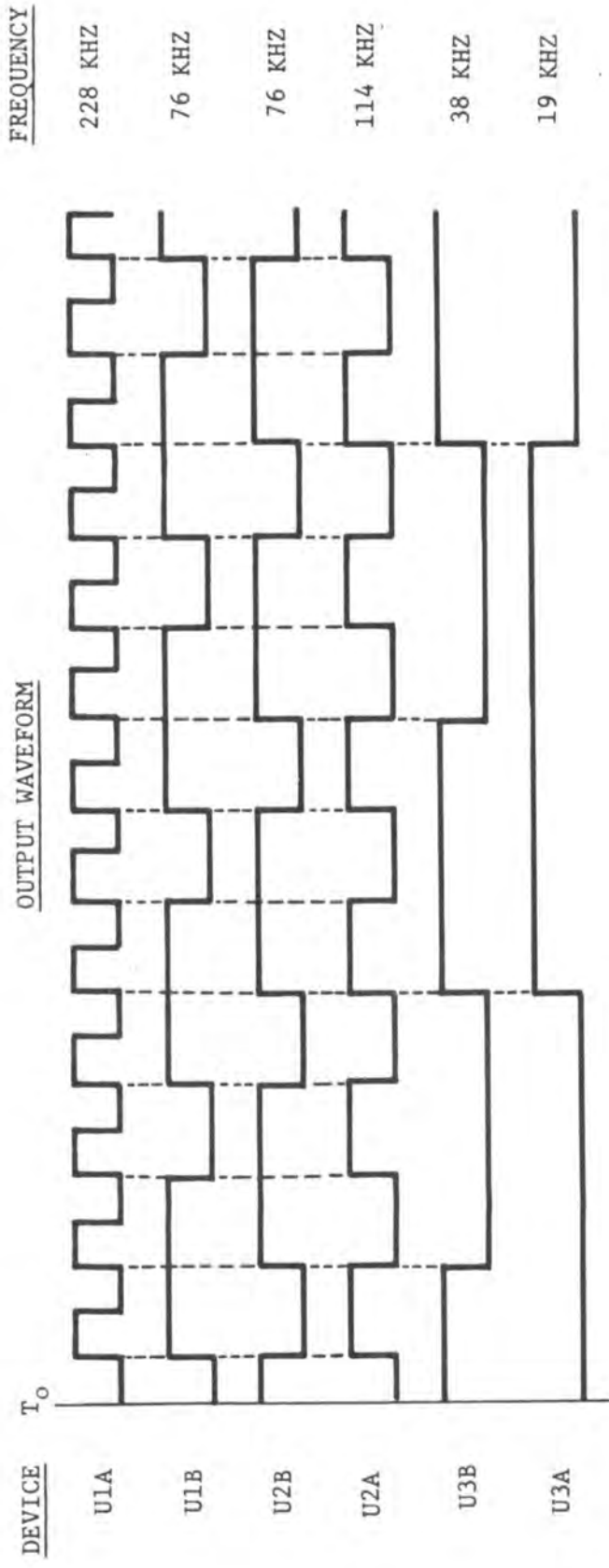

FIGURE 4-1. STEREO DIGITAL MODULE BLOCK DIAGRAM

If You Didn't Get This From My Site,
Then It Was Stolen From...
www.SteamPoweredRadio.Com



1742-30

Figure 4-2. Frequency Divider Chain Waveforms

monaural mode programmed by the SCA INTERLOCK jumper (J2). Operation of the mode selection circuit is inhibited until operation of the SCA-2 channel ceases at which time the STEREO DIGITAL module may be manually switched to the desired monaural or stereophonic mode.

4-14. POWER UP MODE SELECTION. When power is applied, capacitor C29 is discharged. Until the capacitor fully charges through diode CR12, a LOW condition will exist on the mode selection line determined by the position of POWER UP jumper J1. This will initialize the equipment in the selected mode at power application. Resistor R37 acts as a bleeder to ensure capacitor C29 discharges when power is removed.

4-15. REMOTE CONTROL. Remote control mode selection is provided by optical isolator U12. The input side of the optical isolator is protected from reverse bias by diodes CR8, CR9, CR10, and CR11. Current limiting resistors for each remote control input are located on the RFI filter. Remote control mode selection consists of application of a positive 18 to 24 Vdc potential on the particular input line.

4-16. POWER

4-17. DC power is obtained from regulators on the STEREO ANALOG module. Positive six volts dc enters the module on pins 35 and 36 and negative six volts dc enters the module on pins 37 and 38.

SECTION V

MAINTENANCE

5-1. CORRECTIVE MAINTENANCE

5-2. The MS-15 FM Exciter module maintenance philosophy consists of problem isolation to a specific area or individual component and subsequent isolation and replacement of the defective component.

5-3. TROUBLESHOOTING

5-4. In event of problems, the trouble area must first be isolated to a specific area. Most troubleshooting consists of visual checks. The MODULATION meter, MULTIMETER, fuse F1, circuit breaker CB1, and the indicators on each module should be used to determine in which area the malfunction exists. All module power supplies are equipped with LEDs which indicate the module power supply status. A single dark LED would indicate a problem associated with an individual module monolithic voltage regulator. A consistent pattern of dark LEDs however, would indicate an exciter dc distribution bus fault.

5-5. Once the trouble is isolated to a specific area, refer to the theory section of this manual for circuit discussion to aid in problem resolution. Table 5-2 lists typical trouble symptoms pertaining to the individual module operation with references to fault isolation diagrams listing probable causes

and corrective actions. A corrective action given for a trouble symptom is not necessarily the only answer to a problem. It only tends to lead the repairman into the area that may be causing the trouble. An extender board (HARRIS PN 992 4989 001) is provided with the exciter to assist in troubleshooting. In event parts are required, refer to Section VI, Parts List. The following information is contained in this section as an aid to maintenance.

<u>REFERENCE</u>	<u>TITLE</u>	<u>NUMBER</u>
Figure 5-1	STEREO DIGITAL Parts Layout	--- ---- ---
Table 5-2	STEREO DIGITAL Parts Index	--- ---- ---
Figure 5-2	STEREO DIGITAL Waveforms	--- ---- ---
Figure 5-3	STEREO DIGITAL Schematic	852 8407 001

Table 5-1. STEREO DIGITAL MODULE Fault Isolation Index

SYMPTOM	DEFECT/REFERENCE
NO PILOT	Figure 5-4
PILOT OUT OF PHASE	Figure 5-5
NO STEREO SWITCHING SIGNAL OUTPUT	Figure 5-6
LOCAL AND REMOTE MODE SELECTION INOPERATIVE (any mode).	Figure 5-7
REMOTE MODE SELECTION INOPERATIVE (any mode)	Defective U12

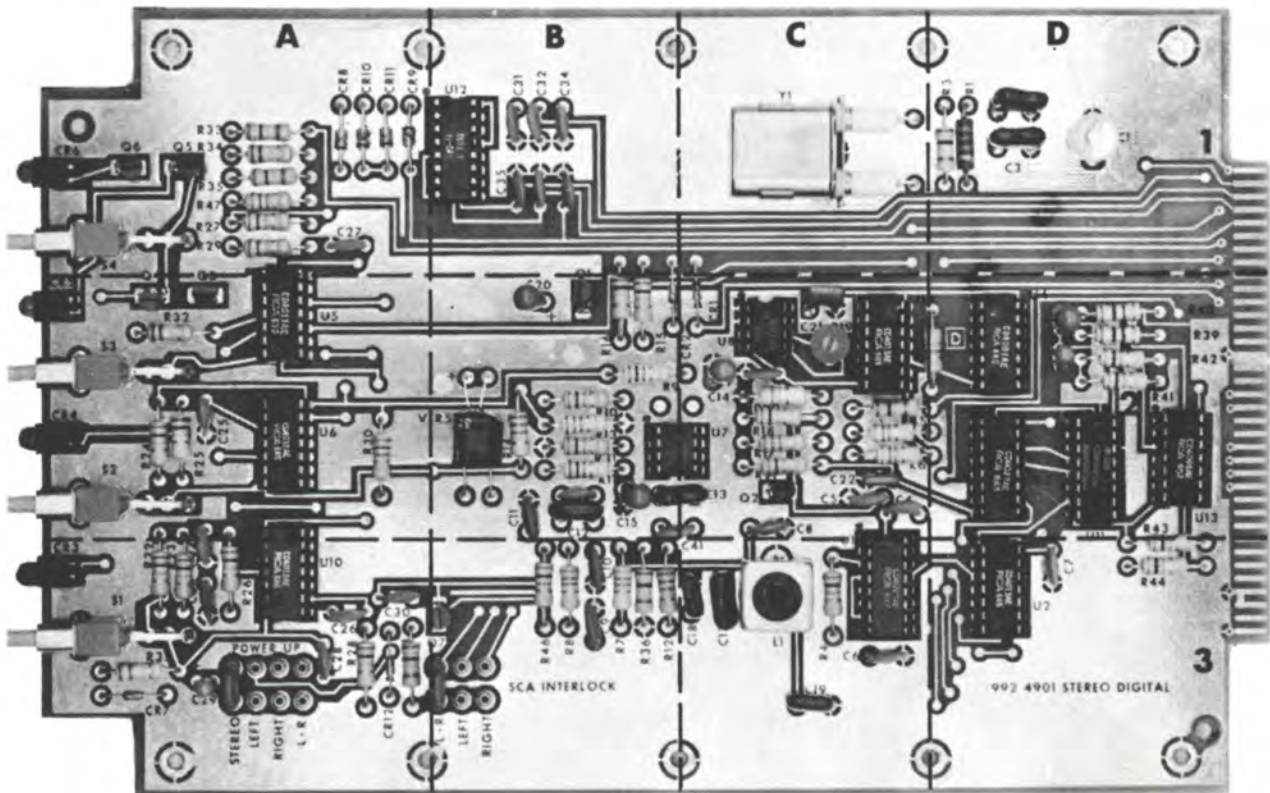

1742-39

Figure 5-1. STEREO DIGITAL MODULE Parts Layout

Table 5-2. STEREO DIGITAL MODULE Parts Index

SYMBOL	LOCATION	SYMBOL	LOCATION	SYMBOL	LOCATION	SYMBOL	LOCATION	SYMBOL	LOCATION
C1	D1	C29	A3	CR10	A1	R1	D1		
C2	D1	C30	A3	CR11	A1	R2	C2		
C3	D1	C31	B1	CR12	A3	R3	D1		
C4	C2	C32	B1			R4	C3		
C5	C2	C33	B1			R5	C2		
C6	C3	C34	B1			R6	C2		
C7	D3	C35	B1			R7	B3		
C8	C2	C36	B1			R8	B3		
C9	B3	C37	D2	VTR5	B2	R9	B2		
C10	B3	C38	D2			R10	B2		
C11	B2	C39	--			R11	B2		
C12	B2	C40	C2	J1	A3	R12	B3		
C13	C2	C41	C3	J2	B3	R13	B2		
C14	C2					R14	B2		
C15	B2			L1	C3	R15	B2		
C16	B2					R16	B2		
C17	C3					R17	C2		
C18	C3					R18	C2		
C19	C3			Q1	B2	R19	C2		
C20	B2	CR1	C2	Q2	C2	R20	C2		
C21	C2	CR2	C2	Q3	A2	R21	C2		
C22	C2	CR3	A3	Q4	A2	R22	A3		
C23	A3	CR4	A2	Q5	A1	R23	A3		
C24	A3	CR5	A2	Q6	A1	R24	A2		
C25	A2	CR6	A1	Q7	B3	R25	A2		
C26	A3	CR7	A3			R26	A3		
C27	A1	CR8	A1			R27	--		
C28	A3	CR9	A1			R28	A3		

Table 5-2. STEREO DIGITAL MODULE Parts Index (Continued)

SYMBOL	LOCATION	SYMBOL	LOCATION	SYMBOL	LOCATION	SYMBOL	LOCATION
R29	A1	S1	A3				
R30	A2	S2	A2				
R31	B2	S3	A2				
R32	A2	S4	A1				
R33	A1						
R34	A1						
R35	A1	U1	C3				
R36	B3	U2	D3				
R37	A3	U3	D2				
R38	A3	U4	D2				
R39	D2	U5	A2				
R40	D2	U6	A2				
R41	D2	U7	C2				
R42	D2	U8	C2				
R43	D3	U9	C2				
R44	D3	U10	A3				
R45	C2	U11	D2				
R46	B3	U12	B1				
R47	A1	U13	D2				
		Y1	C1				



TEST REQUIREMENTS: A. Depress the STEREO switch.

- 1A Frequency divider chain at U1 pin 3 (456 kHz).
- 1B Frequency divider chain at U1 pin 1 (228 kHz).
- 1C Frequency divider chain at U2 pin 1 (114 kHz).
- 1D Frequency divider chain at U1 pin 15 (76 kHz).

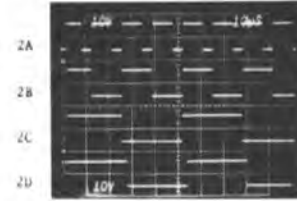

TEST REQUIREMENTS: A. Depress the STEREO switch.

- 2A Frequency divider chain at U2 pin 13 (76 kHz).
- 2B Frequency divider chain at U3 pin 15 (38 kHz).
- 2C Frequency divider chain at U3 pin 2 (19 kHz).
- 2D Frequency divider chain at U11 pin 11 (19 kHz).

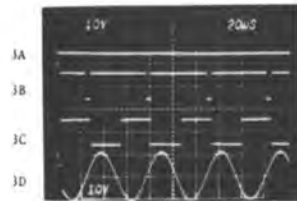

TEST REQUIREMENTS: A. Depress the STEREO switch.

- 3A Pilot phase control with pilot phase leading at U9 pin 2.
- 3B Pilot phase control with pilot phase leading at U9 pin 13.
- 3C Pilot reference with pilot phase leading at U11 pin 11.
- 3D Pilot output with pilot phase leading at module pin 67.

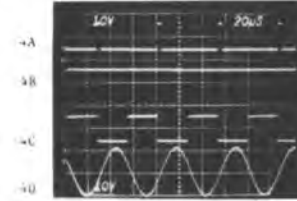

TEST REQUIREMENTS: A. Depress the STEREO switch.

- 4A Pilot phase control with pilot phase lagging at U9 pin 2.
- 4B Pilot phase control with pilot phase lagging at U9 pin 13.
- 4C Pilot reference with pilot phase lagging at U11 pin 11.
- 4D Pilot output with pilot phase lagging at module pin 67.

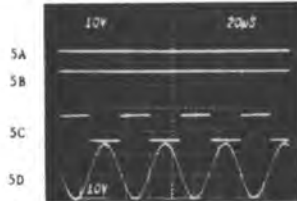

TEST REQUIREMENTS: A. Depress the STEREO switch.

- 5A Pilot phase control with pilot phase correct at U9 pin 2.
- 5B Pilot phase control with pilot phase correct at U9 pin 13.
- 5C Pilot reference with pilot phase correct at U11 pin 11.
- 5D Pilot output with pilot phase correct at module pin 67.

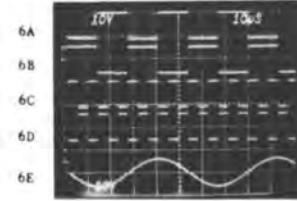

TEST REQUIREMENTS: A. Depress the STEREO switch.

- 6A 38 kHz output at module pin 43.
- 6B Inverted 38 kHz output at module pin 45.
- 6C 114 kHz output at module pin 47.
- 6D Inverted 114 kHz output at module pin 49.
- 6E 19 kHz pilot output at module pin 67.

1742-75

Figure 5-2. STEREO DIGITAL MODULE Waveforms

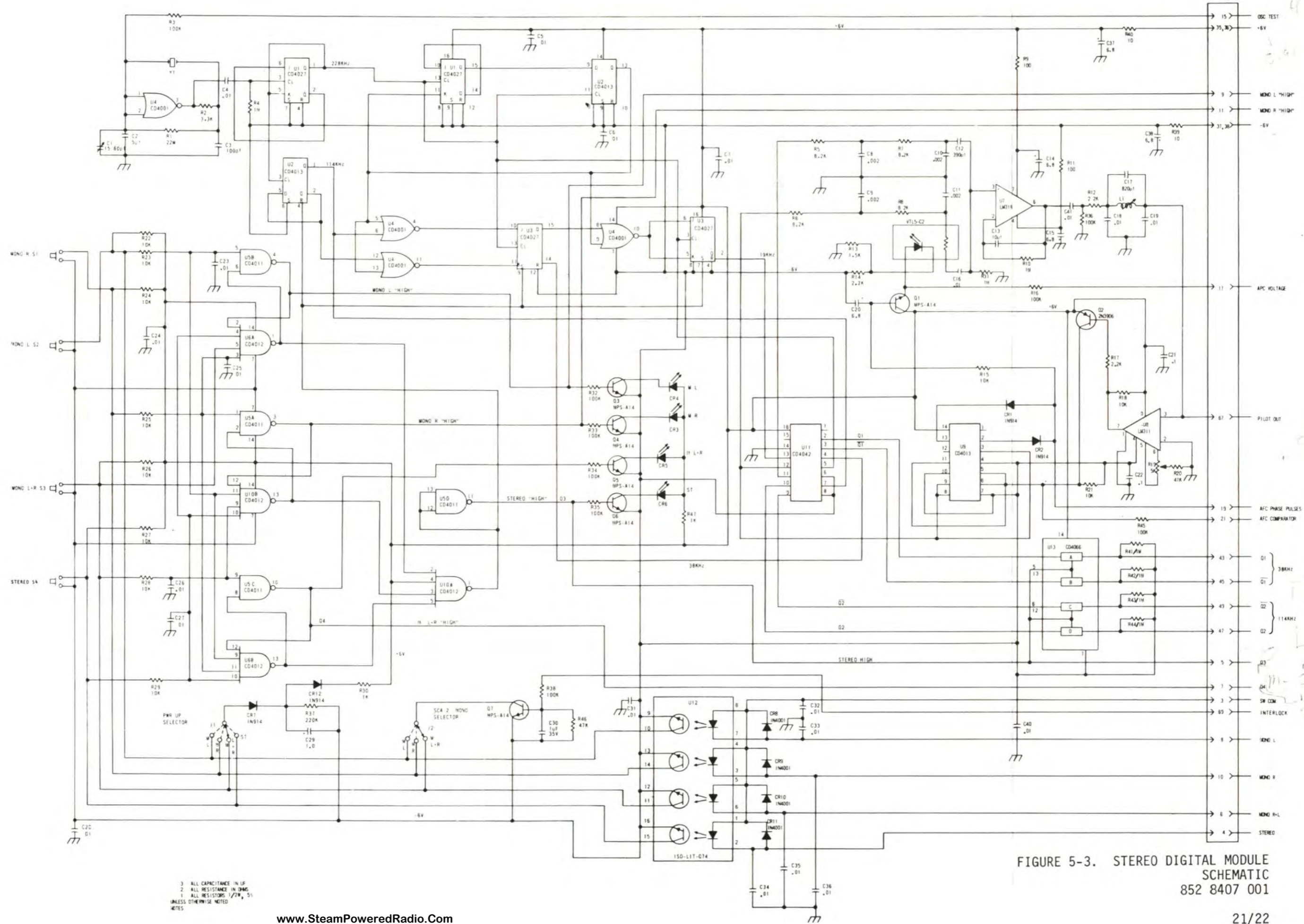

3 ALL CAPACITANCE IN μ F
 2 ALL RESISTANCE IN Ω M
 1 ALL RESISTORS 1/2W, 5%
 UNLESS OTHERWISE NOTED
 NOTES

FIGURE 5-3. STEREO DIGITAL MODULE SCHEMATIC 852 8407 001

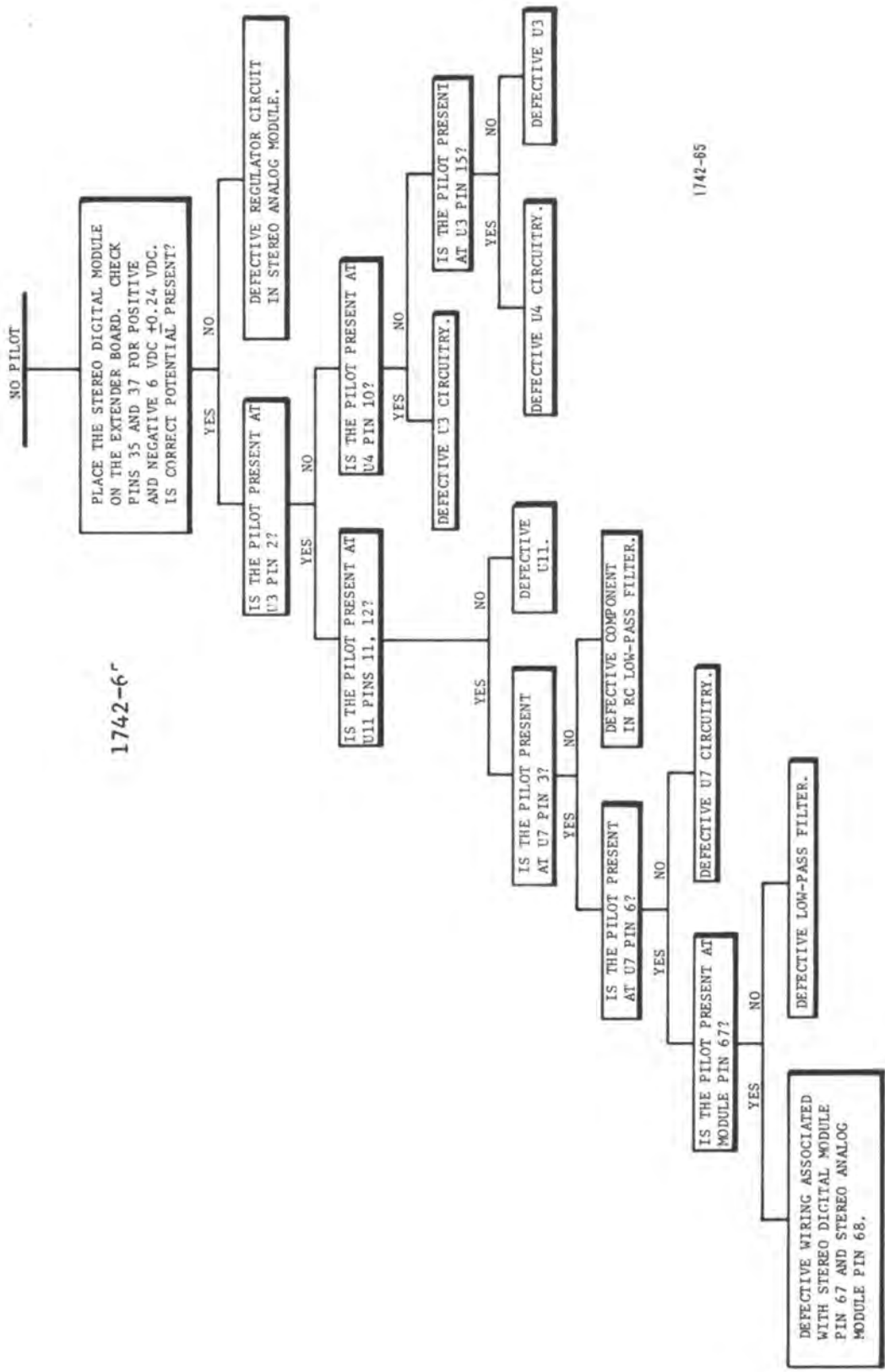

1742-6r

1742-65

Figure 5-4. No Pilot

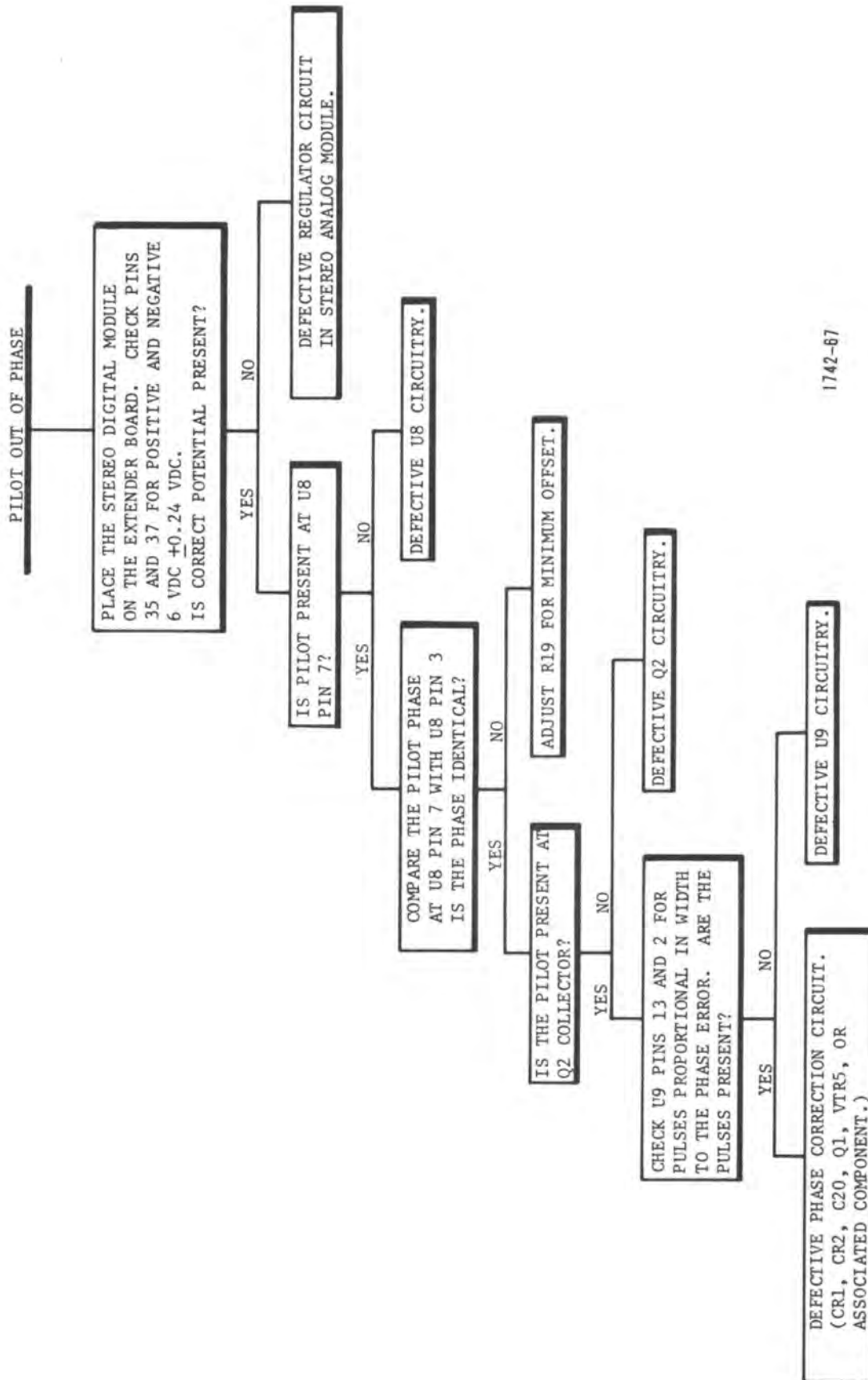

1742-87

Figure 5-5. Pilot Out of Phase

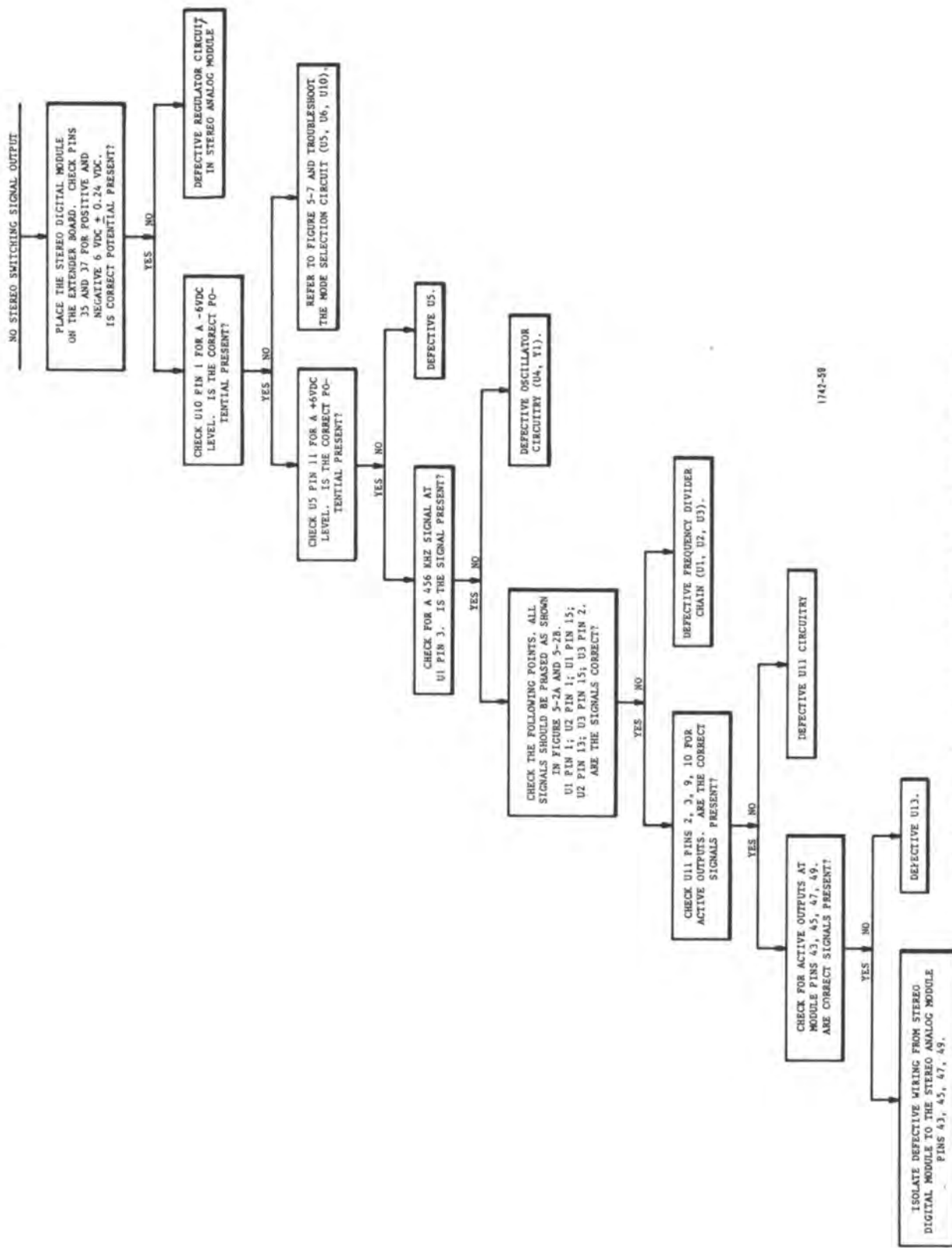

1742-58

Figure 5-6. No Stereo Switching Signal Output

LOCAL AND REMOTE MODE SELECTION INOPERATIVE (ANY MODE)

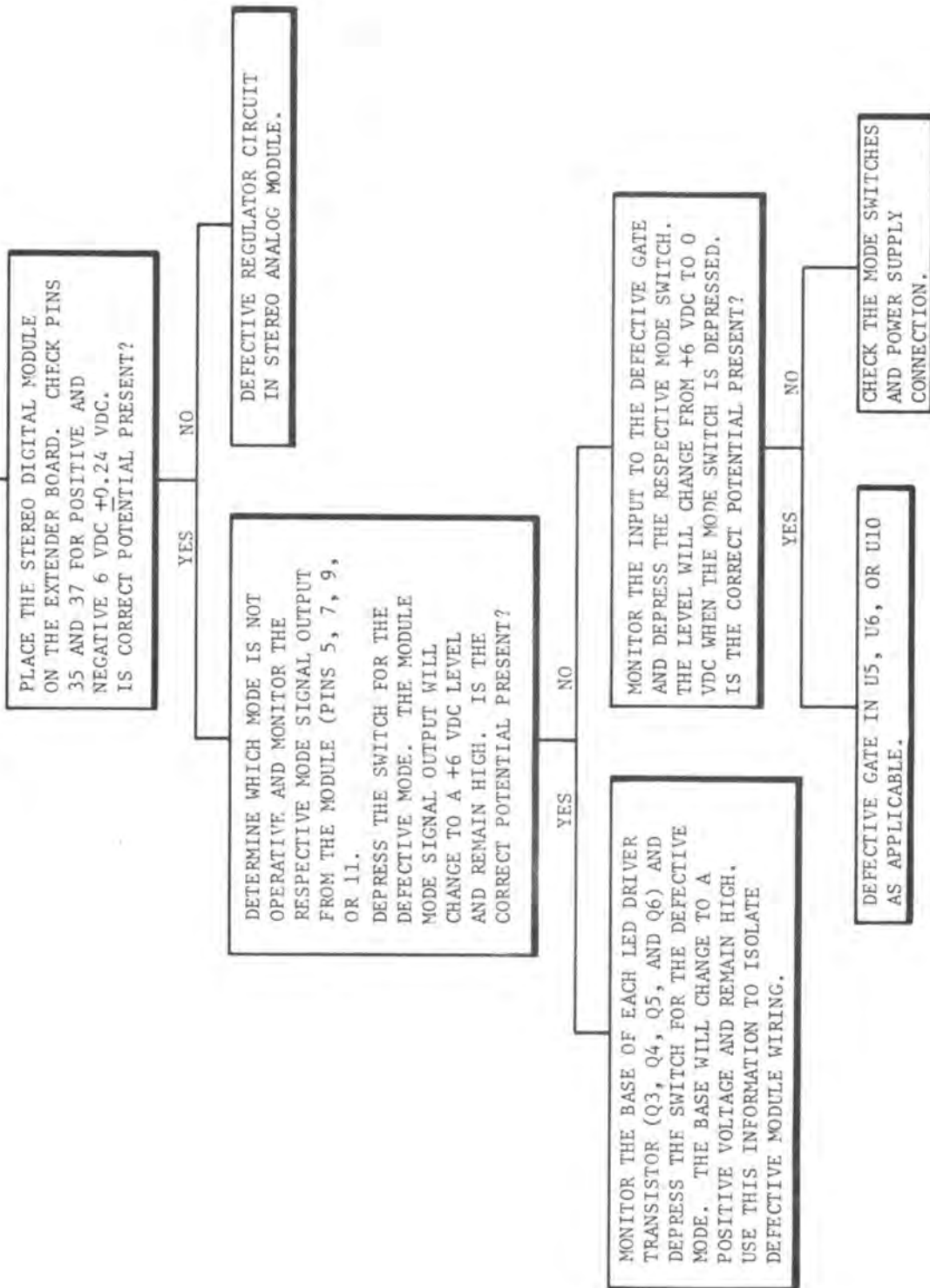

1742-66

Figure 5-7. Local and Remote Mode Selection Inoperative (Any Mode)

SECTION VI

PARTS LIST

6-1. GENERAL

6-2. Refer to table 6-1 for replaceable parts which are required for proper maintenance of the MS-15 STEREO DIGITAL MODULE. Table entries are indexed by component reference designator.

Table 6-1. STEREO DIGITAL MODULE Front Panel - 994 7990 001

REF. SYMBOL	HARRIS PART NO.	DESCRIPTION	QTY.
-----	992 4901 001	STEREO DIGITAL MODULE Circuit Board (Refer to figure 6-2.)	1

Table 6-2. STEREO DIGITAL MODULE Circuit Board - 992 4901 001

REF. SYMBOL	HARRIS PART NO.	DESCRIPTION	QTY.
C1	518 0054 000	Capacitor, Variable, 15-60 pF	1
C2	500 0803 000	Capacitor, 5 pF, 500V	1
C3	500 0759 000	Capacitor, 100 pF, 500V	1
C4 thru C7	516 0375 000	Capacitor, 0.01 uF, 50V	4
C8 thru C11	516 0063 000	Capacitor, 0.002 uF, 1 kV	4
C12	500 0833 000	Capacitor, 390 pF, 500V	1
C13	500 0804 000	Capacitor 10 pF, 500V	1
C14,C15	526 0049 000	Capacitor, 6.8 uF, 35V	2
C16	516 0375 000	Capacitor, 0.01 uF, 50V	1
C17	500 0842 000	Capacitor, 820 uF, 300V	1
C18,C19	508 0414 000	Capacitor, 0.01 uF, 50V	2
C20	526 0049 000	Capacitor, 6.8 uF, 35V	1
C21,C22	516 0453 000	Capacitor, 0.1 uF, 100V	2
C23 thru C28	516 0375 000	Capacitor, 0.01 uF, 100V	6
C29	526 0340 000	Capacitor, 1 uF, 35V	1
C30	526 0050 000	Capacitor, 1 uF, 35V	1
C31 thru C36	516 0375 000	Capacitor, 0.01 uF, 50V	6
C37,C38	526 0049 000	Capacitor, 6.8 uF, 35V	2
C40,C41	516 0375 000	Capacitor, 0.01 uF, 50V	2
CR1,CR2	384 0205 000	Diode, Silicon, 1N914	2
CR3,CR4	384 0662 000	LED, Red	2
CR5	384 0664 000	LED, Yellow	1

Table 6-2. STEREO DIGITAL MODULE Circuit Board - 992 4901 001 (Continued)

REF. SYMBOL	HARRIS PART NO.	DESCRIPTION	QTY.
CR6	384 0661 000	LED, Green	1
CR7	384 0205 000	Diode, 1N914	1
CR8 thru CR11	384 0431 000	Diode, 1N4001	4
CR12	384 0205 000	Diode, Silicon, 1N914	1
J1,J2	610 0679 000	Plug, Shorting	2
L1	492 0363 000	Inductor, Variable	1
Q1	380 0319 000	Transistor, MPS A14	1
Q2	380 0190 000	Transistor, 2N3906	1
Q3 thru Q7	380 0319 000	Transistor, MPS A14	5
R1	540 0153 000	Resistor, 22 Megohm, 1/2W, 5%	1
R2	540 1165 000	Resistor, 3300 ohm, 1/2W, 5%	1
R3	540 1159 000	Resistor, 100k ohm, 1/2W, 5%	1
R4	540 1162 000	Resistor, 1 Megohm, 1/2W, 5%	1
R5 thru R8	540 1153 000	Resistor, 8200 ohm, 1/2W, 5%	4
R9	540 1102 000	Resistor, 100 ohm, 1/2W, 5%	1
R10	540 1162 000	Resistor, 1 Megohm, 1/2W, 5%	1
R11	540 1102 000	Resistor, 100 ohm, 1/2W, 5%	1
R12	540 1182 000	Resistor, 2200 ohm, 1/2W, 5%	1
R13	540 1129 000	Resistor, 1500 ohm, 1/2W, 5%	1
R14	540 1182 000	Resistor, 2200 ohm, 1/2W, 5%	1
R15	540 1111 000	Resistor, 10k ohm, 1/2W, 5%	1
R16	540 1159 000	Resistor, 100k ohm, 1/2W, 5%	1

Table 6-2. STEREO DIGITAL MODULE Circuit Board - 992 4901 001 (Continued)

REF. SYMBOL	HARRIS PART NO.	DESCRIPTION	QTY.
R17	540 1182 000	Resistor, 2200 ohm, 1/2W, 5%	1
R18	540 1111 000	Resistor, 10k ohm, 1/2W, 5%	1
R19	550 0913 000	Potentiometer, 5k ohm	1
R20	540 1122 000	Resistor, 47k ohm, 1/2W, 5%	1
R21 thru R29	540 1111 000	Resistor, 10k ohm, 1/2W, 5%	9
R30	540 1116 000	Resistor, 1000 ohm, 1/2W, 5%	1
R31	540 1162 000	Resistor, 1 Megohm, 1/2W, 5%	1
R32 thru R36	540 1159 000	Resistor, 100k ohm, 1/2W, 5%	5
R37	540 1212 000	Resistor, 220k ohm, 1/2W, 5%	1
R38	540 1159 000	Resistor, 100k ohm, 1/2W, 5%	1
R39, R40	540 1151 000	Resistor, 10 ohm, 1/2W, 5%	2
R41 thru R44	540 1162 000	Resistor, 1 Megohm, 1/2W, 5%	4
R45	540 1159 000	Resistor, 100k ohm, 1/2W, 5%	1
R46	540 1162 000	Resistor, 1 Megohm, 1/2W, 5%	1
R47	540 1116 000	Resistor, 1000 ohm, 1/2W, 5%	1
S1 thru S4	604 0866 000	Switch, Pushbutton, SPDT	4
U1	382 0466 000	Integrated Circuit, Digital	1
U2	382 0397 000	Integrated Circuit, CD4013AE	1
U3	382 0466 000	Integrated Circuit, Digital	1
U4	382 0287 000	Integrated Circuit, CD4001AE	1
U5	382 0288 000	Integrated Circuit, CD4011AE	1
U6	382 0396 000	Integrated Circuit, CD4012AE	1

Table 6-2. STEREO DIGITAL MODULE Circuit Board - 992 4901 001 (Continued)

REF. SYMBOL	HARRIS PART NO.	DESCRIPTION	QTY.
U7	382 0472 000	Integrated Circuit, LM318N	1
U8	382 0452 000	Integrated Circuit, Comparator	1
U9	382 0397 000	Integrated Circuit, CD4013AE	1
U10	382 0396 000	Integrated Circuit, CD4012AE	1
U11	382 0548 000	Integrated Circuit, CD4042CN	1
U12	382 0510 000	Integrated Circuit, ILQ-74	1
U13	382 0523 000	Integrated Circuit, MC14066BCP	1
VTR5	670 0033 000	Light Dependent Resistor	1
XU1	404 0675 000	Socket, IC, 16 Contact	1
XU2	404 0674 000	Socket, IC, 14 Contact	1
XU3	404 0675 000	Socket, IC, 16 Contact	1
XU4 thru XU6	404 0674 000	Socket, IC, 14 Contact	3
XU7,XU8	404 0673 000	Socket, IC, 8 Contact	2
XU9,XU10	404 0674 000	Socket, IC, 14 Contact	2
XU11,XU12	404 0675 000	Socket, IC, 16 Contact	2
XU13	404 0674 000	Socket, IC, 14 Contact	1
XY1	404 0267 000	Socket, Crystal	1
Y1	444 2534 000	Crystal, 456.00 kHz	1
	843 1597 001	Printed Circuit Board	1

STEREO
ANALOG MODULE

This cover letter gives the information necessary to incorporate the MCN package into the technical manual. The following steps should be followed:

- a. Open the technical manual to the title page - this page can be distinguished by the copyright information located on the lower left corner of the page.
- b. Note the Revision level on the lower right corner of page.
- c. Directly behind this cover letter and continuing until the title page found in step a. is the MCN package for the technical manual.
- d. The first page of the MCN package should be entitled MANUAL REVISION HISTORY.
- e. The first column on the page is entitled MCN or REV. NO.
- f. Thumb through the MANUAL REVISION HISTORY sheets, if there are more than one, and locate the revision level found on the title page in step b. Manual Changes previous to this revision level were incorporated into the technical manual when that revision level was printed. Manual Changes listed under the revision level found in step b. and subsequent Manual Changes will need to be incorporated into the technical manual using the information provided under the column entitled DESCRIPTION CHANGE.
- g. Where needed, additional information or replacement schematics are provided, to aid in the updating of the technical manual. This information is located after the last page of the MANUAL REVISION HISTORY.

MANUAL REVISION HISTORY

MCN OR REV. NO	MCN OR REV. DATE	ECN NO.	DESCRIPTION OF CHANGE
F-1	02/25/82	26838	<p>Revision F: June 1981</p> <p>Change Figure 5-3. SEREO ANALOG MODULE SCHEMATIC 852 8408 001, Rev. D, Page 25/26, to Rev. E by adding arrow to -15 volt designator (bottom center of schematic) per attached sheet.</p>
F-2	09/08/82	26826	<p>Add to Table 6-2, page 36, STEREO ANALOG MODULE Circuit Board the following components: Capacitors C50,C51, 506 0234 000, 2200 pF, 63V, 5%, qty 2.</p> <p>Choke, RF, L1,L2, 494 0406 000, 68 uH, qty 2.</p> <p>Replace Figure 5-3. Stereo Analog Module Schematic, 852 8408 001, page 25/26, Rev. E with Rev. F.</p>

TECHNICAL MANUAL

STEREO ANALOG MODULE

994 7989 001



HARRIS CORPORATION

Broadcast Products Division

T.M. No. 888 1742 005

Printed: October 1977
Revision A: February 1978
Revision B: March 1979
Revision C: June 1979
Revision D: April 1980
Revision E: March 1981
Revision F: June 1981

MANUAL REVISION HISTORY

MCN OR REV.NO.	MCN OR REV. DATE	ECN NO.	DESCRIPTION OF CHANGE
F-1	02/25/82	26838	Revision F: June 1981 Change Figure 5-3. SEREO ANALOG MODULE SCHEMATIC 852 8408 001, Rev. D, Page 25/26, to Rev. E by adding arrow to -15 volt designator (bottom center of schematic) per attached sheet.

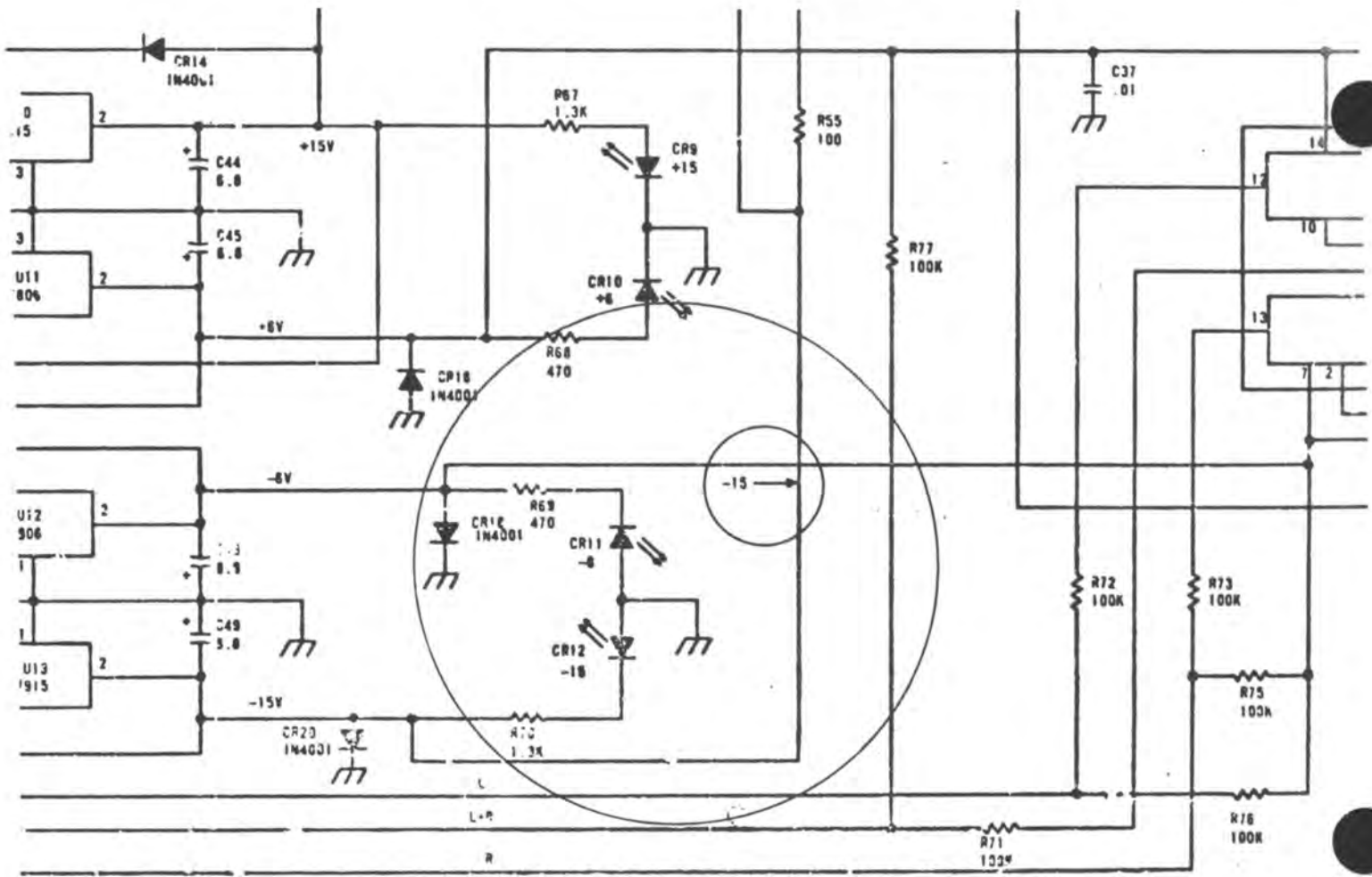

Location of Arrow Insertion on schematic 852 8408 001 to update to Rev. E.

WARNING

THE CURRENTS AND VOLTAGES IN THIS EQUIPMENT ARE DANGEROUS. PERSONNEL MUST AT ALL TIMES OBSERVE SAFETY REGULATIONS.

This manual is intended as a general guide for trained and qualified personnel who are aware of the dangers inherent in handling potentially hazardous electrical/electronic circuits. It is not intended to contain a complete statement of all safety precautions which should be observed by personnel in using this or other electronic equipment.

The installation, operation, maintenance and service of this equipment involves risks both to personnel and equipment, and must be performed only by qualified personnel exercising due care. HARRIS CORPORATION shall not be responsible for injury or damage resulting from improper procedures or from the use of improperly trained or inexperienced personnel performing such tasks.

During installation and operation of this equipment, local building codes and fire protection standards must be observed. The following National Fire Protection Association (NFPA) standards are recommended as references:

- Automatic Fire Detectors, No. 72E
- Installation, Maintenance, and Use of Portable Fire Extinguishers, No. 10
- Halogenated Fire Extinguishing Agent Systems, No. 12A

WARNING

ALWAYS DISCONNECT POWER BEFORE OPENING COVERS, DOORS, ENCLOSURES, GATES, PANELS OR SHIELDS. ALWAYS USE GROUNDING STICKS AND SHORT OUT HIGH VOLTAGE POINTS BEFORE SERVICING. NEVER MAKE INTERNAL ADJUSTMENTS, PERFORM MAINTENANCE OR SERVICE WHEN ALONE OR WHEN FATIGUED.

Do not remove, short-circuit or tamper with interlock switches on access covers, doors, enclosures, gates, panels or shields. Keep away from live circuits, know your equipment and don't take chances.

WARNING

IN CASE OF EMERGENCY ENSURE THAT POWER HAS BEEN DISCONNECTED.

Treatment of Electrical Shock

1. If victim is not responsive follow the A-B-Cs of basic life support.

PLACE VICTIM FLAT ON HIS BACK ON A HARD SURFACE

(A) AIRWAY

IF UNCONSCIOUS,
OPEN AIRWAY



LIFT UP NECK
PUSH FOREHEAD BACK
CLEAR OUT MOUTH IF NECESSARY
OBSERVE FOR BREATHING

(B) BREATHING

IF NOT BREATHING,
BEGIN ARTIFICIAL
BREATHING



TILT HEAD
PINCH NOSTRILS
MAKE AIRTIGHT SEAL

4 QUICK FULL BREATHS

REMEMBER MOUTH TO MOUTH RESUSCITATION
MUST BE COMMENCED AS SOON AS POSSIBLE

CHECK CAROTID PULSE

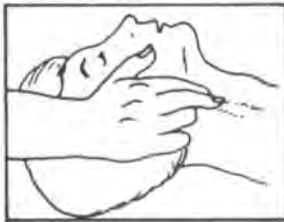

IF PULSE ABSENT,
BEGIN ARTIFICIAL
CIRCULATION

(C) CIRCULATION

DEPRESS STERNUM 1 1/2" TO 2"



APPROX. { ONE RESCUER
80 SEC. { 15 COMPRESSIONS
2 QUICK BREATHS

APPROX. { TWO RESCUERS
60 SEC. { 5 COMPRESSIONS
1 BREATH

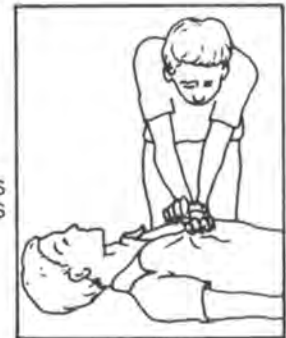

NOTE: DO NOT INTERRUPT RHYTHM OF COMPRESSIONS
WHEN SECOND PERSON IS GIVING BREATH

Call for medical assistance as soon as possible.

2. If victim is responsive.
 - a. keep them warm
 - b. keep them as quiet as possible
 - c. loosen their clothing
(a reclining position is recommended)

FIRST-AID

Personnel engaged in the installation, operation, maintenance or servicing of this equipment are urged to become familiar with first-aid theory and practices. The following information is not intended to be complete first-aid procedures, it is brief and is only to be used as a reference. It is the duty of all personnel using the equipment to be prepared to give adequate Emergency First Aid and thereby prevent avoidable loss of life.

Treatment of Electrical Burns

1. Extensive burned and broken skin
 - a. Cover area with clean sheet or cloth. (Cleanest available cloth article.)
 - b. Do not break blisters, remove tissue, remove adhered particles of clothing, or apply any salve or ointment.
 - c. Treat victim for shock as required.
 - d. Arrange transportation to a hospital as quickly as possible.
 - e. If arms or legs are affected keep them elevated.

NOTE

If medical help will not be available within an hour and the victim is conscious and not vomiting, give him a weak solution of salt and soda: 1 level teaspoonful of salt and 1/2 level teaspoonful of baking soda to each quart of water (neither hot or cold). Allow victim to sip slowly about 4 ounces (a half of glass) over a period of 15 minutes. Discontinue fluid if vomiting occurs. (Do not give alcohol.)

2. Less severe burns - (1st & 2nd degree)
 - a. Apply cool (not ice cold) compresses using the cleanest available cloth article.
 - b. Do not break blisters, remove tissue, remove adhered particles of clothing, or apply salve or ointment.
 - c. Apply clean dry dressing if necessary.
 - d. Treat victim for shock as required.
 - e. Arrange transportation to a hospital as quickly as possible.
 - f. If arms or legs are affected keep them elevated.

REFERENCE: ILLINOIS HEART ASSOCIATION

AMERICAN RED CROSS STANDARD FIRST AID AND PERSONAL SAFETY MANUAL
(SECOND EDITION)

TABLE OF CONTENTS

<u>Paragraph</u>		<u>Page</u>
SECTION I. GENERAL DESCRIPTION		
1-1.	Equipment Purpose	1
1-3.	Technical Characteristics	1
SECTION II. INSTALLATION		
2-1.	General	1
SECTION III. CONTROLS AND INDICATORS		
3-1.	General	1
SECTION IV. PRINCIPLES OF OPERATION		
4-1.	Circuit Description	14
4-2.	Input Circuit	14
4-3.	Input Protection Network	14
4-4.	Input Preamplifier	14
4-5.	Filter Circuit	14
4-9.	Switching Circuit	17
4-10.	Switch Drivers	17
4-15.	Mode Switching	17
4-17.	Monaural Operation	17
4-18.	Stereophonic Operation	18
4-19.	Output Circuit	18
4-21.	Power	18
SECTION V. MAINTENANCE		
5-1.	Corrective Maintenance	19
5-3.	Troubleshooting	19
SECTION VI. PARTS LIST		
6-1.	General	33

LIST OF TABLES

<u>Table</u>	<u>Page</u>
1-1. Technical Characteristics	2
3-1. STEREO ANALOG MODULE Controls and Indicators	4
3-2. Control Adjustments	6
5-1. STEREO ANALOG MODULE Fault Isolation Index	20
5-2. STEREO ANALOG MODULE Parts Index	22
6-1. STEREO ANALOG MODULE Front Panel	34
6-2. STEREO ANALOG MODULE Circuit Board	35

LIST OF ILLUSTRATIONS

<u>Figure</u>	<u>Page</u>
3-1. STEREO ANALOG MODULE	3
4-1. STEREO ANALOG MODULE Block Diagram	15
4-2. DSM Waveform	18
5-1. STEREO ANALOG MODULE Parts Layout	21
5-2. STEREO ANALOG MODULE Waveforms	24
5-3. STEREO ANALOG MODULE Schematic	25
5-4. No Output	27
5-5. No Audio From Left And/Or Right Channel (Pilot Present)	28
5-6. Noise or Distortion	29
5-7. Poor Separation	30
5-8. Poor Crosstalk	31
5-9. 38 kHz Carrier on Output	32

SECTION I
GENERAL DESCRIPTION

1-1. EQUIPMENT PURPOSE

1-2. The STEREO ANALOG MODULE produces a composite stereophonic signal from the left and right audio inputs. The composite output signal comprises a L+R baseband audio signal from 30 Hz to 15 kHz, a 19 kHz pilot signal at -20 dB for multiplex reference, and a L-R double sideband suppressed carrier signal centered at 38 kHz. The module interfaces with OVSC module to allow DTR filter provisions or use of the internal low-pass filter as desired. Selectable 75us, 50us, or 25us, or FLAT pre-emphasis is also provided.

1-3. TECHNICAL CHARACTERISTICS

1-4. Table 1-1 lists operating characteristics and parameters of the MS-15 STEREO ANALOG MODULE.

SECTION II
INSTALLATION

2-1. GENERAL

2-2. Refer to 888 1742 001, MS-15 Exciter, Section II, Installation.

SECTION III
CONTROLS AND INDICATORS

3-1. GENERAL

3-2. Figure 3-1 shows the location of each control or indicator associated with the MS-15 STEREO ANALOG MODULE and table 3-1 lists the controls and indicators with a description of each item listed. Control setup adjustments are listed in table 3-2.

Table 1-1. Technical Characteristics

FUNCTION	CHARACTERISTIC
<p><u>INPUTS</u></p> <p>POWER:</p> <p>SIGNAL:</p> <p> Audio (Left and Right Channel)</p> <p> Pilot</p> <p>CONTROL:</p> <p> Stereo Switching</p> <p> Mode Switching</p>	<p>+20 Vdc @ 0.110 amperes -20 Vdc @ 0.105 amperes</p> <p>+10 dBm +1 dBm for 100% modulation at 400 Hz. 600 ohm balanced resistive input impedance.</p> <p>1.7V p-p sinusoidal 19 kHz Pilot.</p> <p>12V p-p in phase and inverted 38 kHz square waves (CMOS logic level).</p> <p>12V p-p in phase and inverted 114 kHz square waves (CMOS logic level).</p> <p>+6 Vdc for Selected Mode. -6 Vdc for inhibit (CMOS logic level).</p>
<p><u>OUTPUTS</u></p> <p>POWER:</p> <p>SIGNAL:</p>	<p>+6 Vdc @ 0.025 amperes -6 Vdc @ 0.022 amperes</p> <p>2.8V p-p Composite Stereo Output</p>

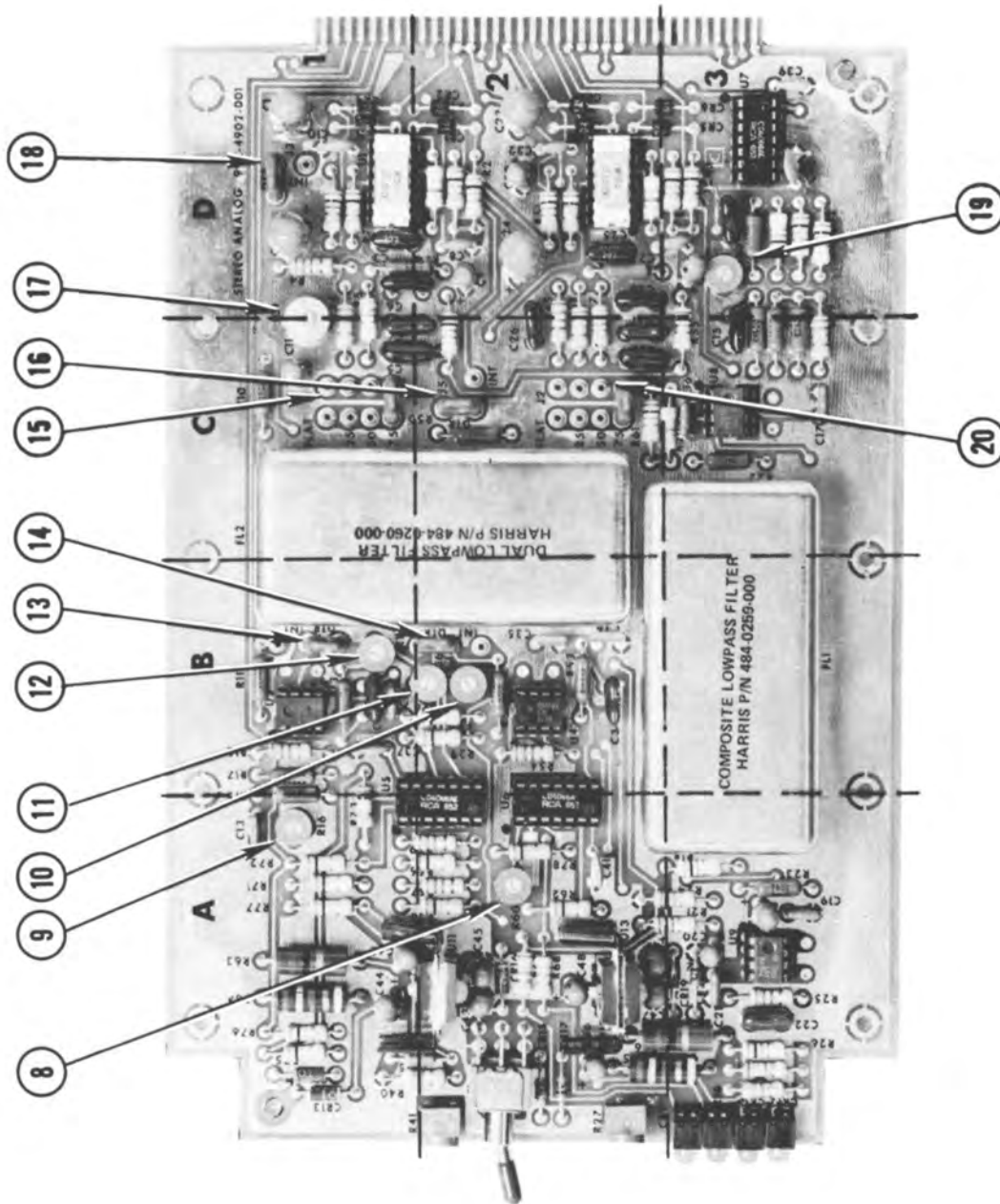

1742-46

Figure 3-1. STEREO ANALOG MODULE

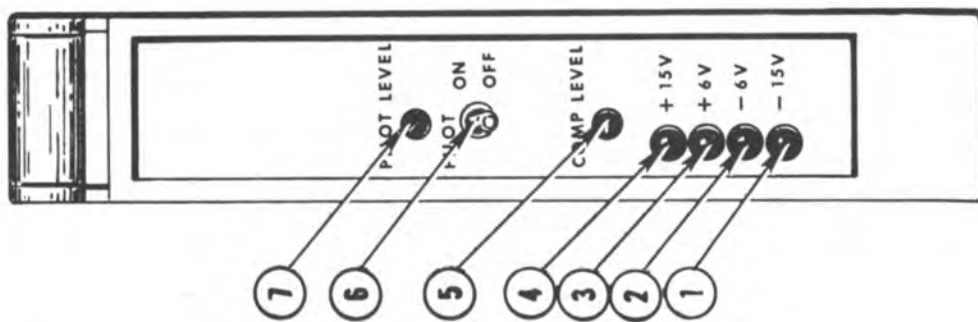

Table 3-1. STEREO ANALOG MODULE Controls and Indicators

REF.	CONTROL/INDICATOR	FUNCTION
1	-15V Indicator (CR12)	Illuminates to indicate the STEREO ANALOG MODULE -15 volt regulator is operational.
2	-6V Indicator (CR11)	Illuminates to indicate the STEREO ANALOG MODULE -6 volt regulator is operational.
3	+6V Indicator (CR10)	Illuminates to indicate the STEREO ANALOG MODULE +6 volt regulator is operational.
4	+15V Indicator (CR9)	Illuminates to indicate the STEREO ANALOG MODULE +15 volt regulator is operational.
5	COMP LEVEL Control (R27)	Adjusts the signal level output from the STEREO ANALOG MODULE.
6	PILOT ON/OFF Switch (S1)	Enables or inhibits the pilot subcarrier.
7	PILOT LEVEL Control (R41)	Adjusts the modulation level of the pilot carrier.
8	MONO GAIN Control (R60)	Adjusts monaural audio level in relation to the stereophonic audio level.
9	38 kHz NULL Control (R16)	Adjusts dc offset between left and right switch drivers to null 38 kHz signal.
10	RIGHT SEPARATION Control (R31)	Adjusts left into right stereophonic audio separation.
11	LEFT SEPARATION Control (R28)	Adjusts right into left stereophonic audio separation.
12	GAIN MATCH Control (R14)	Adjusts the left channel gain to equal the right channel gain for minimum crosstalk.

Table 3-1. STEREO ANALOG MODULE Controls and Indicators (Continued)

REF.	CONTROL/INDICATOR	FUNCTION
13	INT/DTR Filter Selector (J4)	Selects the internal low pass filter or enables the DTR filter.
14	INT/DTR Filter Selector (J6)	Selects the internal low pass filter or enables the DTR filter.
15	75/50/25/FLAT Left Channel Pre-emphasis Selector (J1)	Selects left channel stereophonic input pre-emphasis.
16	INT/DTR Filter Selector (J5)	Selects the internal low pass filter or enables the DTR filter.
17	PRE-EMPH MATCH Adjustment (C4)	Adjusts pre-emphasis characteristics of the left channel to match the right channel pre-emphasis characteristics for minimum crosstalk.
18	INT/DTR Filter Selector (J3)	Selects the internal low pass filter or enables the DTR filter.
19	114 kHz NULL Control Control (R37)	Adjusts the 114 kHz level to cancel the third harmonic of the 38 kHz signal (114 kHz).
20	75/50/25/FLAT Right Channel Pre-emphasis Selector (J2)	Selects right channel stereophonic input pre-emphasis.

Table 3-2. Control Adjustments

CONTROL	ADJUSTMENT
<p>PILOT LEVEL Control (R41)</p>	<ol style="list-style-type: none"> 1. Connect the exciter rf output to a 50 ohm load through a directional coupler or line sampler. 2. Connect a modulation monitor to the line sampler or the forward port of the directional coupler. 3. Connect a stereo monitor to the composite output to the modulation monitor. 4. Depress the SCA 1 and SCA 2 OFF switches. The OFF indicator on each SCA module will illuminate. 5. Adjust R41 to obtain the desired amount of pilot signal (8% to 10%). Note the level. 6. Depress the SCA 1 ON switch. The SCA 1 ON indicator will illuminate. 7. If the pilot signal drops from the level adjusted in step 5, adjust R41 slightly to compensate for the drop. 8. Reconnect the exciter output to the load.
<p>COMP LEVEL Control (R27)</p>	<ol style="list-style-type: none"> 1. Disconnect the stereo audio inputs from LEFT FRONT + and - (TB1 pins 1 and 3) and RIGHT FRONT + and - (TB1 pins 4 and 6) on the rear of the exciter. 2. Apply a 400 Hz sinewave at +10 dBm to both inputs simultaneously. 3. Depress the LEFT MODULATION meter switch. Adjust the 400

Table 3-2. Control Adjustments (Continued)

CONTROL	ADJUSTMENT
<p>MONO GAIN Control (R60)</p>	<p>Hz signal level until the MODULATION meter indicates 100%.</p> <ol style="list-style-type: none"> 4. Depress the B-BAND MODULATION meter switch. Adjust R27 until the MODULATION meter indicates 100%. 5. Remove the 400 Hz test signal and reconnect the stereo audio inputs. 1. Disconnect the stereo audio inputs from LEFT FRONT + and - (TB1 pins 1 and 3) and RIGHT FRONT + and - (TB1 pins 4 and 6) on the rear of the exciter. 2. Apply a 400 Hz sinewave at +10 dBm to both inputs simultaneously. 3. Remove the module. Mount the module in the exciter using the extender board provided with the exciter. 4. Depress the LEFT MODULATION meter switch. Adjust the 400 Hz signal level until the MODULATION meter indicates 100%. 5. Depress the MONO L mode switch on the STEREO DIGITAL module. The MONO L indicator will illuminate. 6. Depress the LEFT MODULATION meter switch and adjust R60 to obtain an indication of 100% on the MODULATION meter. 7. Remove the module and extender board and replace the module in the exciter. Remove the 400 Hz

Table 3-2. Control Adjustments (Continued)

CONTROL	ADJUSTMENT
<p>38 KHZ NULL Control (R16)</p>	<p>test signal and reconnect the stereo audio inputs.</p> <ol style="list-style-type: none"> 1. Connect the exciter rf output to a 50 ohm load through a directional coupler or line sampler. 2. Connect a modulation monitor to the line sampler or the forward port of the directional coupler. 3. Connect a stereo monitor to the composite output to the modulation monitor and adjust the stereo monitor to the 38 kHz position. 4. Disable all modulation to the exciter. 5. Remove the module. Mount the module in the exciter using the extender board provided with the exciter. 6. Depress the STEREO DIGITAL module STEREO switch. The STEREO indicator will illuminate. 7. Set the PILOT ON/OFF switch to OFF. 8. Adjust R16 to obtain a minimum indication on the stereo monitor. 9. Remove the module and extender board and replace the module in the exciter. Set the PILOT ON/OFF switch to ON and reconnect the exciter output to the load.

Table 3-2. Control Adjustments (Continued)

CONTROL	ADJUSTMENT
<p>114 KHZ NULL Control (R37)</p>	<p style="text-align: center;">NOTE</p> <p>The 114 KHZ NULL control (R37) is factory preset and should not be adjusted in the field unless the circuit is repaired. Adjustment of R37 affects several parameters and requires subsequent completion of the LEFT SEPARATION Control (R28)/-RIGHT SEPARATION Control (R31)/GAIN MATCH Control (R14)/PRE-EMPHASIS MATCH Adjustment (C4) adjustment procedure.</p> <ol style="list-style-type: none"> 1. Remove the module. Mount the module in the exciter using the extender board provided with the exciter. 2. Disconnect the stereo audio input from the LEFT FRONT + and - (TB1 pins 1 and 3) on the rear of the exciter. 3. Apply a 400 Hz sinewave at +10 dBm to the left channel only. 4. Connect a spectrum analyzer to pin 70. 5. Depress the LEFT MODULATION meter switch. Adjust the 400 Hz signal level until the MODULATION meter indicates 100%. 6. Adjust R37 to obtain a minimum indication of the 114 kHz signal on the spectrum analyzer (typical suppression 70 dB). 7. Disconnect the spectrum analyzer.

Table 3-2. Control Adjustments (Continued)

CONTROL	ADJUSTMENT
<p>GAIN MATCH Control (R14)</p>	<ol style="list-style-type: none"> 2. Depress the RIGHT MODULATION meter switch. Adjust the 400 Hz signal level until the MODULATION meter indicates 100%. 3. Adjust R31 to obtain the flattest composite signal base line indication on the oscilloscope. 4. Set the STEREO OVSC module IN/OUT switch to OUT. 5. Remove the 400 Hz test signal from the right channel. 1. Connect a 100 Hz sinewave to both the LEFT FRONT + and - (Tb1 pins 1 and 3) and the RIGHT FRONT + and - (Tb1 pins 4 and 6) (both channels strapped together so that L = R). 2. Depress the LEFT MODULATION meter switch. Adjust the 100 Hz signal level until the MODULATION meter indicates 100%. 3. Adjust C4 to midrange. 4. Using a spectrum analyzer connected to pin 70 or a stereo modulation monitor on the exciter output adjusted to the L-R position, adjust R14 for a minimum indicator of the L-R signal (typical suppression > 65 dB). 5. Remove the 100 Hz test signal from the exciter stereo audio inputs.

Table 3-2. Control Adjustments (Continued)

CONTROL	ADJUSTMENT
<p>PRE-EMPHASIS MATCH Adjustment (C4)</p>	<ol style="list-style-type: none"> 1. Connect a 15 kHz sinewave to both the LEFT FRONT + and - (Tb1 pins 1 and 3) and the RIGHT FRONT + and - (Tb1 pins 4 and 6) (both channels strapped together so that L = R). 2. Depress the LEFT MODULATION meter switch. Adjust the 15 kHz signal level until the MODULATION meter indicates 100%. 3. Adjust C4 for a minimum indication of the L-R signal (typical suppression 60 dB). Note the stereo audio inputs. 4. Remove the 15 kHz test signal from the exciter stereo audio inputs. 5. Connect a 400 Hz sinewave to the LEFT FRONT + and - (Tb1 pins 1 and 3). For test purposes only, cross connect the left and right exciter stereo audio inputs out of phase so that L = -R as follows: <ul style="list-style-type: none"> Tb1 pin 1 to Tb1 pin 6 Tb3 pin 3 to Tb1 pin 4 6. Depress the LEFT MODULATION meter switch. Adjust the 400 Hz signal level until the MODULATION meter indicates 100%. 7. If a stereo modulation monitor is used, adjust the monitor to the L + R signal. If L+R suppression is different in level from L-R indication in step 3, alternately adjust R28 and R41 slightly equal amounts in the same direction until the L + R

Table 3-2. Control Adjustments (Continued)

CONTROL	ADJUSTMENT
	<p>suppression is equal to the L - R suppression noted in step 3.</p> <ol style="list-style-type: none"> 8. Remove the 400 Hz test signal and straps from the exciter stereo audio inputs. 9. Connect a 400 Hz sinewave to the LEFT FRONT + and - (TBI pins 1 and 3). 10. Depress the LEFT MODULATION meter switch. Adjust the 400 Hz signal level until the MODULATION meter indicates 100%. 11. Check LEFT SEPARATION and RIGHT SEPARATION. Ensure the separation has not degraded. 12. Perform the PILOT LEVEL Control (R41) adjustment procedure, steps 1 through 4. 13. Perform the MONO GAIN Control (R27) adjustment procedure, steps 1 through 6. 14. Disconnect the oscilloscope and spectrum analyzer from the module. Remove the module and extender board and replace the module in the exciter. 15. Remove the 400 Hz test signal and reconnect the stereo audio inputs. Reconnect the exciter output to the load. 16. Set the PILOT ON/OFF switch to ON. Set the STEREO OVSC Module IN/OUT switch to ON.

SECTION IV

PRINCIPLES OF OPERATION

4-1. CIRCUIT DESCRIPTION

4-2. INPUT CIRCUIT

4-3. INPUT PROTECTION NETWORK. Two channel audio input from the RFI filter is applied to transformerless unity gain instrumentation amplifiers (U1 and U2) through input protection networks (see figure 4-1). Damage to the preamplifier circuits from an excessive input signal is prevented by a configuration of four diodes connected to the +15 Vdc sources. If a signal or transient exceeding the power supply potential appears at the module input, the portion of the input which exceeds the power supply potential will be shunted by the diodes to the +15 Vdc power supply to limit the signal.

4-4. INPUT PREAMPLIFIER. The input preamplifiers differ from standard operational amplifiers by the inputs and the methods through which feedback is obtained. Each amplifier responds only to the difference in potential between the two inputs. If the same signal is applied to both inputs simultaneously or if only one input is driven and the connection to the second input is opened, the output will be zero. The amplifier therefore behaves as a transformer with response to dc. The amplifiers also provide the transformer's advantages of isolation and hum rejection without the problems of limited frequency response and phase distortion. Pre-emphasis selectors J1 and J2 allow pre-emphasis selection of 75us, 50us, 25us, or FLAT response. Amplifier gain is determined by resistors R7, R49 and the pre-emphasis network. The PRE-EMPH MATCH control (C4) in the left channel preamplifier input allows adjustment of the left channel pre-emphasis circuit to match the right channel pre-emphasis characteristics. The pre-emphasized audio is applied to DTR filter selector J3 in the left channel and DTR filter selector J5 in the right channel.

4-5. FILTER CIRCUIT

4-6. Pre-emphasized audio from the input preamplifiers is applied to DTR (Dynamic Transient Response) filter selectors J3 in the left channel and J5 in the right channel. Outputs to the ac metering circuits allow monitoring of the left and right pre-emphasized levels.

4-7. Normally the STEREO ANALOG MODULE will be used with the STEREO OVSC module in which the STEREO ANALOG MODULE filters are used as part of the DTR filtering process. However, the STEREO ANALOG MODULE includes its own audio low-pass filters and can function without the STEREO OVSC module if desired.

4-8. The DTR filter selectors allow selection of the OVSC module DTR filter circuitry or allow use of the STEREO ANALOG MODULE 17.5 kHz low-pass filters as desired. In any case, all the DTR filter selectors (J3 and J4 in the left channel and J5 and J6 in the right channel) must all be positioned in corresponding locations. If the DTR filter is jumpered out of the circuit (INT position), the OVSC module IN/OUT switch must be placed OUT or the OVSC module must be removed from the exciter.

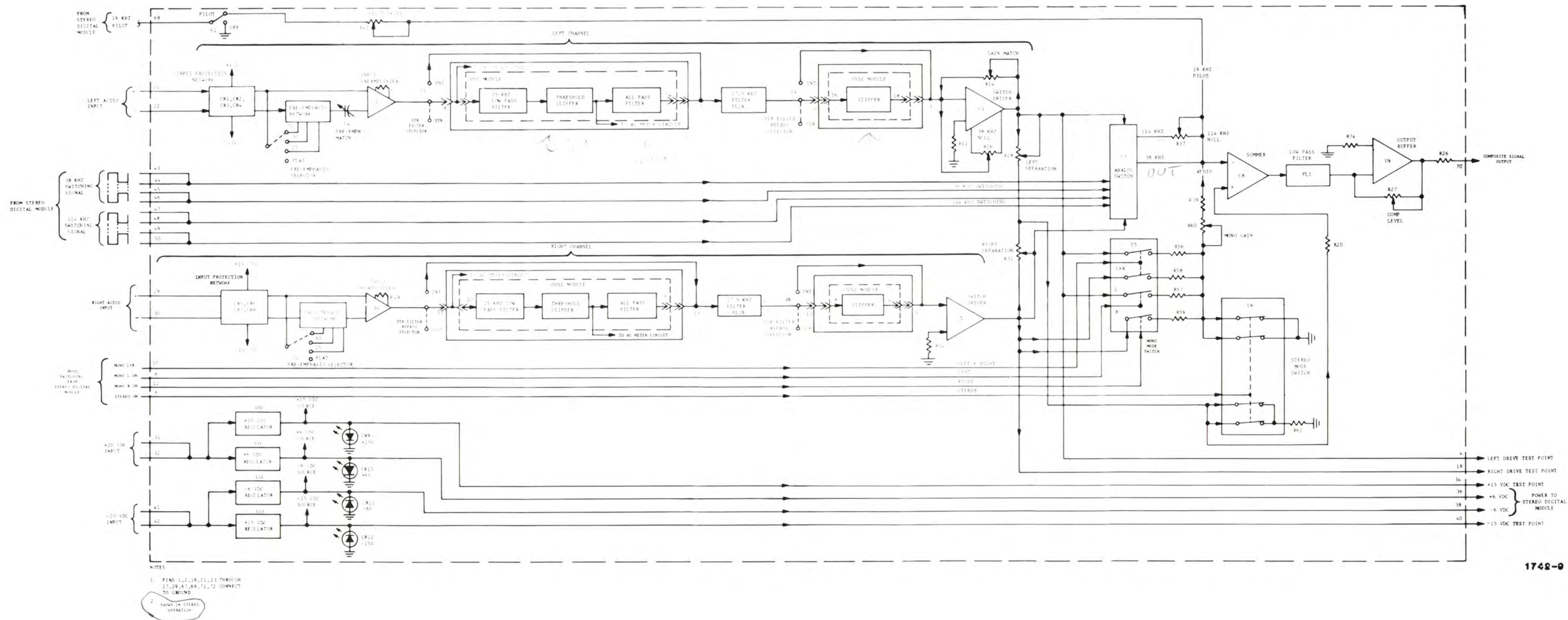

1742-0

FIGURE 4-1. STEREO ANALOG MODULE BLOCK DIAGRAM

4-9. SWITCHING CIRCUIT

4-10. SWITCH DRIVERS. The pre-emphasized and filtered audio is applied to switch driver U3 in the left channel and U4 in the right channel. The gain of the left channel driver is adjusted to match the right channel amplifier gain with the GAIN MATCH control (R14). The 38 kHz NULL control (R16) adjusts 38 kHz suppression by matching the dc offsets between the left and right channel switch drivers. The LEFT SEPARATION (R28) adjusts right into left audio and the RIGHT SEPARATION (R31) adjusts left into right audio to obtain maximum channel separation.

4-11. All waveforms used in the STEREO ANALOG MODULE are generated by the synchronous divider in the STEREO DIGITAL module. This ensures correct phase relationships among the 38 kHz and 114 kHz inverted and non-inverted switching signals and the 19 kHz pilot signal.

4-12. The two sets of square wave switching signals input to the analog switches cause the switches to sample the left and right audio channels at a 38 kHz and 114 kHz rate. The switches output a 38 kHz and 114 kHz sampled audio signal which is summed with the pilot signal at the inverting input to sum amplifier U8. The 114 kHz amplitude is adjusted to the same amplitude as the third harmonic of the 38 kHz signal (114 kHz) by the 114 kHz NULL control (R37). As the two signals are 180 degrees out of phase when summed, the two signals algebraically add to zero and cancel. Therefore the resultant sampling waveform contains no 114 kHz component. The pilot signal amplitude is adjusted with the PILOT LEVEL control (R41) and the PILOT ON/OFF switch (S1) allows the pilot signal to be interrupted for test purposes.

4-13. After low-pass filtering, the 38 kHz double sideband L-R signal peak amplitude must equal L+R audio baseband peak amplitude. This is accomplished by subtracting a small portion of the left and right audio signal fed through R20 from the sampled audio signal at the input of sum amplifier U8. Relative signal amplitudes of the 38 kHz, 114 kHz, and inverted left and right audio components at the summed input are 1.0V P-P, and 0.333 P-P, and 0.03V P-P respectively.

4-14. For monaural operation, the sampling signals and the pilot signal from the STEREO DIGITAL module are inhibited. Switches in U5 select the L+R, L, or R monaural modes. The signal level is controlled by the MONO GAIN control (R60) with the monaural signal applied to U8 through resistor R39.

4-15. MODE SWITCHING

4-16. Mode switching is controlled by CMOS logic inputs for stereo, mono left, mono right, and mono left plus right from the STEREO DIGITAL MODULE.

4-17. MONAURAL OPERATION. If a monaural mode is selected, the stereo mode line is driven LOW which opens the four switches in U6. Operation of the 38 kHz and the 114 kHz sampling signals and the 19 kHz pilot signal is inhibited by control circuitry in the STEREO DIGITAL module which opens the sampling switches. A positive six volt dc level input from the STEREO DIGITAL

module on the selected monaural mode line will close the appropriate mono mode switches in U5 and connect the desired audio source to the sum amplifier input through the MONO GAIN control (R60). Resistors R56, R57, R58, and R59 connected to the mono mode switch ensure the correct audio level is maintained for each mono mode.

4-18. STEREOPHONIC OPERATION. If stereophonic operation is selected, a positive six volt dc level output from the STEREO DIGITAL module on the stereo mode line activates the stereo mode switches (U6). One portion of the switch connected between the LEFT SEPARATION and RIGHT SEPARATION controls applies a portion of the (L+R) signal required for stereophonic operation to the non-inverting input of the sum amplifier. The second portion of the switch inhibits monaural operation by effectively grounding the monaural audio line. The 38 kHz and 114 kHz sampling signals and the 19 kHz pilot signal output from the STEREO DIGITAL module are enabled during stereophonic operation.

4-19. OUTPUT CIRCUIT

4-20. The output of the sum amplifier feeds the output amplifier through FL-1 which provides the required low-pass filtering. Output buffer U9 amplifies the signal level and provides a low impedance output. The COMP LEVEL control R27 adjusts the composite signal level to 1.0 VRMS for 100% modulation to drive the MOD OSC module circuitry. Several cycles of the digital sampling signal and the 38 kHz fundamental component as would appear at the output of sum amplifier (U8) (pilot off) are shown in figure 4-2.

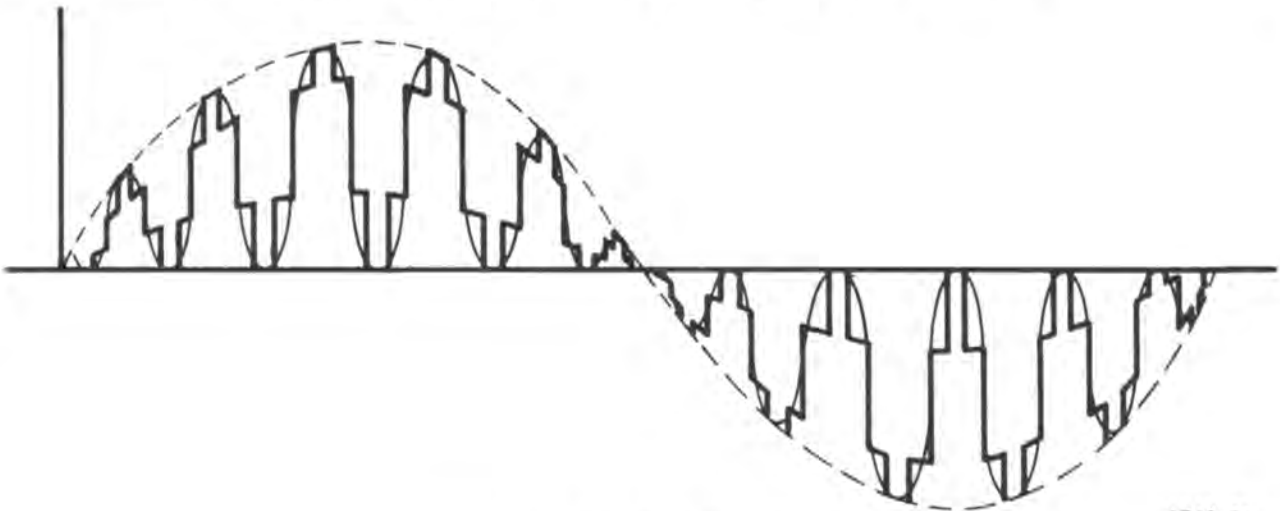

Figure 4-2. DSM Waveform

1742-31

4-21. POWER

4-22. Positive 20 Vdc enters the module on pins 31 and 32 and negative 20 Vdc enters the module on pins 41 and 42. Regulated potentials to operate the module internal circuitry are developed by regulators U10 (+15 Vdc), U11 (+6 Vdc), U12 (-15 Vdc), and U13 (-6 Vdc). Light emitting diodes CR9 through CR12 provide a visual indication of the positive and negative fifteen

and six volt supplies. Test points are provided to assist in checking regulator outputs. Additionally, +6 Vdc is output from the STEREO ANALOG MODULE to power the circuitry in the STEREO DIGITAL module.

SECTION V

MAINTENANCE

5-1. CORRECTIVE MAINTENANCE

5-2. The MS-15 FM exciter module philosophy consists of problem isolation to a specific area or individual component and subsequent isolation and replacement of the defective component.

5-3. TROUBLESHOOTING

5-4. In event of problems, the trouble area must first be isolated to a specific area. Most troubleshooting consists of visual checks. The MODULATION meter, MULTIMETER, fuse F1, circuit breaker CB1, and the indicators on each module should be used to determine in which area the malfunction exists. All module power supplies are equipped with LEDs which indicate the module power supply status. A single dark LED would indicate a problem associated with an individual module monolithic voltage regulator. A consistent pattern of dark LEDs however, would indicate an exciter dc distribution bus fault.

5-5. Once the trouble is isolated to a specific area, refer to the theory section of this manual for circuit discussion to aid in problem resolution. Table 5-1 lists typical trouble symptoms pertaining to the individual module operation with references to fault isolation diagrams listing probable causes and corrective actions. A corrective action given for a trouble symptom is not necessarily the only answer to a problem. It only tends to lead the repairman into the area that may be causing the trouble. An extender board (HARRIS PN 992 4989 001) is provided with the exciter to assist in troubleshooting. In event parts are required, refer to Section VI, Parts List. The following information is contained in this section as an aid to maintenance:

<u>REFERENCE</u>	<u>TITLE</u>	<u>NUMBER</u>
Figure 5-1	STEREO ANALOG MODULE Parts Layout	--- ---- ---
Table 5-2	STEREO ANALOG MODULE Parts Index	--- ---- ---
Figure 5-2	STEREO ANALOG MODULE Waveforms	--- ---- ---
Figure 5-3	STEREO ANALOG MODULE Schematic	852 8408 001

Table 5-1. STEREO ANALOG MODULE Fault Isolation Index

SYMPTOM	DEFECT/REFERENCE
NO OUTPUT	Figure 5-4
NO AUDIO FROM LEFT AND/OR RIGHT CHANNEL (pilot present).	Figure 5-5
NOISE	Figure 5-6
POOR SEPARATION	Figure 5-7
POOR CROSSTALK	Figure 5-8
38 KHZ CARRIER ON OUTPUT	Figure 5-9

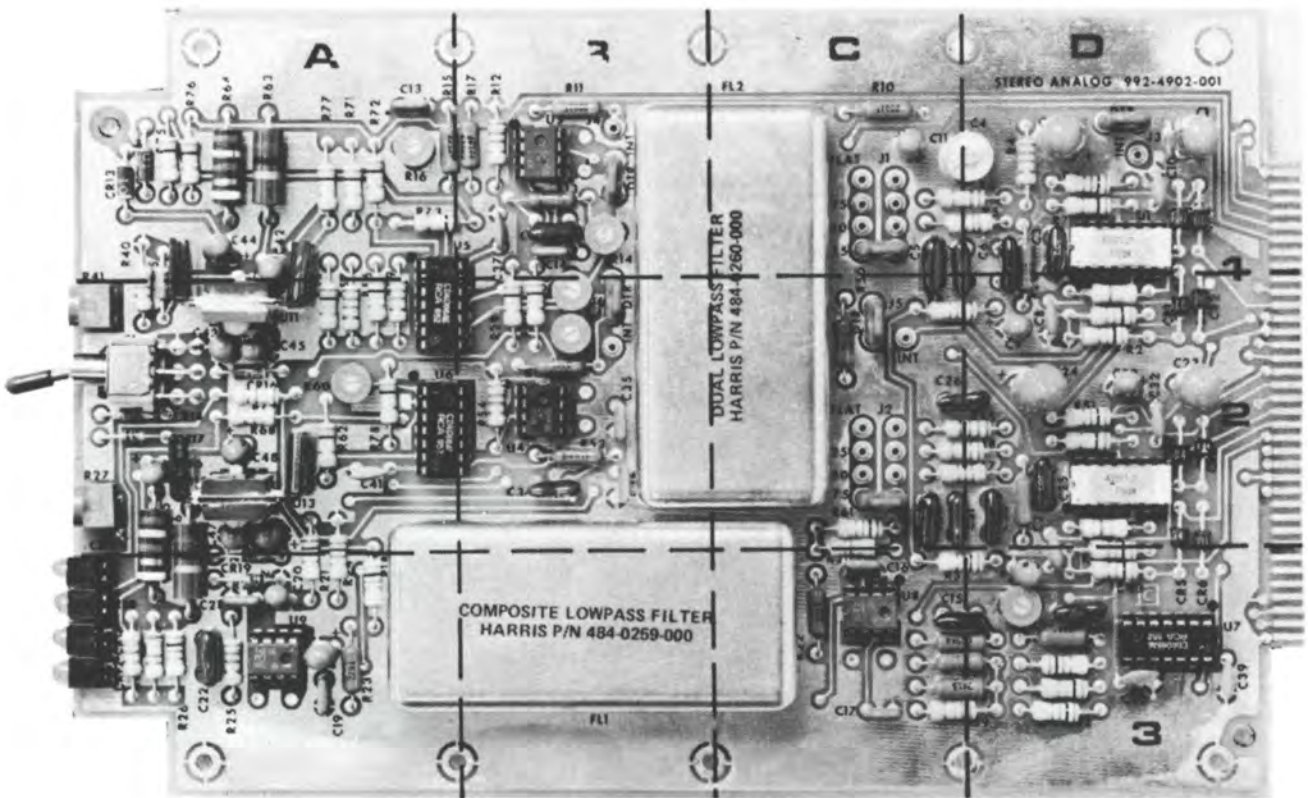

1742-47

Figure 5-1. STEREO ANALOG MODULE Parts Layout

Table 5-2. STEREO ANALOG MODULE Parts Index

SYMBOL	LOCATION	SYMBOL	LOCATION	SYMBOL	LOCATION	SYMBOL	LOCATION	SYMBOL	LOCATION
C1	D1	C29	C2	CR1	D2	J1	C1		
C2	D1	C30	D2	CR2	D2	J2	C2		
C3	D1	C31	D2	CR3	D1	J3	D1		
C4	D1	C32	D2	CR4	D1	J4	B1		
C5	C1	C33	D2	CR5	D3	J5	C2		
C6	D1	C34	B2	CR6	D3	J6	B2		
C7	C1	C35	B2	CR7	D2				
C8	D2	C36	B2	CR8	D2				
C9	D2	C37	B1	CR9	A3				
C10	D1	C38	D3	CR10	A3				
C11	C1	C39	D3	CR11	A3	R1	D2		
C12	B1	C40	D3	CR12	A3	R2	D2		
C13	A1	C41	A2	CR13	A1	R3	D2		
C14	B1	C42	A1	CR14	A1	R4	D1		
C15	C3	C43	A2	CR15	A2	R5	D1		
C16	C3	C44	A1	CR16	A2	R6	D1		
C17	C3	C45	A2	CR17	A2	R7	D1		
C18	A3	C46	A2	CR18	A2	R8	C2		
C19	A3	C47	A2	CR19	A3	R9	D1		
C20	A3	C48	A2	CR20	A3	R10	C1		
C21	A3	C49	A2			R11	B1		
C22	A3					R12	B1		
C23	D2					R13	B1		
C24	D2			FL1	B3	R14	B1		
C25	D2			FL2	C1	R15	A1		
C26	C2					R16	A1		
C27	D2					R17	B1		
C28	D3					R18	A3		
						R19	C3		

Table 5-2. STEREO ANALOG MODULE Parts Index (Continued)

SYMBOL	LOCATION	SYMBOL	LOCATION	SYMBOL	LOCATION	SYMBOL	LOCATION
R20	C3	R48	D2	R76	A1		
R21	A3	R39	D2	R77	A1		
R22	C3	R50	C2	R78	A2		
R23	A3	R51	D2	S1	A2		
R24	A3	R52	B2	U1	D1		
R25	A3	R53	B2	U2	D2		
R26	A3	R54	B2	U3	B1		
R27	A2	R55	C3	U4	B2		
R28	B2	R56	A2	U5	A2		
R29	B2	R57	A2	U6	A2		
R30	B2	R47	A2	U7	D3		
R31	B2	R59	A2	U8	C3		
R32	D3	R60	A2	U9	A3		
R33	D3	R61	C2	U10	A2		
R34	C3	R62	A2	U11	A2		
R35	C3	R63	A1	U12	A2		
R36	D3	R64	A1	U13	A2		
R37	D3	R65	A3				
R38	D3	R66	A3				
R39	C3	R56	A2				
R40	A2	R68	A2				
R41	A2	R69	A3				
R42	D2	R70	A3				
R43	D3	R71	A1				
R44	D3	R72	A1				
R45	D2	R73	A1				
R46	D2	R74	D1				
R47	D2	R75	A1				

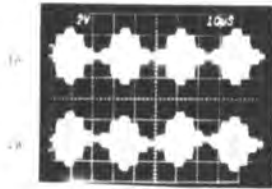

- TEST REQUIREMENTS: A. 1 kHz signal input to exciter left channel.
 B. Oscilloscope synchronized to pilot frequency.
- 1A DSM sampling waveform at UB pin 6 with the PILOT ON/OFF switch set to OFF.
 1B DSM sampling waveform at UB pin 6 with the PILOT ON/OFF switch set to ON.

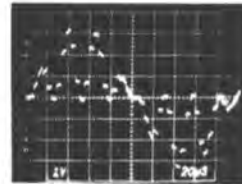

- TEST REQUIREMENTS: A. 5 kHz signal input to exciter left channel.
 B. Oscilloscope adjusted to single sweep storage mode.
 C. PILOT ON/OFF switch set to OFF.
- 2 DSM sampling waveform at UB pin 6.

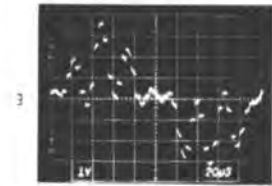

- TEST REQUIREMENTS: A. 5 kHz signal input to exciter left channel.
 B. Oscilloscope adjusted to single sweep storage mode.
 C. PILOT ON/OFF switch set to ON.
- 3 DSM sampling waveform at UB pin 6.

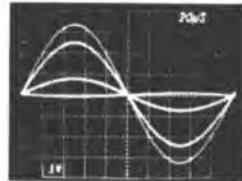

- TEST REQUIREMENTS: A. 5 kHz signal input to exciter left channel.
 B. Oscilloscope synchronized to audio input.
 C. PILOT ON/OFF switch set to OFF.
- 4 DSM sampling waveform at UB pin 6.

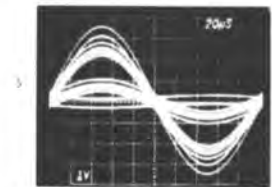

- TEST REQUIREMENTS: A. 5 kHz signal input to exciter left channel.
 B. Oscilloscope synchronized to audio input.
 C. PILOT ON/OFF switch set to ON.
- 5 DSM sampling waveform at UB pin 6.

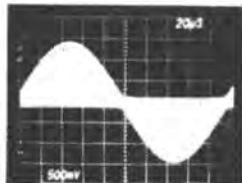

- TEST REQUIREMENTS: A. 5 kHz signal input to exciter left channel.
 B. PILOT ON/OFF switch set to ON.
- 6 DSM stereo generator output at module pin 70.

1742-81

Figure 5-2. STEREO ANALOG MODULE Waveforms

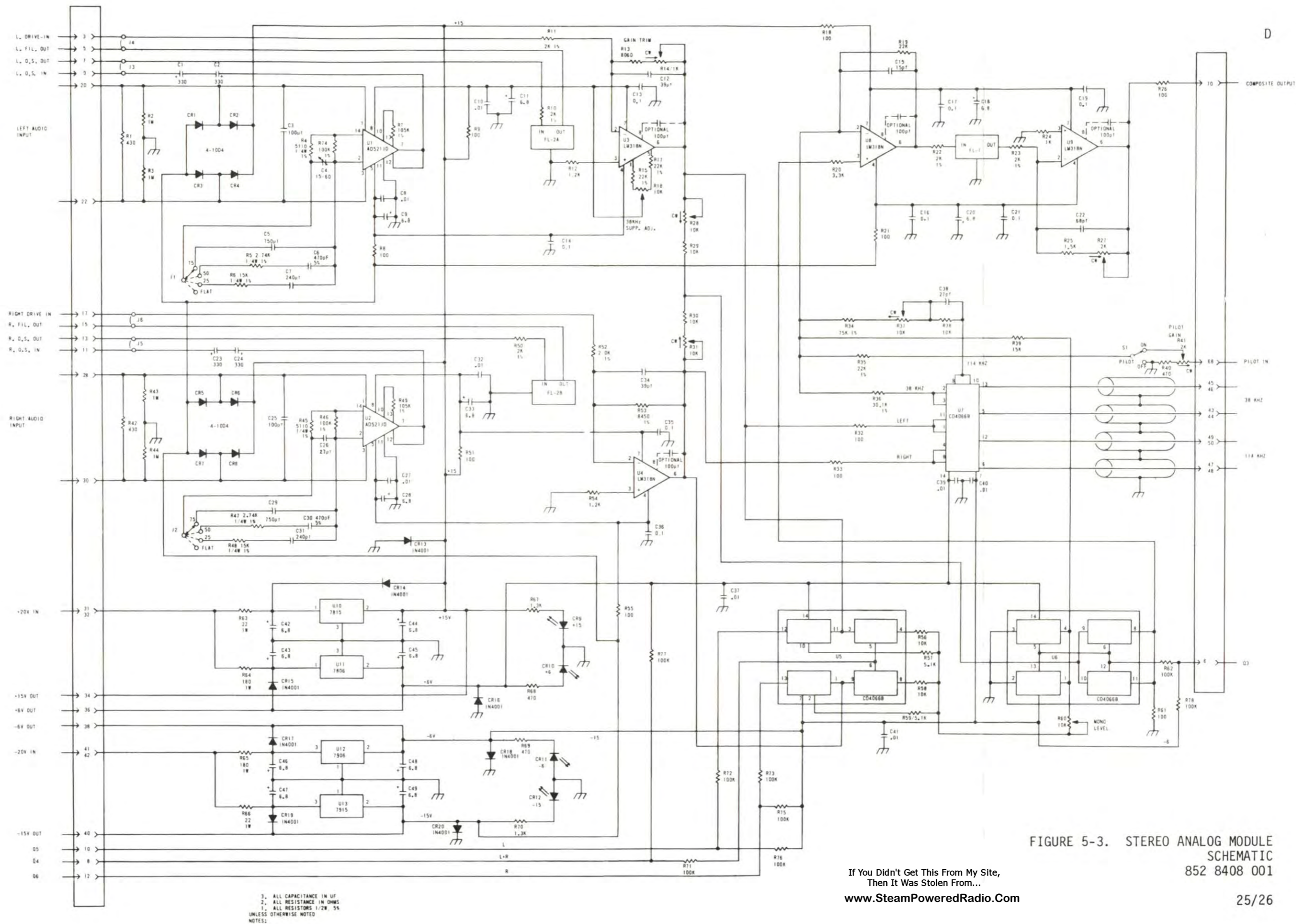

3. ALL CAPACITANCE IN UF
 2. ALL RESISTANCE IN OHMS
 1. ALL RESISTORS 1/2W, 5%
 UNLESS OTHERWISE NOTED
 NOTES:

FIGURE 5-3. STEREO ANALOG MODULE SCHEMATIC 852 8408 001

If You Didn't Get This From My Site,
 Then It Was Stolen From...
www.SteamPoweredRadio.Com

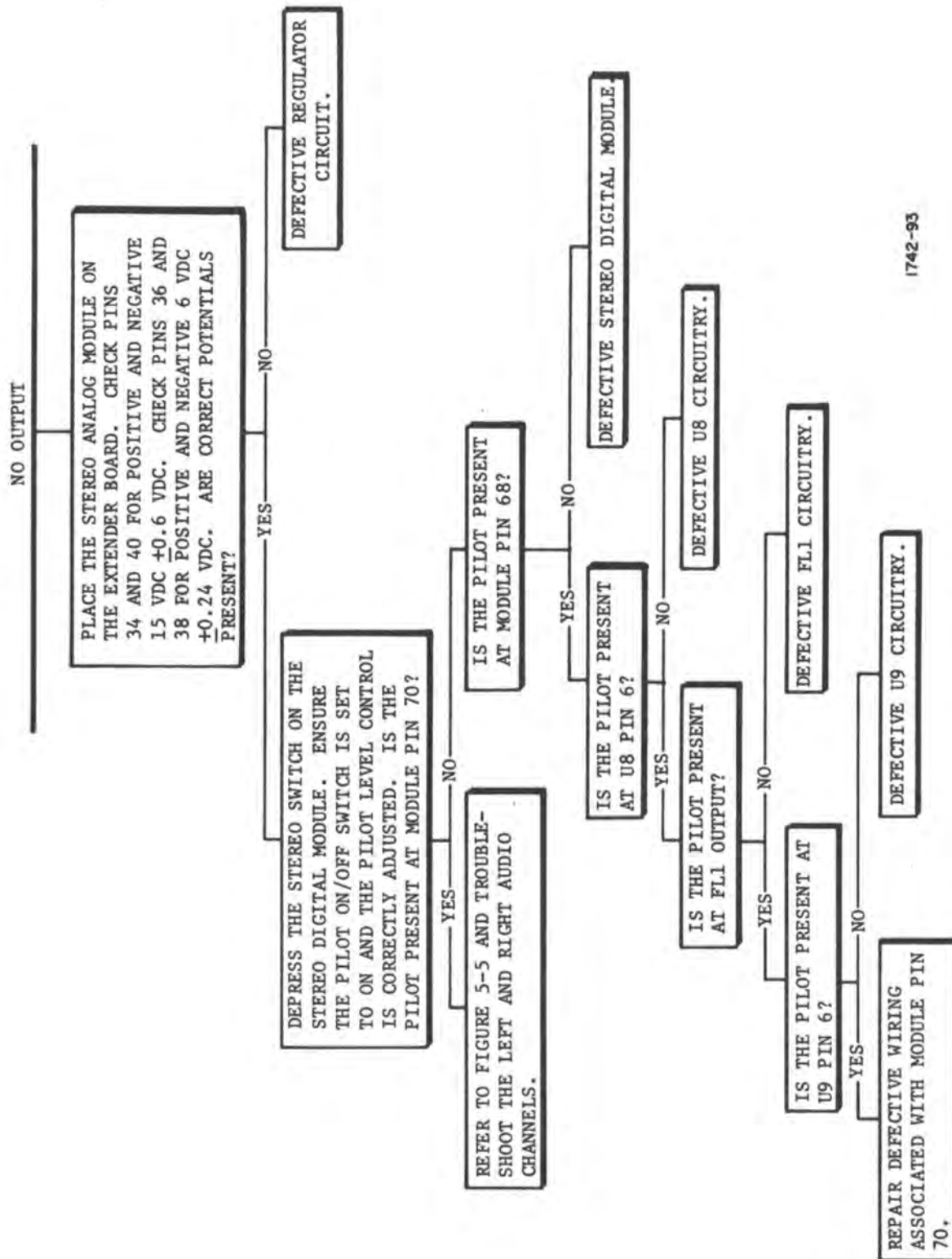

1742-93

Figure 5-4. No Output

NO AUDIO FROM LEFT AND/OR RIGHT CHANNEL (PILOT PRESENT)

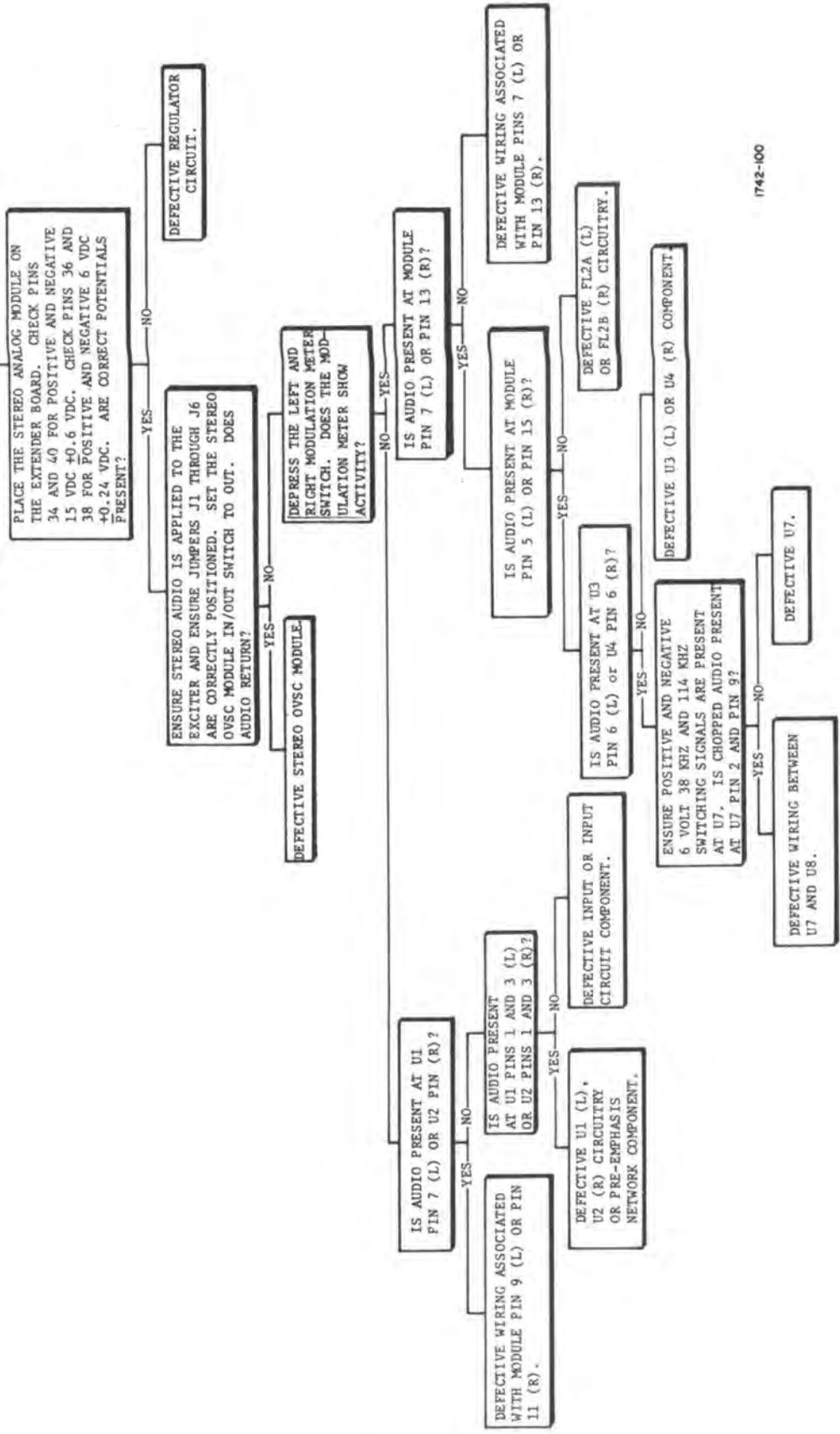

1742-100

Figure 5-5. No Audio From Left And/Or Right Channel (Pilot Present)

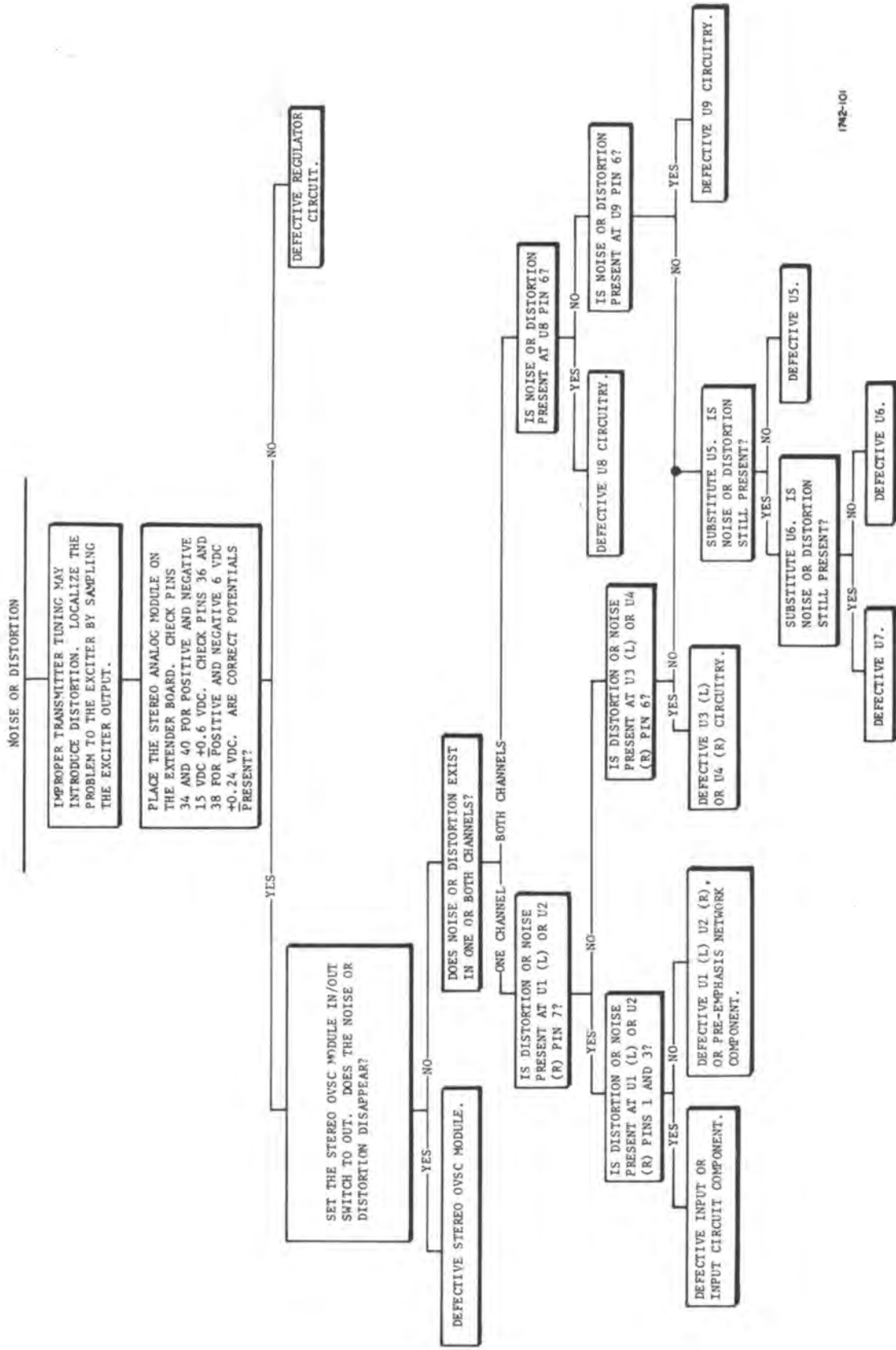

FM2-101

Figure 5-6. Noise or Distortion

POOR SEPARATION

IMPROPER TRANSMITTER TUNING MAY DEGRADE SEPARATION. LOCALIZE THE PROBLEM TO THE EXCITER BY SAMPLING THE EXCITER OUTPUT.
A MONITOR CAPABLE OF ACCURATE SEPARATION MEASUREMENTS OF 45 TO 55 DB MUST BE USED. ENSURE THE MONITOR IS NOT FREQUENCY SENSITIVE AND IS OPERATING CORRECTLY.

PLACE THE STEREO ANALOG MODULE ON THE EXTENDER BOARD. CHECK PINS 34 AND 40 FOR POSITIVE AND NEGATIVE 15 VDC +0.6 VDC. CHECK PINS 36 AND 38 FOR POSITIVE AND NEGATIVE 6 VDC +0.24 VDC. ARE CORRECT POTENTIALS PRESENT?

DEFECTIVE REGULATOR CIRCUIT.

YES — NO

IS SEPARATION (L TO R AND R TO L) UNIFORMLY APPROXIMATELY 29 DB FOR ALL FREQUENCIES?

YES — NO

CHECK U6 PINS 8 AND 11 FOR L+R COMPONENT (APPROXIMATELY 14 MILLIVOLTS FOR 100% MODULATION OF THE LEFT OR RIGHT CHANNEL). IS THE SIGNAL PRESENT?

YES — NO

DEFECTIVE U8 CIRCUITRY.

DEFECTIVE U6 CIRCUITRY.

SET THE PILOT ON/OFF SWITCH TO OFF. MODULATE ONE CHANNEL ONLY. MONITOR MODULE PIN 70 WITH AN OSCILLOSCOPE AND 1X PROBE WHICH IS FLAT IN PHASE AND AMPLITUDE THROUGH 5 MHZ. CHECK BASELINE FLATNESS AT 30 HZ AND 15 KHZ. IS THE BASELINE FLATNESS DEGRADED?

YES — NO

REFER TO FIGURE 5-2 AND ISOLATE THE PROBLEM USING THE WAVEFORMS PROVIDED

DEFECTIVE MOD OSC MODULE OR RF AMP MODULE.

1742-91

Figure 5-7. Poor Separation

POOR CROSSTALK

TO MEASURE CROSSTALK, THE STEREO OVSC MODULE IN/OUT SWITCH MUST BE SET TO OUT. MINOR VARIATIONS IN STEREO OVSC MODULE CONTROL ADJUSTMENTS WILL CAUSE THE GAIN AND/OR PHASE TO BE SLIGHTLY DIFFERENT BETWEEN THE LEFT AND RIGHT CHANNELS.

PLACE THE STEREO ANALOG MODULE ON THE EXTENDER BOARD. CHECK PINS 34 AND 40 FOR POSITIVE AND NEGATIVE 15 VDC ± 0.6 VDC. CHECK PINS 36 AND 38 FOR POSITIVE AND NEGATIVE 6 VDC ± 0.24 VDC. ARE CORRECT POTENTIALS PRESENT?

DOES THE CROSSTALK VARY WITH FREQUENCY?

DEFECTIVE REGULATOR CIRCUIT.

REFER TO TABLE 3-2 AND ADJUST THE PRE-EMPH MATCH CONTROL (C4) AND THE GAIN MATCH CONTROL (R14).
IF THE CROSS TALK IS STILL PRESENT COMPARE THE GAIN OF U1 AND U2 IN THE LEFT CHANNEL WITH THE GAIN OF U3 AND U4 IN THE RIGHT CHANNEL. THE GAIN OF EACH STAGE MUST BE IDENTICAL. REFER TO FIGURE 5-3 AND REPLACE THE AMPLIFIER BIASING COMPONENTS AS REQUIRED.

REFER TO TABLE 3-2 AND ADJUST THE GAIN MATCH CONTROL (R14).

1742-90

Figure 5-8. Poor Crosstalk

38 KHZ CARRIER ON OUTPUT

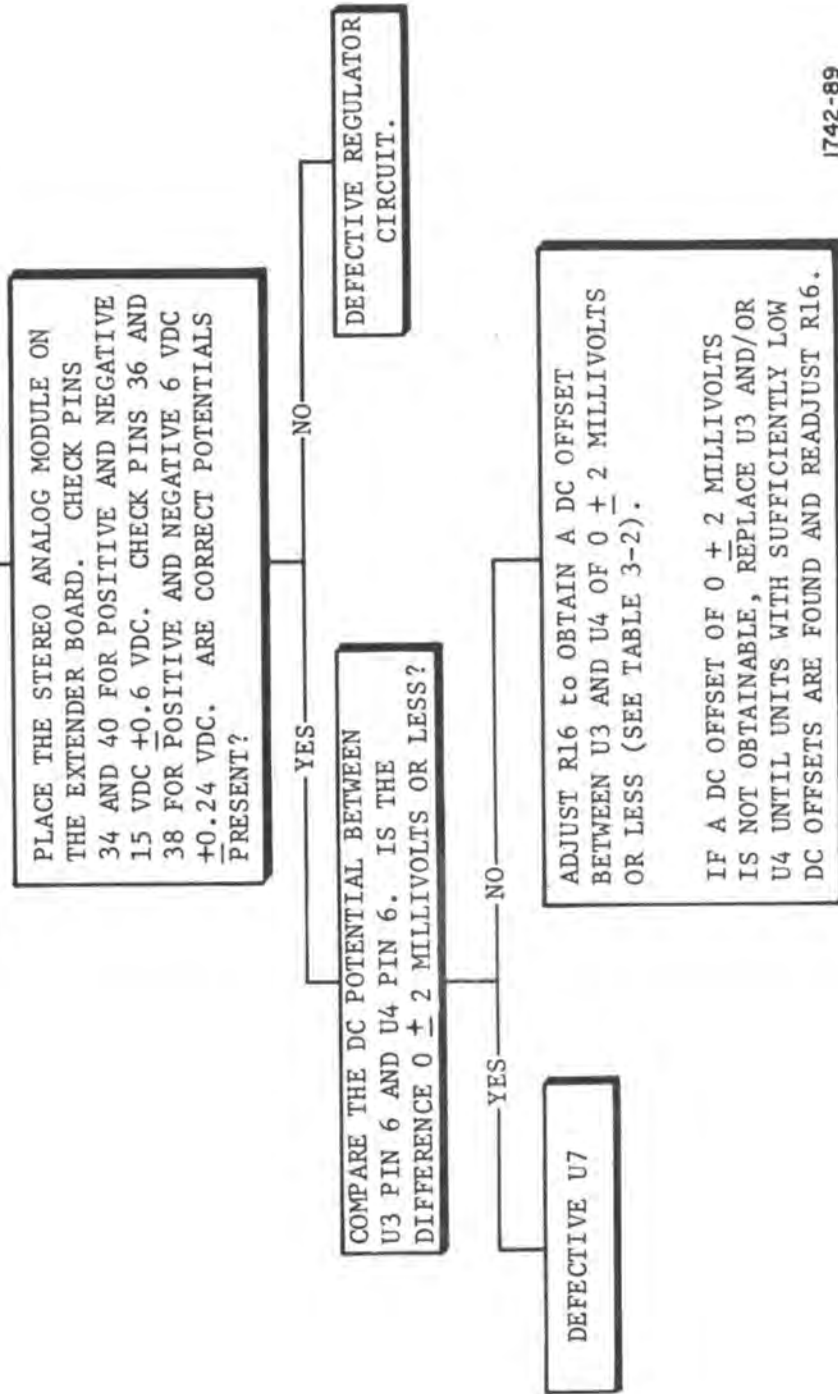

1742-89

Figure 5-9. 38 kHz Carrier on Output

SECTION VI

PARTS LIST

6-1. GENERAL

6-2. Refer to table 6-2 for replaceable parts which are required for proper maintenance of the MS-15 STEREO ANALOG MODULE. Table entries are indexed by component reference designator.

Table 6-1. STEREO ANALOG MODULE Front Panel - 994 7989 001

REF. SYMBOL	HARRIS PART NO.	DESCRIPTION	QTY.
-----	992 4902 001	STEREO ANALOG MODULE Circuit Board (Refer to table 6-2).	1

Table 6-2. STEREO ANALOG MODULE Circuit Board - 992 4902 001

REF. SYMBOL	HARRIS PART NO.	DESCRIPTION	QTY.
C1,C2	526 0045 000	Capacitor, 330 uF, 6V, 10%	2
C3	500 0759 000	Capacitor, 100 pF, Mica, 500V	1
C4	518 0054 000	Capacitor, 15-60 pF, Variable	1
C5	500 0841 000	Capacitor, 750 pF, 300V, Mica	1
C6	500 0835 000	Capacitor, 470 pF, 500V, Mica	1
C7	500 0830 000	Capacitor, 240 pF, 500V, Mica	1
C8	516 0375 000	Capacitor, 0.01 uF, 50V	1
C9	526 0049 000	Capacitor, 6.8 uF, 35V, 20%	1
C10	516 0375 000	Capacitor, 0.01 uF, 50V	1
C11	526 0049 000	Capacitor, 6.8 uF, 35V, 20%	1
C12	500 0815 000	Capacitor, 39 pF, 500V, Mica	1
C13,C14	516 0453 000	Capacitor, 0.1 uF, 100V, 20%	2
C15	500 0806 000	Capacitor, 15 pF, 500V, Mica	1
C16,C17	516 0453 000	Capacitor, 0.1 uF, 100V, 20%	2
C18	526 0049 000	Capacitor, 6.8 uF, 35V, 20%	1
C19	516 0453 000	Capacitor, 0.1 uF, 100V, 20%	1
C20	526 0049 000	Capacitor, 6.8 uF, 35V, 20%	1
C21	516 0453 000	Capacitor, 0.1 uF, 100V, 20%	1
C22	500 0821 000	Capacitor, 68 pF, 500V, Mica	1
C23,C24	526 0045 000	Capacitor, 330 uF, 6V, 10%	2
C25	500 0759 000	Capacitor, 100 pF, Mica, 500V	1
C26	500 0811 000	Capacitor, 27 pF, 500V, Mica	1

Table 6-2. STEREO ANALOG MODULE Circuit Board - 992 4902 001 (Continued)

REF. SYMBOL	HARRIS PART NO.	DESCRIPTION	QTY.
C27	516 0375 000	Capacitor, 0.01 uF, 50V	1
C28	526 0049 000	Capacitor, 6.8 uF, 35V, 20%	1
C29	500 0841 000	Capacitor, 750 pF, 300V, Mica	1
C30	500 0835 000	Capacitor, 470 pF, 500V, Mica	1
C31	500 0830 000	Capacitor, 240 pF, 500V	1
C32	516 0375 000	Capacitor, 0.01 uF, 50V	1
C33	526 0049 000	Capacitor, 6.8 uF, 35V, 20%	1
C34	500 0815 000	Capacitor, 39 pF, 500V	1
C35,C36	516 0453 000	Capacitor, 0.1 uF, 100V, 20%	2
C37	516 0375 000	Capacitor, 0.01 uF, 50V	1
C38	500 0811 000	Capacitor, 27 pF, 500V, Mica	1
C39,C40,C41	516 0375 000	Capacitor, 0.01 uF, 50V	3
C42 thru C49	526 0049 000	Capacitor, 6.8 uF, 35V, 20%	8
CR1 thru CR8	384 0284 000	Diode, 10D4/1N2070	8
CR9 thru CR12	384 0661 000	LED, Green	4
CR13 thru CR20	384 0431 000	Diode, 1N4001	8
FL1	484 0260 000	Filter, Dual Low Pass	1
FL2	484 0259 000	Filter, Low pass	1
J1 thru J6	610 0679 000	Plug, Shorting	6
R1	540 1170 000	Resistor, 430 ohm, 1/2W, 5%	1
R2,R3	540 1162 000	Resistor, 1 Megohm, 1/2W, 5%	1
R4	548 0394 000	Resistor, 5.11k ohm, 1/4W, 1%	1

Table 6-2. STEREO ANALOG MODULE Circuit Board - 992 4902 001 (Continued)

REF. SYMBOL	HARRIS PART NO.	DESCRIPTION	QTY.
R5	548 1389 000	Resistor, 2.74k ohm, 1/4W, 1%	1
R6	548 0340 000	Resistor, 15k ohm, 1/4W, 1%	1
R7	548 1370 000	Resistor, 105k ohm, 1/4W, 1%	1
R8,R9	540 1102 000	Resistor, 100 ohm, 1/2W, 5%	2
R10,R11	548 0279 000	Resistor, 2000 ohm, 1/4W, 1%	2
R12	540 1205 000	Resistor, 1200 ohm, 1/2W, 5%	1
R13	548 1396 000	Resistor, 8.06k ohm, 1/4W, 1%	1
R14	550 0398 000	Potentiometer, 1k ohm, 1/2W, 10%	1
R15	548 0366 000	Resistor, 22.1k ohm, 1/4W, 1%	1
R16	550 0922 000	Potentiometer, 10k ohm, 1/2W	1
R17	548 0366 000	Resistor, 22.1k ohm, 1/4W, 1%	1
R18	540 1102 000	Resistor, 100 ohm, 1/2W, 5%	1
R19	548 0366 000	Resistor, 22.1k ohm, 1/4W, 1%	1
R20	540 1165 000	Resistor, 3300 ohm, 1/2W, 5%	1
R21	540 1102 000	Resistor, 100 ohm, 1/2W, 5%	1
R22,R23	540 0279 000	Resistor, 2000 ohm, 1/4W, 1%	2
R24	540 1116 000	Resistor, 1000 ohm, 1/2W, 5%	1
R25	540 1129 000	Resistor, 1500 ohm, 1/2W, 5%	1
R26	540 1102 000	Resistor, 100 ohm, 1/2W, 5%	1
R27	550 0927 000	Potentiometer, 2k ohm, 1/2W, 10%	1
R28	550 0922 000	Potentiometer, 10k ohm, 1/2W	1
R29,R30	540 1111 000	Resistor, 10k ohm, 1/2W, 5%	2

Table 6-2. STEREO ANALOG MODULE Circuit Board - 992 4902 001 (Continued)

REF. SYMBOL	HARRIS PART NO.	DESCRIPTION	QTY.
R31	550 0922 000	Potentiometer, 10k ohm, 1/2W	1
R32,R33	540 1102 000	Resistor, 100 ohm, 1/2W, 5%	2
R34	548 0314 000	Resistor, 75k ohm, 1/4W, 1%	1
R35	548 0366 000	Resistor, 22.1k ohm, 1/4W, 1%	1
R36	548 0416 000	Resistor, 30.1k ohm, 1/4W, 1%	1
R37	550 0922 000	Potentiometer, 10k ohm, 1/2W	1
R38	540 1111 000	Resistor, 10k ohm, 1/2W, 5%	1
R39	540 1184 000	Resistor, 15k ohm, 1/2W, 5%	1
R40	540 1115 000	Resistor, 470 ohm, 1/2W, 5%	1
R41	550 0927 000	Potentiometer, 2k ohm, 1/2W,	1
R42	540 1170 000	Resistor, 430 ohm, 1/2W, 5%	1
R43,R44	540 1162 000	Resistor, 1 Megohm, 1/2W, 5%	2
R45	548 0394 000	Resistor, 5.11k ohm, 1/4W, 1%	1
R46	548 0932 000	Resistor, 100k ohm, 1/4W	1
R47	548 1389 000	Resistor, 2.74k ohm, 1/4W, 1%	1
R48	548 0340 000	Resistor, 15k ohm, 1/4W, 1%	1
R49	548 1370 000	Resistor, 105k ohm, 1/4W, 1%	1
R50	548 0279 000	Resistor, 2000 ohm, 1/4W, 1%	1
R51	540 1102 000	Resistor, 100 ohm, 1/2W, 5%	1
R52	548 0279 000	Resistor, 2000 ohm, 1/4W, 1%	1
R53	548 1360 000	Resistor, 8450 ohm, 1/4W, 1%	1
R54	540 1205 000	Resistor, 1200 ohm, 1/2W, 5%	1

Table 6-2. STEREO ANALOG MODULE Circuit Board - 992 4902 001 (Continued)

REF. SYMBOL	HARRIS PART NO.	DESCRIPTION	QTY.
R55	540 1102 000	Resistor, 100 ohm, 1/2W, 5%	1
R56	540 1111 000	Resistor, 10k ohm, 1/2W, 5%	1
R57	540 1105 000	Resistor, 5100 ohm, 1/2W, 5%	1
R58	540 1111 000	Resistor, 10k ohm, 1/2W, 5%	1
R59	540 1105 000	Resistor, 5100 ohm, 1/2W, 5%	1
R60	550 0922 000	Potentiometer, 10k ohm, 1/2W	1
R61	540 1102 000	Resistor, 100 ohm, 1/2W, 5%	1
R62	540 1159 000	Resistor, 100k ohm, 1/2W, 5%	1
R63	540 0292 000	Resistor, 22 ohm, 1W, 5%	1
R64,R65	540 0314 000	Resistor, 180 ohm, 1W, 5%	2
R66	540 0292 000	Resistor, 22 ohm, 1W, 5%	1
R67	540 1187 000	Resistor, 1300 ohm, 1/2W, 5%	1
R68,R69	540 1115 000	Resistor, 470 ohm, 1/2W, 5%	2
R70	540 1187 000	Resistor, 1300 ohm, 1/2W, 5%	1
R71 thru R73	540 1159 000	Resistor, 100k ohm, 1/2W, 5%	3
R74	548 0932 000	Resistor, 100k ohm, 1/4W, 1%	1
R75 thru R78	540 1159 000	Resistor, 100k ohm, 1/2W, 5%	4
S1	604 0859 000	Switch, Toggle, DPDT	1
U1,U2	382 0473 000	Integrated Circuit, AD521JD	2
U3,U4	382 0472 000	Integrated Circuit, LM318N	2
U5,U6,U7	382 0523 000	Integrated Circuit, MC14066BCP	3
U8,U9	382 0472 000	Integrated Circuit, LM318N	2

Table 6-2. STEREO ANALOG MODULE Circuit Board - 992 4902 001 (Continued)

REF. SYMBOL	HARRIS PART NO.	DESCRIPTION	QTY.
U10	382 0359 000	Integrated Circuit, MC7815CP	1
U11	382 0471 000	Integrated Circuit, MC7806CT	1
U12	382 0470 000	Integrated Circuit, MC7906CT	1
U13	382 0360 000	Integrated Circuit, MC7915CP	1
XU1,XU2	404 0674 000	Socket, IC, 14 Contact	2
XU3,XU4	404 0673 000	Socket, IC, 8 Contact	2
XU5 thru XU7	404 0674 000	Socket, IC, 14 Contact	3
XU8,XU9	404 0673 000	Socket, IC, 8 Contact	2
	404 0513 000	Heat Sink, PA1-1CB	2
	410 0344 000	Insulator, Kapton	4
	612 0901 000	Jack, Printed Circuit Mount	28
	843 1603 00	Printed Board	1

TECHNICAL MANUAL

STEREO OVSC MODULE

994 7991 001



HARRIS CORPORATION

Broadcast Products Division

T.M. No. 888 1742 006

Printed: October 1977
Revision A: April 1980
Revision E: March 1981
Revision F: June 1981

WARNING

THE CURRENTS AND VOLTAGES IN THIS EQUIPMENT ARE DANGEROUS. PERSONNEL MUST AT ALL TIMES OBSERVE SAFETY REGULATIONS.

This manual is intended as a general guide for trained and qualified personnel who are aware of the dangers inherent in handling potentially hazardous electrical/electronic circuits. It is not intended to contain a complete statement of all safety precautions which should be observed by personnel in using this or other electronic equipment.

The installation, operation, maintenance and service of this equipment involves risks both to personnel and equipment, and must be performed only by qualified personnel exercising due care. HARRIS CORPORATION shall not be responsible for injury or damage resulting from improper procedures or from the use of improperly trained or inexperienced personnel performing such tasks.

During installation and operation of this equipment, local building codes and fire protection standards must be observed. The following National Fire Protection Association (NFPA) standards are recommended as references:

- Automatic Fire Detectors, No. 72E
- Installation, Maintenance, and Use of Portable Fire Extinguishers, No. 10
- Halogenated Fire Extinguishing Agent Systems, No. 12A

WARNING

ALWAYS DISCONNECT POWER BEFORE OPENING COVERS, DOORS, ENCLOSURES, GATES, PANELS OR SHIELDS. ALWAYS USE GROUNDING STICKS AND SHORT OUT HIGH VOLTAGE POINTS BEFORE SERVICING. NEVER MAKE INTERNAL ADJUSTMENTS, PERFORM MAINTENANCE OR SERVICE WHEN ALONE OR WHEN FATIGUED.

Do not remove, short-circuit or tamper with interlock switches on access covers, doors, enclosures, gates, panels or shields. Keep away from live circuits, know your equipment and don't take chances.

WARNING

IN CASE OF EMERGENCY ENSURE THAT POWER HAS BEEN DISCONNECTED.

Treatment of Electrical Shock

1. If victim is not responsive follow the A-B-Cs of basic life support.

PLACE VICTIM FLAT ON HIS BACK ON A HARD SURFACE

A AIRWAY

IF UNCONSCIOUS,
OPEN AIRWAY

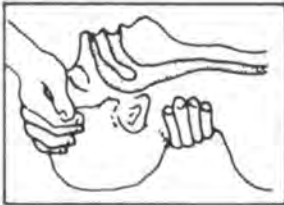

LIFT UP NECK
PUSH FOREHEAD BACK
CLEAR OUT MOUTH IF NECESSARY
OBSERVE FOR BREATHING

B BREATHING

IF NOT BREATHING,
BEGIN ARTIFICIAL
BREATHING



TILT HEAD
PINCH NOSTRILS
MAKE AIRTIGHT SEAL

4 QUICK FULL BREATHS

REMEMBER MOUTH TO MOUTH RESUSCITATION
MUST BE COMMENCED AS SOON AS POSSIBLE

CHECK CAROTID PULSE



IF PULSE ABSENT,
BEGIN ARTIFICIAL
CIRCULATION

C CIRCULATION

DEPRESS STERNUM 1 1/2" TO 2"

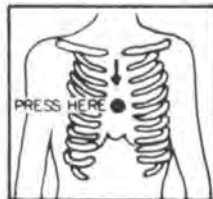

APPROX. { ONE RESCUER
80 SEC. { 15 COMPRESSIONS
2 QUICK BREATHS

APPROX. { TWO RESCUERS
60 SEC. { 5 COMPRESSIONS
1 BREATH



NOTE: DO NOT INTERRUPT RHYTHM OF COMPRESSIONS
WHEN SECOND PERSON IS GIVING BREATH

Call for medical assistance as soon as possible.

2. If victim is responsive.

- a. keep them warm
- b. keep them as quiet as possible
- c. loosen their clothing
(a reclining position is recommended)

FIRST-AID

Personnel engaged in the installation, operation, maintenance or servicing of this equipment are urged to become familiar with first-aid theory and practices. The following information is not intended to be complete first-aid procedures, it is brief and is only to be used as a reference. It is the duty of all personnel using the equipment to be prepared to give adequate Emergency First Aid and thereby prevent avoidable loss of life.

Treatment of Electrical Burns

1. Extensive burned and broken skin
 - a. Cover area with clean sheet or cloth. (Cleanest available cloth article.)
 - b. Do not break blisters, remove tissue, remove adhered particles of clothing, or apply any salve or ointment.
 - c. Treat victim for shock as required.
 - d. Arrange transportation to a hospital as quickly as possible.
 - e. If arms or legs are affected keep them elevated.

NOTE

If medical help will not be available within an hour and the victim is conscious and not vomiting, give him a weak solution of salt and soda: 1 level teaspoonful of salt and 1/2 level teaspoonful of baking soda to each quart of water (neither hot or cold). Allow victim to sip slowly about 4 ounces (a half of glass) over a period of 15 minutes. Discontinue fluid if vomiting occurs. (Do not give alcohol.)

2. Less severe burns - (1st & 2nd degree)
 - a. Apply cool (not ice cold) compresses using the cleanest available cloth article.
 - b. Do not break blisters, remove tissue, remove adhered particles of clothing, or apply salve or ointment.
 - c. Apply clean dry dressing if necessary.
 - d. Treat victim for shock as required.
 - e. Arrange transportation to a hospital as quickly as possible.
 - f. If arms or legs are affected keep them elevated.

REFERENCE: ILLINOIS HEART ASSOCIATION

AMERICAN RED CROSS STANDARD FIRST AID AND PERSONAL SAFETY MANUAL
(SECOND EDITION)

TABLE OF CONTENTS

<u>Paragraph</u>		<u>Page</u>
SECTION I. GENERAL DESCRIPTION		
1-1.	Equipment Purpose	1
1-3.	Technical Characteristics	1
SECTION II. INSTALLATION		
2-1.	General	1
SECTION III. CONTROLS AND INDICATORS		
3-1.	General	1
SECTION IV. PRINCIPLES OF OPERATION		
4-1.	Circuit Description	8
4-2.	General Information	8
4-6.	Module Set Up	8
4-15.	Simplified Description	10
4-21.	Detailed Description	10
4-23.	Input Circuit	11
4-24.	Threshold Clipper	11
4-25.	All-Pass/Low-Pass Filters	11
4-26.	Clipper	11
4-27.	Indicators	11
4-29.	Power	15
SECTION V. MAINTENANCE		
5-1.	Corrective Maintenance	15
5-3.	Troubleshooting	15
SECTION VI. PARTS LIST		
6-1.	General	31

LIST OF TABLES

<u>Table</u>	<u>Page</u>
1-1. Technical Characteristics	2
3-1. STEREO OVSC MODULE Controls and Indicators	4
3-2. Control Adjustments	5
5-1. STEREO OVSC MODULE Fault Isolation Index	16
5-2. STEREO OVSC MODULE Parts Index	18
6-1. STEREO OVSC MODULE Front Panel	32
6-2. STEREO OVSC MODULE Circuit Board	33

LIST OF ILLUSTRATIONS

<u>Figure</u>	<u>Page</u>
3-1. STEREO OVSC MODULE	3
4-1. STEREO OVSC MODULE Simplified Block Diagram	12
4-2. STEREO OVSC MODULE Detailed Block Diagram	13
5-1. STEREO OVSC MODULE Parts Layout	17
5-2. STEREO OVSC MODULE Waveforms	20
5-3. STEREO OVSC MODULE Schematic	21
5-4. Overshoots	23
5-5. Distortion	24
5-6. Noise	25
5-7. Unable to Set Compensation Threshold	27
5-8. Excessive Harmonic Content	28
5-9. Left or Right Indicators Inoperative	29
5-10. No Output	30

SECTION I

GENERAL DESCRIPTION

1-1. EQUIPMENT PURPOSE

1-2. The STEREO OVSC MODULE provides a special filtering process which operates independently of limiters or stereophonic generators to limit the overshoot on FM stereophonic or future quadraphonic transmission to two percent maximum on any input program material processed by any limiter. Typically, a two to six dB increase in loudness can be achieved due to elimination of overshoot with no other audible effect, which allows high signal levels to be maintained without degrading signal quality. Low-pass filters prevent audio interference with the 19 kHz pilot signal and eliminate interference between the L+R signals. The filters are transparent to audio within ± 0.5 dB of the passband of 30 Hz to 15 kHz and provide 60 dB of attenuation at 19 kHz and above. Indicators on the module front panel and outputs to the AC meter module aid in level setup and provide overshoot limiting indications during operation.

1-3. TECHNICAL CHARACTERISTICS

1-4. Table 1-1 lists operating characteristics and parameters of the MS-15 STEREO OVSC MODULE.

SECTION II

INSTALLATION

2-1. GENERAL

2-2. Refer to 888-1742-001, MS-15 FM Exciter, Section II, Installation.

SECTION III

CONTROLS AND INDICATORS

3-1. GENERAL

3-2. Figure 3-1 shows the location of each control or indicator associated with the MS-15 STEREO OVSC MODULE and table 3-1 lists the controls and indicators with a description of each item listed. Control setup adjustments are listed in table 3-2.

Table 1-1. Technical Characteristics

FUNCTION	CHARACTERISTIC
<p><u>INPUTS</u></p> <p>POWER:</p> <p>SIGNAL:</p> <p>LEFT AND RIGHT CHANNEL AUDIO</p> <p><u>OUTPUTS</u></p> <p>OVERSHOOT COMPENSATION (METERING)</p> <p>LEFT AND RIGHT CHANNEL OVERSHOOT COMPENSATED AUDIO</p>	<p>+20 Vdc @ 0.100 amperes. -20 Vdc @ 0.120 amperes.</p> <p>Pre-emphasized 1.41 Volts Peak for 100% modulation.</p> <p>5.36 Volts Peak indicates 100% overshoot.</p> <p>DTR low-pass filtered 0.707 Volts Peak for 100% modulation.</p>

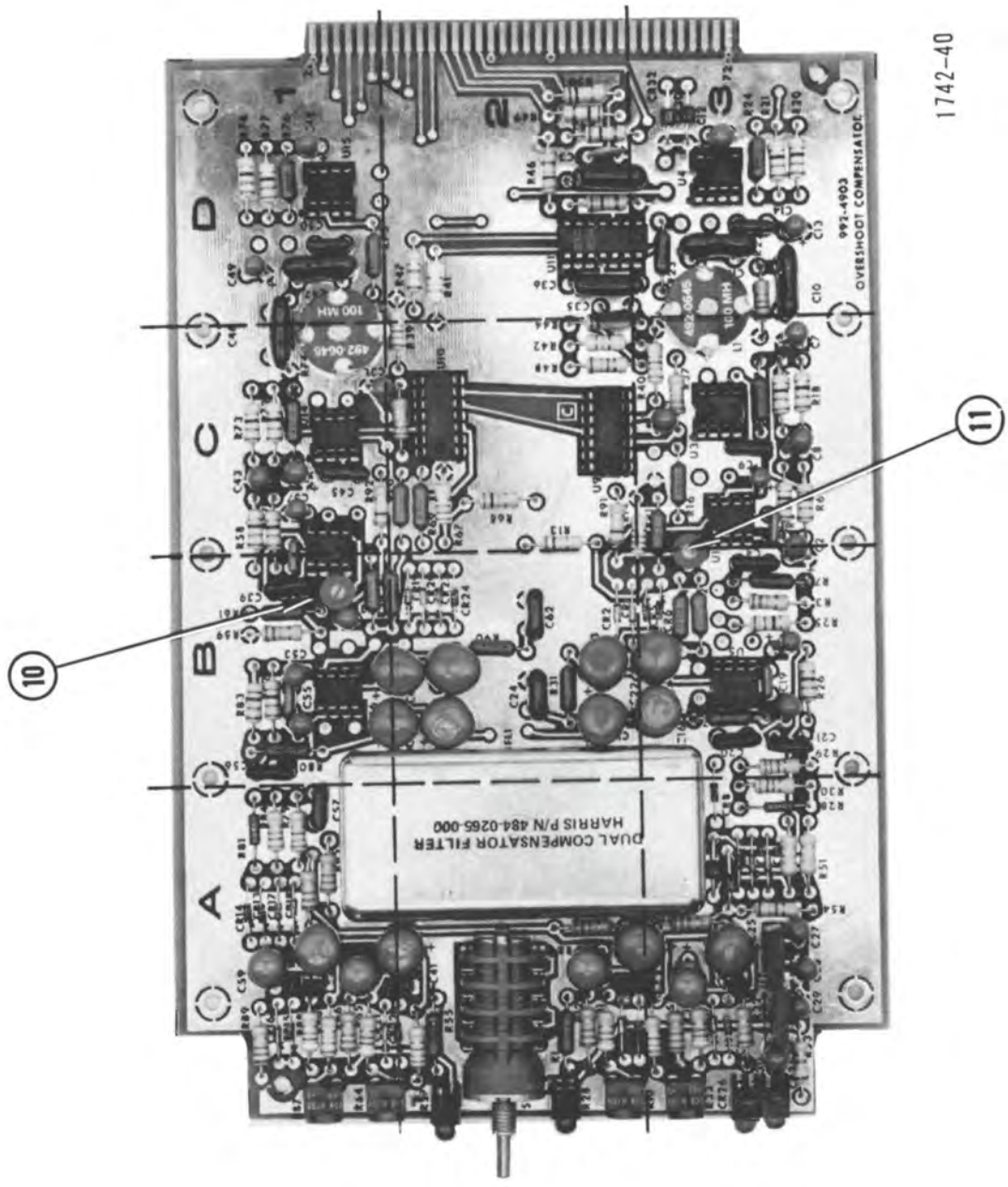

1742-40

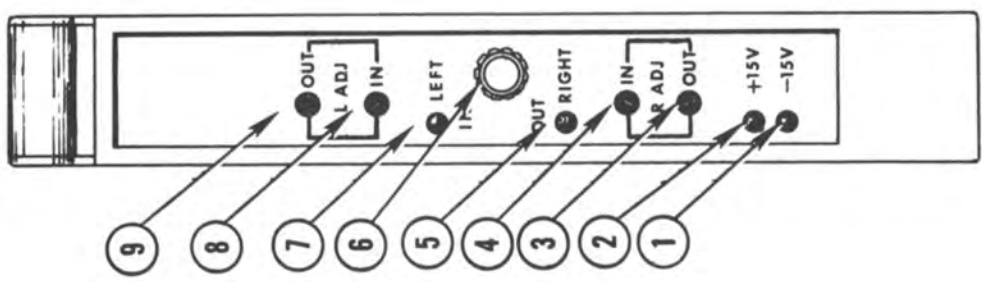

Figure 3-1. STEREO OVSC MODULE

Table 3-1. STEREO OVSC MODULE Controls and Indicators

REF.	CONTROL/INDICATOR	FUNCTION
1	-15V Indicator (CR25)	Illuminates to indicate the STEREO OVSC module -15 volt regulator is operational.
2	+15V Indicator (CR26)	Illuminates to indicate the STEREO OVSC module +15 volt regulator is operational.
3	R ADJ OUT Control (R33)	Adjusts the right channel output threshold from the STEREO OVSC MODULE.
4	R ADJ IN Control (R10)	Adjusts the right channel input threshold to the STEREO OVSC MODULE.
5	RIGHT Indicator (CR28)	Indicates operation of the right channel overshoot control circuitry when illuminated.
6	IN/OUT Switch (S1)	IN position: Enables operation of the DTR filter. OUT position: Enables the conventional low-pass filter.
7	LEFT Indicator (CR27)	Indicates operation of the left channel overshoot control circuitry when illuminated.
8	L ADJ IN Control (R64)	Adjusts the left channel input threshold to the STEREO OVSC MODULE.
9	L ADJ OUT Control (R87)	Adjusts the left channel output threshold from the STEREO OVSC MODULE.
10	Left Channel Pre-amplifier Offset Adjust (R94)	Adjusts DC voltage offset of left channel preamplifier.
11	Right Channel Pre-amplifier Offset Adjust (R93)	Adjusts DC voltage offset of right channel preamplifier.

Table 3-2. Control Adjustments

CONTROL	ADJUSTMENT
<p>L ADJ OUT Control (R87) L ADJ IN Control (R64) R ADJ OUT Control (R33) R ADJ IN Control (R10)</p>	<p>Adjustment of the DTR filter consists of setting internal compensation thresholds to a level corresponding to 100% total modulation as follows:</p> <ol style="list-style-type: none"> 1. Set the STEREO OVSC MODULE IN/OUT switch to IN. 2. Adjust all four STEREO OVSC MODULE front panel controls to the maximum clockwise position. These controls are four turn potentiometers without stops at the end of their range. 3. Depress the STEREO DIGITAL module STEREO switch. The STEREO indicator will illuminate. 4. Depress the SCA 1 and SCA 2 module(s) OFF switch(es). Each SCA module OFF indicator will illuminate. 5. Disconnect the left and right stereo inputs from the LEFT FRONT (+) and (-) and RIGHT FRONT (+) and (-) connections on the rear of the exciter (Tb1 terminals 1 and 3, 4 and 6). 6. Apply a 400 Hz sinusoidal signal at +10 dBm into the left channel only at Tb1 terminals 1 and 3. 7. Depress the B BAND MODULATION meter switch. 8. Adjust the sinusoidal signal level until the MODULATION meter indicates 97% total modulation.

Table 3-2. Control Adjustments (Continued)

CONTROL	ADJUSTMENT
	<ol style="list-style-type: none"> <li data-bbox="801 399 1381 617">9. Depress the LEFT MODULATION meter switch. The MODULATION meter will indicate 100%. The apparent 3% discrepancy is due to the normal phase relationships between the pilot and the 38 kHz DSB signal. <li data-bbox="801 654 1381 841">10. Adjust the STEREO OVSC MODULE L ADJ OUT control counterclockwise until the LEFT indicator illuminates. Adjust the control clockwise until the indicator just goes out. <li data-bbox="801 878 1381 1002">11. Adjust the STEREO OVSC MODULE L ADJ IN control counterclockwise until the indicator just goes out. <li data-bbox="801 1040 1381 1133">12. Disconnect the 400 Hz sinusoidal signal from the left channel. <li data-bbox="801 1170 1381 1295">13. Apply the 400 Hz sinusoidal signal at +10 dBm into the right channel only at TBI, terminals 4 and 6. <li data-bbox="801 1332 1381 1384">14. Depress the B BAND MODULATION meter switch. <li data-bbox="801 1421 1381 1514">15. Adjust the sinusoidal signal until the MODULATION METER indicates 97% total modulation. <li data-bbox="801 1551 1381 1769">16. Depress the RIGHT MODULATION meter switch. The MODULATION meter will indicate 100%. The apparent 3% discrepancy is due to the normal phase relationships between the pilot and the 38 kHz DSB signal.

Table 3-2. Control Adjustments (Continued)

CONTROL	ADJUSTMENT
<p>Left Channel Preamplifier Offset Adjust (R94)</p> <p>Right Channel Preamplifier Offset Adjust (R93)</p>	<ol style="list-style-type: none"> 17. Adjust the STEREO OVSC MODULE R ADJ OUT control counterclockwise until the RIGHT indicator illuminates. Adjust the control clockwise until the indicator just goes out. 18. Adjust the STEREO OVSC MODULE R ADJ IN control counterclockwise until the RIGHT indicator illuminates. Adjust the control clockwise until the indicator just goes out. 19. Disconnect the 400 Hz sinusoidal signal from the right channel input and reconnect the audio inputs to the left and right channels. 1. Remove the module from the exciter and remove the side cover. 2. Mount the module in the exciter using the extender board provided with the exciter. 3. Connect a DC millivoltmeter to pin 6 of U12 in the left channel or U1 in the right channel. 4. Adjust R94 in the left channel or R93 in the right channel to obtain a DC indication of $0 \text{ Vdc} \pm 0.01 \text{ Vdc}$. 5. Disconnect the millivoltmeter from the module, remove the extender board, replace the module side cover, and replace the module in the exciter.

SECTION IV

PRINCIPLES OF OPERATION

4-1. CIRCUIT DESCRIPTION

4-2. GENERAL INFORMATION

4-3. The STEREO OVSC (overshoot compensator) module provides 15 kHz low-pass filtering of the left and right channel audio signals prior to modulation of the carrier to prevent interference with the 19 kHz pilot and to eliminate interference between the L+R and L-R signals. Low-pass filtering allows high dynamic separation and eliminates the raspy noises characteristic of harmonic interference between L+R and L-R.

4-4. Overshoot is usually caused by the effect of low-pass filtering the audio to remove signals above 15 kHz. A conventional low-pass filter changes two independent characteristics of the input signal. In addition to changing the amplitude response versus frequency, the filter also changes the phase relationships among different frequencies within the filter pass-band.

4-5. Although the pre-emphasized output of most FM limiters is accurately amplitude-limited, this is not necessarily true after the limiter output has been low-pass filtered. The filter output may ring and overshoot above 100% modulation even though the input is constrained to 100%. The overshoot is due to (1) elimination of harmonics which serve to reduce peak amplitude, and (2) non-uniform time delay (nonlinear phase) which rearranges signal components in time such that new peaks result. The MS-15 Dynamic Transient Response (DTR) filter low-pass filters the limiter output with no more than two percent overshoot, allowing high modulation levels to be maintained with no loss of audio quality.

4-6. MODULE SET UP

4-7. The audio signal input to the exciter should be processed by an FM type peak limiter, that is, a limiter with pre-emphasis protection. Use of an AM limiter or no limiter at all after pre-emphasis will result in the input signals exceeding certain module internal overshoot sensing thresholds. If normal audio exceeds these thresholds, the module will assume the signal to be overshoot and limiting and distortion will result. If the audio input is correctly limited, only overshoots will exceed the internal thresholds producing limiting which will not result in distortion. Refer to "A New Filtering Process for Optimal Overshoot Control" in Appendix A.

4-8. Because the DTR filter presupposes that the input audio signal has been properly amplitude limited to exactly 100% modulation, it is important to ensure that audio levels from the limiter to the exciter are exact. This is considerably more important with the MS-15 than with conventional exciters. If the limiter output is applied to the exciter at 80% modulation, the DTR filter will eliminate overshoots above 100% but will allow overshoots to extend from 80% to 100% modulation. In this case the modulation

meter will show that 100% modulation is being maintained when in fact it is only overshoots that are reaching 100% with program material peaks remaining at 80% modulation. On the other hand, if the limiter is driving the exciter at a level corresponding to 120% modulation, the DTR filter thresholds will assume that normal program peaks are overshoots, and severe distortion will result. For optimum loudness with no degradation of audio quality, the output from the limiter to the exciter audio inputs should be maintained at exactly 100%.

4-9. When the DTR filter is in use, special care must be observed so that the exciter audio inputs are not even slightly overdriven. This may be checked by depressing the LEFT and RIGHT MODULATION switches and noting the level indicated by the MODULATION meter. The output of the FM limiter should be adjusted to the 100% level on the MODULATION meter.

4-10. Due to the unconventional DTR technique, if it is desired to increase modulation, the output level of the FM limiter should not be increased. The STEREO OVSC MODULE will assume the increase is overshoot and limit the signal accordingly. This will result in distortion but no increase in modulation. To increase modulation, the STEREO ANALOG module COMP LEVEL control should be adjusted.

4-11. Normally the STEREO OVSC MODULE and the STEREO ANALOG module will be used together in which case the STEREO ANALOG module low-pass filters are used in the DTR filtering process. The STEREO OVSC MODULE IN/OUT switch is provided to bypass the overshoot control circuits and provide conventional low-pass filtering if desired.

4-12. Some FM limiters contain low-pass filters and/or notch filters at their outputs. When such a limiter is used with the MS-15 exciter there is not only a duplication of circuitry, but the filters in the limiter will overshoot, making the limiter less effective. For maximum modulation without filter overshoot, the internal low-pass filters of these FM limiters should be disabled. In most cases this will be a simple reversible operation.

4-13. The DTR filter must be disabled to measure crosstalk as the gain and phase of the filter is not exactly the same between channels. The difference in gain and phase will affect crosstalk, but not separation. Reasonable crosstalk measurements will be obtained using the DTR filter. However, stated performance will be guaranteed only in the conventional filter mode with the IN/OUT switch set to OUT.

4-14. Since some FM limiters have finite attack times and/or non-uniform limiting characteristics, it is preferable to set up limiter levels with actual programming rather than with test tones. Steady-state test tones do not take into account attack times. Nor do they check limiting level at any more than one frequency at a time. Therefore, it is advisable to select musical programming with a wide spectral distribution as a test signal. With programming applied to the limiters at a level sufficiently high such that they are in limiting, simply adjust the left and right audio output levels of the limiters such that the LEFT and RIGHT meter positions on the exciter indicate 100% modulation on peaks.

4-15. SIMPLIFIED DESCRIPTION

4-16. The DTR filter comprises two low-pass filters, an all-pass filter, an input threshold clipper, and an output level clipper. A block diagram is provided in figure 4-1.

4-17. The first filter has a cutoff frequency of 15 kHz. The second filter has a cutoff frequency of 17.5 kHz and is preceded by an all-pass filter which linearizes the signal phase from DC to the cutoff frequency of the first filter (15 kHz). The combination of the all-pass filter and the second low-pass filter presents a uniform time delay of approximately 100 microseconds between DC and 15 kHz. Since the passband of the first filter is contained within the linear phase passband of the second filter, the second filter changes neither the phase nor amplitude relationships of the first output but adds only time delay.

4-18. If the first low-pass filter overshoots, the second low-pass filter will overshoot 100 microseconds later. The inverse is also true: if the first filter does not overshoot, the second filter will not overshoot. The overshoot is controlled by the threshold clipper which passes only peaks which exceed 100% modulation (overshoots). The operation of a threshold clipper is the inverse of a conventional clipper. As a conventional clipper prevents the signal amplitude from exceeding a certain level, a threshold clipper will not pass a signal unless the signal amplitude exceeds a certain level. Then, only the portion of the signal which exceeds the threshold will be output and therefore may be used to separate overshoots from the signal level. In the MS-15, overshoots from the threshold clipper are algebraically subtracted from the 15 kHz filter output in a sum amplifier to effectively cancel overshoots applied to the all-pass filter.

4-19. The output of the all-pass filter loops out of the STEREO OVSC MODULE through the STEREO ANALOG module 17.5 kHz low-pass filters and back to the STEREO OVSC MODULE. Due to several approximations in the filtering process, the second filter will occasionally overshoot a few percent, however clipping the remaining overshoots will produce negligible harmonic components. The filtered audio is routed through the output clipper which passes levels corresponding to modulation levels of less than 100% only. The filtered overshoot compensated audio is then output to the STEREO ANALOG module.

4-20. Comparators across the clipping diodes sense whenever overshoot correction occurs. The comparator outputs are wire-OR'ed and drive a one shot timer which illuminates the LEFT or RIGHT LEDs to provide a visual indication of overshoot correction.

4-21. DETAILED DESCRIPTION

4-22. As the operation of the left and right channels is identical, only the left channel will be referenced in the detailed description. Refer to the detailed block diagram (figure 4-2) and the schematic diagram (figure 5-3) for the following discussion.

4-23. INPUT CIRCUIT. Audio is input from the STEREO ANALOG module through contacts of the STEREO OVSC MODULE IN/OUT switch (S1). The switch bypasses the overshoot control circuitry and provides conventional low-pass filtering if desired. The audio is fed through a 15 kHz low-pass filter (FL-1B) and drives audio preamplifier (U12). Control R94 provides a preamplifier DC offset adjustment.

4-24. THRESHOLD CLIPPER. The output of preamplifier U12 is applied to a threshold clipper containing an active programming zener diode (U2). The L ADJ IN control (R64) adjusts the zener voltage to the peak voltage level corresponding to 100% modulation minus the voltage drops across temperature compensating diodes CR21 and CR22 so that the threshold clipper will pass only overshoots. The overshoots are output from the junction of diodes CR23 and CR24 to the AC meter circuits and the inverting input of sum amplifier U14. Audio from the low-pass filter (FL-1B) is summed with the audio overshoots from the threshold clipper at the input to amplifier U14. Because U12 inverts the signal, the overshoots are also inverted and are therefore subtracted from the filter output by summing amplifier U14.

4-25. ALL-PASS/LOW-PASS FILTERS. Audio from summer U14 is applied to all-pass filter U15. The all-pass filter (phase equalizer) is flat in frequency response but produces a phase shift dependent upon frequency. The signal is looped out of the STEREO OVSC MODULE, through 17.5 kHz low-pass filter FL-2A in the STEREO Analog module, and back to the STEREO OVSC MODULE. The overall response of the all-pass and low-pass filter characteristics combine to yield a linear phase low-pass characteristic.

4-26. CLIPPER. The output of the 17.5 kHz filter drives amplifier U16 and a threshold clipper which contains an active programmable zener diode (U17). The L ADJ OUT control (R87) adjusts the zener voltage to the peak voltage level corresponding to 100% modulation minus the voltage drop across temperature compensating diodes CR15 and CR16. Because the threshold clipper is in the feed back path of U16, all overshoots exceeding 100% modulation will be clipped. The clipper output level is established by resistor R31, capacitor C24, and a terminating resistance in the STEREO ANALOG module input circuit.

4-27. INDICATORS. Overshoots from each threshold clipper are output to the peak reading meter circuits. The meter provides a visual indication of the amount of filter overshoot which is being corrected within the entire module.

4-28. The LEFT and RIGHT light emitting diodes indicate how often overshoot control is occurring in each channel. Quad comparator U10 monitors the voltage across clipping diodes CR23, CR24, CR13 and CR14 in the left channel. Whenever any of these diodes conduct, the associated comparator turns on and allows dual timer U11 to begin a short (11 millisecond) timing cycle which illuminates CR27 for a sufficiently long time to provide a visual indication of overshoot control. Test points are provided at both outputs from the dual timer to check the indicator drive.

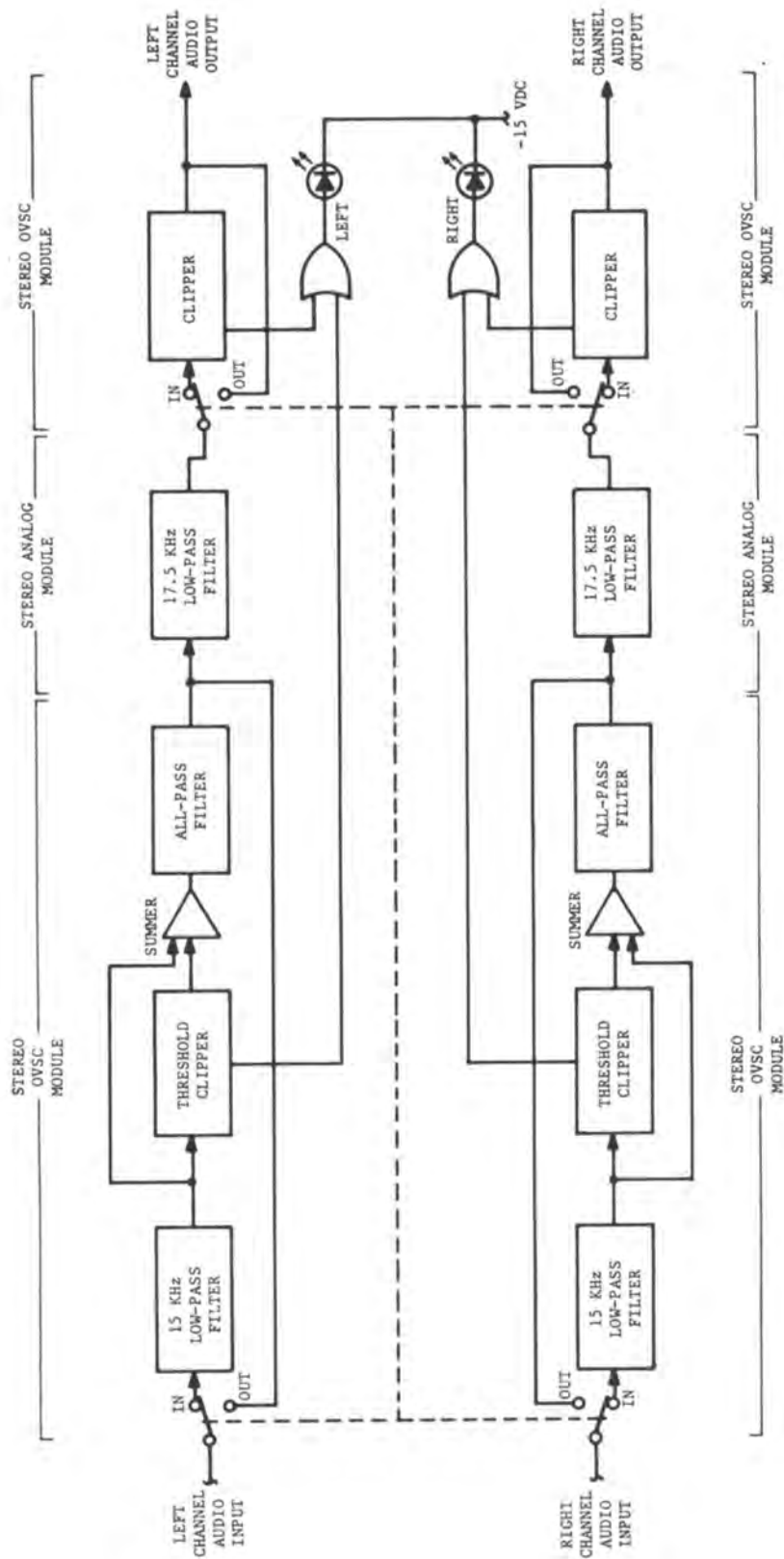

1742-53

Figure 4-1. STEREO OVSC MODULE Simplified Block Diagram

4-29. POWER. Regulated positive 20 Vdc is input to the module on pins 31 and 32 and regulated negative 20 Vdc is input to the module on pins 41 and 42. The 20 Vdc inputs are re-regulated into +15 Vdc sources by U7 and U8 as required to operate the module internal circuitry. Diodes CR29, CR30, CR31, and CR32 provide reverse current protection for each regulator and subsequent circuits. The +15V indicator (CR26) and the -15V indicator (CR25) monitor the regulated outputs and pins 24 and 26 are connected as convenient test points to assist in checking the regulator output voltage.

SECTION V

MAINTENANCE

5-1. CORRECTIVE MAINTENANCE

5-2. The MS-15 FM exciter module maintenance philosophy consists of problem isolation to a specific area or individual component and subsequent isolation and replacement of the defective component.

5-3. TROUBLESHOOTING

5-4. In event of problems, the trouble area must first be isolated to a specific area. Most troubleshooting consists of visual checks. The MODULATION meter, MULTIMETER, fuse F1, circuit breaker CB1, and the indicators on each module should be used to determine in which area the malfunction exists. All module power supplies are equipped with LEDs which indicate the module power supply status. A single dark LED would indicate a problem associated with an individual module monolithic voltage regulator. A consistent pattern of dark LEDs however, would indicate an exciter DC distribution bus fault.

5-5. Once the trouble is isolated to a specific area, refer to the theory section of this manual for circuit discussion to aid in problem resolution. Table 5-1 lists typical trouble symptoms pertaining to the individual module operation with references to fault isolation diagrams listing probable causes and corrective actions. A corrective action given for a trouble symptom is not necessarily the only answer to a problem. It only tends to lead the repairman into the area that may be causing the trouble. An extender board (HARRIS PN 992-4989-001) is provided with the exciter to assist in troubleshooting. In event parts are required, refer to Section VI, Parts List. The following information is contained in this section as an aid to maintenance:

<u>REFERENCE</u>	<u>TITLE</u>	<u>NUMBER</u>
Figure 5-1	STEREO OVSC MODULE Parts Layout	-----
Table 5-2	STEREO OVSC MODULE Parts Index	-----
Figure 5-2	STEREO OVSC MODULE Waveforms	-----
Figure 5-3	STEREO OVSC MODULE Schematic	852-8395-001

Table 5-1. STEREO OVSC MODULE Fault Isolation Index

SYMPTOM	DEFECT/REFERENCE
OVERSHOOTS	Figure 5-4
DISTORTION	Figure 5-5
NOISE	Figure 5-6
UNABLE TO SET COMPENSATION THRESHOLD	Figure 5-7
EXCESSIVE HARMONIC CONTENT	Figure 5-8
LEFT OR RIGHT INDICATORS INOPERATIVE	Figure 5-9
NO OUTPUT	Figure 5-10

Table 5-2. STEREO OVSC MODULE Parts Index

SYMBOL	LOCATION	SYMBOL	LOCATION	SYMBOL	LOCATION	SYMBOL	LOCATION	SYMBOL	LOCATION
C1	C3	C29	A3	C57	A1	CR21	A1	CR21	A1
C2	C3	C30	A3	C58	A1	CR22	A1	CR22	A1
C3	C3	C31	C1	C59	A1	CR23	B2	CR23	B2
C4	B3	C32	C3	C60	B1	CR24	B2	CR24	B2
C5	A2	C33	D2	C61	B2	CR25	A3	CR25	A3
C6	A2	C34	D2	C62	B2	CR26	A3	CR26	A3
C7	C3	C35	D2			CR27	A2	CR27	A2
C8	C3	C36	D2			CR28	A2	CR28	A2
C9	C3	C37	C1	CR1	B2	CR29	A3	CR29	A3
C10	D3	C38	B1	CR2	B2	CR30	D3	CR30	D3
C11	D3	C39	B1	CR3	A2	CR31	A3	CR31	A3
C12	D3	C40	C1	CR4	A2	CR32	D3	CR32	D3
C13	D3	C41	A2	CR5	B3				
C14	D3	C42	A1	CR6	B3				
C15	B2	C43	C1	CR7	A3	FL1	A2	FL1	A2
C16	B3	C44	C1	CR8	A3				
C17	B3	C45	C1	CR9	A3				
C18	B3	C46	D1	CR10	A3				
C19	B3	C47	D1	CR11	A3	L1	C3	L1	C3
C20	B3	C48	D1	CR12	A3	L2	D1	L2	D1
C21	B3	C49	D1	CR13	A1				
C22	B2	C50	D1	CR14	A1				
C23	B2	C51	B1	CR15	A1	R1	A2	R1	A2
C24	B2	C52	B2	CR16	A1	R2	B3	R2	B3
C25	A3	C53	B1	CR17	A1	R3	B3	R3	B3
C26	A3	C54	B1	CR18	A1	R4	B3	R4	B3
C27	A3	C55	B1	CR19	B2	R5	C3	R5	C3
C28	A3	C56	B1	CR20	B2	R6	C3	R6	C3

Table 5-2. STEREO OVSC MODULE Parts Index (Continued)

SYMBOL	LOCATION	SYMBOL	LOCATION	SYMBOL	LOCATION	SYMBOL	LOCATION	SYMBOL	LOCATION
R7	B3	R35	A3	R63	A2	R91	C2		
R8	A2	R36	A3	R64	A1	R92	C1		
R9	A3	R37	C3	R65	A1	R93	C3		
R10	A2	R38	C2	R66	A1	R94	B1		
R11	A2	R39	C2	R67	C2				
R12	A2	R40	C2	R68	C2				
R13	C2	R41	D2	R69	C2	S1	A2		
R14	C2	R42	C2	R70	C1				
R15	C3	R43	D2	R71	C1				
R16	C3	R44	C2	R72	C1	U1	C3		
R17	C3	R45	D2	R73	C1	U2	A2		
R18	C3	R46	D2	R74	C1	U3	C3		
R19	C3	R47	D1	R75	D1	U4	D3		
R20	D3	R48	C2	R76	D1	U5	B3		
R21	D3	R49	D2	R77	D1	U6	A3		
R22	D3	R50	D2	R78	D1	U7	A3		
R23	D3	R51	A3	R79	A1	U8	A3		
R24	D3	R52	A3	R80	B1	U9	C2		
R25	B3	R53	A3	R81	A1	U10	C2		
R26	B3	R54	A3	R82	B1	U11	D2		
R27	B3	R55	A2	R83	B1	U12	C1		
R28	A3	R56	B1	R84	A1	U13	A1		
R29	B3	R57	C1	R85	A1	U14	C1		
R30	A3	R58	C1	R86	A1	U15	D1		
R31	B2	R59	B1	R87	A1	U16	B1		
R32	A3	R60	B1	R88	A1	U17	A1		
R33	A3	R61	B1	R89	A1				
R34	A3	R62	A1	R90	B2				

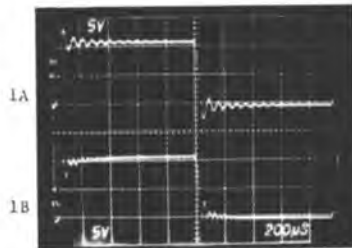

TEST REQUIREMENTS: A. 500 Hz squarewave @ 100% modulation applied to exciter.
 B. STEREO ANALOG module pre-emphasis programmed to FLAT.

- 1A Filtered audio at U12 pin 6.
- 1B Overshoot compensator output at U14 pin 6.

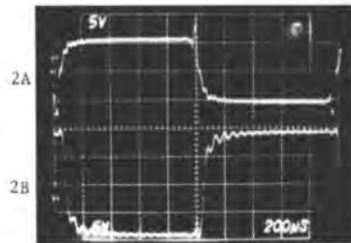

TEST REQUIREMENTS: A. 500 Hz squarewave @ 100% modulation applied to exciter.
 B. STEREO ANALOG module pre-emphasis programmed to FLAT.

- 2A All-pass filter output at U15 pin 6.
- 2B Clipper output at U16 pin 6.

1742-78

Figure 5-2. STEREO OVSC MODULE Waveforms

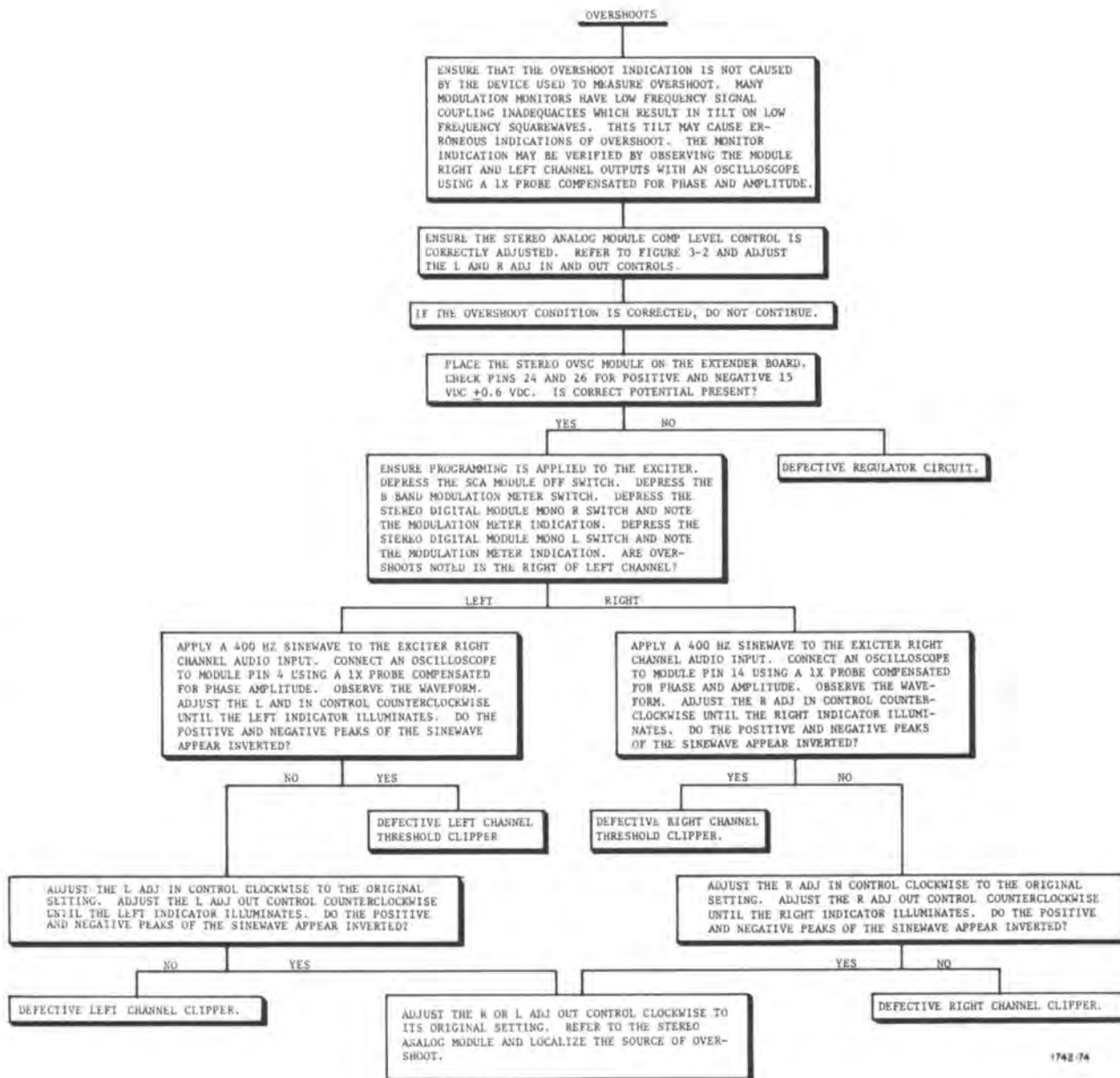
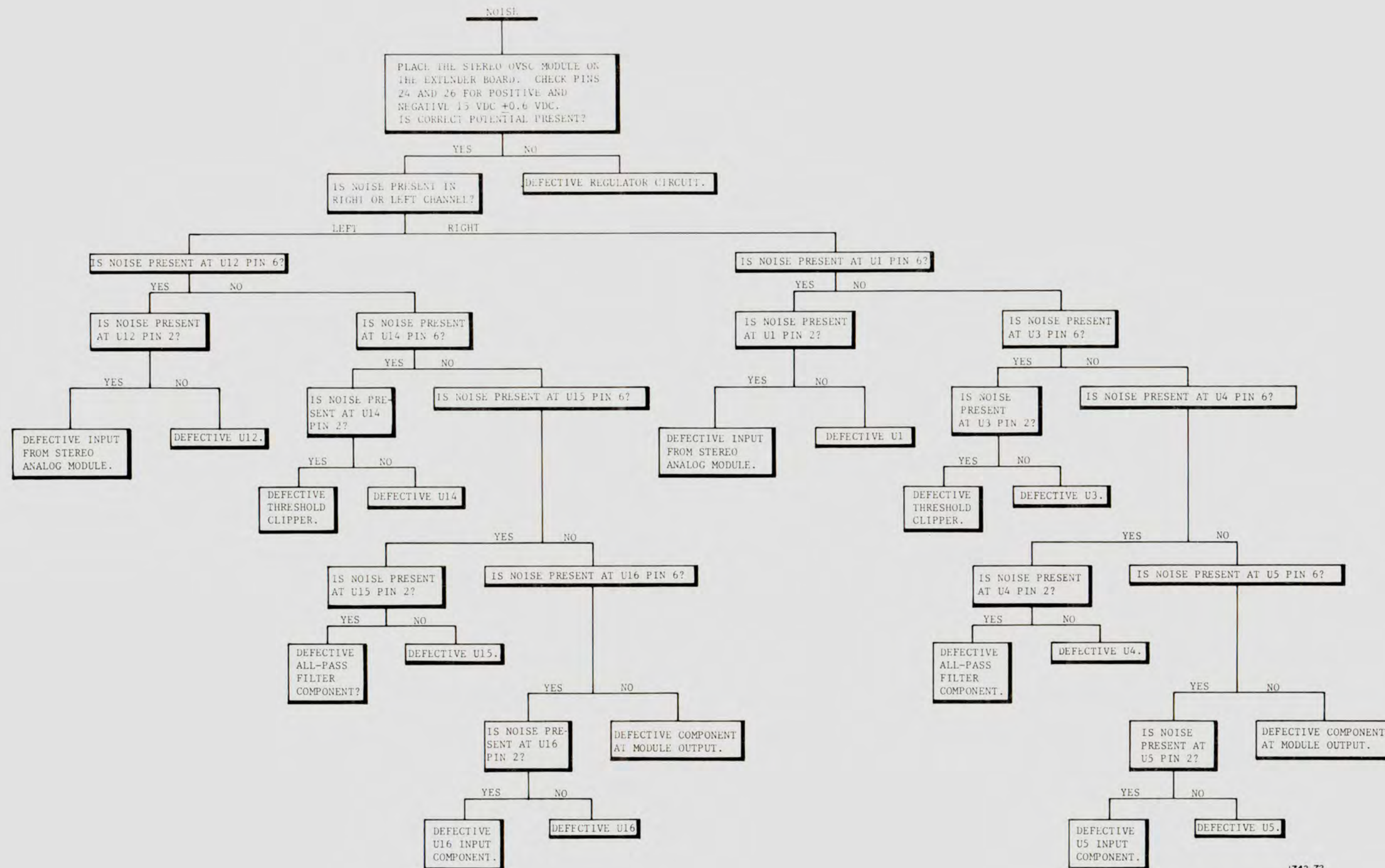

Figure 5-4. Overshoots



1742-72

FIGURE 5-6. NOISE



1742-71

Figure 5-7. Unable to Set Compensation Threshold

EXCESSIVE HARMONIC CONTENT

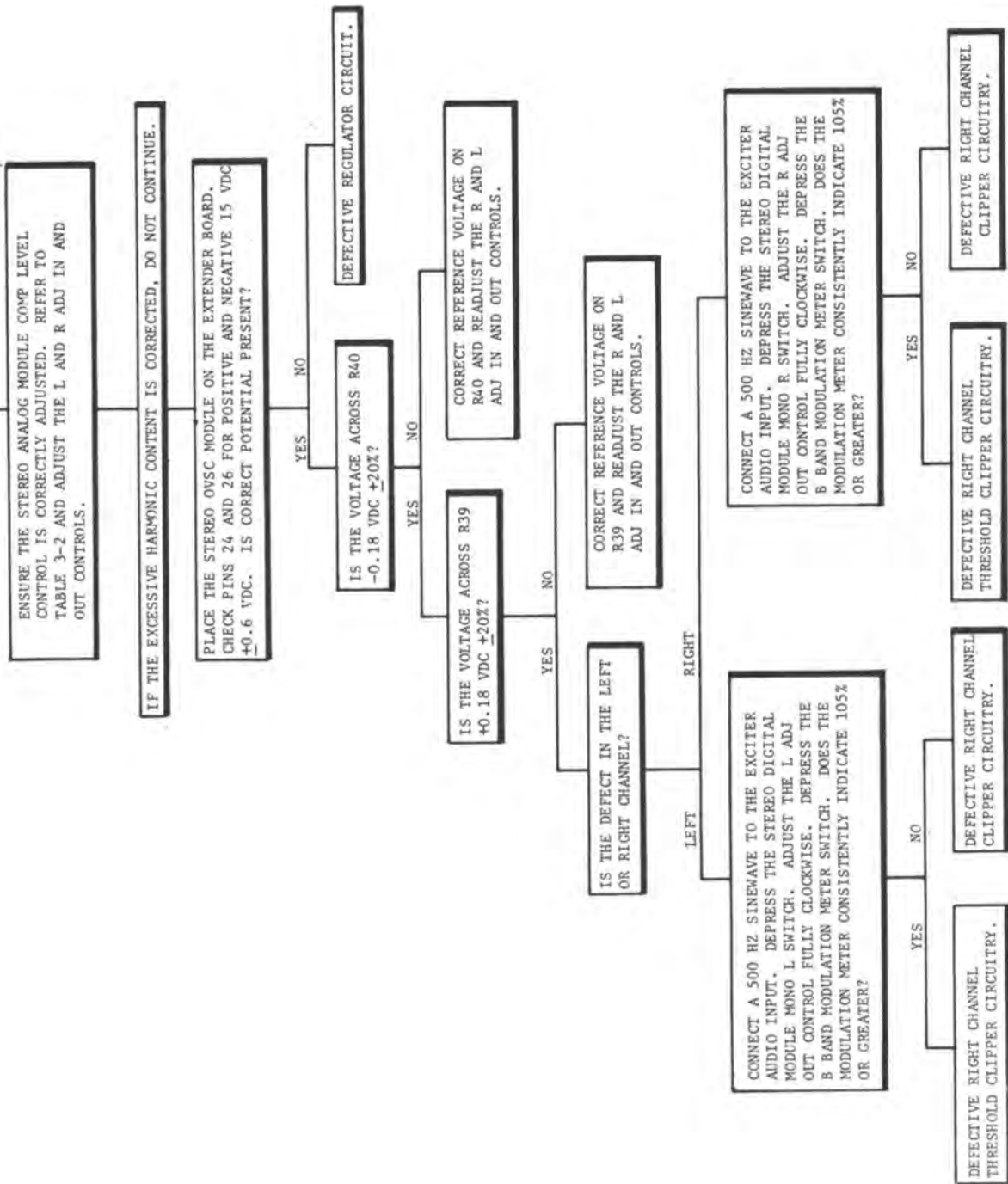

1742-63

Figure 5-8. Excessive Harmonic Content

LEFT OR RIGHT INDICATORS INOPERATIVE

PLACE THE STEREO OVSC MODULE ON THE EXTENDER BOARD. CHECK PINS 24 AND 26 FOR POSITIVE AND NEGATIVE 15 VDC +0.6 VDC. IS CORRECT POTENTIAL PRESENT?

YES

DEFECTIVE REGULATOR CIRCUIT.

NO

IS THE VOLTAGE ACROSS R39 +0.18 VDC +20%?

YES

IS THE VOLTAGE ACROSS R40 -0.18 VDC +20%?

YES

IS THE LEFT OR RIGHT INDICATOR INOPERATIVE?

LEFT

ENSURE PROGRAMMING IS APPLIED AND MONITOR MODULE PIN 28 WITH AN OSCILLOSCOPE. DOES THE LEVEL SWITCH BETWEEN -15 VDC AND GROUND?

YES

DEFECTIVE CR27.

NO

MONITOR U11 PIN 8 WITH AN OSCILLOSCOPE. DOES THE LEVEL SWITCH BETWEEN -15 VDC AND GROUND?

YES

DEFECTIVE U11.

NO

DEFECTIVE U10.

NO

CORRECT THE REFERENCE VOLTAGE ON R40. REFER TO TABLE 3-2 AND ADJUST THE R AND L IN AND OUT CONTROLS.

RIGHT

ENSURE PROGRAMMING IS APPLIED AND MONITOR MODULE PIN 30 WITH AN OSCILLOSCOPE. DOES THE LEVEL SWITCH BETWEEN -15 VDC AND GROUND?

YES

DEFECTIVE CR28.

NO

MONITOR U11 PIN 6 WITH AN OSCILLOSCOPE. DOES THE LEVEL SWITCH BETWEEN -15 VDC AND GROUND?

YES

DEFECTIVE U11.

NO

DEFECTIVE U9.

CORRECT THE REFERENCE VOLTAGE ON R39. REFER TO TABLE 3-2 AND ADJUST THE R AND L IN AND OUT CONTROLS.

Figure 5-9. Left or Right Indicators Inoperative

1742-84

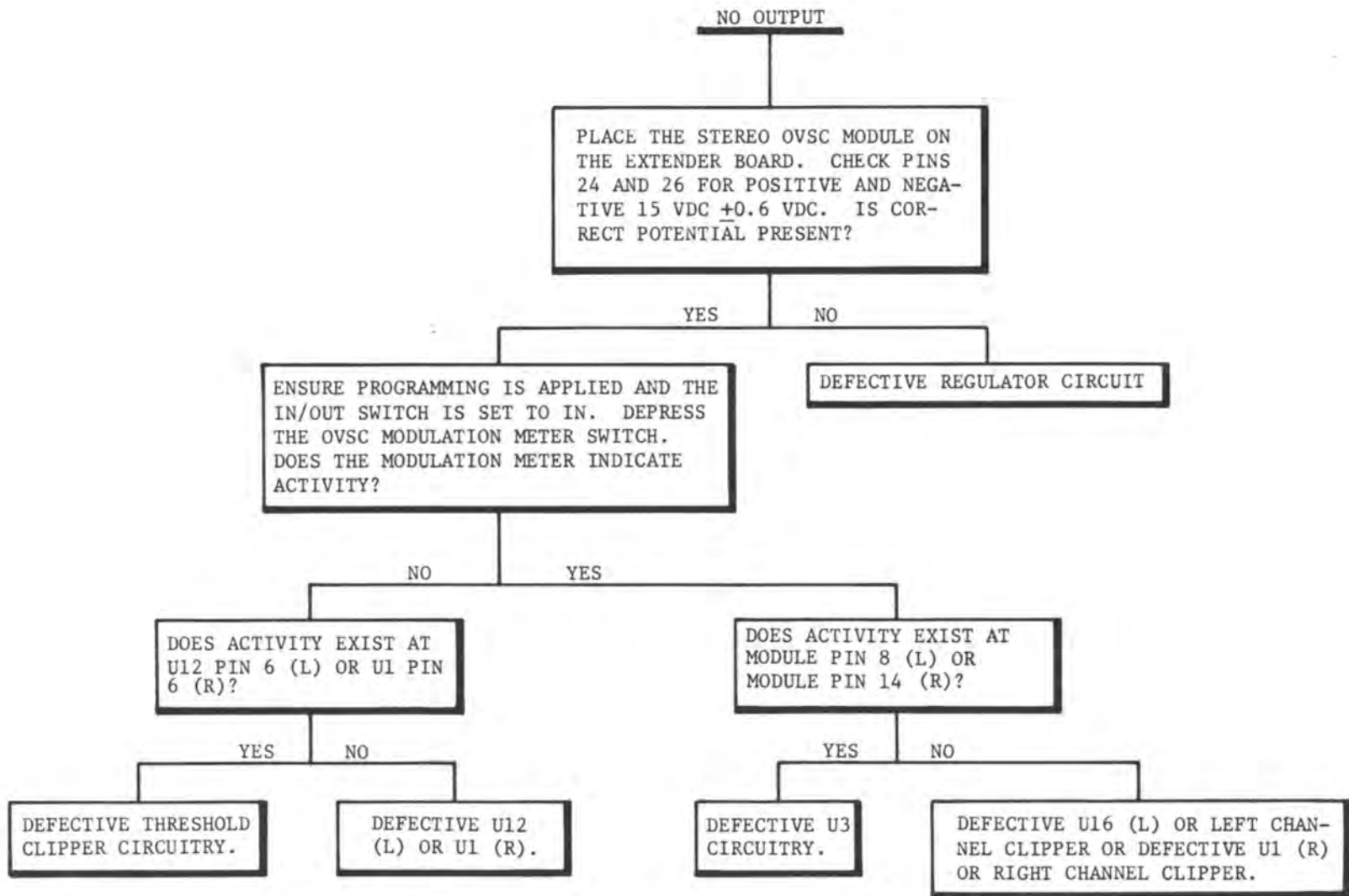

1742-70

Figure 5-10. No Output

SECTION VI

PARTS LIST

6-1. GENERAL

6-2. Refer to table 6-1 for replaceable parts which are required for proper maintenance of the MS-15 STEREO OVSC MODULE. Table entries are indexed by component reference designator.

Table 6-1. STEREO OVSC MODULE Front Panel - 994 7991 001

REF. SYMBOL	HARRIS PART NO.	DESCRIPTION	QTY.
	992 4903 001	STEREO OVSC MODULE Circuit Board (Refer to table 6-2)	1

Table 6-2. STEREO OVSC MODULE Circuit Board - 992 4903 001

REF. SYMBOL	HARRIS PART NO.	DESCRIPTION	QTY.
C1,C2	526 0049 000	Capacitor, 6.8 uF, 35V, 20%	2
C3	516 0453 000	Capacitor, 0.1 uF, 100V, 20%	1
C4	500 0803 000	Capacitor, 5 pF, 500V	1
C5	526 0045 000	Capacitor, 330 uF, 6V, 10%	1
C6	526 0057 000	Capacitor, 100 uF, 20V, 20%	1
C7,C8	526 0049 000	Capacitor, 6.8 uF, 35V, 20%	2
C9	500 0809 000	Capacitor, 22 pF, 500V, Mica	1
C10	500 0878 000	Capacitor, 1500 pF, 500V, 5%	1
C11	500 0910 000	Capacitor, 6200 pF, 300V	1
C12,C13	526 0049 000	Capacitor, 6.8 uF, 35V, 20%	2
C14	500 0809 000	Capacitor, 22 pF, 500V, Mica	1
C15,C16	526 0045 000	Capacitor, 330 uF, 6V, 10%	2
C17,C18	526 0049 000	Capacitor, 6.8 uF, 35V, 20%	2
C19	516 0453 000	Capacitor, 0.1 uF, 100V, 20%	1
C20	500 0804 000	Capacitor, 10 pF, 500V, Mica	1
C21	500 0809 000	Capacitor, 22 pF, 500V, Mica	1
C22	526 0045 000	Capacitor, 330 uF, 6V, 10%	1
C23	526 0045 000	Capacitor, 330 uF, 6V, 10%	1
C24	500 0842 000	Capacitor, 820 pF, 300V	1
C25	526 0045 000	Capacitor, 330 uF, 6V, 10%	1
C26	526 0057 000	Capacitor, 100 uF, 20V, 20%	1
C27 thru C32	526 0049 000	Capacitor, 6.8 uF, 35V, 20%	6

Table 6-2. STEREO OVSC MODULE Circuit Board - 992 4903 001 (Continued)

REF. SYMBOL	HARRIS PART NO.	DESCRIPTION	QTY.
C33	516 0375 000	Capacitor, 0.01 uF, 50V	1
C34	508 0408 000	Capacitor, 0.1 uF, 50V, 5%	1
C35	516 0375 000	Capacitor, 0.01 uF, 50V	1
C36	508 0408 000	Capacitor, 0.1 uF, 50V, 5%	1
C37,C38	526 0049 000	Capacitor, 6.8 uF, 35V, 20%	2
C39	500 0803 000	Capacitor, 5 pF, 500V, Mica	1
C40	516 0453 000	Capacitor, 0.1 uF, 100V, 20%	1
C41	526 0045 000	Capacitor, 330 uF, 6V, 10%	1
C42	526 0057 000	Capacitor, 100 uF, 20V, 20%	1
C43,C44	526 0049 000	Capacitor, 6.8 uF, 35V, 20%	2
C45	500 0809 000	Capacitor, 22 pF, 500V, Mica	1
C46	500 0878 000	Capacitor, 1500 pF, 500V, 5%	1
C47	500 0910 000	Capacitor, 6200 pF, 300V	1
C48,C49	526 0049 000	Capacitor, 6.8 uF, 35V, 20%	2
C50	500 0809 000	Capacitor, 22 pF, 500V, Mica	1
C51,C52	526 0045 000	Capacitor, 330 uF, 6V, 10%	2
C53,C54	526 0049 000	Capacitor 6.8 uF, 35V, 20%	2
C55	516 0453 000	Capacitor, 0.1 uF, 100V, 20%	1
C56	500 0804 000	Capacitor, 10 pF, 500V, Mica	1
C57	500 0809 000	Capacitor, 22 pF, 500V, Mica	1
C58	526 0045 000	Capacitor, 330 uF, 6V, 10%	1
C59	526 0057 000	Capacitor, 100 uF, 20V, 20%	1

Table 6-2. STEREO OVSC MODULE Circuit Board - 992 4903 001 (Continued)

REF. SYMBOL	HARRIS PART NO.	DESCRIPTION	QTY.
C60,C61	526 0045 000	Capacitor, 330 uF, 6V, 10%	2
C62	500 0842 000	Capacitor, 820 pF, 300V, Mica	1
CR1,CR2,CR3	384 0205 000	Diode, Silicon, 1N914	3
CR4 thru CR9	384 0321 000	Diode, Hot Carrier	6
CR10,CR11,CR12	384 0205 000	Diode, Silicon, 1N914	3
CR13,CR14,CR15	384 0321 000	Diode, Hot Carrier	3
CR16 thru CR21	384 0205 000	Diode, Silicon 1N914	6
CR22,CR23,CR24	384 0321 000	Diode, Hot Carrier	3
CR25,CR26	384 0661 000	LED, Green	2
CR27,CR28	384 0662 000	LED, Red	2
CR29 thru CR32	384 0284 000	Diode, 10D4/1N2070	4
FL1	484 0265 000	Filter, Dual Low-Pass	1
L1,L2	492 0645 000	Inductor, 100 mH, 2%	2
R1	548 0678 000	Resistor, 4750 ohms, 1/4W, 1%	1
R2	548 1361 000	Resistor, 10k ohms, 1/4W, 1%	1
R3	540 1184 000	Resistor, 1/2W, 15k ohms, 5%	1
R4	548 1424 000	Resistor, 95.3k ohms, 1/4W, 1%	1
R5,R6	540 1228 000	Resistor, 12 ohms, 1/2W, 5%	2
R7	548 1431 000	Resistor, 78.7k ohms, 1/4W	1
R8	540 1182 000	Resistor, 2200 ohms, 1/2W, 5%	1
R9	540 1145 000	Resistor, 6800 ohms, 1/2W, 5%	1
R10	550 0914 000	Potentiometer, 10k ohms	1

Table 6-2. STEREO OVSC MODULE Circuit Board - 992 4903 001 (Continued)

REF. SYMBOL	HARRIS PART NO.	DESCRIPTION	QTY.
R11	540 1189 000	Resistor, 9100 ohms, 1/2W, 5%	1
R12	540 1182 000	Resistor, 2200 ohms, 1/2W, 5%	1
R13	540 1111 000	Resistor, 10k ohms, 1/2W, 5%	1
R14	540 1129 000	Resistor, 1500 ohms, 1/2W, 5%	1
R15	548 1186 000	Resistor, 27.4k ohms, 1/4W, 1%	1
R16	548 1361 000	Resistor, 10k ohms, 1/4W, 1%	1
R17	548 1431 000	Resistor, 78.7k ohms, 1/4W	1
R18 thru R21	540 1228 000	Resistor, 12 ohms, 1/2W, 5%	4
R22	540 1105 000	Resistor, 5100 ohms, 1/2W, 5%	1
R23,R24	548 1361 000	Resistor, 10k ohms, 1/4W, 1%	2
R25,R26	540 1228 000	Resistor, 12 ohms, 1/2W, 5%	2
R27	548 0279 000	Resistor, 2000 ohms, 1/4W, 1%	1
R28	548 1358 000	Resistor, 6650 ohms, 1/4W, 1%	1
R29	540 1145 000	Resistor, 6800 ohms, 1/2W, 5%	1
R30	540 1105 000	Resistor, 5100 ohms, 1/2W, 5%	1
R31	548 1430 000	Resistor, 23.2k ohms, 1/4W, 1%	1
R32	540 1147 000	Resistor, 27k ohms, 1/2W, 5%	1
R33	550 0914 000	Potentiometer, 10k ohms	1
R34	540 1189 000	Resistor, 9100 ohms, 1/2W, 5%	1
R35,R36	540 1182 000	Resistor, 2200 ohms, 1/2W, 5%	2
R37,R38	540 1160 000	Resistor, 22k ohms, 1/2W, 5%	2
R39,R40	540 1188 000	Resistor, 270 ohms, 1/2W, 5%	2

Table 6-2. STEREO OVSC MODULE Circuit Board - 992 4903 001 (Continued)

REF. SYMBOL	HARRIS PART NO.	DESCRIPTION	QTY.
R41,R42	540 1122 000	Resistor, 47k ohms, 1/2W, 5%	2
R43 thru R46	540 1159 000	Resistor, 100k ohms, 1/2W, 5%	4
R47,R48	540 1187 000	Resistor, 1300 ohms, 1/2W, 5%	2
R49,R50	540 1159 000	Resistor, 100k ohms, 1/2W, 5%	2
R51,R52	540 1323 000	Resistor, 3.3 ohms, 1/2W, 5%	2
R53,R54	540 1187 000	Resistor, 1300 ohms, 1/2W, 5%	2
R55	548 0678 000	Resistor, 4750 ohms, 1/2W, 1%	1
R56	548 1424 000	Resistor, 95.3k ohms, 1/4W, 1%	1
R57,R58	540 1228 000	Resistor, 12 ohms, 1/2W, 5%	2
R59	540 1184 000	Resistor, 15k ohms, 1/2W, 5%	1
R60	548 1361 000	Resistor, 10k ohms, 1/4W, 1%	1
R61	548 1431 000	Resistor, 78.7k ohms, 1/4W, 1%	1
R62	540 1182 000	Resistor, 2200 ohms, 1/2W, 5%	1
R63	540 1145 000	Resistor, 6800 ohms, 1/2W, 5%	1
R64	550 0914 000	Potentiometer, 10k ohms	1
R65	540 1189 000	Resistor, 9100 ohms, 1/2W, 5%	1
R66	540 1182 000	Resistor, 2200 ohms, 1/2W, 5%	1
R67	540 1129 000	Resistor, 1500 ohms, 1/2W, 5%	1
R68	540 1111 000	Resistor, 10k ohms, 1/2W, 5%	1
R69	548 1186 000	Resistor, 27.4k ohms, 1/4W, 1%	1
R70	548 1361 000	Resistor, 10k ohms, 1/4W, 1%	1
R71	548 1431 000	Resistor, 78.7k ohms, 1/4W, 1%	1

Table 6-2. STEREO OVSC MODULE Circuit Board - 992 4903 001 (Continued)

REF. SYMBOL	HARRIS PART NO.	DESCRIPTION	QTY.
R72,R73	540 1228 000	Resistor, 12 ohms, 1/2W, 5%	2
R74	540 1105 000	Resistor, 5100 ohms, 1/2W, 5%	1
R75,R76	548 1361 000	Resistor, 10k ohms, 1/4W, 1%	2
R77,R78	540 1228 000	Resistor, 12 ohms, 1/2W, 5%	2
R79	540 1145 000	Resistor, 6800 ohms, 1/2W, 5%	1
R80	548 0279 000	Resistor, 2000 ohms, 1/4W, 1%	1
R81	548 1358 000	Resistor, 6650 ohms, 1/4W, 1%	1
R82,R83	540 1228 000	Resistor, 12 ohms, 1/2W, 5%	2
R84	540 1105 000	Resistor, 5100 ohms, 1/2W, 5%	1
R85	540 1182 000	Resistor, 2200 ohms, 1/2W, 5%	1
R86	540 1147 000	Resistor, 27k ohms, 1/2W, 5%	1
R87	550 0914 000	Potentiometer, 10k ohms	1
R88	540 1189 000	Resistor, 9100 ohms, 1/2W, 5%	1
R89	540 1182 000	Resistor, 2200 ohms, 1/2W, 5%	1
R90	548 1430 000	Resistor, 23.2k ohms, 1/4W, 1%	1
R91,R92	540 1144 000	Resistor, 200k ohms, 1/2W, 5%	2
R93,R94	550 0930 000	Potentiometer, 200k ohms, 1/2W	2
S1	600 0581 000	Switch, Rotary, 8PDT	1
U1	382 0472 000	Integrated Circuit	1
U2	382 0520 000	Integrated Circuit, Regulator	1
U3,U4,U5	382 0472 000	Integrated Circuit	3
U6	382 0520 000	Integrated Circuit, Regulator	1

Table 6-2. STEREO OVSC MODULE Circuit Board - 992 4903 001 (Continued)

REF. SYMBOL	HARRIS PART NO.	DESCRIPTION	QTY.
U7	382 0359 000	Integrated Circuit, MC7815CP	1
U8	382 0360 000	Integrated Circuit, MC7915CP	1
U9,U10	382 0521 000	Integrated Circuit, LM339N	2
U11	382 0381 000	Integrated Circuit, NE556A	1
U12	382 0472 000	Integrated Circuit, LM318N	1
U13	382 0520 000	Integrated Circuit, Regulator	1
U14,U15,U16	382 0472 000	Integrated Circuit, LM318N	3
U17	382 0520 000	Integrated Circuit, Regulator	1
XU1 thru XU5	404 0673 000	Socket, IC, 8 Contact	4
XU9,XU10,XU11	404 0674 000	Socket, IC, 14 Contact	3
XU12 thru XU16	404 0673 000	Socket, IC, 8 Contact	4
	939 3564 001	Printed Circuit Board	1

TECHNICAL MANUAL

AFC/PLL MODULE

992 4985 001



HARRIS CORPORATION

Broadcast Products Division

T.M. No. 888-1742-007

Printed: October 1977
Revision A: February 1978
Revision B: August 1978
Revision C: April 1980
Revision E: March 1981
Revision F: June 1981

MANUAL REVISION HISTORY

MCN OR REV. NO	MCN OR REV. DATE	ECN NO.	DESCRIPTION OF CHANGE
F-1	02/03/82	26679	<p>Revision F: June 1981</p> <p>On page 23/24, figure 5-3, schematic 852 8394 001, AFC/PLL Module Schematic. Change to Revision D.</p> <p>Change figure 4-3 to 1742-5A.</p>
F-2	06/08/82	26753	<p>Page 35, Table 6-2. AFC/PLL Module Circuit Board - 992 4986 001. Change C7 and C32, 508 0336 000, Capacitor, 0.5 uF, 100V, 10% TO 508 0345 000, Capacitor, .47 uF, 200V, 10%.</p> <p>Page 23/24, Figure 5-3. AFC/PLL Module Schematic 852 8394 001, change to Rev. E according to ECN 26753.</p>

WARNING

THE CURRENTS AND VOLTAGES IN THIS EQUIPMENT ARE DANGEROUS. PERSONNEL MUST AT ALL TIMES OBSERVE SAFETY REGULATIONS.

This manual is intended as a general guide for trained and qualified personnel who are aware of the dangers inherent in handling potentially hazardous electrical/electronic circuits. It is not intended to contain a complete statement of all safety precautions which should be observed by personnel in using this or other electronic equipment.

The installation, operation, maintenance and service of this equipment involves risks both to personnel and equipment, and must be performed only by qualified personnel exercising due care. HARRIS CORPORATION shall not be responsible for injury or damage resulting from improper procedures or from the use of improperly trained or inexperienced personnel performing such tasks.

During installation and operation of this equipment, local building codes and fire protection standards must be observed. The following National Fire Protection Association (NFPA) standards are recommended as references:

- Automatic Fire Detectors, No. 72E
- Installation, Maintenance, and Use of Portable Fire Extinguishers, No. 10
- Halogenated Fire Extinguishing Agent Systems, No. 12A

WARNING

ALWAYS DISCONNECT POWER BEFORE OPENING COVERS, DOORS, ENCLOSURES, GATES, PANELS OR SHIELDS. ALWAYS USE GROUNDING STICKS AND SHORT OUT HIGH VOLTAGE POINTS BEFORE SERVICING. NEVER MAKE INTERNAL ADJUSTMENTS, PERFORM MAINTENANCE OR SERVICE WHEN ALONE OR WHEN FATIGUED.

Do not remove, short-circuit or tamper with interlock switches on access covers, doors, enclosures, gates, panels or shields. Keep away from live circuits, know your equipment and don't take chances.

WARNING

IN CASE OF EMERGENCY ENSURE THAT POWER HAS BEEN DISCONNECTED.

Treatment of Electrical Shock

1. If victim is not responsive follow the A-B-Cs of basic life support.

PLACE VICTIM FLAT ON HIS BACK ON A HARD SURFACE

A AIRWAY

IF UNCONSCIOUS,
OPEN AIRWAY



LIFT UP NECK
PUSH FOREHEAD BACK
CLEAR OUT MOUTH IF NECESSARY
OBSERVE FOR BREATHING

B BREATHING

IF NOT BREATHING,
BEGIN ARTIFICIAL
BREATHING



TILT HEAD
PINCH NOSTRILS
MAKE AIRTIGHT SEAL

4 QUICK FULL BREATHS

REMEMBER MOUTH TO MOUTH RESUSCITATION
MUST BE COMMENCED AS SOON AS POSSIBLE

CHECK CAROTID PULSE



IF PULSE ABSENT,
BEGIN ARTIFICIAL
CIRCULATION

C CIRCULATION

DEPRESS STERNUM 1 1/2" TO 2"

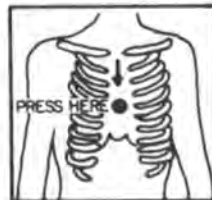

APPROX. { ONE RESCUER
80 SEC. { 15 COMPRESSIONS
2 QUICK BREATHS

APPROX. { TWO RESCUERS
60 SEC. { 5 COMPRESSIONS
1 BREATH



NOTE: DO NOT INTERRUPT RHYTHM OF COMPRESSIONS
WHEN SECOND PERSON IS GIVING BREATH

Call for medical assistance as soon as possible.

2. If victim is responsive.
 - a. keep them warm
 - b. keep them as quiet as possible
 - c. loosen their clothing
(a reclining position is recommended)

FIRST-AID

Personnel engaged in the installation, operation, maintenance or servicing of this equipment are urged to become familiar with first-aid theory and practices. The following information is not intended to be complete first-aid procedures, it is brief and is only to be used as a reference. It is the duty of all personnel using the equipment to be prepared to give adequate Emergency First Aid and thereby prevent avoidable loss of life.

Treatment of Electrical Burns

1. Extensive burned and broken skin
 - a. Cover area with clean sheet or cloth. (Cleanest available cloth article.)
 - b. Do not break blisters, remove tissue, remove adhered particles of clothing, or apply any salve or ointment.
 - c. Treat victim for shock as required.
 - d. Arrange transportation to a hospital as quickly as possible.
 - e. If arms or legs are affected keep them elevated.

NOTE

If medical help will not be available within an hour and the victim is conscious and not vomiting, give him a weak solution of salt and soda: 1 level teaspoonful of salt and 1/2 level teaspoonful of baking soda to each quart of water (neither hot or cold). Allow victim to sip slowly about 4 ounces (a half of glass) over a period of 15 minutes. Discontinue fluid if vomiting occurs. (Do not give alcohol.)

2. Less severe burns - (1st & 2nd degree)
 - a. Apply cool (not ice cold) compresses using the cleanest available cloth article.
 - b. Do not break blisters, remove tissue, remove adhered particles of clothing, or apply salve or ointment.
 - c. Apply clean dry dressing if necessary.
 - d. Treat victim for shock as required.
 - e. Arrange transportation to a hospital as quickly as possible.
 - f. If arms or legs are affected keep them elevated.

REFERENCE: ILLINOIS HEART ASSOCIATION

AMERICAN RED CROSS STANDARD FIRST AID AND PERSONAL SAFETY MANUAL
(SECOND EDITION)

TABLE OF CONTENTS

<u>Paragraph</u>		<u>Page</u>
SECTION I. GENERAL DESCRIPTION		
1-1.	Equipment Purpose	1
1-3.	Technical Characteristics	1
SECTION II. INSTALLATION		
2-1.	General	1
SECTION III. CONTROLS AND INDICATORS		
3-1.	General	1
SECTION IV. PRINCIPLES OF OPERATION		
4-1.	Circuit Description	1
4-3.	Phase Locked Loop	6
4-6.	Module General Description	6
4-7.	Voltage Controlled Oscillator	6
4-8.	Dividers	6
4-9.	Error Signal	8
4-10.	Lock Detector	8
4-11.	Module Detailed Description	8
4-12.	Temperature Compensated Crystal Oscillator (TCXO)	8
4-13.	Divide by 3200 Counter	8
4-14.	RF Frequency Divider	8
4-15.	Programmable Divider	11
4-16.	Programmable Divider Operation	11
4-17.	Missing Pulse Detectors	11
4-18.	Lock Detector	11
4-19.	Lock Flip Flop	11
4-21.	Level Detector/Delay	12
4-22.	Phase Comparator	12
4-23.	Bistable Loop	12
4-24.	Power	15
SECTION V. MAINTENANCE		
5-1.	Corrective Maintenance	15
5-3.	Troubleshooting	15
SECTION VI. PARTS LIST		
6-1.	General	33

LIST OF TABLES

<u>Table</u>	<u>Page</u>
1-1. Technical Characteristics	2
3-1. AFC/PLL MODULE Controls and Indicators	4
3-2. Control Adjustments	5
4-1. Frequency Program Chart	13
5-1. AFC/PLL MODULE Fault Isolation Index	17
5-2. AFC/PLL MODULE Parts Index	19
6-1. AFC/PLL MODULE Front Panel	34
6-2. AFC/PLL MODULE Circuit Board	35

LIST OF ILLUSTRATIONS

<u>Figure</u>	<u>Page</u>
3-1. AFC/PLL MODULE	3
4-1. Phase Locked Loop	6
4-2. AFC/PLL MODULE Simplified Block Diagram	7
4-3. AFC/PLL MODULE Detailed Block Diagram	9
4-4. Detector Waveforms	12
5-1. AFC/PLL MODULE Parts Layout	18
5-2. AFC/PLL MODULE Waveforms	21
5-3. AFC/PLL MODULE Schematic	23
5-4. Loop Will Not Lock (Lock Indicator Out)	25
5-5. Loop Locks on Incorrect Frequency (Lock Indicator Illuminated) ...	27
5-6. Noise	29
5-7. 3125 Hz Whine	30
5-8. Slow Wavering of Frequency (Lock Indicator Illuminated)	31
5-9. Loop Locks Then Quickly Unlocks	32

SECTION I

GENERAL DESCRIPTION

1-1. EQUIPMENT PURPOSE

1-2. The AFC/PLL MODULE controls the center frequency of any 50 kHz spaced channel within the 87.5 MHz to 108 MHz commercial FM broadcast band. A programmable divider and a temperature compensated crystal oscillator (TCXO) are interfaced with the MOD OSC module to maintain accurate frequency control through use of a phase locked loop. A test point is provided for WWV comparisons of the internal reference frequency for calibration adjustments.

1-3. TECHNICAL CHARACTERISTICS

1-4. Table 1-1 lists operating characteristics and parameters of the MS-15 AFC/PLL MODULE.

SECTION II

INSTALLATION

2-1. GENERAL

2-2. Refer to 888 1742 001, MS-15 FM Exciter, Section II, Installation.

SECTION III

CONTROLS AND INDICATORS

3-1. GENERAL

3-2. Figure 3-1 shows the location of each control or indicator associated with the MS-15 AFC/PLL and table 3-1 lists the controls and indicators with a description of each item listed. Control setup adjustments are listed in table 3-2.

SECTION IV

PRINCIPLES OF OPERATION

4-1. CIRCUIT DESCRIPTION

4-2. The primary purpose of the AFC/PLL MODULE is to control the MS-15 rf carrier center frequency. The AFC/PLL module interfaces with the MOD OSC module to form a phase locked loop to accomplish accurate frequency control.

Table 1-1. Technical Characteristics

FUNCTION	CHARACTERISTIC
<u>INPUTS</u>	
POWER:	+20 Vdc @ 0.028 amperes.
	+15 Vdc @ 0.022 amperes.
	-15 Vdc @ 0.018 amperes.
	+5 Vdc @ 0.460 amperes.
SIGNAL:	
RF DRIVE	2.0 milliwatts on-frequency rf.
<u>OUTPUTS</u>	
CONTROL:	
RF INHIBIT	Ground for inhibit. Open for operate.
RELAY K1 CONTROL	Ground for frequency locked condition; +20 Vdc for frequency unlocked condition.
AFC CONTROL	+3.0 Vdc to +12.0 Vdc, dependent upon exciter operating frequency.
METER VOLTAGE	+3.0 Vdc to +12.0 Vdc, dependent upon exciter operating frequency.

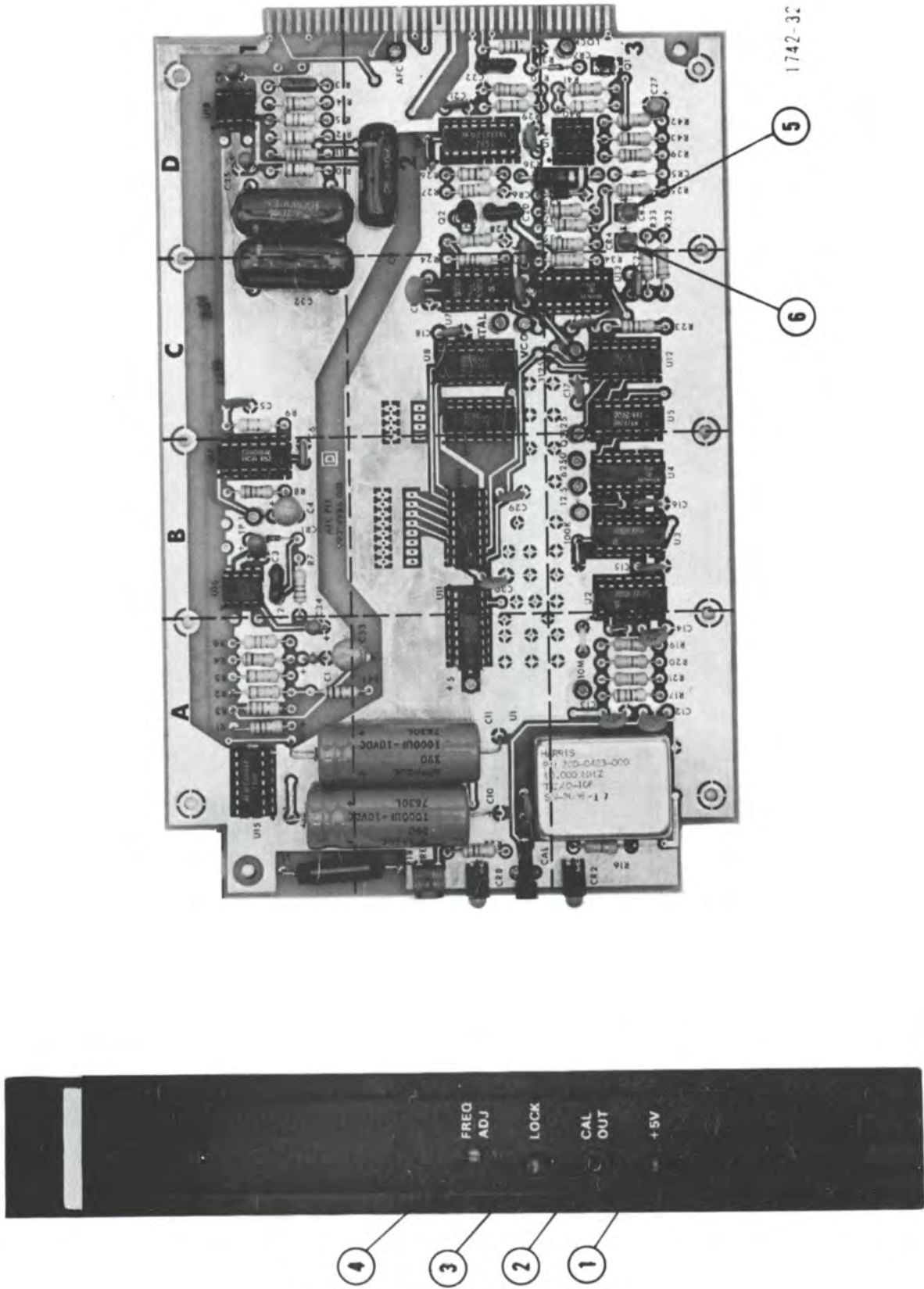

1742-3C

Figure 3-1. AFC/PLL MODULE

Table 3-1. AFC/PLL MODULE Controls and Indicators

REF.	CONTROL/INDICATOR	FUNCTION
1	+5V Indicator (CR2)	Illuminates to indicate the +5 volt input to AFC/PLL MODULE is present.
2	CAL OUT Test Point	Provides frequency components at 2.5 MHz, 5.0 MHz, 10.0 MHz, 20.0 MHz, and 25.0 MHz for direct frequency comparisons between the internal frequency standard and a broadcast frequency standard such as WWV using a communications receiver.
3	LOCK Indicator (CR8)	Illuminates to indicate the exciter is operating within tolerance of the assigned frequency.
4	FREQ ADJ Control (R18)	Adjusts the FM carrier frequency.
5	MOD OSC Indicator (CR3)	Illuminates to indicate the MOD OSC module rf divider chain is operational.
6	CRYSTAL REFERENCE Indicator (CR4)	Illuminates to indicate the MOD OSC module crystal oscillator and reference divider chain is operational.

Table 3-2. Control Adjustments

CONTROL	ADJUSTMENT
<p>FREQ ADJ Control (R18)</p>	<ol style="list-style-type: none"> 1. Adjust a communication receiver to receive a broadcast frequency standard such as WWV at one of the following frequencies: <ul style="list-style-type: none"> 2.5 MHz } WWV 5.0 MHz } } 10.0 MHz } INTERNATIONAL 15.0 MHz } 20.0 MHz } 25.0 MHz } 2. Connect a short piece of wire to be used as an antenna to the AFC/PLL MODULE CAL OUT test point. Couple the wire to the receiver antenna as required to obtain a signal. 3. Adjust R18 to obtain a zero beat. 4. Disconnect the wire from the CAL OUT test point.

4-3. PHASE LOCKED LOOP

4-4. A phase locked loop (see figure 4-1) is an automatic frequency control system that develops an error signal which is used as a control voltage to eliminate the system frequency error. The VCO operates as a frequency source whose phase is compared to the phase of a reference oscillator of the same frequency. The phase detector output is applied to a loop filter which determines lockup and modulation characteristics. If used for FM, the loop filter must average out the frequency or phase modulation that is present at the phase detector.

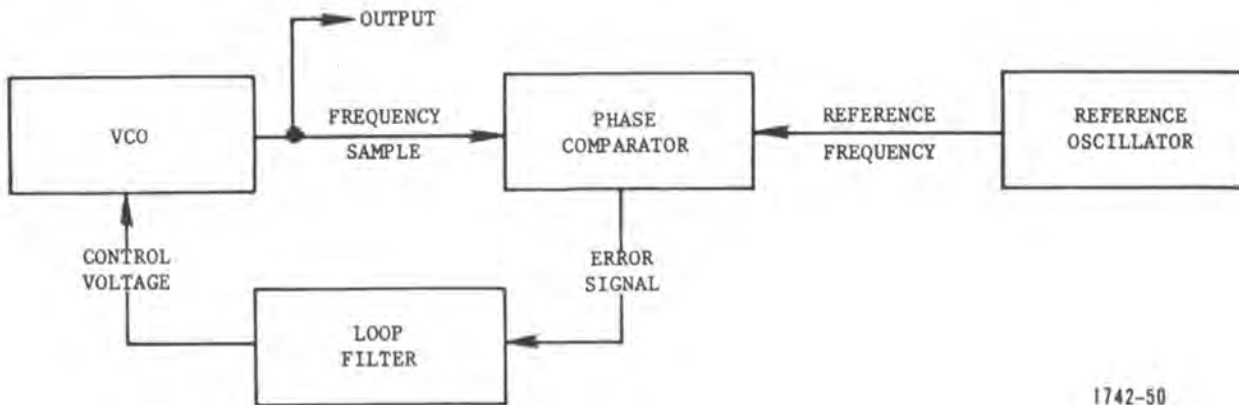

1742-50

Figure 4-1. Phase Locked Loop

4-5. The directly controlled parameter of a phase locked loop is not frequency, but phase. As frequency is the rate of change of phase, by controlling phase with a finite constant error, frequency is controlled with no error with respect to the reference frequency. Therefore the phase locked loop indirectly controls frequency by accurately controlling phase.

4-6. MODULE GENERAL DESCRIPTION

4-7. VOLTAGE CONTROLLED OSCILLATOR. When power is applied, the MOD OSC module rf amplifiers drive the RF AMP module and provide an rf frequency sample to the AFC/PLL MODULE frequency dividers (see figure 4-2). As the phase locked loop is unlocked at this time, any rf transmission would be off frequency. Therefore, until phase lock is established a ground applied to the RF AMP module by the AFC/PLL MODULE inhibits rf output.

4-8. DIVIDERS. The rf frequency sample is divided to a frequency of 3125 Hz and applied to the lock detector and phase comparator. Frequency changes are accomplished through use of a programmable divider. The reference frequency is established by a highly stable temperature compensated crystal oscillator (TCXO). The CAL OUT test point and the FREQ ADJ control allow calibration of the reference standard. The reference frequency is divided down into two outputs of 3125 Hz, one signal lagging 90 degrees in phase. The 3125 Hz signal is applied to the phase comparator and the lock detector. The 3125 Hz quadrature signal is applied to the lock detector.

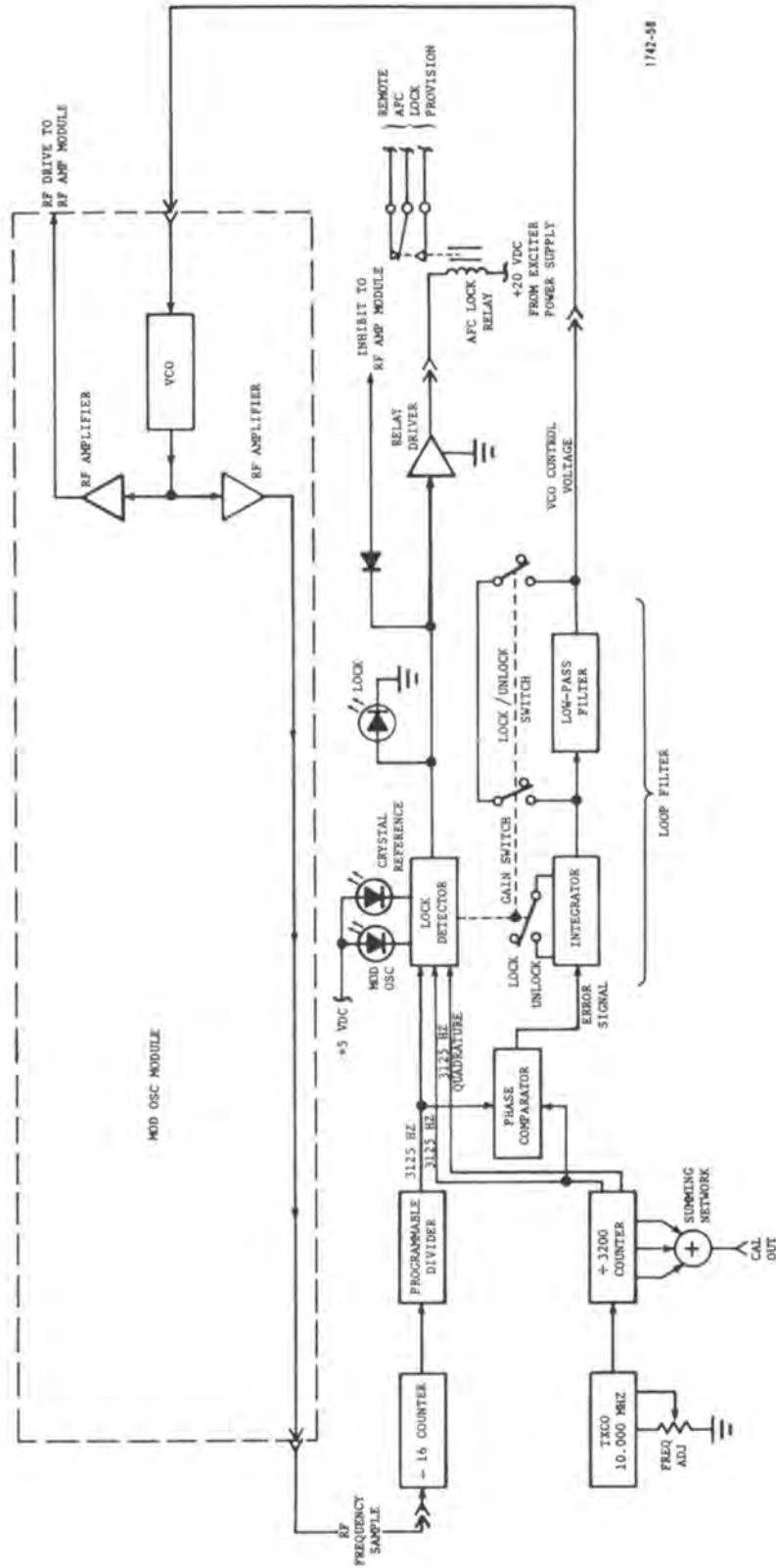

1742-58

Figure 4-2. AFC/PLL MODULE Simplified Block Diagram

4-9. ERROR SIGNAL. The two 3125 Hz signals applied to the phase comparator provide an error signal to the loop filter consisting of the integrator and low-pass filter. When the frequency is unlocked, a gain switch increases the rate of correction and bypasses the low-pass filter for rapid loop response. When frequency lock is detected, the gain switch opens to slow the rate of correction and enable the low-pass filter. The module output is applied to the MOD OSC module to correct the VCO center frequency.

4-10. LOCK DETECTOR. The three 3125 Hz signals applied to the lock detector are used to determine if the frequency divider and the reference divider are operational and if the loop is in a frequency locked condition. Visual indications of the divider status and frequency lock are provided by light emitting diodes. When the loop is unlocked, the integrator gain is increased and a ground applied to the lock detector output opens the AFC lock relay and inhibits exciter rf output. When the loop is locked, the integrator gain is reduced, the AFC lock relay energizes and exciter rf output is enabled.

4-11. MODULE DETAILED DESCRIPTION

4-12. TEMPERATURE COMPENSATED CRYSTAL OSCILLATOR (TCXO). The internal reference frequency is produced by a 10.0 MHz temperature compensated crystal oscillator (TCXO) (see figure 4-3). The TCXO comprises a sealed modular oscillator with an internal thermistor and varactor diode network matched to the crystal to compensate for a wide range of ambient temperatures. The unit is highly stable with an aging specification of ± 2 Hz per year/per MHz (± 2 PPM). The frequency of the TCXO may be adjusted with the FREQ ADJ control (R18) over approximately ± 1.7 kHz. Due to the limited effect of the FREQ ADJ control, it is not likely that accidental adjustment of the frequency control would put the transmitter off frequency beyond FCC limits. The output of the TCXO drives a divide by 3200 counter consisting of U2, U3, U4, and U5.

4-13. DIVIDE BY 3200 COUNTER. The first divide-by-two stages (U2A and U3A) provide outputs at 5.0 MHz and 2.5 MHz. The signals are summed with the output of the TCXO through resistors R19, R20, and R21 to produce a signal with frequency components at 2.5 MHz, 5.0 MHz, 10.0 MHz, 15.0 MHz, 20.0 MHz, and 25 MHz at the CAL OUT test point. This enables comparisons of the phase locked loop reference frequency with any international broadcast frequency standard such as WWV by attaching a short antenna to the test point, coupling an rf sample into a general coverage receiver, and adjusting FREQ CAL for zero beat. The 2.5 MHz signal is divided down to 3125 Hz by a divide by 800 counter consisting of U2B, U3B, U4B, U5A, U4A, and U5B. Test points are provided along the divider chain to assist in troubleshooting. Two 3125 Hz signals are output by the reference divider chain. One signal obtained from U4A is used as the reference for the phase detector. The second signal which is obtained from U5B lags the first signal by 90 degrees and is used by the lock detector to determine phase lock.

4-14. RF FREQUENCY DIVIDER. On frequency rf from the MOD OSC module is input to the AFC/PLL MODULE at a level of two milliwatts. A divide by 16 counter divides the rf input down to the six MHz range to operate the

2/10/10

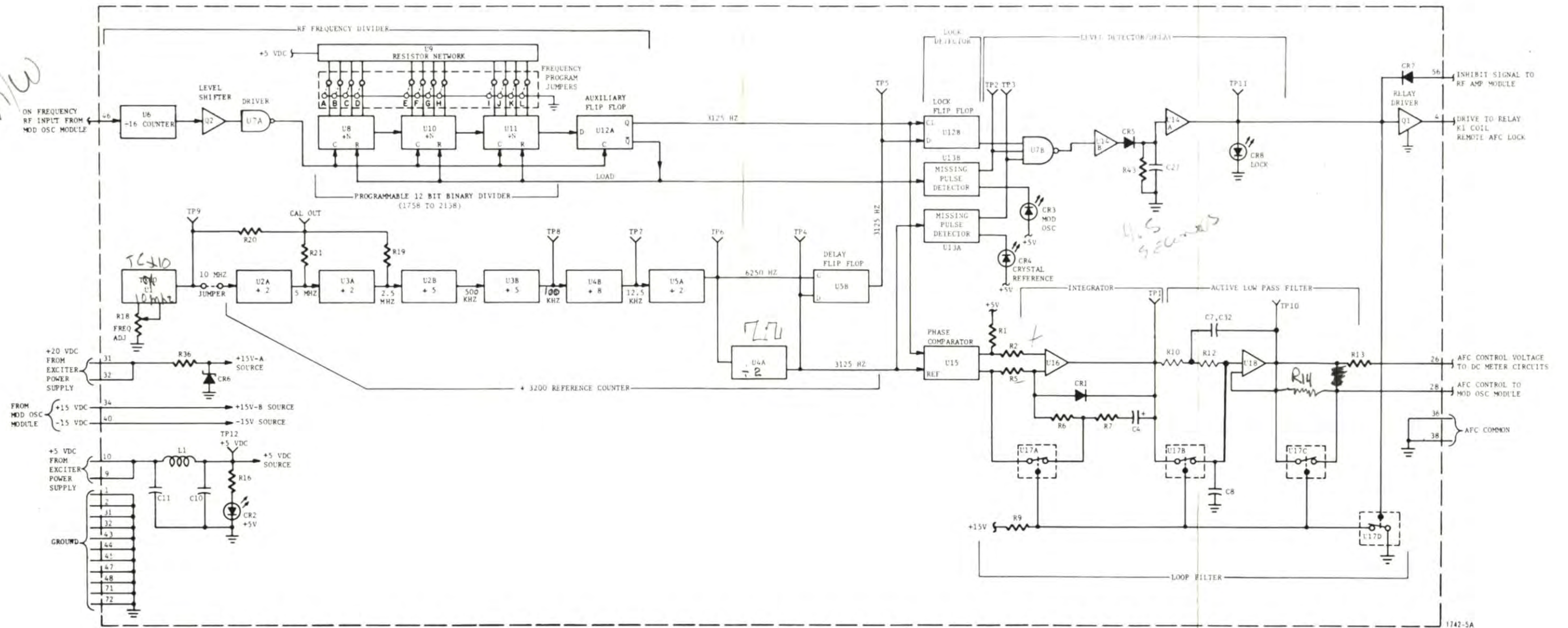

FIGURE 4-3. AFC/PLL MODULE DETAILED BLOCK DIAGRAM

subsequent TTL logic circuits. The signal is level shifted from ECL levels to TTL logic levels by Q2 and applied through NAND gate U7A which operates as an inverting buffer.

4-15. Programmable Divider. The output of U7A drives a 12 bit programmable divider consisting of U8, U10, and U11. The divider provides division from the approximate six MHz input to 3125 Hz by a programmable divisor from 1748 to 2158. The programmable counter allows use of any exciter rf output frequency from 87.5 MHz to 108.0 MHz in 50 kHz steps without modifying the reference divider chain or adjusting the TCXO. The counter is programmed by wire jumpers which by their absence connect the flip flop data inputs to positive five volts dc (ONE state) or when present short the inputs to ground (ZERO state). A complete list of exciter operating frequencies and divider programming is provided by table 4-1.

4-16. Programmable Divider Operation. When power is applied, the counter is set to the programmed number. When the counter fills to all ONES, the next clock pulse shifts a pulse out of the counter to auxiliary flip flop U12A. The next clock pulse shifts the pulse out of the auxiliary flip flop and resets the programmable counter to the number entered with the wire jumpers. The counter then begins its count again with the following clock pulse. The pulses output by the programmable divider are one clock period long (approximately 150 nanoseconds) at a 3125 Hz rate. The pulses are difficult but not impossible to see on an oscilloscope due to the very low duty cycle of 0.05%.

4-17. MISSING PULSE DETECTORS. The 3125 Hz signal from the rf frequency divider is applied to U13B and the 3125 Hz signal from the reference divider is applied to U13A. As long as each input pulse is repeatedly applied to the respective retriggerable one shot, the output will remain HIGH. If a missing pulse occurs in a divider chain, the one shot monitoring the signal will go LOW and signal a missing pulse. The MOD OSC indicator (CR3) and the CRYSTAL REFERENCE indicator (CR4) (inside the module) provide a visual indication of the status of each divider chain.

4-18. LOCK DETECTOR. The lock detector monitors the output of the two divider chains and indicates phase lock when the following three conditions are met. The reference divider chain must be operating properly, the rf frequency divider chain must be operating properly, and the phase difference between the two chains must be less than 90 degrees. After these three conditions are met for a five second delay, the lock detector will indicate a phase locked condition.

4-19. Lock Flip Flop. The output of the programmable divider clocks a type D flip flop which functions as the lock flip flop. The data input is obtained from the 90 degree delayed 3125 Hz squarewave from the reference divider. As long as the loop is in the locked condition, the narrow pulses from the programmable divider will occur close to the center of the delayed 3125 Hz squarewave as shown by figure 4-4. The phase detector characteristic causes the loop to lock on the negative transitions of the phase detector input signals.

3125 HZ FROM
REFERENCE DIVIDER

3125 HZ FROM
PROGRAMMABLE DIVIDER

DELAYED 3125 HZ
FROM REFERENCE DIVIDER

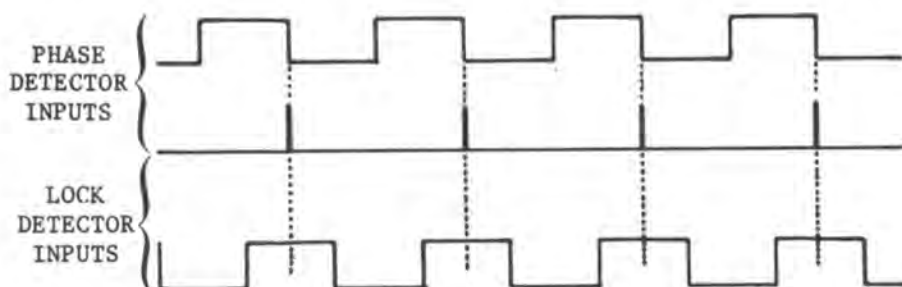

1742-54

Figure 4-4. Detector Waveforms

4-20. During lock, the lock flip flop outputs a continuous HIGH state. If the loop unlocks, the phase of the programmable divider waveform will drift with respect to the delayed 3125 Hz signal. When the programmable divider signal coincides with the LOW state of the delayed 3125 Hz signal, the lock flip flop will output a LOW state to signal a frequency unlocked condition.

4-21. LEVEL DETECTOR/DELAY. The output of the lock flip and the outputs from the missing pulse detectors are applied to NAND gate U7B. This signal is applied to a quick-charge slow-discharge circuit comprising U14A, U14B, CR5, C27, and R43. If a missing pulse is detected or if the lock detector flip flop output goes LOW, C27 is quickly charged and an out of lock condition is immediately signaled. After lock is achieved, a five second delay is required for capacitor C27 to discharge and allow the lock detector to recover and perceive lock. The output of the circuit controls illumination of the LOCK indicator, applies a ground to the RF AMP module to prevent off frequency transmission when the loop is unlocked, operates the remote AFC lock relay (K1), and operates the CMOS switches associated with the loop filter to control loop correction rates.

4-22. PHASE COMPARATOR. The phase comparator is a flip-flop type which has a three level output. If both the reference and controlled inputs have a zero phase difference between the negative transitions, the output will be zero with respect to the +1.4 Vdc. If the controlled input lags in phase, the phase comparator will output negative pulses with respect to +1.4 Vdc with the pulse width proportional to the angle of phase lag. If the controlled input leads in phase, the phase comparator will output positive pulses with respect to +1.4 Vdc with the pulse width proportional to the angle of phase lead. Additionally, if a frequency difference exists between the two inputs the phase comparator will respond by producing negative pulses if the controlled frequency is low and positive pulses if the controlled frequency is high. The pulses are integrated by U16 and filtered into a dc control signal by U18.

4-23. Bistable Loop. The integrator and active low-pass filter used in the module have bistable characteristics which reduce loop lock up time to a minimum. When the loop is unlocked, a CMOS switch arrangement operated by the level detector/delay output enables a high rate of correction by U16

FREQ JUMPERS				FREQ JUMPERS				FREQ JUMPERS				FREQ JUMPERS				FREQ JUMPERS				FREQ JUMPERS				FREQ JUMPERS							
MHZ	LKJI	HGFE	DCBA	MHZ	LKJI	HGFE	DCBA	MHZ	LKJI	HGFE	DCBA	MHZ	LKJI	HGFE	DCBA	MHZ	LKJI	HGFE	DCBA	MHZ	LKJI	HGFE	DCBA	MHZ	LKJI	HGFE	DCBA	MHZ	LKJI	HGFE	DCBA
87.50	1001	0010	1011	90.10	1000	1111	0111	92.70	1000	1100	0011	95.30	1000	1000	1111	97.90	1000	0101	1011	100.50	1000	0010	0111	103.10	0111	1111	0011	105.70	0111	1011	1111
87.55	1001	0010	1010	90.15	1000	1111	0110	92.75	1000	1100	0010	95.35	1000	1000	1110	97.95	1000	0101	1010	100.55	1000	0010	0110	103.15	0111	1111	0010	105.75	0111	1011	1110
87.60	1001	0010	1001	90.20	1000	1111	0101	92.80	1000	1100	0001	95.40	1000	1000	1101	98.00	1000	0101	1001	100.60	1000	0010	0101	103.20	0111	1111	0001	105.80	0111	1011	1101
87.65	1001	0010	1000	90.25	1000	1111	0100	92.85	1000	1100	0000	95.45	1000	1000	1100	98.05	1000	0101	1000	100.65	1000	0010	0100	103.25	0111	1111	0000	105.85	0111	1011	1100
87.70	1001	0010	0111	90.30	1000	1111	0011	92.90	1000	1011	1111	95.50	1000	1000	1011	98.10	1000	0101	0111	100.70	1000	0010	0011	103.30	0111	1110	1111	105.90	0111	1011	1011
87.75	1001	0010	0110	90.35	1000	1111	0010	92.95	1000	1011	1110	95.55	1000	1000	1010	98.15	1000	0101	0110	100.75	1000	0010	0010	103.35	0111	1110	1110	105.95	0111	1011	1010
87.80	1001	0010	0101	90.40	1000	1111	0001	93.00	1000	1011	1101	95.60	1000	1000	1001	98.20	1000	0101	0101	100.80	1000	0010	0001	103.40	0111	1110	1101	106.00	0111	1011	1001
87.85	1001	0010	0100	90.45	1000	1111	0000	93.05	1000	1011	1100	95.65	1000	1000	1000	98.25	1000	0101	0100	100.85	1000	0010	0000	103.45	0111	1110	1100	106.05	0111	1011	1000
87.90	1001	0010	0011	90.50	1000	1110	1111	93.10	1000	1011	1011	95.70	1000	1000	0111	98.30	1000	0101	0011	100.90	1000	0001	1111	103.50	0111	1110	1011	106.10	0111	1011	0111
87.95	1001	0010	0010	90.55	1000	1110	1110	93.15	1000	1011	1010	95.75	1000	1000	0110	98.35	1000	0101	0010	100.95	1000	0001	1110	103.55	0111	1110	1010	106.15	0111	1011	0110
88.00	1001	0010	0001	90.60	1000	1110	1101	93.20	1000	1011	1001	95.80	1000	1000	0101	98.40	1000	0101	0001	101.00	1000	0001	1101	103.60	0111	1110	1001	106.20	0111	1011	0101
88.05	1001	0010	0000	90.65	1000	1110	1100	93.25	1000	1011	1000	95.85	1000	1000	0000	98.45	1000	0101	0000	101.05	1000	0001	1100	103.65	0111	1110	1000	106.25	0111	1011	0100
88.10	1001	0001	1111	90.70	1000	1110	1011	93.30	1000	1011	0111	95.90	1000	1000	0011	98.50	1000	0100	1111	101.10	1000	0001	1011	103.70	0111	1110	0111	106.30	0111	1011	0011
88.15	1001	0001	1110	90.75	1000	1110	1010	93.35	1000	1011	0110	95.95	1000	1000	0010	98.55	1000	0100	1110	101.15	1000	0001	1010	103.75	0111	1110	0110	106.35	0111	1011	0010
88.20	1001	0001	1101	90.80	1000	1110	1001	93.40	1000	1011	0101	96.00	1000	1000	0001	98.60	1000	0100	1101	101.20	1000	0001	1001	103.80	0111	1110	0101	106.40	0111	1011	0001
88.25	1001	0001	1100	90.85	1000	1110	1000	93.45	1000	1011	0100	96.05	1000	1000	0000	98.65	1000	0100	1100	101.25	1000	0001	1000	103.85	0111	1110	0100	106.45	0111	1011	0000
88.30	1001	0001	1011	90.90	1000	1110	0111	93.50	1000	1011	0011	96.10	1000	0111	1111	98.70	1000	0100	1011	101.30	1000	0001	0111	103.90	0111	1110	0011	106.50	0111	1010	1111
88.35	1001	0001	1010	90.95	1000	1110	0110	93.55	1000	1011	0010	96.15	1000	0111	1110	98.75	1000	0100	1010	101.35	1000	0001	0110	103.95	0111	1110	0010	106.55	0111	1010	1110
88.40	1001	0001	1001	91.00	1000	1110	0101	93.60	1000	1011	0001	96.20	1000	0111	1101	98.80	1000	0100	1001	101.40	1000	0001	0101	104.00	0111	1110	0001	106.60	0111	1010	1101
88.45	1001	0001	1000	91.05	1000	1110	0100	93.65	1000	1011	0000	96.25	1000	0111	1100	98.85	1000	0100	1000	101.45	1000	0001	0100	104.05	0111	1110	0000	106.65	0111	1010	1100
88.50	1001	0001	0111	91.10	1000	1110	0011	93.70	1000	1010	1111	96.30	1000	0111	1011	98.90	1000	0100	0111	101.50	1000	0001	0011	104.10	0111	1101	1111	106.70	0111	1010	1011
88.55	1001	0001	0110	91.15	1000	1110	0010	93.75	1000	1010	1110	96.35	1000	0111	1010	98.95	1000	0100	0110	101.55	1000	0001	0010	104.15	0111	1101	1110	106.75	0111	1010	1010
88.60	1001	0001	0101	91.20	1000	1110	0001	93.80	1000	1010	1101	96.40	1000	0111	1001	99.00	1000	0100	0101	101.60	1000	0001	0001	104.20	0111	1101	1101	106.80	0111	1010	1001
88.65	1001	0001	0100	91.25	1000	1110	0000	93.85	1000	1010	1100	96.45	1000	0111	1000	99.05	1000	0100	0100	101.65	1000	0001	0000	104.25	0111	1101	1100	106.85	0111	1010	1000
88.70	1001	0001	0011	91.30	1000	1101	1111	93.90	1000	1010	1011	96.50	1000	0111	0111	99.10	1000	0100	0011	101.70	1000	0000	1111	104.30	0111	1101	1011	106.90	0111	1010	0111
88.75	1001	0001	0010	91.35	1000	1101	1110	93.95	1000	1010	1010	96.55	1000	0111	0110	99.15	1000	0100	0010	101.75	1000	0000	1110	104.35	0111	1101	1010	106.95	0111	1010	0110
88.80	1001	0001	0001	91.40	1000	1101	1101	94.00	1000	1010	1001	96.60	1000	0111	0101	99.20	1000	0100	0001	101.80	1000	0000	1101	104.40	0111	1101	1001	107.00	0111	1010	0101
88.85	1001	0001	0000	91.45	1000	1101	1100	94.05	1000	1010	1000	96.65	1000	0111	0100	99.25	1000	0100	0000	101.85	1000	0000	1100	104.45	0111	1101	1000	107.05	0111	1010	0100
88.90	1001	0000	1111	91.50	1000	1101	1011	94.10	1000	1010	0111	96.70	1000	0111	0011	99.30	1000	0011	1111	101.90	1000	0000	1011	104.50	0111	1101	0111	107.10	0111	1010	0011
88.95	1001	0000	1110	91.55	1000	1101	1010	94.15	1000	1010	0110	96.75	1000	0111	0010	99.35	1000	0011	1110	101.95	1000	0000	1010	104.55	0111	1101	0110	107.15	0111	1010	0010
89.00	1001	0000	1101	91.60	1000	1101	1001	94.20	1000	1010	0101	96.80	1000	0111	0001	99.40	1000	0011	1101	102.00	1000	0000	1001	104.60	0111	1101	0101	107.20	0111	1010	0001
89.05	1001	0000	1100	91.65	1000	1101	1000	94.25	1000	1010	0100	96.85	1000	0111	0000	99.45	1000	0011	1100	102.05	1000	0000	1000	104.65	0111	1101	0100	107.25	0111	1010	0000
89.10	1001	0000	1011	91.70	1000	1101	0111	94.30	1000	1010	0011	96.90	1000	0110	1111	99.50	1000	0011	1101	102.10	1000	0000	0111	104.70	0111	1101	0011	107.30	0111	1001	1111
89.15	1001	0000	1010	91.75	1000	1101	0110	94.35	1000	1010	0010	96.95	1000	0110	1110	99.55	1000	0011	1010	102.15	1000	0000	0110	104.75	0111	1101	0010	107.35	0111	1001	1110
89.20	1001	0000	1001	91.80	1000	1101	0101	94.40	1000	1010	0001	97.00	1000	0110	1101	99.60	1000	0011	1001	102.20	1000	0000	0101	104.80	0111	1101	0001	107.40	0111	1001	1101
89.25	1001	0000	1000	91.85	1000	1101	0100	94.45	1000	1010	0000	97.05	1000	0110	1100	99.65	1000	0011	1000	102.25	1000	0000	0100	104.85	0111	1101	0000	107.45	0111	1001	1100
89.30	1001	0000	0111	91.90	1000	1101	0011	94.50	1000	1001	1111	97.10	1000	0110	1011	99.70	1000	0011	0111	102.30	1000	0000	0011	104.90	0111	1100	1111	107.50	0111	1001	1011
89.35	1001	0000	0110	91.95	1000	1101	0010	94.55	1000	1001	1110	97.15	1000	0110	1010	99.75	1000	0011	0110	102.35	1000	0000	0010	104.95	0111	1100	1110	107.55	0111	1001	1010
89.40	1001	0000	0101	92.00	1000	1101	0001	94.60	1000	1001	1101	97.20	1000	0110	1001	99.80	1000	0011	0101	102.40	1000	0000	0001	105.00	0111	1100	1101	107.60	0111	1001	1001
89.45	1001	0000	0100	92.05	1000	1101	0000	94.65	1000	1001	1100	97.25																			

and bypasses low-pass filter U18. When the lock detector/delay detects lock, the gain of U16 is reduced and low-pass filter U18 is connected in the signal path. The output provides control voltage to the MOD OSC module VCO assembly for frequency correction. An additional output to the dc meter circuit provides an indication of the dc output control voltage which usually ranges from positive three volts to +12 Vdc.

4-24. POWER. An input of positive five volts dc from the exciter power supply is internally filtered to operate the logic circuitry. The +5V indicator provides an indication of the operation of the five volt source. An additional input of +20 Vdc applied through R36 is stabilized by zener diode CR6 to provide +15 volt potential. Re-regulated +15 Vdc inputs from the MOD OSC module provide +15 Vdc potentials to operate the AFC/PLL MODULE loop filter circuit.

SECTION V

MAINTENANCE

5-1. CORRECTIVE MAINTENANCE

5-2. The MS-15 FM Exciter module maintenance philosophy consists of problem isolation to a specific area or individual component and subsequent isolation and replacement of the defective component.

5-3. TROUBLESHOOTING

5-4. In event of problems, the trouble area must first be isolated to a specific area. Most troubleshooting consists of visual checks. The MODULATION meter, MULTIMETER, fuse F1, circuit breaker CBI, and the indicators on each module should be used to determine in which area the malfunction exists. All module power supplies are equipped with LEDs which indicate a problem associated with an individual module monolithic voltage regulator. A consistent pattern of dark LEDs however, would indicate an exciter dc distribution bus fault.

5-5. Once the trouble is isolated to a specific area, refer to the theory section of this manual for circuit discussion to aid in problem resolution. Table 5-1 lists typical trouble symptoms pertaining to the individual module operation with references to fault isolation diagrams listing probable causes and corrective actions. A corrective action given for a trouble symptom is not necessarily the only answer to a problem. It only tends to lead the repairman into the area that may be causing the trouble. An extender board (HARRIS PN 992 4989 001) is provided with the exciter to assist in troubleshooting. In event parts are required, refer to Section VI, Parts List. The following information is contained in this section as an aid to maintenance:

<u>REFERENCE</u>	<u>TITLE</u>	<u>NUMBER</u>
Figure 5-1	AFC/PLL MODULE Parts Layout	--- ---- ---
Table 5-2	AFC/PLL MODULE Parts Index	--- ---- ---
Figure 5-2	AFC/PLL MODULE Waveforms	--- ---- ---
Figure 5-3	AFC/PLL MODULE Schematic	852 8394 001

Table 5-1. AFC/PLL MODULE Fault Isolation Index

SYMPTOM	DEFECT/REFERENCE
LOOP WILL NOT LOCK (LOCK indicator out).	Figure 5-4
LOOP LOCKS ON INCORRECT FREQUENCY (LOCK indicator illuminated).	Figure 5-5
NOISE	Figure 5-6
3125 HZ WHINE	Figure 5-7
SLOW WAVERING OF FREQUENCY (LOCK indicator illuminated).	Figure 5-8
LOOP LOCKS THEN QUICKLY UNLOCKS	Figure 5-9
OUTPUT OFF FREQUENCY	Refer to table 3-2 and adjust the FREQ ADJ Control.

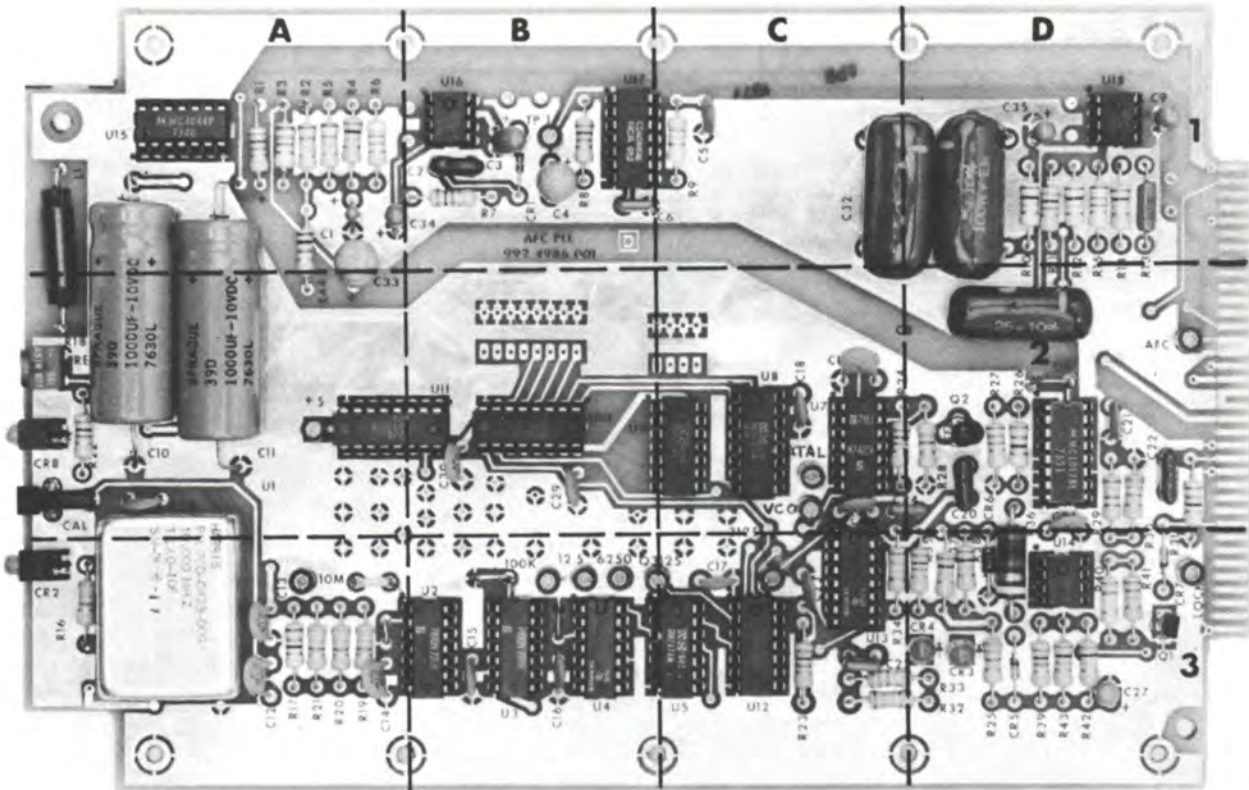

1742-33

Figure 5-1. AFC/PLL MODULE Parts Layout

Table 5-2. AFC/PLL MODULE Parts Index

SYMBOL	LOCATION	SYMBOL	LOCATION	SYMBOL	LOCATION	SYMBOL	LOCATION	SYMBOL	LOCATION
C1	A1	C29	B2	L1	A1	R19	A3		
C2	B1	C30	B2			R20	A3		
C3	B1	C31	C2			R21	A3		
C4	B1	C32	C1			R22	A2		
C5	C1	C33	A2	Q1	D3	R23	C3		
C6	C1	C34	B1	Q2	D2	R24	C2		
C7	D1	C35	D1			R25	D3		
C8	D2					R26	D2		
C9	D1					R27	D2		
C10	A2					R28	D2		
C11	A2			R1	A1	R29	D2		
C12	A3			R2	A1	R30	D2		
C13	A3			R3	A1	R31	D2		
C14	A3			R4	A1	R32	D3		
C15	B3	CR1	B1	R5	A1	R33	D3		
C16	B3	CR2	A3	R6	A1	R34	C3		
C17	C3	CR3	D3	R7	B1	R35	D3		
C18	C2	CR4	D3	R8	B1	R36	D3		
C19	C2	CR5	D2	R9	C1	R37	D3		
C20	D2	CR6	D3	R10	D1	R38	D3		
C21	D2	CR7	A2	R11	D1	R39	D3		
C22	D2	CR8		R12	D1	R40	D3		
C23	C3			R13	D1	R41	D3		
C24	D2			R14	D1	R42	D3		
C25	C3			R15	D1	R43	D3		
C26	D2			R16	A3	R44	A2		
C27	D3			R17	A3				
C28	A2			R18	A2				

Table 5-2. AFC/PLL MODULE Parts Index (Continued)

SYMBOL	LOCATION	SYMBOL	LOCATION	SYMBOL	LOCATION	SYMBOL	LOCATION
U1	A3						
U2	B3						
U3	B3						
U4	B3						
U5	C3						
U6	D2						
U7	C2						
U9	C2						
U9	B2						
U10	B2						
U11	B2						
U12	C3						
U13	C3						
U14	D3						
U15	A1						
U15	B1						
U17	B1						
U18	D1						

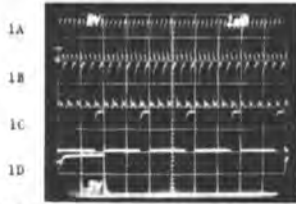

TEST REQUIREMENTS: A. Oscilloscope synchronized to U3 pin 11.

- 1A Reference counter waveform at U2 pin 12 (5 MHz).
- 1B Reference counter waveform at U3 pin 13 (2.5 MHz).
- 1C Reference counter waveform at U2 pin 11 (500 kHz).
- 1D Reference counter waveform at U3 pin 11 (100 kHz).

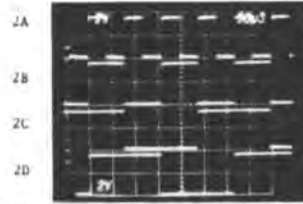

TEST REQUIREMENTS: A. Oscilloscope synchronized to test point TP4.

- 2A Reference counter waveform at test point TP7 (12.5 kHz).
- 2B Reference counter waveform at test point TP6 (6250 Hz).
- 2C Reference counter waveform at test point TP4 (3125 Hz).
- 2D Reference counter waveform at test point TP5 (3125 Hz delayed 90°).

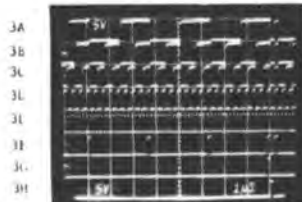

TEST REQUIREMENTS: A. Oscilloscope adjusted for delayed sweep display and synchronized to U12 pin 9.

B. Exciter frequency set to 96.6 MHz. (Other channels will yield similar, but not identical waveforms.)

- 3A Synchronous programmable divider waveform at U8 pin 13.
- 3B Synchronous programmable divider waveform at U8 pin 12.
- 3C Synchronous programmable divider waveform at U8 pin 11.
- 3D Synchronous programmable divider waveform at U8 pin 10.
- 3E Synchronous programmable divider clock at U8 pin 2, U10 pin 2, U11 pin 2, or U12 pin 11.
- 3F Synchronous programmable divider ripple carry at U8 pin 15.
- 3G Synchronous programmable divider ripple carry at U11 pin 15.
- 3H Synchronous programmable divider output at U12 pin 9.

1742-76

Figure 5-2. AFC/PLL MODULE Waveforms



TEST REQUIREMENTS: A. Oscilloscope synchronized to test point TP4.

- 4A Phase detector waveform at U15 pins 5 and 10 with VCO lagging in phase.
- 4B Phase detector waveform at U15 pins 5 and 10 with VCO lagging in phase.
- 4C 3125 Hz reference at U15 pin 1.

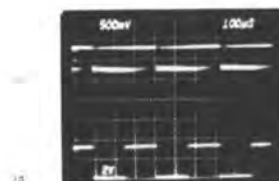

TEST REQUIREMENTS: A. Oscilloscope synchronized to test point TP4.

- 5A Phase detector waveform at U15 pins 5 and 10 with the VCO frequency too high.
- 5B 3125 Hz reference at U15 pin 1.

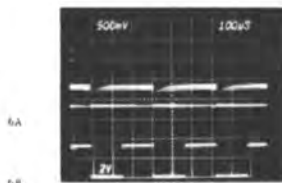

TEST REQUIREMENTS: A. Oscilloscope synchronized to test point TP4.

- 6A Phase detector waveform at U15 pins 5 and 10 with the VCO frequency too low.
- 6B 3125 Hz reference at U15 pin 1.

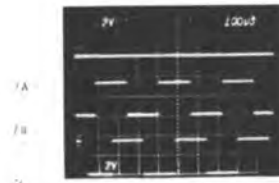

TEST REQUIREMENTS: A. Oscilloscope synchronized to test point TP4.

- 7A Programmable divider output at U12 pin 9.
- 7B Lock detector waveform at U4 pin 12 (3125 Hz reference).
- 7C Lock detector waveform at U5 pin 5 (3125 Hz delayed 90°).

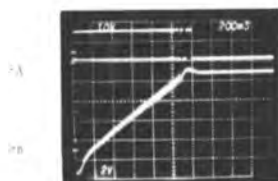

TEST REQUIREMENTS: A. Oscilloscope adjusted for single sweep.

B. Power off. Sweep starts when exciter power is applied.

- 8A Lockup waveform at U14 pin 1 (lock detector).
- 8B Lockup waveform at U18 pin 6 (AFC voltage).

1742-77

Figure 5-2. AFC/PLL MODULE Waveforms (Continued)

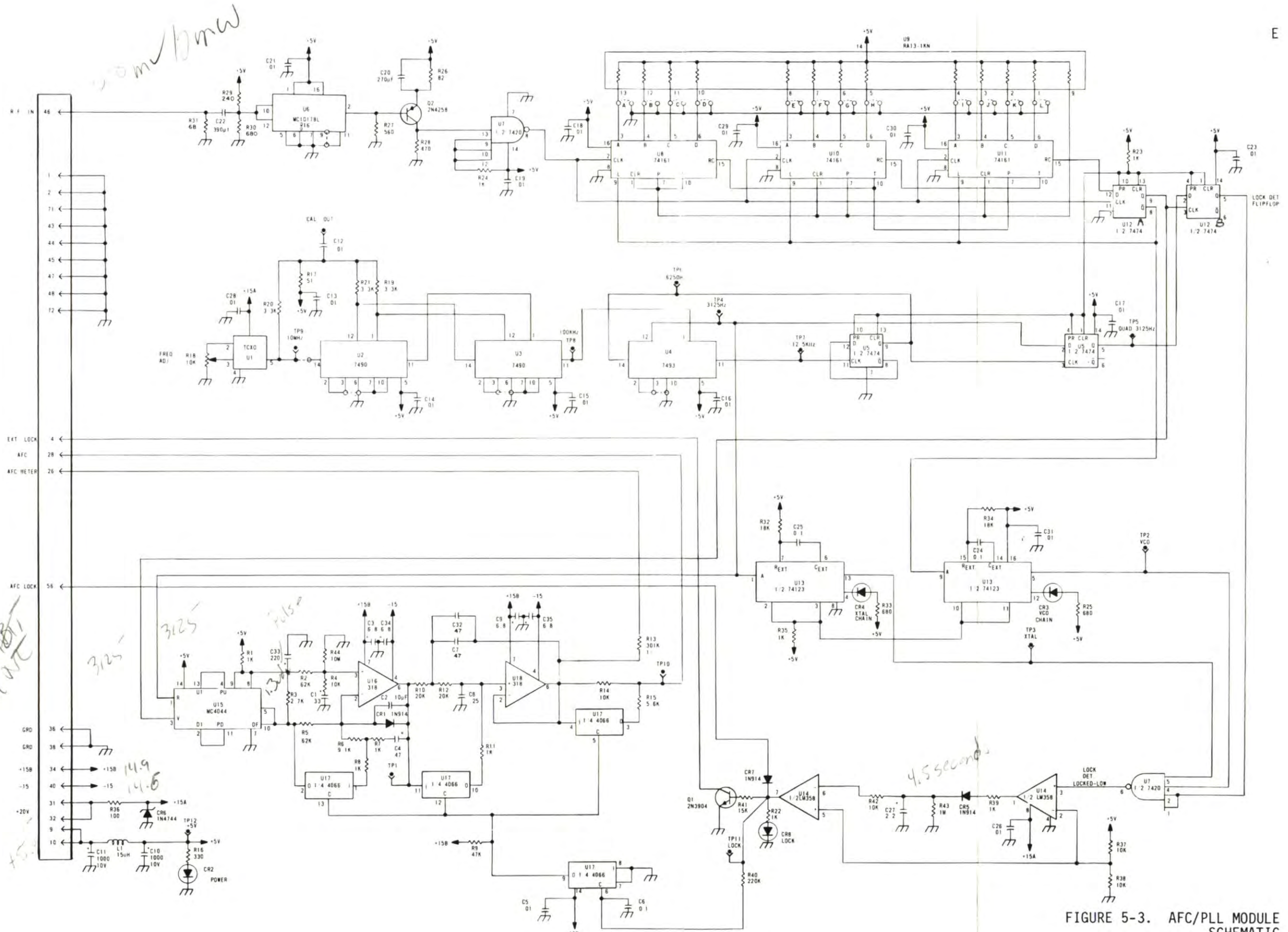

Handwritten: BP
TUNING
UNIT

FIGURE 5-3. AFC/PLL MODULE SCHEMATIC 852 8394 001

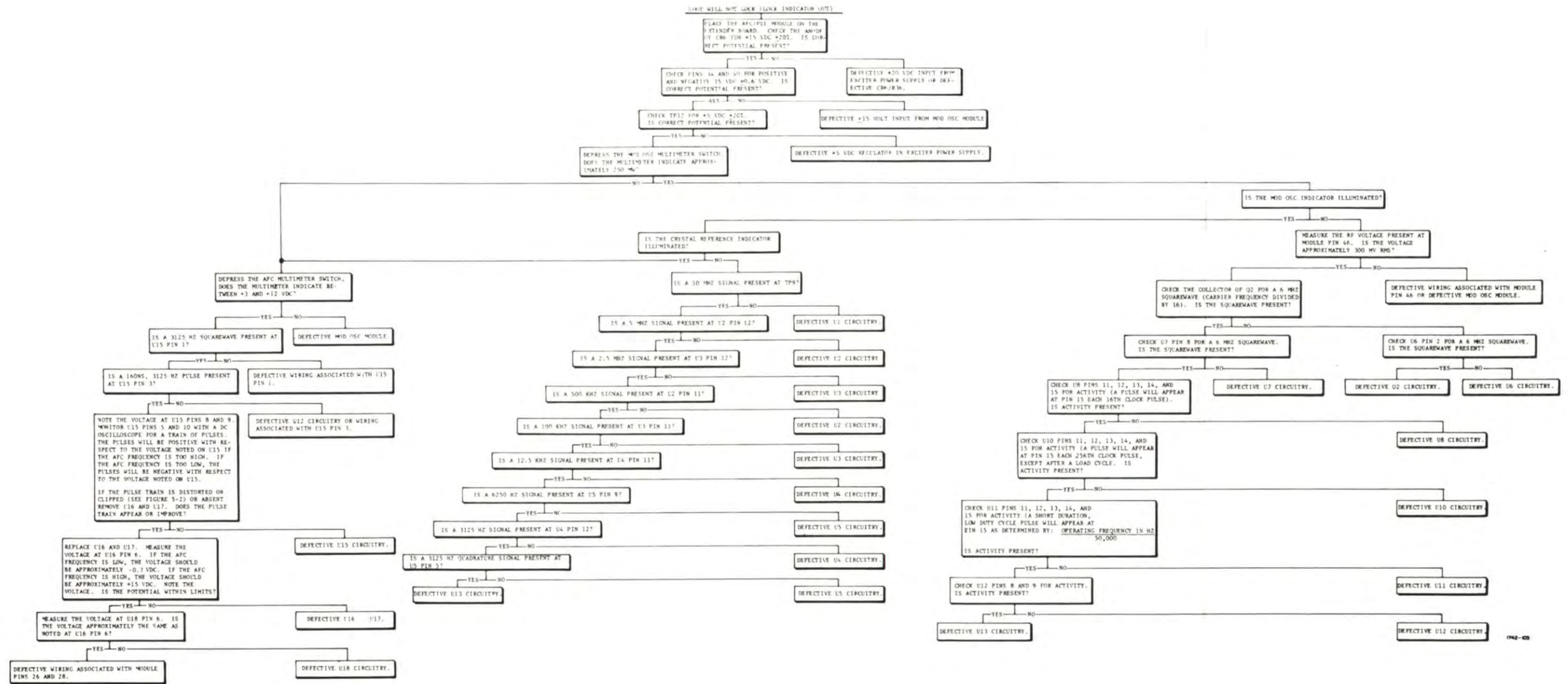

FIGURE 5-4. LOOP WILL NOT LOCK (LOCK INDICATOR OUT)

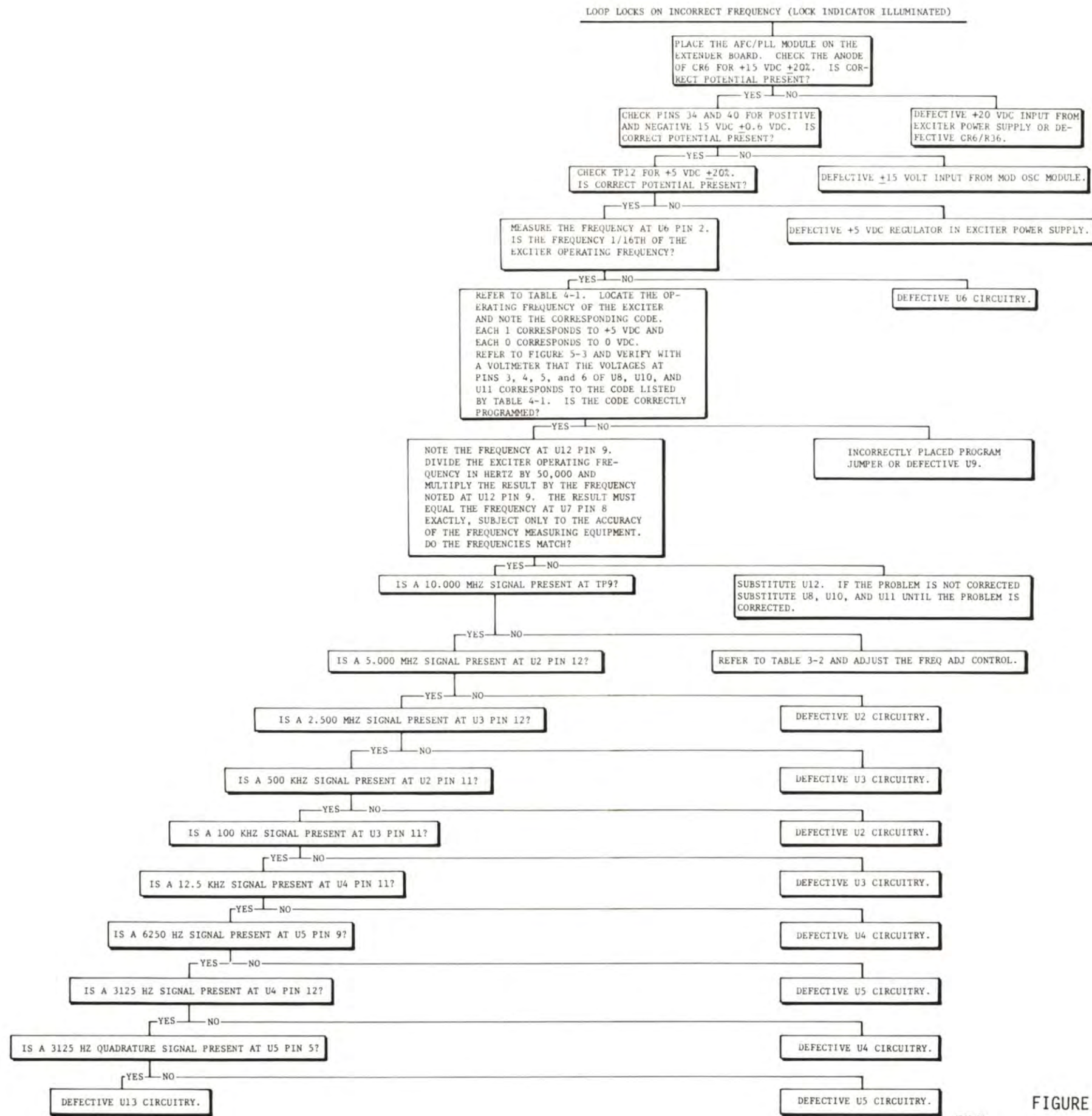
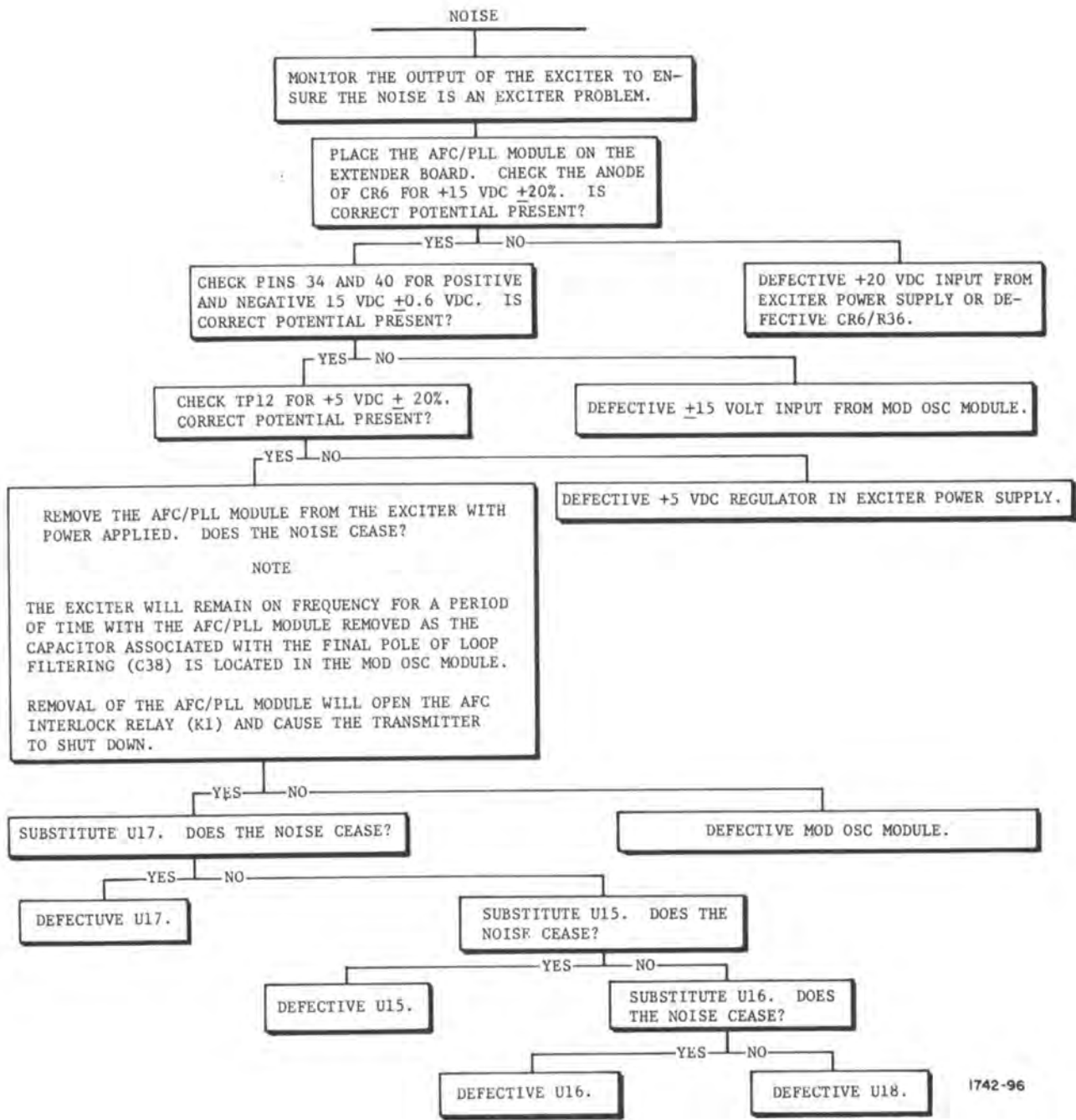

FIGURE 5-5. LOOP LOCKS ON INCORRECT FREQUENCY (LOCK INDICATOR ILLUMINATED)

1742-99



1742-96

Figure 5-6. Noise

3125 HZ WHINE.

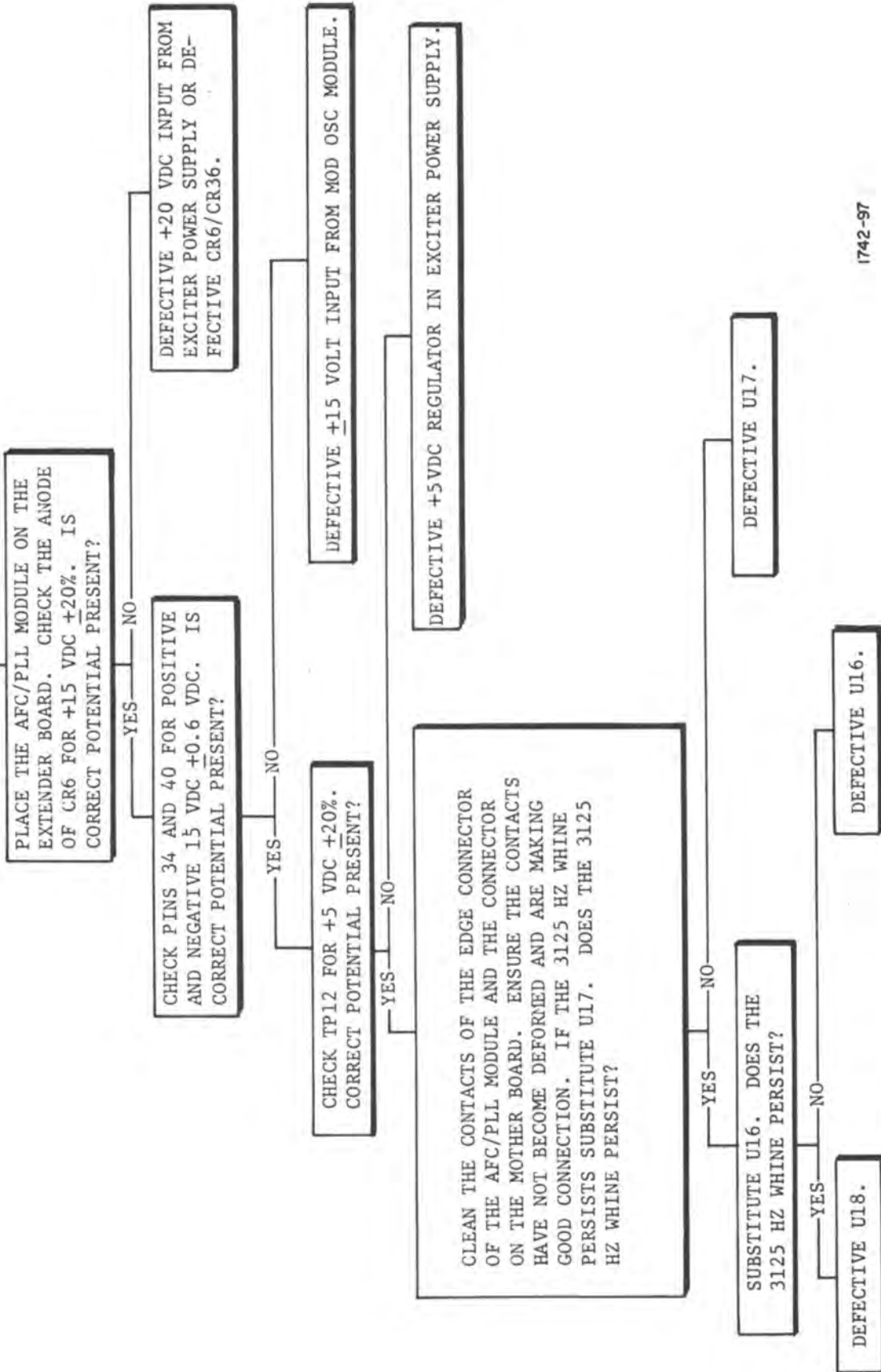

1742-97

Figure 5-7. 3125 Hz Whine

SLOW WAVERING OF FREQUENCY (LOCK INDICATOR ILLUMINATED).

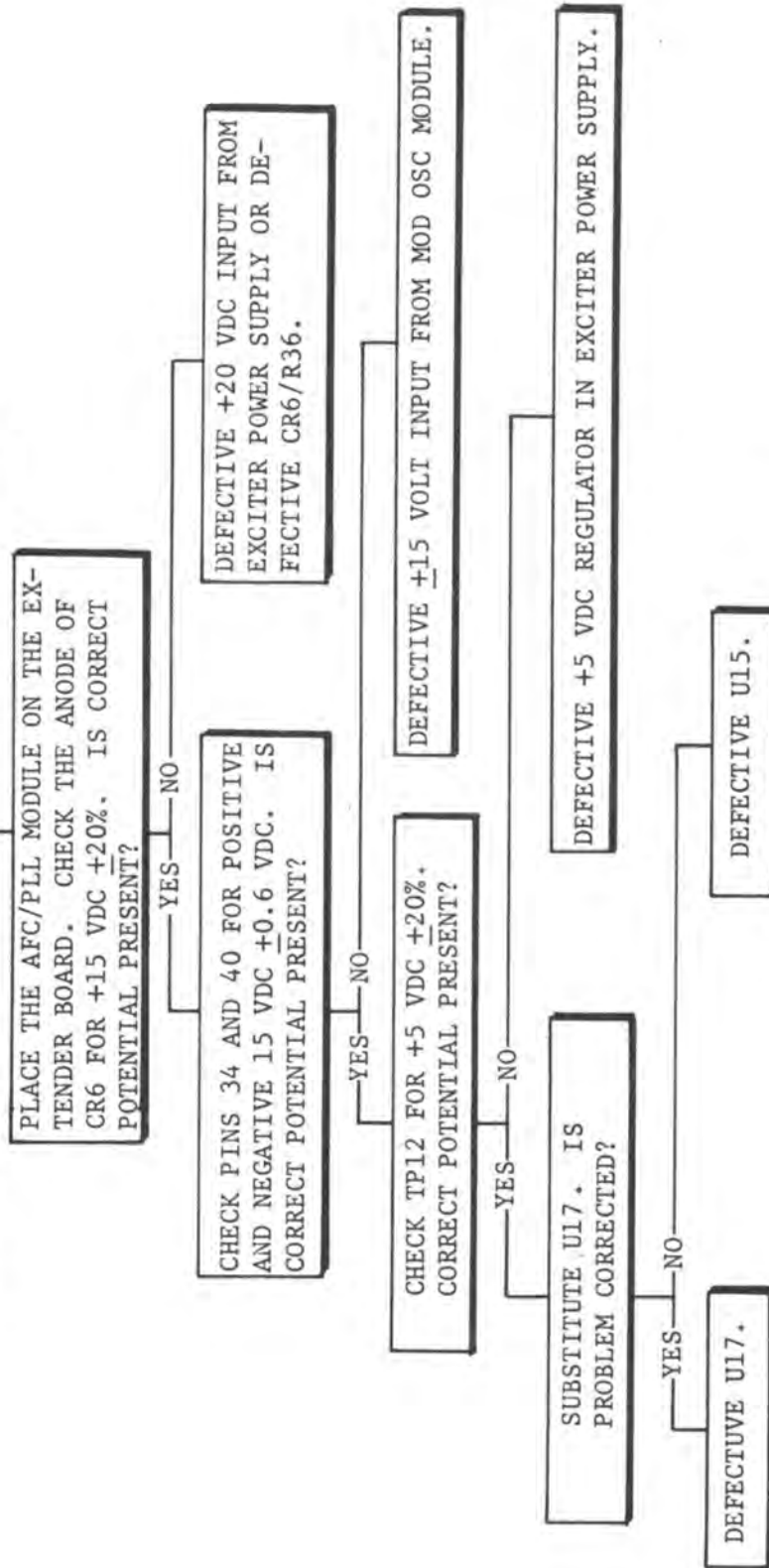

1742-95

Figure 5-8. Slow Wavering of Frequency (Lock Indicator Illuminated)

LOOP LOCKS THEN QUICKLY UNLOCKS.

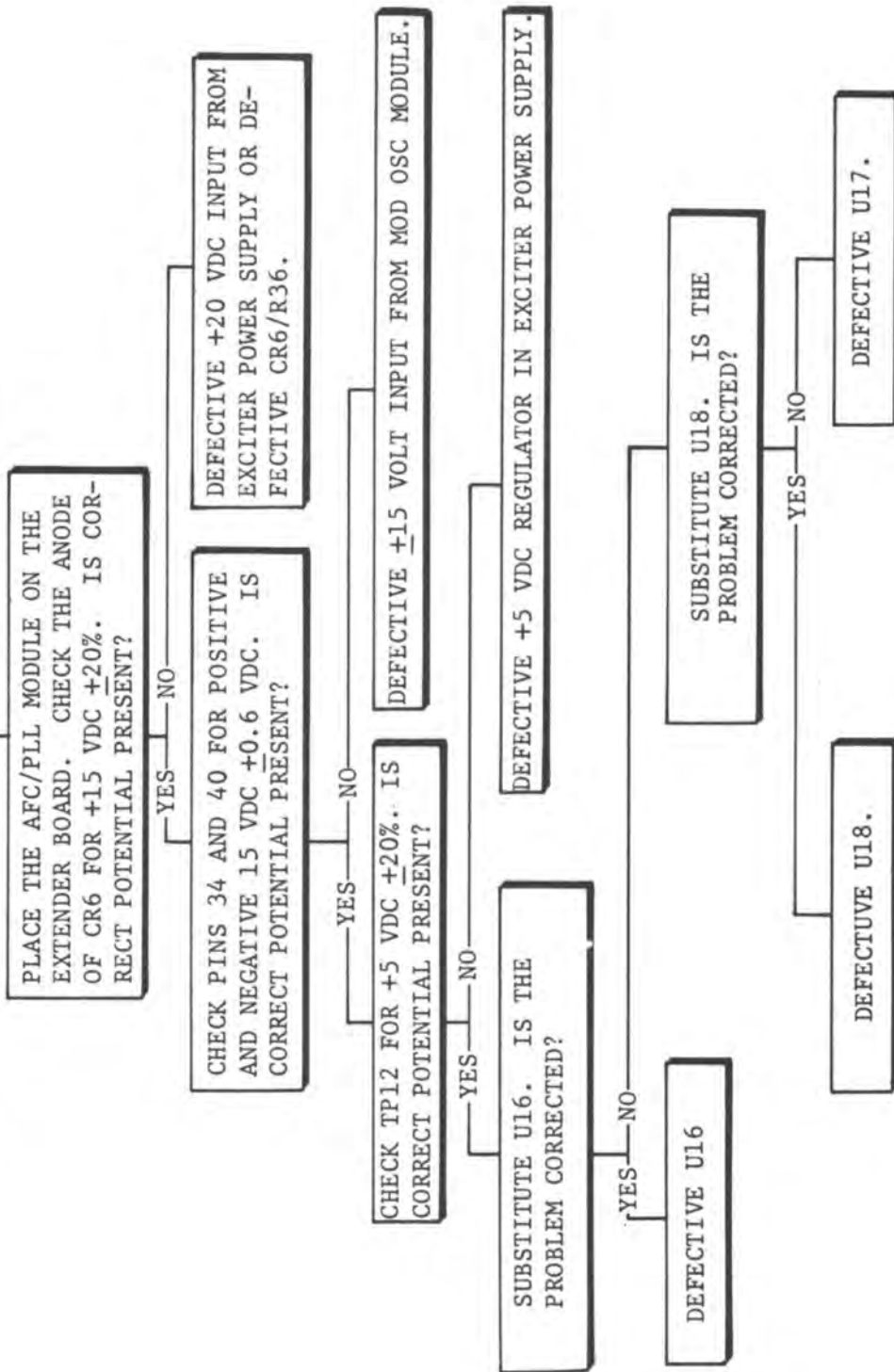

1742-92

Figure 5-9. Loop Locks Then Quickly Unlocks

SECTION VI

PARTS LIST

6-1. GENERAL

6-2. Refer to table 6-1 for replaceable parts which are required for proper maintenance of the MS-15 AFC/PLL module. Table entries are indexed by component reference designator.

Table 6-1. AFC/PLL MODULE Front Panel - 992 4985 001

REF. SYMBOL	HARRIS PART NO.	DESCRIPTION	QTY.
-----	992 4986 001	AFC/PLL MODULE Circuit Board (Refer to table 6-2)	1

Table 6-2. AFC/PLL MODULE Circuit Board - 992 4986 001

REF. SYMBOL	HARRIS PART NO.	DESCRIPTION	QTY.
C1	526 0331 000	Capacitor, 0.33 uF, 35V, 20%	1
C2	500 0804 000	Capacitor, 10 pF, 500V, Mica	1
C3	526 0049 000	Capacitor, 6.8 uF, 35V, 20%	1
C4	526 0359 000	Capacitor, 47 uF, 20V, 10%	1
C5	516 0375 000	Capacitor, 0.01 uF, 50V	1
C6	516 0484 000	Capacitor, 0.1 uF, 100V, 10%	1
C7	508 0336 000	Capacitor, 0.5 uF, 100V, 10%	1
C8	508 0280 000	Capacitor, 0.25 uF, 100V, 10%	1
C9	526 0049 000	Capacitor, 6.8 uF, 35V, 20%	1
C10,C11	522 0422 000	Capacitor, 1000 uF, 10V	2
C12 thru C19	516 0375 000	Capacitor, 0.01 uF, 50V	8
C20	500 0755 000	Capacitor, 270 pF, Mica, 500V	1
C21	516 0375 000	Capacitor, 0.01 uF, 50V	1
C22	500 0833 000	Capacitor, 390 pf, 500V, Mica, 5%	1
C23	516 0375 000	Capacitor, 0.01 uF, 50V	1
C24,C25	516 0484 000	Capacitor 0.1 uF, 100V, 10%	2
C26	516 0375 000	Capacitor, 0.01 uF, 50V	1
C27	526 0311 000	Capacitor, 2.2 uF, 35V, 20%	1
C28 thru C31	516 0375 000	Capacitor, 0.01 uF, 50V	4
C32	508 0336 000	Capacitor, 0.5 uF, 100V, 10%	1
C33	526 0047 000	Capacitor, 220 uF, 10V, 20%	1
C34,C35	526 0049 000	Capacitor, 6.8 uF, 35V, 20%	2

Table 6-2. AFC/PLL MODULE Circuit Board - 992 4986 001 (Continued)

REF. SYMBOL	HARRIS PART NO.	DESCRIPTION	QTY.
CR1	384 0205 000	Diode, Silicon, 1N914	1
CR2	384 0661 000	LED, Green	1
CR3,CR4	384 0610 000	LED, Green	2
CR5	384 0205 000	Diode, Silicon, 1N914	1
CR6	386 0092 000	Diode, Zener, 1N4744	1
CR7	387 0205 000	Diode, Silicon, 1N914	1
CR8	384 0664 000	LED, Yellow	1
L1	494 0436 000	Inductor, 15 uH	1
Q1	380 0189 000	Transistor, 2N3904	1
Q2	380 0421 000	Transistor, 2N4258	1
R1	540 1116 000	Resistor, 1000 ohm, 1/2W, 5%	1
R2	540 1222 000	Resistor, 62k ohm, 1/2W, 5%	1
R3	540 1156 000	Resistor, 2700k ohm, 1/2W, 5%	1
R4	540 1111 000	Resistor, 10k ohm, 1/2W, 5%	1
R5	540 1222 000	Resistor, 62k ohm, 1/2W, 5%	1
R6	540 1189 000	Resistor, 9100 ohm, 1/2W, 5%	1
R7,R8	540 1116 000	Resistor, 1000 ohm, 1/2W, 5%	2
R9	540 1122 000	Resistor, 47k ohm, 1/2W, 5%	1
R10	540 1107 000	Resistor, 20k ohm, 1/2W, 5%	1
R11	540 1116 000	Resistor, 1000 ohm, 1/2W, 5%	1
R12	540 1107 000	Resistor, 20k ohm, 1/2W, 5%	1
R13	548 0317 000	Resistor, 301k ohm, 1/4W, 1%	1

Table 6-2. AFC/PLL MODULE Circuit Board - 992 4986 001 (Continued)

REF. SYMBOL	HARRIS PART NO.	DESCRIPTION	QTY.
R14	540 1111 000	Resistor, 10k ohm, 1/2W, 5%	1
R15	540 1183 000	Resistor, 5600 ohm, 1/2W, 5%	1
R16	540 1216 000	Resistor 330 ohm, 1/2W 5%	1
R17	540 1192 000	Resistor, 51 ohm, 1/2W, 5%	1
R18	550 0914 000	Potentiometer, 10k ohm	1
R19,R20,R21	540 1165 000	Resistor, 3300 ohm, 1/2W, 5%	3
R22,R23,R24	540 1116 000	Resistor, 1000 ohm, 1/2W, 5%	3
R25	540 1181 000	Resistor, 680 ohm, 1/2W, 5%	1
R26	540 1225 000	Resistor, 82 ohm, 1/2W, 5%	1
R27	540 1191 000	Resistor, 560 ohm, 1/2W, 5%	1
R28	540 1115 000	Resistor, 470 ohm, 1/2W, 5%	1
R29	540 1190 000	Resistor, 240 ohm, 1/2W, 5%	1
R30	540 1181 000	Resistor, 680 ohm, 1/2W, 5%	1
R31	540 1110 000	Resistor, 68 ohm, 1/2W, 5%	1
R32	540 1113 000	Resistor, 18k ohm, 1/2W, 5%	1
R33	540 1181 000	Resistor, 680 ohm, 1/2W, 5%	1
R34	540 1113 000	Resistor, 18k ohm, 1/2W, 5%	1
R35	540 1116 000	Resistor, 1000 ohm, 1/2W, 5%	1
R36	540 0308 000	Resistor, 100 ohm, 1W, 5%	1
R37,R38	540 1111 0000	Resistor, 10k ohm, 1/2W, 5%	2
R39	540 1116 000	Resistor, 1000 ohm, 1/2W, 5%	1
R40	540 1212 000	Resistor, 220k ohm, 1/2W, 5%	1

Table 6-2. AFC/PLL MODULE Circuit Board - 992 4986 001 (Continued)

REF. SYMBOL	HARRIS PART NO.	DESCRIPTION	QTY.
R41	540 1184 000	Resistor, 15k ohm, 1/2W, 5%	1
R42	540 1111 000	Resistor, 10k ohm, 1/2W, 5%	1
R43	540 1162 000	Resistor, 1 Megohm, 1/2W, 5%	1
R44	540 1322 000	Resistor, 10 Megohm, 1/2W, 10%	1
U1	700 0423 000	Oscillator, Crystal, 10 MHz	1
U2,U3	382 0162 000	Integrated Circuit, N7490N	2
U4	382 0034 000	IC, SN7493AN, Texas Instrument Only	1
U5	382 0121 000	Integrated Circuit, DM7474N	1
U6	382 0541 000	Integrated Circuit, MC10178L	1
U7	382 0082 000	Integrated Circuit, MC7420P	1
U8	382 0532 000	Integrated Circuit, DM74161AN	1
U9	540 1331 000	Resistor, Network, 1k ohm, 2%	1
U10,U11	382 0532 000	Integrated Circuit, SN74161N	2
U12	382 0121 000	Integrated Circuit, DM7474N	1
U13	382 0148 000	Integrated Circuit, SN74123N	1
U14	382 0428 000	Integrated Circuit, LN358N	1
U15	382 0174 000	Integrated Circuit, MC4044P	1
U16	382 0472 000	Integrated Circuit, LM318N	1
U17	382 0523 000	Integrated Circuit, MC14066BCP	1
U18	382 0472 000	Integrated Circuit, LM318N	1
XU2 thru XU5	404 0674 000	Socket, IC, 14 Contact	4
XU6	404 0675 000	Socket, IC, 16 Contact	1

Table 6-2. AFC/PLL MODULE Circuit Board - 992 4986 001 (Continued)

REF. SYMBOL	HARRIS PART NO.	DESCRIPTION	QTY.
XU7	404 0674 000	Socket, IC, 14 Contact	1
XU8	404 0675 000	Socket, IC, 16 Contact	1
XU9	404 0674 000	Socket, IC, 14 Contact	1
XU10,XU11	404 0675 000	Socket, IC, 16 Contact	2
XU12	404 0674 000	Socket, IC, 14 Contact	1
XU13	404 0675 000	Socket, IC, 16 Contact	1
XU14	404 0673 000	Socket, IC, 8 Contact	1
XU15	404 0674 000	Socket, IC, 14 Contact	1
XU16	404 0673 000	Socket, IC, 8 Contact	1
XU17	404 0674 000	Socket, IC, 14 Contact	1
XU18	404 0673 000	Socket, IC, 8 Contact	1
	610 0750 000	Test Probe, Type C	1
	612 0890 000	Test Jack, Vertical Printed Circuit Mount	12
	843 1800 001	Printed Board	1

MOD OSC MODULE

TECHNICAL MANUAL

MOD OSC MODULE

994 4987 001



HARRIS CORPORATION

Broadcast Products Division

T.M. No. 888-1742-008

Printed: October 1977
Revision A: February 1978
Revision B: August 1978
Revision C: March 1979
Revision D: April 1980
Revision E: March 1980
Revision F: June 1981

WARNING

THE CURRENTS AND VOLTAGES IN THIS EQUIPMENT ARE DANGEROUS. PERSONNEL MUST AT ALL TIMES OBSERVE SAFETY REGULATIONS.

This manual is intended as a general guide for trained and qualified personnel who are aware of the dangers inherent in handling potentially hazardous electrical/electronic circuits. It is not intended to contain a complete statement of all safety precautions which should be observed by personnel in using this or other electronic equipment.

The installation, operation, maintenance and service of this equipment involves risks both to personnel and equipment, and must be performed only by qualified personnel exercising due care. HARRIS CORPORATION shall not be responsible for injury or damage resulting from improper procedures or from the use of improperly trained or inexperienced personnel performing such tasks.

During installation and operation of this equipment, local building codes and fire protection standards must be observed. The following National Fire Protection Association (NFPA) standards are recommended as references:

- Automatic Fire Detectors, No. 72E
- Installation, Maintenance, and Use of Portable Fire Extinguishers, No. 10
- Halogenated Fire Extinguishing Agent Systems, No. 12A

WARNING

ALWAYS DISCONNECT POWER BEFORE OPENING COVERS, DOORS, ENCLOSURES, GATES, PANELS OR SHIELDS. ALWAYS USE GROUNDING STICKS AND SHORT OUT HIGH VOLTAGE POINTS BEFORE SERVICING. NEVER MAKE INTERNAL ADJUSTMENTS, PERFORM MAINTENANCE OR SERVICE WHEN ALONE OR WHEN FATIGUED.

Do not remove, short-circuit or tamper with interlock switches on access covers, doors, enclosures, gates, panels or shields. Keep away from live circuits, know your equipment and don't take chances.

WARNING

IN CASE OF EMERGENCY ENSURE THAT POWER HAS BEEN DISCONNECTED.

Treatment of Electrical Shock

1. If victim is not responsive follow the A-B-Cs of basic life support.

PLACE VICTIM FLAT ON HIS BACK ON A HARD SURFACE

(A) AIRWAY

IF UNCONSCIOUS,
OPEN AIRWAY

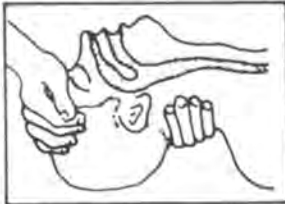

LIFT UP NECK
PUSH FOREHEAD BACK
CLEAR OUT MOUTH IF NECESSARY
OBSERVE FOR BREATHING

(B) BREATHING

IF NOT BREATHING,
BEGIN ARTIFICIAL
BREATHING



TILT HEAD
PINCH NOSTRILS
MAKE AIRTIGHT SEAL

4 QUICK FULL BREATHS

REMEMBER MOUTH TO MOUTH RESUSCITATION
MUST BE COMMENCED AS SOON AS POSSIBLE

CHECK CAROTID PULSE



IF PULSE ABSENT,
BEGIN ARTIFICIAL
CIRCULATION

(C) CIRCULATION

DEPRESS STERNUM 1 1/2" TO 2"

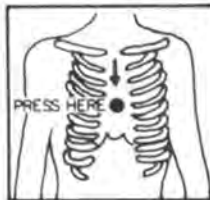

APPROX. 80 SEC. { ONE RESCUER
15 COMPRESSIONS
2 QUICK BREATHS

APPROX. 60 SEC. { TWO RESCUERS
5 COMPRESSIONS
1 BREATH



NOTE: DO NOT INTERRUPT RHYTHM OF COMPRESSIONS
WHEN SECOND PERSON IS GIVING BREATH

Call for medical assistance as soon as possible.

2. If victim is responsive.

- a. keep them warm
- b. keep them as quiet as possible
- c. loosen their clothing
(a reclining position is recommended)

FIRST-AID

Personnel engaged in the installation, operation, maintenance or servicing of this equipment are urged to become familiar with first-aid theory and practices. The following information is not intended to be complete first-aid procedures, it is brief and is only to be used as a reference. It is the duty of all personnel using the equipment to be prepared to give adequate Emergency First Aid and thereby prevent avoidable loss of life.

Treatment of Electrical Burns

1. Extensive burned and broken skin
 - a. Cover area with clean sheet or cloth. (Cleanest available cloth article.)
 - b. Do not break blisters, remove tissue, remove adhered particles of clothing, or apply any salve or ointment.
 - c. Treat victim for shock as required.
 - d. Arrange transportation to a hospital as quickly as possible.
 - e. If arms or legs are affected keep them elevated.

NOTE

If medical help will not be available within an hour and the victim is conscious and not vomiting, give him a weak solution of salt and soda: 1 level teaspoonful of salt and 1/2 level teaspoonful of baking soda to each quart of water (neither hot or cold). Allow victim to sip slowly about 4 ounces (a half of glass) over a period of 15 minutes. Discontinue fluid if vomiting occurs. (Do not give alcohol.)

2. Less severe burns - (1st & 2nd degree)
 - a. Apply cool (not ice cold) compresses using the cleanest available cloth article.
 - b. Do not break blisters, remove tissue, remove adhered particles of clothing, or apply salve or ointment.
 - c. Apply clean dry dressing if necessary.
 - d. Treat victim for shock as required.
 - e. Arrange transportation to a hospital as quickly as possible.
 - f. If arms or legs are affected keep them elevated.

REFERENCE: ILLINOIS HEART ASSOCIATION

AMERICAN RED CROSS STANDARD FIRST AID AND PERSONAL SAFETY MANUAL
(SECOND EDITION)

TABLE OF CONTENTS

<u>Paragraph</u>		<u>Page</u>
SECTION I. GENERAL DESCRIPTION		
1-1.	Equipment Purpose	1
1-3.	Technical Characteristics	1
SECTION II. INSTALLATION		
2-1.	General	1
SECTION III. CONTROLS AND INDICATORS		
3-1.	General	1
SECTION IV. PRINCIPLES OF OPERATION		
4-1.	Circuit Description	11
4-3.	General Description	11
4-4.	Summing Amplifier/Predistortion	11
4-5.	VCO Sub-Module	11
4-6.	RF Amplifier	11
4-7.	Detailed Description	11
4-8.	Audio Preamplifier	11
4-9.	Level Switcher	12
4-10.	Predistortion Network	12
4-13.	VCO Assembly	12
4-14.	Modulation Input	14
4-16.	AFC Input	17
4-17.	Oscillator/Amplifier	17
4-18.	RF Output Circuit	17
4-20.	Power	18
SECTION V. MAINTENANCE		
5-1.	Corrective Maintenance	18
5-3.	Troubleshooting	18
SECTION VI. PARTS LIST		
6-1.	General	34

LIST OF TABLES

<u>Table</u>	<u>Page</u>
1-1. Technical Characteristics	2
3-1. MOD OSC MODULE Controls and Indicators	4
3-2. Control Adjustments	5
5-1. MOD OSC MODULE Fault Isolation Index	20
5-2. MOD OSC MODULE Parts Index	22
6-1. Replaceable Parts List Index	34
6-2. MOD OSC MODULE Front Panel	35
6-3. MOD OSC MODULE Circuit Board	36

LIST OF ILLUSTRATIONS

<u>Figure</u>	<u>Page</u>
3-1. MOD OSC MODULE	3
4-1. MOD OSC MODULE Simplified Block Diagram	13
4-2. MOD OSC MODULE Detailed Block Diagram	15
5-1. MOD OSC MODULE Parts Layout	21
5-2. MOD OSC MODULE Schematic	25
5-3. VCO ASSEMBLY Schematic	27
5-4. No RF Output (AFC/PLL MODULE Lock Indicator Illuminated)	29
5-5. No RF Output (AFC/PLL MODULE Lock Indication Out)	30
5-6. Noise	31
5-7. Distortion	32
5-8. No Modulation	33

SECTION I

GENERAL DESCRIPTION

1-1. EQUIPMENT PURPOSE

1-2. The MOD OSC MODULE contains the voltage controlled oscillator (VCO) assembly which generates the frequency modulated rf carrier from a composite modulating signal input. An rf amplifier chain on the module produces an rf output at 250 milliwatts to drive the RF AMP module and an output at two milliwatts is used as a feedback signal to the AFC/PLL module. The rf output frequency is controlled by a dc voltage obtained from the AFC/PLL module as part of phase locked frequency control. Level switching for different combinations of SCA, stereophonic, and monaural operation is also provided by the module.

1-3. TECHNICAL CHARACTERISTICS

1-4. Table 1-1 lists operating characteristics and parameters of the MS-15 MOD OSC MODULE and VCO assembly.

SECTION II

INSTALLATION

2-1. GENERAL

2-2. Refer to 888-1742-001, MS-15 FM Exciter, Section II, Installation.

SECTION III

CONTROLS AND INDICATORS

3-1. GENERAL

3-2. Figure 3-1 shows the location of each control or indicator associated with the MS-15 MOD OSC MODULE and table 3-1 lists the controls and indicators with a description of each item listed. Control setup adjustments are listed in table 3-2.

Table 1-1. Technical Characteristics

FUNCTION	CHARACTERISTIC
<u>INPUTS</u>	
POWER:	+20 Vdc @ 0.200 amperes
	-20 Vdc @ 0.025 amperes
SIGNAL:	
QUAD COMPOSITE SCA 1/SCA 2 COMPOSITE	1.0 RMS for 100% modulation. 100 millivolts RMS for 10% modulation.
STEREO or MONO COMPOSITE EXTERNAL COMPOSITE	1.0 RMS for 100% modulation. 1.0 RMS for 100% modulation.
CONTROL:	
AFC CONTROL VOLTAGE	+3 Vdc to +12 Vdc, Dependent upon exciter frequency.
SCA 1/2 CONTROL	+6 Vdc with SCA off. -6 Vdc with SCA on.
<u>OUTPUTS</u>	
POWER:	+15 Vdc @ 0.022 amperes
	-15 Vdc @ 0.018 amperes
SIGNAL:	
RF DRIVE	250 milliwatt on-frequency rf to RF AMP module.
PLL FEEDBACK	2.0 milliwatt on-frequency rf sample to AFC/PLL module.
DETECTED RF	3.5 Vdc to dc meter circuit
B-BAND AUDIO	1.0V RMS to ac meter circuit

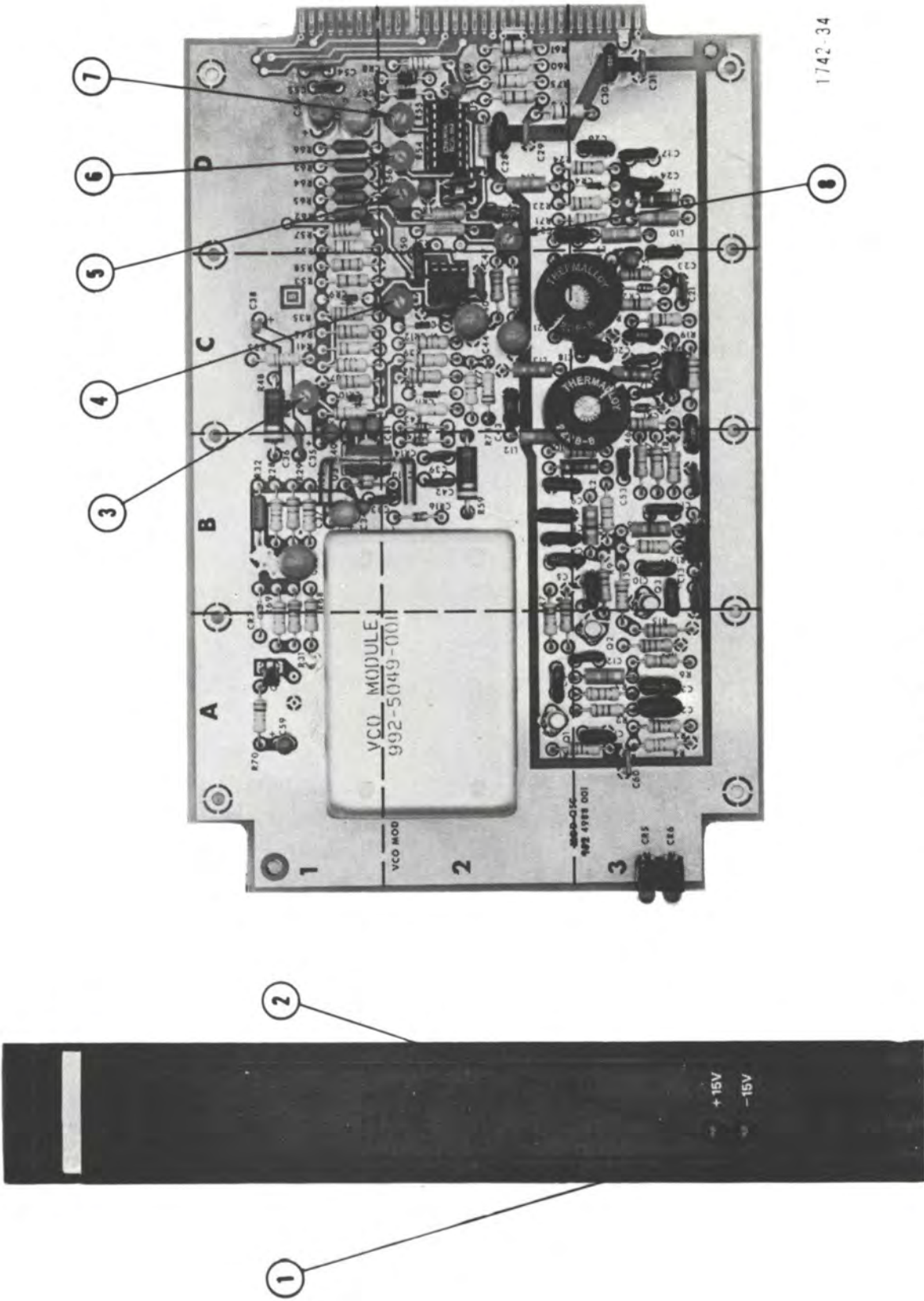

Figure 3-1. MOD OSC MODULE

Table 3-1. MOD OSC MODULE Controls and Indicators

REF.	CONTROL/INDICATOR	FUNCTION
1	-15V Indicator (CR6)	Illuminates to indicate the MOD OSC MODULE -15 volt regulator is operational.
2	+15V Indicator (CR5)	Illuminates to indicate the MOD OSC MODULE +15 volt regulator is operational.
3	VCO GAIN Control (R74)	Adjusts VCO modulation sensitivity.
4	DIST. NULL Control (R67)	Adjusts amount of pre-distortion applied to modulating signal.
5	B-BAND LEVEL Control (R56)	Adjusts total modulation level for correct drive to pre-distortion network.
6	SCA-1 LEVEL SHIFT Control (R54)	Adjusts attenuation of modulating signal to allow SCA-1 injection without overmodulation.
7	SCA-2 LEVEL SHIFT Control (R55)	Adjusts attenuation of modulating signal to allow SCA-2 injection without overmodulation.
8	RF POWER CALIBRATE Control (R72)	Calibrates exciter MULTIMETER MOD OSC module rf power indication.

Table 3-2. Control Adjustments

CONTROL	ADJUSTMENT
<p>B-BAND LEVEL Control (R56)</p>	<ol style="list-style-type: none"> 1. Remove the STEREO ANALOG module from the exciter. 2. Remove the module from the exciter and remove the side cover. 3. Mount the module in the exciter using the extender board provided with the exciter. 4. Depress the OFF switches on each SCA module. The SCA OFF indicators will illuminate. 5. Disconnect the signal from the COMPOSITE INPUT (J4) on the rear of the exciter and apply a 2.83V P-P <u>+1%</u> 400 Hz sinewave into J4. 6. Connect an oscilloscope to monitor pin 6 of U1 for a 4.6V P-P signal. 7. Adjust R56 to obtain a 4.6V P-P <u>+1%</u> indication. 8. Disconnect the oscilloscope, remove the module and extender board, replace the side cover and replace the module in the exciter. Replace the STEREO ANALOG module and reconnect the signal to the COMPOSITE INPUT (J4).
<p>VCO GAIN Control (R74)</p>	<ol style="list-style-type: none"> 1. Remove the STEREO ANALOG module from the exciter. 2. Remove the module. Mount the module in the exciter using the extender board provided with the exciter.

Table 3-2. Control Adjustments (Continued)

CONTROL	ADJUSTMENT
<p>DIST. NULL Control (R67)</p>	<ol style="list-style-type: none"> 3. Connect the exciter rf output to a 50 ohm load through a directional coupler or line sampler. 4. Connect a modulation monitor to the line sampler or the forward port of the directional coupler. 5. Disconnect the signal from the COMPOSITE INPUT (J4) on the rear of the exciter and apply a 2.83V P-P <u>+1%</u> 400 Hz sinewave into J4. 6. Adjust R74 to obtain an indication of 10% modulation. 7. Remove the module and extender board, replace the module in the exciter, and reconnect the exciter output to the load. Replace the STEREO ANALOG module and reconnect the signal to the COMPOSITE INPUT (J4). 1. Remove the STEREO ANALOG module from the exciter. 2. Remove the module from the exciter and remove the side cover. 3. Mount the module in the exciter using the extender board provided with the exciter. 4. Connect the exciter rf output to a 50 ohm load through a directional coupler or line sampler.

Table 3-2. Control Adjustments (Continued)

CONTROL	ADJUSTMENT
	<ol style="list-style-type: none"> <li data-bbox="826 394 1417 485">5. Connect a modulation monitor to the line sampler or the forward port of the directional coupler. <li data-bbox="826 527 1417 680">6. Connect an intermodulation distortion analyzer to the modulation monitor composite output or the audio output with the de-emphasis disabled. <li data-bbox="826 722 1417 875">7. Disconnect the signal from the COMPOSITE INPUT (J4) on the rear of the exciter and apply a 2.83V P-P <u>+1%</u> SMPTE intermodulation test signal into J4. <li data-bbox="826 917 1417 1134">8. Check the voltage at pin 6 of U1 with an oscilloscope for 4.6V P-P <u>+1%</u>. If the voltage is incorrect, the B-BAND LEVEL Control (R55) adjustment procedure must be accomplished before proceeding. <li data-bbox="826 1176 1417 1232">9. Adjust R67 to obtain a minimum intermodulation distortion. <li data-bbox="826 1274 1417 1365">10. Change the signal input to the COMPOSITE INPUT (J4) to a 2.83V P-P <u>+1%</u> 400 Hz sinewave. <li data-bbox="826 1407 1417 1623">11. Check the voltage at pin 6 of U1 with an oscilloscope for 4.6V P-P <u>+1%</u>. If the voltage is incorrect, the B-BAND LEVEL Control (R56) adjustment procedure must be accomplished before proceeding.

Table 3-2. Control Adjustments (Continued)

CONTROL	ADJUSTMENT
<p>SCA-1 LEVEL SHIFT Control (R54)</p> <p>SCA-2 LEVEL SHIFT Control (R55)</p>	<ol style="list-style-type: none"> 12. Check the modulation monitor for 100% total modulation. If the modulation level is not correct, the VCO GAIN Control (R74) adjustment procedure must be accomplished before proceeding. 13. If R56 was adjusted in step 11 or R74 was adjusted in step 12, repeat steps 4 through 12 until R56 and R74 no longer require adjustment. 14. If R56 was adjusted, depress the MODULATION B-BAND switch and adjust the R5 on the ac meter board until the MODULATION meter indicates 100%. 15. Remove the module and extender board, replace the side cover, replace the module in the exciter, and reconnect the exciter output to the load. Replace the STEREO ANALOG module and reconnect the signal to the COMPOSITE INPUT (J4). <ol style="list-style-type: none"> 1. Remove the STEREO ANALOG module from the exciter. 2. Depress the OFF switches on each SCA module. The SCA OFF indicators will illuminate. 3. Remove the module. Mount the module in the exciter using extender board provided with the exciter. 4. Depress the B-BAND MODULATION meter switch.

Table 3-2. Control Adjustments (Continued)

CONTROL	ADJUSTMENT
	<ol style="list-style-type: none"> <li data-bbox="842 394 1433 485">5. Depress the SCA 1 ON switch. The SCA 1 ON indicator will illuminate. <li data-bbox="842 527 1433 653">6. Connect the exciter rf output to a 50 ohm load through a directional coupler or line sampler. <li data-bbox="842 695 1433 785">7. Connect a modulation monitor to the line sampler or the forward port of the directional coupler. <li data-bbox="842 827 1433 917">8. Connect an SCA monitor to the SCA provision on the modulation monitor. <li data-bbox="842 959 1433 1050">9. Adjust the INJ LEV control on the SCA 1 module for the desired amount of SCA 1 injection. <li data-bbox="842 1092 1433 1182">10. Apply a 2.83V P-P +1% 400 Hz sinewave to the COMPOSITE INPUT (J4) on the rear of the exciter. <li data-bbox="842 1224 1433 1314">11. Adjust R54 to obtain an indication of 100% total modulation on the MODULATION meter. <li data-bbox="842 1356 1433 1446">12. Disconnect the test signal applied to the COMPOSITE INPUT (J4) on the rear of the exciter. <li data-bbox="842 1488 1433 1614">13. Repeat steps 9 through 12 until 100% total modulation at the desired SCA injection level is obtained. <li data-bbox="842 1656 1433 1747">14. Repeat steps 1 through 14 for the SCA 2 module, adjusting R55.

Table 3-2. Control Adjustments (Continued)

CONTROL	ADJUSTMENT
<p>R.F. POWER CALIBRATE Control (R72)</p>	<ol style="list-style-type: none"> 15. Remove the module and extender board. Replace the module in the exciter and reconnect the exciter output to the load. Replace the STEREO ANALOG module and reconnect the signal to the COMPOSITE INPUT (J4). 1. Remove the module. Mount the module in the exciter using the extender board provided with the exciter. 2. Depress the MULTIMETER MOD OSC meter switch. 3. Adjust R72 to obtain a 300 milliwatt indication on the MULTIMETER. 4. Remove the module and extender board and replace the module in the exciter.

SECTION IV
PRINCIPLES OF OPERATION

4-1. CIRCUIT DESCRIPTION

4-2. The MOD OSC MODULE contains a VCO sub-module which generates a frequency modulated rf carrier (see figure 4-1). The rf center frequency is controlled by a dc correction voltage from the AFC/PLL module as part of a phase locked loop. The carrier deviation is controlled by a modulation voltage produced from individual audio inputs. The module rf output is amplified into two outputs of approximately 250 milliwatts and two milliwatts to drive the RF AMP and AFC/PLL modules, respectively.

4-3. GENERAL DESCRIPTION

4-4. SUMMING AMPLIFIER/PREDISTORTION. Individual composite inputs from each option are summed at the input to the module summing amplifier. An RC input network ensures each signal is summed in the correct proportion. A true summing node at virtual ground eliminates interaction between inputs. An SCA control input and a level switcher arrangement controls the summing amplifier gain to allow for various combination of SCA channels and maintain a constant peak modulating signal level. The slight distortion in VCO modulation characteristic to other designs is substantially reduced in the MS-15. The modulating signal is applied to a predistortion network which adds a small portion of distortion to cancel distortion generated by the VCO.

4-5. VCO SUB-MODULE. The voltage controlled oscillator accepts the pre-distorted audio input and a dc frequency correction voltage from the AFC/PLL module and generates the modulated rf carrier. A varactor tuned MOSFET oscillator drives a MOSFET buffer stage for isolation.

4-6. RF AMPLIFIER. The rf amplifier produces two outputs from the 300 millivolt RMS output of the VCO sub-module. One output of 250 milliwatts drives the RF AMP module and the second output of two milliwatts is applied to the AFC/PLL module as the phase locked loop feedback path to control the rf carrier center frequency.

4-7. DETAILED DESCRIPTION

4-8. AUDIO PREAMPLIFIER. Five composite signals are input to the modulated oscillator. The quadraphonic composite and stereophonic or monaural composite inputs are dc coupled and the SCA 1, SCA 2, and the external composite inputs are ac coupled to amplifier U1. All modulation applied to amplifier U1 is summed to a total modulation (B-BAND) signal. The amplifier gain is established by feedback through resistor R51 and the B-BAND LEVEL control (R56) which provides an adjustment to obtain a precise signal level. The B-Band audio is output from the audio preamplifier at the level of 4.6V P-P to the ac meter module which provides an indication of the modulating signal level (see figure 4-2).

4-9. LEVEL SWITCHER. Whenever an SCA subcarrier is enabled, a positive six volt dc level closes a corresponding MOD OSC MODULE CMOS switch pair in U2. This shunts feedback resistor R51 and reduces the gain of the audio preamplifier. The SCA-1 LEVEL SHIFT control (R54) and the SCA-2 LEVEL SHIFT control (R55) provide an adjustment to calibrate the gain reduction to the SCA channel injection level. As a result, 100% peak modulation is maintained for all combinations of SCA, monaural, and stereophonic modes. A negative six volt dc level input from each SCA module to the respective CMOS switch holds the CMOS switches open when the SCA subcarrier is off. To prevent level switcher operation when an SCA module is removed from the exciter, an internal negative six volt source is connected to each control input to U2.

4-10. PREDISTORTION NETWORK. The predistortion network cancels the slight distortion caused by nonlinearity of the VCO to produce lower audio distortion, high stereo separation, and improved SCA performance. The predistortion is accomplished by a diode/resistor network which accepts total modulation from amplifier U1 and acts as a level dependent voltage divider across the DIST. NULL control (R67) and the VCO GAIN control (R74). The signal level at the output of R67 is 4.6V P-P and may be checked at test point TP-2.

4-11. The cathodes of diodes CR10 and CR11 are biased at +0.57 volts and the cathodes of diodes CR9 and CR12 are biased at +1.42 volts. When amplifier U1 outputs zero volts (no signal), diodes CR9 and CR10 will conduct and diodes CR11 and CR12 are turned off. As the modulating voltage swings in a positive direction, CR9 and CR10 conduct less and eventually turn off. As the modulating voltage swings in a negative direction, CR11 and CR12 turn on when the modulating voltage exceeds the bias threshold on each diode.

4-12. Whenever any diode is turned on, the modulation signal from amplifier U1 is shunted to ground through resistors in the predistortion network. This effect slightly stretches the positive portion of the modulating signal in the negative direction to cancel the effect of the VCO assembly slight modulation nonlinearity. The DIST. NULL control (R67) provides an adjustment to control the amount of predistortion and the VCO GAIN control (R74) provides an output level adjustment.

4-13. VCO ASSEMBLY. The voltage controlled oscillator comprises a varactor diode tuned Hartley oscillator using MOSFETS in submodule. In the event of VCO failure, repairs to the VCO assembly may be made by cutting out the defective component and installing a replacement.

4-14. Modulation Input. Predistorted modulation is applied through the VCO GAIN control (R74) and coupled through capacitor C37 to the VCO input. The modulation is applied to a back-to-back configuration of varactor diodes in the tank circuit of oscillator Q1.

4-15. As the time constant of coupling capacitor C37 is many times the frequency control phase locked loop lockup time, the capacitor must be quickly charged when power is applied to ensure a stable locked condition.

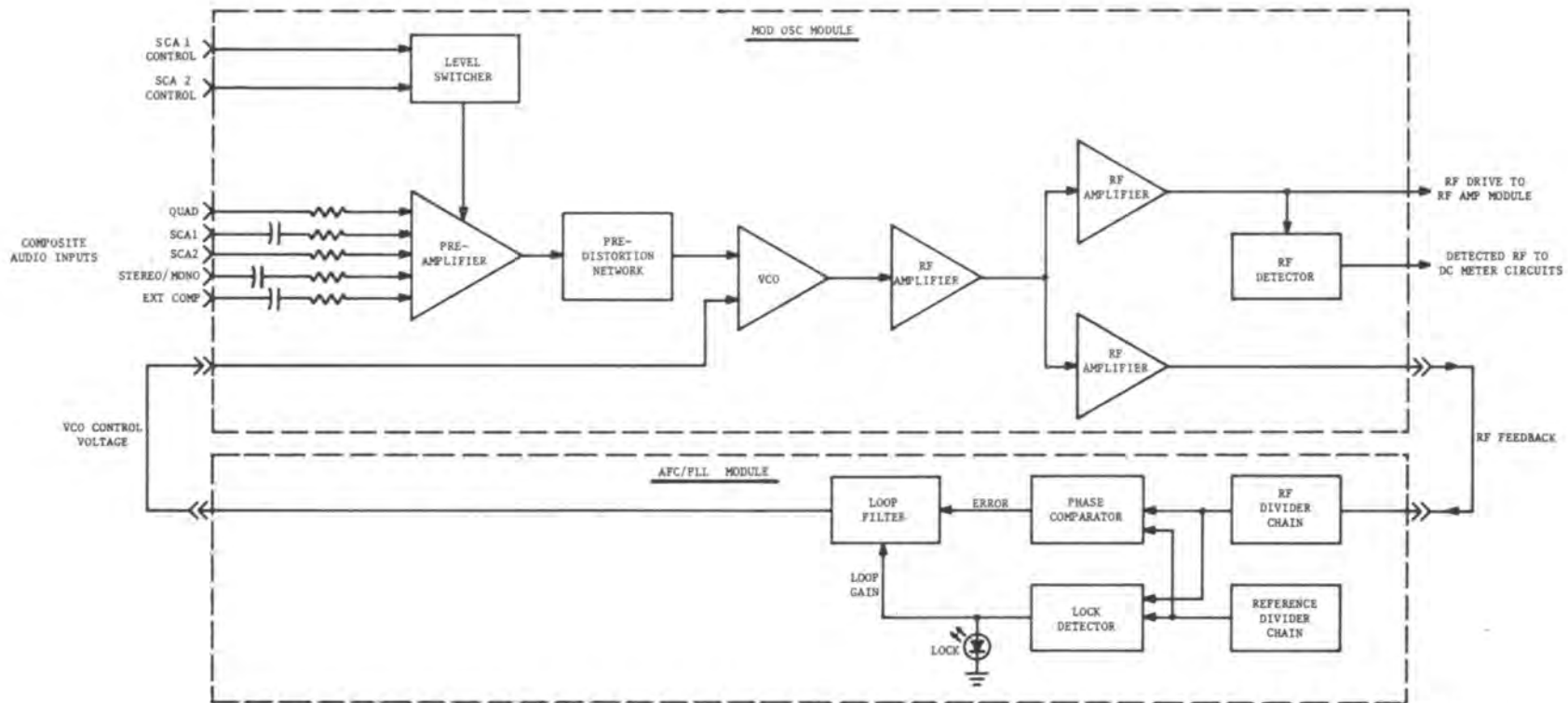

1742-52

Figure 4-1. MOD OSC MODULE Simplified Block Diagram

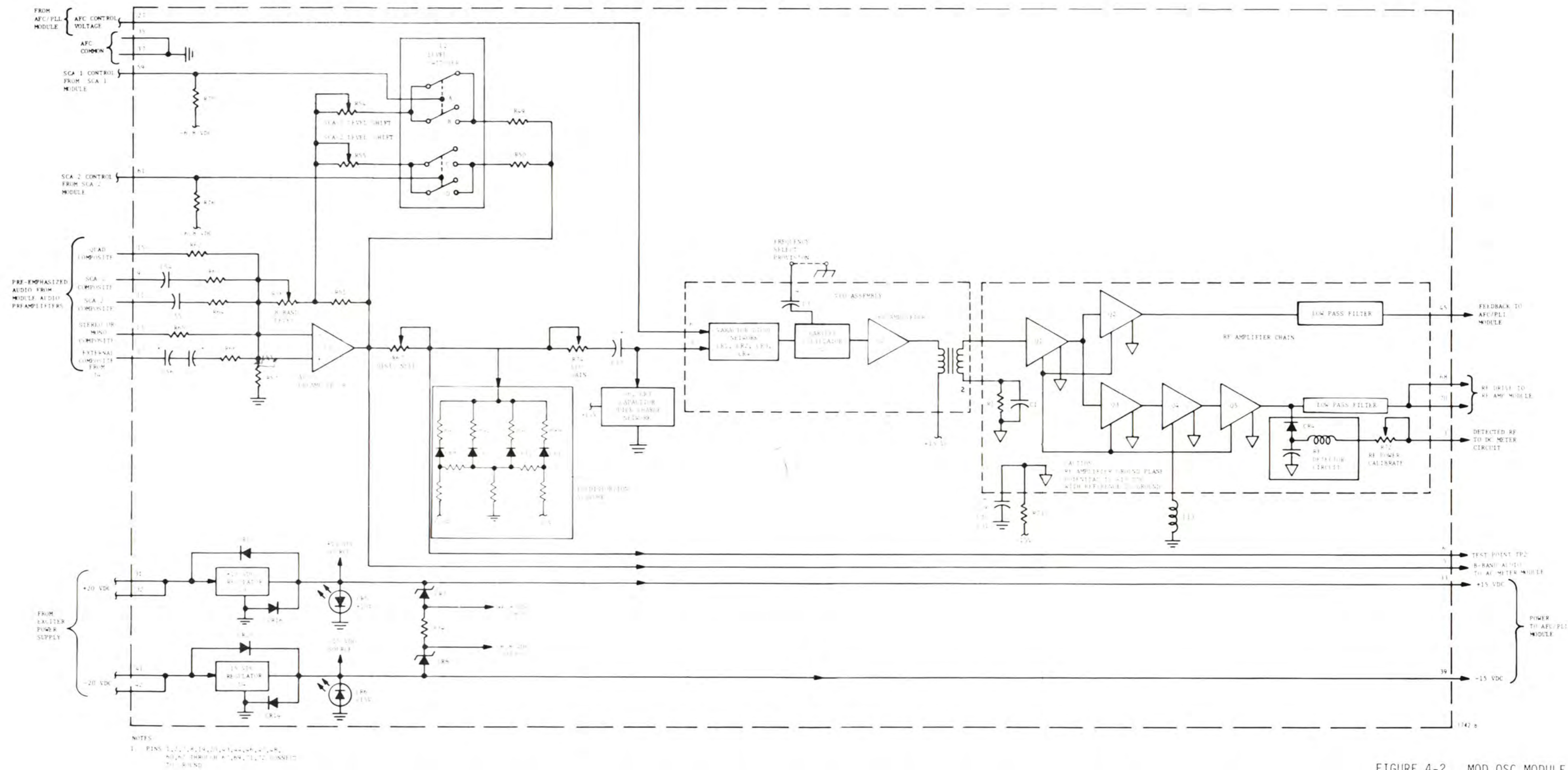

FIGURE 4-2. MOD OSC MODULE DETAILED BLOCK DIAGRAM

The capacitor is charged by a network consisting of Q6 and associated components which charges the capacitor close to the steady state value and decouples itself from the active signal path to present a high impedance input to the varactor diode network. When power is applied, Q6 is turned ON by C59 and C70. C37 is charged through Q6 and a resistive voltage divider. When C49 becomes charged Q6 turns off and C37 continues to charge at a slow rate from the positive source through R31.

4-16. AFC Input. The VCO assembly frequency output is determined by the AFC voltage input from the AFC/PLL module, a positive going potential applied to the VCO assembly increases the oscillator frequency. If the VCO frequency is higher than the internal reference in the AFC/PLL module, a negative going potential applied to the VCO assembly decreases the oscillator frequency. A steady dc potential on the AFC line indicates the VCO frequency and the internal reference frequency in the AFC/PLL module agree. The AFC voltage is applied to a back-to-back configuration of varactor diodes to control oscillator Q1.

4-17. Oscillator/Amplifier. The frequency control voltage and predistorted modulation are combined by the varactor diode network and applied to a common drain Hartley MOSFET oscillator (Q1). The oscillator is connected in a triode configuration with both gates tied together. Capacitor C3 adjusts the bias voltage on the varactors for a region of reduced sensitivity to noise voltage. The AFC will lock within a range of 3-12v, but a nominal value of 5-7v is selected for optimum FM S/N consideration. A MOSFET amplifier follows the oscillator as a buffer stage which outputs the carrier signal. A transformer provides isolation for the following amplifier stages.

4-18. RF OUTPUT CIRCUIT. The rf amplifier is powered by the -15 volt supply and operates on an isolated ground plane. The rf ground plane must not be grounded as this will short the -15 volt dc supply potential. Two rf outputs from the module are provided. One output provides a feedback path for the frequency control phased locked loop circuit in the AFC/PLL module. The second output provides drive to the RF AMP module.

4-19. The rf input to the amplifier chain is inductively coupled by transformer T1 in the VCO to common base amplifier Q1. Separate outputs from Q1 drive the AFC/PLL module input circuit and the succeeding amplifier stages in the MOD OSC MODULE. This provides isolation between the rf amplifier drive and the AFC/PLL module frequency dividers which tend to generate switching products and cause mutual interference. One output from Q1 drives a common emitter amplifier Q2 which outputs two milliwatts of rf through low-pass filter to the AFC/PLL module divide by 16 counter. The second output from Q1 drives a common emitter amplifier Q3 which in turn drives the two successive class B amplifiers (Q4 and Q5). The output of Q5 is applied to a Chebishev impedance matching low-pass filter (L9, L10, L11 C23, and C24) which attenuates harmonics and provides a 50 ohm impedance output from Q5. The output of 250 milliwatts is applied by microstrip transmission line to drive the RF AMP module. The RF AMP module drive is sampled by an rf detector and fed to the dc meter circuit which provides an indication of the rf output level. The RF POWER CALIBRATE control (R72) allows calibration of the meter indication.

4-20. POWER. Inputs of positive and negative regulated 20 Vdc are re-regulated by U3 and U4 into +15 Vdc sources to operate the MOD OSC MODULE. Outputs of positive and negative 15 Vdc are applied to the AFC/PLL module to operate the loop filter circuitry. Diodes CR13, CR14, CR15, and CR16 provide reverse voltage protection for the regulator and module circuitry. Light emitting diodes provide a status indication of the operation of the positive (+15V) and negative (-15V) fifteen volt power supplies. Additionally, positive and negative six Vdc sources are produced from a series circuit consisting of CR7, R34, and CR8 from the +15 volt potentials to control the CMOS level switching circuits.

SECTION V

MAINTENANCE

5-1. CORRECTIVE MAINTENANCE

5-2. The MS-15 FM exciter module maintenance philosophy consists of problem isolation to a specific area or individual component and subsequent isolation and replacement of the defective component.

5-3. TROUBLESHOOTING

5-4. In event of problems, the trouble area must first be isolated to a specific area. Most troubleshooting consists of visual checks. The MODULATION meter, MULTIMETER, fuse F1, circuit breaker CB1, and the indicators on each module should be used to determine in which area the malfunction exists. All module power supplies are equipped with LEDs which indicate the module power supply status. A single dark LED would indicate a problem associated with an individual module monolithic voltage regulator. A consistent pattern of dark LEDs however, would indicate an exciter dc distribution bus fault.

5-5. Once the trouble is isolated to a specific area, refer to the theory section of this manual for circuit discussion to aid in problem resolution. Table 5-1 lists typical trouble symptoms pertaining to the individual module operation with references to fault isolation diagrams listing probable causes and corrective actions. A corrective action given for a trouble symptom is not necessarily the only answer to a problem. It only tends to lead the repairman into the area that may be causing the trouble. An extender board (HARRIS PN 992 4989 001) is provided with the exciter to assist in troubleshooting. In event parts are required, refer to Section VI, Parts List. The following information is contained in this section as an aid to maintenance:

<u>REFERENCE</u>	<u>TITLE</u>	<u>NUMBER</u>
Figure 5-1	MOD OSC MODULE Parts Layout	--- ---- ---
Table 5-2	MOD OSC MODULE Parts Index	--- ---- ---
Figure 5-2	MOD OSC MODULE Waveforms	852 8406 001
Figure 5-3	MOD OSC MODULE Schematic	829 2599 001

Table 5-1. MOD OSC Module Fault Isolation Index

SYMPTOM	DEFECT/REFERENCE
NO RF OUTPUT (AFC/PLL module LOCK indicator illuminated).	Figure 5-4
NO RF OUTPUT (AFC/PLL module LOCK indicator out).	Figure 5-5
NOISE	Figure 5-6
DISTORTION	Figure 5-7
NO MODULATION	Figure 5-8

Table 5-2. MOD OSC MODULE Parts Index (Continued)

SYMBOL	LOCATION	SYMBOL	LOCATION	SYMBOL	LOCATION	SYMBOL	LOCATION	SYMBOL	LOCATION
R1	A3	R29	B1	R57	D1	U1	C2		
R2	A3	R30	B1	R58	C1	U2	D2		
R3	A3	R31	A1	R59	B2	U3	B1		
R4	A3	R32	B1	R60	D2	U4	B1		
R5	A3	R33	C1	R61	D2				
R6	A3	R34	D2	R62	D1				
R7	B2	R35	C1	R63	D1				
R8	B2	R36	C1	R64	D1				
R9	B3	R37	C1	R65	D1				
R10	B3	R38	C2	R66	D1				
R11	B3	R39	C2	R67	C2				
R12	B3	R40	C2	R68	B1				
R13	B3	R41	C1	R69	B1				
R14	A3	R41	C1	R70	A1				
R15	A3	R43	C2	R71	D2				
R16	B3	R44	C2	R72	D2				
R17	B3	R45	C1	R73	C2				
R18	B3	R45	B3	R74	C1				
R19	C3	R47	C2	R75	D2				
R20	C3	R48	C1	R76	D2				
R21	C2	R49	D2						
R22	C3	R50	D2						
R23	D2	R51	D2						
R24	D3	R52	D1						
R25	C3	R53	C1						
R26	D2	R54	D2						
R27	C2	R55	D2						
R28	B1	R56	D2						

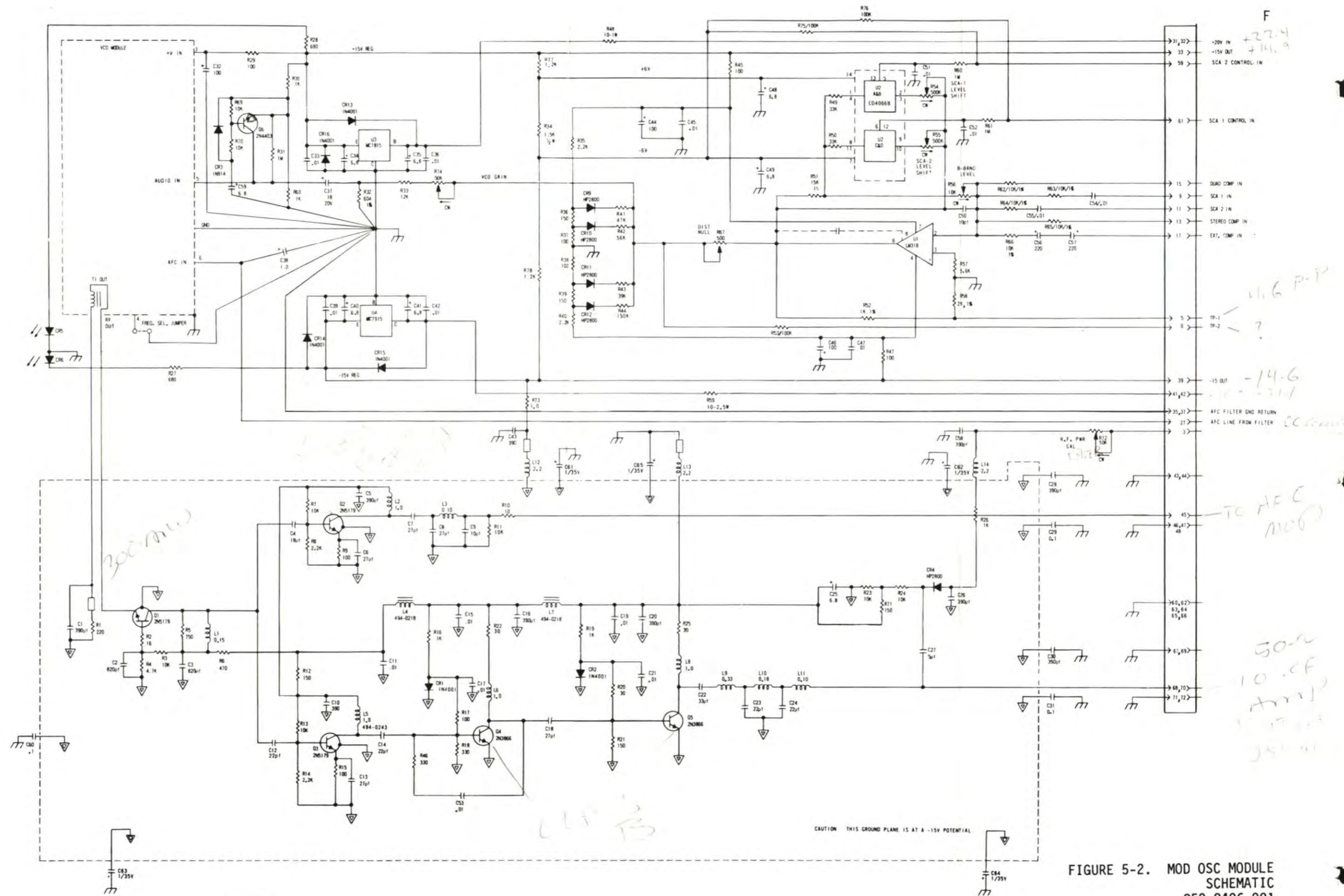

4 ALL INDUCTORS IN UH
 3 ALL CAPACITANCE IN UF
 2 ALL RESISTANCE IN OHMS
 1 ALL RESISTORS 1/2W 5%
 UNLESS OTHERWISE NOTED
 NOTES

If You Didn't Get This From My Site,
 Then It Was Stolen From...
www.SteamPoweredRadio.Com

FIGURE 5-2. MOD OSC MODULE SCHEMATIC 852 8406 001

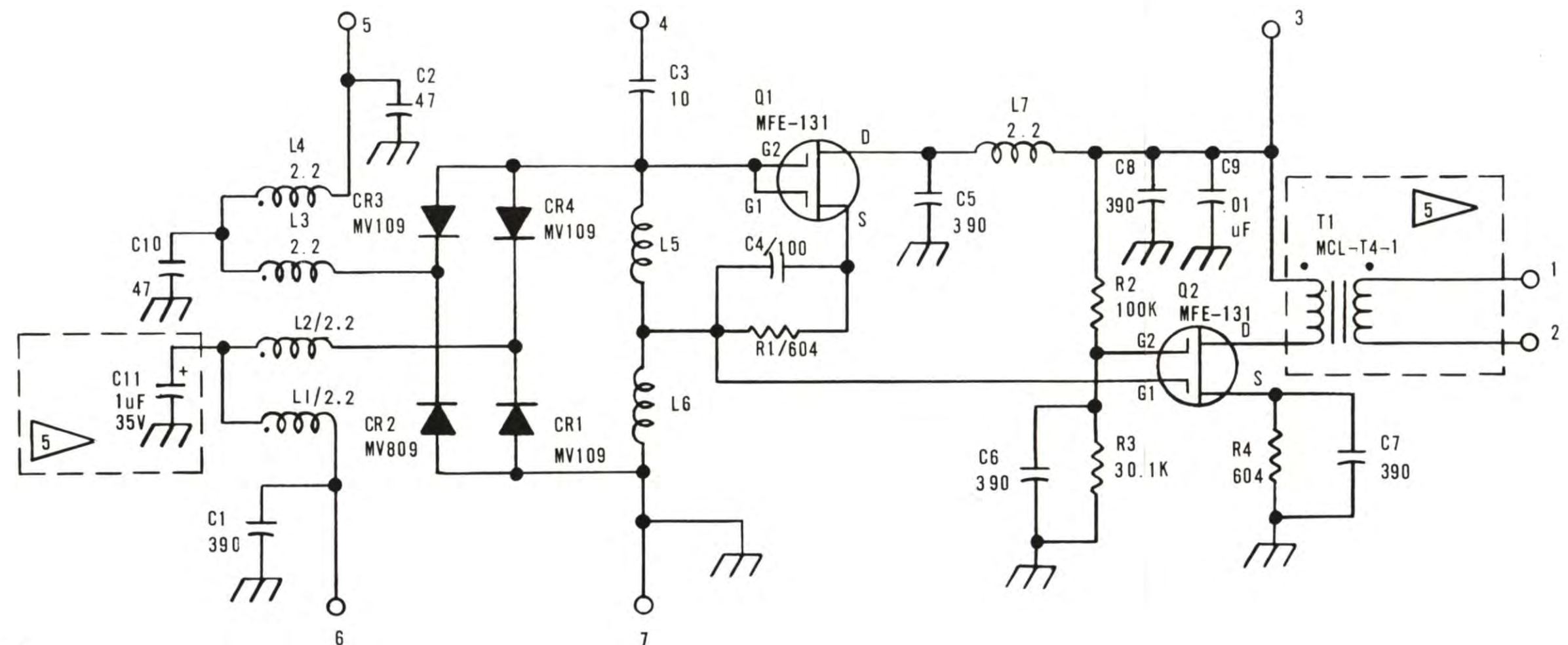

- 5  POTTED AREA
- 4. ALL INDUCTANCE IN μ H
 - 3. ALL CAPACITANCE IN μ F
 - 2. ALL RESISTANCE IN OHMS
 - 1. ALL RESISTORS ARE $\frac{1}{4}$ WATT 1% UNLESS OTHERWISE NOTED:

FIGURE 5-3. VCO ASSEMBLY SCHEMATIC
829 2599 001



1742-104

Figure 5-4. No RF Output (AFC/PLL Module Lock Indicator Illuminated)

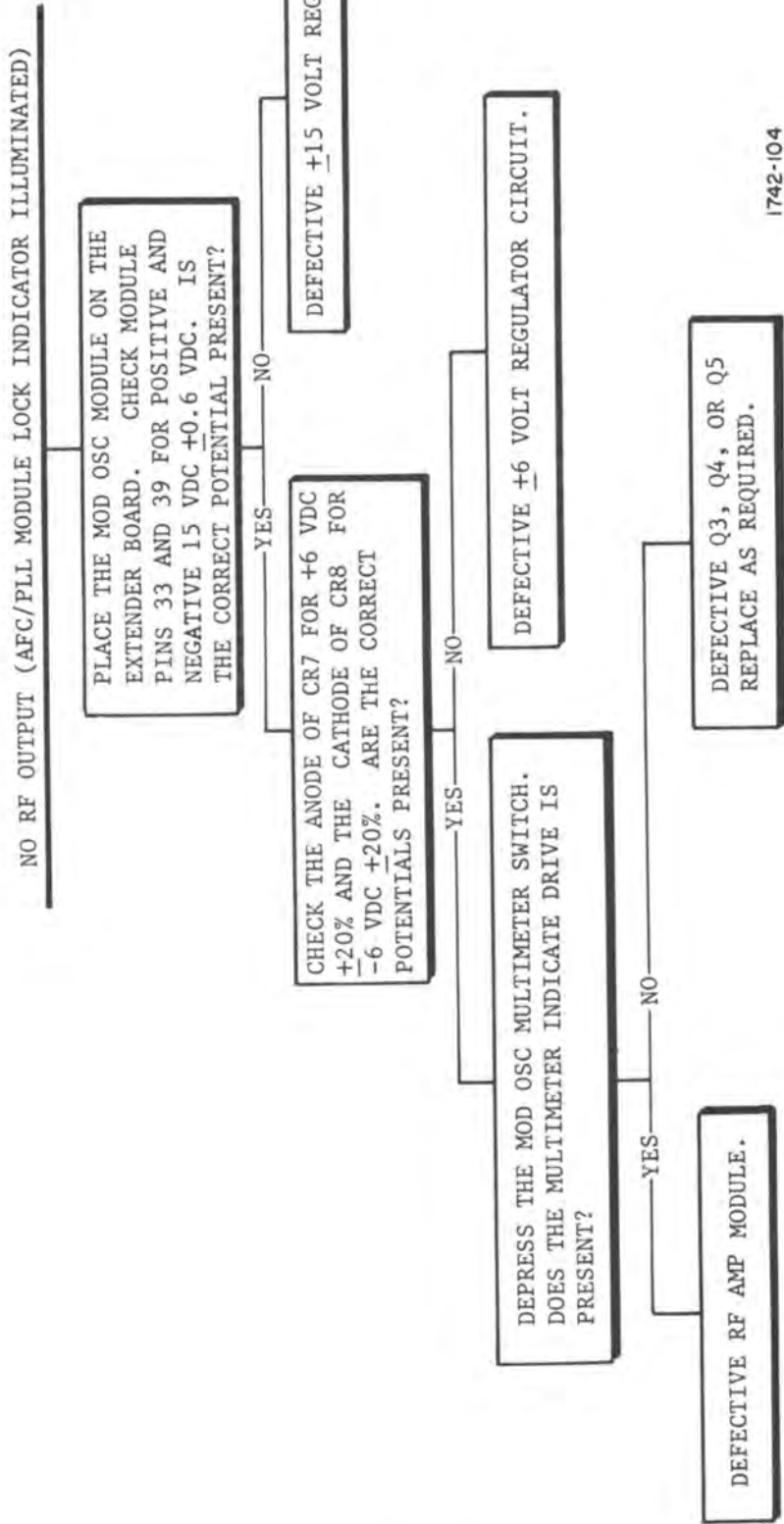
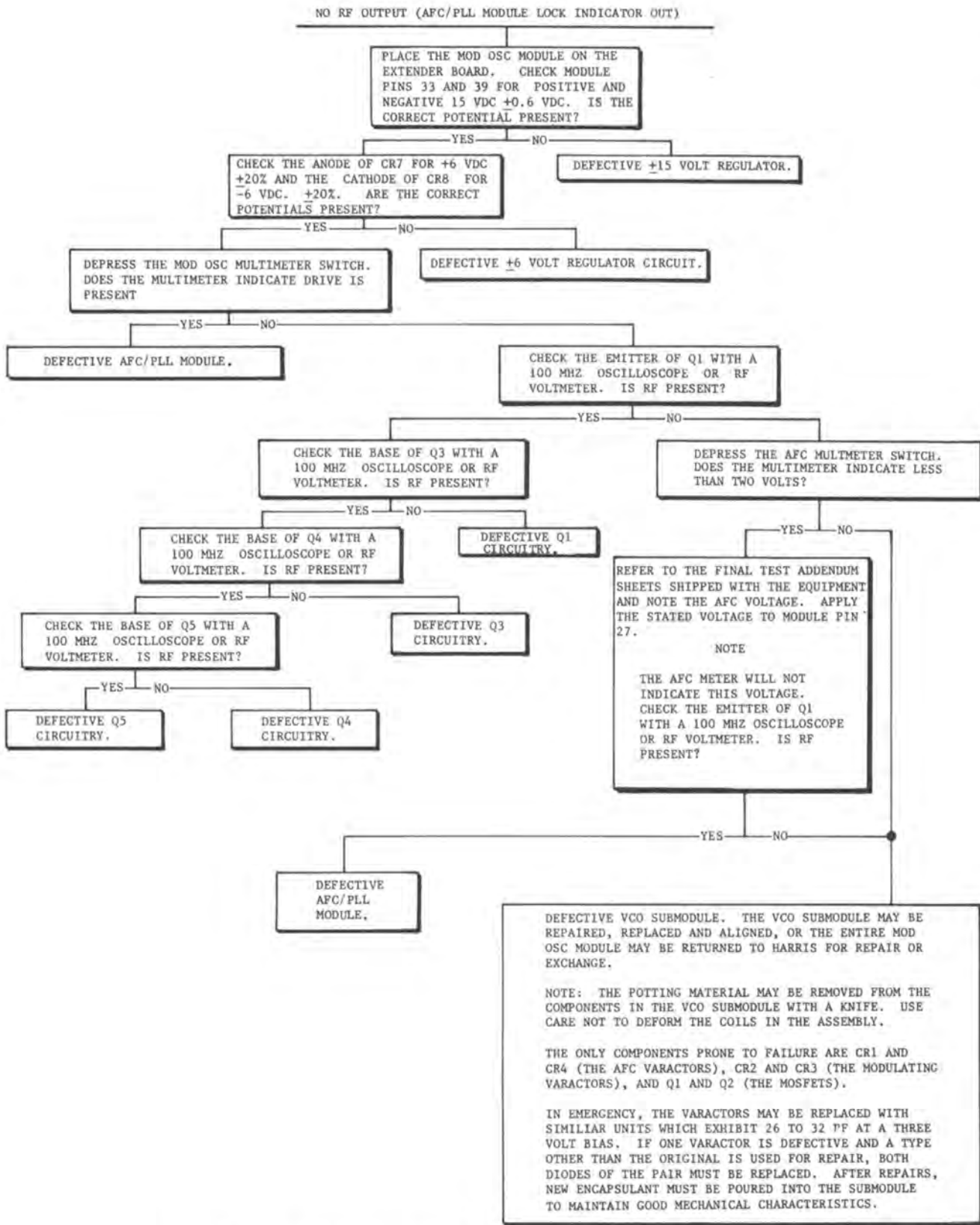

Figure 5-5. No RF Output (AFC/PLL Module Lock Indication Out)

1742-102

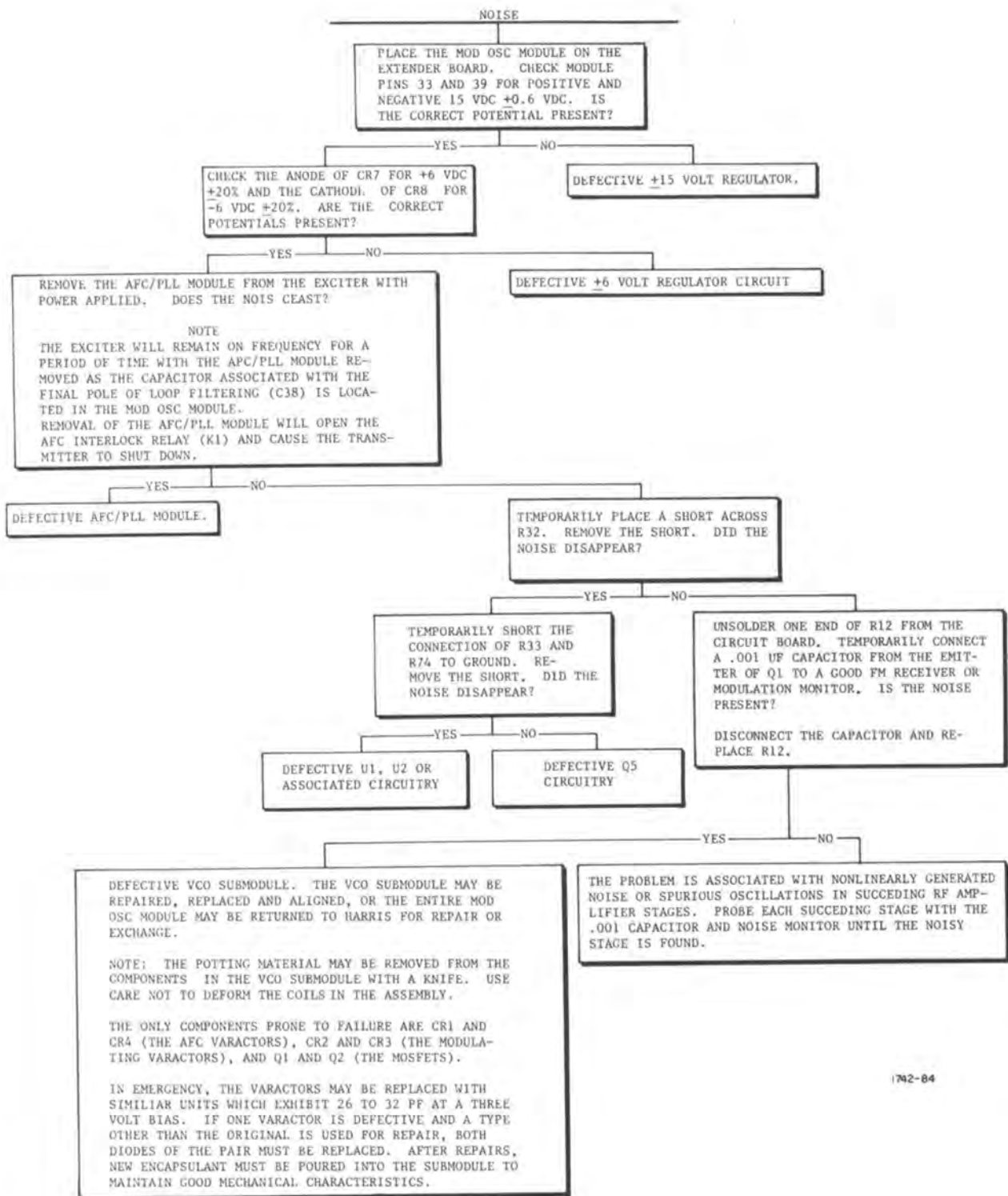
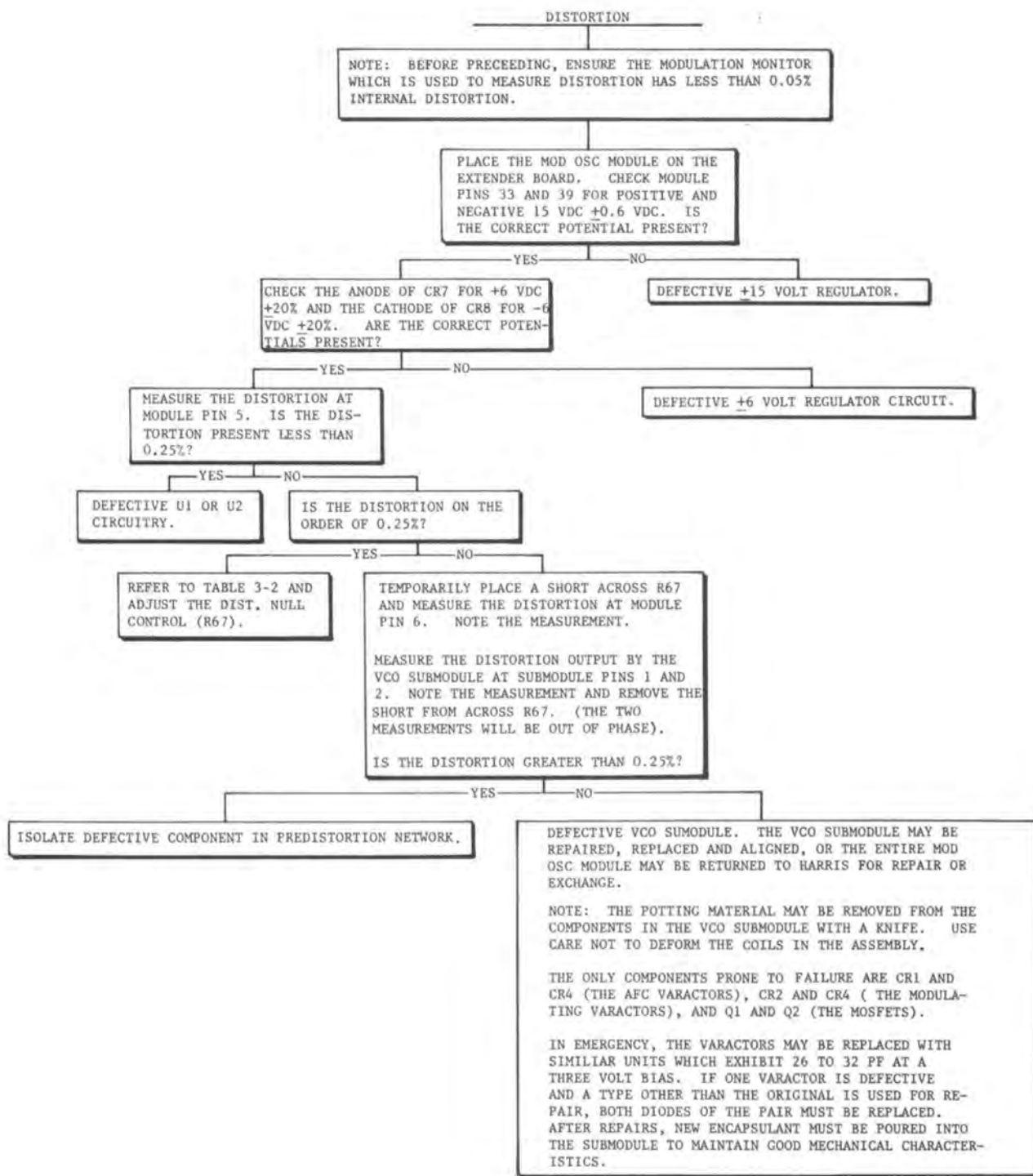
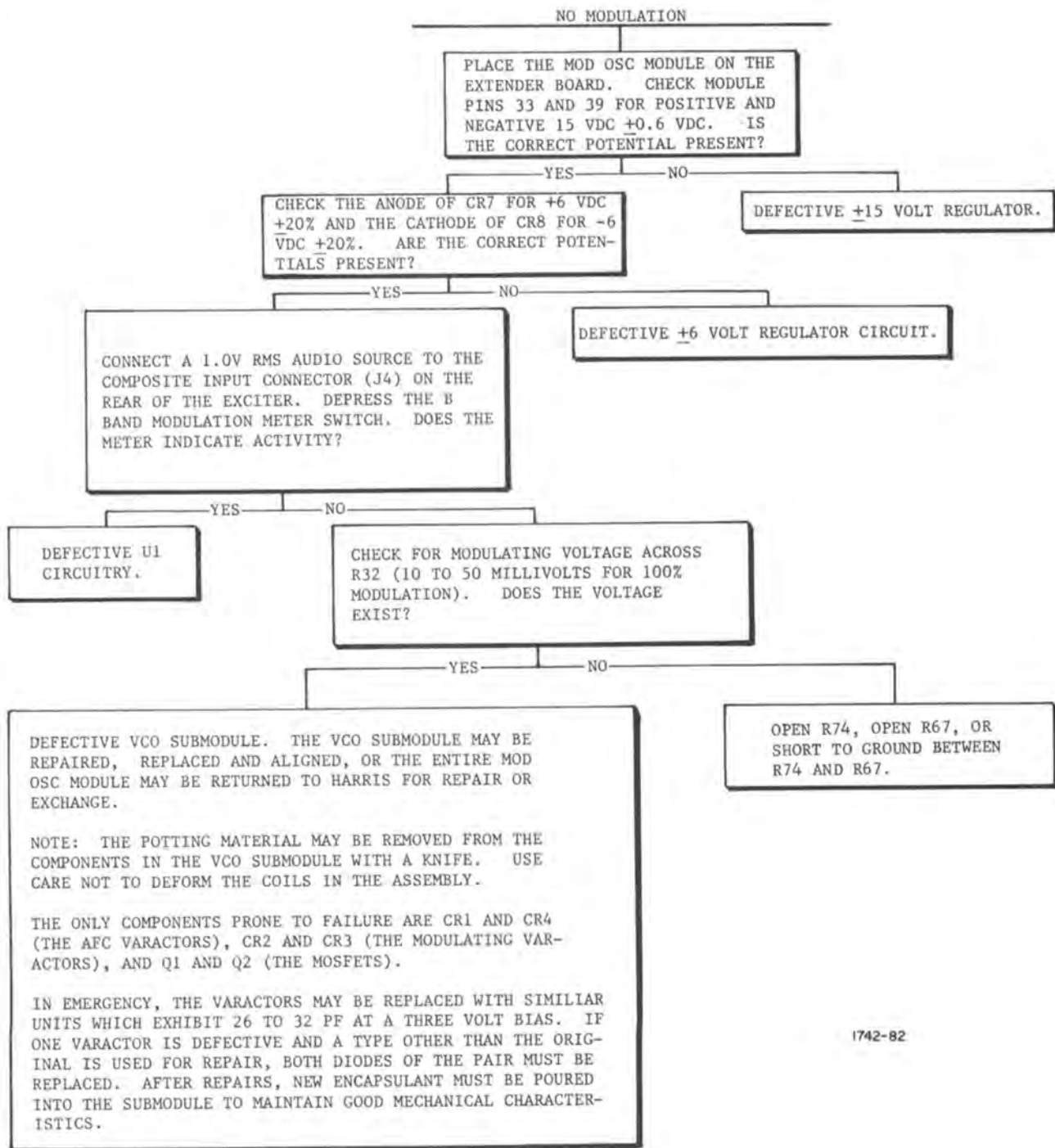

Figure 5-6. Noise



1742-83

Figure 5-7. Distortion



1742-82

Figure 5-8. No Modulation

SECTION VI

PARTS LIST

6-1. GENERAL

6-2. Refer to table 6-1 for replaceable parts which are required for proper maintenance of the MS-15 MOD OSC MODULE and VCO assembly. Tables entries are indexed by component reference designator.

Table 6-1. Replaceable Parts List Index

TABLE NO.	UNIT NOMENCLATURE	PART NO.	PAGE
6-2	MOD OSC MODULE Front Panel	992 4987 001	6-31
6-3	MOD OSC MODULE Circuit Board	992 4988 001	6-32
6-4	VCO Assembly	992 5049 001	6-39
6-5	VCO Assembly Circuit Board	992 5048 001	6-40

Table 6-2. MOD OSC MODULE Front Panel - 992 4987 001

REF. SYMBOL	HARRIS PART NO.	DESCRIPTION	QTY.
-----	992 4988 001	MOD OSC MODULE Circuit Board (Refer to table 6-3)	1

Table 6-3. MOD OSC MODULE Circuit Board - 992 4988 001

REF. SYMBOL	HARRIS PART NO.	DESCRIPTION	QTY.
C1	500 0833 000	Capacitor, 390 pF, 500V, Mica	1
C2,C3	500 0842 000	Capacitor, 820 pF, 300V, Mica	2
C4	500 0807 000	Capacitor, 18 pF, 500V, Mica	1
C5	500 0833 000	Capacitor, 390 pF, 500v, Mica	1
C6,C7,C8	500 0811 000	Capacitor, 27 pF, 500V, Mica	3
C9	500 0804 000	Capacitor, 10 pF, 500V, Mica	1
C10	500 0833 000	Capacitor, 390 pF, 500V, Mica	1
C11	516 0375 000	Capacitor, 0.01 uF, 50V	1
C12	500 0809 000	Capacitor, 22 pF, 500V, Mica	1
C13	500 0811 000	Capacitor, 27 pF, 500V, Mica	1
C14	500 0809 000	Capacitor, 22 pF, 500V	1
C15	516 0375 000	Capacitor, 0.01 uF, 50V	1
C16	500 0833 000	Capacitor, 390 pF, 500V, Mica	1
C17	516 0375 000	Capacitor, 0.01 uF, 50V	1
C18	500 0811 000	Capacitor, 27 pF, 500V, Mica	1
C19	516 0375 000	Capacitor, 0.01 uF, 50V	1
C20	500 0833 000	Capacitor, 390 pF, 500V, Mica	1
C21	515 0375 000	Capacitor, 0.01 uF, 50V	1
C22	516 0453 000	Capacitor, 0.1 uF, 100V, 20%	1
C23,C24	500 0809 000	Capacitor, 22 pF, 500V	2
C25	526 0049 000	Capacitor, 6.8 uF, 35V, 20%	1
C26	500 0833 000	Capacitor, 390 pF, 500V, Mica	1

Table 6-3. MOD OSC MODULE Circuit Board - 992 4988 001 (Continued)

REF. SYMBOL	HARRIS PART NO.	DESCRIPTION	QTY.
C27	500 0803 000	Capacitor, 5 pF, 500V, Mica	1
C28	500 0833 000	Capacitor, 390 pF, 500V, Mica	1
C29	516 0453 000	Capacitor, 0.1 uF, 100V, 20%	1
C30	500 0833 000	Capacitor, 390 pF, 500V, Mica	1
C31	516 0453 000	Capacitor, 0.1 uF, 100V, 20%	1
C32	526 0057 000	Capacitor, 100 uF, 20V, 20%	1
C33	516 0375 000	Capacitor, 0.01 uF, 50V	1
C34,C35	526 0049 000	Capacitor, 6.8 uF, 35V, 20%	2
C36	516 0375 000	Capacitor, 0.01 uF, 50V	1
C37	526 0352 000	Capacitor, 18 uF, 35V, 10%	1
C38	526 0340 000	Capacitor, 1 uF, 35V, 10%	1
C39	516 0375 000	Capacitor, 0.01 uF, 50V	1
C40,C41	526 0049 000	Capacitor, 6.8 uF, 35V, 20%	2
C42	516 0375 000	Capacitor, 0.01 uF, 50V	1
C43	500 0833 000	Capacitor, 390 pF, 500V, Mica	1
C44	526 0057 000	Capacitor, 100 uF, 20V, 20%	1
C45	516 0375 000	Capacitor, 0.01 uF, 50V	1
C46	526 0057 000	Capacitor, 100 uF, 20V, 20%	1
C47	516 0375 000	Capacitor, 0.01 uF, 50V	1
C48,C49	526 0049 000	Capacitor, 6.8 uF, 35V, 20%	2
C50	500 0804 000	Capacitor, 10 pF, 500V, Mica	1
C51 thru C55	516 0375 000	Capacitor, 0.01 uF, 50V	5

Table 6-3. MOD OSC MODULE Circuit Board - 992 4988 001 (Continued)

REF. SYMBOL	HARRIS PART NO.	DESCRIPTION	QTY.
C56,C57	526 0047 000	Capacitor, 220 uF, 10V, 20%	1
C58	500 0833 000	Capacitor, 390 pF, 500V, Mica	1
C59	526 0049 000	Capacitor, 6.8 uF, 35V, 20%	1
C60	516 0453 000	Capacitor, 0.1 uF, 100v, 20%	1
C61 thru C65	526 0050 000	Capacitor, 1 uF, 35V, 20%	5
CR1,CR2	384 0431 000	Rectifier, 1N4001	2
CR3	386 0091 000	Diode, Silicon, 1N914	1
CR4	384 0321 00	Diode, Hot Carrier	1
CR5,CR6	382 0661 000	LED, Green	2
CR7,CR8	386 0091 000	Diode, Silicon, 1N4738	1
CR9 thru CR12	384 0321 000	Diode, Hot Carrier	4
CR13 thru CR16	384 0431 000	Diode, 1N4001	4
L1	494 0374 000	Choke, RF, 0.15 uH	1
L2	394 0384 000	Choke, RF, 1.00 uH	1
L3	404 0372 000	Choke, RF, 0.10 uH	1
L4	404 0218 000	Choke, Wide Band	1
L5,L6	494 0384 000	Choke, RF, 1.00 uH	2
L7	494 0218 00	Choke, Wide Band	1
L8	404 0384 000	Choke, RF, 1.00 uH	1
L9	494 0378 000	Choke, RF, 0.33 uH	1
L10	494 0375 000	Choke, RF, 0.18 uH	1
L11	494 0372 000	Choke, RF, 0.10 uH	1

Table 6-3. MOD OSC MODULE Circuit Board - 992 4988 001 (Continued)

REF. SYMBOL	HARRIS PART NO.	DESCRIPTION	QTY.
L12,L13,L14	494 0388 000	Choke, RF, 2.20 uH	3
Q1,Q2,Q3	380 0536 000	Transistor, 2N5179	3
Q4,Q5	380 0116 000	Transistor, 2N3866	2
Q6	380 0126 000	Transistor, 2N4403	1
R1	540 1118 000	Resistor, 220 ohm, 1/2W, 5%	1
R2	540 1174 000	Resistor, 16 ohm, 1/2W, 5%	1
R3	540 1111 000	Resistor, 10k ohm, 1/2W, 5%	1
R4	540 1114 000	Resistor, 4700 ohm, 1/2W, 5%	1
R5	540 1178 000	Resistor, 750 ohm, 1/2W, 5%	1
R6	540 1115 000	Resistor, 470 ohm, 1/2W, 5%	1
R7	540 1111 000	Resistor, 10k ohm, 1/2W, 5%	1
R8	540 1182 000	Resistor, 2200 ohm, 1/2W, 5%	1
R9	540 1102 000	Resistor, 100 ohm, 1/2W, 5%	1
R10	540 1151 000	Resistor, 10 ohm, 1/2W, 5%	1
R11	540 1111 000	Resistor, 10k ohm, 1/2W, 5%	1
R12	540 1117 000	Resistor, 150 ohm, 1/2W, 5%	1
R13	540 1111 000	Resistor, 10k ohm, 1/2W, 5%	1
R14	540 1182 000	Resistor, 2200 ohm, 1/2W, 5%	1
R15	540 1102 000	Resistor, 100 ohm, 1/2W, 5%	1
R16	540 1116 000	Resistor, 1000 ohm, 1/2W, 5%	1
R17	540 1102 000	Resistor, 100 ohm, 1/2W, 5%	1
R18	540 1216 000	Resistor, 330 ohm, 1/2W, 5%	1

Table 6-3. MOD OSC MODULE Circuit Board - 992 4988 001 (Continued)

REF. SYMBOL	HARRIS PART NO.	DESCRIPTION	QTY.
R19	540 1116 000	Resistor, 1000 ohm, 1/2W, 5%	1
R20	540 1223 000	Resistor, 30 ohm, 1/2W, 5%	1
R21	540 1117 000	Resistor, 150 ohm, 1/2W, 5%	1
R22	540 1223 000	Resistor, 30 ohm, 1/2W, 5%	1
R23,R24	540 1111 000	Resistor, 10k ohm, 1/2W, 5%	2
R25	540 1223 000	Resistor, 30 ohm, 1/2W, 5%	1
R26	540 1116 000	Resistor, 1000 ohm, 1/2W, 5%	1
R27,R28	540 1181 000	Resistor, 680 ohm, 1/2W, 5%	2
R29	540 1102 000	Resistor, 100 ohm, 1/2W, 5%	1
R30	540 1116 000	Resistor, 1000 ohm, 1/2W, 5%	1
R31	540 1162 000	Resistor, 1 Megohm, 1/2W, 5%	1
R32	548 0869 000	Resistor, 604 ohm, 1/4W, 1%	1
R33	540 1171 000	Resistor, 12k ohm, 1/2W, 1%	1
R34	540 1129 000	Resistor, 1500 ohm, 1/2W, 5%	1
R35	540 1182 000	Resistor, 2200 ohm, 1/2W, 5%	1
R36	540 1117 000	Resistor, 150 ohm, 1/2W, 5%	1
R37,R38	540 1102 000	Resistor, 100 ohm, 1/2W, 5%	2
R39	540 1117 000	Resistor, 150 ohm, 1/2W, 5%	1
R40	540 1182 000	Resistor, 2200 ohm, 1/2W, 5%	1
R41	540 1212 000	Resistor, 220k ohm, 1/2W, 5%	1
R42	540 1222 000	Resistor, 62k ohm, 1/2W, 5%	1
R43	540 1185 000	Resistor, 39k ohm, 1/2W, 5%	1

Table 6-3. MOD OSC MODULE Circuit Board - 992 4988 001 (Continued)

REF. SYMBOL	HARRIS PART NO.	DESCRIPTION	QTY.
R44	540 1159 000	Resistor, 100k ohm, 1/2W, 5%	1
R45	540 1102 000	Resistor, 100 ohm, 1/2W, 5%	1
R46	540 1216 000	Resistor, 330 ohm, 1/2W, 5%	1
R47	540 1102 000	Resistor, 100 ohm, 1/2W, 5%	1
R48	540 0284 000	Resistor, 10 ohm, 1W, 5%	1
R49,R50	540 1109 000	Resistor, 33k ohm, 1/2W, 5%	2
R51	548 0340 000	Resistor, 15k ohm, 1/4W, 1%	1
R52	540 1116 000	Resistor, 1000 ohm, 1/2W, 5%	1
R53	540 1159 000	Resistor, 100k ohm, 1/2W, 5%	1
R54,R55	540 0936 000	Potentiometer, 500k ohm, 1/2W	2
R56	550 0922 000	Potentiometer, 10k ohm, 1/2W	1
R57	540 1183 000	Resistor, 5600 ohm, 1/2W, 5%	1
R58	540 1138 000	Resistor, 3000 ohm, 1/2W, 5%	1
R59	540 0593 000	Resistor, 10 ohm, 2.5W, 1%	1
R60,R61	540 1159 000	Resistor, 100k ohm, 1/2W, 5%	1
R62 thru R66	548 1361 000	Resistor, 10k ohm, 1/4W, 1%	5
R67	550 0934 000	Potentiometer, 500 ohm, 1/2W, 10%	1
R68	540 1116 000	Resistor, 1000 ohm, 1/2W, 5%	1
R69,R70	540 1111 000	Resistor, 10k ohm, 1/2W, 5%	2
R71	540 1117 000	Resistor, 150 ohm, 1/2W, 5%	1
R72	550 0929 000	Potentiometer, 50k ohm, 1/4W	1
R73	540 1151 000	Resistor, 10 ohm, 1/2W, 5%	1

Table 6-3. MOD OSC MODULE Circuit Board - 992 4988 001 (Continued)

REF. SYMBOL	HARRIS PART NO.	DESCRIPTION	QTY.
R74	550 0929 000	Potentiometer, 50k ohm, 1/4W	1
R75,R76	540 1159 000	Resistor, 100k ohm, 1/2W, 5%	2
U1	382 0472 000	Integrated Circuit, LM318N	1
U2	382 0523 000	Integrated Circuit, MC14066BCP	1
U3	382 0359 000	Integrated Circuit, MC7815CP	1
U4	382 0360 000	Integrated Circuit, MC7915CP	1
XU1	404 0673 000	Socket, IC, 8 Contact	1
XU2	404 0674 000	Socket, IC, 14 Contact	1
	404 0198 000	Transipad, 10020 DAP (Fits Q4 & Q5)	2
	404 0513 000	Heat Sink PA1-1CB	1
	404 0528 000	Heat Sink 2228B	2
	410 0344 000	Insulator, Kapton	2
	843 1891 001	Printed Board	1
	829 3666 001	Insulator	1

Table 6-4. VCO Assembly - 992 5049 001

REF. SYMBOL	HARRIS PART NO.	DESCRIPTION	QTY.
-----	992 5048 001	VCO Assembly Circuit Board (Refer to table 6-5)	1

Table 6-5. VCO Assembly - 992 5048 001

REF. SYMBOL	HARRIS PART NO.	DESCRIPTION	QTY.
C1	500 0833 000	Capacitor, 390 pF, 500V	1
C2	500 0817 000	Capacitor, 47 pF, 500V	1
C3	518 0047 000	Capacitor, Variable, 2.5-11 pF	1
C4	500 0759 000	Capacitor, 100 pF, 500V	1
C5 thru C8	500 0833 000	Capacitor, 390 pF, 500V	4
C9	516 0375 000	Capacitor, .01 uF, 50V	1
C10	500 0817 000	Capacitor, 47 pF, 500V	1
C11	526 0050 000	Capacitor, 1 uF, 35V	1
C12,C13	500 0833 000	Capacitor, 1 uF, 35V	2
CR3,CR4	528 0030 000	Diode, Varactor	2
L1 thru L4	404 0388 000	Socket, Tube	4
L5	829 2303 002	Inductor	1
L6	829 2303 001	Inductor	1
L7	494 0388 000	Choke, RF, 2.20 uH	1
Q1,Q2	380 0570 000	Transistor, 40673	2
R1	548 0869 000	Resistor, 604 ohm, 1/W, 1%	1
R2	548 0932 000	Resistor, 100k ohm, 1/4W, 1%	1
R3	548 0416 000	Resistor, 30.1k ohm, 1/4W, 1%	1
R4	548 0869 000	Resistor, 604 ohm, 1/4W, 1%	1
T1	478 0392 000	Transformer, RF, Model T4-1	1
	829 2303 001	Printed Circuit Board	1

RF AMP MODULE

TECHNICAL MANUAL

RF AMP MODULE

992 4978 001



HARRIS CORPORATION

Broadcast Products Division

T.M. No. 888-1742-009

Printed: October 1977
Rev. A: February 1978
Rev. B: August 1978
Rev. C: March 1979
Rev. D: April 1980
Rev. E: March 1981
Rev. F: June 1981

WARNING

THE CURRENTS AND VOLTAGES IN THIS EQUIPMENT ARE DANGEROUS. PERSONNEL MUST AT ALL TIMES OBSERVE SAFETY REGULATIONS.

This manual is intended as a general guide for trained and qualified personnel who are aware of the dangers inherent in handling potentially hazardous electrical/electronic circuits. It is not intended to contain a complete statement of all safety precautions which should be observed by personnel in using this or other electronic equipment.

The installation, operation, maintenance and service of this equipment involves risks both to personnel and equipment, and must be performed only by qualified personnel exercising due care. HARRIS CORPORATION shall not be responsible for injury or damage resulting from improper procedures or from the use of improperly trained or inexperienced personnel performing such tasks.

During installation and operation of this equipment, local building codes and fire protection standards must be observed. The following National Fire Protection Association (NFPA) standards are recommended as references:

- Automatic Fire Detectors, No. 72E
- Installation, Maintenance, and Use of Portable Fire Extinguishers, No. 10
- Halogenated Fire Extinguishing Agent Systems, No. 12A

WARNING

ALWAYS DISCONNECT POWER BEFORE OPENING COVERS, DOORS, ENCLOSURES, GATES, PANELS OR SHIELDS. ALWAYS USE GROUNDING STICKS AND SHORT OUT HIGH VOLTAGE POINTS BEFORE SERVICING. NEVER MAKE INTERNAL ADJUSTMENTS, PERFORM MAINTENANCE OR SERVICE WHEN ALONE OR WHEN FATIGUED.

Do not remove, short-circuit or tamper with interlock switches on access covers, doors, enclosures, gates, panels or shields. Keep away from live circuits, know your equipment and don't take chances.

WARNING

IN CASE OF EMERGENCY ENSURE THAT POWER HAS BEEN DISCONNECTED.

Treatment of Electrical Shock

1. If victim is not responsive follow the A-B-Cs of basic life support.

PLACE VICTIM FLAT ON HIS BACK ON A HARD SURFACE

A AIRWAY

IF UNCONSCIOUS,
OPEN AIRWAY

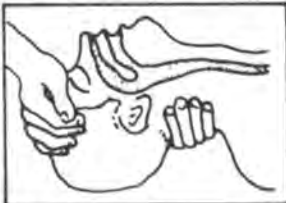

LIFT UP NECK
PUSH FOREHEAD BACK
CLEAR OUT MOUTH IF NECESSARY
OBSERVE FOR BREATHING

B BREATHING

IF NOT BREATHING,
BEGIN ARTIFICIAL
BREATHING



TILT HEAD
PINCH NOSTRILS
MAKE AIRTIGHT SEAL

4 QUICK FULL BREATHS

REMEMBER MOUTH TO MOUTH RESUSCITATION
MUST BE COMMENCED AS SOON AS POSSIBLE

CHECK CAROTID PULSE



IF PULSE ABSENT,
BEGIN ARTIFICIAL
CIRCULATION

C CIRCULATION

DEPRESS STERNUM 1 1/2" TO 2"

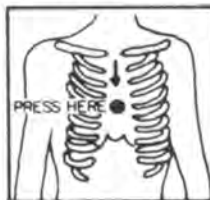

APPROX. { ONE RESCUER
80 SEC. { 15 COMPRESSIONS
2 QUICK BREATHS

APPROX. { TWO RESCUERS
60 SEC. { 5 COMPRESSIONS
1 BREATH



NOTE: DO NOT INTERRUPT RHYTHM OF COMPRESSIONS
WHEN SECOND PERSON IS GIVING BREATH

Call for medical assistance as soon as possible.

2. If victim is responsive.
 - a. keep them warm
 - b. keep them as quiet as possible
 - c. loosen their clothing
(a reclining position is recommended)

FIRST-AID

Personnel engaged in the installation, operation, maintenance or servicing of this equipment are urged to become familiar with first-aid theory and practices. The following information is not intended to be complete first-aid procedures, it is brief and is only to be used as a reference. It is the duty of all personnel using the equipment to be prepared to give adequate Emergency First Aid and thereby prevent avoidable loss of life.

Treatment of Electrical Burns

1. Extensive burned and broken skin
 - a. Cover area with clean sheet or cloth. (Cleanest available cloth article.)
 - b. Do not break blisters, remove tissue, remove adhered particles of clothing, or apply any salve or ointment.
 - c. Treat victim for shock as required.
 - d. Arrange transportation to a hospital as quickly as possible.
 - e. If arms or legs are affected keep them elevated.

NOTE

If medical help will not be available within an hour and the victim is conscious and not vomiting, give him a weak solution of salt and soda: 1 level teaspoonful of salt and 1/2 level teaspoonful of baking soda to each quart of water (neither hot or cold). Allow victim to sip slowly about 4 ounces (a half of glass) over a period of 15 minutes. Discontinue fluid if vomiting occurs. (Do not give alcohol.)

2. Less severe burns - (1st & 2nd degree)
 - a. Apply cool (not ice cold) compresses using the cleanest available cloth article.
 - b. Do not break blisters, remove tissue, remove adhered particles of clothing, or apply salve or ointment.
 - c. Apply clean dry dressing if necessary.
 - d. Treat victim for shock as required.
 - e. Arrange transportation to a hospital as quickly as possible.
 - f. If arms or legs are affected keep them elevated.

REFERENCE: ILLINOIS HEART ASSOCIATION

AMERICAN RED CROSS STANDARD FIRST AID AND PERSONAL SAFETY MANUAL
(SECOND EDITION)

TABLE OF CONTENTS

<u>Paragraph</u>		<u>Page</u>
SECTION I. GENERAL DESCRIPTION		
1-1.	Equipment Purpose	1
1-3.	Technical Characteristics	1
SECTION II. INSTALLATION		
2-1.	General	1
SECTION III. CONTROLS AND INDICATORS		
3-1.	General	1
SECTION IV. PRINCIPLES OF OPERATION		
4-1.	Circuit Description	10
4-2.	RF Circuit	10
4-3.	RF Amplifier	10
4-4.	Output Circuit	10
4-5.	Directional Coupler	10
4-7.	Forward Power Sensor	10
4-8.	Reflected Power Sensor	13
4-9.	VSWR Metering	13
4-10.	Control Circuits	13
4-11.	VSWR Power Limiting	13
4-13.	Amplifier Inhibit	13
4-14.	RF Amplifier AGC	14
4-15.	AGC Operation	14
4-16.	Current Limiting	14
4-17.	Power	14
SECTION V. MAINTENANCE		
5-1.	Corrective Maintenance	15
5-3.	Troubleshooting	15
SECTION VI. PARTS LIST		
6-1.	General	28

LIST OF TABLES

<u>Table</u>	<u>Page</u>
1-1. Technical Characteristics	2
3-1. RF AMP MODULE Controls and Indicators	5
3-2. Controls Adjustments	6
5-1. RF AMP MODULE Fault Isolation Index	17
5-2. RF AMP MODULE Parts Index	19
6-1. RF AMP MODULE Front Panel	29
6-2. RF AMP MODULE Circuit Board	30

LIST OF ILLUSTRATIONS

<u>Figure</u>	<u>Page</u>
3-1. RF AMP MODULE	4
4-1. RF AMP MODULE Block Diagram	11
5-1. RF AMP MODULE Parts Layout	18
5-2. RF AMP MODULE Schematic	21
5-3. No RF Output	23
5-4. Inadequate RF Output	24
5-5. Cannot Reduce Output Power	25
5-6. AM Noise On Output	26
5-7. Fuse F1 Opens	27

SECTION I

GENERAL DESCRIPTION

1-1. EQUIPMENT PURPOSE

1-2. The RF AMP MODULE comprises two class C operated amplifier stages which accept a 250 milliwatt RF input from the MOD OSC module and provide a continuously variable three to fifteen watt RF output. An internal AGC circuit ensures a stable RF output level. Automatic VSWR shutdown, off frequency inhibit control, and power supply current limiting allow automatic module operation. Forward and reflected power sensed by the directional coupler and outputs of amplifier voltage and current provide indications of the module status. RF shutdown, as well as forward and reflected (VSWR) levels are remoteable from provisions on the rear of the exciter.

1-3. TECHNICAL CHARACTERISTICS

1-4. Table 1-1 lists operating characteristics and parameters of the MS-15 RF AMP MODULE.

SECTION II

INSTALLATION

2-1. GENERAL

2-2. Refer to 888-1742-001, MS-15 FM Exciter, Section II, Installation.

SECTION III

CONTROLS AND INDICATORS

3-1. GENERAL

3-2. Figure 3-1 shows the location of each control or indicator associated with the MS-15 RF AMP MODULE and table 3-1 lists the controls and indicators with a description of each item listed. Control setup adjustments are listed in table 3-2.

Table 1-1. Technical Characteristics

FUNCTION	CHARACTERISTIC
<u>INPUTS</u>	
POWER:	Filtered +34 Vdc @ 3.0 amperes maximum. 0 to +24 Vdc, Regulated by external pass transistor.
SIGNAL: RF Drive	87.5 MHz to 108 MHz @ 250 milliwatts.
CONTROL: RF Inhibit External RF Inhibit	Open for Operate Ground for Inhibit Open for Operate Ground for Inhibit
<u>OUTPUTS</u>	
POWER: Regulator Drive	0 to +24 Vdc @ 0.020 amperes.
SIGNAL: RF Carrier	88 MHz to 108 MHz FM @ 3 to 15 watts, adjustable. 50 ohms impedance for full specification performance.
METERING: Amplifier Voltage Amplifier Current	0 to +30 Vdc, full scale 0 to 3.0 amperes, full scale

Table 1-1. Technical Characteristics (Continued)

FUNCTION	CHARACTERISTIC
Forward Power - Local Remote	0 - 4 Vdc into open circuit. 0 - 4 Vdc into open circuit.
Reflected Power - Local Remote	0 - 4 Vdc into open circuit. 0 - 4 Vdc into open circuit.

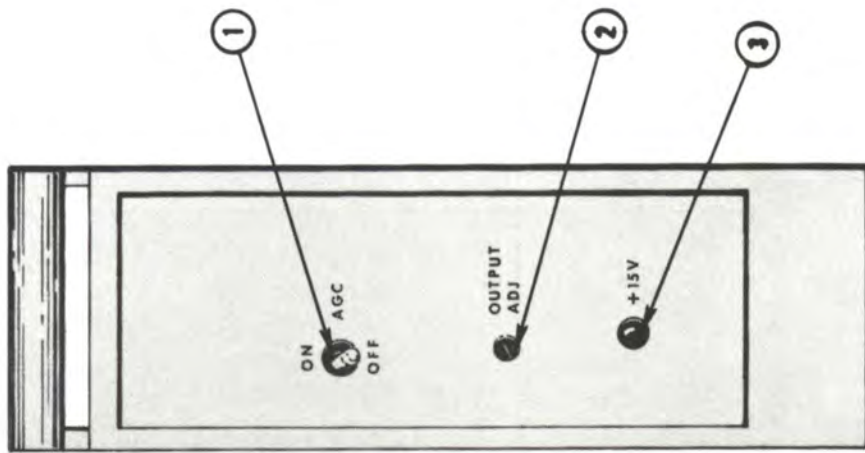

1742-48

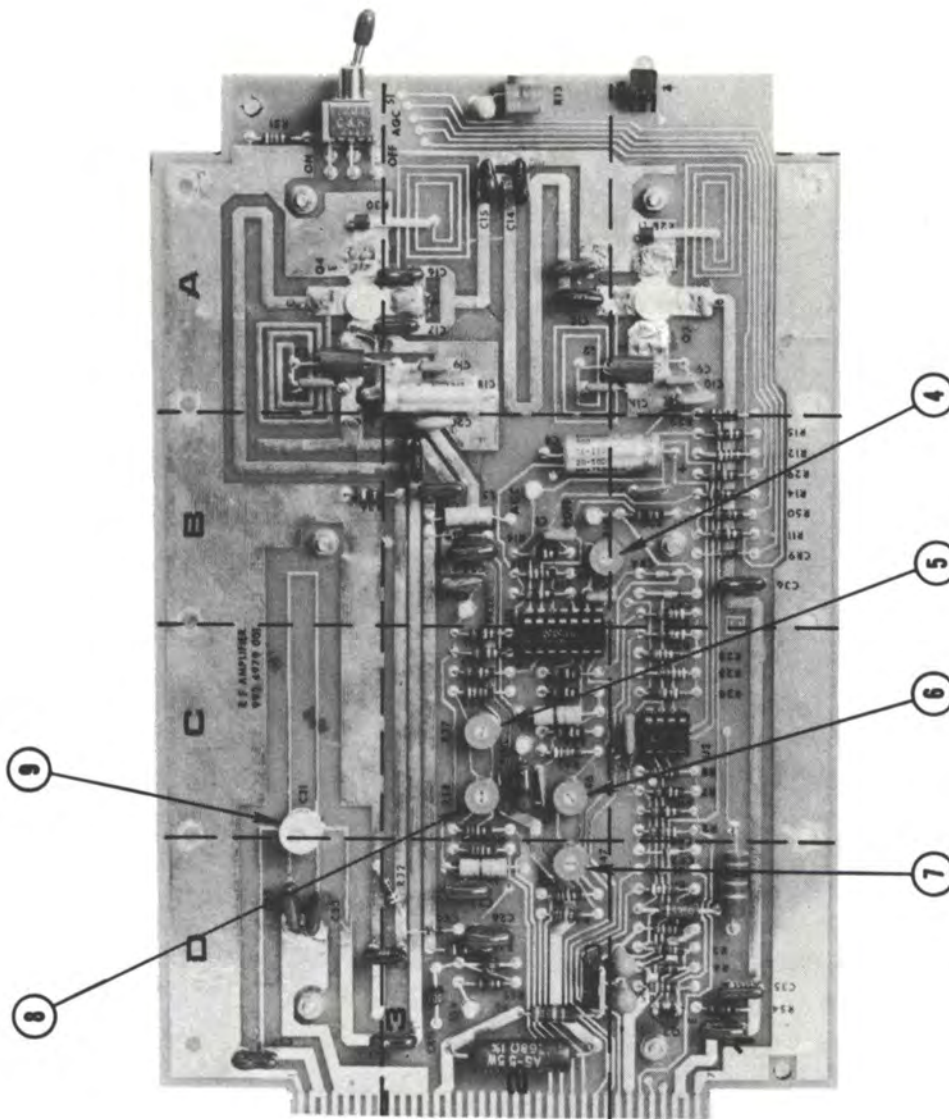

Figure 3-1. RF AMP MODULE

Table 3-1. RF AMP MODULE Controls and Indicators

REF.	CONTROL/INDICATOR	FUNCTION
1	AGC ON/OFF Switch (2A2S1)	Enables the power amplifier automatic output level control.
2	OUTPUT ADJUST Control	Adjusts the power amplifier output level.
3	+15V Indicator (CR5)	Illuminates to indicate the RF AMP MODULE +15 volt regulator is operational.
4	VSWR THRESHOLD Control (R18)	Adjusts the reflected power level at which the module limits rf output.
5	REMOTE POWER REFLECTED LEVEL Control (R37)	Calibrates remote reflected power meter indication.
6	REMOTE POWER FORWARD LEVEL Control (R46)	Calibrates remote forward power meter indication.
7	POWER REF Control (R47)	Calibrates exciter MULTIMETER reflected power indication.
8	POWER FWD Control (R38)	Calibrates exciter MULTIMETER forward power indication.
9	SECOND HARMONIC NOTCH Adjustment (C31)	Adjusts notch filter to second harmonic. Allows use of exciter as a ten watt transmitter - adjustment not required when used as exciter.

Table 3-2. Control Adjustments

CONTROL	ADJUSTMENT
OUTPUT ADJUST Control (R13)	<ol style="list-style-type: none"> 1. Depress the MULTIMETER FWD PWR switch. <p style="text-align: center;">NOTE</p> <p>Due to finite coupler directivity and detector diode forward voltage drop, the range and accuracy of the forward and reflected power indications is limited to <u>+10%</u> full scale.</p> <ol style="list-style-type: none"> 2. If used as an exciter, adjust R19 to obtain the required drive to the transmitter as indicated by the MULTIMETER. 3. If used as a ten watt transmitter, adjust R19 to obtain the licensed power output as indicated by the MULTIMETER.
VSWR THRESHOLD Control (R18)	<ol style="list-style-type: none"> 1. Depress the MULTIMETER FWD PWR Switch. Note the MULTIMETER indication. 2. Depress the MULTIMETER REF PWR Switch. If the MULTIMETER indication is approximately 50% or more of the forward power indication (3.1 VSWR) adjust the exciter load before proceeding. Note the MULTIMETER indication. 3. Remove the module. Mount the module in the exciter using the extender board provided with the exciter.

Table 3-2. Control Adjustments (Continued)

CONTROL	ADJUSTMENT
<p>SECOND HARMONIC NOTCH Adjustment (C31)</p>	<ol style="list-style-type: none"> 4. Disconnect the RF cable from J3 on the rear of the exciter. 5. Adjust R18 fully counterclockwise. 6. Adjust R18 clockwise to increase the MULTIMETER reflected power indication over the indication noted in step 2 as desired. 7. Remove the module and extender board, replace the module in the exciter, and reconnect the RF cable to J3 on the rear of the exciter. <p style="text-align: center;">NOTE</p> <p>This adjustment is only required when using the MS-15 as a ten watt transmitter.</p> <ol style="list-style-type: none"> 1. Connect the exciter RF output to a 50 ohm load through a directional coupler or line sampler. 2. Connect a spectrum analyzer to the line sampler or directional coupler forward port. 3. Remove the module. Mount the module in the exciter using the extender board provided with the exciter. 4. Note the spectrum analyzer display and adjust C31 for minimum amplitude of the second harmonic.

Table 3-2. Control Adjustments (Continued)

CONTROL	ADJUSTMENT
<p>POWER FWD Control (R38)</p> <p>REMOTE POWER FORWARD LEVEL Control (R46)</p> <p>POWER REF Control (R47)</p> <p>REMOTE POWER REFLECTED LEVEL Control (R37)</p>	<p>5. Remove the module and extender board, replace the module in the exciter, and reconnect the exciter output to the load.</p> <p style="text-align: center;">NOTE</p> <p>This procedure affects meter calibration only and should not be adjusted unless the meter circuit is repaired.</p> <p>1. Connect the exciter RF output to a 50 ohm load through an accurately calibrated wattmeter capable of measuring forward and reflected power.</p> <p>2. Remove the module. Mount the module in the exciter using the extender board provided with the exciter.</p> <p>3. Adjust the wattmeter to measure forward power and adjust the OUTPUT ADJ control to obtain a mid-range indication on the external wattmeter.</p> <p>4. Depress the MULTIMETER FWD PWR switch and adjust R38 until the MULTIMETER indication matches the external wattmeter indication.</p> <p>5. If an external forward power meter is used, adjust R46 until the indication matches the external wattmeter indication.</p>

Table 3-2. Control Adjustments (Continued)

CONTROL	ADJUSTMENT
	<ol style="list-style-type: none"> <li data-bbox="836 415 1422 541">6. Adjust the external wattmeter to measure reflected power. Replace the 50 ohm load with a 2:1 to 3:1 mismatch. <li data-bbox="836 579 1422 737">7. Depress the MULTIMETER REF PWR switch and adjust R47 until the MULTIMETER indication matches the external wattmeter indication. <li data-bbox="836 774 1422 900">8. If an external reflected power meter is used, adjust R37 until the indication matches the external wattmeter indication. <li data-bbox="836 938 1422 1064">9. Remove the module and extender board, replace the module in the the exciter, and reconnect the exciter output to the load.

SECTION IV

PRINCIPLES OF OPERATION

4-1. CIRCUIT DESCRIPTION

4-2. RF CIRCUIT

4-3. RF AMPLIFIER. Drive is input to the RF AMP MODULE from the MOD OSC module at a level of 250 milliwatts (see figure 4-1). Chebishev wideband impedance matching networks allow full 88 MHz to 108 MHz coverage with no amplifier tuning. The RF input is matched to the base impedance of Q3 by capacitors C35, C36, and a series section of microstrip. The RF driver (Q3) amplifies the signal to approximately a two watt maximum level. A matching network consisting of capacitors C13 through C17 and the associated series sections of microstrip match the collector impedance of Q3 to the base impedance of the RF final amplifier (Q4) over the entire FM broadcast band. The fifteen watt maximum output is transformed to a 50 ohm impedance by capacitor C22 and the output section of series microstrip. DC blocking is provided by capacitor C23.

4-4. OUTPUT CIRCUIT. The RF is output through a directional coupler and a low-pass filter implemented with microstrip techniques. The shunt leg at the input to the filter consisting of the series combination of a section of microstrip and capacitor C32 traps the third harmonic. In a similar manner, the output shunt leg consisting of the series combination of a section of microstrip and capacitor C33, traps the second harmonic. The series leg consisting of a parallel combination of microstrip and the SECOND HARMONIC NOTCH control (C31) provides additional suppression of the second harmonic. This control should be adjusted as required to reduce the second harmonic to a minimum level when the exciter is used as a low power transmitter. This adjustment is not required when using the unit as an exciter. The remaining series microstrip and shunt capacitor C37 attenuate harmonics above the third harmonic. The RF carrier is output from J3 on the rear of the exciter at an impedance of 50 ohms.

4-5. DIRECTIONAL COUPLER

4-6. The RF AMP MODULE includes a directional coupler produced in printed circuit form with microstrip techniques using the principle that adjacent sections of microstrip transmission line share common inductive and capacitive coupling. Due to basic microstrip principles, perfect directivity cannot be achieved. This limits the "zeroing" of the reflected power directional coupler.

4-7. FORWARD POWER SENSOR. The forward port of the directional coupler is broadbanded over the entire commercial FM broadcast band by capacitor C27 and L5. Resistor R41 terminates diode CR8 which rectifies the RF present at the unterminated end of the sensing line. The voltage is filtered by C28, C30, and L6 and applied to the AGC amplifier (U1D) and to the forward power meter amplifier (U1B). The PINC test point (TP1) provides a convenient

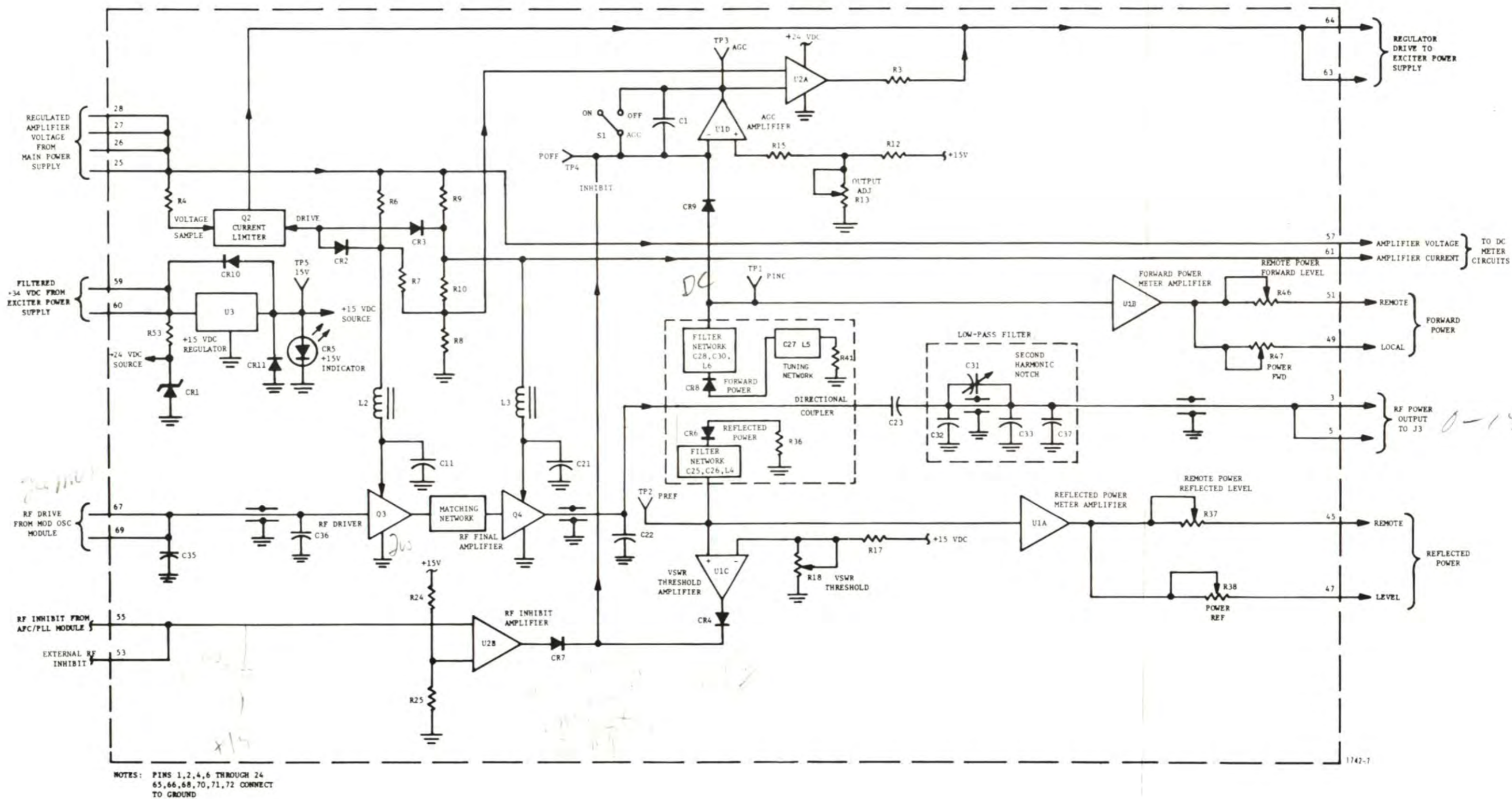

FIGURE 4-1. RF AMP MODULE BLOCK DIAGRAM

location to monitor the potential developed by the forward port of the directional coupler.

4-8. REFLECTED POWER SENSOR. The reflected port of the directional coupler similarly develops a rectified RF voltage through CR6 produced along the sensing line which is terminated by resistor R36. The voltage is filtered by C25, C26, and L4 and applied to the VSWR threshold amplifier (U1C) and the reflected power meter amplifier (U1A). The PREF test point (TP2) provides a convenient location to monitor the potential developed by the reflected port of the directional coupler.

4-9. VSWR METERING. The forward power indication is applied to the forward power meter amplifier (U1B) which isolates the local and remote power meters from the directional coupler. In a similar manner, the reflected power indication is applied to the reflected power meter amplifier (U1B). One output from each meter amplifier is applied to the DC meter circuits to provide a local indication of the forward and reflected power. The local indications are calibrated by the POWER FWD control (R47) and the POWER REF control (R38). Provisions on the rear of the exciter allow both the forward and reflected power indications to be remoted. The REMOTE POWER FORWARD LEVEL control (R37) allows calibration of both potentials to match external metering.

4-10. CONTROL CIRCUITS

4-11. VSWR POWER LIMITING. The VSWR power limiting circuit automatically limits the RF power output to prevent over-dissipation of the RF amplifier devices. It does not totally inhibit RF power output. Under high VSWR conditions, the amplifier could become unstable and the foldback current limiting circuit could create spurious outputs. Thus, the RF AMP MODULE should not be operated into high VSWR conditions for maximum performance. No damage can be expected under short or open load conditions if the factory adjustment of the VSWR THRESHOLD control (R18) is maintained.

4-12. The directional coupler reflected power output is monitored by adjustable threshold amplifier U1C. Whenever the reflected power exceeds the level preset by the VSWR THRESHOLD control (R18), a bias is applied through CR4 to the AGC amplifier (U1D) which limits the voltage applied to the RF amplifier devices and thereby protects the output stages. The POFF test point (TP4) provides a convenient location to monitor the control bias to the AGC amplifier (U1D).

4-13. AMPLIFIER INHIBIT. During power application or whenever a frequency unlocked condition exists between the AFC/PLL module and the MOD OSC module, a ground is automatically applied from the AFC/PLL module to the input of the RF inhibit amplifier (U2B) which inhibits RF output. The ground causes amplifier U2B to output a bias through CR7 to the AGC amplifier (U1D) which removes the voltage applied to the RF amplifier stages. When the AFC/PLL module signals a frequency locked condition, RF output is again enabled. The RF shutdown provision is remoteable from connections on the rear of the exciter. The POFF test point (TP4) provides a convenient location to monitor the control bias to the AGC amplifier (U1D).

4-14. RF AMPLIFIER AGC. RF amplifier output power is controlled by regulating the RF amplifier collector voltage. This allows simplified AGC circuitry and high RF power transistor efficiency at all power levels. As less thermal stress on the RF power transistors will produce more reliable operation, heat generated by the controlling process is dissipated by the DC regulator in the power supply. To ensure adequate heat dissipation, the RF transistors and the DC regulator transistor are mounted on large heat sinks in the direct air flow from the fan.

4-15. AGC Operation. High gain negative AGC feedback determines the supply potential applied to the RF output transistors. A DC voltage proportional to the forward power output is produced by the directional coupler and applied to the inverting input of AGC amplifier U1D. A reference voltage which is adjusted by the OUTPUT ADJ control (R13) is applied to the non-inverting input of the AGC amplifier. If the RF output power decreases beyond the value adjusted by R13, the inverting input of the AGC amplifier will be driven increasingly negative. This causes the output of U1D to increase in a positive direction which in turn drives regulator driver U2A in a positive direction. U2A compares a sample of the RF collector voltage and drives regulator transistor Q1 in the exciter power supply to increase the RF amplifier collector voltage. If the RF output power increases beyond the AGC value, the opposite sequence limits the power applied to the RF amplifier collector circuit. The only DC feedback path for U1D in the AGC mode is through the entire AGC control loop. The AGC circuit is disabled to allow manual control by adding negative feedback directly to the AGC amplifier (U1D) through the AGC ON/OFF switch (S1).

4-16. Current Limiting. RF amplifier collector current through resistors R6 and R9 is monitored by current limiter Q2. If the collector of Q3 exceeds 0.5 amperes or if the collector current of Q4 exceeds two amperes, the AGC control loop action will be overridden by the current limiter stage which prevents any increase in drive to power supply regulator transistor Q1. During normal operation, the current through resistors R6 and R9 cuts off current limiter Q2.

4-17. POWER

4-18. Filtered positive 34 VDC obtained from the exciter power supply enters the module on pins 59 and 60. The potential is regulated into a positive 15 Vdc source by U3 to operate the RF AMP MODULE internal circuitry. Diodes CR10 and CR11 protect the regulator circuit from damage due to shorts and reverse potentials. The +15V indicator provides an indication of the internal power supply status. Additionally a stabilized source of positive 24 Vdc is developed by R53 and CR1 to operate the regulator driver (U2A).

SECTION V
MAINTENANCE

5-1. CORRECTIVE MAINTENANCE

5-2. The MS-15 FM exciter module maintenance philosophy consists of problem isolation to a specific area or individual component and subsequent isolation and replacement of the defective component.

5-3. TROUBLESHOOTING

5-4. In event of problems, the trouble area must first be isolated to a specific area. Most troubleshooting consists of visual checks. The MODULATION meter, MULTIMETER, FUSE F1, circuit breaker CB1, and the indicators on each module should be used to determine in which area the malfunction exists. All module power supplies are equipped with LEDs which indicate the module power supply status. A single dark LED would indicate a problem associated with an individual module monolithic voltage regulator. A consistent pattern of dark LEDs however, would indicate an exciter DC distribution bus fault.

5-5. Once the trouble is isolated to a specific area, refer to the theory section of this manual for circuit discussion to aid in problem resolution. Table 5-1 lists typical trouble symptoms pertaining to the individual module operation with references to fault isolation diagrams listing probable causes and corrective actions. A corrective action given for a trouble symptom is not necessarily the only answer to a problem. It only tends to lead the repairman into the area that may be causing the trouble. An extender board (HARRIS PN 992 4989 001) is provided with the exciter to assist in troubleshooting. In event parts are required, refer to Section VI, Parts List. The following information is contained in this section as an aid to maintenance:

WARNING

LOW VOLTAGES ARE USED THROUGHOUT THE MODULE CIRCUITRY, HOWEVER MAINTENANCE WITH POWER ENERGIZED IS ALWAYS HAZARDOUS AND CAUTION SHOULD BE OBSERVED. THIS IS PARTICULARLY TRUE OF THE RF AMP MODULE WHERE HIGH RF POTENTIALS EXIST AT HIGH IMPEDANCE POINTS. IT IS POSSIBLE TO RECEIVE PAINFUL BUT USUALLY NOT INJURIOUS RF BURNS FROM THE 15 WATT OUTPUT STAGE. COMPONENT OR MODULE REPLACEMENT WITH POWER ON IS NOT RECOMMENDED.

REFERENCE

TITLE

NUMBER

Figure 5-1

RF AMP MODULE Parts Layout

Table 5-2

RF AMP MODULE Parts Index

Figure 5-2

RF AMP MODULE Schematic

852 8396 001

Table 5-1. RF AMP MODULE Fault Isolation Index

SYMPTOM	DEFECT/REFERENCE
NO RF OUTPUT	Figure 5-3.
INADEQUATE RF OUTPUT	Figure 5-4.
CANNOT REDUCE OUTPUT POWER	Figure 5-5.
AM NOISE ON OUTPUT	Figure 5-6.
FUSE F1 OPENS	Figure 5-7.

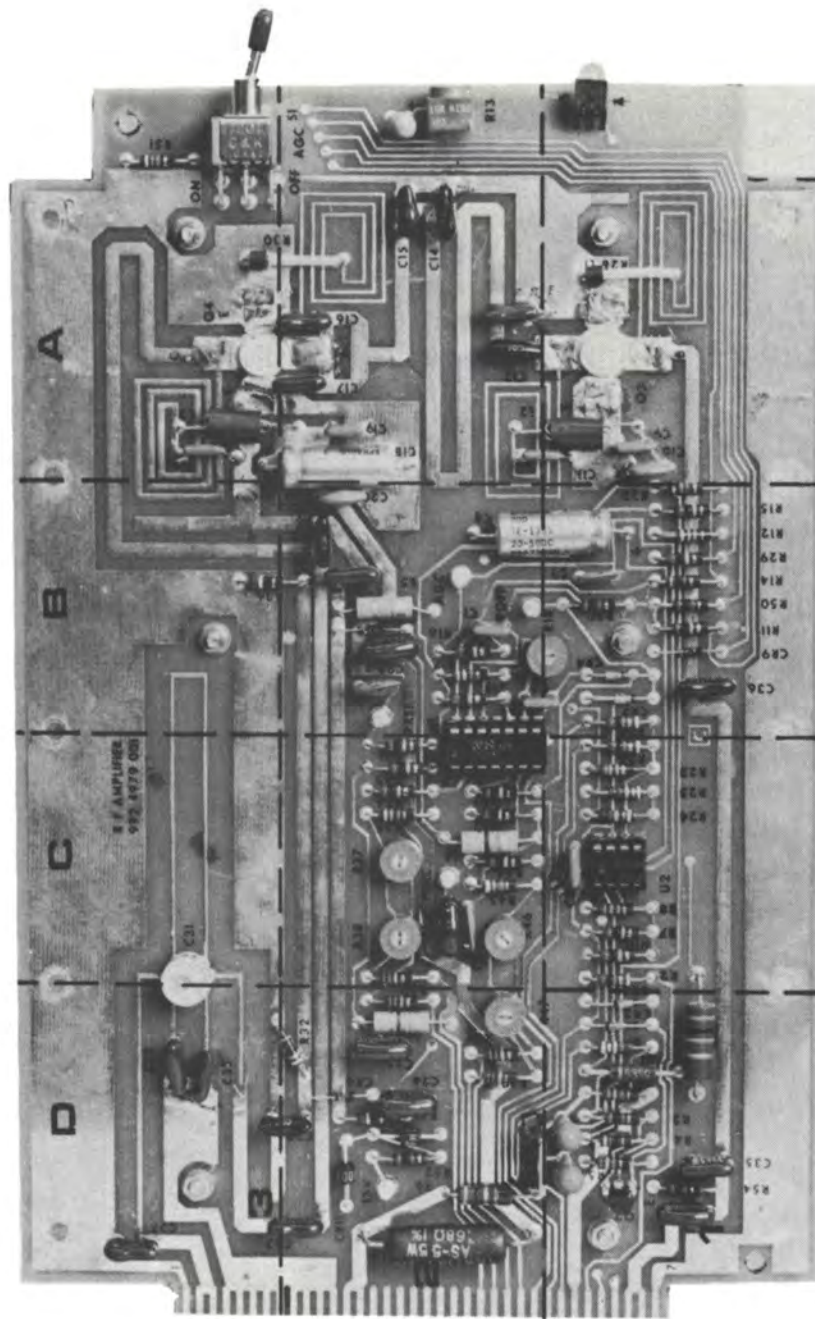

1742-49

Figure 5-1. RF AMP MODULE Parts Layout

Table 5-2. RF AMP MODULE Parts Index

SYMBOL	LOCATION	SYMBOL	LOCATION	SYMBOL	LOCATION	SYMBOL	LOCATION	SYMBOL	LOCATION
C1	B2	C29	D2	Q4	A3	R17	B2		
C2	A2	C30	C2			R18	B2		
C3	B1	C31	C3			R19	B2		
C4	B2	C32	D3	L1	A1	R20	B1		
C5	D2	C33	D3	L2	A1	R21	D1		
C6	D1	C34	C1	L3	A3	R22	B1		
C7	D1	C35	D1	L4	D2	R23	C1		
C8	B2	C36	B1	L5	B2	R24	C1		
C9	A1	C37	D3	L6	C2	R25	C1		
C10	A1	C38	C2	L7	A3	R26	C1		
C11	A1					R27	B1		
C12	A2					R28	*		
C13	A2	CR1	D1	R1	D1	R29	B1		
C14	A2	CR2	D1	R2	C1	R30	*		
C15	A2	CR3	D1	R3	D1	R31	C2		
C16	A2	CR4	B1	R4	D1	R32	D2		
C17	A2	CR5	A1	R5	D1	R33	C2		
C18	A2	CR6	D2	R6	D2	R34	C2		
C19	A2	CR7	B1	R7	C1	R35	C2		
C20	B2	CR8	B2	R8	C1	R36	B3		
C21	A3	CR9	B1	R9	D2	R37	C2		
C22	B2	CR10	D2	R10	C1	R38	C2		
C23	D2	CR11	D2	R11	B1	R39	D2		
C24	B2			R12	B1	R40	D2		
C25	D2			R13	A2	R41	D2		
C26	D2	Q1	*	R14	B1	R42	C2		
C27	B2	Q2	D1	R15	B1	R43	C2		
C28	B2	Q3	A1	R16	B2	R44	C2		

Table 5-2. RF AMP MODULE Parts Index (Continued)

SYMBOL	LOCATION	SYMBOL	LOCATION	SYMBOL	LOCATION	SYMBOL	LOCATION
R45	C2						
R46	C2						
R47	D2						
R48	D2						
R49	D2						
R50	B1						
R51	A3						
R52	D2						
R53	D1						
R54	D1						
S1	A3						
U1	C2						
U2	C1						
U3	D2						
* Part of Exciter Power Supply.							

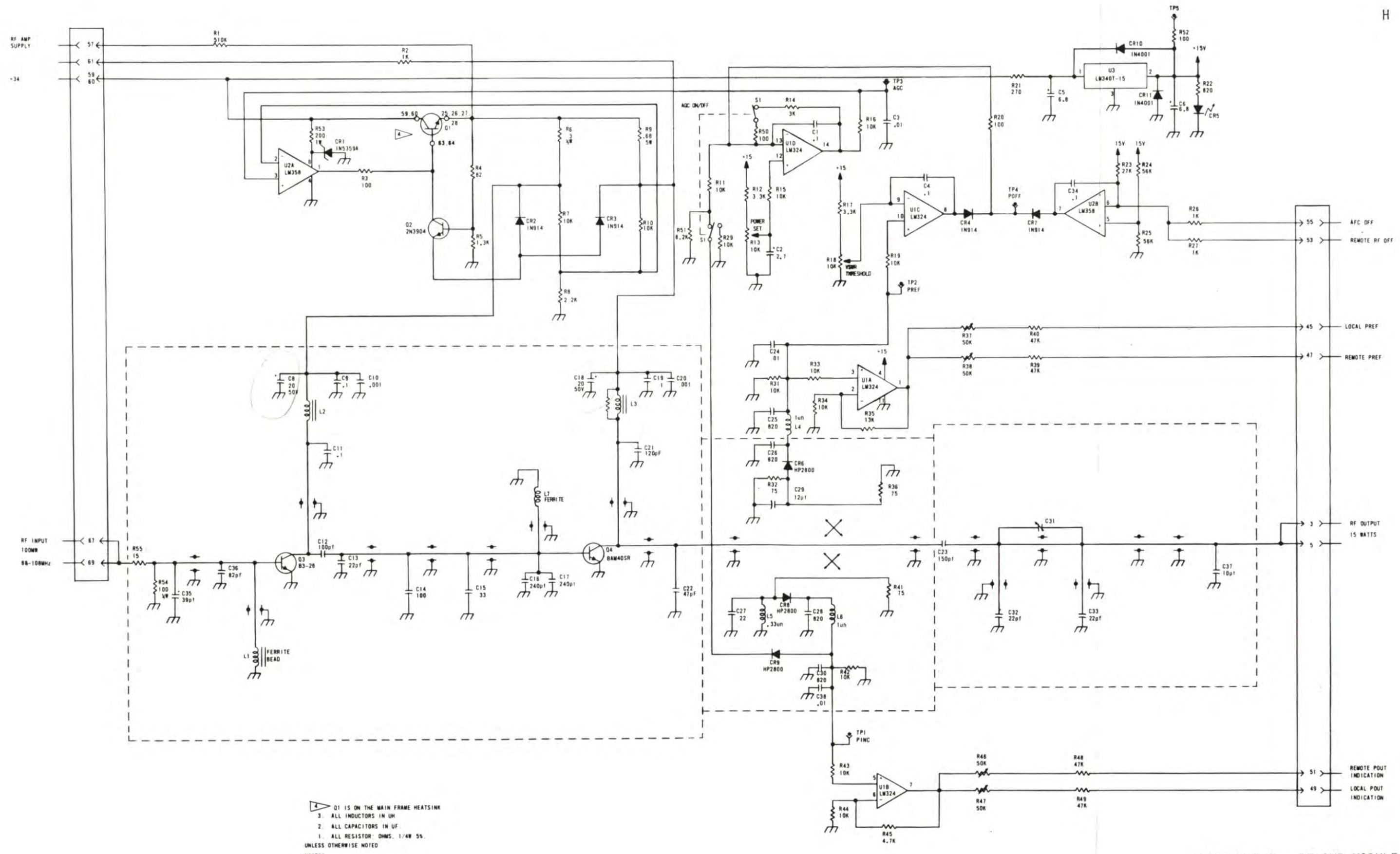

Q1 IS ON THE MAIN FRAME HEATSINK
 3. ALL INDUCTORS IN UH
 2. ALL CAPACITORS IN UF
 1. ALL RESISTOR OHMS. 1/4W 5%
 UNLESS OTHERWISE NOTED
 NOTES:

FIGURE 5-2. RF AMP MODULE SCHEMATIC 852 8396 001

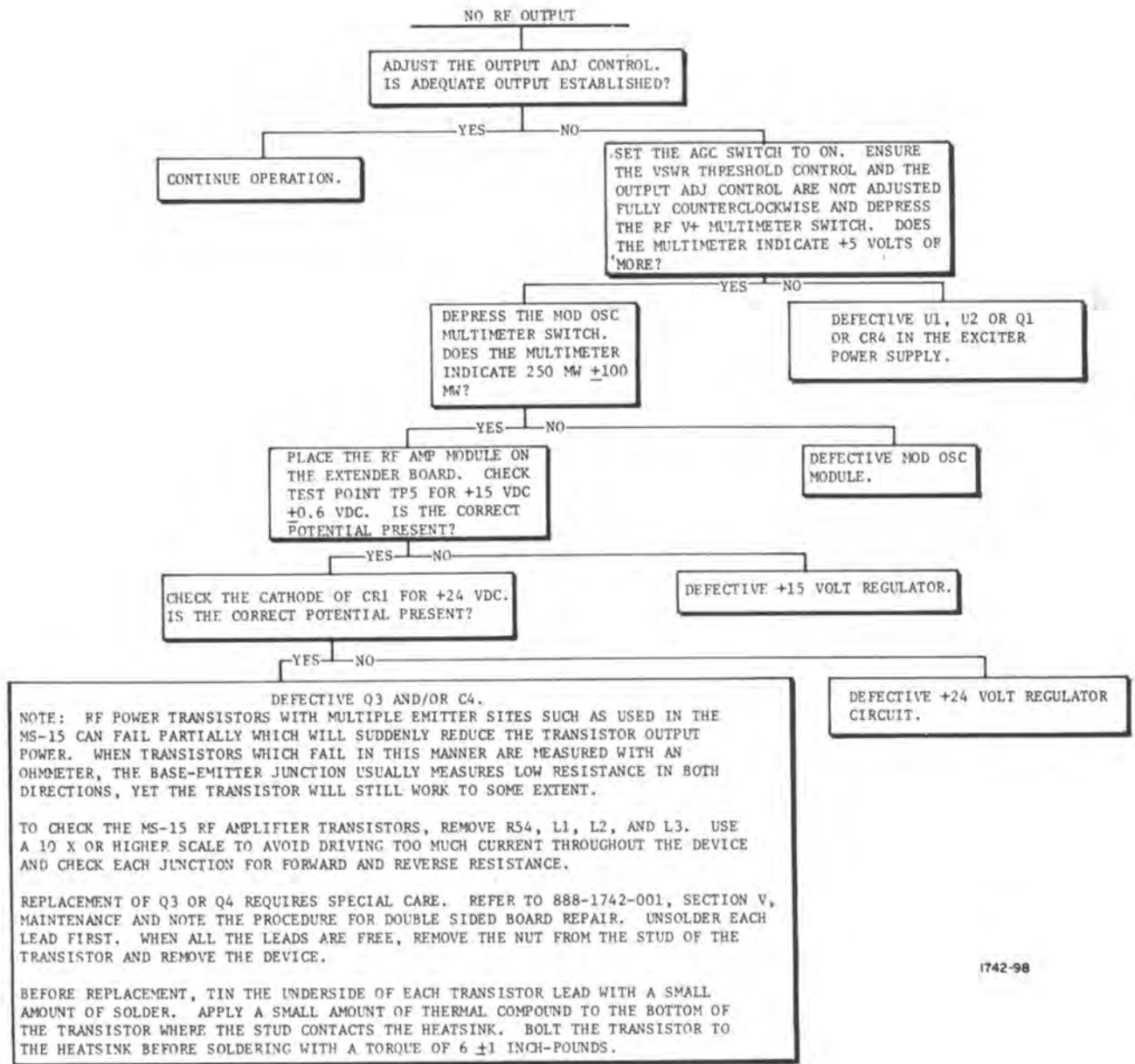

1742-98

Figure 5-3. No RF Output

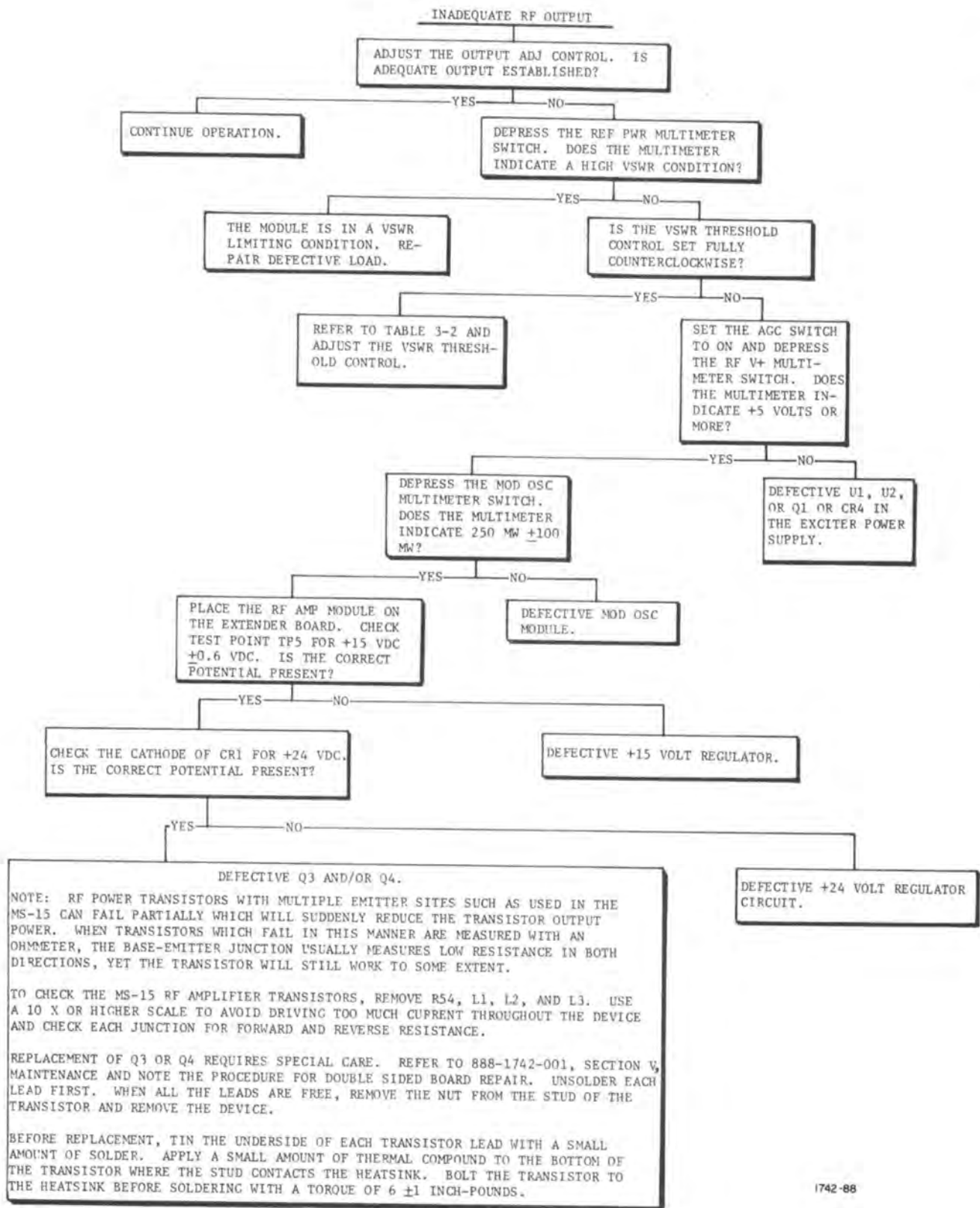
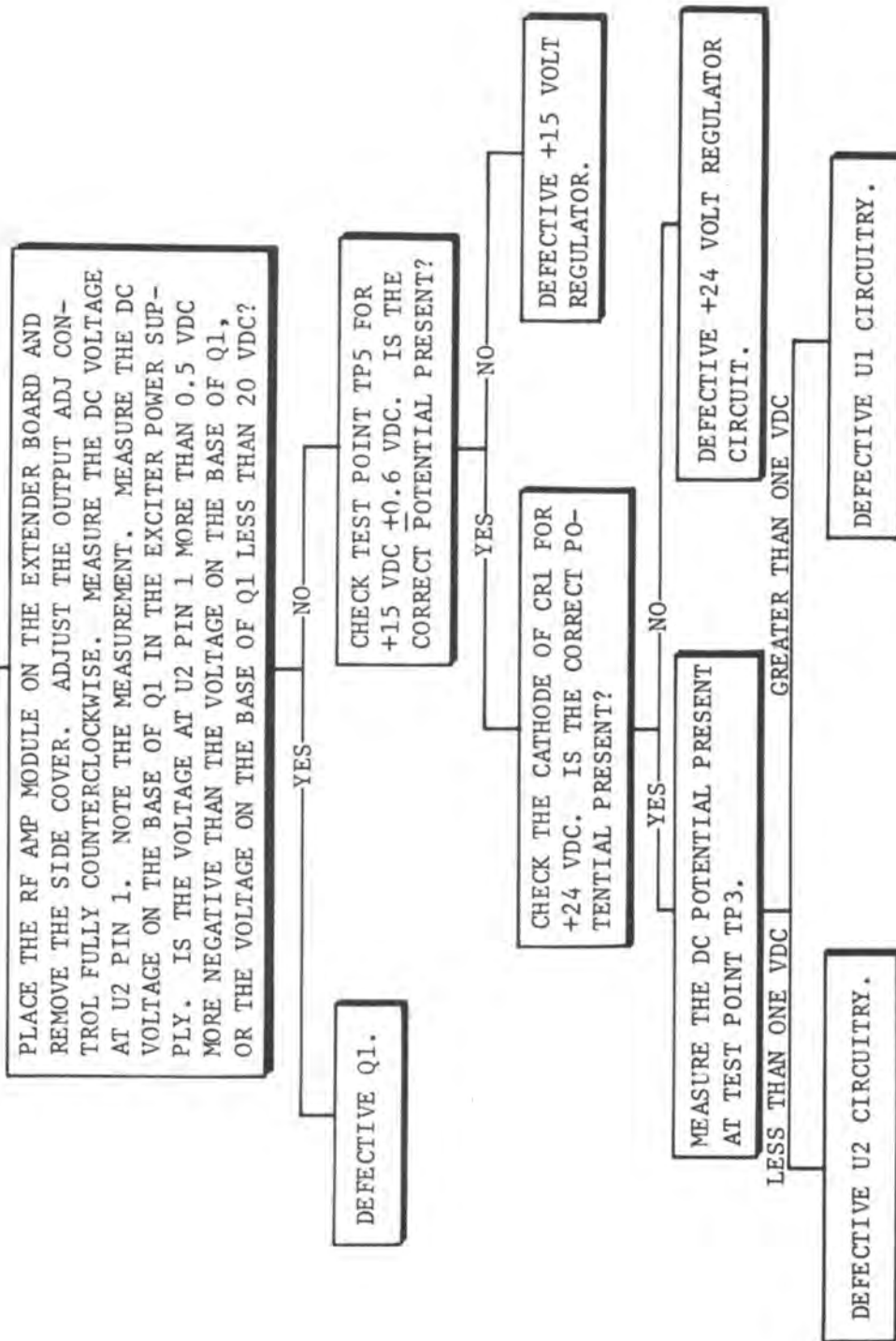

Figure 5-4. Inadequate RF Output

CANNOT REDUCE OUTPUT POWER



1742-87

Figure 5-5. Cannot Reduce Output Power

AM NOISE ON OUTPUT.

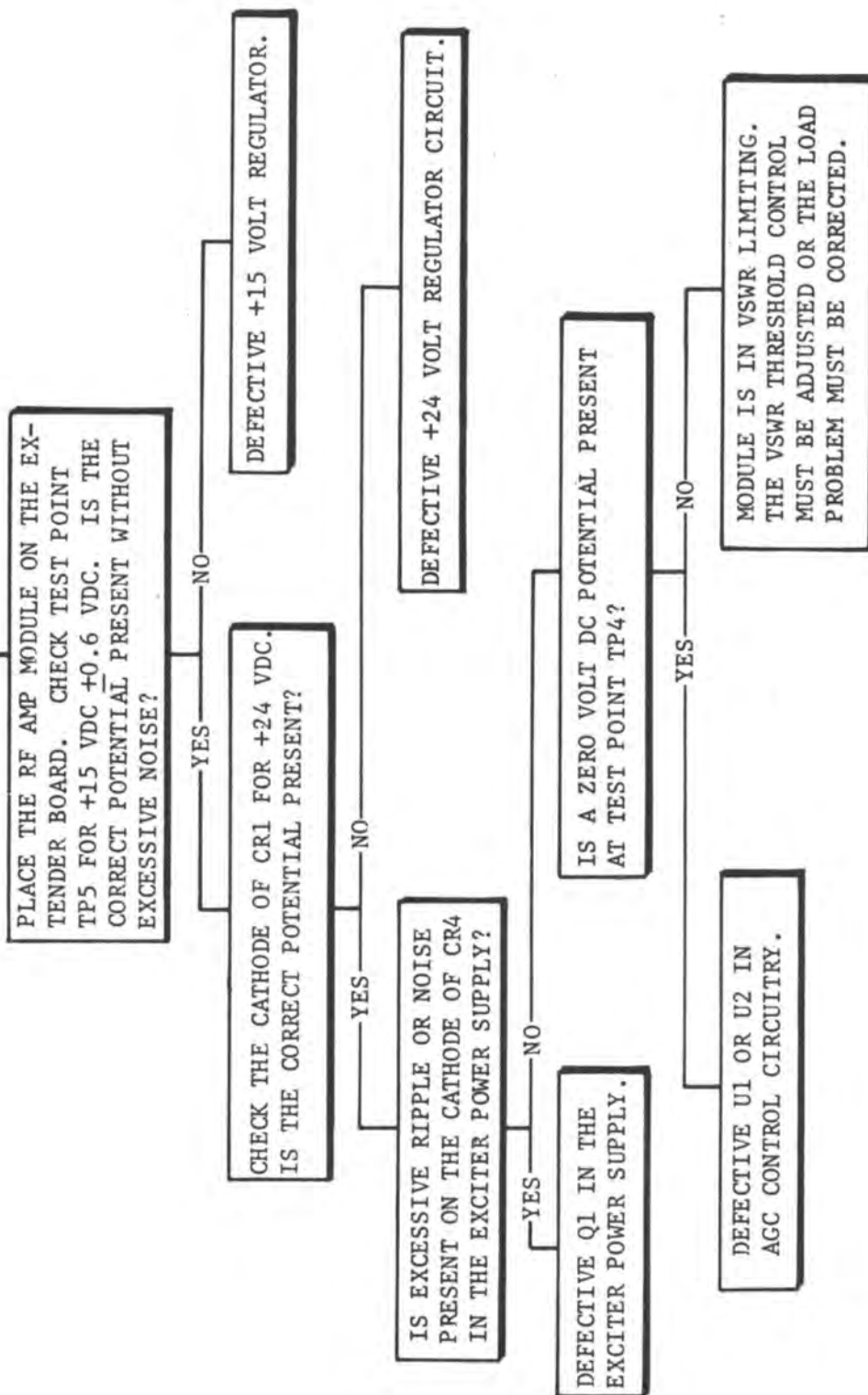

1742-85

Figure 5-6. AM Noise On Output

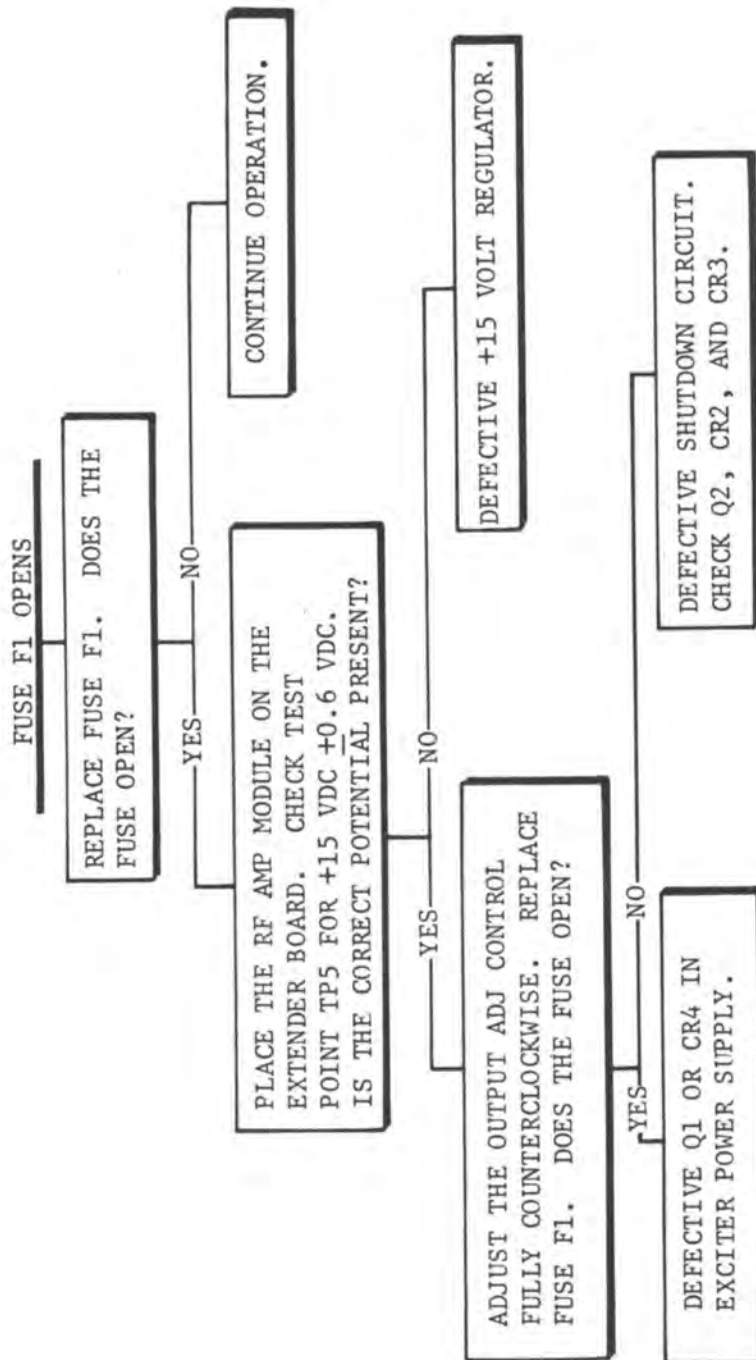

1742-86

Figure 5-7. Fuse F1 Opens

SECTION VI

PARTS LIST

6-1. GENERAL

6-2. Refer to table 6-1 for replaceable parts which are required for proper maintenance of the MS-15 RF AMP MODULE. Table entries are indexed by component reference designator.

Table 6-1. RF AMP MODULE Front Panel - 992 4978 001

REF. SYMBOL	HARRIS PART NO.	DESCRIPTION	QTY.
-----	992 4979 001	RF AMP MODULE Circuit Board (Refer to table 6-2)	1

Table 6-2. RF AMP MODULE Circuit Board - 992 4979 001

REF. SYMBOL	HARRIS PART NO.	DESCRIPTION	QTY.
C1	516 0453 000	Capacitor, 0.1 uF, 100V, 20%	1
C2	526 0342 000	Capacitor, 2.7 uF, 35V, 10%	1
C3	516 0375 000	Capacitor, 0.01 uF, 50V	1
C4	516 0453 000	Capacitor, 0.1 uF, 100V, 20%	1
C5,C6	526 0049 000	Capacitor, 6.8 uF, 35V, 20%	2
C8	522 0256 000	Capacitor, 20 uF, 50V	1
C9	516 0453 000	Capacitor, 0.1 uF, 100V, 20%	1
C10	516 0054 000	Capacitor, 0.001 uF, 1kV, Disc	1
C11	516 0453 000	Capacitor, 0.01 uF, 100V, 20%	1
C12	500 0759 000	Capacitor, 100 pF, Mica, 500V	1
C13	500 0809 000	Capacitor, 22 pF, 500V, Mica	1
C14	500 0759 000	Capacitor, 100 pF, Mica, 500V	1
C15	500 0813 000	Capacitor, 33 pF, 500V, Mica	1
C16,C17	500 0830 000	Capacitor, 240 pF, 500V, Mica	2
C18	522 0256 000	Capacitor, 20 uF, 50V	1
C19	516 0453 000	Capacitor, 0.1 uF, 100V, 20%	1
C20	516 0054 000	Capacitor, 0.001 uF, 1kV, Disc	1
C21	500 0826 000	Capacitor, 120 pF, 500V	1
C22	500 0817 000	Capacitor, 47 pF, 500V, Mica	1
C23	500 0761 000	Capacitor, 150 pF, Mica, 500V	1
C24	516 0375 000	Capacitor, 0.01 uF, 50V	1
C25,C26	500 0842 000	Capacitor, 820 pF, 300V, Mica	2

Table 6-2. RF AMP MODULE Circuit Board - 992 4979 001 (Continued)

REF. SYMBOL	HARRIS PART NO.	DESCRIPTION	QTY.
C27	500 0809 000	Capacitor, 22 pF, 500V, Mica	1
C28	500 0842 000	Capacitor, 820 pF, 300V, Mica	1
C29	500 0805 000	Capacitor, 12 pF, 500V, Mica	1
C30	500 0842 000	Capacitor, 820 pF, 300V, Mica	1
C31	518 0058 000	Capacitor, 5.5-18 pF, Variable	1
C32,C33	500 0809 000	Capacitor, 22 pF, 500V, Mica	2
C34	516 0453 000	Capacitor, 0.1 uF, 100V	1
C35	500 0815 000	Capacitor, 39 pF, 500V, Mica	1
C36	500 0823 000	Capacitor, 82 pF, 500V, Mica	1
C37	500 0804 000	Capacitor, 10 pF, 500V, Mica	1
C38	516 0375 000	Capacitor, 0.01 uF, 50V	1
CR1	386 0366 000	Diode, Zener, 1N5359A	1
CR2,CR3,CR4	384 0205 000	Diode, 1N914	3
CR5	384 0661 000	LED, Green	1
CR6	384 0321 000	Diode, Hot Carrier	1
CR7	384 0205 000	Diode, 1N914	1
CR8,CR9	384 0321 000	Diode, Hot Carrier	2
CR10,CR11	384 0284 000	Diode, 1N2070	2
L1	414 0087 000	Ferrite Bead	1
L2	494 0218 000	Choke, 180 mHz, Wide Band	1

Table 6-2. RF AMP MODULE Circuit Board - 992 4979 001 (Continued)

REF. SYMBOL	HARRIS PART NO.	DESCRIPTION	QTY.
L3	929 7155 001	Choke Assembly, 23 Turns <u>+1</u> Turn, (30 Inches/76.2cm) of No. 24 AWG Magnet Wire on a 2 Watt, 22 ohm, 5% Resistor (HARRIS P/N 540-0571-000)	1
L4	494 0384 000	Inductor, 1 uH	1
L5	494 0378 000	Inductor, 0.33 uH	1
L6	494 0384 000	Inductor, 1 uH	1
L7	414 0087 000	Ferrite Bead	1
Q2	380 0189 000	Transistor, 2N3904	1
Q3	380 0556 000	Transistor, B-3-28	1
Q4	380 0610 000	Transistor, BAM40SR	1
R1	540 0977 000	Resistor, 510k ohms, 1/4W, 5%	1
R2	540 0912 000	Resistor, 1000 ohms, 1/4W, 5%	1
R3	540 0888 000	Resistor, 100 ohms, 1/4W, 5%	1
R4	540 0886 000	Resistor, 82 ohms, 1/4W, 5%	1
R5	540 0915 000	Resistor, 1300 ohms, 1/4W, 5%	1
R6	540 0846 000	Resistor, 3 ohms, 1/2W, 5%	1
R7	540 0936 000	Resistor, 10k ohms, 1/4W, 5%	1
R8	540 0920 000	Resistor, 2.2k ohms, 1/4W, 5%	1
R9	548 1425 000	Resistor, 0.68 ohms, 5W, 1%	1
R10,R11	540 0936 000	Resistor, 10k ohms, 1/4W, 5%	2
R12	540 0924 000	Resistor, 3300 ohms, 1/4W, 5%	1
R13	550 0914 000	Potentiometer, 10k ohms	1

Table 6-2. RF AMP MODULE Circuit Board - 992 4979 001 (Continued)

REF. SYMBOL	HARRIS PART NO.	DESCRIPTION	QTY.
R14	540 0923 000	Resistor, 3k ohms, 1/4W, 5%	1
R15,R16	540 0936 000	Resistor, 10k ohms, 1/4W, 5%	2
R17	540 0924 000	Resistor, 3.3k ohms, 1/4W, 5%	1
R18	550 0922 000	Potentiometer, 10k ohms, 1/2W	1
R19	540 0936 000	Resistor, 10k ohms, 1/4W, 5%	1
R20	540 0888 000	Resistor, 100 ohms, 1/4W, 5%	1
R21	540 0898 000	Resistor, 270 ohms, 1/4W, 5%	1
R22	540 0910 000	Resistor, 280 ohms, 1/4W, 5%	1
R23	540 0946 000	Resistor, 27k ohms, 1/4W, 5%	1
R24,R25	540 0954 000	Resistor, 56k ohms, 1/4W, 5%	2
R26,R27	540 0912 000	Resistor, 1k ohm, 1/4W, 5%	2
R29	540 0936 000	Resistor, 10k ohms, 1/4W, 5%	1
R31	540 0936 000	Resistor, 10k ohms, 1/4W, 5%	1
R32	540 0885 000	Resistor, 75 ohms, 1/4W, 5%	1
R33,R34	540 0936 000	Resistor, 10k ohms, 1/4W, 5%	2
R35	540 0939 000	Resistor, 13k ohms, 1/4W, 5%	1
R36	540 0885 000	Resistor, 75 ohms, 1/4W, 5%	1
R37,R38	550 0929 000	Potentiometer, 50k ohms, 1/4W	2
R39,R40	540 0952 000	Resistor, 47k ohms, 1/4W, 5%	2
R41	540 0885 000	Resistor, 75 ohms, 1/4W, 5%	1
R42,R43,R44	540 0936 000	Resistor, 10k ohms, 1/4W, 5%	3
R45	540 0928 000	Resistor, 4.7k ohms, 1/4W, 5%	1

Table 6-2. RF AMP MODULE Circuit Board - 992 4979 001 (Continued)

REF. SYMBOL	HARRIS PART NO.	DESCRIPTION	QTY.
R46,R47	550 0929 000	Potentiometer, 50k ohms, 1/4W	2
R48,R49	540 0952 000	Resistor, 47k ohms, 1/4W, 5%	2
R50	540 0888 000	Resistor, 100 ohms, 1/4W, 5%	1
R51	540 0934 000	Resistor, 8.2k ohms, 1/4W, 5%	1
R52	540 0888 000	Resistor, 100 ohms, 1/4W, 5%	1
R53	540 0315 000	Resistor, 200 ohms, 1W, 5%	1
R54	540 0888 000	Resistor, 100 ohms, 1/4W, 5%	1
R55	540 0868 000	Resistor, 15 ohms, 1/4W, 5%	1
S1	604 0859 000	Switch, Toggle	1
U1	382 0415 000	Integrated Circuit, CA3246	1
U2	382 0428 000	Integrated Circuit, LM358P	1
U3	382 0359 000	Integrated Circuit, MC7815CP	1
XU1	404 0674 000	Socket, Integrated Circuit, 14 Contact	1
XU2	404 0673 000	Socket, Integrated Circuit, 8 Contact	1
	943 1599 001	Printed Board	1
	839 2919 001	Heat Sink	1