

INSTRUCTION BOOK  
FOR  
M5167 STA-LEVEL AMPLIFIER



*Gates Radio Company*

MANUFACTURING ENGINEERS SINCE 1922

QUINCY, ILLINOIS

If You Didn't Get This From My Site,  
Then It Was Stolen From...

[www.SteamPoweredRadio.Com](http://www.SteamPoweredRadio.Com)

INSTRUCTIONS

M-5167 STA-LEVEL AMPLIFIER

IB-727  
4/30/56  
Price: \$1.00

Gates Radio Company  
Quincy, Illinois

## M5167 STA-LEVEL AMPLIFIER

### SPECIFICATIONS

GAIN: 35 db,  $\pm 2$  db with input and output pads intact.

62 db,  $\pm 2$  db with input and output pads removed.

DISTORTION: 1% or less from 50 to 15,000 cycles, 0-30 db compression or gain reduction as read on compression meter.

RESPONSE:  $\pm 1$  db from 30 to 15,000 cycles, 0-30 db compression.

NOISE: 65 db or better below  $\pm 8$  dbm or higher output at any gain setting.

ATTACK/RECOVERY TIME: Factory wired for average programming. Time constants may be varied, if desired, with the values listed on page 2 of this section.

COMPRESSION RATIO AND THRESHOLD: The compression ratio is approximately 3.3:1 and the threshold is  $\pm 10$  to  $\pm 12$  dbm output as wired at the factory, with the output control at maximum. The meter is calibrated for this setting. See text for changing these levels and ratios.

IMPEDANCES: 500/600 ohms as wired at factory. Pad values may be changed to other impedances. If pads are removed, input and output may be connected 150/250 or 500/600 ohms with transformer connections.

TUBES: (2) 6V6, (1) 6386, 12AT7, 6AL5, OB2 and 5Y3GT.

POWER: 105/125 volts, 50/60 cycles, approximately 50 watts.

MECHANICAL: 5-1/4" high, 19" wide and 7" deep for standard rack mounting. Front panel drops down for access to components and meter zero set control. Weight, packed 30 pounds.

FINISH: Medium gloss gray with white lettering.

4/27/56

-1-

M5167 Sta-Level Amp.

RECOVERY TIME FOR STA-LEVEL AMPLIFIER

Time In Seconds

R36	R37	SINGLE	SINGLE	DOUBLE	DOUBLE	DOUBLE	DOUBLE
MEG.	MEG.	63%	90%	SLOW	SLOW	FAST	FAST
				63%	90%	63%	90%
1.5	1.5	2.25	10.0	2.0	8.0	.75	3.0
1.5	3.3	2.25	10.0	1.5	9.0	.75	3.0
1.5	4.7	2.25	10.0	1.1	8.0	.75	3.0
1.5	7.5	2.25	10.0	.90	6.0	.75	3.0
1.5	10.0	2.25	10.0	.80	3.0	.75	3.0
3.3	1.5	4.95	19.8	5.5	17.0	1.65	6.6
3.3	3.3	4.95	19.8	4.0	21.0	1.65	6.6
3.3	4.7	4.95	19.8	3.1	20.0	1.65	6.6
3.3	7.5	4.95	19.8	2.6	18.5	1.65	6.6
3.3	10.0	4.95	19.8	2.3	16.0	1.65	6.6
3.3	15.0	4.95	19.8	2.1	12.0	1.65	6.6
4.7	1.5	7.05	28.2	7.0	22.0	2.35	9.4
4.7	3.3	7.05	28.2	5.0	23.5	2.35	9.4
4.7	4.7	7.05	28.2	4.2	25.0	2.35	9.4
4.7	7.5	7.05	28.2	3.5	26.5	2.35	9.4
4.7*	10.0*	7.05	28.2	3.1	28.0	2.35	9.4
4.7	15.0	7.05	28.2	2.8	18.0	2.35	9.4
4.7	20.0	7.05	28.2	2.5	14.0	2.35	9.4
7.5	1.5	11.25	45.0	12.0	37.5	3.75	15.0
7.5	3.3	11.25	45.0	11.0	40.0	3.75	15.0
7.5	4.7	11.25	45.0	9.8	42.0	3.75	15.0
7.5	7.5	11.25	45.0	8.6	43.5	3.75	15.0
7.5	10.0	11.25	45.0	7.1	45.0	3.75	15.0
7.5	15.0	11.25	45.0	5.0	39.3	3.75	15.0
7.5	20.0	11.25	45.0	4.5	36.0	3.75	15.0

4/27/56

# M5167 STA-LEVEL AMPLIFIER

## INSTRUCTIONS

### INTRODUCTION

The Gates' M5167 Sta-Level Amplifier is an automatic gain amplifier designed to keep a constant average level in a program circuit. It is not an instantaneous peak limiter, and must be followed by a peak limiter for feeding a transmitter. However, it is an ideal companion unit for a peak limiter as it will keep the peak limiter operating within its optimum range with a large variation in the level from the signal source.

Four different applications are listed below to show the engineer the possible uses and to explain its operation so that other applications may be worked out.

- 1- The Sta-Level Amplifier may be used to automatically control the program level out of the speech input console. This relieves the operator from most gain riding operation and keeps correct level into telephone line and peak limiting amplifier.
- 2- Automatically adjusts for differences in level between console input channels. Microphone, turntable, remote, net and projector channels may be faded in or switched in with the attenuators set at the normal position, and the Sta-Level will adjust for sub-normal or abnormal conditions.
- 3- May be used as an automatic fader. Turntables may be faded down 20 or 30 db by adjusting microphone level higher than the turntable level when the microphone is used, and it will fade down the turntable to background level. After the announcement, the turntable will return to normal level automatically.
- 4- May be used to control the level on individual incoming remote lines, a very valuable feature during extended remote broadcasts. Remote amplifier may be adjusted 15 db below maximum level, the Sta-Level adjusted to mid-compression range, and the level will then be automatically controlled with  $\pm 15$  db level variation into the remote amplifier. This allows the console operator to attend to other duties during this time.

The Sta-Level Amplifier has built-in input and output attenuation to permit its use in most applications without external pads. The input volume control greatly extends the range of the input pad and allows precise adjustment of the input level. The output attenuator has a variable section to allow the output level to be precisely adjusted over the necessary range for most applications. Both variable controls are located on the front panel to permit rapid operation. The fixed sections of both attenuators are readily accessible, behind the hinged front panel, for change by the station engineer to accommodate other than standard values of attenuation

and/or impedances. Standard 1/2 watt resistors are used to change attenuator values.

Many other features and facilities are incorporated in the Gates' Sta-Level Amplifier. To prevent repetition, and allow full description of them, they will be covered in the following sections of the book.

## RECEIVING

The M5167 Sta-Level Amplifier is shipped with all parts, including the tubes, installed. Before installing, check for damage incurred in transit and be sure that all the tubes are secure in their sockets.

## INSTALLATION

The amplifier is 5-1/4" high, 19" wide and requires 9" rack depth. It has standard panel slots for rack mounting. The net weight is approximately 18 lbs. The unit should be mounted in a rack convenient for the operator and where the compression meter may be easily read. The unit can be operated without the use of the compression meter. For details refer to the section labelled "Operation". The compression meter may be removed from the panel, or a second meter connected in series with it, for a remote meter application.

After mounting the Sta-Level Amplifier in the rack, connect 115 volts (50/60 cycles) to terminals 7 & 8 on TB2. Use #18 AWG wire, or larger. Connect the input to TB1-1 & 3. The input impedance should be 600 ohms, balanced. Other impedances may be used if the attenuator section is changed by the station engineer. Connect earth and/or shield ground to TB1-2 and/or TB2-6. Both terminals connect to the amplifier chassis ground. Connect the output line to TB2-4 & 5. The Sta-Level Amplifier is factory connected for 600 ohms but may be changed by the station engineer by changing the output attenuator section, if desired.

The input and output wiring should be in shielded, twisted pair. They may both run in the same medium level cable if the attenuator sections are left intact. In applications utilizing maximum gain, with the attenuator sections removed, the input and output wiring must be separated and run in cables with the appropriate level classification.

Drawing A-11361 shows the suggested application of the Sta-Level Amplifier for general use. It is the first application listed under "Introduction". The second and third applications listed in this section also require wiring as shown on drawing A-11361. The fourth application listed, requires the amplifier to be installed in the individual incoming lines and presents no detail in explanation. Another possible application is to feed the output of the console into the Sta-Level Amplifier, and connect the Sta-Level to the telephone line or into the peak limiting amplifier. However,

the application shown on drawing A-11361 is certainly the most versatile and will allow full use of the amplifier. The use of patch panels or input and output switching will extend the possibilities even more, but will increase the chance for operational errors.

## OPERATION

The Sta-Level Amplifier is automatic in most of the applications and after the initial set-up requires little attention. Allow the unit to warm up a few minutes before attempting to calibrate the system. The application described on drawing A-11361 will be covered; other applications will be covered only if they differ greatly from this.

With no signal into the amplifier, adjust the compression meter to zero on the scale with the meter control. This is located back of the panel on a bracket by the meter movement. Reduce the output level of the console program amplifier 10 db from normal level. Advance the input control on the Sta-Level Amplifier until the meter is reading 15, the heavy double weight line on the compression meter. It is best to make this adjustment with program material, adjust the input level so that the meter reads 15 on peaks.

With the compression meter peaking on 15, adjust the output level control on the Sta-Level Amplifier until the console VU meter peaks to 0 VU or 100% modulation. This setting allows the Sta-Level to operate in its mid-range and adjust for levels 15 db below normal or 15 db above normal. You will notice that the output VU meter will read about 4 db low with input levels 15 db below normal, about 4 db high with input levels 15 db above normal. This slight change in the VU meter reading will allow normal console operation without watching the compression meter if it is not in an accessible position.

The operating levels of the system do not require constant surveillance when the Sta-Level Amplifier is in use. It will actually compress up to 40 db with very low distortion, which allows an additional 10 db safety factor over the normal range of 30 db. Amplifiers in the system ahead of the Sta-Level Amplifier will probably not operate over this extreme range, thus the levels may have to be reduced or kept within maximum limits by the operator.

Different types of program material require different recovery times on automatic gain type amplifiers. The Sta-Level Amplifier has a front panel switch, marked "Double" and "Single", to change the recovery time. In the Single position, the recovery time is fixed and does not change much with occasional short peaks or steady re-occurring peaks. It is slow in recovering from heavy peaks and is best used on classical music or material requiring the most dynamic range. The attack time is slower in the Single position also, at least 75 milli-seconds is required to cause compression.

4/27/56

-5-

M5167 Sta-Level Amp.

For speech and most popular music it is best to use the Double recovery time position. In this position the recovery time is largely a function of the type program material used. Most speech and other short occasional peaks have a rapid recovery time and the average level of modulation is kept very high. Music with long passages or similar program material will result in a slower recovery time automatically, thus retaining most of the dynamic range. The attack time is down to 25 milli-seconds in the Double position.

It is best to use the Sta-Level before putting it on the air the first time, to determine the best position of the recovery time switch on different types of program material. If all the operators are fully familiar with the operation, they will be able to use the unit to full advantage.

## PRINCIPLES AND THEORY OF OPERATION

The amplifier is the gated automatic gain type, using rectifier signal to increase the bias voltage on the variable mu tube, thus reducing the gain. Push-pull stages are used throughout to cancel the bias thump and to prevent motor-boating. Negative feedback is used to balance the output stages; V2, V3 and V4. This reduces the noise and distortion and makes tube selection far less critical. V1 is a premium tube with good balance between sections and does not require feedback.

The input pad is rated at approximately 20 db. It is a balanced H type and is installed to prevent overloading of the input transformer with high signal levels. Levels as high as  $\sqrt{24}$  dbm may be fed into the amplifier terminals without distortion with this pad installed. If the pad is removed, the maximum line input level is  $\sqrt{4}$  dbm and the amplifier gain is increased approximately 20 db.

The output pad is rated at approximately 10 db minimum to 16 db maximum. One side of the shunt value is variable to achieve this 6 db level adjustment. This pad has been carefully tested to assure that the small impedance mis-match resulting from this range adjustment will not affect frequency response or other characteristics. If the value or impedance of the pad is changed by the station engineer, he must be sure that the pad retains these qualities. It may be necessary to reduce the value of the variable resistance by adding a shunt resistor across it when reducing the attenuation of the pad from the factory value. Increasing the attenuation may call for a change in the variable section also.

If both pads are removed, the maximum gain of the amplifier will increase up to approximately 62 db. In certain applications this is desirable to eliminate the use of a line or program amplifier. The minimum input threshold of compression is approximately -44 dbm under these conditions. The mid-range input level for 15 db of compression would be about -30 dbm. The output level would be approximately  $\sqrt{24}$  dbm with 15 db of compression. Of course, either the input or output pad could be removed without removing the other if the application demanded.

4/27/56

-6-

M5167 Sta-Level Amp.



V1A, V1B, V2A, V2B, V3 and V4 are connected in the conventional way for a push-pull amplifier. The stages are R-C coupled and negative feedback is taken from the plates of the output stage back to the cathodes of the second stage. The output of the 6V6 stage is also fed to the cathodes of V6, where rectification occurs if the peak signal exceeds the positive bias applied. Normally, the bias voltage is  $\sqrt{25}$  volts. The RMS value of signal voltage at this point must exceed 17.5 volts to cause rectification since the peak value of 17.5 volts RMS is approximately 25 volts.

This would be the threshold of compression and signals above this point are rectified and applied to the grid return of V1. This bias voltage is approximately -2.4 volts for 5 db compression, -6V:10 db, -11.6V:15 db, -19V: 20 db, -30.5V: 25 db, -43V: 30 db, -59V: 35 db and -76V. for 40 db of compression. From these figures you can see that the bias to compression ratio is not a linear function. Drawing A-11734 shows this function by the rising characteristic of the curve at the higher compression figures.

The compression ratio may be increased up to 6:1 instead of 3.3:1 by raising the bias on the cathode of V6. The bias may be raised by increasing the value of R32, the 24,000 ohm resistor. The output and input levels of the amplifier must be raised to start the compression action and the distortion will increase along with these levels. The reason the compression ratio is changed is because the RMS voltage is increased logarithmically with the increase in level in db. The rectified bias is still a function of the RMS voltage. Thus, it does not require such a change in db to obtain the required bias level with high signal levels as with low signal levels.

If the bias point is reduced below  $\sqrt{25}$  volts the compression ratio will become lower than 3.3:1. Ratios as low as 1.6:1 are practical under certain types of operation. This means that with 16 db increase on the input, the output would increase 10 db. Thus, the amplifier would not be a great aid in keeping a constant level in the output. The bias may be reduced by reducing the value of R32 from 24,000 ohms to the selected value.

The 3.3:1 compression ratio and the associated output threshold level of  $\sqrt{10}$  to  $\sqrt{12}$  dbm with the output pad at minimum attenuation (or  $\sqrt{20}$  to  $\sqrt{22}$  dbm output with the output pad removed), appears to be the optimum value for general use. The use of a control to adjust this bias point does not seem wise since it could easily be set to the wrong point if changed in a hurry without proper checking of the operation. This is a DC circuit and can be wired to a bias selector switch if it is desired to install one. A control may also be installed by the engineer if he desires one and will prevent mal-operation.

4/30/56

-7-

M5167 Sta-Level Amp.

The attack and recovery time constants are listed on page 2 of the Specifications. Again average values were chosen for normal operation. These values are marked (\*) for a reference point and may be changed to suit the individual application. In the Single position of the switch, C10 and C11 are in parallel. The attack time is determined by their capacity and R35 (56 ohms). The recovery time is determined by R36. The time may be calculated by multiplying R (in megohms) and C (in microfarads). Thus, .05 times 1.5 is .075 or 75 milli-seconds for the attack time. And 4.7 times 1.5 is 7.05 seconds for 63% recovery, times 4 or 28.2 seconds for 90% recovery. This basic R-C formula checked very closely with the actual circuit timing in tests and may be considered adequate for calculating other circuit values.

In the Double position of the recovery time switch the problem becomes much more complex, however. Rather than work with the dual recovery times of the two circuits involved, the figures listed in the chart are actual measured time. With single short peaks or a few short peaks, the recovery time is fast because very little charge is stored in C11. With sustained peaks C11 does charge up and must discharge through R37 and R36 in series. These resistors actually form a voltage divider that is paralleled with the voltage dividing action of C11 and C10. Thus, an extreme range of recovery time may be achieved by changing the resistance values as indicated by the chart. The attack time is not affected by C11 in the double position, thus, it is .05 times .5 (.025) or 25 milli-seconds under any type of program material.

V5 is a voltage regulator tube with 105 volts regulation. It is adjusted to draw approximately 5 MA and it is necessary to look closely to see it glow. It can be seen by looking at the base of the tube when it is shielded from an external light source. Its purpose is to prevent the bias point from shifting with the line or supply voltage.

C13 is inserted from the center-tap of the filament winding to ground to bias the filaments above the cathode voltage of the tubes. Since the highest cathode voltage is on the 6V6 tubes, the filament bias will be a few volts more positive, due to filament-cathode rectification. After the initial rectification which charges the capacitor to peak value, there is no more current flow from filament to cathode and thus little or no hum induced in the tubes from this flow. Grounding either side of the filaments will cause serious hum in the amplifier. Even grounding the center-tap of the filament winding will result in much more than normal hum in most applications. This is a good check to make if the amplifier is noisy and new tubes will not correct the noise.

4/30/56

- 8 -

M5167 Sta-Level Amp.

## MAINTENANCE

One of the best aids in maintenance is the tabulation of socket voltages with a particular test meter. We have the voltages tabulated but if the meter used in the field is not the same impedance or has considerable error, our voltages would not help much. Unless specifically requested, we do not feel it is best to issue these voltage readings.

After the unit has operated for a period long enough to stabilize (1/2 hour or more) take all the readings with your best meter. A vacuum tube meter is preferred to prevent circuit loading but a 20,000 ohm per volt or even 5,000 ohm per volt will suffice if used for future checking. It is best to record which meter scale was used for the various readings since the loading is a function of the switch position on low impedance meters. Make one set of readings with no signal applied. Make another set with 15 db of compression. Readings with other degrees of compression would be valuable but not actually required.

Recording of signal levels throughout the amplifier will also help when trouble-shooting. It will point out tube difficulties that no tube tester can match. Always record all the pertinent data, such as input level, amount of compression, output level and line voltage.

With the data recorded as suggested above, maintenance is very easily accomplished. All the components are operated far below their maximum ratings thus will not fail due to circuit defects. A periodic check of the socket voltages and signal voltages against the tabulated chart will show any deterioration in ample time for correction before actual trouble occurs. Allow 20% variation on socket voltages with series resistors in the circuit. All tubes are not exactly alike and the circuit is designed to permit more than normal tolerances. Read the other descriptive sections when trouble shooting. The answer you seek will probably be there.

4/30/56

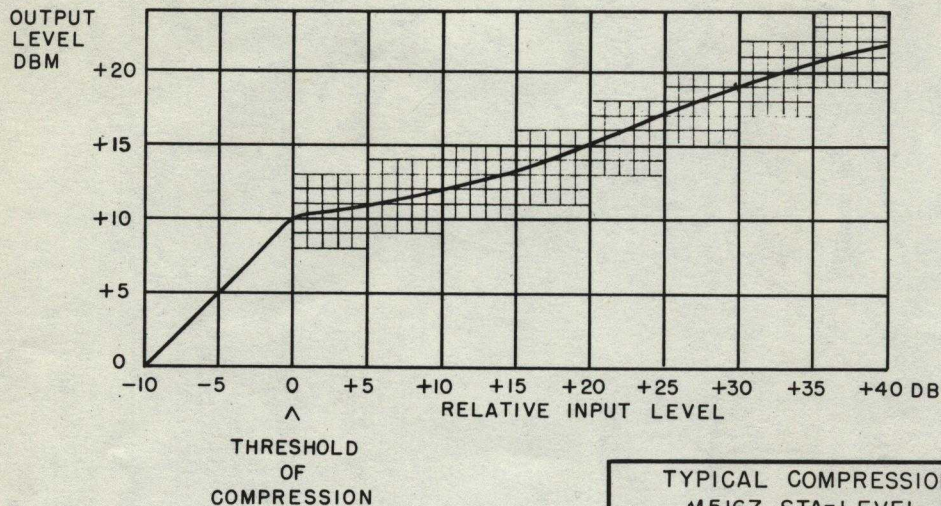

TYPICAL COMPRESSION CURVE ON  
M5167 STA-LEVEL AMPLIFIER

MTL		FIN.		UNLESS OTHERWISE SPECIFIED, ALL TOLERANCES PER GATES SPEC GSMI02.
DR. BY D.L.	CH. BY W.K.	ENG. APR. 1956	DATE 4-9-56	
DATE 4-4-56	DATE 4-7-56	DATE 4-9-56		A-11734
GATES RADIO COMPANY QUINCY, ILLINOIS				

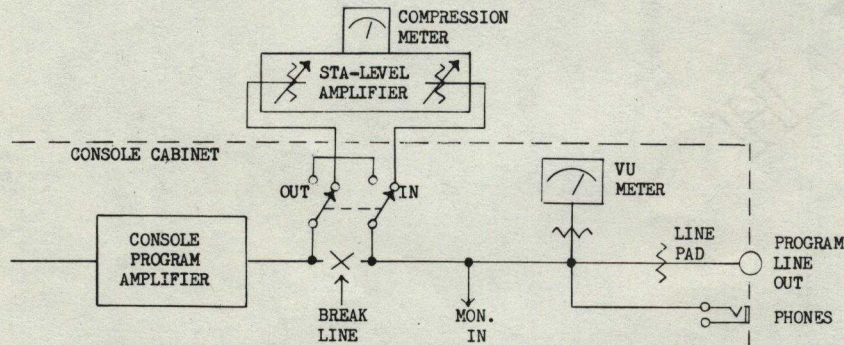

Almost any console is easily modified for use with Gates' STA-LEVEL Amplifier as shown above. Simply remove the output from the console program amplifier, as shown by the break, and connect to the input terminals of the STA-LEVEL Amplifier. Connect the output of the STA-LEVEL Amplifier to the output circuit of the console. The use of a console utility switch, or an external switch, will allow the STA-LEVEL Amplifier to be switched in or out of the circuit as desired.

With the STA-LEVEL Amplifier connected as shown, it will keep a controlled level into the telephone line, monitoring amplifier input, monitoring phones and all other circuits bridging the output of the console. The variable input and output attenuation of the STA-LEVEL Amplifier permits unity gain operation or reduction of the program amplifier level for higher over-load factor. The program amplifier level may be easily reduced with the master gain control on the console.

With the STA-LEVEL Amplifier operating normally at mid range, or 15 db compression, the input level may change  $\pm 15$  db with approximately  $\pm 4$  db change into the telephone line. This small change in the output level is easily handled by the telephone line and the peak limiting amplifier at the transmitter.

ONE SUGGESTED APPLICATION OF THE M5167  
STA-LEVEL AMPLIFIER

MTL		FIN.		UNLESS OTHERWISE SPECIFIED, ALL TOLERANCES PER GATES SPEC GSMI02.
DR. BY WJK	CH. BY WJK	ENG. APR. 1956	DATE 12-23-55	
DATE 12-23-55	DATE	DATE 12-23-55		A-11361
GATES RADIO COMPANY QUINCY, ILLINOIS				

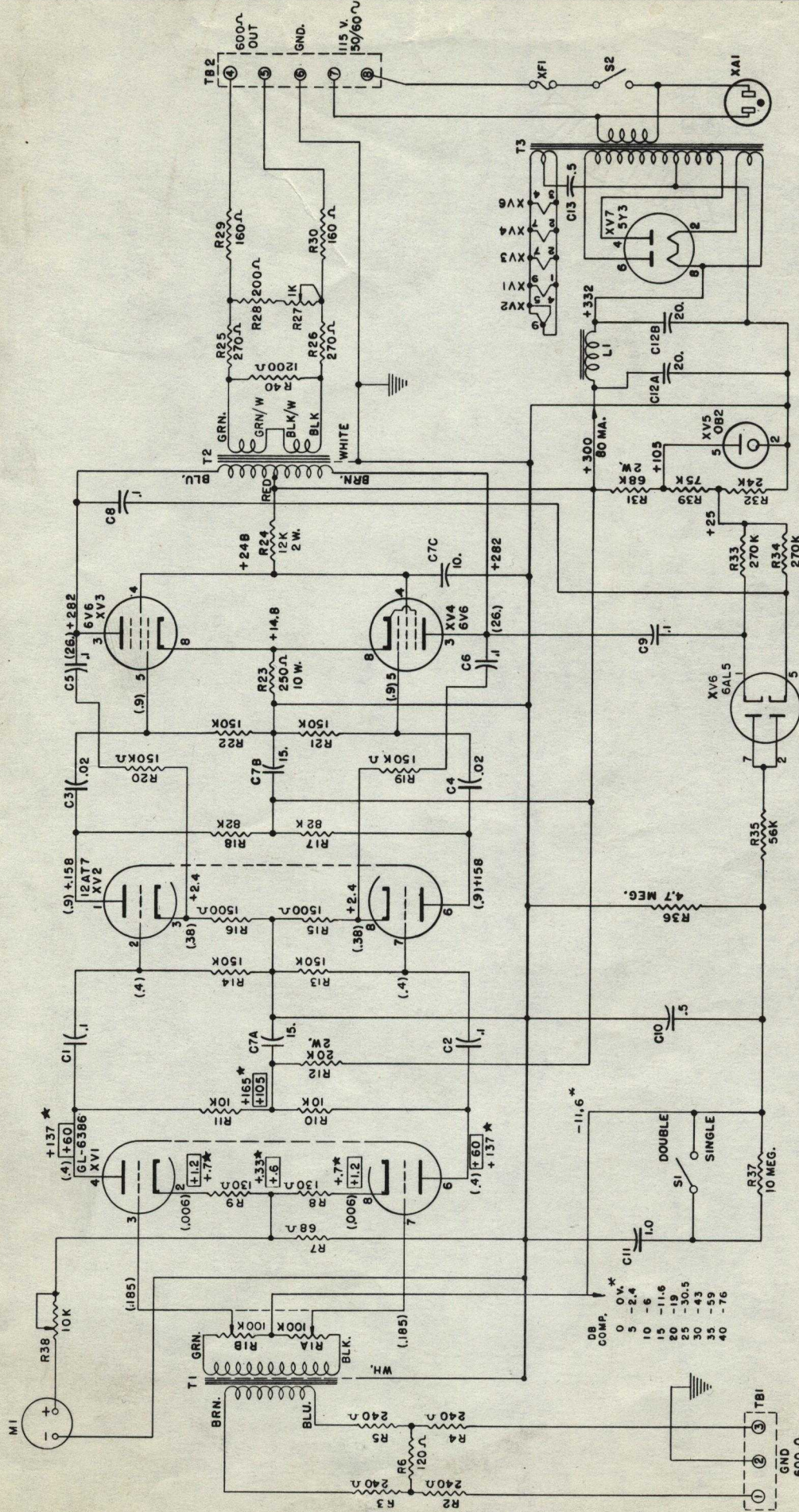

NOTE: D.C. MEASUREMENTS TAKEN WITH 20,000 Ω/VOLT METER +60, +332, ETC. SIGNAL VOLTAGES TAKEN WITH V.T.V.M. (.185), (.26), ETC. (RMS VALUES) ALLOW AT LEAST 20% VARIATION. MOST IMPORTANT TO MAINTAIN GOOD PUSH-PULL BALANCE. \* TAKE WITH D.C. V.T.V.M.

NOTE: ALL MEASUREMENTS TAKEN WITH 15 DB COMPRESSION, EXCEPT ±60 WHICH IS TAKEN WITH NO COMPRESSION. AT THESE POINTS THE "15 DB COMP." READINGS ARE MARKED \* OTHER D.C. READINGS DO NOT CHANGE.

DB COMP.	0	0.4*
	5	-2.4
	10	-6
	15	-11.6
	20	-19
	25	-30.5
	30	-43
	35	-59
	40	-76

If You Didn't Get This From My Site, Then It Was Stolen From...

WTL FIN. DATE: 1-25-53  
 DR BY: A.W. CH BY: GSK ENG: APB  
 DATE: 1-25-53 DATE: 1-25-53  
 STA - LEVEL AMPLIFIER M5167  
 DRAWING NO. C-19530  
 GATES RADIO COMPANY  
 QUINCY, ILLINOIS

## PARTS LIST

## "STA-LEVEL" LIMITING AMPLIFIER

<u>Symbol No.</u>	<u>Drawing No.</u>	<u>Description</u>
A1		Neon Lamp
C1, C2; C5, C6, C8, C9 C7 C10, C13 C11 C12 C3, C4		Capacitor, .1 mfd., 400(W)V. Capacitor, 15-15-10 mfd., 450V. Capacitor, .5 mfd., 200(W)V. Capacitor, 1.0 mfd., 200(W)V. Capacitor, 20-20 mfd., 450V. Capacitor, .02 mfd., 400(W)V.
F1		Fuse, 2 Amp.
L1		Filter Choke
M1	A-11308-101	Compression Meter
R1 R2, R3, R4, R5 R6 R7 R8, R9 R10, R11 R12 R13, R14, R19, R20, R21, R22 R15, R16 R17, R18 R23 R24 R25, R26 R29, R30 R27 R28 R31 R32 R33, R34 R35 R36 R37 R38 R39 R40	A-5544-2	Dual Control, 100K ohm Resistor, 240 ohm, 1/2W., 5% Resistor, 120 ohm, 1/2W., 5% Resistor, 68 ohm, 1/2W., 10% Resistor, 130 ohm, 1/2W., 5% Resistor, 10K ohm, 1W., 10% Resistor, 20K ohm, 2W., 5% Resistor, 150K ohm, 1/2W., 10% Resistor, 1500 ohm, 1/2W., 10% Resistor, 82K ohm, 1/2W., 10% Resistor, 250 ohm, 10W. Resistor, 12K ohm, 2W., 10% Resistor, 270 ohm, 1/2 W., 5% Resistor, 160 ohm, 1/2W., 5% Control, 100 ohm Resistor, 200 ohm, 1/2W., 5% Resistor, 68K ohm, 2W., 10% Resistor, 24K ohm, 1W., 5% Resistor, 270K ohm, 1/2W., 10% Resistor, 56K ohm, 1/2W., 10% Resistor, 4.7 megohm, 1/2W., 10% Resistor, 10 megohm, 1/2W., 10% Control, 10K ohm Resistor, 75K ohm, 1W., 5% Resistor, 1200 ohm, 1/2W., 5%
S1, S2	A-3404-30 A-3404-18	Switch

4/27/56

-1-

M5167 Sta-Level Amp.

<u>Symbol No.</u>	<u>Drawing No.</u>	<u>Description</u>
T1	AI-10386T	Input Transformer
T2	AO-11302T	Output Transformer
T3	AP-11303T	Power Transformer
TB1		Terminal Board
TB2		Terminal Board
V1		Tube, GL-6386
V2		Tube, 12AT7
V3, V4		Tube, 6V6GT
V5		Tube, 0B2
V6		Tube, 6AL5
V7		Tube, 5Y3GT
XA1		Pilot Light Assembly (Red)
XF1		Fuseholder
XV1, XV2		Socket
XV3, XV4, XV7		Socket
XV5, XV6		Socket

Ford switch  
5 B M - 087679