

C-QUAM®
STEREO SYSTEM
INSTALLATION
(Preliminary Manual)



4
39
x 5

195

DELTA ELECTRONICS



DELTA ELECTRONICS, INC.
5730 GENERAL WASHINGTON DRIVE
ALEXANDRIA, VIRGINIA 22312

If You Didn't Get This From My Site,
Then It Was Stolen From...

www.SteamPoweredRadio.Com

C-QUAM[®]
STEREO SYSTEM
INSTALLATION
(Preliminary Manual)

EXCITER MODEL ASE-1
MODULATION MONITOR MODEL ASM-1
FCC I. D. DK767C1300



DELTA ELECTRONICS, INC.
5730 GENERAL WASHINGTON DRIVE
ALEXANDRIA, VIRGINIA 22312

[®]C-QUAM is a registered trademark of
Motorola, Inc. Delta C-QUAM system
equipment is manufactured under
license from Motorola, Inc.

ISSUE DATE: 15 MAY 1984

CERTIFICATE OF WARRANTY

Delta warrants to Purchaser that the product it delivers will be free of defects in materials and be of good quality and workmanship.

This warranty applies to the period of one year from the date of delivery except for component parts purchased from other sources and assembled in Delta's production. Such component parts bear only the warranty of the manufacturer thereof in effect at the time of shipment to Purchaser.

Delta will, at its own expense and, after written notice has been received and acknowledged by Delta, repair or replace any product which proves to be defective (according to the usage of the trade) during the above designated warranty periods when such product is received by Delta at its Alexandria address with shipment costs prepaid by Purchaser.

Delta will not be liable for consequential damages.

No other warranty is expressed or implied.

GENERAL INFORMATION

SAFETY PRECAUTIONS

This Manual is intended for use by trained and qualified operating or service personnel who are familiar with the dangers inherent in handling potentially hazardous electrical and/or electronic circuits. It is not intended to contain a complete statement of all safety precautions which should be observed by personnel using this or other electronic equipment.

Avoid risking electrical shock in handling all circuits where substantial currents or voltages may be present.

The procedures outlined in this Manual are based on the information available at the time of publication. However, the manufacturer cannot assume liability with respect to technical application of the contents and shall, under no circumstances, be responsible for damage or injury (whether to person or property) resulting from its use.

REPLACEMENT PARTS

To obtain service replacement or warranty items, write or call Delta. Please supply Product Identification (Model Number and Serial Number) and Replacement Part Identification (including Stock Number and Description). Shipping of replacements may be unduly delayed if the necessary information is not supplied. A complete List of Materials is provided in this Manual.

EQUIPMENT DAMAGED IN TRANSIT

This item should be unpacked and inspected for damage WITHIN 15 DAYS after receipt. If concealed damage is discovered, immediately notify the carrier, confirming the notification in writing, and secure an inspection report. Report all shortages and damages to Delta at the location shown below.

Delta will file all claims for loss and damage on this equipment so long as the inspection report is obtained. Disposition of the damaged items will be furnished by Delta.

FIELD ENGINEERING SERVICE

Requests for installation, field engineering or service assistance should be directed to Delta.

TABLE OF CONTENTS

SECTION	TITLE	PAGE
	FOREWORD - What Is C-QUAM?	
1	INTRODUCTION	1-1
	1.1 Scope	1-1
	1.2 System Specifications	1-2
	1.3 ASE-1 Stereo Exciter Description	1-3
	1.4 ASM-1 Modulation Monitor Description	1-8
2	EQUIPMENT CHECKOUT AND INITIAL TESTS	2-1
	2.1 Chassis Inspection	2-1
	2.2 Mechanical Checkout	2-1
	2.3 Required Test Equipment	2-3
	2.4 Closed Loop Tests	2-4
3	MONITOR MEASUREMENTS OF BROADCAST TRANSMITTER	3-1
	3.1 Introduction	3-1
	3.2 Procedures	3-1
4	ASE-1 RF CONNECTIONS TO BROADCAST TRANSMITTER	4-1
	4.1 Introduction	4-1
	4.2 Discussion	4-1
5	ASE-1 AUDIO CONNECTIONS TO BROADCAST TRANSMITTER	5-1
	5.1 Introduction	5-1
	5.2 Phasing ASE-1 Output to the Transmitter	5-1
	5.3 Adjusting the Delay Networks	5-2
	5.4 Equalization Adjustments	5-4
	5.5 Separation Checks	5-5
	5.6 Operation into the Antenna	5-6
6	ASE-1/ASM-1 STEREO SYSTEM EQUIPMENT PERFORMANCE MEASUREMENTS	6-1
	6.1 Introduction	6-1
	6.2 Procedure	6-1
7	LIST OF MATERIALS	7-
8	ILLUSTRATIONS AND SCHEMATIC DIAGRAMS	8-1
APPENDIX A	FCC SECTION(S) 74.40 AND 73.128 (?)	A-
APPENDIX B	ASE-1/ASM-1 EQUIPMENT PERFORMANCE MEASUREMENT SAMPLE FORMS	B-1

LIST OF FIGURES

SECTION	TITLE	PAGE
FOREWORD	AMPLITUDE MODULATION	F-2
	PHASE MODULATION	F-4
	C-QUAM BLOCK DIAGRAM	F-6
1	EXCITER FRONT VIEW	1-3A
	EXCITER REAR VIEW	1-5A
	EXCITER CIRCUIT CARD LOCATION	1-5B
	EXCITER CIRCUIT CARD	1-7A
	EDGE CONNECTOR PIN IDENTIFICATION	
	MONITOR FRONT PANEL	1-8A
	MONITOR REAR PANEL	1-9A
	MONITOR CIRCUIT CARD LOCATION	1-10A
	MONITOR CIRCUIT CARD	1-12A
	EDGE CONNECTOR PIN IDENTIFICATION	
2	IDEAL OSCILLOSCOPE DISPLAY OF STEREO SIGNALS (5)	2-3A
	SAMPLE OSCILLOSCOPE DISPLAYS OF STEREO SIGNALS (6,7)	2-3B
	CLOSED LOOP EQUIPMENT ARRANGEMENT (1)	2-4A
	MATCHING PAD CONSTRUCTION (2)	2-5A
	L+R (AM) OPERATION-- OSCILLOSCOPE/SPECTRUM ANALYZER DISPLAYS	2-6A
	L-R INTO L+R (AM) OPERATION-- MINIMUM PERFORMANCE (8)	2-9A
3	L-R SIMULATED OSCILLOSCOPE X-Y DISPLAY (7)	3-2A
	L+R INTO L-R OPERATION-- MINIMUM PERFORMANCE (8)	3-3A
	ASE-1 CONNECTING CIRCUITRY-- TRANSISTOR (9)	4-2A
	ASE-1 CONNECTING CIRCUITRY-- TUBE RF (10)	4-3A
5	PHASING OF BROADCAST TRANSMITTER AUDIO INPUT (11)	5-1A
6	BLOCK DIAGRAM OF TEST ARRANGEMENT	6-2A

LIST OF FIGURES CONTINUED

SECTION	TITLE	PAGE
8	BLOCK DIAGRAM (EXCITER)	D15-10
	AUDIO EQUALIZER MATRIX (DAY)	D33-320
	ENCODER	D33-319
	L+R AMPLIFIER/SAMPLE TRANSMITTER	D33-321
	RF AMPLIFIER	D33-322
	POWER SUPPLY	D33-323
	AUDIO NIGHT PROCESSOR	D33-334
	AUDIO INTERFACE	D33-336
	BULK DELAY	D33-335
	FUNCTIONAL DIAGRAM (MONITOR)	
	MIXER	D15-12
	DECODER	D33-312
	AVC	D33-328
	METER	D33-329
	POWER SUPPLY	D33-330

LIST OF TABLES

FOREWORD

I. WHAT IS C-QUAM?

C-QUAM is the Compatible Quadrature Amplitude Modulation method of stereo transmission by which a main (L+R) and a subchannel (L-R) signal are transmitted on a single carrier. This is accomplished by using two modulation modes to transmit the main and stereo information channels. Stereo receivers separate the signals to ultimately produce left and right channel audio while typical monophonic receivers detect only the L+R (mono) content of the C-QUAM signal. The most important feature of C-QUAM is that no compromises are made in the monophonic performance in order to transmit stereo. It is truly a compatible stereo transmission system.

II. AM AND PM MODULATION

To ensure a full understanding of C-QUAM a quick presentation of modulation characteristics is in order.

Amplitude modulation is the process in which one signal's amplitude is varied by another signal. An oscilloscope display depicts the amplitude variation versus time of the AM signal. This is the familiar RF envelope display illustrated in Figure 1A. The AM signal can also be described in the frequency domain with an amplitude versus frequency plot. Figure 1B illustrates a typical spectrum analyzer display of an AM signal. The display reveals a carrier and two sidebands separated from the carrier by the modulating frequency. In AM, as the modulation is increased, the sideband amplitudes increase but the average carrier level remains constant.

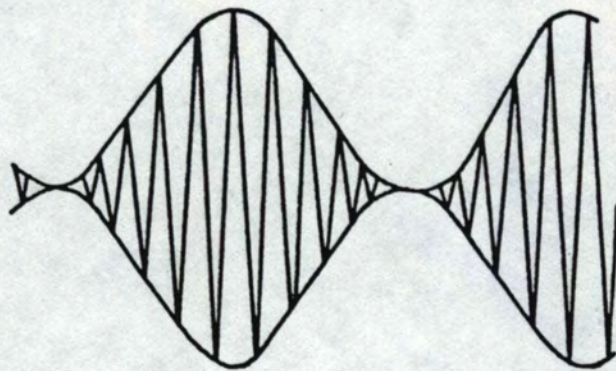

FIGURE 1A
ENVELOPE

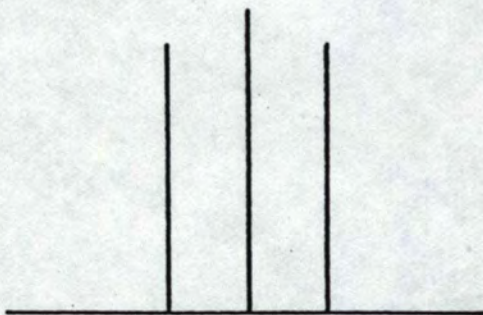

FIGURE 1B
SPECTRUM

FIGURE 1
AMPLITUDE MODULATION

Phase modulation results in very different time and frequency domain plots. PM is generated by varying the phase of the carrier signal, and thus, its frequency, while the amplitude remains constant. Figure 2A illustrates a PM signal RF envelope. The spectrum analyzer plot of a PM signal reveals sidebands spaced at multiples of the modulation frequency from the carrier. Since the amplitude of the PM signal is constant, the phasing of the sidebands is such that they add and subtract to produce a constant amplitude. Figure 2B illustrates the PM signal spectrum plot.

Since the phase of the carrier is not affected by amplitude variations, a phase detector output is zero when an AM signal is input. Similarly, an envelope detector does not detect phase variations of the PM signal. All the sidebands add and subtract according to their phasing to produce a constant amplitude RF signal. Thus, a phase modulated carrier can also be amplitude modulated producing a signal that carries two channels of information easily separated at the receiver. Most important is the fact that neither modulation mode affects the output of the other mode detector. This effect allows C-QUAM to be perfectly compatible with all AM receivers. C-QUAM transmits the L+R (mono) information with AM while the L-R (stereo) information is contained on the PM signal. The millions of existing envelope detector type radios now in use detect only the L+R AM signal, thus producing a clear undistorted mono audio signal that is completely unaffected by the L-R stereo subchannel information sent on the same carrier. Stereo decoders detect the L+R and L-R separately and dematrix them to produce left and right stereo audio.

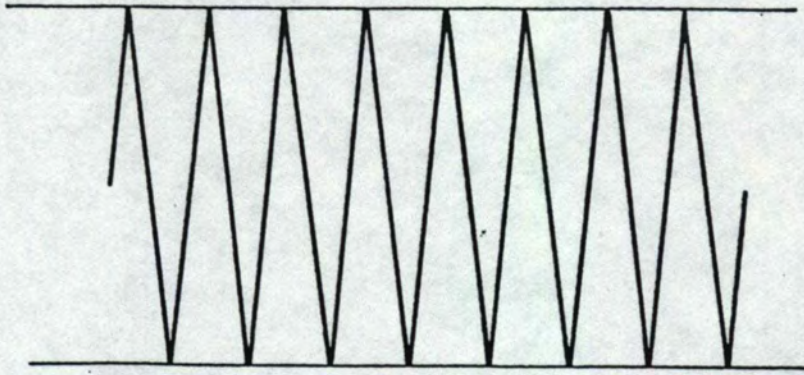

FIGURE 2A
ENVELOPE

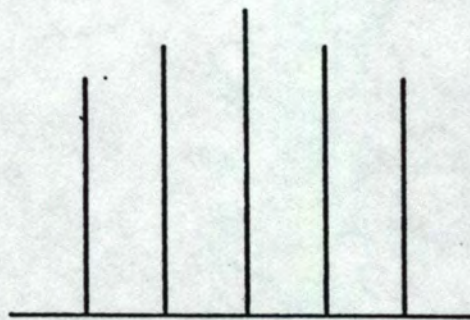

FIGURE 2B
SPECTRUM

FIGURE 2
PHASE MODULATION

III. GENERATING C-QUAM

The AM/PM method of stereo transmission discussed can be achieved by several methodologies. C-QUAM uses the L+R information to produce an in phase, I, AM signal while the L-R information is used to generate a quadrature (90° phase shifted), Q, AM signal. Summing the I and Q signals results in a signal that is both amplitude modulated and phase modulated. This quadrature amplitude modulated (QUAM) signal is not compatible with envelope detector receivers because the Q channel amplitude affects the amplitude of the sum of the I and Q channels. The QUAM signal is thus passed through a limiter to strip off the amplitude variations leaving only a phase modulated carrier. This phase modulated carrier generated from quadrature amplitude modulation replaces the carrier normally generated by the crystal oscillator in the broadcast transmitter. The I information (L+R) can then be used to amplitude modulate the phase modulated carrier in the broadcast transmitter as is done in conventional AM. The output of the transmitter is thus the C-QUAM signal. Figure 3 illustrates the C-QUAM transmission methodology.

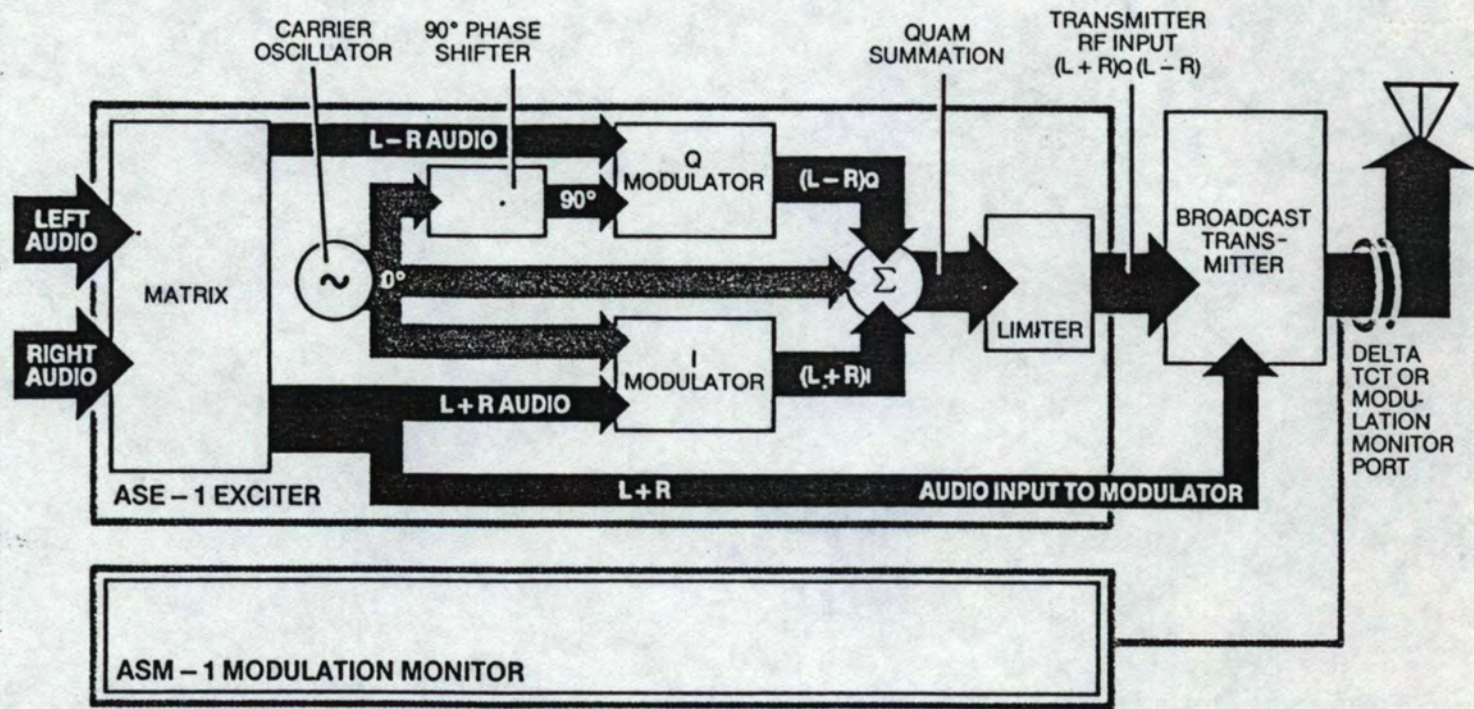

FIGURE 3
C-QUAM BLOCK DIAGRAM

SECTION 1

INTRODUCTION

1.1 SCOPE

This manual describes the installation, adjustment and maintenance of the C-QUAM Stereo System ASE-1/ASM-1 manufactured by Delta Electronics, Inc. The information in this manual is intended for use only by Delta trained or approved Installation Team personnel. Section 2 deals with checkout of newly delivered C-QUAM Stereo equipment. Section 3 instructs measurement of broadcast transmitter performance with the ASM-1. Section 4 discusses the ASE-1/transmitter RF interface. Section 5 describes the required audio connections and adjustments for phasing and equalization. In Section 6, procedures are given for the first Proof of Performance measurement process involving the new equipment. Sections 7 and 8 are Equipment and Assembly level Lists of Material, and Assembly Schematic Diagrams, respectively.

As noted in the accompanying Customer Information, Delta warrants its C-QUAM Stereo products as to material integrity, unit quality and workmanship, excluding component parts purchased from other sources. Also, this Manual is intended for use only by personnel familiar with potentially hazardous electrical/electronic circuitry. It does not contain a complete statement of safety precautions. The information presented is accurate up to Issue Date., but Delta cannot assume liability for technical application of that information, nor for damage or injury resulting from use of the subject C-QUAM Stereo equipment.

1.2 SYSTEM SPECIFICATIONS

1.2.1 System Closed Loop Performance

The following measurements represent typical closed loop performance of the Exciter operating into the Monitor.

Stereo Separation:

35 dB minimum, 100 Hz to 5 kHz

Harmonic Distortion:

L = R monaural 0.25% max., at 85% mod.

Frequency Response:

L,R 50 Hz to 15 kHz +/- 1.0 dB

L = -R pure stereo 0.5% max., at 85% mod.

L, R single channel 1.0% max., at 70% mod.*

*NOTE: This is equivalent of 140% modulation 70% envelope modulation, simultaneous with 70% stereo information.

1.2.2 ASE-1/ASM-1 Unit Specifications

EXCITER

Audio Input:

Right and Left 0-10 dBm
Adjustable, 600 ohms
balanced

Meter Range:

-20 to 3 dB
0 dB = 100% modulation

RF Output:

Adjustable, to 3W (Carrier
frequency) into 50 ohms

Audio to Transmitter (L+R)_I:

Adjustable, to 16 dBm

MONITOR

RF Input:

1-10 volts RMS,
impedance 50 ohms
Frequency crystal controlled

Modulation Meters' Range:

0-140%, -20 to 3 dB
Adjustable, 0 to -50 dB in
-10 dB steps

Accuracy:

+2%, at 100% mod., 400 Hz

1.2.3 ASE-1/ASM-1 Controls and Indicators

EXCITER

Meter Functions:

(L+R)₀ and (L-R)₀ or
LEFT and RIGHT selected by
front panel switch

Also (L+R)_I using (L+R) ENV
Switch under front panel cover

Mode Switches:

STEREO/MONAUURAL
Switch under front panel cover
NIGHT/DAY
Switch under front panel cover

Pilot Tone Switch:

ON/OFF
Switch under front panel cover

LED Indicators:

STEREO, NIGHT, PILOT

Phase Equalization:

Adjustable internally

Exciter Outputs:

BNC connectors, rear panel
High Level carrier frequency,
phase modulated
TTL Level carrier frequency,
phase modulated
Unmodulated carrier frequency
sync output
Sample Transmitter C-QUAM output,
2 volts peak-to-peak into 50
ohms for closed loop tests.

Barrier Strip, rear panel
L+R audio output

MONITOR

Modulation Meters' Functions:

(+) or (-) L and L+R, or
R and L-R
Front panel switch

Peak Modulation Indicators:

(L+R) Group:

-100% indicator internally set to
flash when modulation exceeds -99%
+125% indicator internally set to
flash when modulation exceeds +124%
Peak Indicator adjustable via
wheel switches from 30% to 150%.
Modulation selectable via push-
button switches + or -

(L-R) Group:

Negative limit set internally to
flash at 1.46 radians or 83.67°
(L-R) limit set internally to flash
when modulation exceeds 99%
Peak flasher adjustable via thumb-
wheel switches for 30% to 125%

Monitor Outputs:

BNC connectors, rear panel
Remote Flashers (L+R), (L-R)
Remote Meters (L+R), (L-R)
Right and Left Audio
600 ohms, balanced and unbalanced
(L+R), (L-R) and 25 Hz

DS801 DS802 S801 DS803

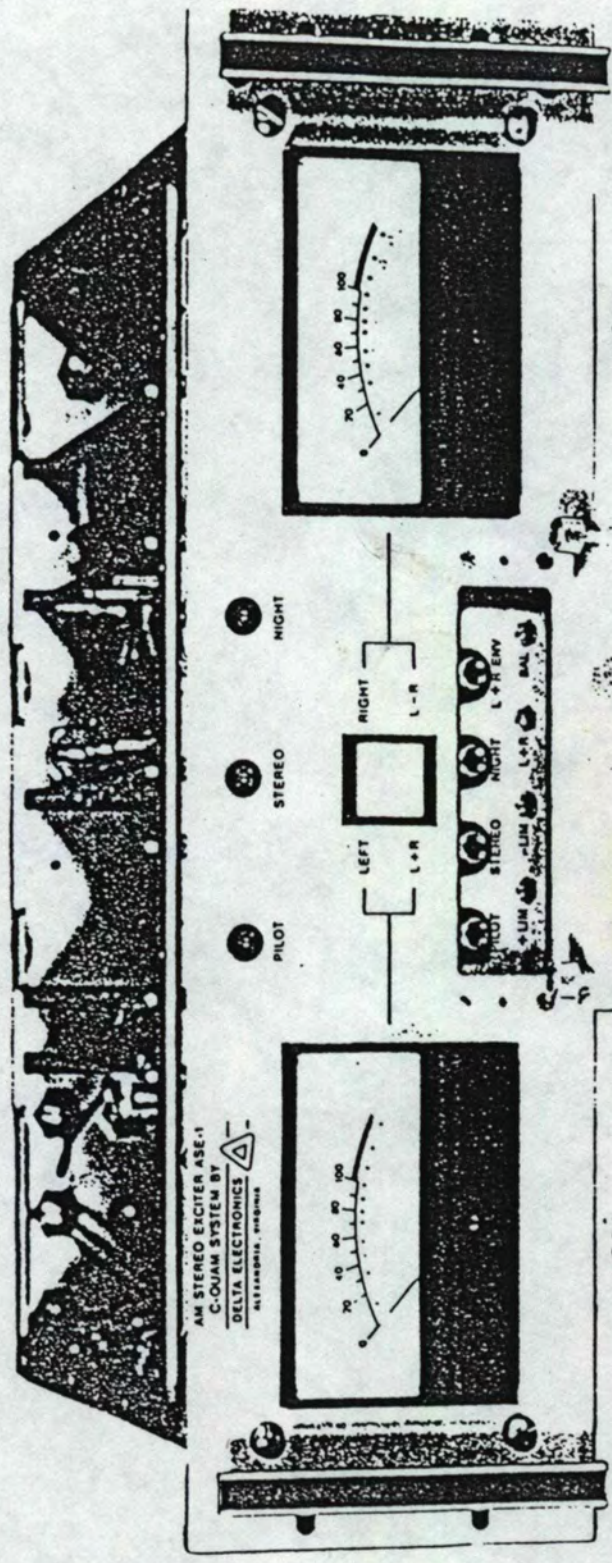

R782 R781 R784 R783
S802 S803 S804 S805
EXCITER FRONT VIEW

1.3 ASE-1 STEREO EXCITER DESCRIPTION

1.3.1 Exciter Front Panel

REF	DESCRIPTION	FUNCTION
M801 M802	Meters	Audio level meters for test/set up Note: the meters are not to be used as an indication of modulation
DS801	Pilot Indicator LED	On/Off indication of pilot output
DS802	Stereo Indicator LED	On/Off indication of stereo operating mode
S801	Function Switch	Top - (L+R _I) set up position indicating the relative level of left and right channel audio drive. Bottom - (L+R _O) indicates L+R and L-R audio drive levels
DS803	Night Indicator LED	On/Off indication of night operating mode
R782	+ Limit	* Audio drive level limiting adjustment
R781	- Limit	* Audio drive level limiting adjustment
R784	L+R Adj	Sets output levels of L+R signal fed to modulation input of station transmitter
S803	Mono/Stereo Switch	Selects between mono and stereo mode
S802	Stereo Pilot Switch	On-Off pilot switch
S805	L+R Envelope Switch	Momentary action pushbutton switch to test if drive to the L+R _I envelope is present
S804	Night/Day Switch	Changes equalization for use with another transmitter or antenna. Works in parallel with remote switch on back. Optional control used only if Exciter is equipped with the night equalization feature.
R783	Balance	Allows slight amplitude adjustment between left and right inputs

* Misadjustment will reduce stereo separation

1.3.2 Exciter Rear Panel

REF	DESCRIPTION	FUNCTION
J2	Sync Out	Sync from encoder to evaluate amount of phase modulation of master carrier frequency
J3	Exciter Output	Square wave output to AM transmitter for high power drive (0.5 to 5.0 watts in steps). This signal is the phase modulated substitute for the transmitters' oscillator.
J1	Sample Transmitter Output	C-QUAM output for test of Exciter to monitor
TB1 1, 2	Remote Night/Day Switch	Works in parallel with front panel switch for changing equalization when using another transmitter or antenna. (See Exciter front panel controls.)
TB2	Audio Input	Left and Right 600 ohm balanced audio input 0 dBm to 10 dBm (determined at time of installation).
TB1 3-6	L+R Output	Balanced output from L+R amplifier to station transmitter (normal AM modulation input). Adjusted by L+R Adj. front panel control, +16 dBm maximum.
J4	TTL Output	Phase modulated signal which is acceptable for TTL compatible transmitters. Substitutes for normal oscillator of station transmitter.

1.3.3 Exciter Circuit Cards - Basic Functions

Power Supply

The Power Supply operates from a 117V AC, 60 Hz source and is protected with a 1.5 amp fuse. It provides (+5), (-15) and (+15) volt DC regulated outputs and -24V DC unregulated for the meter lamps and front panel LEDs.

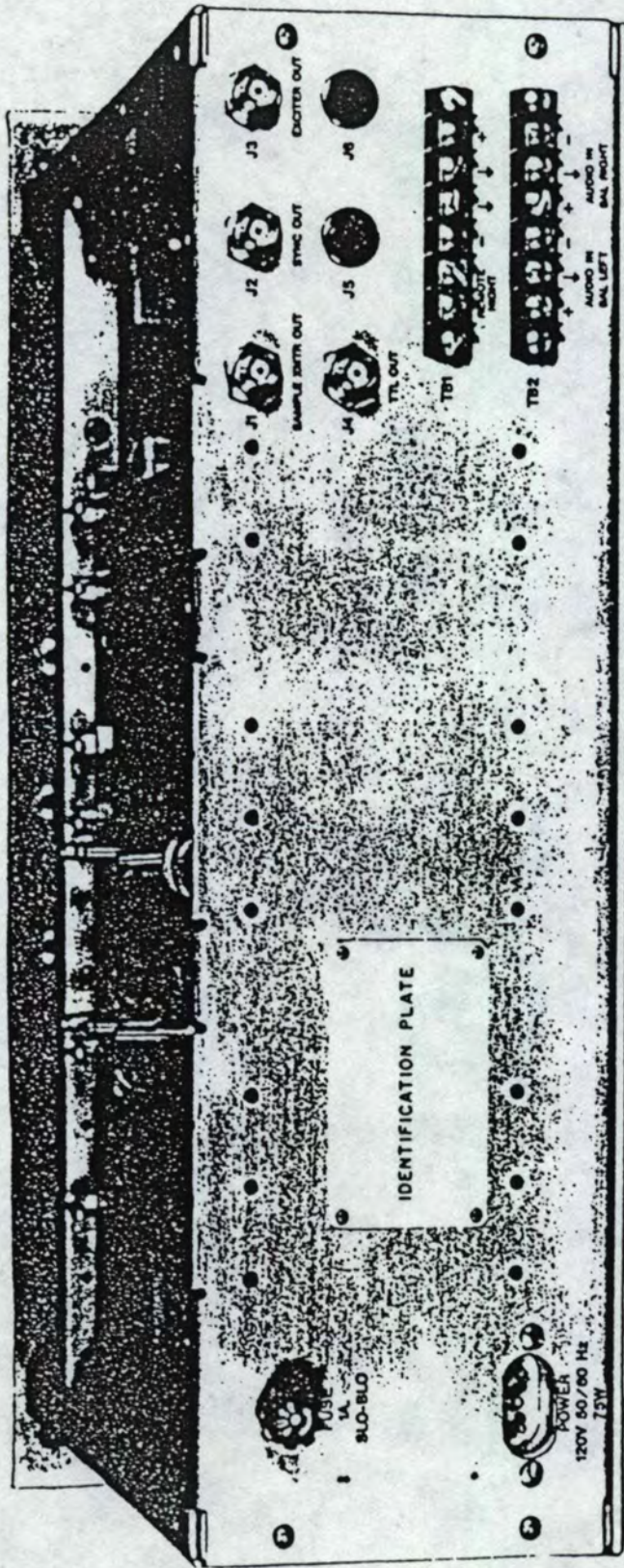

EXCITER REAR VIEW

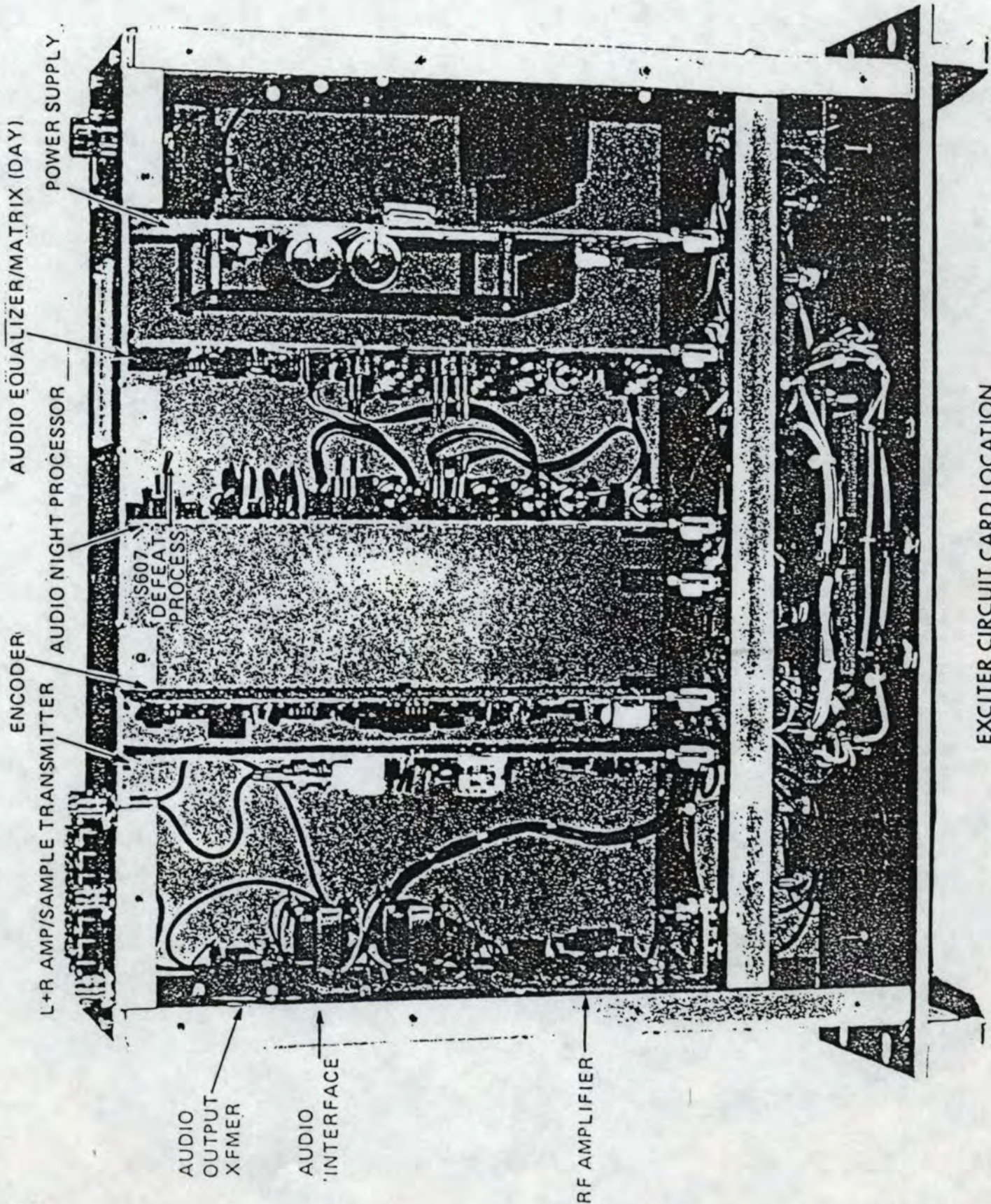

L+R AMP/SAMPLE TRANSMITTER

ENCODER

AUDIO NIGHT PROCESSOR

AUDIO EQUALIZER/MATRIX (DAY)

S607 DEFEAT PROCESS

AUDIO OUTPUT XFMR

AUDIO INTERFACE

RF AMPLIFIER

EXCITER CIRCUIT CARD LOCATION

Audio Equalization Matrix (Day Card)

This unit receives the LEFT and RIGHT audio inputs and passes these signals through the HIGH and LOW FREQUENCY EQUALIZATION sections, compensating for signal path differences in various transmitters. The signals then pass to the audio matrix circuitry that produces the L+R and L-R, I and Q signals. Positive and negative peak limiting of these signals is provided and finally this unit drives the front panel meters that display the relative audio drive levels.

Audio Night Processor (Night Card)

This unit, when the FRONT PANEL SWITCH is in the NIGHT position receives the LEFT and RIGHT audio inputs and passes these signals through the HIGH and LOW FREQUENCY EQUALIZATION sections, compensating for signal path differences in the NIGHT transmitter. LEFT and RIGHT audio signal DELAY from 0 to 15 microseconds is also provided to compensate for both the DAY and NIGHT transmitter signal path delay differences.

A PROCESS circuit to prevent high single channel modulation (LEFT or RIGHT audio signals only) operation is located on this unit.

Encoder

The encoder generates the primary frequency of the station. The carrier is modulated with two signals, (L+R) and (L-R) 90° out of phase. A limiter eliminates the AM component of the QUAM signal. The source for the pilot frequency is located on this card.

L+R Amplifier/Sample Transmitter

The L+R amplifier located on this circuit card generates an output which drives the envelope modulator of the normal station transmitter. It also originates a sample C-QUAM transmitter signal which simulates the full stereo transmitter for the purpose of checking the modulation monitor.

RF Amplifier

The RF amplifier produces a variable high power phase modulated output and a TTL level output which replaces the transmitter master oscillator.

Bulk Delay Card

This unit supplements the LEFT and RIGHT audio signal DELAY of the AUDIO, NIGHT, PROCESSOR (NIGHT CARD) by providing four 8 microsecond delay sections for a total of 32 microseconds of additional delay.

Audio Interface Card

This circuit card mounted on the left side of the EXCITER provides the interconnections for the two 600 ohm attenuator pads that reduce the station's LEFT and RIGHT input audio (typically +10 dBm level for 100% modulation) by 16 dB before the signals reach the balanced input TRANSFORMERS. The (L+R)_I audio signal output transformer is also interconnected on this card.

1.3.4 Exciter Circuit Card Edge Connector Pin Identification

The exciter circuit card has 22 connections on each side of the card, labelled as shown above.

CAUTION

Be sure to reinsert cards oriented in the same position as they were removed.

EDGE CONNECTOR PIN IDENTIFICATION

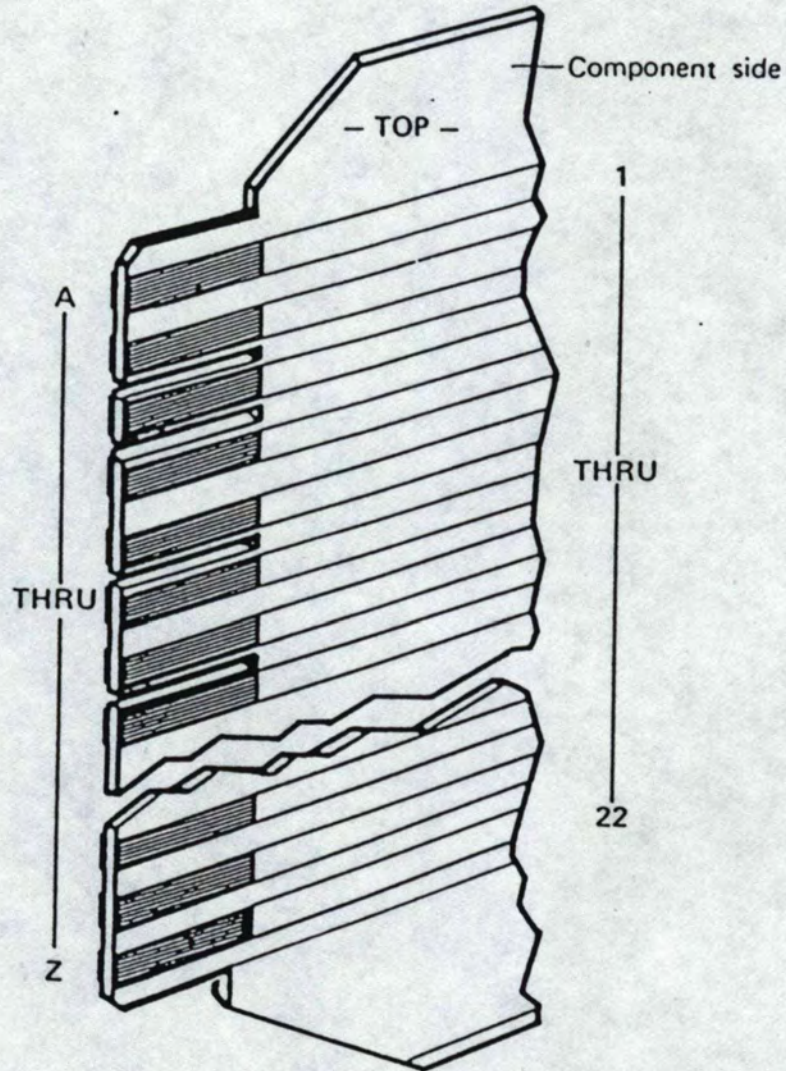

The exciter circuit card has 22 connections on each side of the card. When viewed as shown above, the alphabetical pin outs are always on the left and the numerical are on the right.

-- CAUTION --

Be sure to reinsert cards oriented in the same position as they were removed.

1.4 ASM-1 MODULATION MONITOR DESCRIPTION

1.4.1 Modulation Monitor Front Panel

REF	DESCRIPTION	FUNCTION
M801 M802	Meters	Modulation meters for test and set up
S801	Meter Range Switches	Left channel meter range selection switches
S802	Meter Range Switches	Right channel meter range selection switches
S801	Left Channel Modulation Function Switch	Switches peak flasher DS803 and left meter between (L+R), (L), (+) or (-) functions
DS803 DS804	(L+R) Flashers and Controls	The (L+R) peak flasher modulation range is set via the front thumb wheel switch. Its function depends on the modulation switch setting S801. The monaural (-100%) envelope and (+125%) envelope limits have no external settings and are both fixed factory adjustments. Peak amplitude can be accurately determined by increasing the reading on the thumb wheel until the light goes out. The number on the thumb wheel will be the peak modulation.
S802	Right Channel Modulation Function Switch	Switches peak flasher S804 and right meter between (L-R), (R), (+) or (-) functions.
DS804 DS805	(L-R) Flashers and Controls	The (L-R) peak flasher modulation range is set via the front thumb wheel switch. Its function depends on the modulation switch setting S802. The (L-R limit) and (neg limit) have no external setting and are both fixed factory adjustments.
DS804 DS805	(L-R) Flashers and Controls (Continued)	The (L-R limit) is equivalent of a 100% phase modulation signal. The (neg limit) indicates that the L-R component is overmodulating the combined modulation envelope. Peak amplitude can be accurately determined by increasing the

MONITOR FRONT PANEL

reading on the thumb wheel until the light goes out. The number on the thumb wheel will be the peak modulation.

DS807 Pilot Tone Indicator Indicates presence of 25 Hz pilot tone

M803 Carrier Level Meter Establishes a carrier reference level necessary to insure that the circuits driving the modulation meters are affected only by modulation changes. The carrier level meter indicates the average RF signal level input to the monitor decoder circuits. The RF signal input is set to a level (indicated on the meter and determined by the manufacturer) by means of the carrier set control R819. As long as the carrier level indication is within the range of the meter (+/-20% change of RF level), the modulation circuits will be within their design accuracy.

S803 Switch Two position meter function switch. In the pilot tone position, the carrier meter must indicate in the black square (pilot) position. This is a fixed factory adjustment which does not have an external setting.

In the carrier set position, the meter must indicate in the center on SET. The set position can be adjusted with the (carrier set) and rear panel (RF attenuator) controls.

R819 Carrier Set Control Vernier control which operates in conjunction with the 60 dB RF step attenuator on the back panel.

1.4.2 Modulation Monitor Rear Panel

REF	DESCRIPTION	FUNCTION
J2	Remote Modulation Meter L+R	DC drive current for remote panel meter operation
J1	Remote Peak Flasher L+R	Drive signal for remote operation of flasher

MONITOR REAR PANEL

J3	Remote Peak Flasher L-R	Drive signal for remote operation of flasher
J5	Envelope Detector	Test output to evaluate monitor decoder
J7	L-R Detector	L-R (quadrature) detector test output to evaluate monitor decoder
J9	Unbalanced Output Left	For distortion measurements of left audio channel
J11	Unbalanced Output Right	For distortion measurements of right audio channel
S803 (A3)	RF Attenuator	A 60 dB step attenuator in 10 dB steps used with the front panel carrier set control to calibrate the monitor
J13	RF Input	RF sample input from transmitter
J12	L-R	L-R output for evaluation of stereo signal
J10	L+R	L+R (mono) output for evaluation of monaural signal
J8	In Phase Detector (I Det)	Test output to evaluate monitor decoder operation
J6	Pilot Tone Output	Counter connection for measurement of pilot frequency
TB1	600 Balanced	Balanced 600 ohm audio output
J4	Remote Modulation Meter L-R	DC drive current for remote panel meter operation

1.4.3 Monitor Circuit Cards - Basic Functions

Power Supply

The power supply operates from a 110V AC source and is protected with a 2 amp fuse. It provides (+5), (-15), and (+15) volt DC outputs, and the 28 volts for the modulation meter lamps.

MONITOR
CIRCUIT CARD LOCATIONS

Meter

This circuit card contains the audio amplifiers and peak detectors which drive the DC meters. Additionally, it provides the circuitry to drive both right and left peak flashers operating in conjunction with the front panel mounted thumb wheels. It also provides the audio matrix of balanced and unbalanced outputs to the rear cabinet ports. Pilot reject filters are included on this circuit card which eliminate the 25 Hz pilot tone from the meters when making measurements of the left or right channel.

AVC

The AVC circuit card controls the audio signal level allowing the audio signal to be used as an instantaneous indication of the modulation level. This card also contains the carrier level detector and carrier meter drive circuitry, along with the pilot detector and meter drive circuits. With the exception of the two peak flashers, the five remaining flasher drivers are on the AVC panel:

1. +125% envelope limit
2. -100% envelope
3. L-R limit (measures recovered audio)
4. Neg limit (combined overmodulation indicator)
5. Pilot tone indicator

Decoder

The decoder receives 450 KHz from the mixer circuit card, then detects and separates the envelope and (L-R)_Q signals which are sent to the AVC card. For test purposes, it provides three detected outputs to rear

cabinet ports:

1. Envelope detector output
2. In-phase detector
3. L-R quadrature detector

Mixer

The station RF signal is input to this circuit for conversion to a 450 kHz IF. It has a wide band front end which is switch programmed to the station frequency at the factory.

1.4.4 Monitor Circuit Card Edge Connector Pin Identification

The Monitor circuit card has 22 connectors on each side of the card, labelled as shown above.

NOTE: The card pin outs are keyed to the socket.

CAUTION

Be sure to reinsert cards oriented in the same position as they were removed.

CARD EDGE CONNECTOR
PIN IDENTIFICATION

SECTION 2

EQUIPMENT CHECKOUT AND INITIAL TESTS

2.1 CHASSIS INSPECTION

The shipping cartons for the Exciter and Monitor are designed to protect the equipment for normal handling during shipment. Thoroughly inspect the equipment for any evidence of mishandling. Report damage to the carrier immediately.

2.2 MECHANICAL CHECKOUT

CAUTION

Complete this procedure before applying power to units.

Remove all screws from the top panels of the Exciter and the Monitor. Open the card sockets by operating the cam levers. Reseat each board by firmly pressing down on the board while closing the socket using the cam lever.

After reseating all circuit cards, secure the top covers to the Monitor and Exciter.

2.3 REQUIRED TEST EQUIPMENT

Low distortion oscillator, 600 ohms output, +10 dBm, less than 0.1% distortion.

Distortion analyzer, capable of indicating distortion levels of less than 0.1% distortion.

Oscilloscope, bandwidth 10 MHz or better, capable of X-Y display of audio frequencies with no appreciable phase shift.

Spectrum analyzer, frequency range covering the AM broadcast band, better than 60 dB logarithmic scale, and a resolution of better than 300 Hz.

Use of Stereophonic X-Y Oscilloscope Display

Use an oscilloscope continually in an X-Y mode to display the stereophonic operation of the C-QUAM Exciter and Monitor. An adequate X-Y display requires an oscilloscope of such sensitivity, bandwidth and phase characteristics that both the horizontal and vertical axes display audio signals of approximately 0.5 volts peak to peak with no appreciable phase shifting. The X-Y display is very useful in troubleshooting and adjusting AM stereo equipment. It can indicate the amount and nature of incidental phase modulation, audio displays or phase shifts, operation of audio processing equipment, amount of stereo in programming and display many other system characteristics, in keeping with the expertise of the observer.

Figure 5 shows the ideal displays of sine wave modulation under the indicated modes of stereo operation. Additional sample X-Y displays are shown in Figures 6 and 7.

Referring to Figure 1 on Page 2-4, connect the oscilloscope to the Monitor unbalanced left and right BNC outputs J9 and J11. Connect the left output to the X axis oscilloscope input.

CAUTION

Reduce the intensity of the oscilloscope during extended periods of zero modulation as the trace will consist of a single dot which could burn the phosphor of the cathode ray tube.

Figure 5.

Ideal Oscilloscope Displays of Stereo Signals

Figures 6 & 7.

Sample Oscilloscope Displays of Stereo Signals

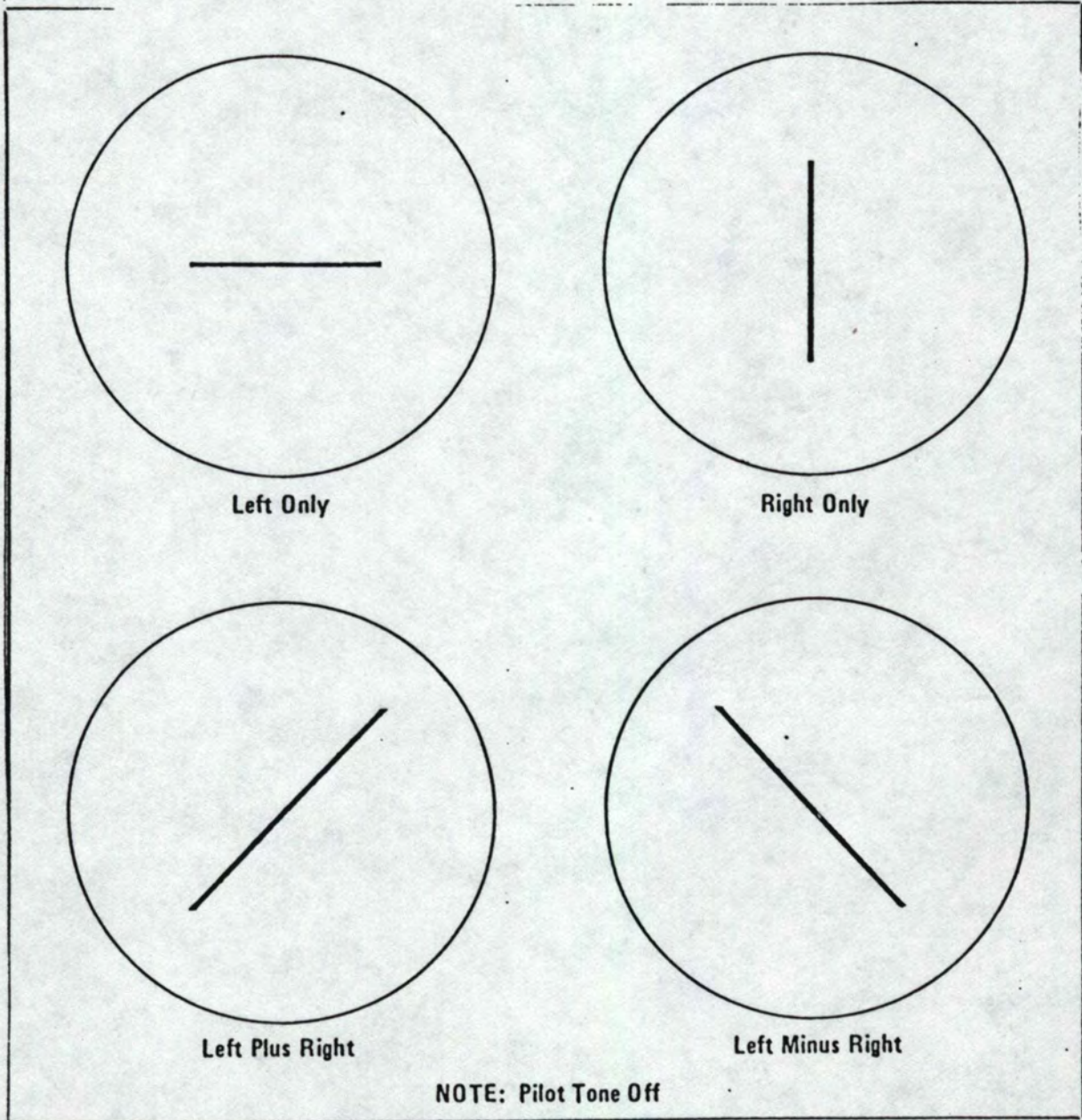

Figure 5. Ideal Oscilloscope Displays of Stereo Signals

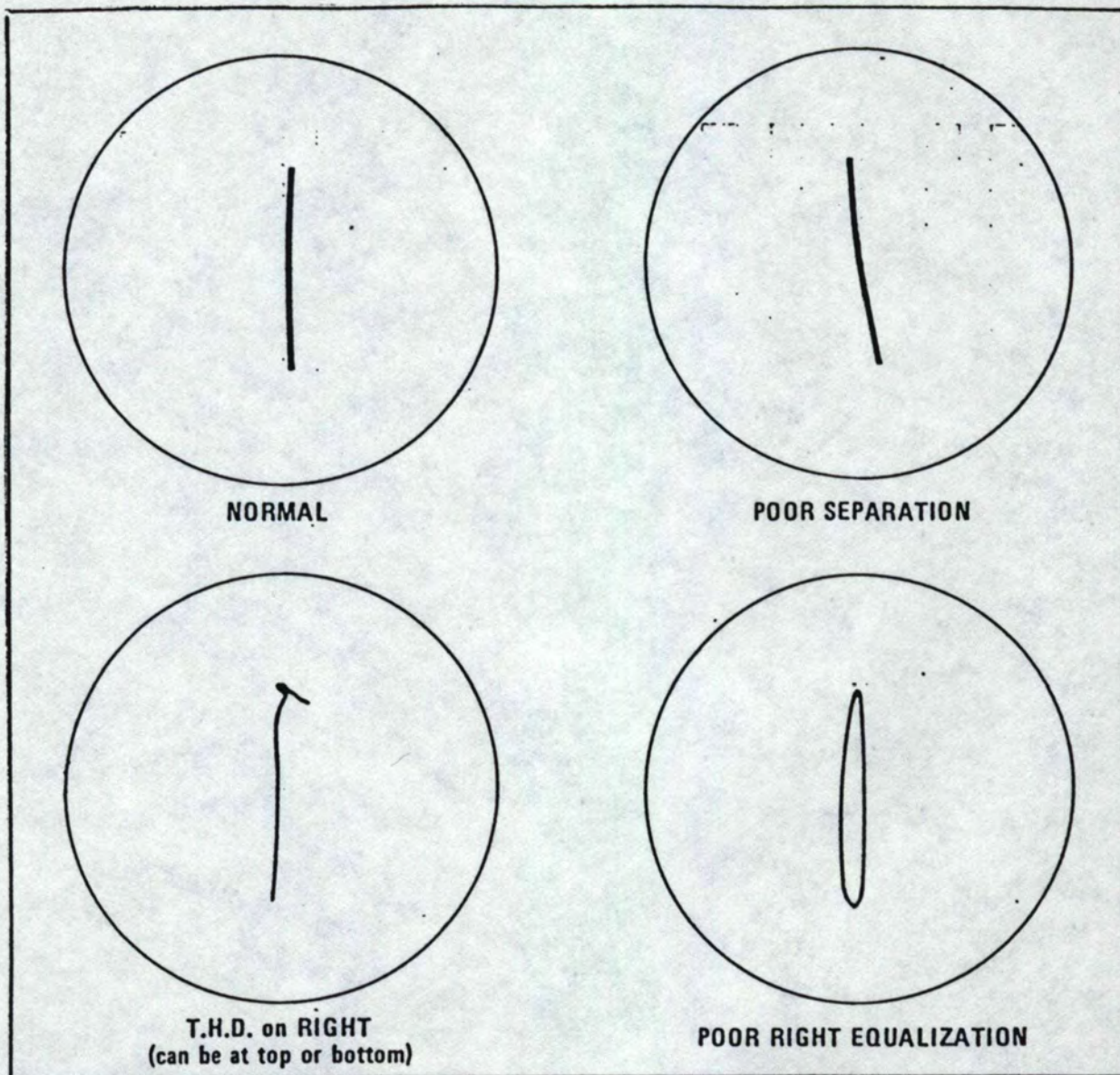

Figure 6. Sample Oscilloscope Displays of Stereo Signals

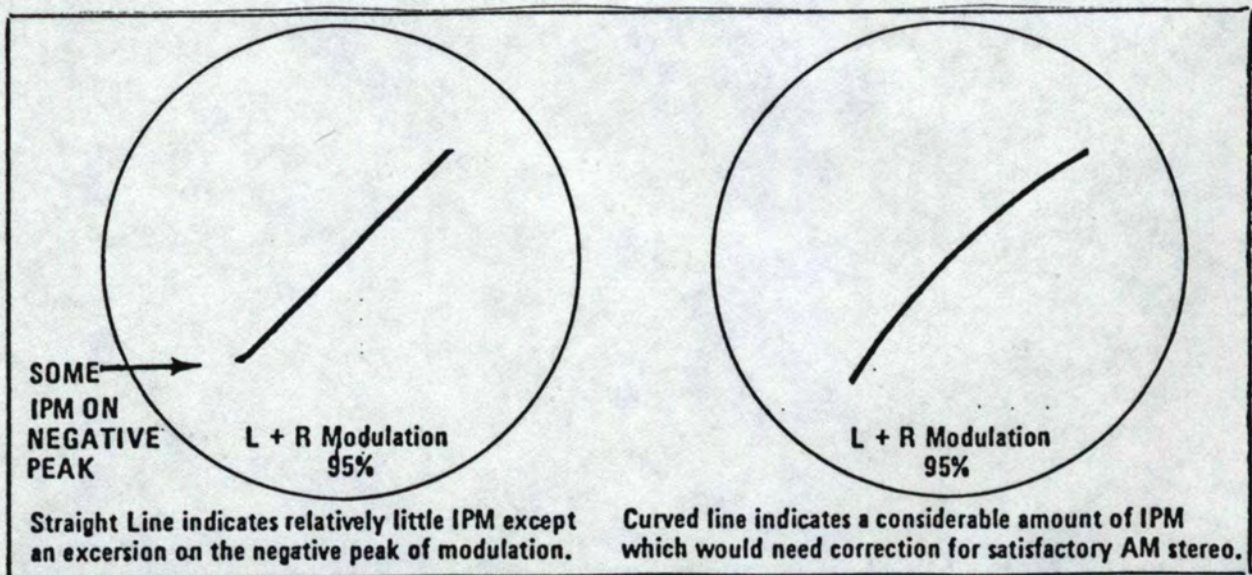

Figure 7

2.4 CLOSED LOOP TESTS

2.4.1 Connections

Connect the distortion analyzer, oscilloscope and spectrum analyzer to the Exciter and Monitor as shown below in Figure 1.

Figure 1. Closed Loop Equipment Arrangement

Fifty ohms is the usual input impedance to the spectrum analyzer, the input impedance of the Monitor, and the output of the Exciter sample transmitter. Therefore, use a matching pad of approximately 17 ohms in each leg for proper termination. The oscilloscope input can be paralleled with the spectrum analyzer input because the oscilloscope input is usually high impedance. The distortion analyzer input, which will be used to take measurements from several of the Monitor rear panel outputs via BNC connectors, also can be unbalanced.

Connect the audio oscillator to the 600 ohm, unbalanced Exciter input terminals. The following test input modes are required: left only (L), right only (R), left plus right (L+R), and left minus right (L-R). In the L or R function, the audio oscillator (balanced or unbalanced) can be directly connected to the input terminals. For L+R or L-R, the Exciter audio inputs are paralleled either in phase, or out of phase. In either case, the input impedance of the paralleled inputs is 300 ohms. Although it is usually not necessary with high quality audio oscillators, a matching pad can be constructed as follows.

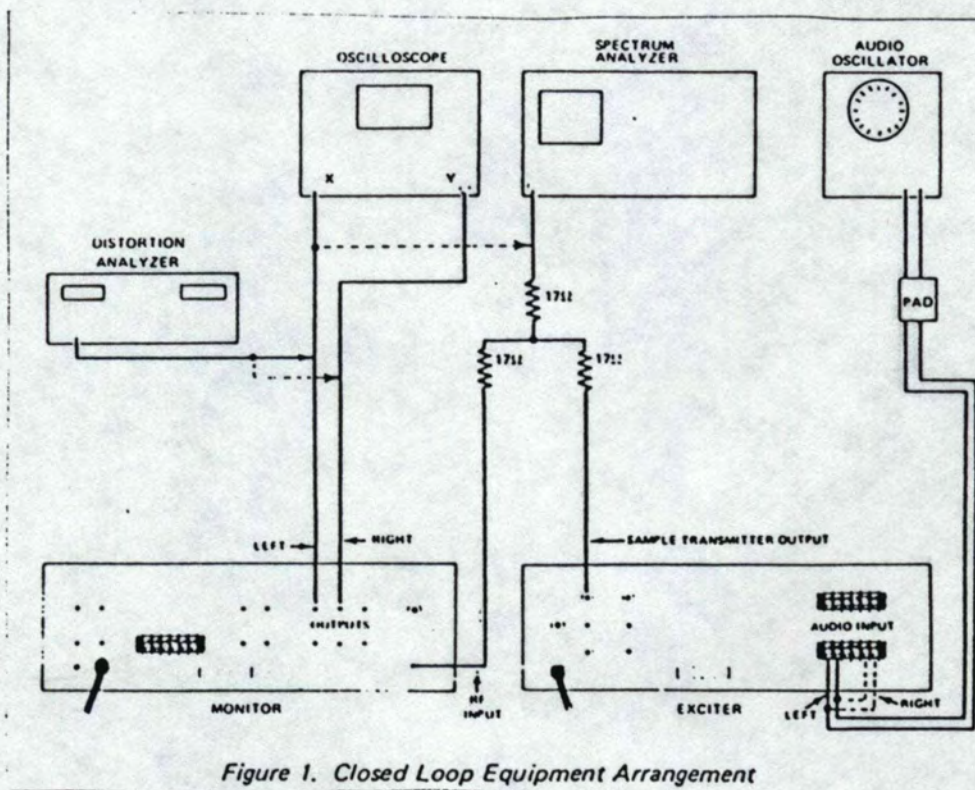

Figure 2

Some oscillators already contain the switching and matching for the four modes of operation. These features simplify testing.

Connect the Sample Transmitter Output to the Monitor RF Input with a BNC to BNC coaxial cable. Apply AC power to the Exciter and the Monitor by plugging in the line cords to a suitable AC outlet.

NOTE

There is no power switch for either the Exciter or the Monitor. Therefore, unplug the line cords to turn either unit off.

After AC power is applied, the lights for all meters should be lighted. Throw the meter switch (small toggle switch on the Monitor under the Carrier Level meter to Carrier position).

Adjust the appropriate RF input level to the monitor using the step attenuator which is controlled by a rotary switch on the rear of the monitor and the potentiometer front panel control. Observe the carrier level meter while adjusting the input level using the front panel knob. The time constant for the meter circuitry is very long, so wait about 10 seconds after adjusting the knob to determine if the adjustment is within range of

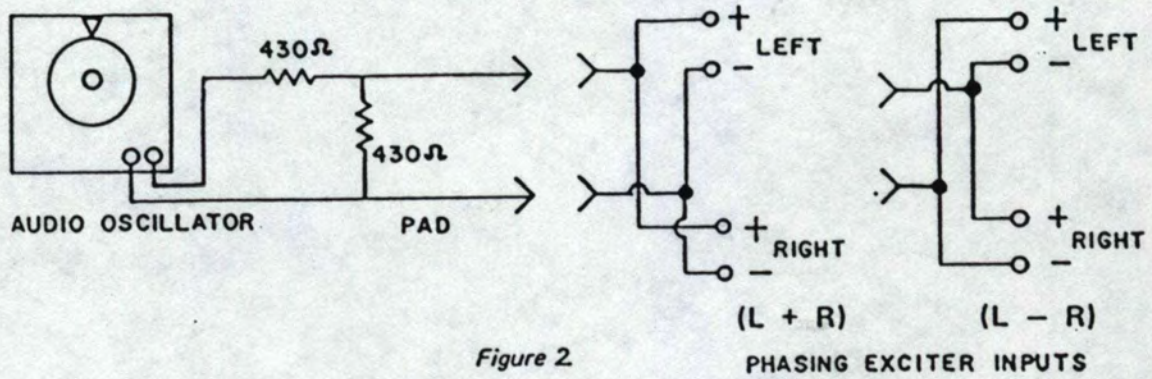

Figure 2

the front panel control. If not, reset the switch attenuator and readjust the front panel control for a center indication on the carrier meter.

With no audio input to the Exciter, the noise level indicated on the Monitor should be lower than 50 dB for L+R and -40 dB for L-R. Select on the Monitor front panel L+R, for the left meter M801, and L-R, for the right-hand meter M802. For each meter there is a row of pushbuttons providing meter ranges in 10 dB steps. Add together the pushbutton selection and the meter indication on the red dB scale for a measurement referenced to 100% modulation.

2.4.2 Left Plus Right (AM) Operation

Connect the output of the audio oscillator through the pad to the left and right audio input terminals of the Exciter, phasing the inputs for L+R operation. Using the monitor left-hand meter control buttons S801 select (-) and (L+R). Set the oscillator frequency to 1 kHz and advance the audio level from the audio oscillator until the meter reads 100 percent modulation. Observe both the oscilloscope display of envelope modulation, and the spectrum analyzer (connected at the exciter sample transmitter output). If the range of the instruments are set properly, the displays should appear as follows:

Figure 3

At 100 percent negative modulation, the oscilloscope envelope pattern should just pinch off to zero signal and the first order sidebands on the spectrum analyzer display should be exactly 6 dB down from the

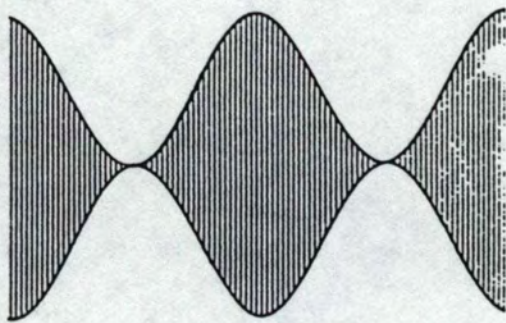

Oscilloscope Envelope

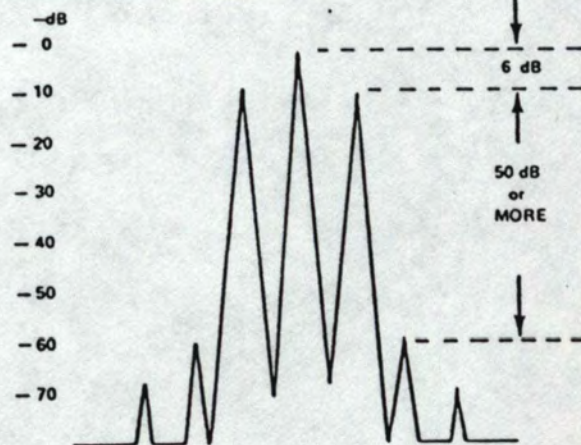

Spectrum Analyzer

Figure 3.

carrier. The high order sidebands on the spectrum analyzer should be at least 50 dB below the fundamental sidebands indicating AM distortion less than 0.3 percent. Set the oscillator level with care because if the modulation even slightly exceeds 100% negative, the high order distortion sidebands will increase very rapidly.

After finding the 100% negative point from the test instruments, observe the monitor modulation meter indication and flasher lights. The 100% negative light should be illuminated and the left-hand panel meter should indicate 100% modulation. Adjust the digital switch immediately to the left of the meter to 100%, and the corresponding LED indicator should also light.

For distortion measurements on L+R, 95% modulation should be used to prevent erroneous distortion measurements which can result from inadvertent overmodulation. Reduce slightly the oscillator level until 95% modulation is shown on the meter. Connect the distortion analyzer to the Monitor rear panel L+R BNC connector J10.

A series of audio measurements now can be made to determine if the system closed loop performance is within specifications. Generally the performance levels should be at least as follows:

Frequency response:	+/-1.0 dB from 30 Hz to 10 kHz
Distortion:	Less than 0.3%
Noise:	Lower than 60 dB below 100% modulation

2.4.3 Main to Subchannel Crosstalk (L+R to L-R Crosstalk)

The isolation between the normal amplitude modulation and the added stereo information will have a direct bearing on the separation obtainable between the left and right stereo channels. Make closed loop measurements to confirm that the Exciter to Monitor operation is capable of transmitting and indicating sufficient isolation.

The transmitted signal is the same as that evaluated in the L+R (AM) measurements described above. However, instead of looking at the L+R Monitor output, measure the residual signal in the L-R detector.

First turn off the pilot tone. Modulate the Exciter with 95% L+R with a 1 kHz tone and observe the right-hand meter. Select the L-R function with the pushbuttons S802 and push the range selector buttons until a reading is obtained. On the Exciter, adjust balance control R783 until a null in the monitor L-R indicator is obtained. Readjust the oscillator output for 95% amplitude (L+R) modulation.

The main to subchannel crosstalk can now be measured over the audio frequency range. The measurements should be within the following specifications:

Crosstalk, L+R to L-R: 35 dB from 20 Hz to 5 kHz
 25 dB from 20 Hz to 10 kHz

The residual signal which appears in the L-R channel can result from the limitations in the modulation monitor but under normal broadcast transmitter operation the first limitation is likely to be the incidental phase modulation (IPM) of the transmitter. When the AM transmitter is modulated, not only is the RF amplitude modulated, but there is a small amount of phase modulation, especially at higher negative levels of

modulation. The Monitor/readings of L-R modulation will be used later to adjust the transmitter for minimum incidental phase modulation, or more accurately, for the C-QUAM System, minimum incidental quadrature modulation.

2.4.4 Subchannel (L-R) Performance Fidelity

Turn off the 25 Hz pilot using the pushbutton located on the front panel of the Exciter. Set up the Exciter with a 1 kHz tone set to 95% amplitude modulation (L+R). Reverse the polarity of one of the inputs to the Exciter which switches the modulation to 95% L-R modulation. Observe the monitor right-hand meter and set the selector pushbutton S802 to "L-R". The meter should read within a percent of 95%. Connect the distortion and noise meter to the BNC connector in the rear of the Monitor labeled "L-R". Fidelity measurements should show performance within the following specification:

Frequency response:	+/-1.0 dB from 30 Hz to 10 kHz
Distortion:	Less than 0.3%
Noise:	Lower than 50 dB below 100% modulation

2.4.5 Subchannel (L-R) Crosstalk Performance

In addition to the fidelity assessment, the "crosstalk" or L-R into L+R should be measured. Use the Exciter audio input connections as above but connect the distortion meter to the Monitor rear panel L+R BNC connector. Set the right front panel meter to L+R and read the crosstalk measurements directly from the modulation monitor.

2.4.6 Subchannel (IAM) Incidental Amplitude Modulation

The L-R into L+R crosstalk minimum performance should exceed the value shown in Figure 8, page

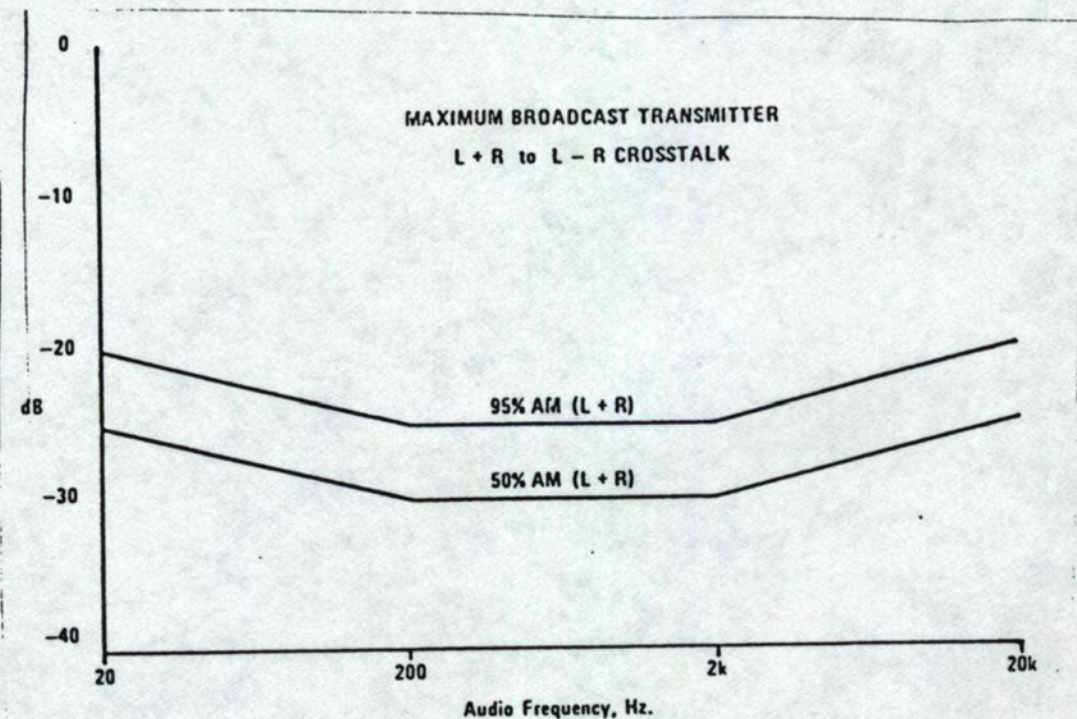

Figure 8

2.4.7 Single Channel Performance

Connect the audio oscillator to the Exciter left channel input and adjust a 1 kHz tone to 50% modulation. The Monitor indication of 50% modulation should be shown on the left meter in the L+R and Left positions. Switch the left-hand meter on the Monitor from reading L+R to Left with pushbuttons S801. Likewise, switch the right-hand meter from reading L-R to Right channel output using pushbutton S802. The separation for 100% modulation can be read directly on the right meter by selecting the appropriate scale with pushbuttons S802.

NOTE

For 50% modulation, the reference (on the dB scale) is 6 dB lower, therefore the separation will be 6 dB less than that indicated. This would be called the left into right separation. Connecting the oscillator to the right channel and reading the residual into the left channel would be the right into left separation.

The separation between the two channels should meet the following specification left into right, and right into left.

Separation : 200 Hz and 5 kHz - 30 dB
30 Hz and 15 kHz - 15 dB

SECTION 3

MONITOR MEASUREMENTS OF BROADCAST TRANSMITTER

3.1 INTRODUCTION

Before attempting stereophonic operation with the broadcast transmitter, connect the ASM-1 Monitor to a broadcast transmitter RF sample so that hum, noise, phase modulation and incidental phase modulation can be measured.

3.2 PROCEDURES

The Monitor can be calibrated on input RF levels from 300 mV to 10 volts RMS unmodulated. A 10 dB per step attenuator is controlled by a knob at the rear of the Monitor, and the fine adjustment is made with a knob on the front panel. Using an unmodulated transmitter, set the monitor RF input level for a center indication on the carrier meter.

Modulate the broadcast transmitter with a 1 kHz tone inserted at the normal audio input terminals. The ASM-1 Monitor simultaneously monitors the normal AM on the meter M801 with pushbutton S801 set to L+R) and the incidental phase (or quadrature) modulation on the meter M802 with pushbutton S802 set to L-R.

Although most AM broadcast transmitters can easily meet the FCC AM noise specification of 45 dB down and many can make more than 60 dB down, the transmitter phase hum can be very different. Power supply PM hum and residual phase noise can originate in the transmitter and be completely harmless for AM operation, but can become very troublesome for stereo broadcasting.

After calibrating the ASM-1 Monitor for the correct RF input level, terminate the audio input to the transmitter and measure the L-R modulation level. It is useful to look at the audio output of the L-R channel with a conventional display on the oscilloscope to determine the waveform of the residual noise. Trigger the scope with a line signal to observe if hum components are primary to the residual signal.

Generally, residual L-R noise should be at least 40 dB below 100% L-R modulation. If this condition is not satisfied, work on the transmitter will be required to reduce the noise level. Improved power supply filtering on the lower level RF stages in the transmitter is a general practice. The dressing of leads having AC currents also may be an issue. The transmitter manufacturer may have experience with or be willing to help solve the PM hum problems.

While modulating the transmitter with a 1 kHz tone at 25, 50, 75 and 95% AM, measure L-R. This information can be dynamically read on an oscilloscope X-Y display which could look like the simulated displays shown below.

Figure 7

Vary the audio modulating frequency, and measure the crosstalk attributable to IPM. Generally, for at least 25 dB of separation under typical stereo program modulation, the measured L+R to L-R crosstalk should be less than that indicated in Figure 8.

Figure 8

Incidental phase modulation sources in AM broadcast transmitters vary considerably. However, two frequent sources are 1) the final amplifier tuning and 2) the final amplifier neutralization. In conventional AM broadcasting, neither adjustment is critical. However, in AM stereo broadcasting, these adjustments can have a substantial IPM effect. If the transmitter IPM measurements do not satisfy the values indicated in Figure 8, or to improve on existing performance, modulate the transmitter with a higher frequency audio tone (5 or 7.5 kHz). Watch the crosstalk in the L-R channel on the Monitor while tuning and loading are adjusted. Neutralization adjustment may involve turning the transmitter plate voltage off then putting the transmitter back on for a measurement.

Again, keep in mind that many transmitter manufacturers now have some experience in AM stereo. It would be advisable to discuss the measurements and crosstalk performance of a particular transmitter with the manufacturer.

SECTION 4

ASE-1 RF CONNECTIONS TO BROADCAST TRANSMITTER

4.1 INTRODUCTION

The C-QUAM AM Stereo Exciter includes several RF outputs designed to interface with most, if not all, existing AM broadcast transmitters. One is a TTL level output designed to drive standard digital circuitry. The other is the output of a 5 watt square wave amplifier which is used to drive a lower level RF stage in the transmitter. This amplifier can be internally programmed for lower output levels if required. Both of these outputs have no amplitude modulation, but do have the proper phase modulation required for C-QUAM AM Stereo. Another output is available at the rear of the Exciter which is not modulated in either amplitude or phase. This output is provided to trigger an oscilloscope for observations of phase modulation, or can be used to drive frequency measurement equipment.

4.2 DISCUSSION

The C-QUAM Exciter will be preadjusted to the station frequency and all RF outputs of the Exciter are on the station's carrier frequency. The oscillator in the Exciter is designed to hold the station frequency well within the FCC specification over a temperature range from 0 to 50 degrees centigrade. Generally, the output should stay within a few Hertz of the assigned frequency.

If the transmitter has a TTL input, then the TTL output of the Exciter is to be connected to the transmitter digital circuitry at a point where it is operating on the station frequency. Some transmitters now use higher frequency crystals which are divided down to the operating frequency. The input is to be made after the division.

Many transmitters, however, will be best interfaced by taking the 5 watt exciter output and applying it to the highest level RF stage in the transmitter which can be fully driven. It is possible for the transmitter output signal to be coupled back through the Exciter and the connecting cables which in turn can cause incidental phase modulation. Therefore, the higher the level on the cable and the higher the RF stage in the transmitter being driven, the less opportunity for incidental phase modulation.

The 5 watt amplifier in the Exciter has a square wave output with a level of approximately 42 volts peak to peak into 50 ohms resistive. The lower level RF stages in the transmitter should be studied to determine where is the best point for inserting drive of this voltage level. If the instruction book for the transmitter does not indicate the normal RF levels, they can be measured with a suitable RF voltmeter or the manufacturer can be consulted.

If a transistor is to be driven, it is recommended initially that the connecting circuitry be as shown below.

Figure 9

If more current is required to pull up the base of the transistor, the values of the "T" pad can be changed.

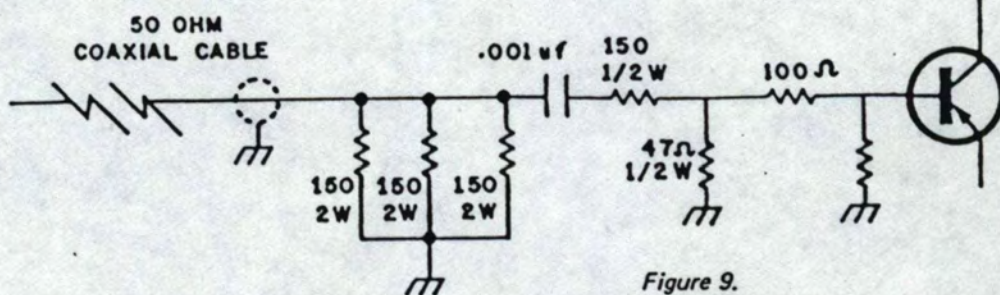

Figure 9.

In the case of driving a tube RF stage, the 50 ohm impedance can be stepped up by tapping down on a coil in the grid circuit of the stage if it is tuned, or by using a toroidal step up transformer.

Figure 10

After sufficient drive from the stereo Exciter to your transmitter has been accomplished, a recheck of the phase modulated hum and noise, and incidental phase modulation should be made. Using the normal audio input to the transmitter, checks should be made of the L-R noise level and crosstalk between AM (L+R) and L-R channels as was previously done. It is also advisable to check the audio performance of the L-R channel to be sure that the broadcast transmitter is not substantially degrading the L-R performance.

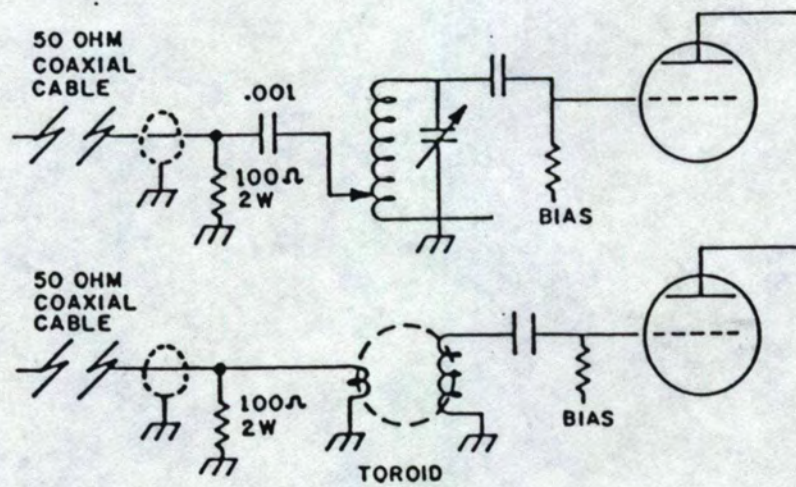

Figure 10

SECTION 5

ASE-1 AUDIO CONNECTIONS TO BROADCAST TRANSMITTER

5.1 INTRODUCTION

The C-QUAM AM Stereo Exciter simply takes the left and right audio channels and sums them into L+R for the broadcast transmitter audio input. Two basic objectives must be met in connections to the transmitter. One is the phasing of the transmitter audio input, and two the input level must be precisely adjusted so that the C-QUAM modulation will be transmitted properly. The audio frequency response and distortion of the circuitry is sufficiently low that it should not affect the monaural performance of the transmitter. Initially, an audio oscillator set to 1 kHz should be connected to the left and right audio inputs of the stereo exciter, phased for L+R modulation.

5.2 PHASING ASE-1 OUTPUT TO THE TRANSMITTER

The phasing of the Exciter audio output to the broadcast transmitter can be checked by comparing the envelope display of the Exciter sample transmitter output with the broadcast transmitter envelope. This should be done with a dual trace oscilloscope in the chop mode with the triggering taken from the audio oscillator (see Figure 11)

Figure 11.

Phasing of Broadcast Transmitter Audio Input

While observing the dual trace display of envelope modulation J1 the depth of modulation can also be approximately adjusted. Start by adjusting the tone to the Exciter left plus right channels from the

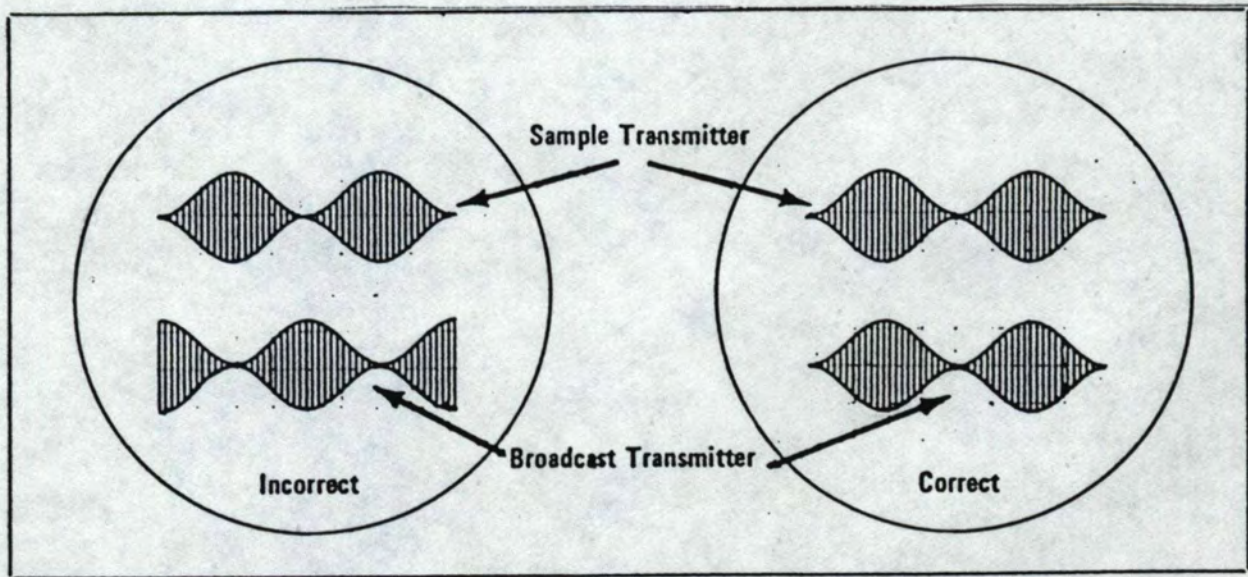

Figure 11 Phasing of Broadcast Transmitter
Audio Input

oscillator until the broadcast transmitter is modulating about 50%. Next, adjust the Exciter audio drive to the broadcast transmitter using the front panel L+R potentiometer until the envelope modulation is the same as the sample transmitter. Increase the audio input to the Exciter until the sample transmitter modulation is 100%, and then adjust the broadcast transmitter modulation to the same value with the front panel screwdriver adjust.

The precise setting of the L+R drive to the broadcast transmitter can be more accurately set by observing separation. However, separation at this time is most likely limited by the difference in delays between L+R and L-R.

5.3 ADJUSTING THE DELAY NETWORKS

NOTE

1. The 25 Hz pilot tone must be turned off with the front panel switch.
2. The process defeat switch S607 must be in the "DEFEAT" position (located on the night audio circuit card.)
3. CAUTION: Do not touch the following setting on the front panel at this time.
 - 3.1 + LIMIT
 - 3.2 - LIMIT
 - 3.3 BALANCE
4. The night circuit card is an option and may not be used in your Exciter.

5.3.1 Left/Right Delay Adjustments

At this time it might be easier to have the EXCITER placed on a table rather than in a rack so that the switches and controls can be more accessible. Even without setting the delay networks, it is quite possible to achieve 15 dB of separation or more, however, this varies considerable with the transmitter type.

To start the process, set the OSCILLATOR to 1 kHz 50% envelope modulation, LEFT input only. Using an oscilloscope set for X-Y display, observe the LEFT and RIGHT unbalanced signal outputs at the ports J9 and J11 on the monitor. Adjust LEFT DELAY SWITCH S608 from its zero position in 1 microsecond steps for best closure. Compare the oscilloscope display with those shown in Page and .

Repeat procedure for RIGHT input only by adjusting RIGHT DELAY SWITCH S609 from its zero position in 1 microsecond steps for best closure.

5.3.2 Bulk Delay Adjustment

NOTE

If the maximum of 15 microseconds of delay does not produce adequate closure add BULK DELAY CARD D33-335 to the bottom of the NIGHT AUDIO CIRCUIT CARD and connect into circuit. Each switch section on the BULK DELAY CARD adds 8 microseconds of delay for a total of 32 microseconds. The maximum total system delay for both the LEFT and RIGHT audio channels with the BULK DELAY is 32 + 15 or 47 microseconds.

Return the LEFT and RIGHT DELAY SWITCHES S608 and S609 to their ZERO position. Repeat the above procedure for both the LEFT only and RIGHT only sections by adding BULK DELAY in 8 microsecond groups and using LEFT and RIGHT DELAY SWITCHES S608 and S609 for fine adjustment until best closure is obtained.

5.4 EQUALIZATION ADJUSTMENTS

5.4.1 High Frequency Equalization Adjustment

To continue the equalization, set the HI FREQ EQUAL "I" switches on both the DAY and NIGHT CIRCUIT CARDS (S303, S305, S603, S605) to the "OUT" positions. Set the HI FREQ EQUAL "Q" and LOW FREQ EQUAL "Q" switches on both the DAY and NIGHT CIRCUIT CARDS (S304, S306, S302, S301, S604, S606, S602 and S601) to the "IN" position. See Figure 4.

Set the OSCILLATOR to 10 kHz 50% envelope modulation, FRONT PANEL NIGHT/DAY SWITCH to DAY position, LEFT input only.

Adjust LEFT HI FREQ EQUAL CONTROLS, R302 C-D and R389 for best closure.

Change to RIGHT input only and adjust RIGHT HI FREQ EQUAL controls, R302 A-B and R391 for best closure.

5.4.2 Optional Night Function Adjustment

Set FRONT PANEL NIGHT/DAY SWITCH to NIGHT position with EXCITER switched to NIGHT TRANSMITTER.

Repeat LEFT and RIGHT HI FREQ EQUALIZATION using the identical controls on the NIGHT CIRCUIT CARD directly opposite the DAY CIRCUIT CARD controls described above.

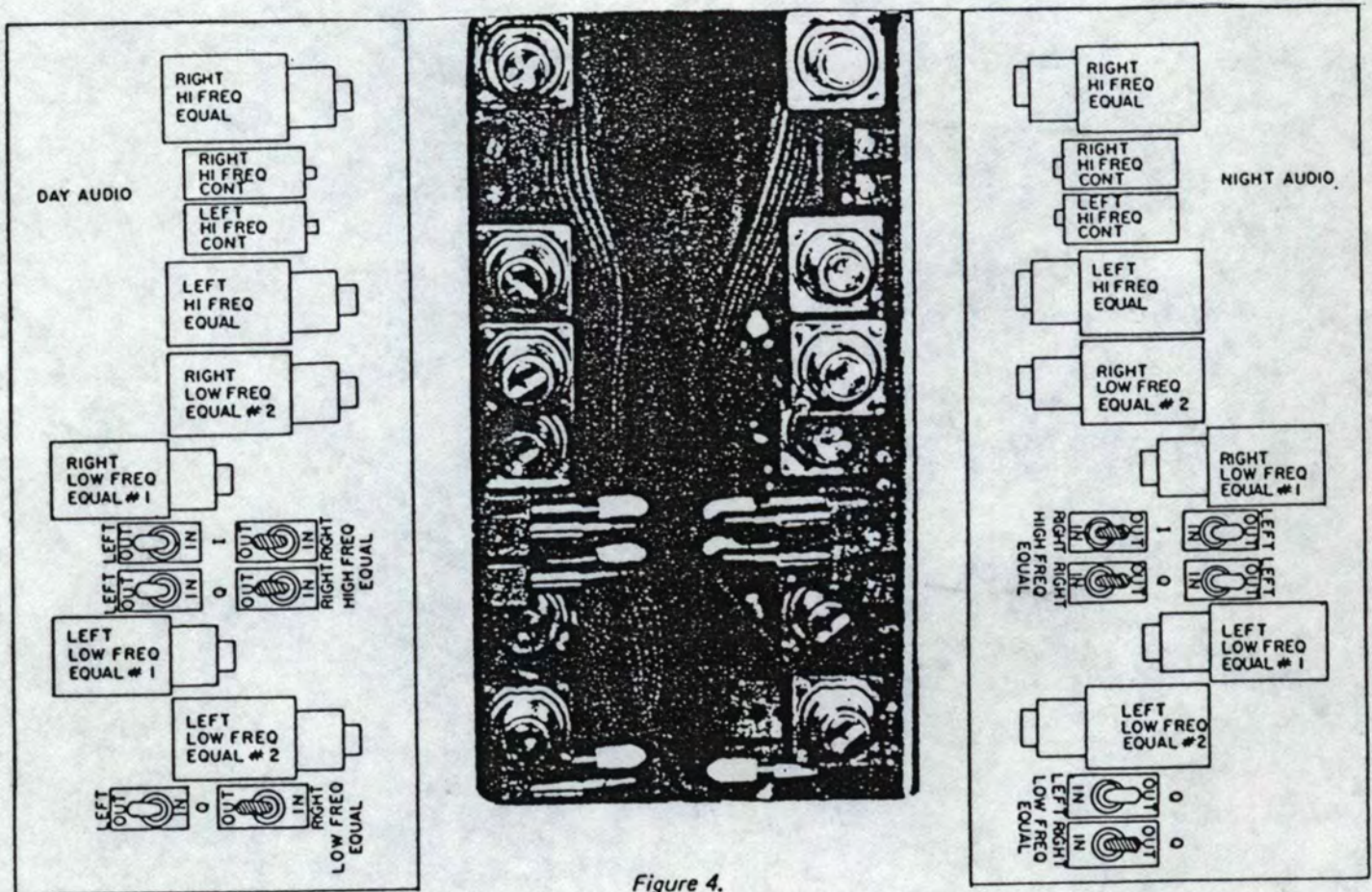

Figure 4.

Exciter Equalization Adjustments (Under Top Cover Access)

5.4.3 Low Frequency Equalization Adjustment

To continue the equalization, set the OSCILLATOR to 100 Hz 50% envelope modulation, FRONT PANEL NIGHT/DAY SWITCH to DAY position LEFT input only.

Adjust LEFT LOW FREQ EQUAL No. 1 and No. 2 controls, R304 C-D and R307 C-D for best closure.

Change to RIGHT input only and adjust RIGHT LOW FREQ EQUAL No. 1 and No. 2 CONTROLS R304A-B and R307 A-B for best closure.

5.4.4 Optional Night Function Adjustment

Set FRONT PANEL NIGHT&DAY SWITCH to NIGHT position with EXCITER switched to NIGHT TRANSMITTER.

Repeat LEFT and RIGHT LOW FREQ EQUALIZATION using the identical controls on the NIGHT CIRCUIT CARD directly opposite the DAY CIRCUIT CARD controls described above.

5.5 SEPARATION CHECKS

Separation measurements should now be made over the audio spectrum with the LEFT channel driven and then the same measurements with the RIGHT channel driven. It is most useful to prepare a graph of the separation in order to judge the action of the various controls. Also, the stereophonic distortion should be measured, that is the LEFT channel distortion when LEFT is driven and the RIGHT channel distortion when RIGHT is driven. Many times there will be a tradeoff between separation and distortion, and there may be very good separation in one direction (RIGHT into LEFT) and marginal separation the other way (LEFT into RIGHT).

At this point, separation should be better than 25 dB both ways. The adjustments will not follow a prescribed pattern, but improvements can be made by trial and error. Include in the adjustments a trimming of the

FRONT PANEL "L+R ADJ" audio drive control. If the transmitter has sufficient low Incidental Phase Modulation (IPM), there should typically be 30 dB separation between 100 Hz and 5 kHz.

The separation below and above this range will be limited by the equalization to precisely match the transmitter, and by bandwidth limits of the transmitter/antenna system.

NOTE

Return the PROCESS DEFEAT SWITCH S607 to the "ON" position.

5.6 OPERATION INTO THE ANTENNA

After satisfactory stereo operation into the dummy load, the final adjustment should be checked by operating into the antenna system during experimental hours. There are two basic effects to look for when operating into the antenna. One is that the impedance/bandwidth of the antenna system often is much narrower than the dummy load and the radiation from the antenna back into the transmitter building can increase the possibility of Incidental Phase Modulation.

With the transmitter operating into the antenna system, measure the stereo separation and distortion. If the high frequency performance (above 5 kHz) has degraded, readjust the high frequency equalization for the best compromise between separation and distortion. If the separation has degraded considerably on all audio frequencies, check the level of Incidental Phase Modulation by modulating the transmitter with the audio oscillator connected directly to the transmitters audio input terminals. Measure the residual L-R out of the MONITOR and compare with previous measurements. If the level is much greater than previously measured into

the DUMMY LOAD, the indication is that the increase in Incidental Phase Modulation is being caused by the RADIATED RF signal from the ANTENNA. Appropriate corrective action must be undertaken.

This completes the check out and adjustment. Tighten all covers and position equipment in its permanent location.

SECTION 6

ASE-1/ASM-1 STEREO SYSTEM EQUIPMENT PERFORMANCE MEASUREMENTS

6.1 INTRODUCTION

The FCC requires AM broadcast stations to conduct equipment performance measurements after installation of AM stereo transmitting equipment. The characteristics to be measured are described in Section 73.1590 and the minimum performance specifications are described in Section 74.40 and 73.128. Copies of these sections of the FCC rules are reproduced in Appendix A.

The FCC requirements are quite extensive and a considerable number of data points must be taken. For the broadcaster's convenience, forms for tabulating and plotting the data are included in this section. A summary of the FCC proof requirements is shown also in Appendix A.

6.2 PROCEDURE

Although the FCC requires that equipment performance measurements be made between a common audio input amplifier at the studio to the transmitting antenna terminals, the following instructions are written to aid the broadcaster in making initial measurements of AM Stereo performance at the transmitter. After satisfactory tests have been completed with the transmitting equipment, the audio oscillator signal can be fed to the required common audio input amplifier at the studio for the actual required performance measurements. Thus, when the following specifies a connection to the Exciter audio input, the connection would then be to the common audio input amplifier at the studio.

Delta will provide to the broadcast station a complete AM Exciter and Modulation Monitor capable of generating and accurately demodulating and indicating the operation of the C-QUAM System. The Modulation Monitor is capable of demodulating and accurately indicating: amplitude modulation, left minus right modulation, left channel modulation, right channel modulation, carrier shift, right or left channel noise levels, separation, and level of pilot tone. In addition, the level of incidental phase modulation can be readily calculated from the left minus right modulation indication when modulating with AM. The frequency of pilot tone modulation can be measured with instruments connected to the modulation monitor. The distortion and noise levels of the modulation monitor are sufficiently low that the measurements made of the various performance characteristics will be reflective of the limits of the broadcast transmitter/stereo encoder performance.

Referring to Figure 2, the measurement of main (L+R) modulation capability is made by paralleling the left (A) and right (B) audio inputs to the stereo Exciter (phased for L+R modulation) and connecting the audio oscillator through the pad to the junction. The main (L+R) modulation can be read directly on the Modulation Monitor by selecting "L+R" for the indication on the left hand meter (see Figure 2). The level of the audio oscillator can be increased until at least 85% modulation is read on the Monitor. The frequency of the oscillator can be varied over the range of 50 to 5000 Hz while observing the level on the Modulation Monitor for the required modulation level.

For (L) left, or (R) right only modulation, the audio oscillator should be directly connected without the pad to first the left (A), and then the right (B) inputs to the AM Stereo Exciter. The oscillator level should

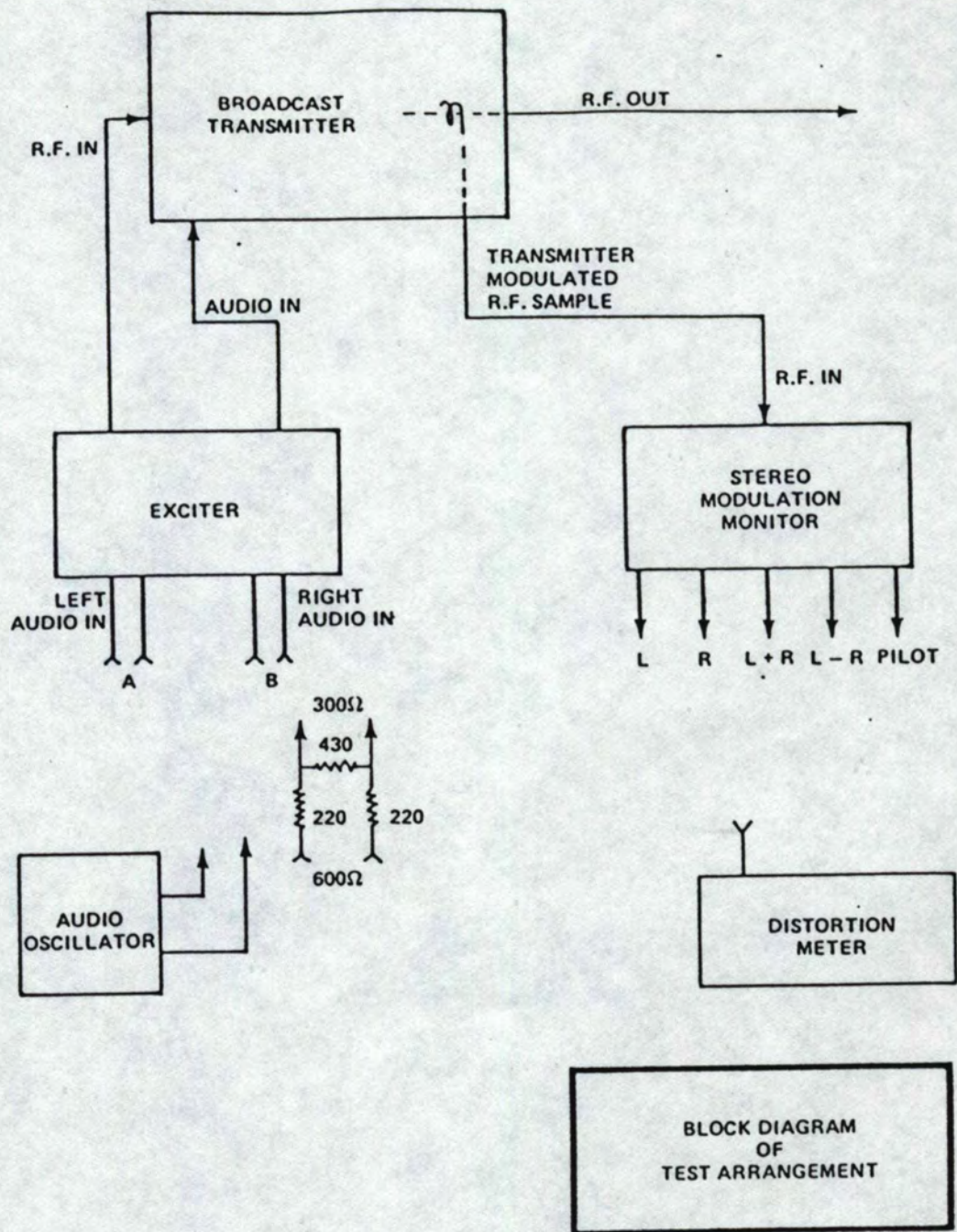

Figure 2.

be advanced until the main channel (L+R) modulation reaches at least 75% modulation as indicated on the Monitor. The oscillator frequency is then varied over the range of 50 to 5000 Hz while observing the Monitor.

For measurement of distortion, the audio oscillator is connected to the Stereo Exciter as previously described. For main (L+R) distortion measurements, the distortion meter should be connected to the BNC connector on the rear of the Modulation Monitor labeled "L+R". For left or right distortion measurements, connect the oscillator directly to the left input on the Exciter and connect the distortion analyzer to the left output on the Modulation Monitor. The same process is repeated for right only distortion measurements. If the 600 ohm balanced output is used, terminate with a 600 ohm load.

The audio oscillator is connected as previously described for main (L+R), left (L) and right (R) modulation. The frequency response can be directly observed by selecting "L+R" for main channel response or "L" for the left channel response on the left meter or "R" for right channel response on the right meter of the Modulation Monitor. Response can also be read on the distortion meter in the audio voltmeter function by connecting to the appropriate left, right or left + right outputs of the Modulation Monitor at the rear of the unit.

The carrier shift can be read by observing the carrier level indicator on the C-QUAM AM Stereo Modulation Monitor or on the station's type approved amplitude modulation monitor. With no modulation applied to the AM Stereo Exciter, the carrier level indicator should be carefully set to the zero or calibrate point. The audio oscillator is to be connected to the paralleled left and right inputs of the AM Stereo encoder (phased for L+R modulation) through the pad. The output level of the oscillator is to

be advanced while observing the carrier level indicator in the modulation monitor. The maximum change in carrier level indication is to be recorded for modulation levels from zero to 100% amplitude modulation.

Figure 2.

Both left (L) and right (R) audio inputs to the AM Stereo Exciter are terminated with 600 ohm resistors. Main (L+R), left (L) and right (R) channel noise levels can be directly read on the C-QAM AM Stereo Modulation Monitor by selecting the appropriate mode for the left or right meters, and depressing the meter range buttons until an on scale reading is obtained. The noise level is obtained by adding the meter range value with the indication of the red dB scale on the meter. It is already calibrated against 100 percent modulation.

Incidental phase modulation is measured as follows. Connect the audio oscillator through the pad to the parallel left and right audio inputs to the Stereo Exciter, making sure that the audio inputs are phased for main (L+R) modulation. The left hand meter is set to (L+R) on the Modulation Monitor and the right hand meter is set to (L-R). The audio oscillator output is adjusted to the various modulation levels and audio frequencies required and the readings of the (L-R) meter is observed. The meter range will have to be chosen by selecting the appropriate pushbutton. Record the sum of the pushbutton meter range and the red dB scale on the (L-R) meter for each combination of modulation level and frequency. The incidental phase modulation in radians is simply the voltage ratio below 100 percent

L-R modulation expressed in decimal form. For instance, if the observed L-R modulation is 50 dB below 100 percent L-R modulation, the incidental phase modulation is .0032 radians or 3.2×10^{-3} radians.

For measurement of separation, the audio oscillator is connected directly to the (L) left or (R) right input of the AM Stereo Exciter. The left channel is modulated with a tone and a distortion meter or audio voltmeter is used to measure the audio output voltage from the left channel output of the Modulation Monitor. The audio voltage from the right channel output of the Modulation Monitor is then measured. The difference in dB is the separation. The reverse process is used to measure the separation of a modulated right channel into the left.

The front panel meters can be used directly when set to "L" and "R". The separation can be read directly on the panel meters with the meter range buttons only for 100 percent left or right only modulation. For lesser values of left or right only modulation, separation is computed by subtracting the readings in dB of the two meters added to the respective pushbutton settings.

The relative pilot tone level may be measured directly on the Modulation Monitor by setting the small toggle switch under the carrier meter to the "pilot tone" side and reading the level of pilot tone on the carrier level panel meter. The correct level of pilot tone indication should be at the black block on the meter scale. To accurately measure the pilot level, set pushbuttons L-R and -20. The meter should indicate -26 dB.

Pilot tone frequency may be measured from the pilot tone port on the back of the Modulation Monitor. Use Sigmetek ITC-3 frequency counter or similar computing counter. Pilot tone should be 25 Hz +/-0.1 Hz.

SECTION 7
LISTS OF MATERIAL

SECTION 8
SCHEMATIC DIAGRAMS

REVISIONS				
SYM	ZONE	DESCRIPTION	DATE	APPROVED
SEE SHEET (0) OF 8D33-336 FOR REVISIONS				

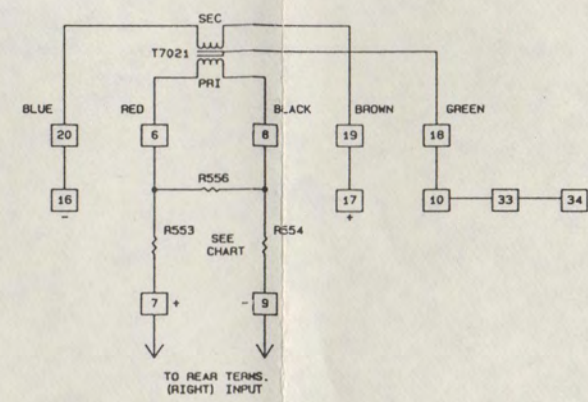
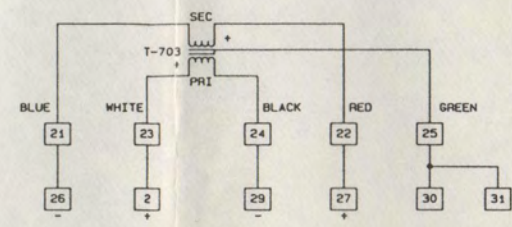
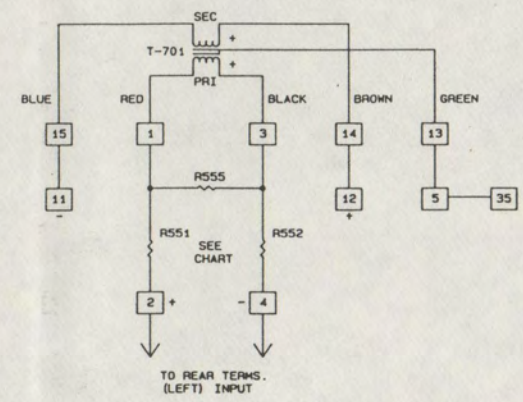

100X MODULATION		
STATION LEFT & RIGHT AUDIO INPUT INTO 500 OHMS DBM	R555 & R556 1X OHMS	R551-R554 1X OHMS
+10	113	249
+8	147	243
+6	205	226
+4	280	205
+2	402	182
0	604	150
-2	1020	110
-4	2260	61.9
-6	INF.	0

NOTES: 1. MODULATION CHART INDICATES RESISTORS AS REQUIRED PER CUSTOMER SPECIFICATION.

REF DES PREFIX "A700"

If You Didn't Get This From My Site,
Then It Was Stolen From...
www.SteamPoweredRadio.Com

THIS DRAWING AND SPECIFICATIONS ARE THE PROPERTY OF DELTA ELECTRONICS, INC. AND SHALL NOT BE REPRODUCED OR COPIED OR USED AS THE BASIS FOR THE MANUFACTURE OR SALE OF APPARATUS WITHOUT PERMISSION.

UNLESS OTHERWISE SPECIFIED DIMENSIONS ARE IN INCHES		DRAWN: <i>m. scale</i> DATE: <i>1/2/85</i>	DELTA ELECTRONICS, INC. ALEXANDRIA, VIRGINIA	
TOLERANCES FRACTIONS DECIMALS ANGLES		CHECKED: <i>m. A. e.</i>	AUDIO INTERFACE ASSEMBLY	
		ENGINEER: <i>m. A. e.</i>		
MATERIAL: L/M:8		APPROVED:	CONTRACT NO.	REL. DATE
FINISH:		DESIGN ACTIVITY APPROVAL	CODE IDENT NO.	SIZE
ASE-1		APPROVED	19482	D
NEXT ASSY USED ON			DRAWING NO.	REV.
APPLICATION			4D33-336	1
			SCALE: NONE	SHEET 1 OF 1

4D33-336 E

REVISIONS				
SYM	ZONE	DESCRIPTION	DATE	APPROVED
SEE SHEET (O) OF 8D33-320 FOR REVISIONS				

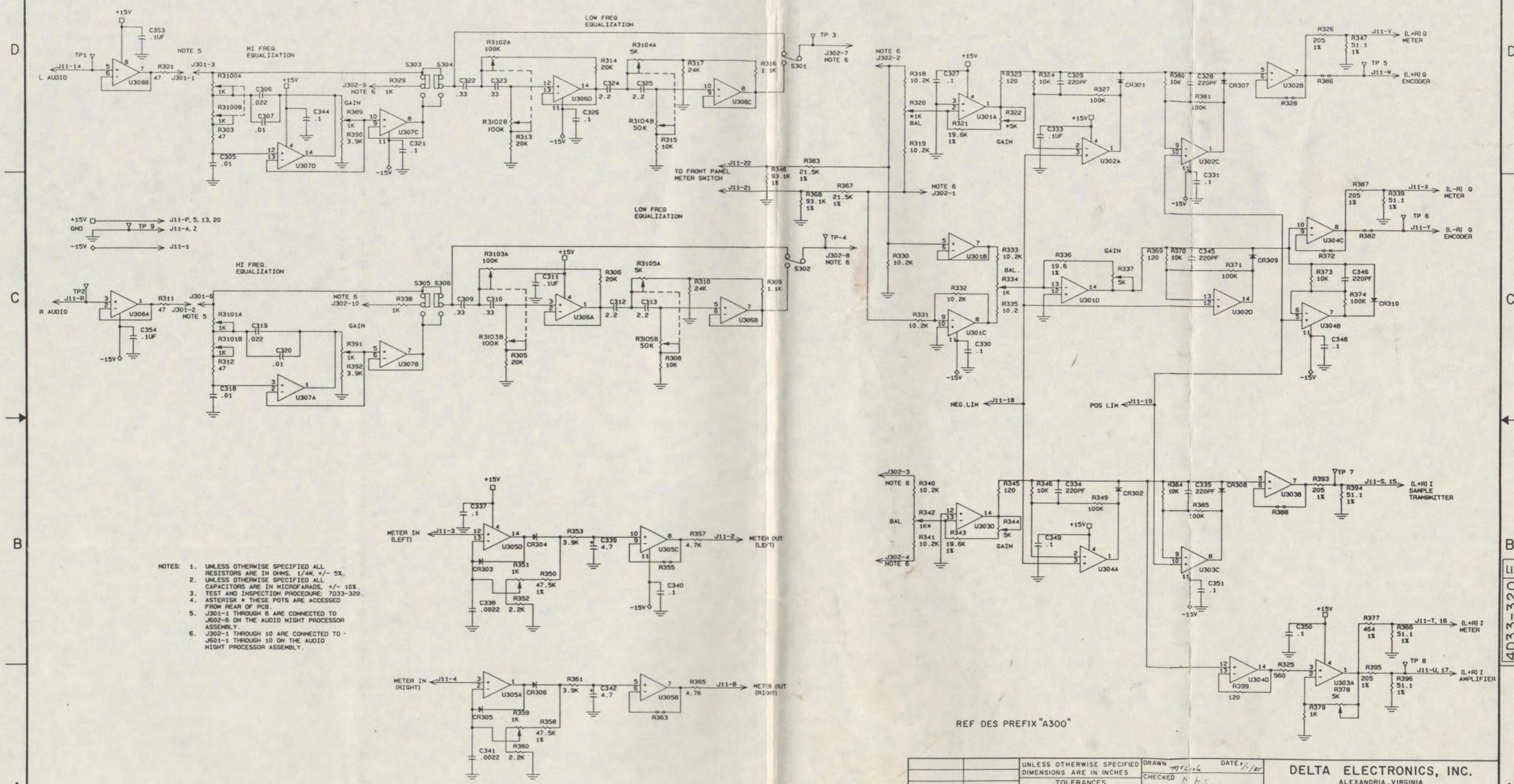

- NOTES:
- UNLESS OTHERWISE SPECIFIED ALL RESISTORS ARE IN OHMS, 1/4W, +/- 5%.
 - UNLESS OTHERWISE SPECIFIED ALL CAPACITORS ARE IN MICROFARADS, +/- 10%.
 - TEST AND INSPECTION PROCEDURE: 7033-320.
 - ASTERISK * THESE POTS ARE ACCESSED FROM REAR OF PCB.
 - J301-1 THROUGH 6 ARE CONNECTED TO J302-6 ON THE AUDIO NIGHT PROCESSOR ASSEMBLY.
 - J302-1 THROUGH 10 ARE CONNECTED TO J601-1 THROUGH 10 ON THE AUDIO NIGHT PROCESSOR ASSEMBLY.

REF DES PREFIX "A300"

THESE DIMENSIONS AND SPECIFICATIONS ARE THE PROPERTY OF DELTA ELECTRONICS, INC. AND SHALL NOT BE REPRODUCED OR COPIED OR USED IN ANY MANNER WITHOUT THE WRITTEN PERMISSION OF DELTA ELECTRONICS, INC.

UNLESS OTHERWISE SPECIFIED DIMENSIONS ARE IN INCHES	DRAWN: <i>W.C. G.</i> DATE: <i>1/1/81</i>	DELTA ELECTRONICS, INC. ALEXANDRIA, VIRGINIA
TOLERANCES FRACTIONS DECIMALS ANGLES	CHECKED: <i>J.H.S.</i> ENGINEER: <i>J.H.S.</i> APPROVED: _____	
MATERIAL:	CONTRACT NO. _____ REL. DATE _____	AUDIO EQUALIZATION, MATRIX ASSEMBLY
FINISH: ASE-1	DESIGN ACTIVITY APPROVAL _____	CODE IDENT NO. 19482 SIZE D DRAWING NO. 4D33-320
NEXT ASSY USED ON _____	APPROVED _____	SCALE: NONE SHEET 1 OF 1
APPLICATION _____		

If You Didn't Get This From My Site,
Then It Was Stolen From...
www.SteamPoweredRadio.Com

4D33-320

REVISIONS				
SYM	ZONE	DESCRIPTION	DATE	APPROVED
SEE SHEET (0) OF 8033-334 FOR REVISIONS				

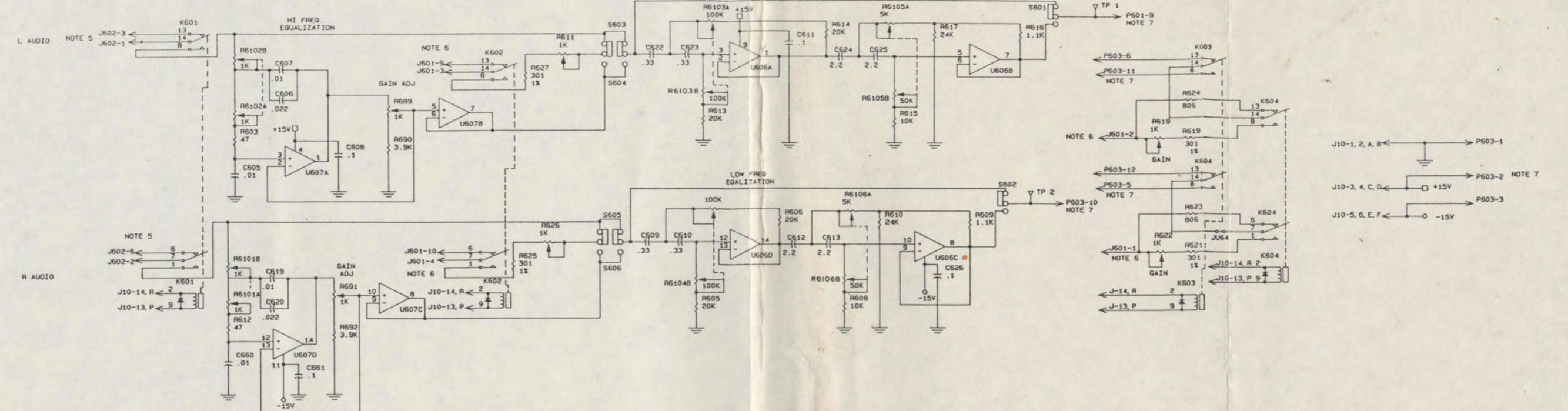

- NOTES:
- UNLESS OTHERWISE SPECIFIED, ALL RESISTORS ARE IN OHMS, 1/4W, +/- 5%.
 - UNLESS OTHERWISE SPECIFIED, ALL CAPACITORS ARE IN MICROFARADS, +/- 10%.
 - TEST AND INSPECTION PROCEDURE: 7D33-334.
 - SWITCHES S608 & S609 DRAWN IN "0" BINARY MODE HEXADECIMAL.
 - J602-1 THROUGH 6 ARE CONNECTED TO J301-1 THROUGH 6 ON THE AUDIO EQUALIZATION MATRIX ASSEMBLY.
 - J601-1 THROUGH 10 ARE CONNECTED TO J302-1 THROUGH 10 ON THE AUDIO EQUALIZATION MATRIX ASSEMBLY.
 - J603-1 THROUGH 12 ARE CONNECTED TO THE DELAY MOUNTING BOARD.
 - U601, U602, U603, U606, U607 ARE TL084CN.
 - U604 IS VACTEC VTL5C1.

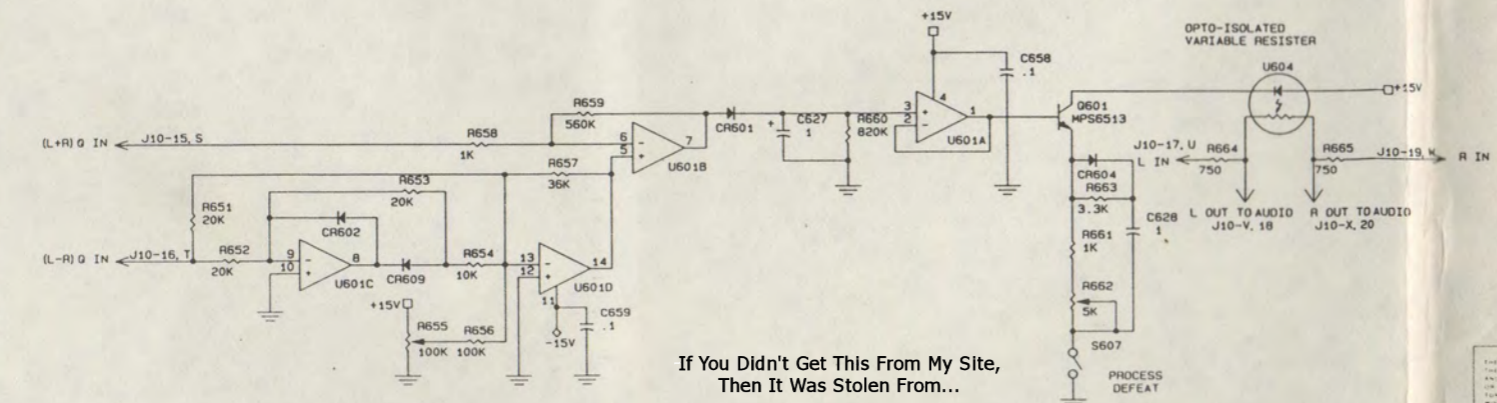
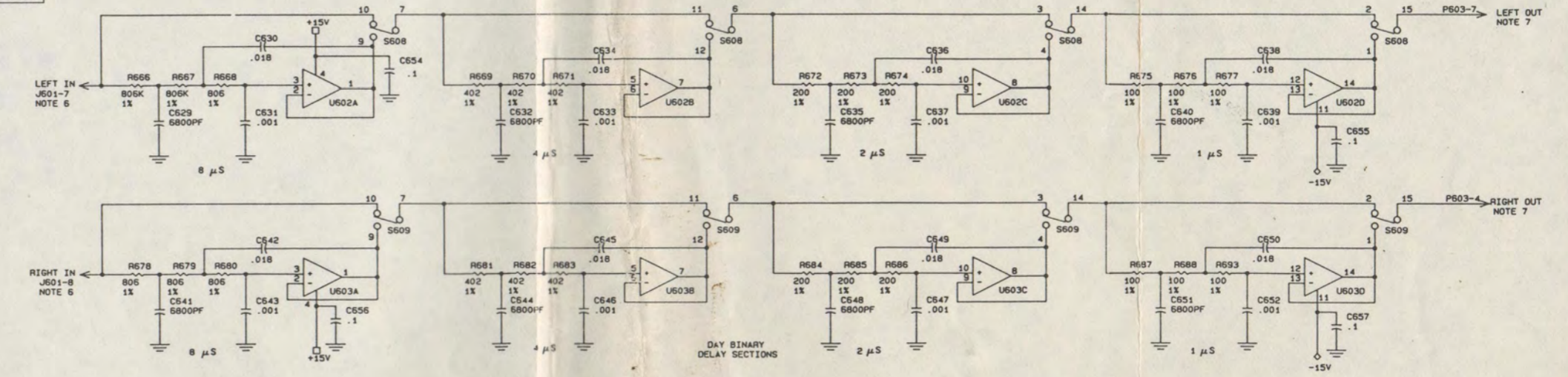

If You Didn't Get This From My Site,
Then It Was Stolen From...
www.SteamPoweredRadio.Com

UNLESS OTHERWISE SPECIFIED DIMENSIONS ARE IN INCHES		DRAWN <i>James M. Page</i> DATE <i>2/85</i>		DELTA ELECTRONICS, INC. ALEXANDRIA, VIRGINIA	
TOLERANCES: FRACTIONS DECIMALS ANGLES		CHECKED <i>...</i> ENGINEER <i>...</i>			
MATERIAL:		CONTRACT NO.		AUDIO NIGHT PROCESSOR ASSEMBLY	
L/M:8		REL DATE			
FINISH:		DESIGN ACTIVITY APPROVAL		CODE IDENT NO	SIZE
NEXT ASSY USED ON APPLICATION		APPROVED		19482	D
				DRAWING NO.	REV.
				4D33-334	
				SCALE: NONE	SHEET 1 OF 1

4D33-334

8 7 6 5 4 3 2 1

REVISIONS			
SYM	ZONE	DESCRIPTION	DATE
SEE SHEET (0) OF 8D33-335 FOR REVISIONS			

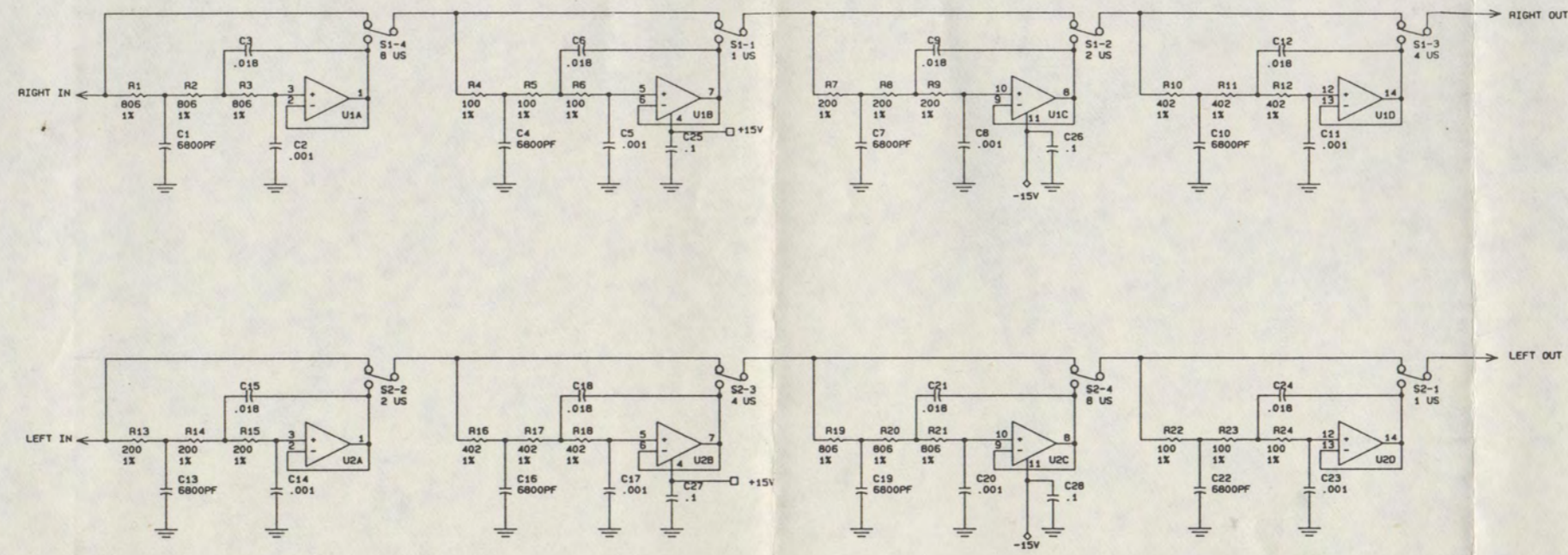

- NOTES:
1. UNLESS OTHERWISE SPECIFIED, ALL RESISTORS ARE IN OHMS, 1/4W, +/- 5%.
 2. UNLESS OTHERWISE SPECIFIED ALL CAPACITORS ARE IN MICROFARADS, +/- 10%.
 3. TEST AND INSPECTION PROCEDURE: 7033-335.
 4. U1, U2 ARE LF347BM OR TL084CH.
 5. 033-335-1: EACH STEP=1 MICROSECOND. 033-335-2: EACH STEP=8 MICROSECONDS.
 6. SWITCH DELAYS AND RESISTOR VALUES SHOWN FOR -1 ASSEMBLY. FOR -2 ASSEMBLY R1-R24 ARE 806 OHMS.

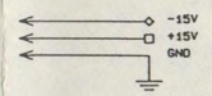

REF DES PREFIX "A1"

If You Didn't Get This From My Site,
Then It Was Stolen From...
www.SteamPoweredRadio.Com

THESE DRAWINGS AND SPECIFICATIONS ARE THE PROPERTY OF DELTA ELECTRONICS, INC. AND SHALL NOT BE REPRODUCED OR COPIED OR USED IN THE MANUFACTURE OF ANY APPARATUS WITHOUT PERMISSION.

UNLESS OTHERWISE SPECIFIED DIMENSIONS ARE IN INCHES		DRAWN: <i>mcc</i> DATE: 1/13/85	DELTA ELECTRONICS, INC. ALEXANDRIA, VIRGINIA	
TOLERANCES		CHECKED: <i>M A C</i>	BULK DELAY TB ASSEMBLY	
FRACTIONS DECIMALS ANGLES		ENGINEER: <i>M A C</i> 11/20/85		
MATERIAL:		APPROVED: _____	CONTRACT NO.	REL. DATE
L/M: 8		DESIGN ACTIVITY APPROVAL	CODE IDENT NO	SIZE
ASE-1	FINISH:	APPROVED	19482	D
NEXT ASSY USED ON APPLICATION			DRAWING NO.	REV.
			4D33-335	
			SCALE: NONE	SHEET 1 OF 1

4D33-335 F

095-768

8 7 6 5 4 3 2 1

REVISIONS			
SYM	ZONE	DESCRIPTION	DATE
SEE SHEET (0) OF 8D33-319 FOR REVISIONS			

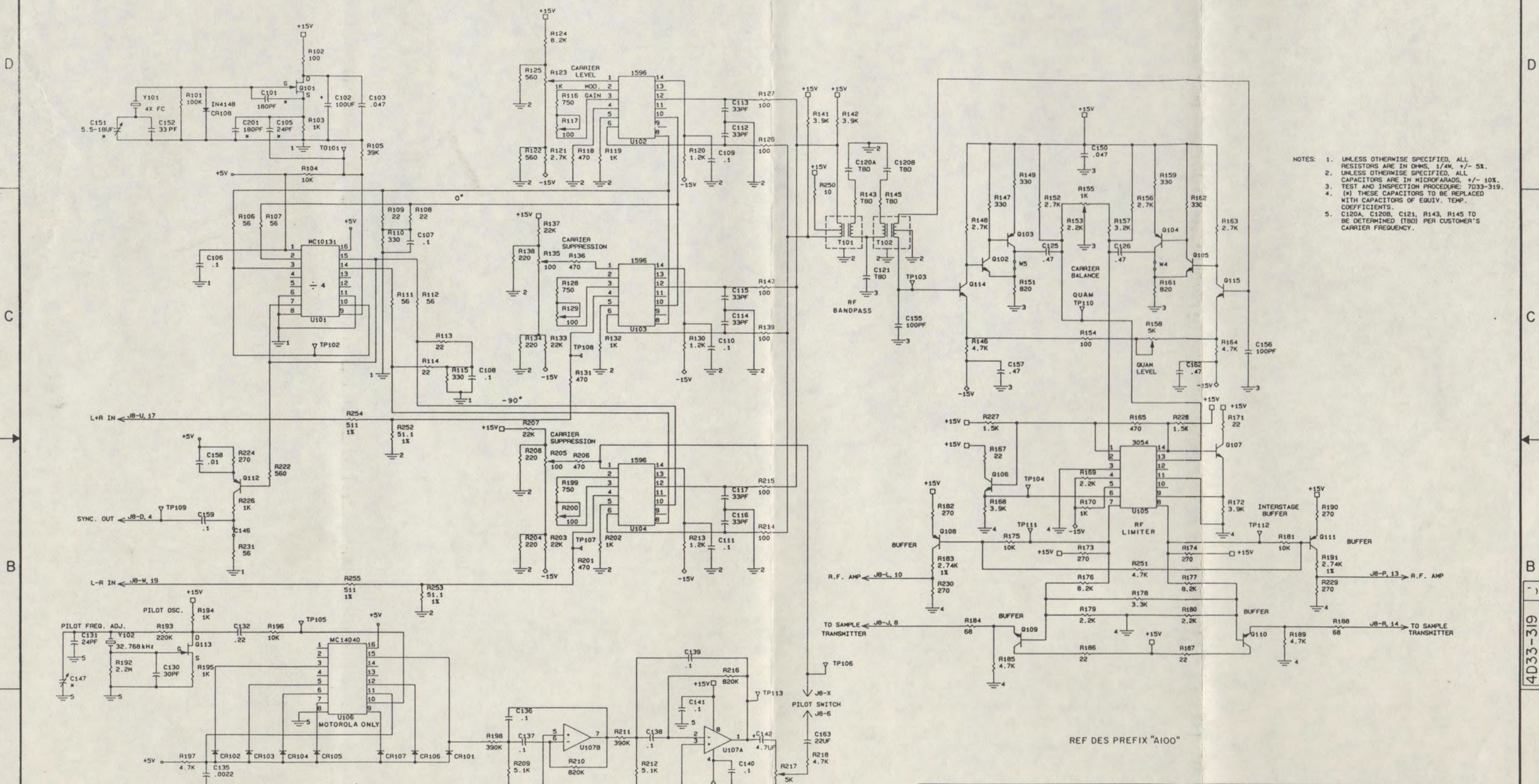

- NOTES:
- UNLESS OTHERWISE SPECIFIED, ALL RESISTORS ARE IN OHMS, 1/4W, +/- 5%.
 - UNLESS OTHERWISE SPECIFIED, ALL CAPACITORS ARE IN MICROFARADS, +/- 10%.
 - TEST AND INSPECTION PROCEDURE: 7033-319.
 - (*) THESE CAPACITORS TO BE REPLACED WITH CAPACITORS OF EQUIV. TEMP. COEFFICIENTS.
 - C120A, C120B, C121, R143, R145 TO BE DETERMINED (TBD) PER CUSTOMER'S CARRIER FREQUENCY.

REF DES PREFIX "A100"

<p>0.95-768</p> <p>If You Didn't Get This From My Site, Then It Was Stolen From... www.SteamPoweredRadio.Com</p>	<p>UNLESS OTHERWISE SPECIFIED DIMENSIONS ARE IN INCHES</p> <p>TOLERANCES</p> <p>FRACTIONS DECIMALS ANGLES</p> <p>MATERIAL:</p> <p>L/M: 8</p> <p>FINISH:</p> <p>ASE-1</p> <p>NEXT ASSY USED ON</p> <p>APPLICATION</p>	<p>DRAWN <i>Odey</i> DATE 4/1/85</p> <p>CHECKED <i>A.A.</i></p> <p>ENGINEER <i>A.A.</i></p> <p>APPROVED</p> <p>CONTRACT NO.</p> <p>REL DATE</p> <p>DESIGN ACTIVITY APPROVAL</p> <p>APPROVED</p>	<p>DELTA ELECTRONICS, INC.</p> <p>ALEXANDRIA, VIRGINIA</p> <p>ENCODER ASSEMBLY</p> <p>CODE IDENT NO 19482</p> <p>SIZE D</p> <p>DRAWING NO. 4D33-319</p> <p>REV. J</p> <p>SCALE NONE</p> <p>SHEET 1 OF 1</p>
--	--	---	---

4D33-319

REVISIONS			
SYM	ZONE	DESCRIPTION	DATE
SEE SHEET (O) OF 8D33-321 FOR REVISIONS			

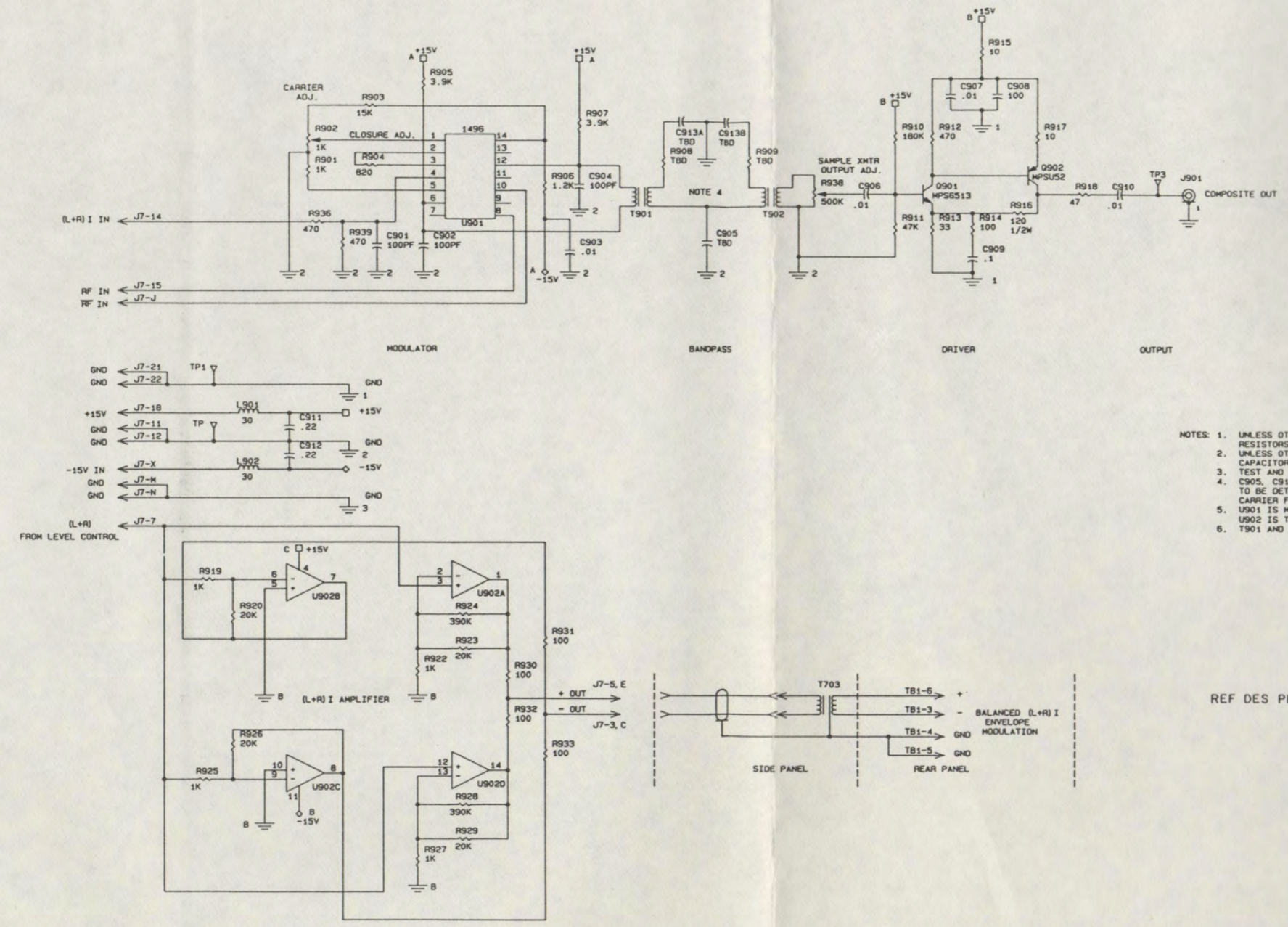

- NOTES:
1. UNLESS OTHERWISE SPECIFIED, ALL RESISTORS ARE IN OHMS, 1/4W, +/- 5%.
 2. UNLESS OTHERWISE SPECIFIED, ALL CAPACITORS ARE IN MICROFARADS, +/- 10%.
 3. TEST AND INSPECTION PROCEDURE: 7033-321.
 4. C905, C913A, C913B, R908, R909: VALUES TO BE DETERMINED (TBD) PER CUSTOMER'S CARRIER FREQ.
 5. U901 IS MC1495
U902 IS TL084CN
 6. T901 AND T902 ARE B2-0406.

REF DES PREFIX "A900"

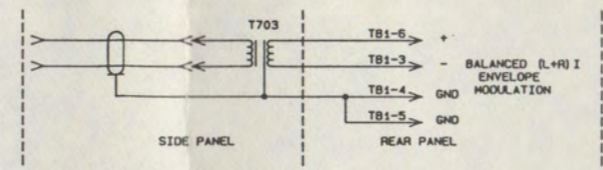

UNLESS OTHERWISE SPECIFIED DIMENSIONS ARE IN INCHES		DRAWN <i>m*Coole</i>	DATE <i>4/1/85</i>	DELTA ELECTRONICS, INC. ALEXANDRIA, VIRGINIA	
TOLERANCES FRACTIONS DECIMALS ANGLES		CHECKED <i>[Signature]</i>	ENGINEER <i>[Signature]</i>	L & R AMPLIFIER / SAMPLE TRANSMITTER ASSEMBLY	
MATERIAL:		APPROVED	CONTRACT NO.	REL. DATE	CODE IDENT NO
L/M:8		DESIGN ACTIVITY APPROVAL	19482	SIZE D	DRAWING NO. 4D33-321
FINISH:		APPROVED	SCALE: NONE	SHEET 1 OF 1	
NEXT ASSY USED ON APPLICATION					

THESE DRAWINGS AND SPECIFICATIONS ARE THE PROPERTY OF DELTA ELECTRONICS, INC. AND SHALL NOT BE REPRODUCED OR COPIED OR USED AS THE BASIS FOR THE MANUFACTURE OR SALE OF APPARATUS WITHOUT PERMISSON.

If You Didn't Get This From My Site,
Then It Was Stolen From...
www.SteamPoweredRadio.Com

4D33-321 C

REVISIONS				
SYM	ZONE	DESCRIPTION	DATE	APPROVED
SEE SHEET (0) OF 8D33-322 FOR REVISIONS				

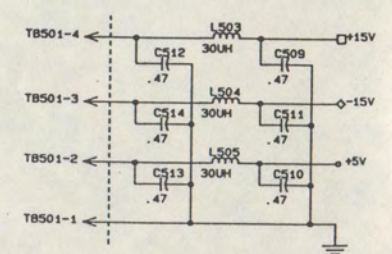
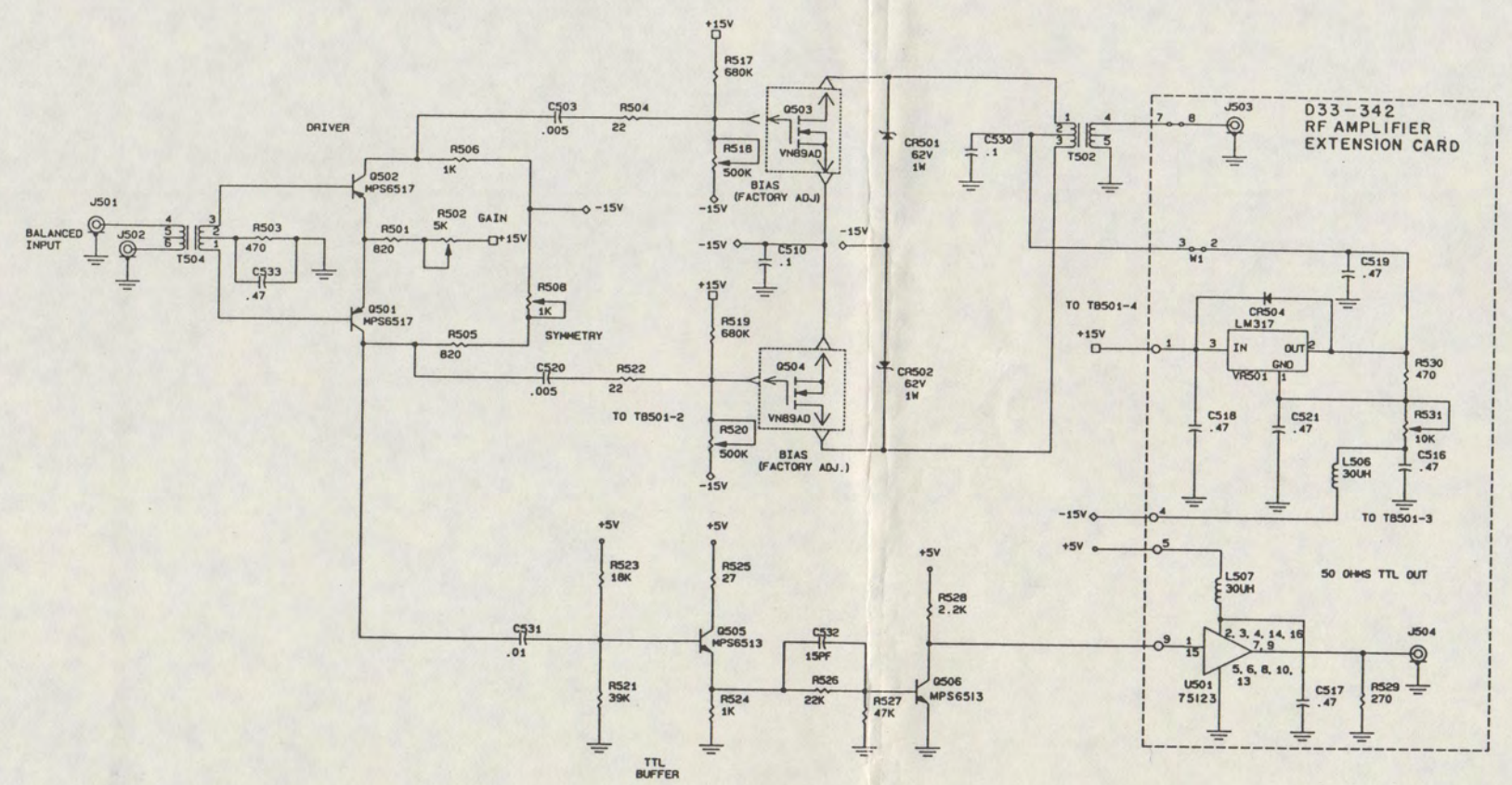

- NOTES:
1. UNLESS OTHERWISE SPECIFIED, ALL RESISTORS ARE IN OHMS 1/4K +/- 5K.
 2. UNLESS OTHERWISE SPECIFIED, ALL CAPACITORS ARE IN MICROFARADS, +/- 10%.
 3. TEST AND INSPECTION PROCEDURE: 7D33-322.
 4. ALL INDUCTORS IN MICROHENRYS UNLESS OTHERWISE INDICATED.
 5. Q503 AND Q504 ARE MOUNTED ON LEFT SIDE PANEL.
 6. SUB-ASSEMBLY D33-342, SHOWN ENCLOSED IN LARGE DASHED LINE, IS MOUNTED ON D33-322.

REF DES PREFIX "A500"

If You Didn't Get This From My Site,
Then It Was Stolen From...
www.SteamPoweredRadio.Com

THESE DRAWINGS AND SPECIFICATIONS ARE THE PROPERTY OF DELTA ELECTRONICS, INC. AND SHALL NOT BE REPRODUCED OR COPIED OR USED AS THE BASIS FOR THE MANUFACTURE OR SALE OF APPARATUS WITHOUT PERMISSION.

UNLESS OTHERWISE SPECIFIED DIMENSIONS ARE IN INCHES		DRAWN	DATE	DELTA ELECTRONICS, INC.	
TOLERANCES		CHECKED	1/1/75	ALEXANDRIA, VIRGINIA	
FRACTIONS DECIMALS ANGLES		ENGINEER	1/2/75	RF AMPLIFIER ASSEMBLY	
MATERIAL:		APPROVED		CONTRACT NO.	REL. DATE
L/M:8		DESIGN ACTIVITY APPROVAL		CODE IDENT NO.	SIZE
ASM-I	FINISH:	APPROVED		19482	D
NEXT ASSY USED ON	APPLICATION			DRAWING NO.	REV.
				4D33-322	D
				SCALE: NONE	SHEET 1 OF 1

4D33-322 D

D95-76B

8

7

6

5

4

3

2

1

REVISIONS				
SYM	ZONE	DESCRIPTION	DATE	APPROVED
SEE SHEET (O) OF 8D33-323 FOR REVISIONS				

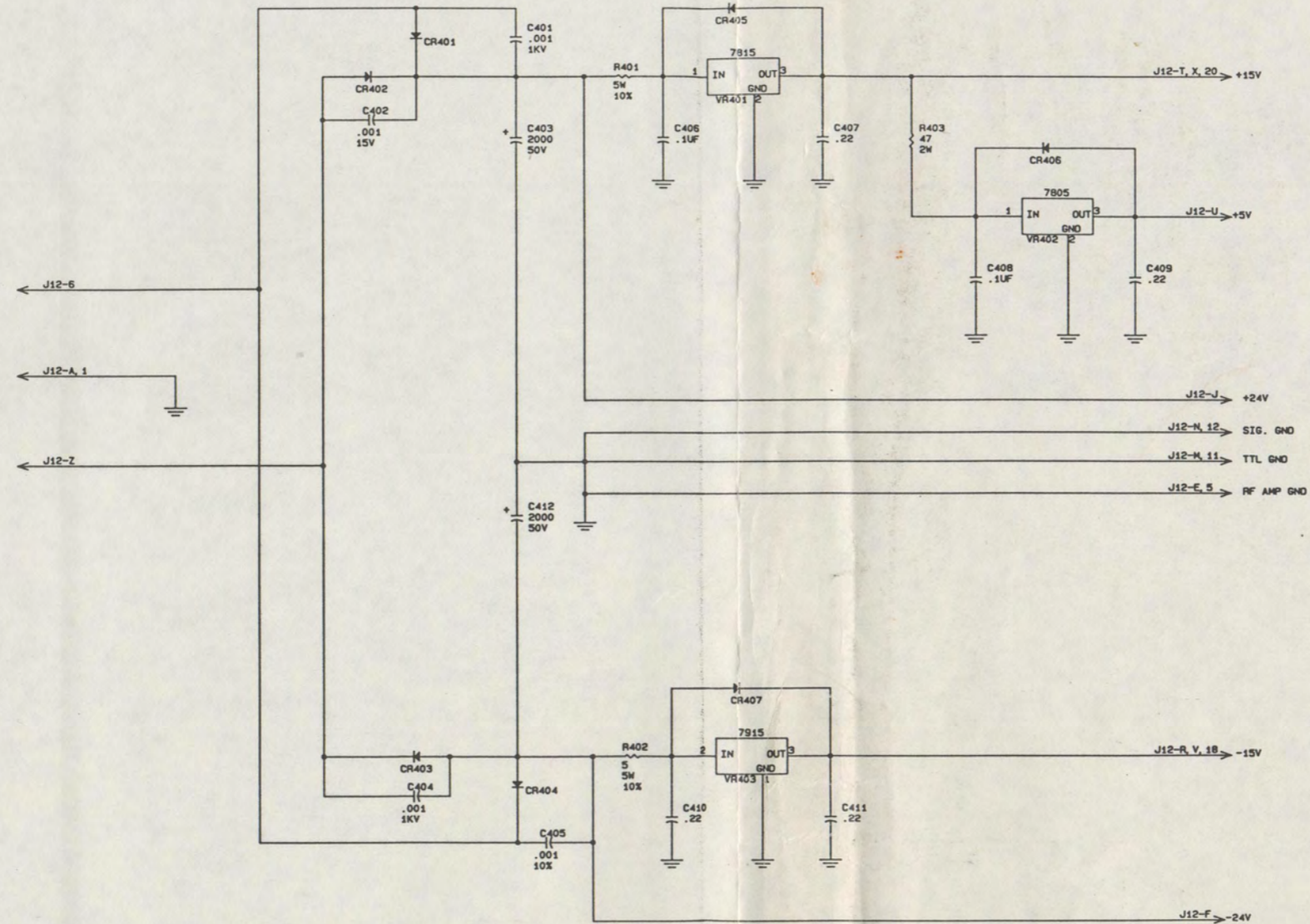

- NOTES: 1. UNLESS OTHERWISE SPECIFIED ALL RESISTORS ARE IN OHMS, 1/4W, +/- 5%.
 2. UNLESS OTHERWISE SPECIFIED ALL CAPACITORS ARE IN MICROFARADS, +/- 10%.
 3. TEST AND INSPECTION PROCEDURE: 7D33-323.
 4. CR401, CR402, CR403, CR404 ARE 1N4720. CR405, CR406, CR407 ARE 1N4002.
 5. VOLTAGE REGULATORS ARE MOUNTED ON RIGHT SIDE PANEL HEATSINK.

REF DES PREFIX "A400"

4D33-323

THESE DRAWINGS AND SPECIFICATIONS ARE THE PROPERTY OF DELTA ELECTRONICS, INC. AND SHALL NOT BE REPRODUCED, COPIED, OR USED AS THE BASIS FOR THE MANUFACTURE OR SALE OF APPARATUS WITHOUT PERMISSION.

UNLESS OTHERWISE SPECIFIED DIMENSIONS ARE IN INCHES		DRAWN <i>John M. Payne</i> DATE <i>1/1/85</i>		DELTA ELECTRONICS, INC. ALEXANDRIA, VIRGINIA	
TOLERANCES FRACTIONS DECIMALS ANGLES		CHECKED <i>MA</i>		POWER SUPPLY ASSEMBLY	
		ENGINEER <i>MA</i> DATE <i>1/1/85</i>			
MATERIAL: L/M: 8		APPROVED _____		CONTRACT NO. _____ REL. DATE _____	
FINISH: _____		DESIGN ACTIVITY APPROVAL _____		CODE IDENT NO. _____ SIZE _____ DRAWING NO. _____ REV. _____	
NEXT ASSY USED ON APPLICATION _____		APPROVED _____		19482 D 4D33-323	
				SCALE: NONE SHEET 1 OF 1	

If You Didn't Get This From My Site,
 Then It Was Stolen From...
www.SteamPoweredRadio.Com

D95-768

8

7

6

5

4

3

2

1

REVISIONS			
SY#	ZONE	DESCRIPTION	DATE APPROVED
SEE SHEET (O) OF 8033-324 FOR REVISIONS			

- NOTES:
1. UNLESS OTHERWISE SPECIFIED, ALL RESISTORS ARE IN OHMS, 1/4W, +/-5%.
 2. UNLESS OTHERWISE SPECIFIED, ALL CAPACITORS ARE IN MICROFARADS, +/- 10%.
 3. TEST AND INSPECTION PROCEDURE: 7033-324.
 4. U750 IS TL081CP.

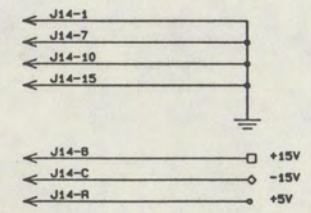
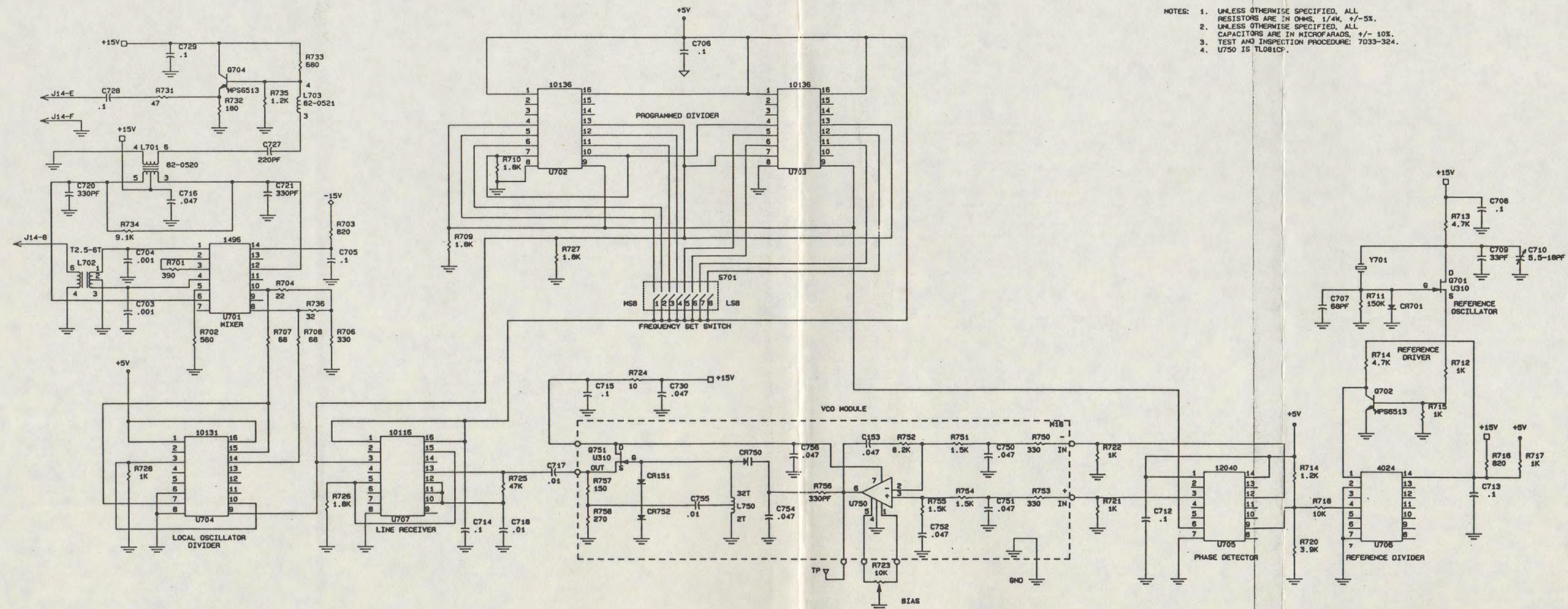

REF DES PREFIX "A700"

THESE DRAWINGS AND SPECIFICATIONS ARE THE PROPERTY OF DELTA ELECTRONICS, INC. AND SHALL NOT BE REPRODUCED OR COPIED, OR USED AS THE BASIS FOR THE MANUFACTURE OR SALE OF APPARATUS WITHOUT PERMISSION.

UNLESS OTHERWISE SPECIFIED DIMENSIONS ARE IN INCHES	DRAWN <i>James M. Gorman</i> DATE <i>4/1/85</i>	DELTA ELECTRONICS, INC. ALEXANDRIA, VIRGINIA	
TOLERANCES FRACTIONS DECIMALS ANGLES	CHECKED <i>M.A.P.</i> ENGINEER <i>M.A.P.</i> 4/1/85	FREQUENCY CONVERTER ASSEMBLY	
MATERIAL: L/M:8	APPROVED _____ CONTRACT NO. _____ REL. DATE _____	DESIGN ACTIVITY APPROVAL	CODE IDENT NO. 19482 SIZE D DRAWING NO. 4D33-324 REV. _____
FINISH: _____	APPROVED _____	SCALE: NONE	SHEET 1 OF 1
ASM-I NEXT ASSY USED ON APPLICATION			

If You Didn't Get This From My Site,
Then It Was Stolen From...
www.SteamPoweredRadio.Com

4D33-324

REVISIONS		
SYN	ZONE	DESCRIPTION
		SEE SHEET (0) OF 8D33-332 FOR REVISIONS
DATE	APPROVED	

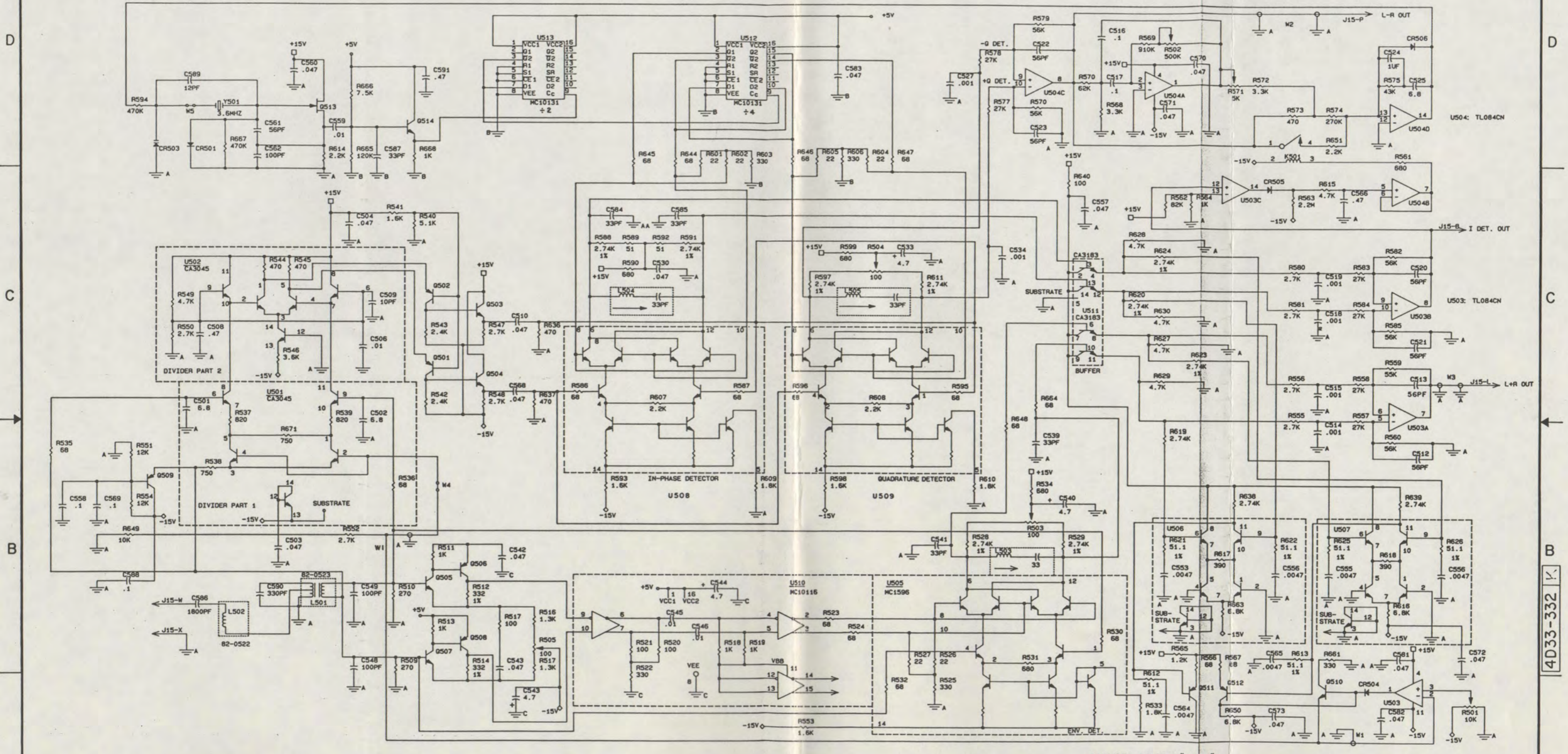

NOTES: 1. UNLESS OTHERWISE SPECIFIED, ALL RESISTORS ARE IN OHMS, 1/4W, +/- 5%.
 2. UNLESS OTHERWISE SPECIFIED, ALL CAPACITORS ARE IN MICROFARADS, +/- 10%.
 3. TEST AND INSPECTION PROCEDURE: 7033-332.

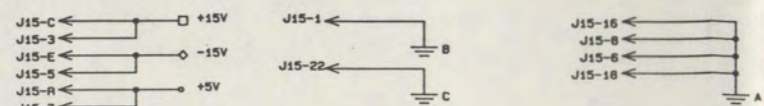

If You Didn't Get This From My Site,
 Then It Was Stolen From...
www.SteamPoweredRadio.Com

THESE DRAWINGS AND SPECIFICATIONS ARE THE PROPERTY OF DELTA ELECTRONICS, INC. AND SHALL NOT BE REPRODUCED OR COPIED OR USED AS THE BASIS FOR THE MANUFACTURE OR SALE OF APPARATUS WITHOUT PERMISSION.

UNLESS OTHERWISE SPECIFIED DIMENSIONS ARE IN INCHES	DRAWN <i>Delany M. Payne</i> DATE 4/2/65
TOLERANCES	CHECKED <i>M. A. C.</i>
FRACTIONS DECIMALS ANGLES	ENGINEER <i>M. A. C.</i> 7/1/65
MATERIAL:	APPROVED
L/M:8	CONTRACT NO. REL. DATE
ASM-1	DESIGN ACTIVITY APPROVAL
NEXT ASSY USED ON	APPROVED
APPLICATION	

DELTA ELECTRONICS, INC. ALEXANDRIA, VIRGINIA			
DECODER ASSEMBLY			
CODE IDENT NO	SIZE	DRAWING NO.	REV.
19482	D	4D33-332	K
SCALE: NONE	SHEET 1 OF 1		

D95-768

4D33-332 K

SYM	ZONE	DESCRIPTION	DATE	APPROVED
SEE SHEET (O) OF 8033-328 FOR REVISIONS				

- NOTES: 1. UNLESS OTHERWISE SPECIFIED, ALL RESISTORS ARE IN OHMS, 1/4W, +/- 5%.
 2. UNLESS OTHERWISE SPECIFIED, ALL CAPACITORS ARE IN MICROFARADS, +/- 10%.
 3. TEST AND INSPECTION PROCEDURE: 7033-328
 4. U101 IS TL082CP, U102, U103 ARE MC1495L, U104-U106, U111-U113, U115 ARE TL084CN, U107-U110 ARE MC1455P1, U114 IS NE567N, U116 IS MC1741CP, U117 IS MC3302P.

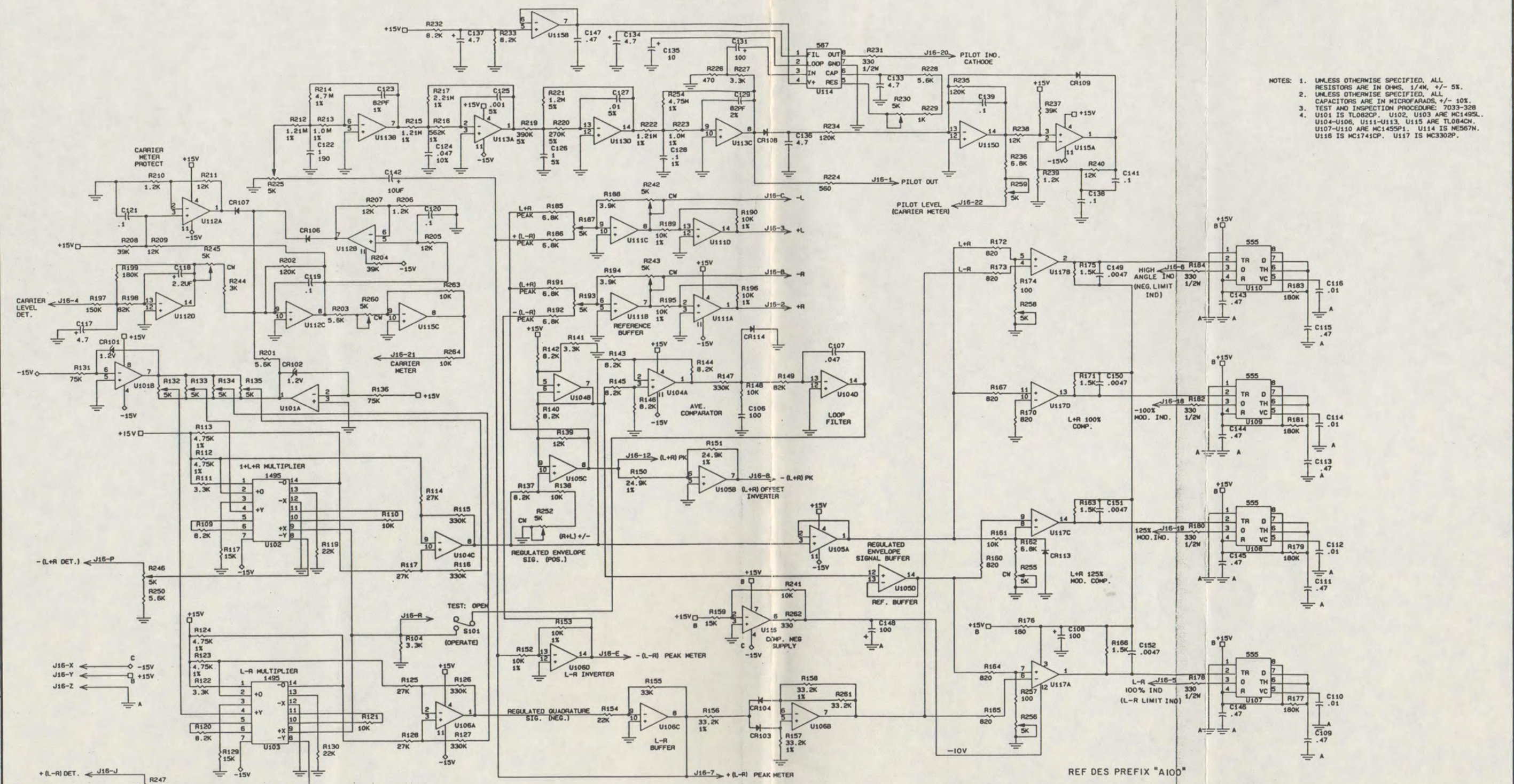

If You Didn't Get This From My Site,
 Then It Was Stolen From...
www.SteamPoweredRadio.Com

THESE DRAWINGS AND SPECIFICATIONS ARE THE PROPERTY OF DELTA ELECTRONICS, INC. AND SHALL NOT BE REPRODUCED OR COPIED OR USED AS THE BASIS FOR THE MANUFACTURE OR SALE OF APPARATUS WITHOUT PERMISSION.

UNLESS OTHERWISE SPECIFIED DIMENSIONS ARE IN INCHES	DRAWN <i>Deanna M. Payne</i> DATE 4/12/85	DELTA ELECTRONICS, INC. ALEXANDRIA, VIRGINIA	
TOLERANCES FRACTIONS DECIMALS ANGLES	CHECKED <i>M.A.C.</i>	AVC ASSEMBLY	
MATERIAL: L/M:8	ENGINEER <i>M.A.C.</i> 1/7/85	DESIGN ACTIVITY APPROVAL	CODE IDENT NO 19482
FINISH:	APPROVED	REL. DATE	SIZE D
NEXT ASSY USED ON	APPROVED	REL. DATE	DRAWING NO. 4D33-328
APPLICATION	APPROVED	REL. DATE	REV. <i>F</i>
		SCALE: NONE	SHEET 1 OF 1

4D33-328 F

REVISIONS				
SYM	ZONE	DESCRIPTION	DATE	APPROVED
SEE SHEET (O) OF BD33-329 FOR REVISIONS				

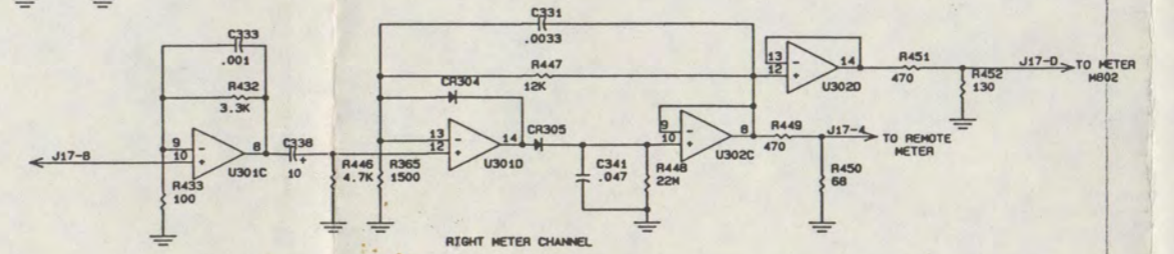
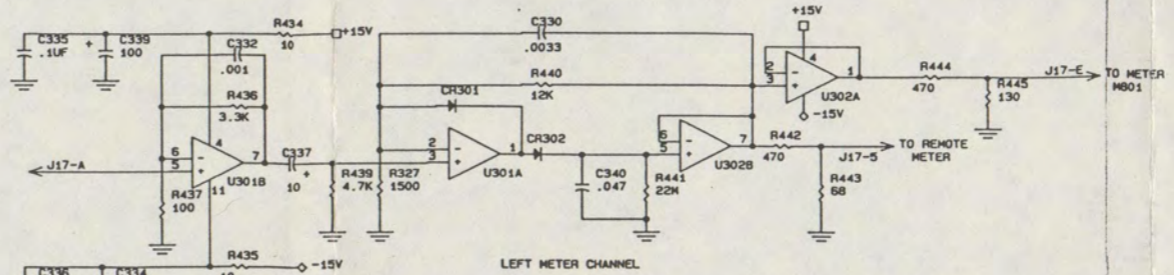
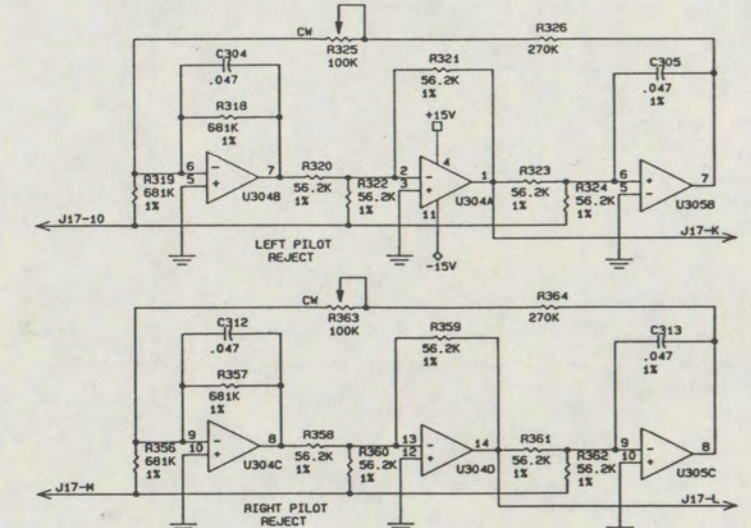

NOTES: 1. UNLESS OTHERWISE SPECIFIED, ALL RESISTORS ARE IN OHMS, 1/4W, +/- 5%.
 2. UNLESS OTHERWISE SPECIFIED, ALL CAPACITORS ARE IN MICROFARADS, +/- 10%.
 3. TEST AND INSPECTION PROCEDURE: 7D33-329.
 4. U301, U302, U304, U305, U309 ARE TL084CN. U303 IS TL082CP. U306 IS MC3302P. U307, U310 ARE MC1458P1.

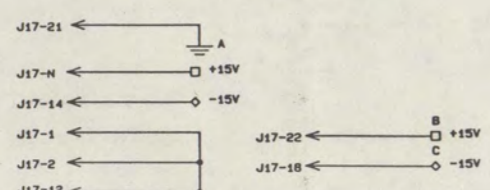
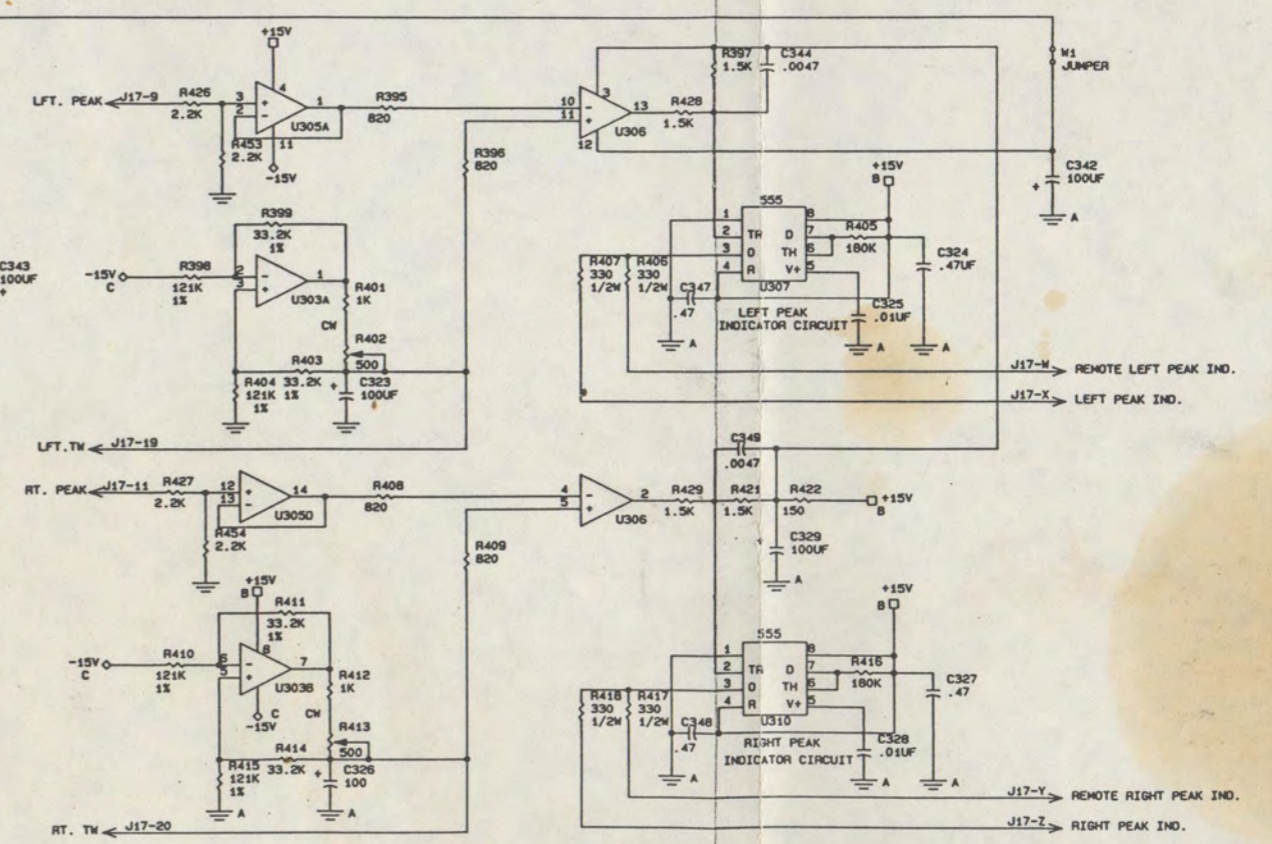
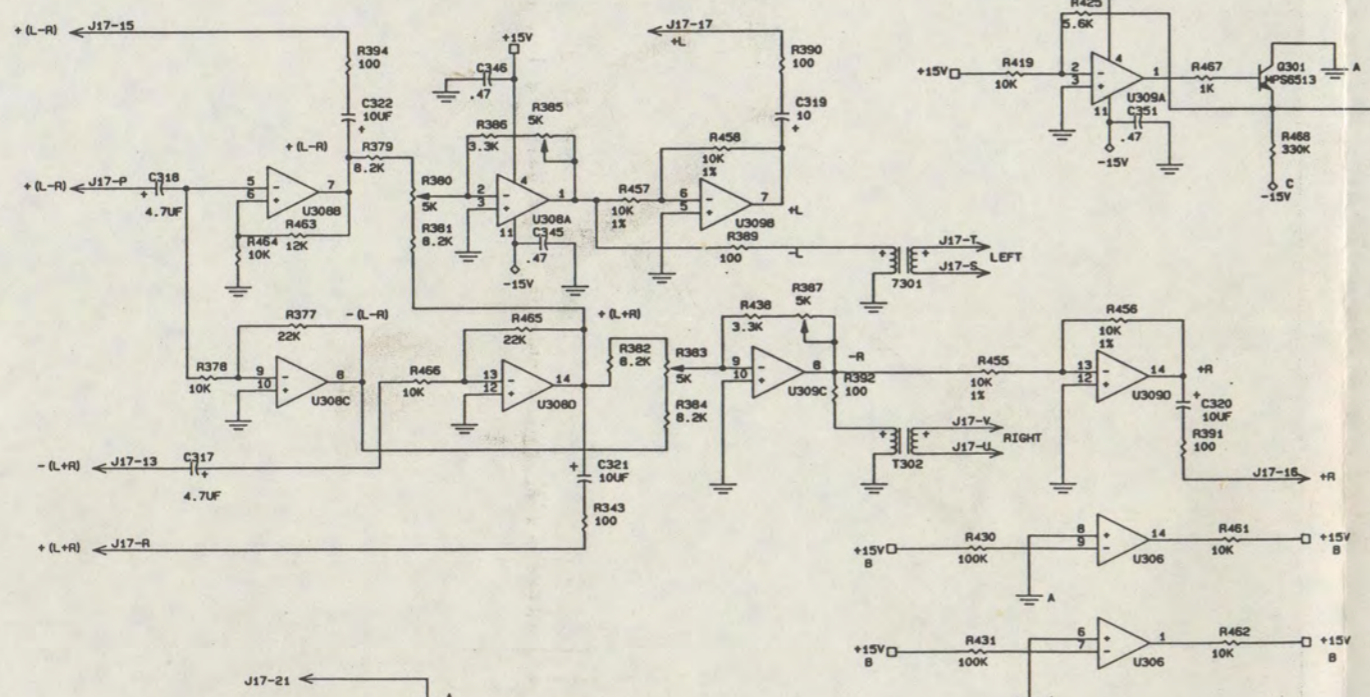

REF DES PREFIX "A300"

THESE DRAWINGS AND SPECIFICATIONS ARE THE PROPERTY OF DELTA ELECTRONICS, INC. AND SHALL NOT BE REPRODUCED OR COPIED OR USED AS THE BASIS FOR THE MANUFACTURE OR SALE OF APPARATUS WITHOUT PERMISSION.

UNLESS OTHERWISE SPECIFIED DIMENSIONS ARE IN INCHES		DRAWN <i>mcc</i> DATE 4/2/85		DELTA ELECTRONICS, INC. ALEXANDRIA, VIRGINIA	
TOLERANCES FRACTIONS DECIMALS ANGLES		CHECKED <i>P.A.C.</i>	ENGINEER <i>P.A.C.</i> 4/1/85	METER CONTROL ASSEMBLY	
MATERIAL: L/M:8		APPROVED <i>T.W.</i> 4/2/85	CONTRACT NO.	REL. DATE	DESIGN ACTIVITY APPROVAL
ASM - I	FINISH:	DESIGN ACTIVITY APPROVAL		CODE IDENT NO	SIZE
NEXT ASSY USED ON	APPLICATION	APPROVED	APPROVED	19482	D
				4D33-329	REV. F
				SCALE: NONE	SHEET 1 OF 1

If You Didn't Get This From My Site,
 Then It Was Stolen From...
www.SteamPoweredRadio.Com

4D33-329 F

REVISIONS			
SYM	ZONE	DESCRIPTION	DATE APPROVED
SEE SHEET (O) OF 8033-330 FOR REVISIONS			

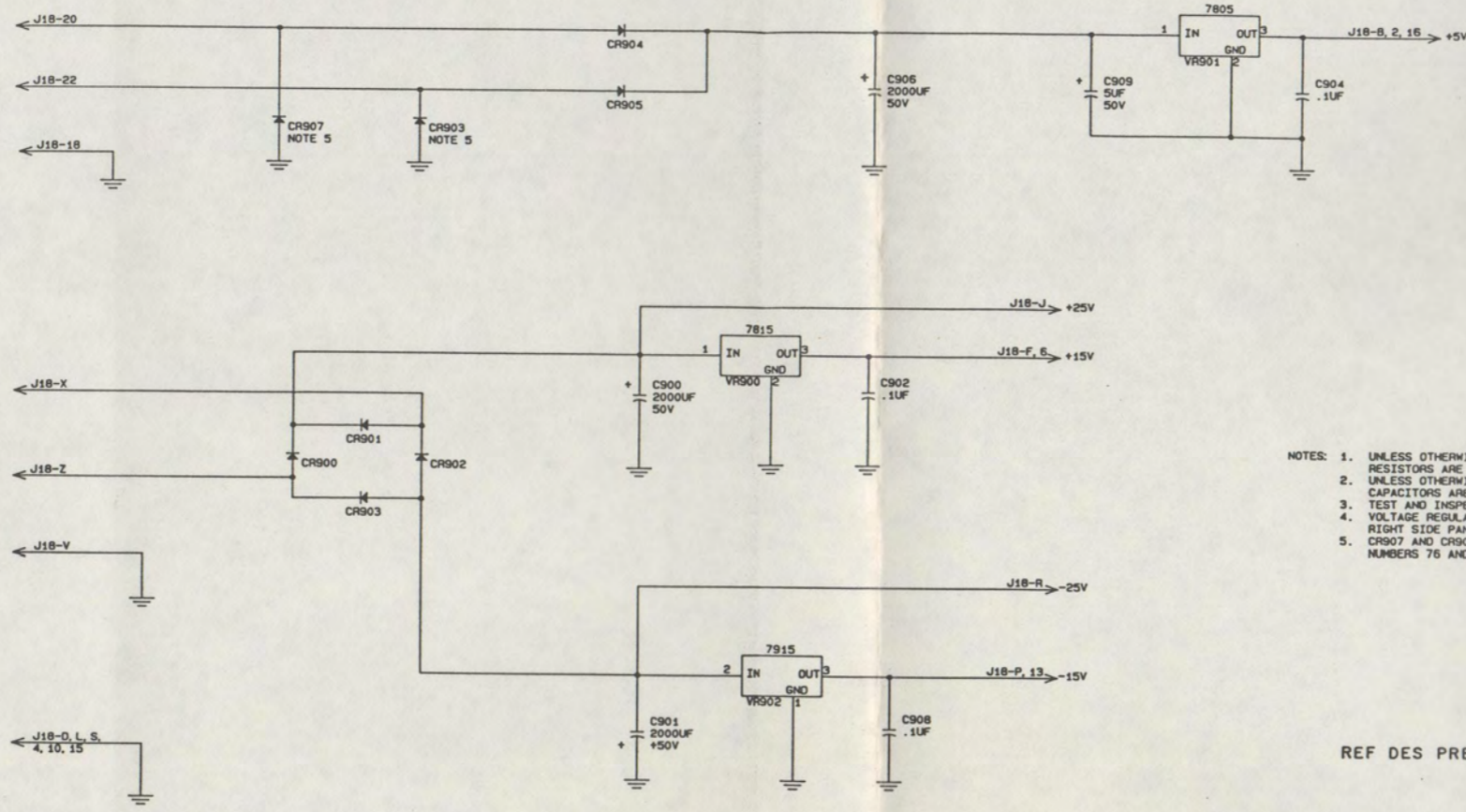

- NOTES:
1. UNLESS OTHERWISE SPECIFIED, ALL RESISTORS ARE IN OHMS; 1/4W, +/- 5%.
 2. UNLESS OTHERWISE SPECIFIED, ALL CAPACITORS ARE IN MICROFARADS +/- 10%.
 3. TEST AND INSPECTION PROCEDURE: 7033-330.
 4. VOLTAGE REGULATORS ARE MOUNTED ON RIGHT SIDE PANEL HEATSINK.
 5. CR907 AND CR908 INSTALLED FOR SERIAL NUMBERS 76 AND ABOVE.

REF DES PREFIX "A900"

4D33-330 G

UNLESS OTHERWISE SPECIFIED DIMENSIONS ARE IN INCHES		DRAWN <i>McCole</i> DATE <i>3/2/85</i>		DELTA ELECTRONICS, INC. ALEXANDRIA, VIRGINIA	
TOLERANCES FRACTIONS DECIMALS ANGLES		CHECKED <i>M.A.C.</i>		POWER SUPPLY ASSEMBLY	
		ENGINEER <i>M.A.C.</i> <i>4/2/85</i>			
		APPROVED <i>T.M.</i> <i>4/2/85</i>		CODE IDENT NO. SIZE DRAWING NO. REV.	
		CONTRACT NO. REL. DATE		19482 D 4D33-330 1	
		DESIGN ACTIVITY APPROVAL		SCALE: NONE SHEET 1 OF 1	
MATERIAL: L/M:8		FINISH:			
NEXT ASSY USED ON APPLICATION		APPROVED			

THESE DRAWINGS AND SPECIFICATIONS ARE THE PROPERTY OF DELTA ELECTRONICS, INC. AND SHALL NOT BE REPRODUCED, OR COPIED, OR USED AS THE BASIS FOR THE MANUFACTURE OR SALE OF APPARATUS WITHOUT PERMISSION.

If You Didn't Get This From My Site,
Then It Was Stolen From...
www.SteamPoweredRadio.Com

D93-768

APPENDIX A

FCC SECTION(S)

74.40 AND 73.128

APPENDIX B
ASE-1/ASM-1 EQUIPMENT
PERFORMANCE MEASUREMENT
SAMPLE FORMS

L + R

Exciter to Monitor Closed Loop Checkout L + R Performance

Exciter Serial _____
 Monitor Serial _____
 Radio Station _____
 Date _____

Frequency, Hz.	50	100	400	1k	5k	7½k	10k	12½k	15k
L + R Frequency Response 95% Modulation				0 dB					
L + R Distortion 95% Modulation									
L + R into L - R Crosstalk (IPM)									
L + R Noise Level									

L + R

Exciter to Monitor Closed Loop Checkout L + R Performance

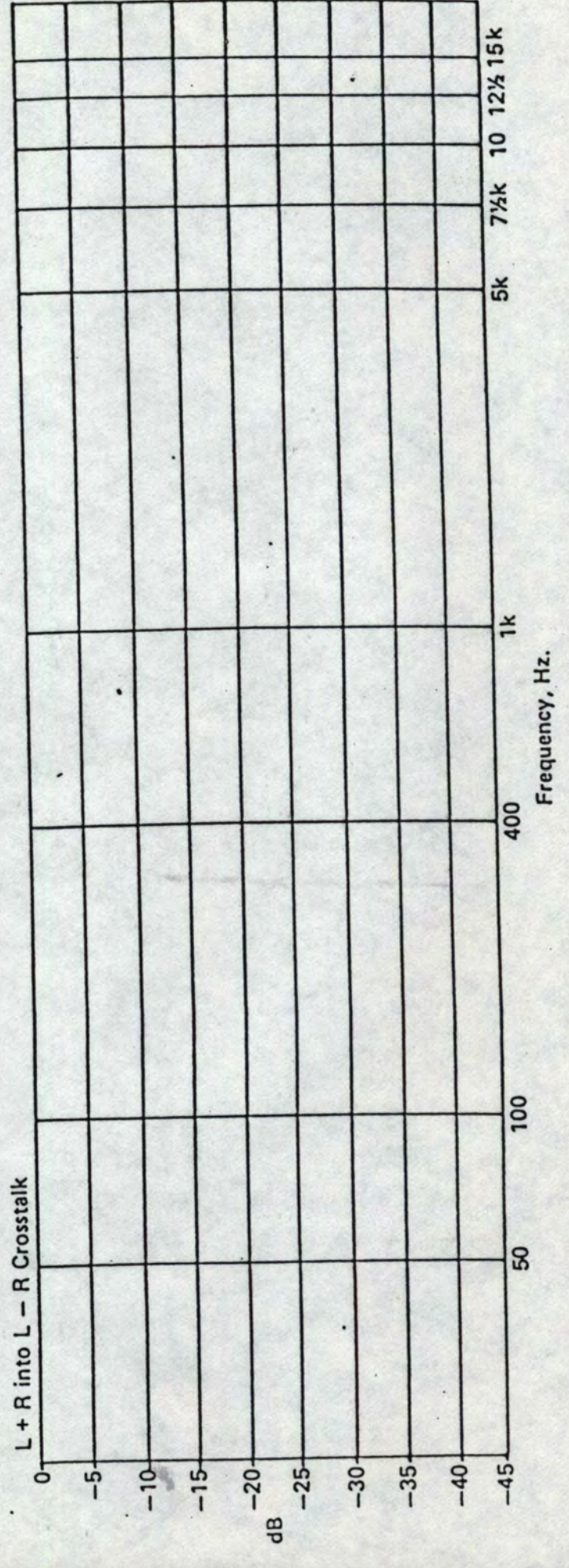
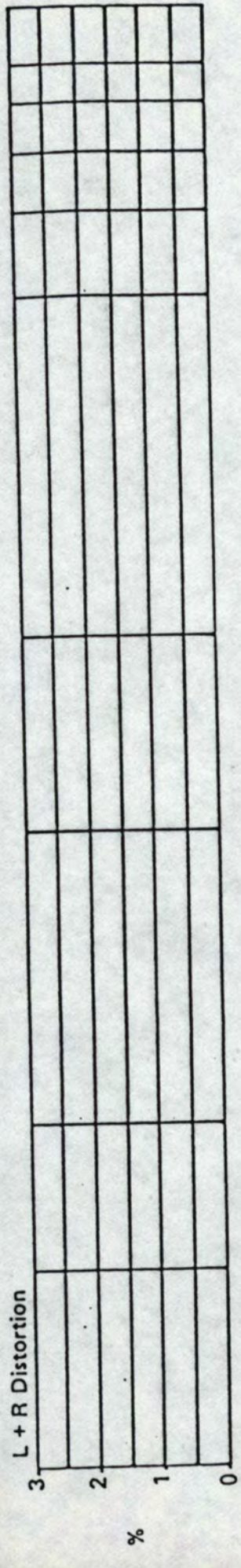
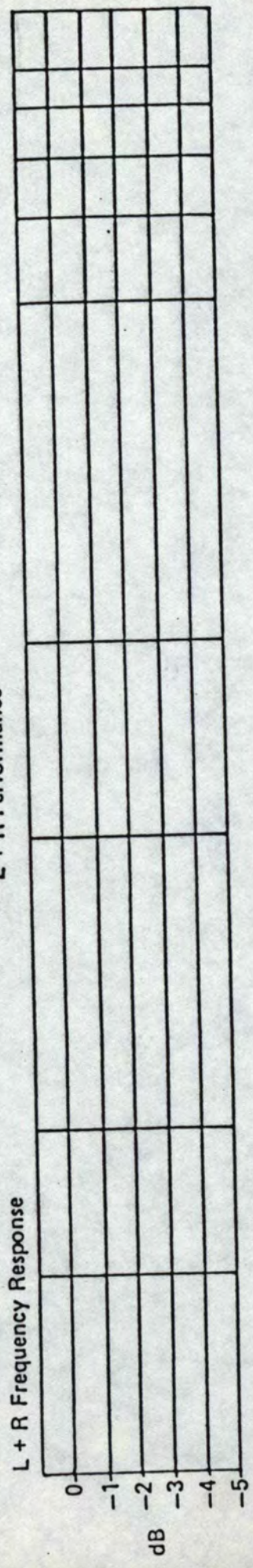

L - R

Exciter to Monitor Closed Loop Checkout L - R Performance

Exciter Serial _____
Monitor Serial _____
Radio Station _____
Date _____

Frequency, Hz.	50	100	400	1k	5k	7½k	10k	12½k	15k
L - R Frequency Response, 95% Modulation				0 dB					
L - R Distortion 95% Modulation									
L - R into L + R Crosstalk, (Incidental Amplitude Modulation)									
L - R Noise Level									

L - R Frequency Response,
95% Modulation

L - R Distortion
95% Modulation

L - R into L + R Crosstalk,
(Incidental Amplitude
Modulation)

L - R Noise Level

Exciter to Monitor Closed Loop Checkout
L - R Performance

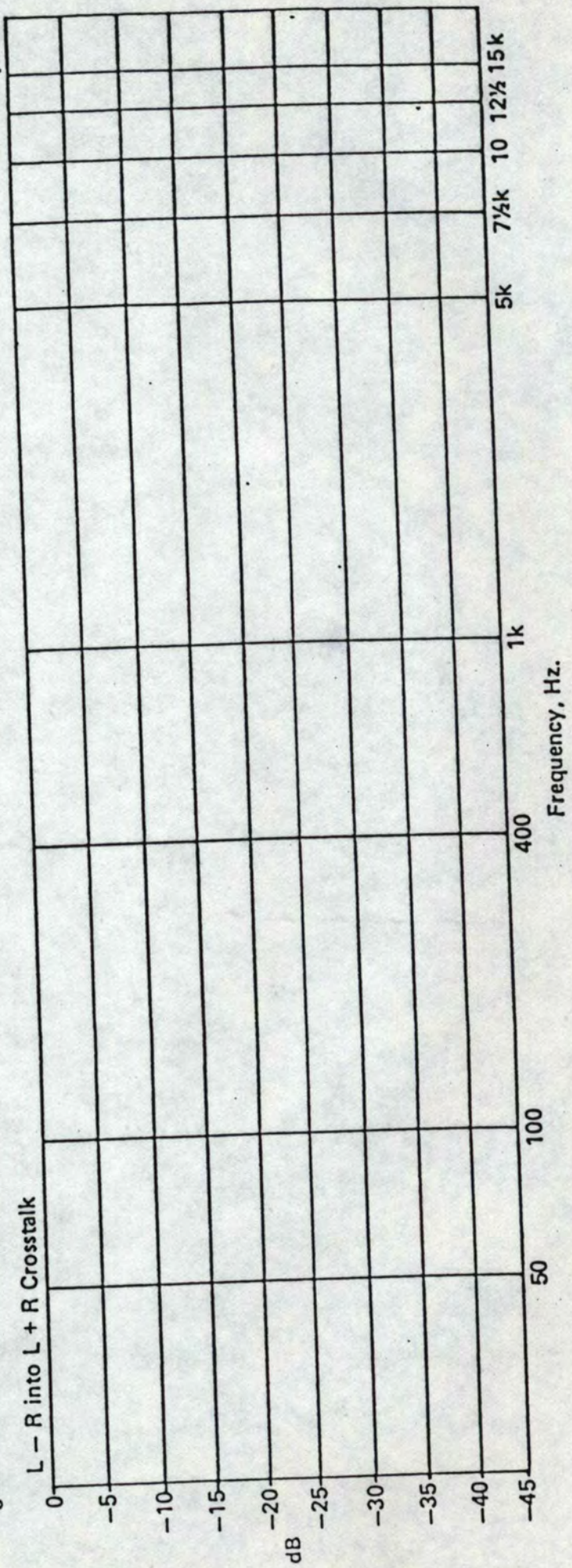
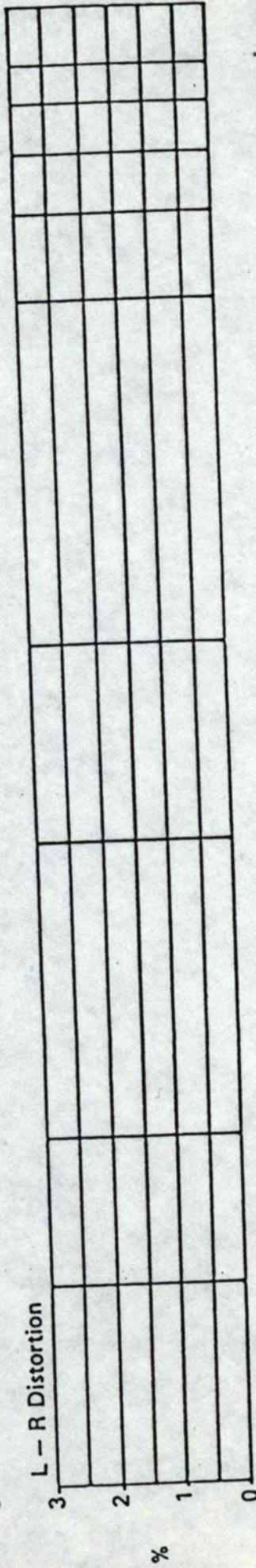
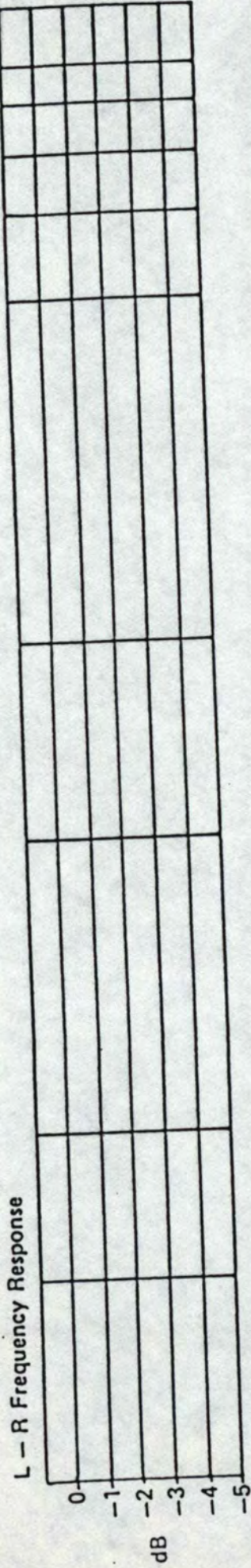

Exciter to Monitor Closed Loop Checkout Right Channel Performance

Exciter Serial _____
 Monitor Serial _____
 Radio Station _____
 Date _____

Frequency, Hz.	50	100	400	1k	5k	7½k	10k	12½k	15k
Right Channel Audio Frequency Response, 50% Modulation				0 dB					
Right Channel Distortion 50% Modulation									
Right Channel into Left Separation, 50% Modulation									
Right Channel Noise Level									

Right Channel Audio Frequency Response, 50% Modulation

Right Channel Distortion 50% Modulation

Right Channel into Left Separation, 50% Modulation

Right Channel Noise Level

Exciter Serial _____
 Monitor Serial _____
 Radio Station _____
 Date _____

Exciter to Monitor Closed Loop Performance
 Left Channel Performance

Left

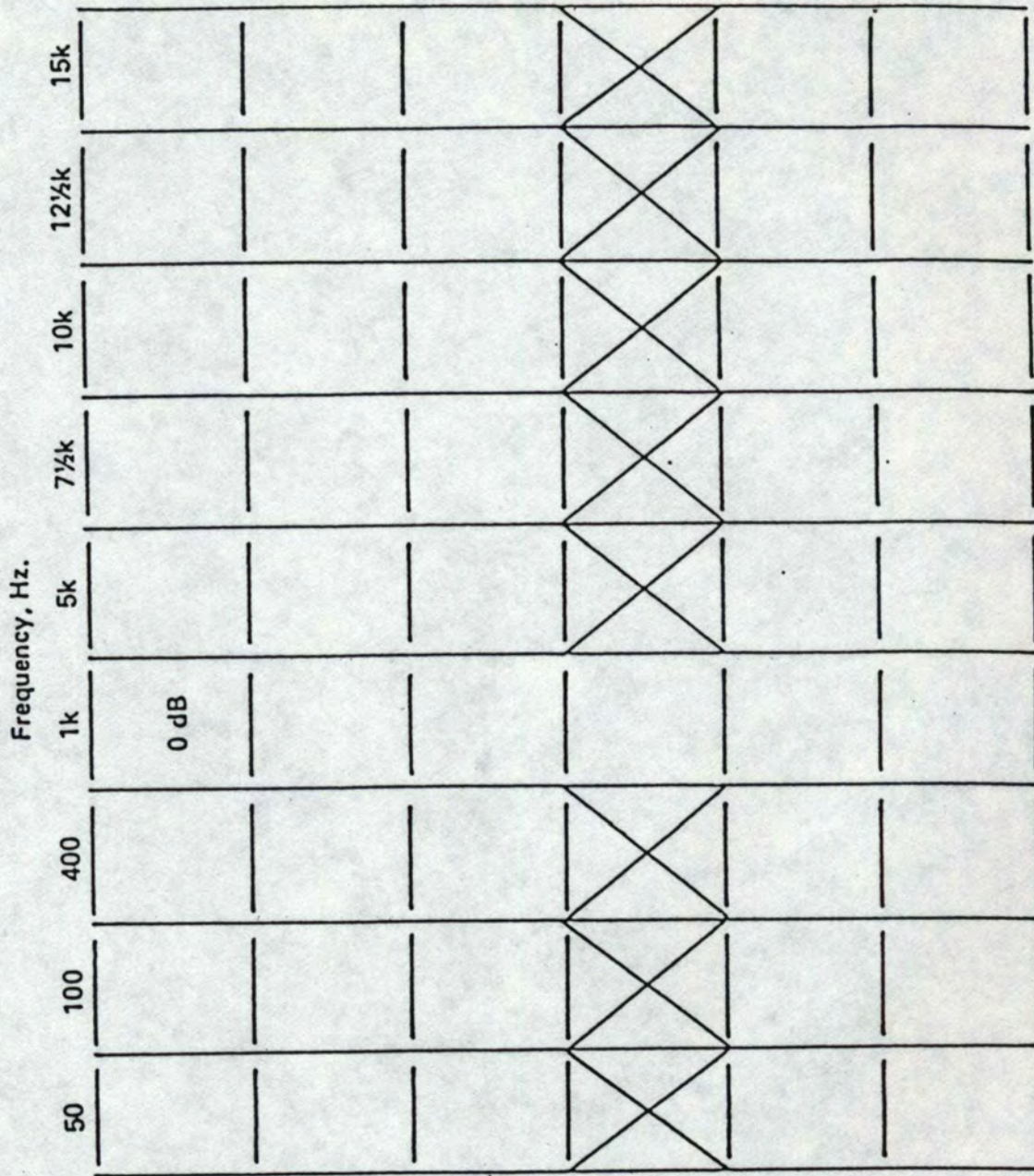

Left Channel Frequency Response, 50% Modulation

Left Channel Distortion 50% Modulation

Left Channel into Right, Separation, 50% Modulation

Left Channel Noise Level

Radio Station _____
Date _____

www.SteamPoweredRadio.Com
L + R
25% MODULATION

L + R
25%

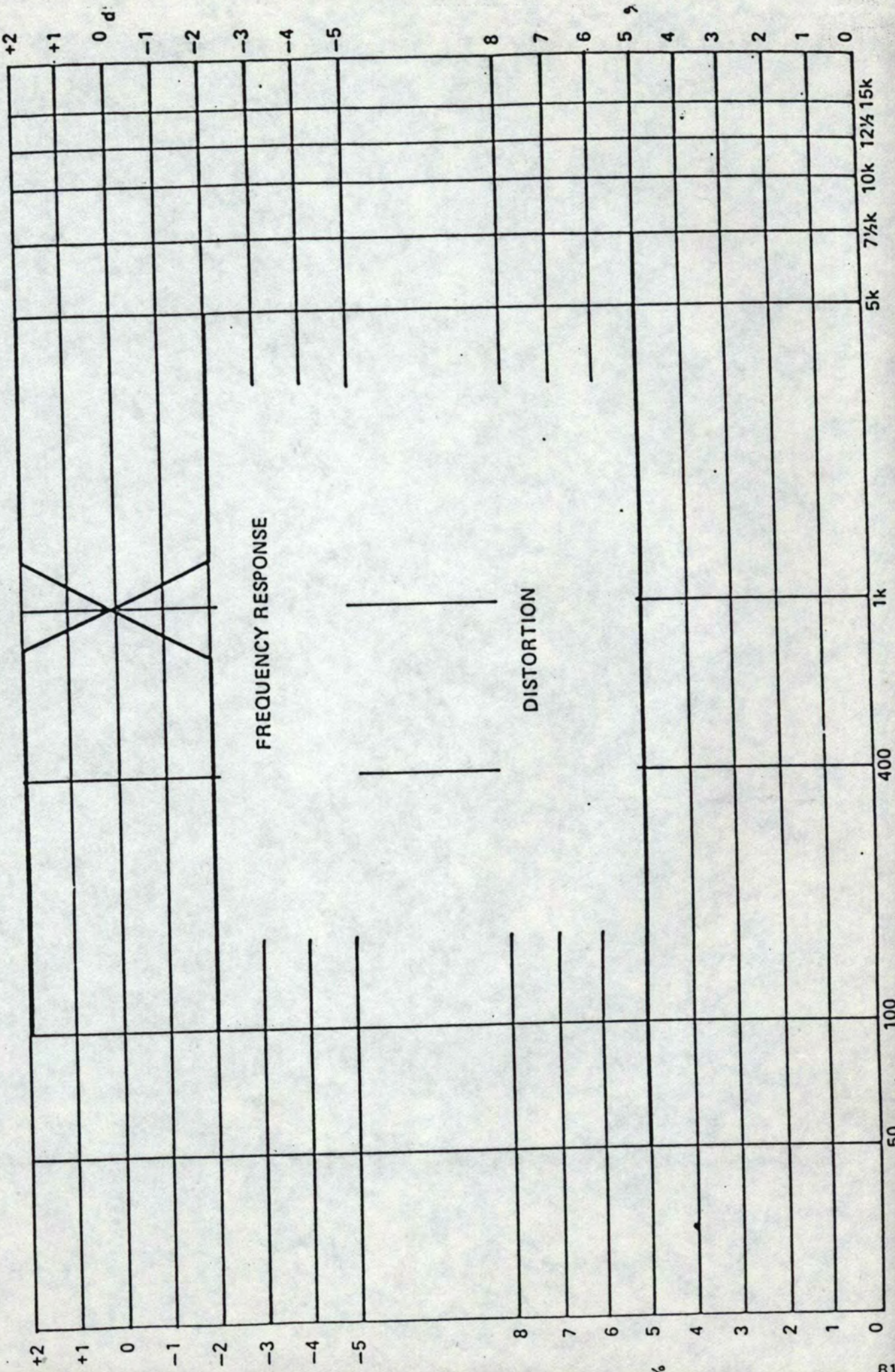

EQUIPMENT PERFORMANCE MEASUREMENT'S
TABULATION OF DATA

Station _____
Date _____

Audio Frequency Response & Distortion

	50	100	400	1k	5k	7½k	10k	12½k	15k
Response				0 dB					
Left, 75% Modulation* (± 2 dB, 100 - 5k)				0 dB					
Left, 50% Modulation (± 2 dB, 100 - 5k)				0 dB					
Left, 25% Modulation (± 2 dB, 100 - 5k)				0 dB		*	*	*	*
Distortion						*	*	*	*
Left, 75% Modulation* (5%)						*	*	*	*
Left, 50% Modulation (5%)									
Left, 25% Modulation (5%)									

* When attainable

Radio Station _____
Date _____

www.SteamPoweredRadio.Com
LEFT CHANNEL
75% MODULATION

Left
75%

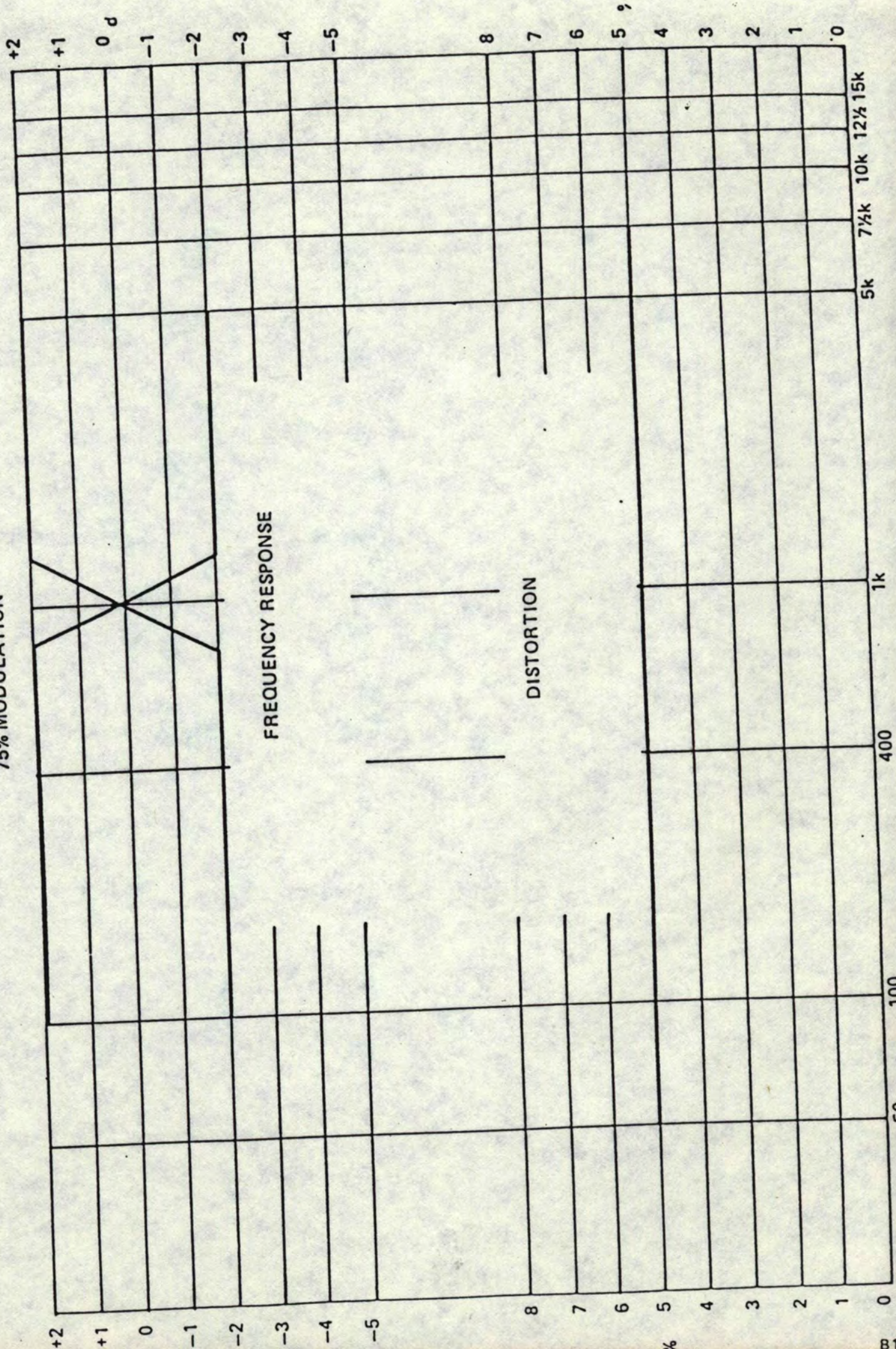

Date

LEFT CHANNEL
50% MODULATION

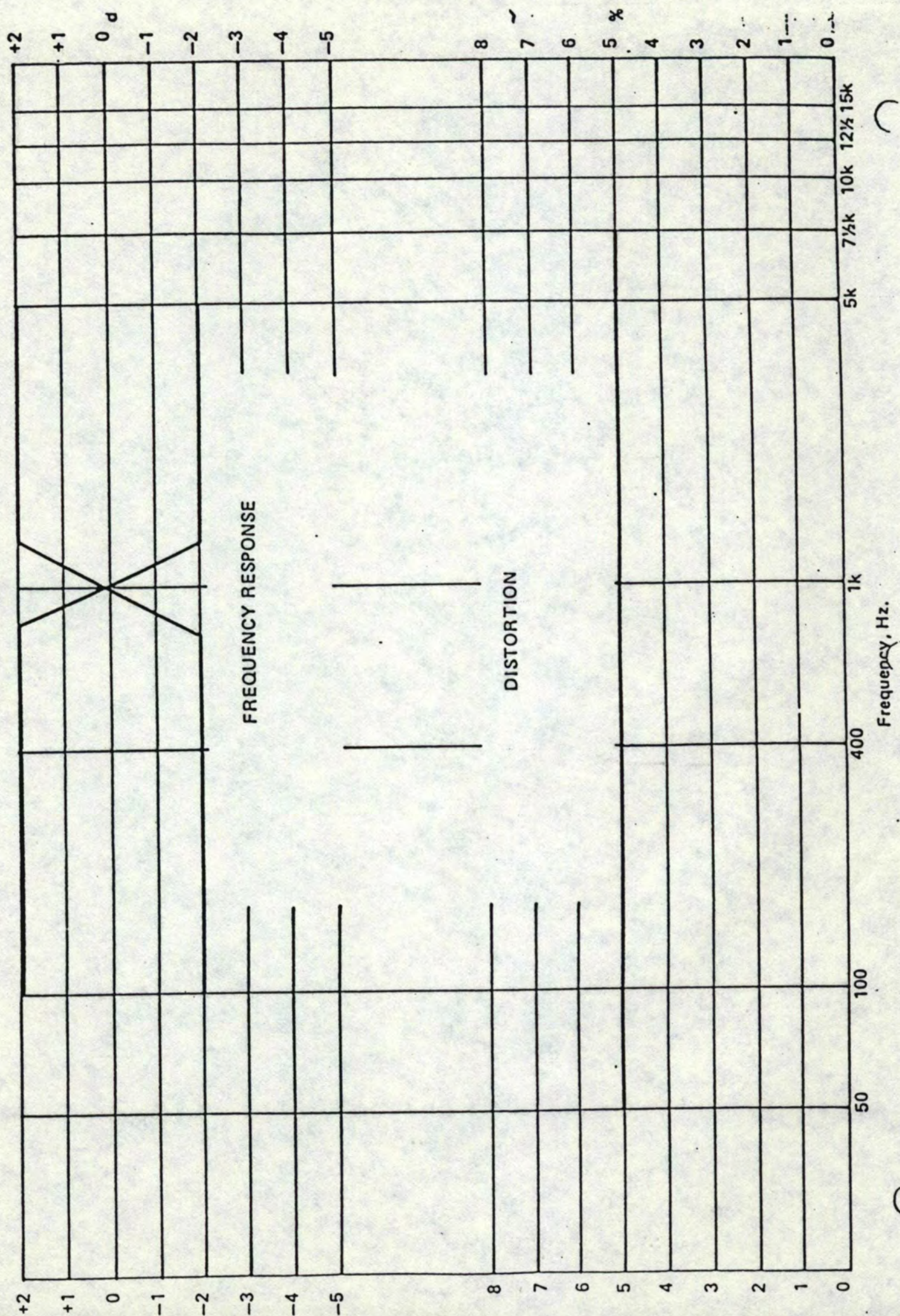

Radio Station _____
Date _____

www.SteamPoweredRadio.Com
LEFT CHANNEL
25% MODULATION

Left
25%

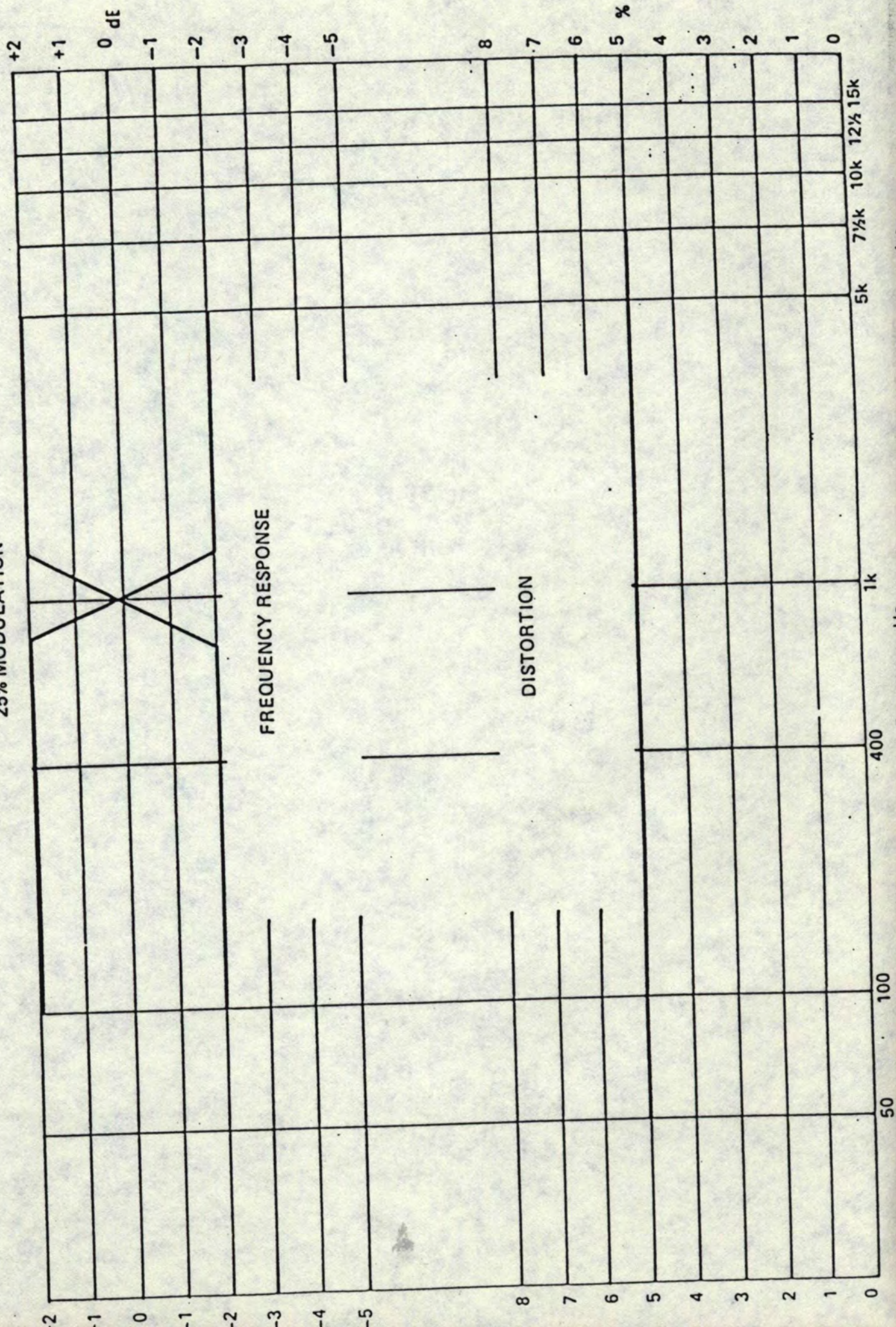

EQUIPMENT PERFORMANCE MEASUREMENTS
TABULATION OF DATA

Station _____
Date _____

Right
Audio Frequency Response & Distortion

	50	100	400	1k	5k	7½k	10k	12½k	15k
Right, 75% Modulation* (± 2 dB, 100 - 5k)				0 dB					
Right, 50% Modulation (± 2dB, 100 - 5k)				0 dB					
Right, 25% Modulation (± 2 dB, 100 - 5k)				0 dB		*	*	*	*
Distortion									
Right, 75% Modulation* (5%)							*	*	*
Right, 50% Modulation (5%)									
Right, 25% Modulation (5%)							*	*	*

Date _____

RIGHT INTO LEFT

50% MODULATION

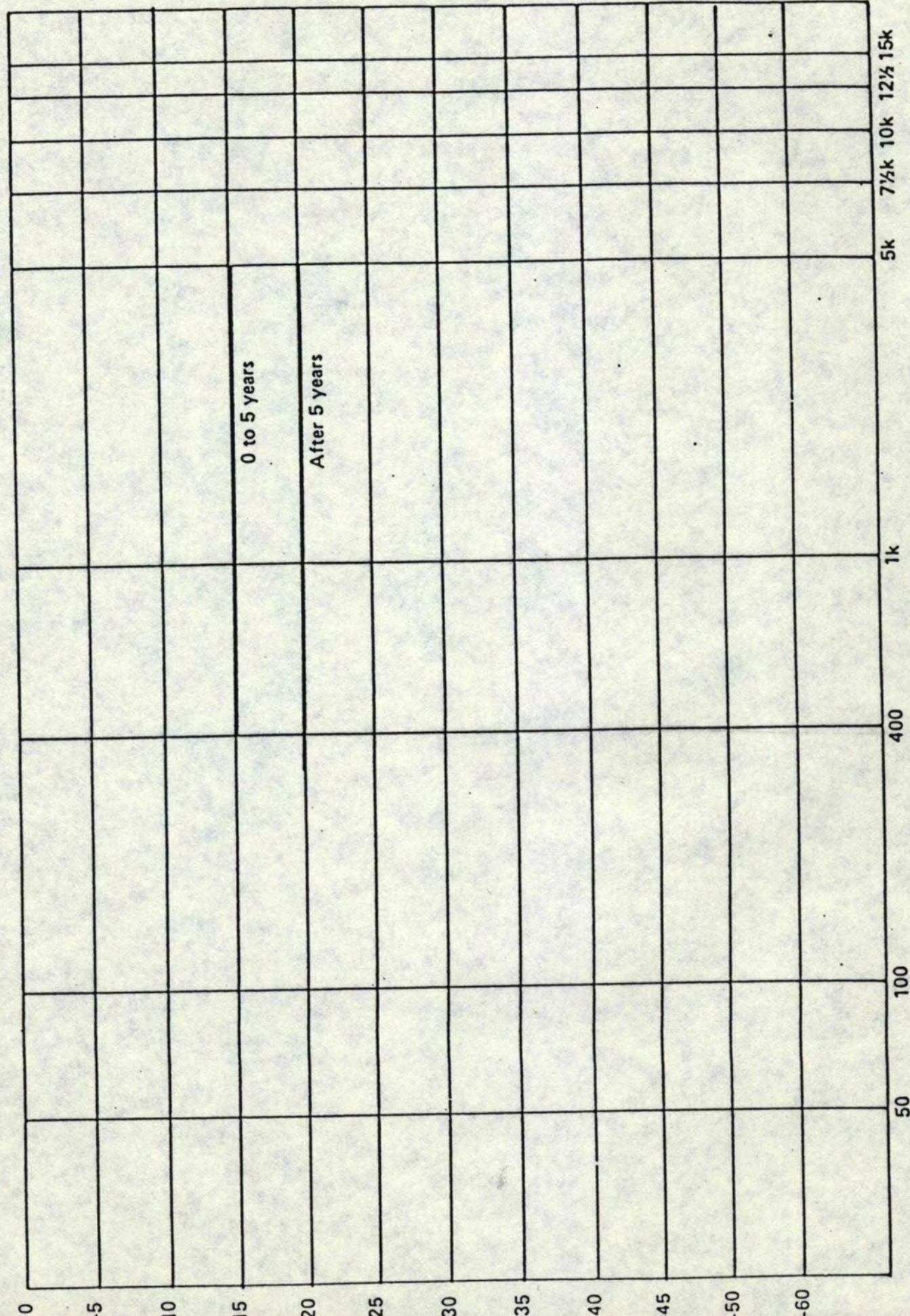

Frequency, Hz.

EQUIPMENT PERFORMANCE MEASUREMENTS
TABULATION OF DATA

L+R to L-R
&
L-R to L+R
Crosstalk

Station _____

Date _____

Frequency, Hz.	50	100	400	1k	5k	7½k	10k	12½k	15k
Main to Subchannel Crosstalk in dB (No Specification) 95% L+R Modulation									
Incidental Phase Modulation Same as above, expressed in Radians. No Specification 95% L+R Modulation									
Subchannel to Main Crosstalk No Specification 95% L-R Modulation									

on

Date _____

(ALSO)

INCIDENTAL PHASE MODULATION
L + R, 95% MODULATION

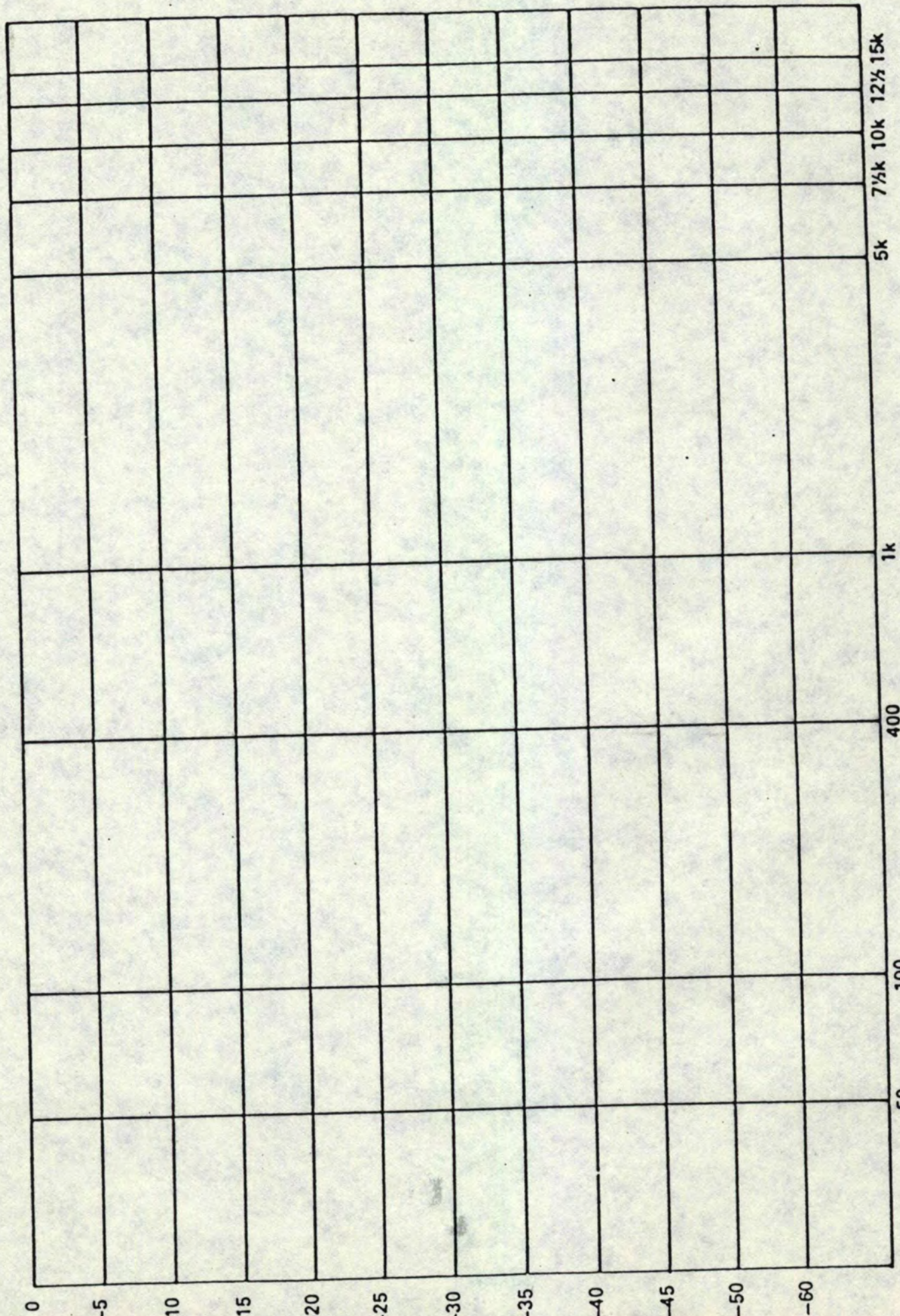

Frequency, Hz.

Station _____
Date _____

SUBCHANNEL TO MAIN CROSSTALK

L - R, 95% MODULATION

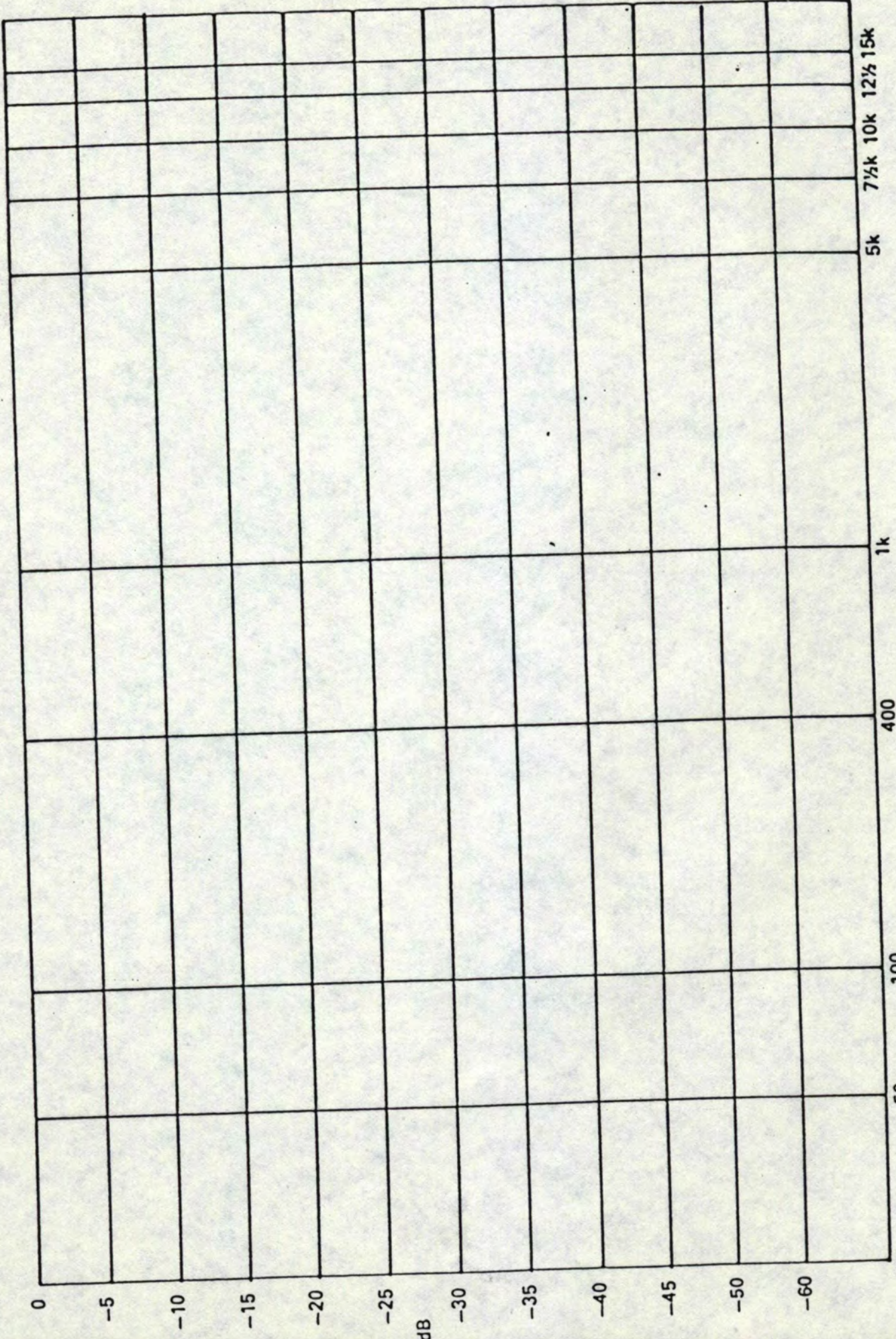

EQUIPMENT PERFORMANCE MEASUREMENTS

TABULATION OF DATA

Station _____

Date _____

Carrier Shift

L + R, 100% Modulation _____ %
L + R, 85% Modulation _____ %
L + R, 50% Modulation _____ %
L + R, 25% Modulation _____ %

Noise Level

Below 100% at 400 Hz.

L + R _____ dB

Left _____ dB

Right _____ dB

Harmonic and Spurious Observations,
L + R, L - R, Left, & Right _____

Broadcast Transmitter Worksheet

Radio Station _____
 Day _____ Date _____
 Xmtr _____ Power _____ Load: Dummy _____ Day _____ Night _____

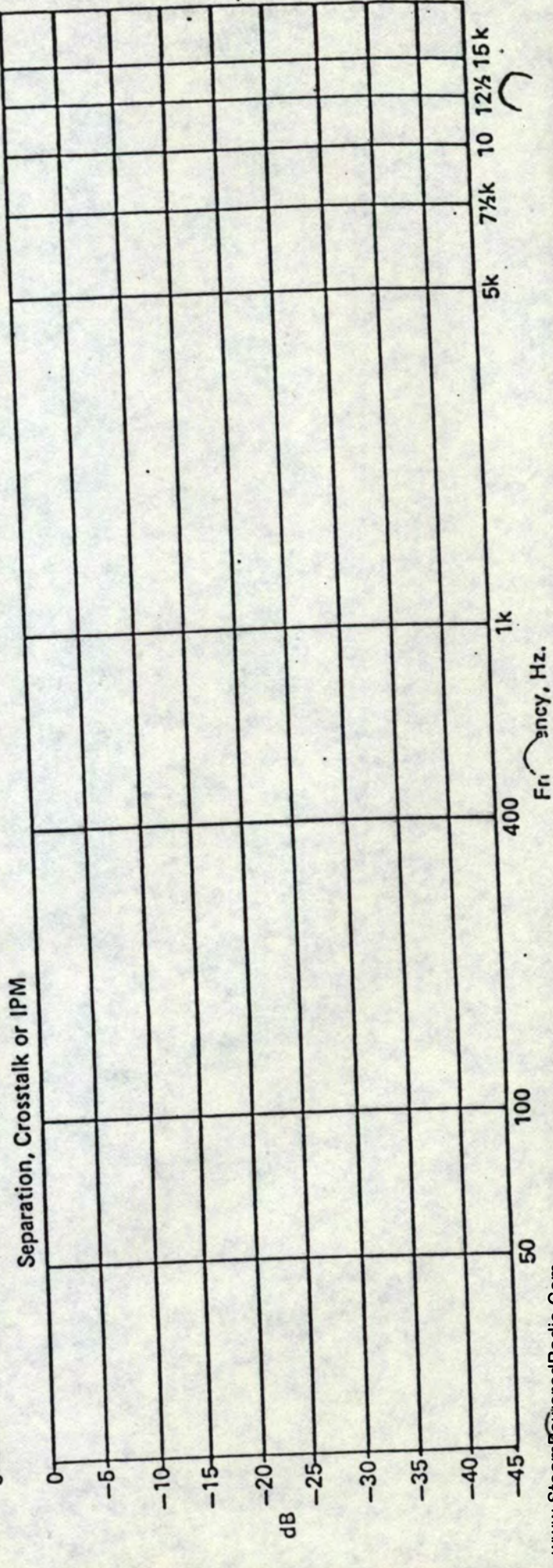
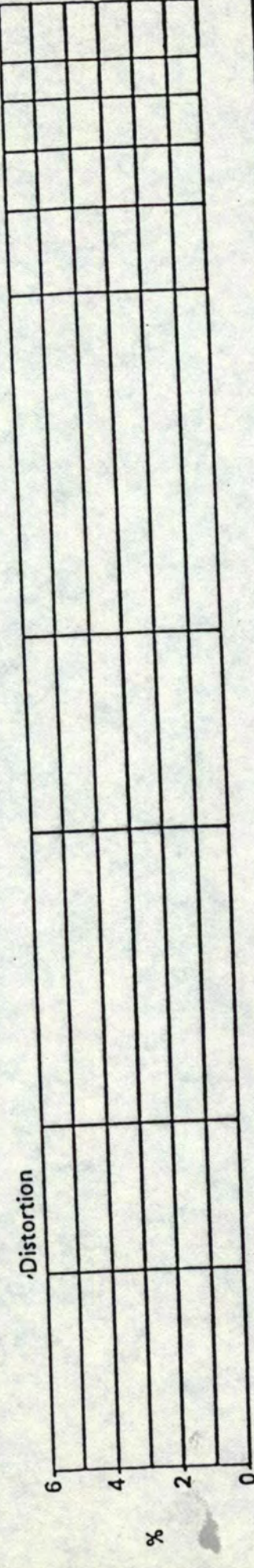
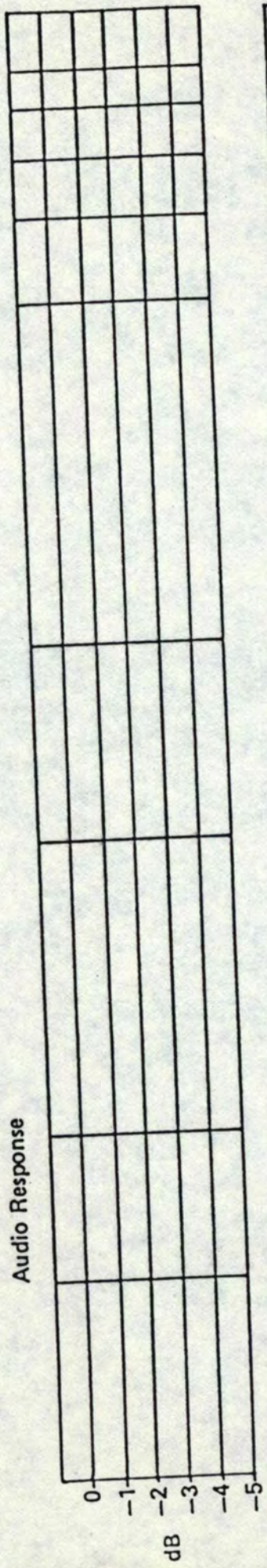

Radio Station _____

Date _____

Right
75%

RIGHT CHANNEL 75% MODULATION

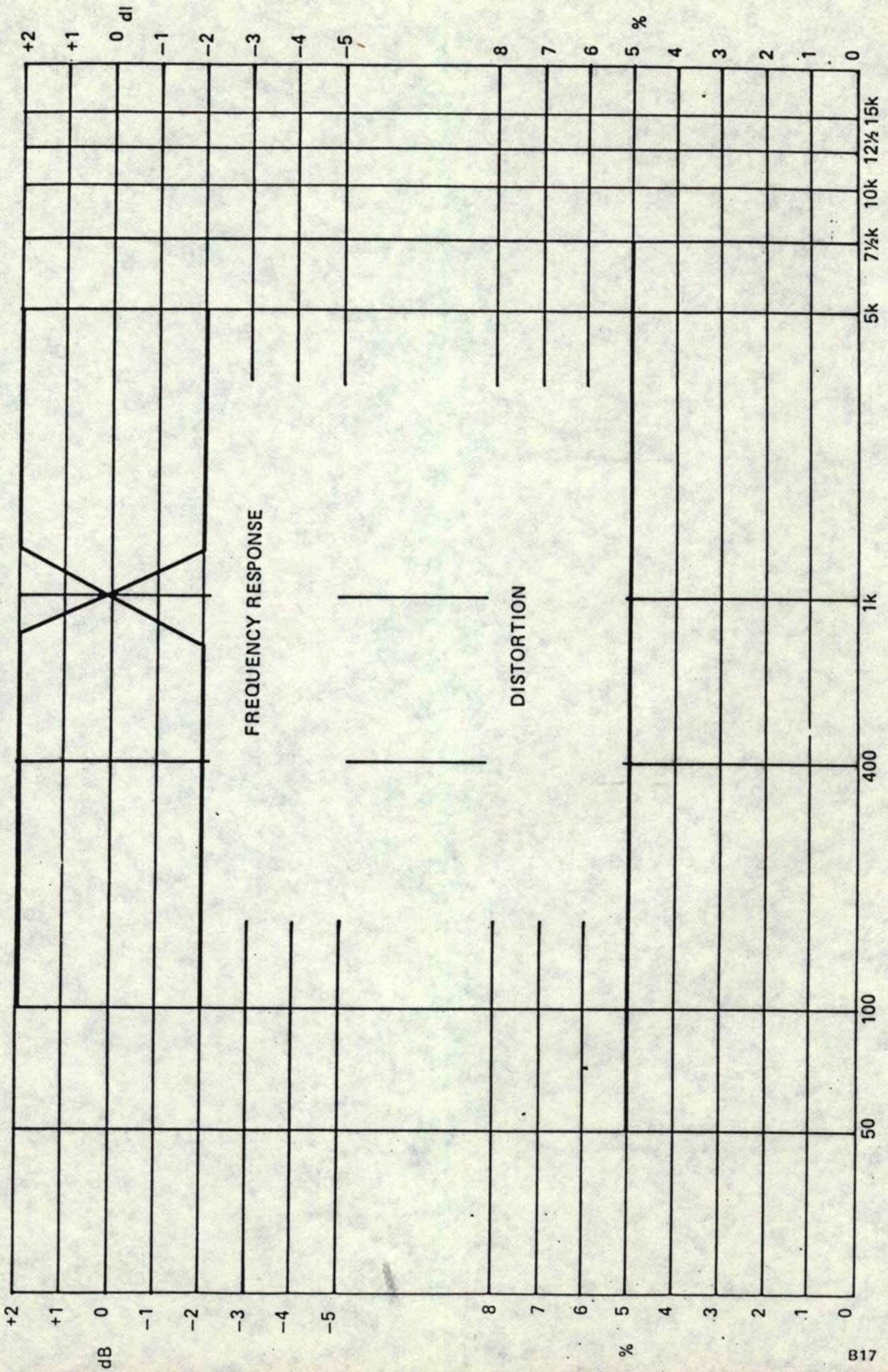

Date _____

RIGHT CHANNEL 50% MODULATION

Right
50%

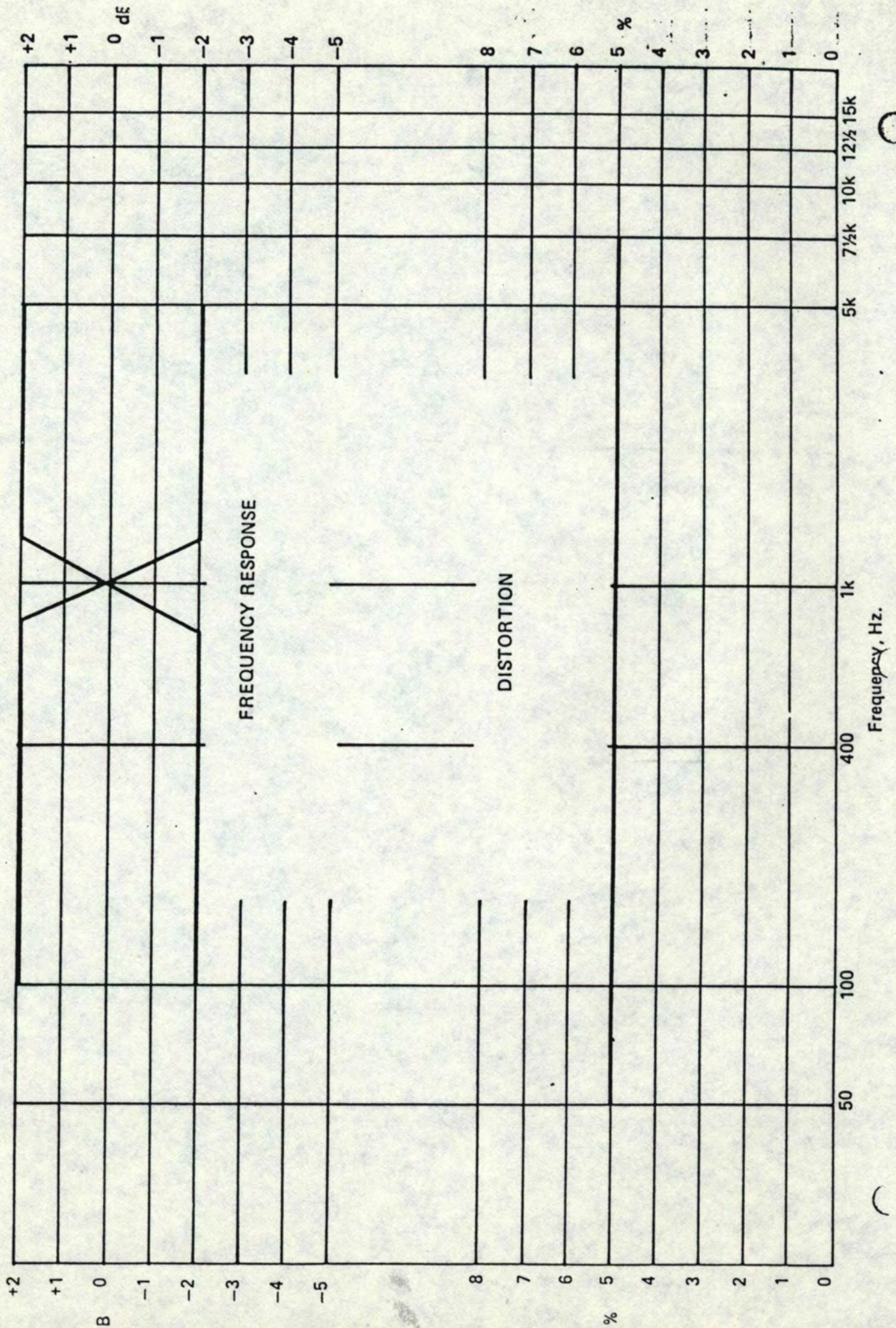

RIGHT CHANNEL 25% MODULATION

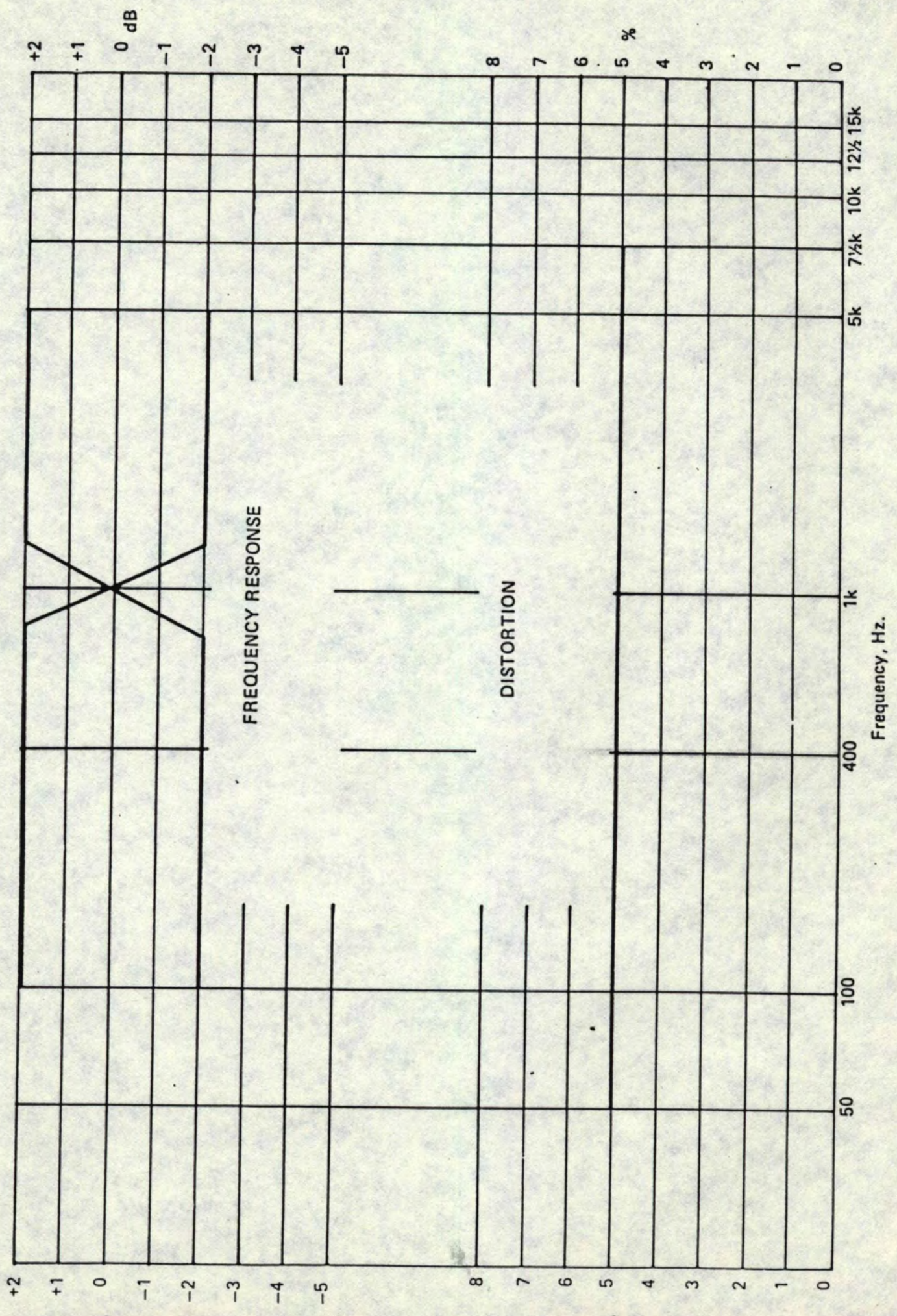

EQUIPMENT PERFORMANCE MEASUREMENTS TABULATION OF DATA

Station _____

Date _____

Separation
50% Modulation

50													
100													
400													
1k													
5k													
7½k													
10k													
12½k													
15k													

Separation, Left into Right
50% Modulation

Separation, Right into Left
50% Modulation

Station _____
Date _____

SEPARATION
LEFT INTO RIGHT
50% MODULATION

Separation

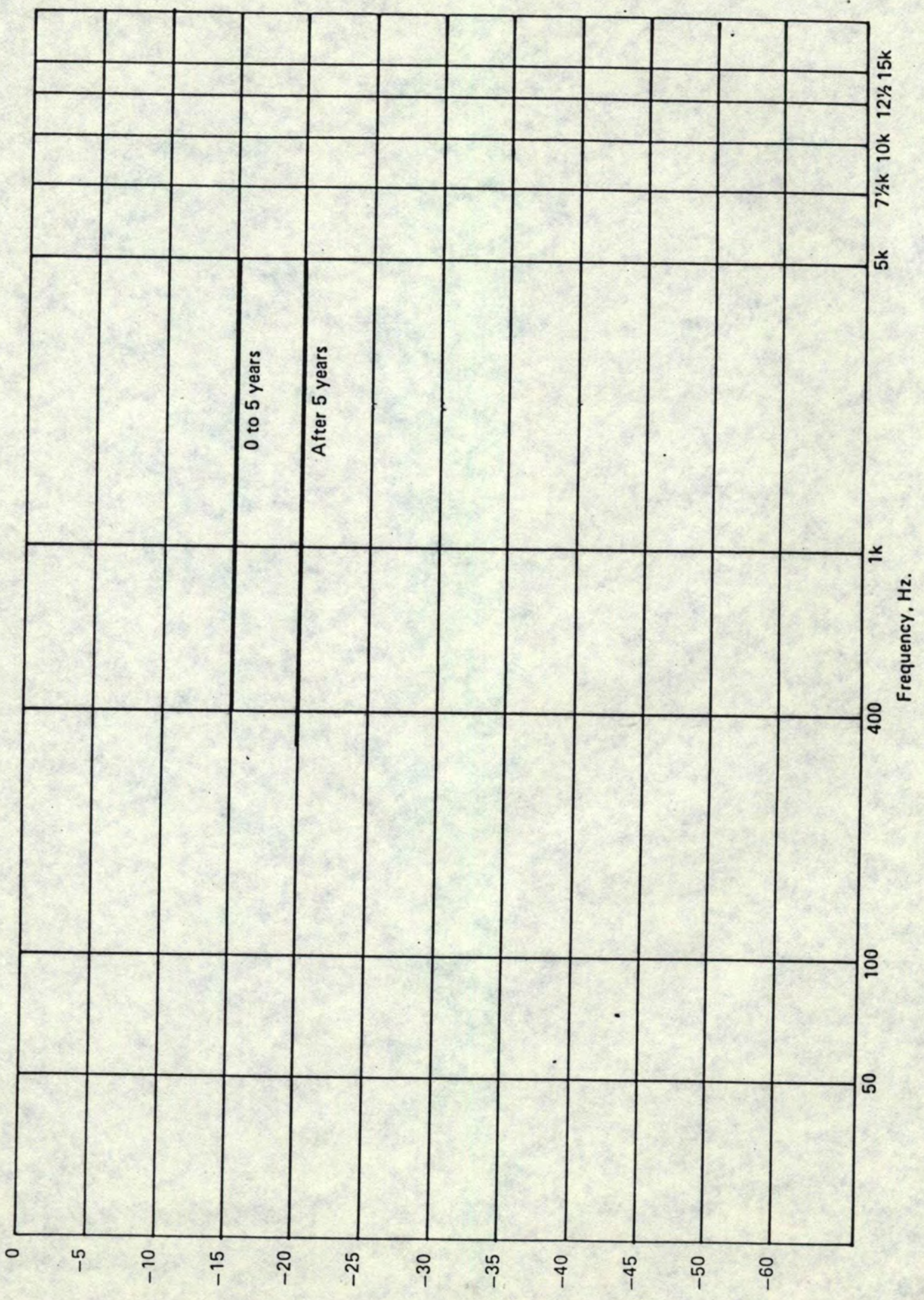

50% MODULATION

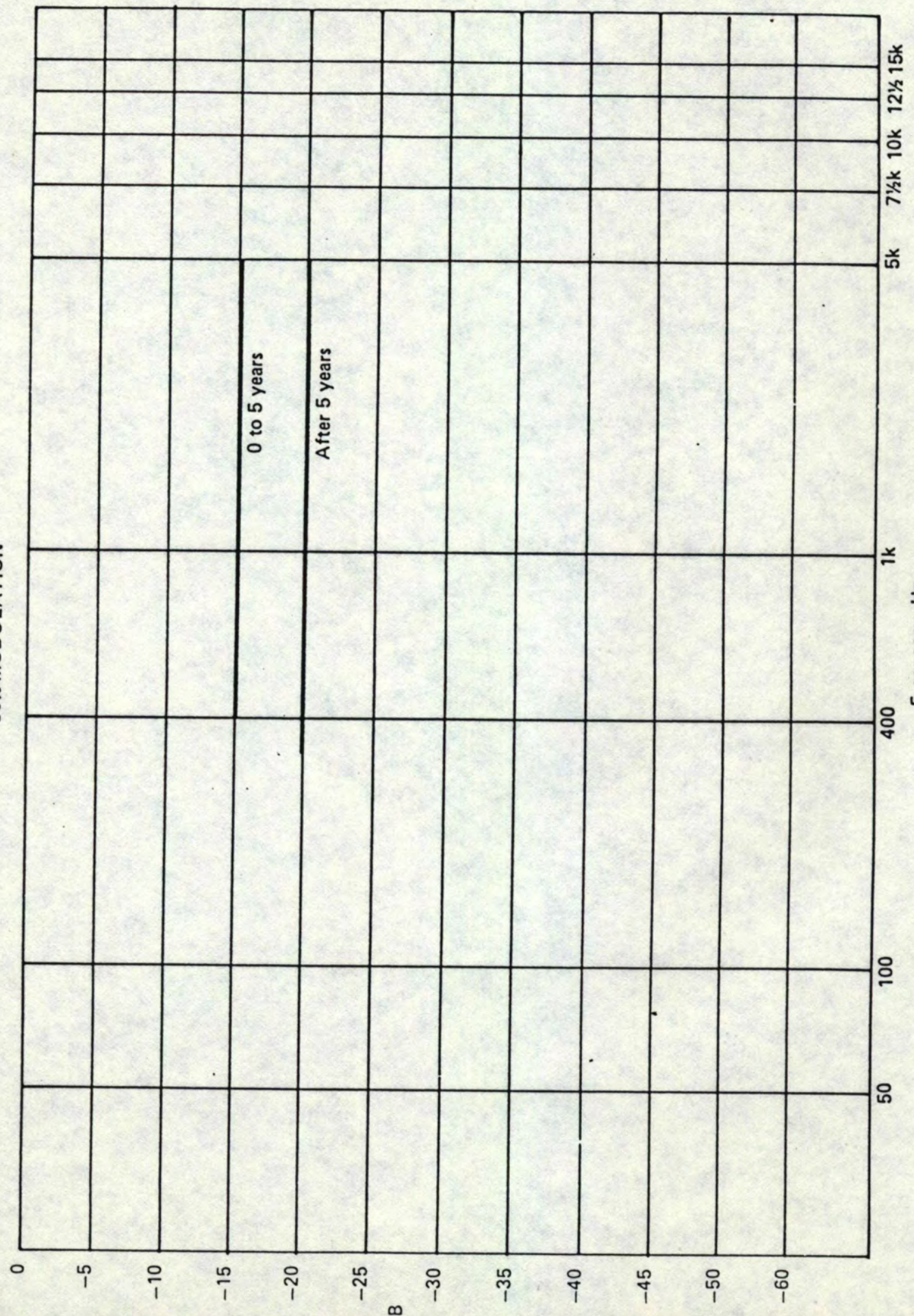

IPM
L+R to L-R
&
L-R to L+R
Crosstalk

EQUIPMENT PERFORMANCE MEASUREMENTS TABULATION OF DATA

Station _____
Date _____

Frequency, Hz.									
50									
100									
400									
1k									
5k									
7½k									
10k									
12½k									
15k									

Main to Subchannel Crosstalk
in dB (No Specification)
95% L+R Modulation

Incidental Phase Modulation
Same as above, expressed
in Radians. No Specification
95% L+R Modulation

Subchannel to Main Crosstalk
No Specification
95% L-R Modulation

Station _____
Date _____

MAILED SUBJECT AREA CIRCULAR
(ALSO)
INCIDENTAL PHASE MODULATION
L + R, 95% MODULATION

L + R to L - R
Crosstalk

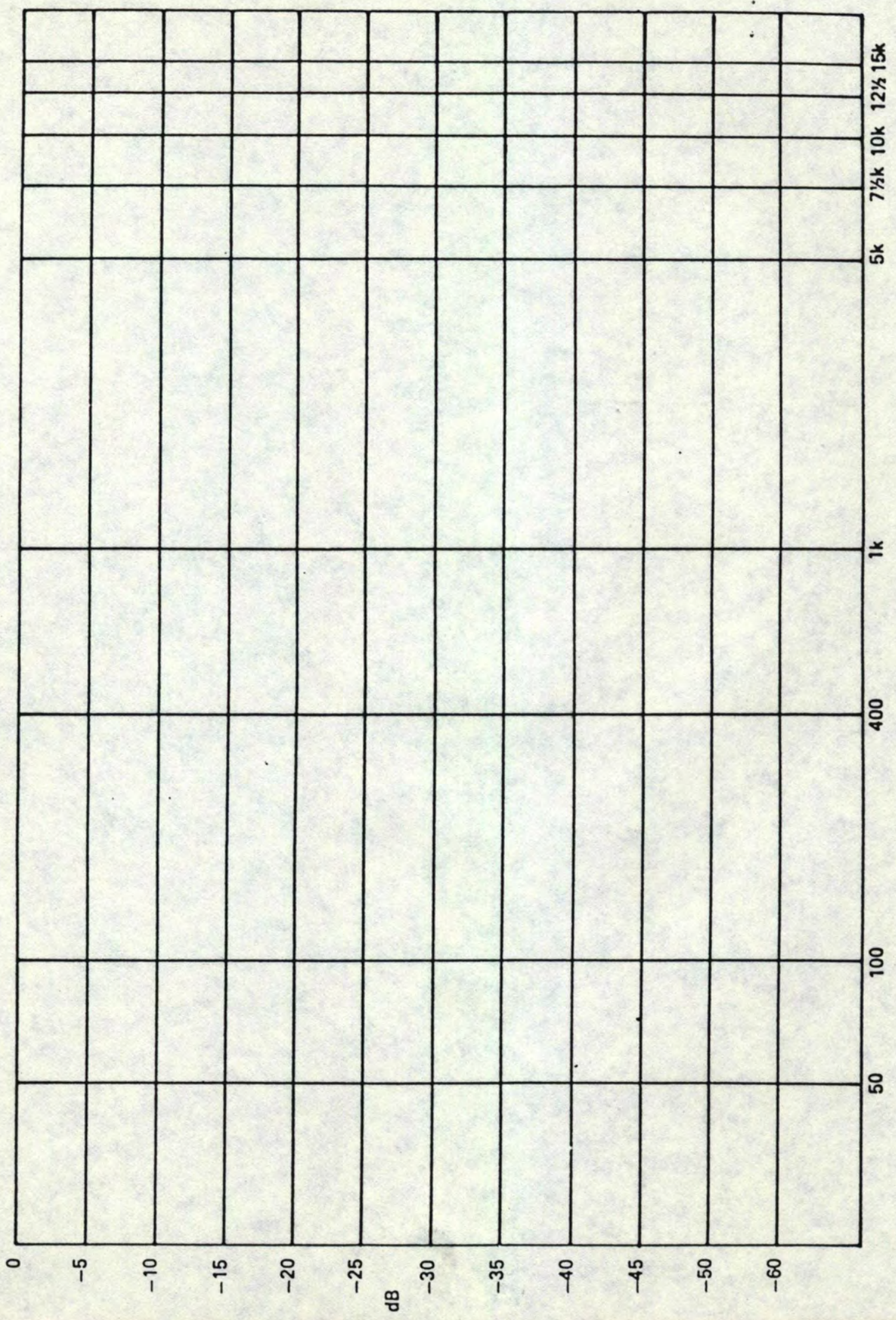

L - R Crosstalk

SUBCHANNEL TO MAIN CROSSTALK

L - R, 95% MODULATION

Station _____
Date _____

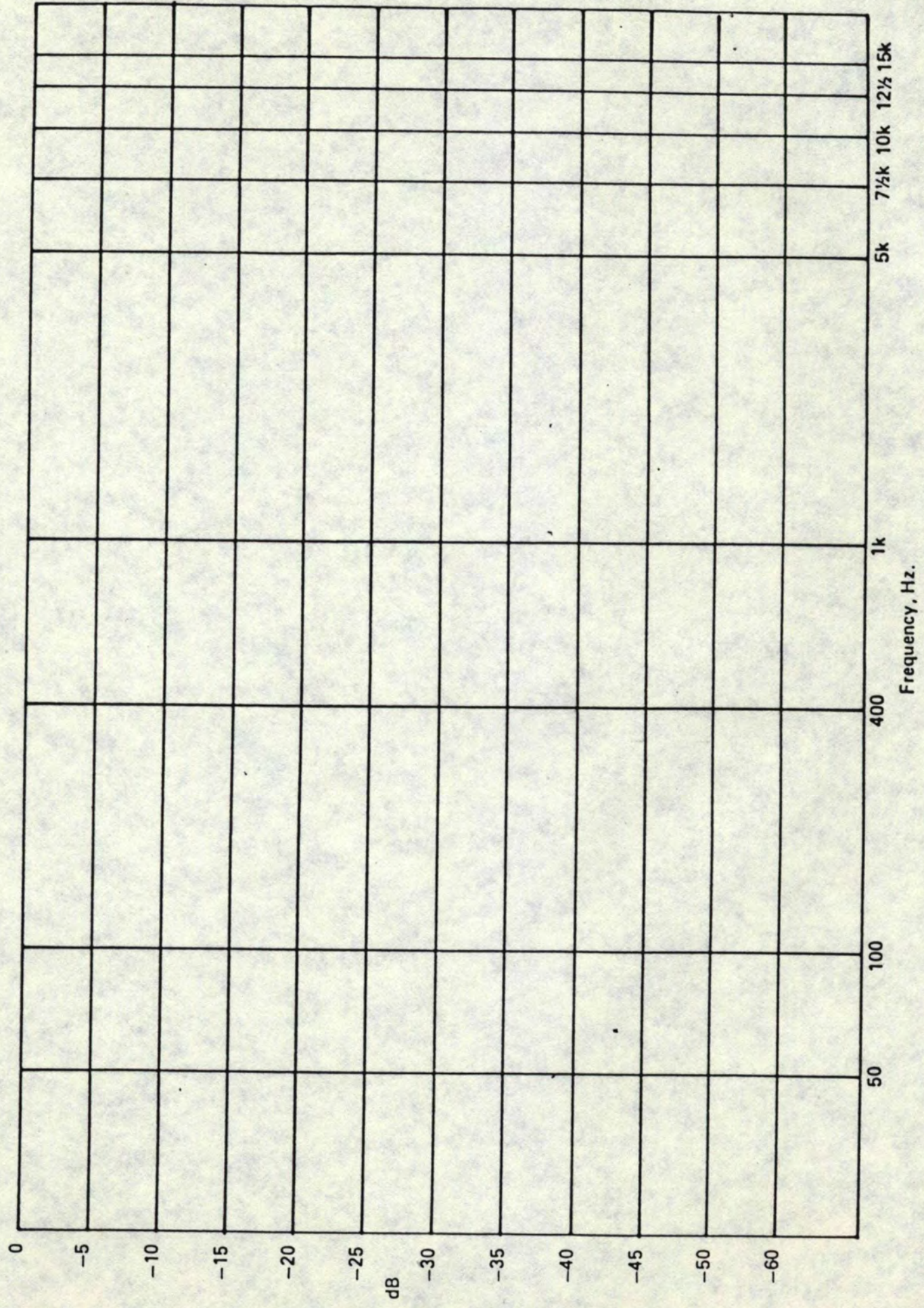

EQUIPMENT PERFORMANCE MEASUREMENTS
TABULATION OF DATA

Station _____

Date _____

Carrier Shift

L + R, 100% Modulation _____ %

L + R, 85% Modulation _____ %

L + R, 50% Modulation _____ %

L + R, 25% Modulation _____ %

Noise Level
Below 100% at 400 Hz.

L + R _____ dB

Left _____ dB

Right _____ dB

Harmonic and Spurious Observations,
L + R, L - R, Left, & Right _____
