

**TDS SERIES
TWIN DECK REPRODUCER**



**AUDI-CORD
CORPORATION**

1845 W. Hovey Ave., Normal, Illinois 61761

Phone (309) 452-9461

Design Innovators - Quality Manufacturers

If You Didn't Get This From My Site,
Then It Was Stolen From...

www.SteamPoweredRadio.Com

Table of Contents

TWIN DECK "TDS" SERIES REPRODUCERS

	PAGE
1.0 GENERAL DESCRIPTION	1
1.1 Un-Packing	1
1.2 Models and Accessories	2
2.0 SPECIFICATIONS	3
3.0 OPERATION	6
3.1 Getting the Most From the Cartridge System	6
3.2 Selecting and Using the Customer Operating Options	7
3.3 Constructing Output Pads	9
3.4 Controls and Indicators	10
3.5 Audio Connections	11
3.6 Remote Control Connections	12
3.7 Operator Periodic Maintenance	12
4.0 CIRCUIT DESCRIPTIONS	14
4.1 Power Supply and Power Switching Circuits Card	14
4.2 Twin Deck Logic Circuits Card	14
4.3 Program Amplifier(s) and Cue Circuits Card	16
4.4 Output Circuits Card	18
5.0 TRANSPORT DESCRIPTIONS	19
5.1 The Tape Drive Systems	19
5.2 Head Mountings and Tape Guides	19
5.3 Cartridge Sensors	19
5.4 Cartridge Guides and Hold Downs	20
6.0 TRANSPORT DIAGNOSIS AND MAINTENANCE	21
6.1 Transport Failure or Cartridge and Tape Failure?	21
6.2 Adjustment of Cross-Shaft Mechanism	22
6.3 Solenoid Adjustment	23
6.4 Motor Adjustment, Top Deck	23
6.5 Lower Deck Stop Adjustment	23
6.6 Tape Guide and Head Height Adjustment	24
6.7 Head Penetration, Angle and Cartridge Tape Wrap	25
7.0 ELECTRICAL MAINTENANCE	26
7.1 Adjustment of Lower Deck Azimuth and Phase	26
7.2 Head Azimuth and Phase, Routine	26
7.3 Frequency Response and Equalization	28
7.4 Program Output Level(s)	28
7.5 Cue Detectors Gain	29

8.0	TROUBLESHOOTING	30
8.1	Mechanical Failures in the Tape Drive System	30
8.2	Logic and Control Circuits	31
8.3	Program Amplifier and Cue Circuits	32
8.4	Parts Identification and Ordering Parts	32
8.5	Symptoms and Possible Cause Chart	33
9.0	CIRCUIT CARD SCHEMATICS AND PICTORIALS	
10.0	INTERCONNECTIONS (MOTHER BOARD) SCHEMATIC	
11.0	WARRANTY	

AUDI-CORD CORPORATION

"TDS" SERIES TWIN DECK REPRODUCERS

1.0 GENERAL DESCRIPTION

The Audi-Cord Corporation TDS Series Twin Deck Reproducers represent a practical design in multi-deck tape cartridge reproducers that are cost-value engineered for long and reliable service. We hope you will be pleased in your selection of these machines and the service they will provide. Please take a few minutes to read and understand this instruction book before placing the unit in service. To do so will undoubtedly provide you with important information from which to realize the most from your investment.

The TDS Series contains the latest in solid state components and modern hardware, designed into a readily accessible unit with a minimum of discreet wiring. The only moving parts are the solenoid and the associated tape engaging mechanism. The operator controls are on the front panel along with the important annunciator lights arranged for ease of operation and understanding.

The TDS Series is designed in harmony with the 1976 NAB Cartridge Standards and it's intent; however certain level and response parameters are supplied to be more consistent with the needs of the U.S. domestic market use. These parameters are readily altered by the user to the 1976 NAB Standard when desired, following the instructions in Section 7.0, Electrical Maintenance and Section 3.3, Constructing Output Pads.

1.1 Un-Packing

Please un-pack carefully and retain the shipping materials until a full inspection is completed.

Before plugging the "TDS" Series into the proper power source examine the equipment for shipping damage both exterior and interior. Audi-Cord Corporation makes every possible attempt to design the equipment and the packing such that they will arrive in safe condition; however, rough handling by the carrier can not always be avoided.

Examine each circuit card to insure it has not worked loose from its socket and inspect heavy members such as the transformers to insure they have not been broken loose or shifted on their mountings.

If damage has occurred, please notify Audi-Cord first for advise on claims so that we may avoid un-necessary delay to the repair and your use of the equipment.

1.2 MODELS AND ACCESSORIES

The TDS Series Twin Deck Reproducer is available in two standard models.

MODEL TDS-1 - Monophonic with 3 NAB Cue Tones
MODEL TDS-6 - Stereophonic with 3 NAB Cue Tones

other models are available only on special quantity orders and factory quotation.

An accessory rack mounting shelf, part no. 502-0046 is available for mounting up to two (2) units side by side in a rack conforming to RMA standards.

2.0 SPECIFICATIONS: "TDS" SERIES REPRODUCERS

Rated Audio Output	+8dBm max., factory pad installed for 0 dBm output
Amplifier Overload Capability	+18 dBm min., +20 dBm clipping Loss Pad Out
Minimum Input Level	+8 dBm min. from 160 nWb/m fluxivity, Pad Out
Rated Output Impedance	600 ohms or 150 ohms Balanced Selectable
Amplifier Output Impedance	*300 ohms on 600 ohms tap *90 ohms on 150 ohms tap
Amplifier Distortion	0.5% max total harmonic @ +18 dBm
Hum and Noise	-52 dB re 160 nWb/m @ 1Khz, Mono -48 dB re 160 nWb/m @ 1kHz, Stereo
Signal to Noise (<i>Typical Tape</i>)	-47 dB re 160 nWb/m @ 1kHz
Crosstalk, Cue to Program	50 dB or better @ 1 kHz
Crosstalk, Program To Program	50 dB or better @ 1 kHz
Start Time	0.12 Sec. Max. @ Min. Solenoid Damping
Stop Time	0.08 Sec. Max. @ Min. Solenoid Damping
Equalization	*Per NAB Cartridge Standard, 1964, Adjustable, due to customer demand
Equalization Adjustment	Both high and low frequencies Adjustable
Frequency Response	+2 dB to NAB Standard Tape specifications, typically limited by head contour effects @ low Frequencies

Does not fully meet the 1976 NAB Standards

Phase Stability	<u>+90</u> degrees, Long Term @ 12 kHz <i>Transport is long-term phase stable for selected cartridge under controlled measurements. It is appreciated that phase differential over a group of cartridges and long term use is difficult to achieve unless stringent maintenance and operator techniques are applied. This specification, therefore, represents a best case intent and cannot be guaranteed in the user's application under present typical operations.</i>
Cue Tones	1kHz Primary, 150 Hz Secondary Cue and 8 kHz Tertiary, Standard
Cue Inhibit Time	1.75 sec <u>±</u> .25 sec. Electronic Timed
SEC/TER Cue Switching	Sinking (open collector) logic
Cue Switching Loads	100 ma. max., +40 VDC open circuit max.
Logging Output Isolation	40 dB min., from 10K ohm source
Cue Sensor Bandwidth	<u>+5%</u> min @ 6 dB points
Cue Sensor Gain	10 dB minimum Reserve @ NAB Std. Level
Tape Speed	7.5 IPS, Hysteresis Synchronous Direct Drive
Timing Accuracy	.2%, 250 Sec. Tape Method
Effective Speed Accuracy	.2% NAB Method
Flutter	0.15% weighted peak, Maximum

Remote Control (*all inputs
are ground signalled*)

15 Pins, permanently wired for:

Start
Stop
Run Lamp
Ready Lamp
Secondary Cut Out
Tertiary Cue Out
Gnd (*Chassis*)
+24 DC
Logging Cue Output

Cartridge Capability

NAB AA and BB sizes

Max. Temp. Rise

20 C. Max. above 25 C ambient

Recommended Max. Ambient

40 C max.

Power Requirements

117 volts, 60 Hz, 60 VA max.
(117 volts, 50 Hz, on special order)

Dimensions

8½"W x 7½"H x 13¼"L

Weight

26 lbs.

3.0 OPERATION

3.1 GETTING THE MOST FROM THE CARTRIDGE SYSTEM

It is Audi-Cord's desire that every owner of the "TDS" Series Reproducer obtain long and satisfactory service from the equipment; however, since the "TDS" Series is manufactured to accommodate a wide variety of cartridges from several manufacturers', it is often true that optimum performance is the result of the users knowledge of the differences in these cartridges and their best applications. If these factors are well known, the mechanical fit of the machine and the cartridge can often be optimized by the skilled technician for best performance. Characteristics which most often influence performance of a given cartridge in any machine are as follows:

1. The mechanical fit of the cartridge to the heads and the keyhole opening.
2. The pressure pad design adequacy and fit to the heads as well as interference to the tape guides. In erase/record applications for instance only a few types will adequately wrap these off center head designs.
3. The friction loss of the cartridge and tape and its' pulling tension. Unlimited tension cannot be handled by the transport since the capstan and roller surface engagement area is limited in the inherent design. Tension typically increases significantly with longer time loads and in wear life.
4. Contamination of the head surfaces if poor tape and lubricant is encountered.
5. The internal quality control and maintenance routines.

The above characteristics are all important if failure of the system is to be avoided. It is unfortunately true that all cartridges are not the same in design and, it is virtually impossible to produce a cartridge transport that performs perfectly with all the types; therefore, the user must select the cartridge and tape best suited to his needs and then make such minor adjustments to the transport as necessary to obtain optimum performance.

Our Service Department will provide assistance when needed and excellent general information is to be found in our Users' manual and the occasional updates that have been issued.

3.2 SELECTING AND USING THE CUSTOMER OPERATING OPTIONS

The "TDS" Series reproducers are equipped with a Replay Reminder and Lockout System for each deck and an automatic Motor Shut Down feature when both decks have played. The customer selects how he uses these features to suit the needs of his own operation.

REPLAY REMINDER and LOCKOUT SYSTEMS- This feature is valuable in line operations to prevent double airing of carts that have been previously played. The feature is selected by switch S1, located on the top of the Twin Play Control Logic Card 151-68.

Select this feature to turn on the "Played" lamp and remove the "Ready" status and it's lamp by setting Sections A and B of switch S1 to the "on" position for the lower deck and sections C and D of switch S1 to the "On" position for the upper deck.

If it is desired to turn on the "Played" lamp only and not remove the "Ready" state, turn on section A of switch S1 for the lower deck and section C for the upper deck, leaving sections B and D in the "off" position.

The TDS reproducer is factory wired to allow reset of the Replay Reminder by either removing the appropriate cartridge or by pushing the "Stop" pushbutton of the associated deck. If it is desired to exclude the "reset" by STOP pushbutton feature, clip the buss link at the top of the card for either or both decks. This link is located on the R.H. side (parts facing) for the top deck and on the L.H. side for the bottom deck.

MOTOR SHUTDOWN FEATURE- This feature is electrically designed to follow the use of the "READY" status of either deck with the Replay Lock-out. If both decks have been played and therefore may be idle for some period, the motor is turned off to conserve energy and heat in the machine.

If either deck cartridge is replaced or "Stop" reset is performed, the motor is turned back on. Of course, the motor requires approximately 2 seconds to arrive at full speed and must be a consideration by the operator.

X If it is desired that the motor run continuously, replace diode D7 on the logic card with a link of wire.

Circuit Card 151-68

TWIN PLAY LOGIC

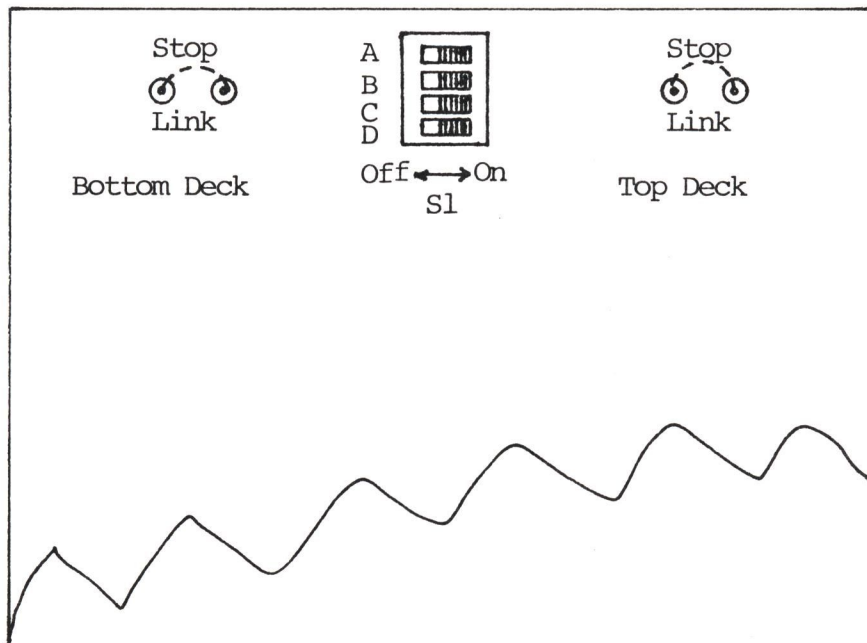

3.3 CONSTRUCTING OUTPUT PADS

The "TDS" Series Reproducer is designed for +18dBm maximum audio output before amplifier clipping occurs and can be used to deliver up to +8dBm in 600 ohms as required by the 1976 NAB Cartridge Standards; however, most domestic U.S. audio consoles have at best limited inputs suitable for this level without installation of loss pads which are most usually constructed at the source, such as the cartridge machine.

To avoid delay in connecting the "TDS" Series to most consoles and systems, Audi-Cord has elected to ship these machines with internal pads constructed for the more common 0dBm output level requirement. The following table and drawing will show the design of the internal loss pad located in each channel of the Output Circuits Card 151-70. This card is easily removed by removing the four (8) tapped screws of the output sockets and un-plugging the card from the mother board. Refer to the following table and the card pictorial drawing in Section 9 for location and values of the loss pad components for various needs.

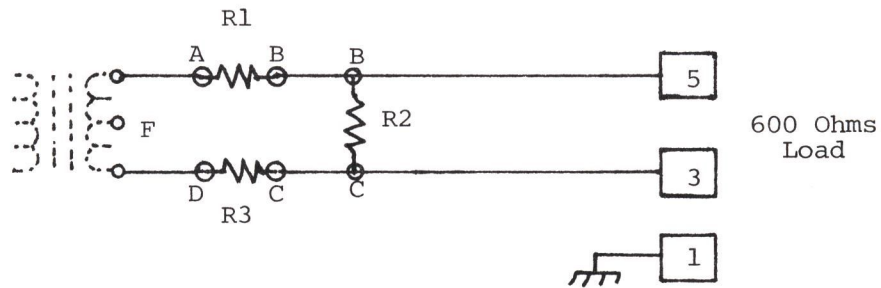

<u>VALUE R1 AND R3</u>	<u>VALUE R2</u>	<u>LOSS dB</u>	<u>600 ohms OUTPUT RATING</u>
0 ohms (wire)	Inf. (open)	0	+8 dBm
120 ohms	390 ohms	4	+4 dBm
180 ohms	470 ohms *	8*	0 dBm *
240 ohms	120 ohms	14	-6 dBm
270 ohms	60 ohms	20	-12dBm
270 ohms	22 ohms	28	-20dBm

* Factory Installed

3.4 CONTROLS AND INDICATORS

The operator controls and indicators for the TDS Series reproducers consist of two sets, conveniently grouped for operator identification of the deck with which they are associated. Each group contains an arrow symbol pointing to the deck which they operate with. The function of each control or indicator without reference to the deck used are as follows:

POWER LIGHT	Indicates that the machine is on and that the +24 DC power is present.
READY LIGHT	Indicates that a cartridge has been properly installed and is ready to play. (this lamp is part of the STOP pushbutton.)
STOP PUSHBUTTON	Stops the transport and/or resets the REPLAY reminder when this option is selected. (Remember that manual stop of a cartridge leaves it in an un-cued state and, the cart should be advanced to cue before removal.)
RUN LIGHT	Indicates that the transport is in the run mode and playing.
START PUSHBUTTON	Places the transport in the run mode.
PLAYED LITE	Indicates that the cartridge in place has received the Primary Cue Tone and has been played.
TER LITE	Indicates when the TER cue tone is being received.
SEC LITE	Indicates when the SEC cue tone is being received.

CARTRIDGE SENSOR

Signals the logic when the cartridge is installed and causes other circuit functions to operate.
(Internal switch located between the heads.)

FRONT PANEL CONTROLS

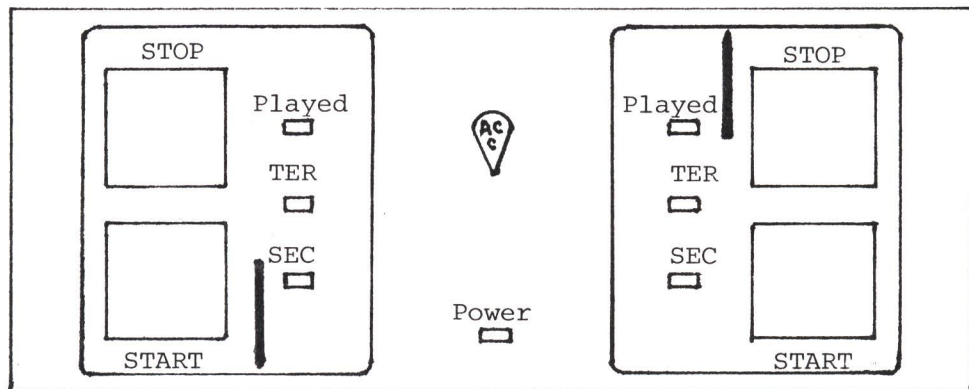

3.5 AUDIO CONNECTIONS

The program output is connected to J11 for the top deck and J21 for the bottom deck. These are located on the rear panel. Use the mating plug supplied. Two wire shielded cable is recommended for this connection. If the required length is more than a few feet, the shunt capacitance effect should be considered to avoid possible high frequency line losses. When connecting shields, it is usually desirable to connect to chassis ground on one end only to avoid possible hum loops between the cartridge equipment and the connected console or amplifier.

The Connecting diagram is as follows:

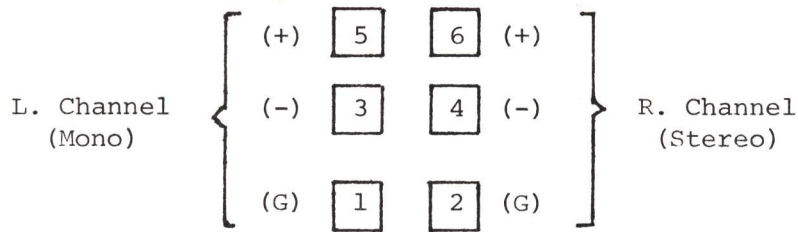

3.6 REMOTE CONTROL CONNECTIONS

The 12 pin remote control connectors J12 for the top deck and J22 for the bottom deck are factory connected for the 10 normally required outputs. The typical remote control connections are as indicated in the pin diagram below.

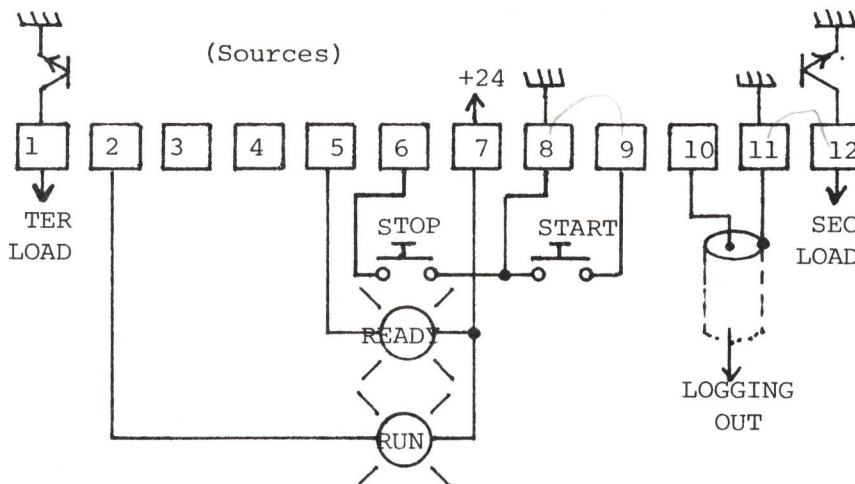

3.7 OPERATOR PERIODIC MAINTENANCE

The operator is often charged with, or may find it necessary to perform periodic cleaning maintenance and other inspection to insure proper operation of tape cartridge machines. These maintenance routines may be daily or weekly depending upon the amount of use.

These typical maintenance functions are as follows:

CLEAN HEADS, PRESSURE ROLLER and CAPSTAN SURFACES-

These cleaning functions are very important if good air quality is to be achieved. Dirt on heads can cause high frequency losses in replay or recording due to tape spacing from the head gaps and, under worst cases cause total loss of audio or the cue functions.

Lubricant build up on the pressure roller surface or the capstan surface seriously degrades pulling capability due to loss of contact friction on these driving surfaces and under worst cases will cause serious "wow" or slip of the tape.

Clean these surfaces with denatured alcohol or isopropol alcohol solvents, readily available at most hardware stores, by saturating and wringing dry a soft cloth or swab to avoid dripping of solvent into the motor bearing, etc. Do not use solvents such as Xyolene or Kerosene since these seriously degrade rubber parts.

INSPECT CARTRIDGE and TAPE FOR PROPER OPERATION-These inspections, especially before re-recording can save the failure later on. Do not attempt to record tape which is slick on either the oxide or the lubricant (rear) surface. Slick oxide surface usually means that much of the oxide is missing and proper recorded levels cannot be achieved without serious distortion and loss of high frequency material. The cue tones especially will usually be weak and may not function properly.

Loss of lubricant means that pulling tension has seriously increased and will soon cause "slip" in the playing sound. It is almost certain that short life will be experienced before breakage of the tape occurs.

Proper operation of cartridges are normally detected during daily use. The careful operator may observe potential recurring failures and avoid their occurrence. Periodic audio drop-out for instance may relate to a badly deformed pressure pad or increasing tension which may overcome the pressure pad conformity.

Erroneous cues can indicate "pops" on the cue channel which cause false tripping or stop of the drive system. Failures of these types should result in setting aside the cartridge for further off air testing to determine if they should be used or, if machine maintenance is required.

4.0 CIRCUIT DESCRIPTIONS

4.1 POWER SUPPLY AND SWITCHING CIRCUITS CARD

The D.C. power supplies, solenoid switching circuits and the motor switching circuit are located on the plug-in circuit card 151-69. Refer to the schematic in Section 9.

Diodes D1 and D2 provide rectified DC from the center tapped winding of the power transformer to capacitor C1 for smoothing. This approximately 33 volts DC is fed to edge connection pin 18 and, to the input of the 24 volt regulator U1 for further filtering and use in the machine control circuits. It is also fed thru diodes D3 and D4 and resistors R1 and R2 to the solenoid switching circuits explained later.

Diodes D6 and D7 in a similar manner supply approximately 18 volts DC to the input of the 12 volt regulator U2. This regulated and filtered 12 volts DC is used for the audio and logic control circuits.

Transistor Q1 is a power switch for the solenoid of the upper deck. Capacitor C5 is charged to the 33 volts DC supply when the machine is idle and serves as a "boost" voltage source to accelerate the solenoid when Q1 is first turned on by the logic driver. Diodes D13 and D15 serve as transient suppressors for the solenoid inductance and diode D14 acts as an isolation diode for the Run Lamps.

The circuits for the lower deck is identical and are provided by transistor Q2 and the associated parts.

Integrated circuit U3 (light activated SCR) along with diodes D9 thru D12 serve as an isolated AC switch to turn the capstan motor on or off from the logic signal "MOTOR=0".

Diodes D5 and D8 protect their respective voltage regulators from accidental reverse voltage failure.

4.2 TWIN DECK LOGIC CIRCUITS CARD

The logic to control playing functions of both decks are located on the plug in circuit card 151-68. Refer to the schematic in Section 9.

The schematic is formatted such that most input signals are shown on the left side with output decision signals exiting on the right side. Internal word statements define some of the major signal paths for assistance in understanding. The logic 1 state is at or near +12DC volts and logic 0 state is at or near chassis ground potential.

Two identical sections of logic are contained on this card for the most common functions, while one output, Motor=0 is derived in OR format. This purpose will be described later. Integrated circuits U1, U2 and U3 are exclusive to Deck #1 (the upper deck), while U6, U7 and U8 are their counterparts exclusive to Deck #2. One half of U5 and U9 as well as sections of U4 are common to both decks. The following description will be of Deck #1 circuits only and is the same functionally except for part numbers in the case of Deck 2 circuits.

Integrated circuit U2 is a two section SET-RESET latch. Section 2 is the START-STOP latch, while section 1 is the Replay Reminder latch. Section 3 of U1 is the steering section for the START signal. When Ready=0 and Start=0 are present, pin 10 is at logic 1, setting the RUN latch to ON. Pin 13 of U1 produces a RUN=! logic for use in the cue and program control circuits, while pin 12 thru section 4 of U1 and transistor Q1 produces the RUN DRIVE signal used in the solenoid switching circuit.

U3 integrates the three signals STOP (P.B.), CUE=1 and CART SW (in=1) for decision of the rest of the circuits. When the CART SW. is at logic 1 and INHIBIT=1 (not inhibited), either CUE=1 or STOP P.B.=0 causes U3 pin 6 to produce a stop=1 signal to reset U2. When CUE=1, pin 9 of U3 causes the REPLAY REMINDER latch, pin 6 to turn on, creating the PLAYED=1 signal and turning on the PLAYED light via transistor Q2. In the lower deck (#2) the PLAYED light is via section 1 of U10.

The PLAYED=1 signal is coupled via switch 1 section D to pin 1 of U1. This signal produces an output logic 1 at pin 3, removing the READY=0 signal. In a similar manner, if a cartridge is not in place (CART SW=0), pin 8 of U4 turns off the READY=0 via pin 2 of U1.

The REPLAY REMINDER latch, U2 pin 4 is reset each time the cartridge is removed or, if the link between pin 5 and pins 11 and 12 of U3 is in place, this reset occurs by the STOP pushbutton.

Pin 10 of Section 2, U5 sees the RUN=1 signal each time the machine is started. This action triggers the output at pin 12 of U5 to INHIBIT=0. The duration of this inhibit is determined by C9 and R21 and is factory set at approximately 1.75 seconds.

Integrated circuit U9 pin 1 and pin 2 are connected to the logic of each deck. These signals are identified as MOTOR 1=1 and MOTOR 2=1. If either deck remains in the READY state the output of U9 pin 3 is at MOTOR=0, turning the motor on. If both READY states are missing such as the cartridges out or both decks are PLAYED, the motor is turned off to conserve power and heat. If it is required that the motor run continuously, replace diode D7 with a link of wire.

4.3 PROGRAM AMPLIFIER(S) and CUE CIRCUITS CARD

The program and cue circuits are both contained on a single circuit card 151-67. There are two identical cards, one for each associated deck. The card located on the extreme L. side is for the top deck (Deck #1) while the second card from the L. side is for the lower deck (Deck #2). Refer to the schematic in Section 9.

PROGRAM AMPLIFIER(S) SECTION- The play head(s) are connected via cables and 3 pin connectors on the rear of the card nearest the deck plate. Stereo models have 2 connectors in this location. The top connector is L. channel and the bottom is R. channel. Observe the identification dots on the cable when plugging in these cables to avoid interchange of the channels.

I.C. U1 is a low noise packaged pre-amplifier with approximately 40dB of mid range gain. Two frequency equalizers are provided in the gain loops. For L. Channel of stereo or mono models, R8 is the adjustable low frequency equalizer of limited range in the inverting feedback section. C5 sets the crossover frequency for

R8, which is adjusted typically at 50Hz to improve the low frequency loss and contour effect of the head used. The base gain is established by R5 and C4 while the equalized portion is set by R7. Capacitor C6 bypasses the mid to high frequencies.

R2 is the adjustable portion of the high frequency shunt equalizer, while C2 and R3 establishes the crossover frequency of the equalizer. Resistor R4 establishes the DC feedback bias in conjunction with R6. Level control R9 allows for output level adjustment.

I.C. U2 is a 4 section FET analog control switch to control turn off of the audio during non-running periods. Resistor R36, R37 and R38 and Capacitor C16 provide a ramp-up and ramp-down time to avoid audio pops.

Transistor Q1 is a split phase pre-driver for the complimentary output amplifier Q2 and Q3. The output is coupled thru C19 to the primary of the line transformer located on the Output Circuit card.

The R. Channel of stereo models is identical to the description of the L. Channel above except for the change in part number designations.

CUE AMPLIFIER AND DETECTORS

The cue head is connected via a 3 pin connecting cable located on the rear of the circuit card.

Intergrated circuit U3 is configured in a two stage equalized pre-amplifier with output essentially constant for the 3 NAB cue tone flux levels. This output is connected thru R49 and C28 to section 2 of I.C. U4 which acts as the isolation amplifier for logging signal outputs, used frequently in automation and accessory controllers. This output is routed to pin 10 of the remote sockets and is often valuable for cue track monitoring and test functions.

Section 1 of I.C. U4 is configured as a bridged T passive amplifier tuned to the 1 kHz center frequency. This circuit is stable and will require no further tuning. The output is connected via C33 to transistor Q7. This is a zero bias A.C. detector coupled thru R61 to C34. These components along with R60 form a time constant to delay turn on of Q8 for approximately 20 milli-seconds to immunize the circuit from short transients and remove "clatter". Q8 derives the logic signal CUE=1 for automatic stop control.

Section 1 of I.C. U5 is similarly the 150 Hz Secondary Cue passive amplifier while section 2 is typically used as the 8kHz Tertiary signal. In some cases, this circuit is tuned to other frequencies as customer option.

I.C. U6 is used as the control gate for the SEC and TER outputs and to derive an End of Secondary Cue pulse for use with special customer needs.

I.C.'s U7 and U8 are output load drivers, 1/2 of each used for the internal signal lights while the other 1/2 is routed to the remote control socket for customer use.

4.4 OUTPUT CIRCUITS

The Output Circuit Card 151-70 is located at the rear of the playback and is removed by loosening the 8 output jack mounting screws and un-plugging from the mother board.

This card contains the output audio pads and the foil wiring for the output circuits, both audio and remote control.

A typical drawing of the output pads and values to change the output level is in Section 3.3. Refer to the card pictorial drawing for locations of the components.

5.0 TRANSPORT DESCRIPTION

5.1 THE TAPE DRIVE SYSTEM

The tape drive system in the TDS Series Reproducers consists of the air damped solenoid, a tensilized mylar drive band, a unique pressure regulating driving roller and the cross-shaft.

The cross-shaft is suspended within the stress relieved deck casting on two adjustable ball bearing end pivots which allow rotating freedom without undesired end lash. The regulating drive roller is eccentric in design to provide extra mechanical advantage without increasing solenoid throw. Internal to this roller is a neoprene rubber insert of similar hardness to the pressure roller material except, it contains approximately one third the pressure surface area. This design affords a three to one pressure storage as a series element for the solenoid. Since all DC solenoids change in pull with internal heat effects, these shifts in pull cause changing pressure and indent of the pressure roller. This will result in tape drift on the capstan if not contained in some manner. The system used in the TDS Series deck, combined with the inherent clearance of the pressure roller bearing, affords an excellent correction for normal service and wear factors.

5.2 HEAD MOUNTINGS AND TAPE GUIDES

The head mountings are of inverted design, allowing for top adjustment of the heads and easy removal from the deck when desired. The entire assembly is mounted with two screws and is re-located exactly by locating pins and mating holes in the deck surface.

The mountings of the bottom deck are modified to provide a R. Side access to the play head azimuth adjustment. This is a two screw adjustment which by necessity is used as a minor correction method during routine touch up adjustment. If heads are to be replaced requiring height and zenith adjustment, it is best to temporarily mount this assembly on the upper deck for access and first azimuth procedure. The mount is then placed on the lower deck and the final azimuth/phase adjustment performed. The tape guides are of two piece design to allow for exact adjustment to the tape width and are reversible for wear when required.

5.3 CARTRIDGE SENSOR

The cartridge sensor consists of a moving plunger located directly in the cartridge center and a grounding contact at the rear of the mechanism. This system is ultra simple and durable, requiring only occasional cleaning to insure that the contact operates properly.

5.4 CARTRIDGE GUIDES AND HOLD DOWNS

Two types of cartridge guides are used in the "TDS" Series Reproducers. The monophonic models are simple angle devices supplied for both left and right sides to allow easier cartridge insertion in these less critical applications. The stereo models use over top combination cartridge guides and spring hold downs to better level and position the cartridge for stereo accuracy. In all cases, the cartridge center hold down spring is used to assist in stabilizing the center area of the cartridge and close any gaps due to warp that may be present in the plastic shells.

6.0 TRANSPORT DIAGNOSIS AND MAINTENANCE

6.1 TRANSPORT FAILURE OR CARTRIDGE AND TAPE FAILURE

The user of tape cartridge machines is often confronted with tape and drive failures such as "wow" or slip in operation which can seriously degrade air sound. It is often assumed that something is wrong with the machines pull (torque), and the engineer is asked to make an adjustment to "fix" the problem. Unfortunately it is not possible to "fix" a transport drive to pull tape under unlimited demand and is often erroneous and damaging to adjust the motor and solenoid spacing in such attempts. The tape cartridge system is limited by several inherent factors historic to the endless loop cartridge design. These are the keyhole and the size of the pressure roller and capstan which it will accomodate. It must be recognized that with the small shaft and roller surface area, the lubricant necessary to the tapes very operation, etc. that the pull under clean and new condition of all members is limited and is constantly being changed by condition of the roller and shaft. Under nominal conditions, tests indicate that the tape slip crosses the 0.2% speed specification when pull required to move the tape is approximately 4.5 ounces for typical tape. For this reason, the 1976 NAB Cartridge Recording Standards sets a 3 ounce maximum pulling tension for the tape and cartridge design and maximum load used. Most cartridges supplied will meet this requirement when new, however; tests indicate that many increase in tension to exceed this requirement in just a moderate amount of use and exceed the 4.5 ounce typical useful drive tension in 200 use trips or so.

If slip from higher than useful pulling tensions occur for an extended period of time, serious wear of the pressure roller and capstan running surfaces will occur, degrading these parts performance to the point that re-newal will become necessary to restore original capability. The pressure roller can be easily replaced however restoring the hardened rough surface of the capstan shaft is typically a factory maintainance or expensive replacement cost.

For the reasons presented above, the user must give serious consideration to the diagnosis of fault in the operation of cartridge machines in his studio operations. Many factors contribute and many can be avoided. Some of the factors of which the user should become aware of are as follows:

- (A) Long tape loads should be avoided except where absolutely necessary. The longer the tape load, the higher the risk of exceeding pull limitations.
- (B) Be aware that cartridge designs that add extra friction surfaces such as extra posts, etc. typically pull harder than simple loop cartridges and may result in less wear trip life.
- (C) Periodically inspect cartridge and tape condition. Look for slick oxide surface, cupping or wrinkling along tape edges or worn out lubricant. These are signs of extra tightening of the tape supply hub and should be discarded or carefully tested before further use.

If transport maintenance is required, it is usually due to necessary removal of the motor or solenoid or loose cross-shaft bearings which allow too much side to side motion of the cross-shaft, relieving bottom roller contact on the capstan. If wear has caused a change of pressure roller diameter, it is more desirable to replace the roller than to attempt the critical position of the motor adjustment which is vertically related to the new diameter of the roller and is important to the horizontal drive attitude of the tape in motion, and critical if good tape guidance is to be realized in stereo application.

6.2 ADJUSTMENT OF THE CROSS-SHAFT MECHANISM

The cross-shaft is adjusted for "0" end lash consistent with free rotation. The center of the pressure roller shaft and the center of the capstan shaft are offset such that the pressure roller is .010" to the right (facing), or nearer the tape return side of the cartridge. This insures a slight tape wrap and maximum tape contact to the capstan.

Access to the end bearing retaining screws is gained by removing the stainless overlay plate. Remove the two cartridge side guides, the head mounting frame and the solenoid drive band to loosen the plate.

It is best to take up the bearing slack by adjusting the outer (R.H.) end bearing only, leaving the L.H. bearing in place to maintain the roller centering on the capstan.

6.3 SOLENOID ADJUSTMENT

This adjustment is made by releasing the top clamp screw in the end of the solenoid plunger, allowing the band to move in the clamps. Pull the solenoid in electrically and push gently on the end of the plunger to feel the bottom position. Proper adjustment sets the plunger as close to bottoming without pull-in "click" as possible. (approx. .015" from bottom). The pressure regulator within the drive roller compensates for the solenoid pull properly when this plunger setting is close to correct.

6.4 MOTOR ADJUSTMENT, TOP DECK

IMPORTANT: If any removal or adjustment is made to the motor position, the lower deck stop adjustment, Section 6.5 below must be made also or serious guidance errors may occur in the lower deck. The motor is located such that the parallel spacing between motor shaft and pressure roller shaft faces are 0.285"-0.290". Use a precision parallel gauge block or other suitable spacer for measurement. If such a tool is not available, carefully place the lower edge of the pressure roller to just touch the capstan shaft. You should then see approximately .005" light (space) between the top edge of the roller and the capstan. Run tape briefly on the cleaned surface of the roller and observe that the tape imprint is thru the center of the roller. This is a field emergency method that will result in fairly accurate results.

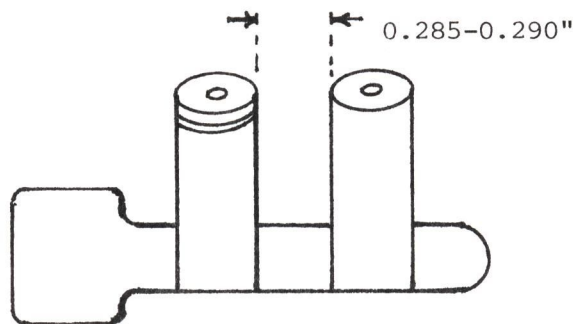

6.5 LOWER DECK STOP ADJUSTMENT

This adjustment is made and locked at the factory. If the motor position has not been altered by repair necessity or disassembly has resulted, no further adjustment should be necessary. If adjustment becomes necessary, this is accomplished by adjustment of the stops behind the lower panel jack screws which locate the depth of the deck penetration with regard to the lower motor shaft.

Remove the lower cabinet from the machine and place the machine on it's left side for access. If a gauge is available with a center hole of 0.187" diameter and an

Outer diameter of 0.775" remove the deck temporarily and replace the pressure roller with this gauge and replace the deck against its' stops.

Remove the pressure roller stop plate located under the deck. Loosen the lock nuts on the panel stops. Proceed with either of the following adjustment techniques.

If the gauge is used, rotate the gauge surface against the capstan and observe for parallel. If not parallel, make the appropriate adjustment in or out on the panel stops equally on both sides. Observe gap between the panel and the frame along each side. Place panel back against the stops and rotate the gauge against the capstan again, observe parallel. Continue such adjustments until a perfectly parallel gauge mate exists. Lock the stops with their lock-nuts.

If no gauge is available, leave the pressure roller in place and follow the field emergency method in the Top Deck adjustment, Section 6.4 above in lieu of the gauge.

6.6 TAPE GUIDE AND HEAD HEIGHT ADJUSTMENT

If heads are changed or serious adjustment of the lower deck head mountings are considered necessary, it is advisable to temporarily exchange the lower head assembly for the top deck assembly to make such adjustments including initial azimuth electrically.

The lower guiding surface of the upper guides is located 0.562 inches above a precision flat surface. The upper guiding surface of the lower guides is set typically 0.248 inches lower. This may be done by precision measurement to the surface plate or by using a penetrating gauge such as a Johannsen block.

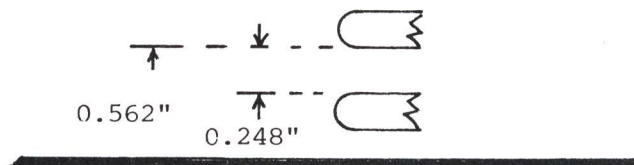

Adjust the head center line to 0.438" (7/16) above the deck surface. Typically the upper and lower extremes of the pole pieces will be at the edge of the tape. A piece of clear leader strung carefully through the tape guides will serve as a practical means of adjustment.

The head zenith is carefully aligned for vertical perpendicularity of the head face to the deck surface. A small square or machined block may be used. Do not touch the face of the head with metallic objects as scratches and magnetism may be instilled in the head, especially with steel objects.

6.7 HEAD PENETRATION, ANGLE AND CARTRIDGE TAPE WRAP

The proper head penetration is $0.285 \pm .010$. A convenient means of measurement is to scratch a line on the front edge of a typical clear cartridge cover.

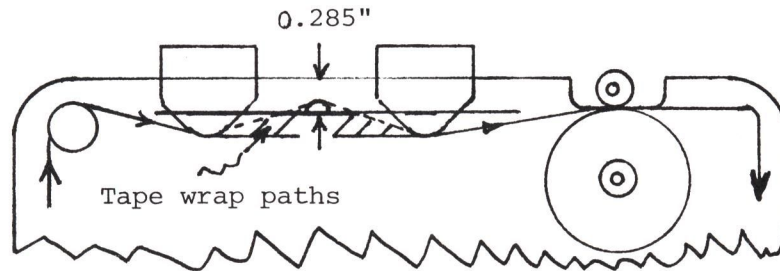

The head angle has been traditionally designed to face straight to the front in cartridge machines with pressure pads and a center post in place to create the center of the heads wrap. This center wrap has always been less than the outer wrap however some of the modern cartridge designs have removed the center guide and its assistance in tape wrap in lieu of the added skew often caused by this center member. With these cartridges and those which the pressure pad is small, it is often necessary to angle the head physically in the mount to better provide head gap contact with the tape and avoid otherwise worse result in tape "drop-out" due to loss of conformity to the head surface under changing tensions of the tape.

It is unfortunately impossible for Audi-Cord Corporation to provide machines "fine tuned" to the users' cartridge and of course the design allows a minimum of change of angle adjustment of the head front surface therefore the user is faced with determining if the head angle should be and can be changed to improve tape "drop outs" with the type of cartridge he uses and, if he should use one specific type of cartridge. The process is at best one of experimentation with results. Audi-Cord will offer service consultation and our best advise in such cases to assist the user in getting the best performance possible from the equipment.

7.0 ELECTRICAL MAINTENANCE

7.1 ADJUSTMENT OF LOWER DECK AZIMUTH AND PHASE

The TDS Series reproducer lower deck uses a head mounting assembly modified to provide better convenience of minor azimuth/phase adjustment from two side screws which can be adjusted while the deck is in operation with the standard tape in place. The top screw (see sketch in this Section) is a wedge-lock screw while the bottom screw is the "tilt" screw. By nature these screws work with each other and both should be loosened slightly then tightened one at a time observing result as in Section 7.2 below. Each screw should end up moderately tight to insure that the adjustment is locked in position however, over tightening is not necessary.

If heads are replaced or coarse adjustments of head height is felt necessary, it is easiest to interchange temporarily the lower deck mount to the upper deck for extensive adjustment and better vision.

7.2 HEAD AZIMUTH AND PHASE, ROUTINE

HEAD AZIMUTH-MONOPHONIC

Verify that the head height, penetration, and zenith are as recommended in the Transport Maintenance Section before attempting the following adjustments:

1. Connect a 600 ohm resistor to the audio output connector. Connect a VTVM across this load.
2. Play a known standard 15 kHz azimuth tape.
3. Adjust the play head azimuth for maximum output as read on the VTVM.
4. Tighten the head lock screw, observing that the output reading remains at maximum.

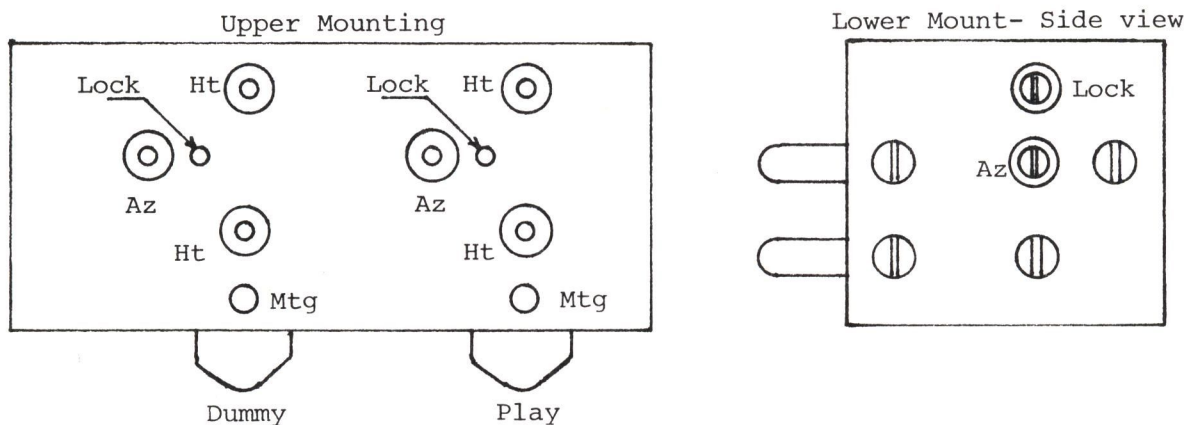

PHASE ADJUSTMENT-STEREOPHONIC

1. Connect 600 ohm loads to both L and R output of the audio connector.
2. Connect a VTVM across the Left Channel load. Adjust the play head azimuth for maximum output reading from a 15 kHz full track azimuth tape.
3. Connect the vertical input of an oscilloscope across this channel. Connect the horizontal input (or channel 2 of a two trace scope triggered from channel 1 zero crossing) to the Right Channel output. Adjust the play head azimuth for in-phase display of the two channels. Refer to Figure 1 below for typical phase displays.
(Phase jitter is normal during these tests.)

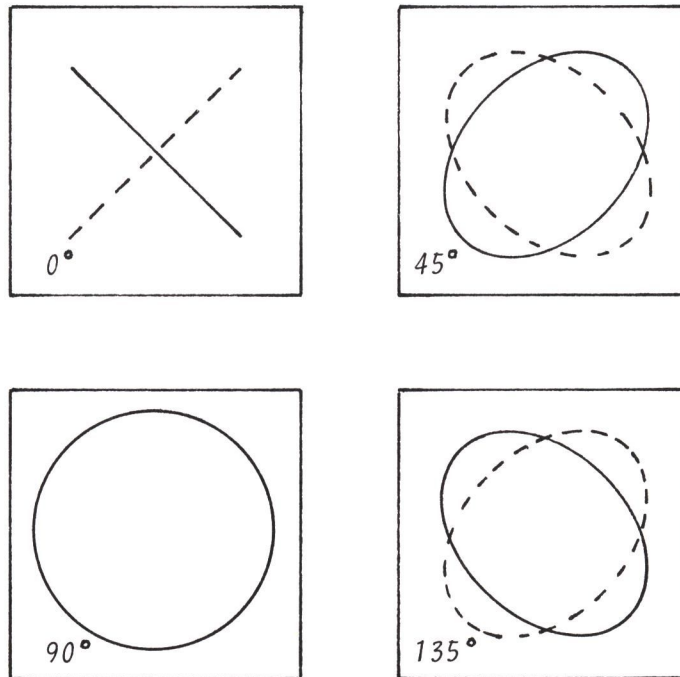

Fig. 1

4. Play a full track tape with frequencies from about 1 kHz through 15 kHz in several non-harmonically related frequencies. Observe that the phase display remains in phase for all frequencies.
5. Tighten the head lock screw, observing that phase shift does not occur.

7.3 FREQUENCY RESPONSE AND EQUALIZATION ADJUSTMENT

1. Install a known accurate frequency response tape such as the NAB Standard Tape or one prepared on a calibrated Audi-Cord record/play machine.
2. Play the tape and observe the results for frequencies above 1 kHz. Adjust the Hi frequency equalization control R2 (*and the companion R11 for Right Channel of stereo units*) for flattest response of frequencies from 1 kHz through 15 kHz.
3. Observe frequencies from 1 kHz down to 50 Hz. Write down each output level and apply fringing corrections if a full track tape is used.
4. Adjust the Lo frequency equalization control R8 (*and the companion R17 for Right Channel of stereo units*) for flattest response from 50 Hz through 1 kHz.

7.4 PROGRAM OUTPUT LEVEL

1. Play a standard level tape of the operating flux level choice. Adjust the program Play Level Control R9 (*and the companion R18 for Right Channel of Stereo units*) for the desired output. Do not exceed +0 dBm.

NOTE: Audi-Cord playbacks are factory adjusted for 0 dBm from a reference fluxivity of 160 nWb/m at 1 kHz in accordance with the 1976 NAB Cartridge Standards. A loss pad of 8 dB design is factory installed.

7.5 CUE DETECTORS GAIN

1. Record a tape with each tone at 6 dB below normal recorded level. Refer to "Cue Tone Level" of the recorder instructions for method of adjusting a recorder oscillator.
2. Play this tape and adjust R52 for reliable operation of each sensor.

NOTE: Audi-Cord playback sensors utilize a specially equalized preamplifier and closely designed switching electronics. There should be only a very minor difference in the single cue gain setting for any tone at proper recorded level. A single control in combination with wide rejection latitude of the sensor will tolerated considerable difference in recorded level as required.

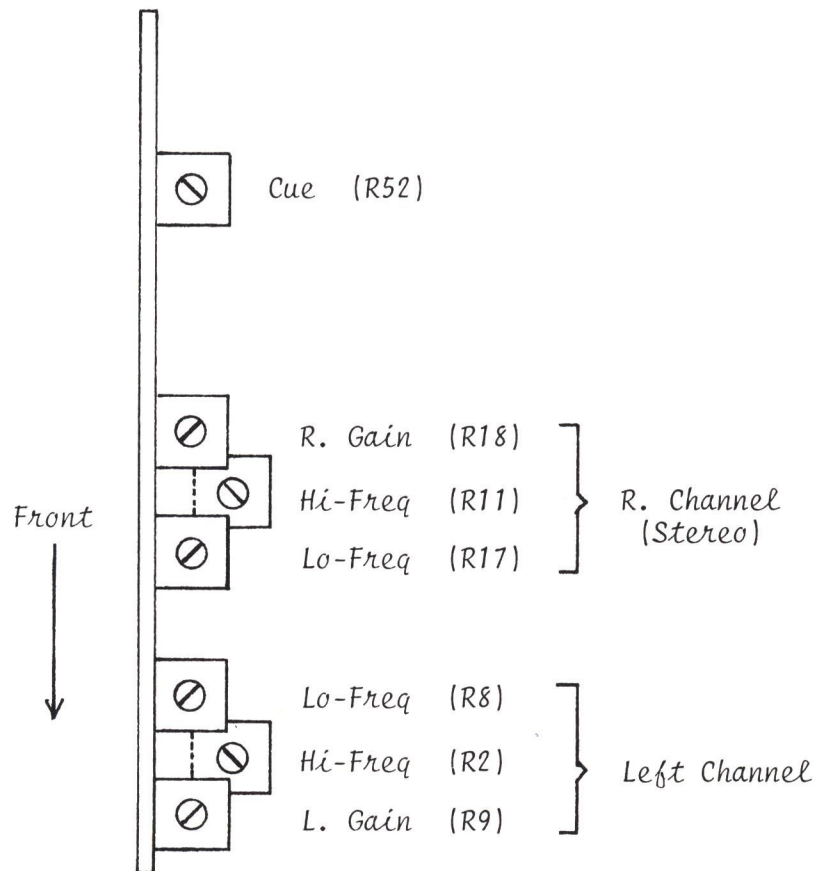

8.0 TROUBLESHOOTING

The maintenance of this equipment precludes that the technician is acquainted to a high degree with solid state logic and the troubleshooting techniques required for proper diagnosis of these circuits.

Many of the voltages to be measured in the TDS Series are current limited by high series resistances or impedances. Typical 20,000 ohms per volt multi-meters though useful, may frequently burden the voltage measurement in such a manner as to leave the indications inaccurate. For instance, a voltage measurement on the 50 volt range (*1 meg ohm internal meter impedance*) with a 470K ohm pull-up resistor to 12 volts would result in a reading of approximately 8 volts instead of 12 volts as a logic HI indication. No serious difficulty would likely result in such a measurement, only confusion of the operator. For this reason, it is desirable to use high impedance measuring instruments for troubleshooting when these are available.

8.1 MECHANICAL FAILURES IN THE DRIVE SYSTEM

The TDS Series transport and other mechanical members are designed with a minimum of moving parts and maximum of simplicity. The description of the transport in Section 5.0 contains information valuable in understanding the mechanism and some clues to the operation. The Transport Maintenance (Section 6.0) describes several adjustments when removal and replacement is necessary. Other failures that occur are often related to the mechanical compatibility with specific cartridges and the operating peculiarities. Some of these are:

RECORDING DROP-OUT- These failures are most often due to improper contact of the tape to the head during tape motion. Some of the causes are improper pressure pad, small pads which are not on center with the head gap, cartridge not held into full head penetration position due to lack of keyhole pull-in spring, lack of wrap between the heads because the center post has been removed on some carts and tape that sheds excessive dirt on the head surface. (Refer also to Section 6.1)

To make judgements on these performances, remove the cartridge hold down spring and carefully observe the tape running path. If it does not touch and maintain on the output side of the record head, it may be necessary to pivot the head for better tape contact. If the cartridge is pushed away from the forward position due to lack of keyhole spring to hold it forward, it will be necessary to add sufficient cartridge hold down spring pressure to hold the cart in place against the heads.

It is often difficult to adjust heads and springs to accommodate a variety of carts in usage. For this reason, it is often desirable to standardize on a minimum of types, or a single type for general use.

TAPE PULLING DIFFICULTIES- These failures are probably the most mis-understood and frequent complaints. They have always existed in cartridge systems due to tension increases during life operation, and more recently aggravated by added tension posts, etc. within the cartridge designs along with the wider spread use of long loads in music and mixed commercial programming. The mechanical failures usually relate to worn pressure rollers, polished motor shafts, high pressure pad friction and interference with the keyhole preventing the pressure roller shaft from having rotating freedom, effectively preventing pressure transfer to the capstan and roller surfaces. Physical examination will usually reveal the solution to these difficulties. (Refer also to Section 6.1)

8.2 LOGIC AND CONTROL CIRCUITS

The schematics and pin terminal signal statements for the TDS Series will frequently be in logic terms. The statement will be in the "true" logic state as written. For instance, the term "*Cart. In=1*" relates that if the cartridge is properly in place, the voltage will be at logic 1 (*HI*), or 12 volts in the case of CMOS logic such as used in this equipment. If the cartridge is not in place, the reverse statement is true. In this case the voltage will be logic 0 (*LO*) or near 0 volts.

Refer to the schematics in Section 9.0 for signal lines in and out. Also observe carefully the signal lights for their function. This will offer

valuable clues as to the logic portion which has failed. Since some signals can be influenced by their interconnecting circuits thru feedback, unplug the rear connectors for test purposes and re-plug one at a time if their failure is indicated. Most failure components encountered are plug-in and may easily be replaced from spares for the final correction.

8.3 PROGRAM AMPLIFIER AND CUE CIRCUITS

These circuits are combined on a common circuit card, one for each deck. If failure is apparent, temporarily exchange these cards to verify the failure of on card components. These components are likely to be plug-in and may be further interchanged for verification. An interconnecting cable extension can be easily prepared using standard parts for out of machine testing. Monitor of the cue signals and any information on the cue track is easily accomplished on Pin 10 of the Remote Connectors at the rear of the reproducer. False signals which often cause erroneous cue failures can also be monitored on this output.

8.4 PARTS IDENTIFICATION AND ORDERING PARTS

Electronic parts and purchased hardware parts used in the "TDS" Series are identified on the schematic section applicable in most cases. These part numbers are common Distributor Network parts numbers and are not proprietary Audi-Cord numbers; therefore, they are readily available from local sources in many cases as well as from Audi-Cord stock. For these reasons, we do not compile parts lists for inclusion into this book.

Audi-Cord can supply any part required. Simply refer to the Model Number, Serial Number, symbol number and card assembly or other common term description and address parts orders to our Service Department, who will properly supply the parts required. We also offer recommended spare parts lists and kits of these parts at nominal costs to assist the owner in his maintenance spare stock needs.

8.5 SYMPTOMS AND POSSIBLE CAUSE CHART

SYMPTOM INDICATION POSSIBLE CAUSE ACTION

No Power Apparent	No "Power" Lite	Fuse Blown, Switch "OFF" Line Cord not Connected	Check Visually or with Ohmmer
	Fuse OK, Power "ON"	R.F. Choke RFC1 or RFC2 Open	Check for Open, Place Ohmmer across line terminals, Turn on Power Switch. Should read Transf. Primary
No DC-Above Tests OK	No "Power" Lite +12 or +24 Dead	Transformer Sec. Open-Power Supply 151-59	Check Transf. with Ohmmer
	No "Ready" Lite	Logic Card,	Replace card
Motor does Not Run	"Ready" Lite on	Cartridge Sensor Shorted	Replace or Test
		Logic Card,	Temporarily Remove Wire to Sensor. If "Ready" and Motor operates, repair Sensor.
	Power Supply Card, U3	Replace or Test	
Solenoid Does Not Operate	No Motion	Solenoid Open-"Run" Lite is Operating	Jumper Across Pin 4 and 5. See if Motor runs.
	No "Run" Lite	Q1 Open on Logic	Check with Ohmmer
		Q1 Open on Power Supply	Substitute in Parallel
		U1, on Card 151-67	Check with ohmmer (Approx. 40 ohms)
No Play Audio One or More Tracks	No Output at U1, Q1, Q2 or Q3 on 151-67 (L. Chan.)	Open Head or Cable	Replace or Test
	"Run" Lite Stays On	Shorted Q1-Logic, Q1-PWR Sup.	Check for Continuity (500 ohms)
	All Channels	Head Dirty	Replace
	Sounds Slow	Cartridge Too Tight	Clean with Alcohol
	Loud Roar	Pressure Roller Dirty	Replace
Won't Stop High Freq. Loss Tape Slips		Open filter Capac. on P.S.	Clean with Alcohol
		Grounded Head	Replace
Hum in Audio		Broken Deck Ground Wire	Repair
		U3, U4 on 151-67	Replace
Will Not Cue	Doesn't Stop on Cue	Open Head or Lead	Use Ohmmer for Continuity
	No Sig's @ J12 Pin 10	Cue Gain Turned Down	Reset to Level
	Sig's @ J12, Pin 10	U4, Q7 or Q8 on 151-67	Replace or Test
	Cue=1 Sig is OK	U3, U2, U5 on Logic	Replace
Played Doesn't Latch	Re-Starts After Cue	Check S1 Positions	See "Operating"
	Stops OK	U2, U3, U4 on Logic	Replace

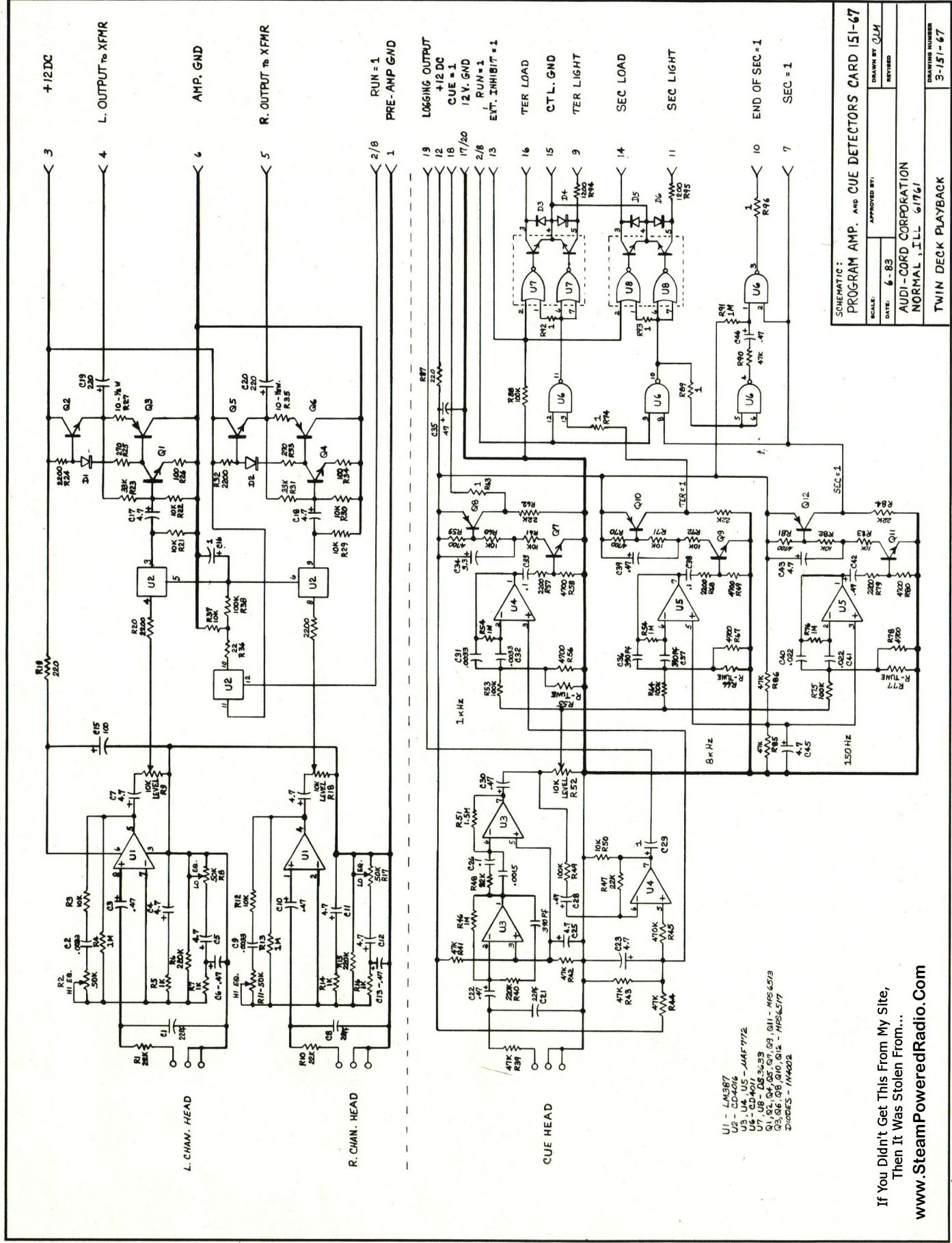

If You Didn't Get This From My Site,
 Then It Was Stolen From...
www.SteamPoweredRadio.Com

SCHEMATIC: PROGRAM AMP. AND CUE DETECTORS CARD 151-67
 DRAWN BY: CLM
 REVISION:
 DATE: 6-83
 APPROVED BY:
 AUDI-CORD CORPORATION
 NORMAL, ILL. 61761
 DRAWING NUMBER
 3-151-67

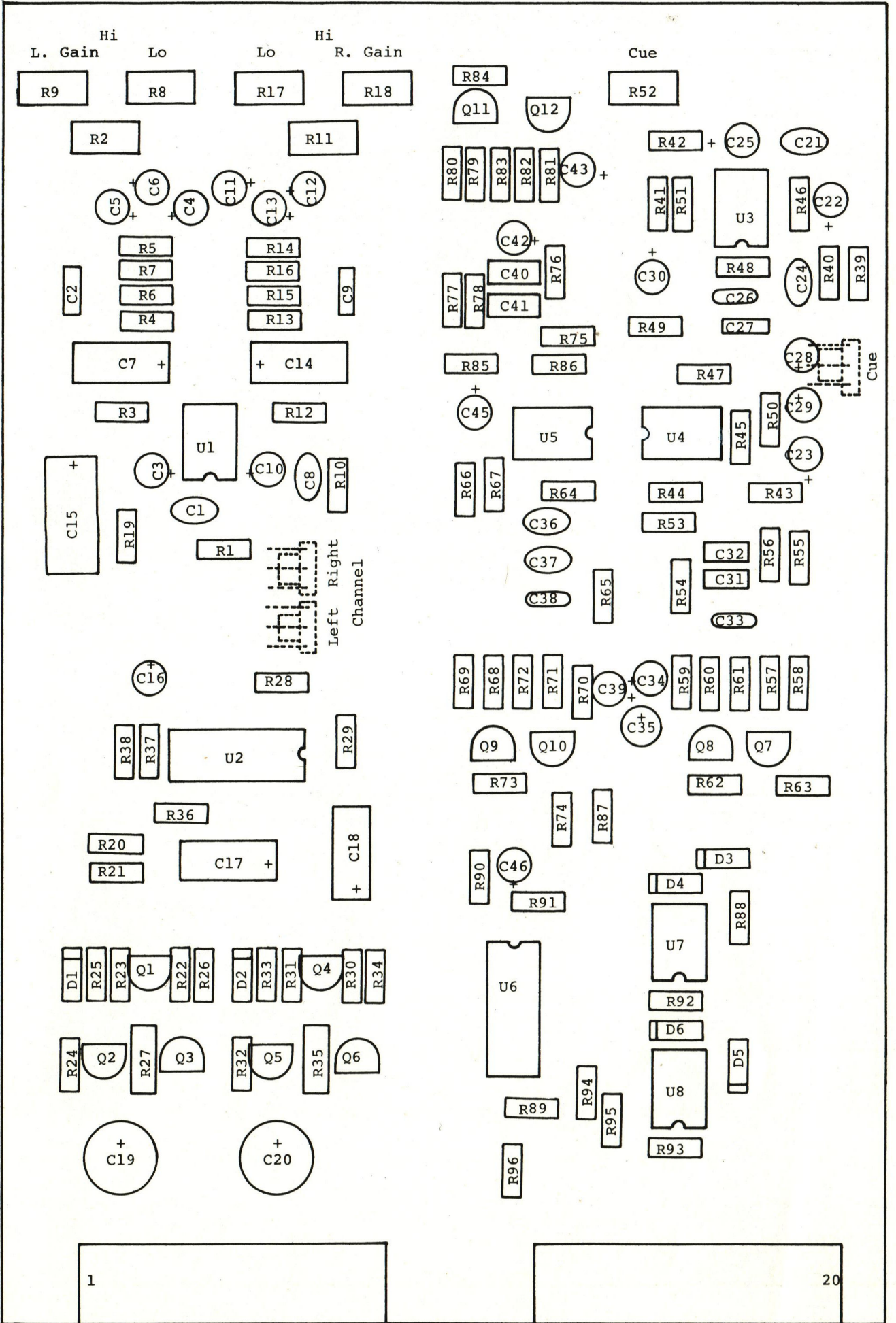

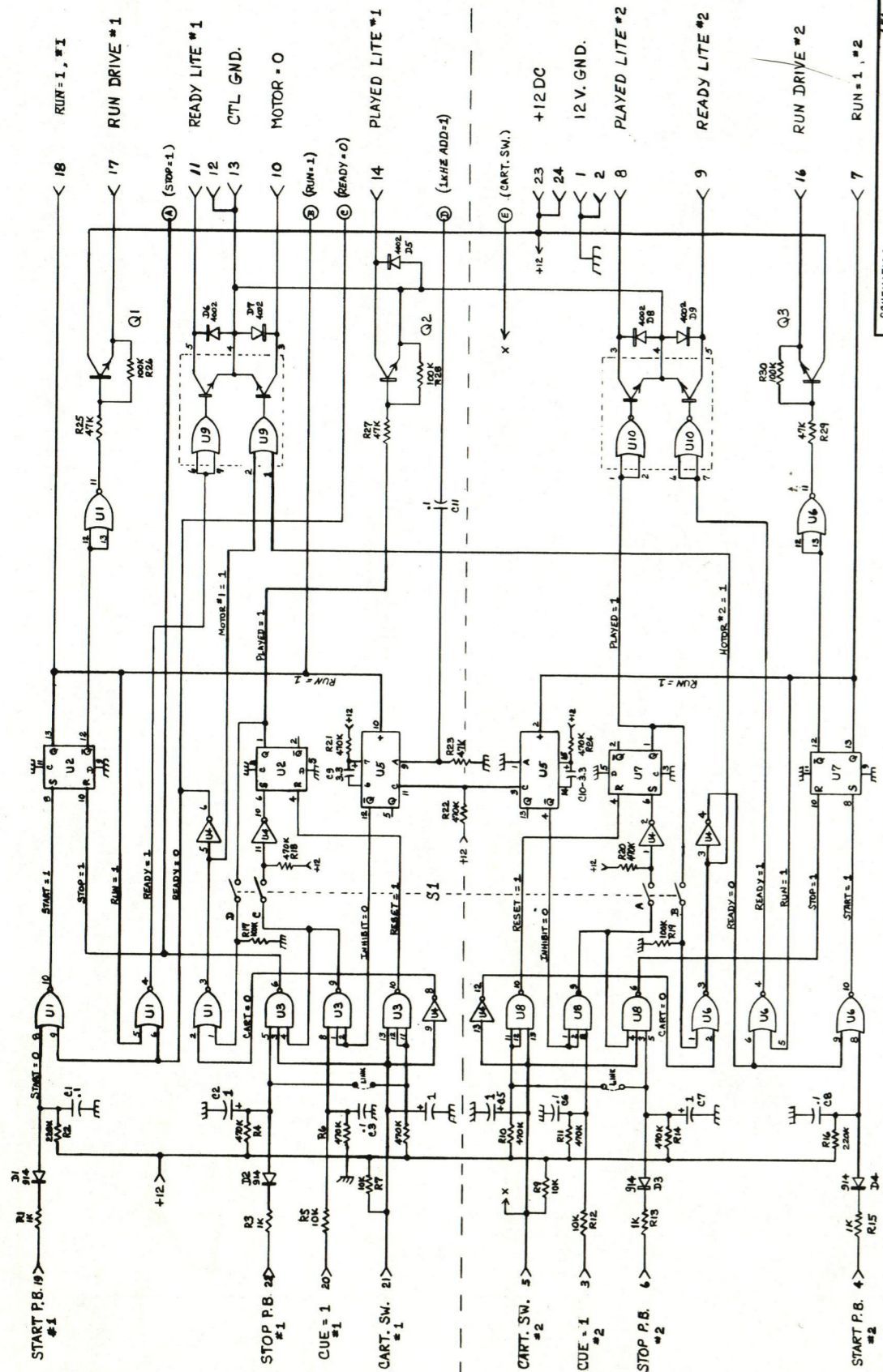

151-68
TWIN PLAY CONTROL LOGIC CARD
 SCALE: APPROVED BY:
 DATE: 5-83 DRAWN BY: GJM
 REVISED:
 AUDI-CORD CORPORATION
 NORMAL, ILL. 61761
 TDS SERIES
 DRAWING NUMBER
 3-157-68

If You Didn't Get This From My Site,
 Then It Was Stolen From...
www.SteamPoweredRadio.Com

U1, U6 = CD4001
 U2, U7 = CD4013
 U3, U8 = CD4025
 U4 = CD4049
 U5 = 74C21
 U9, U10 = DS3634
 Q1, Q2, Q3 = 2N5307

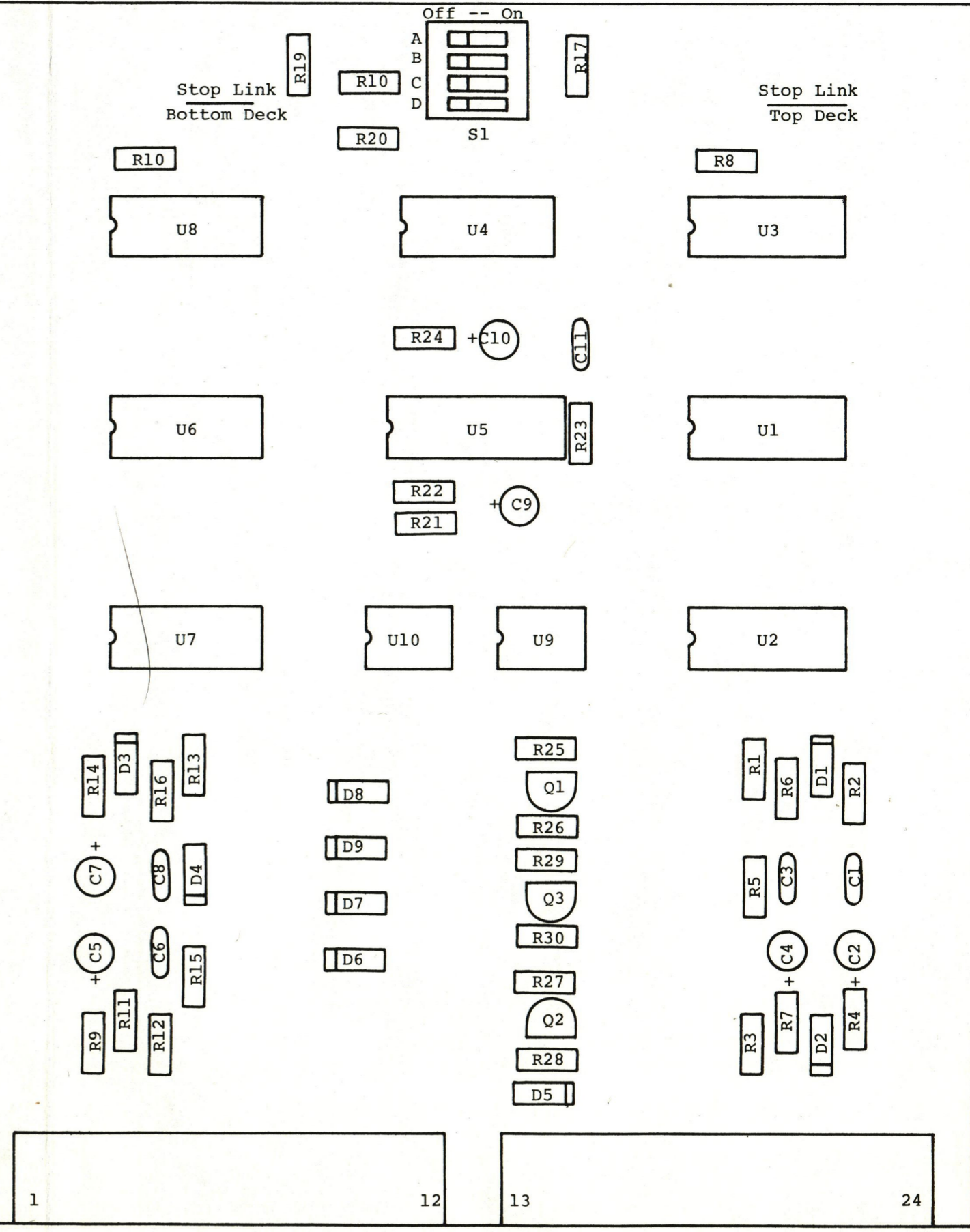

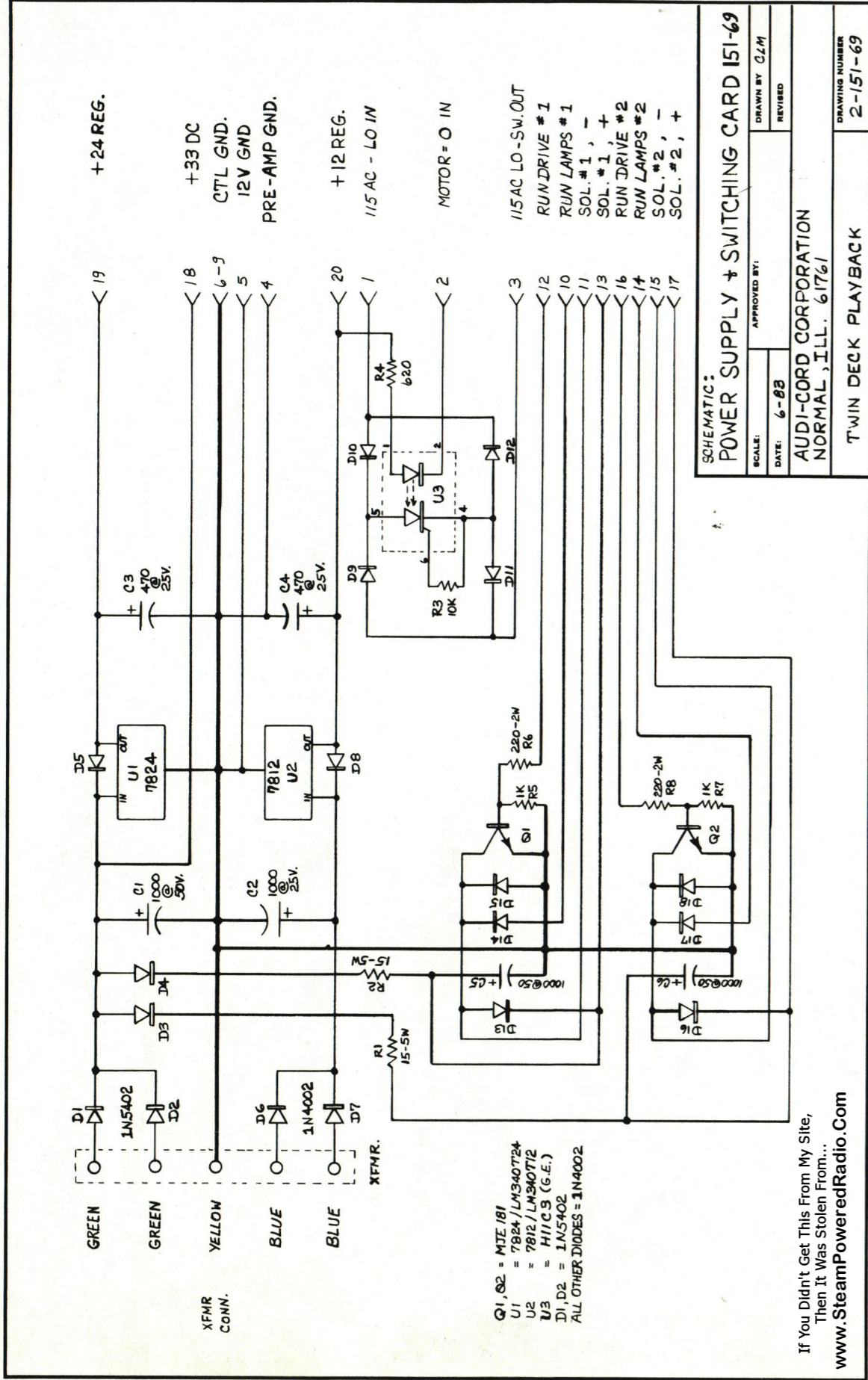

If You Didn't Get This From My Site,
 Then It Was Stolen From...
www.SteamPoweredRadio.Com

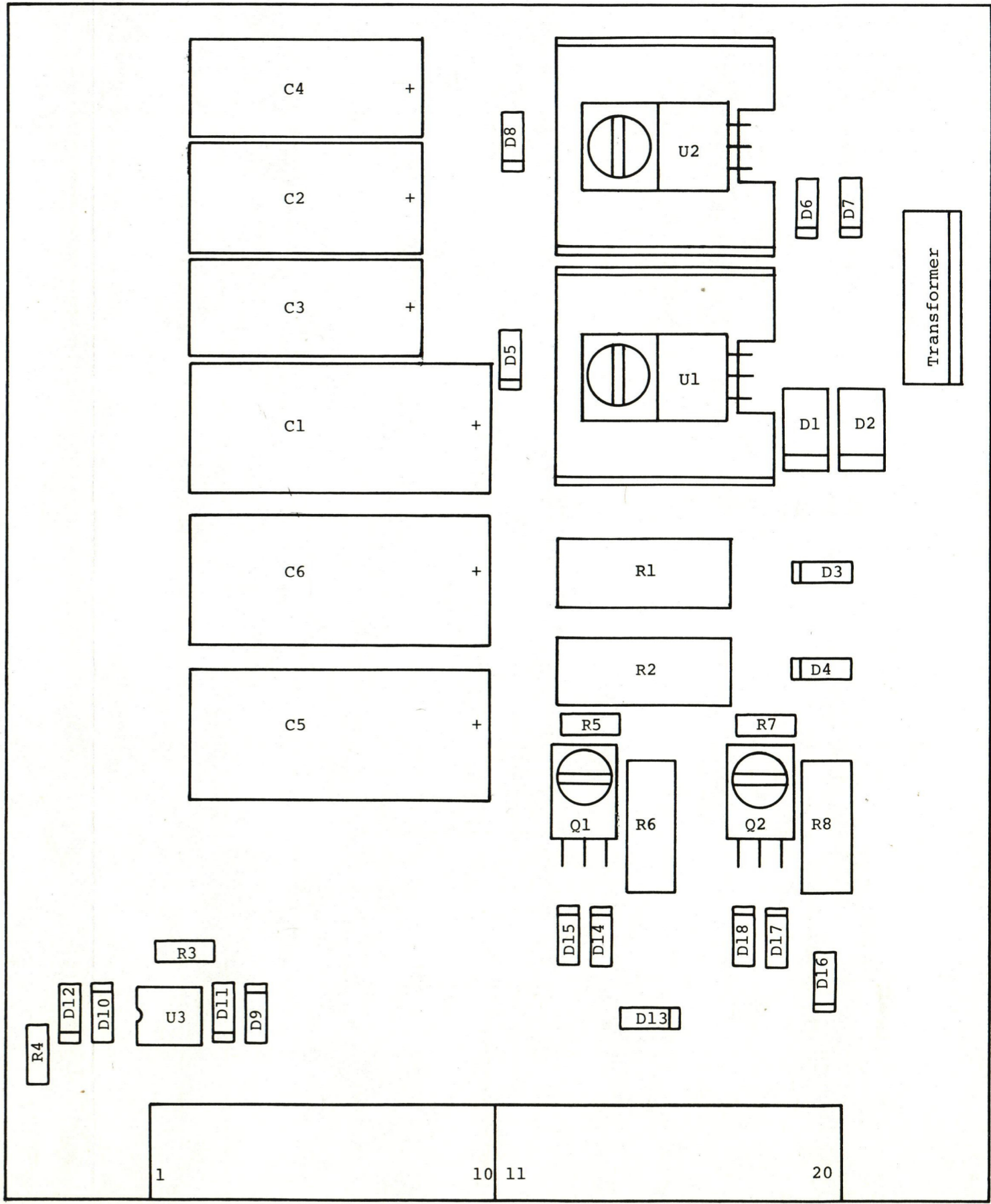

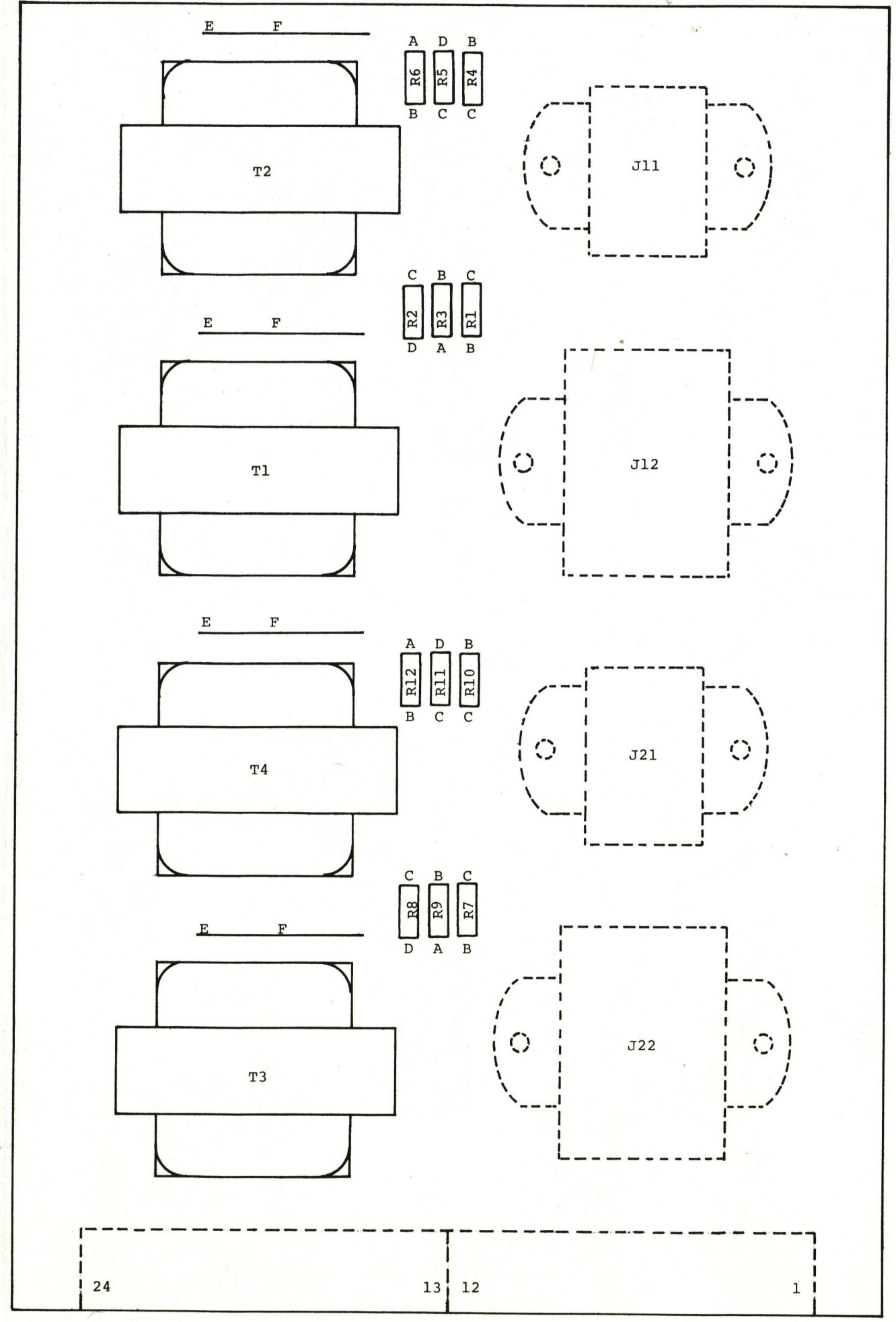
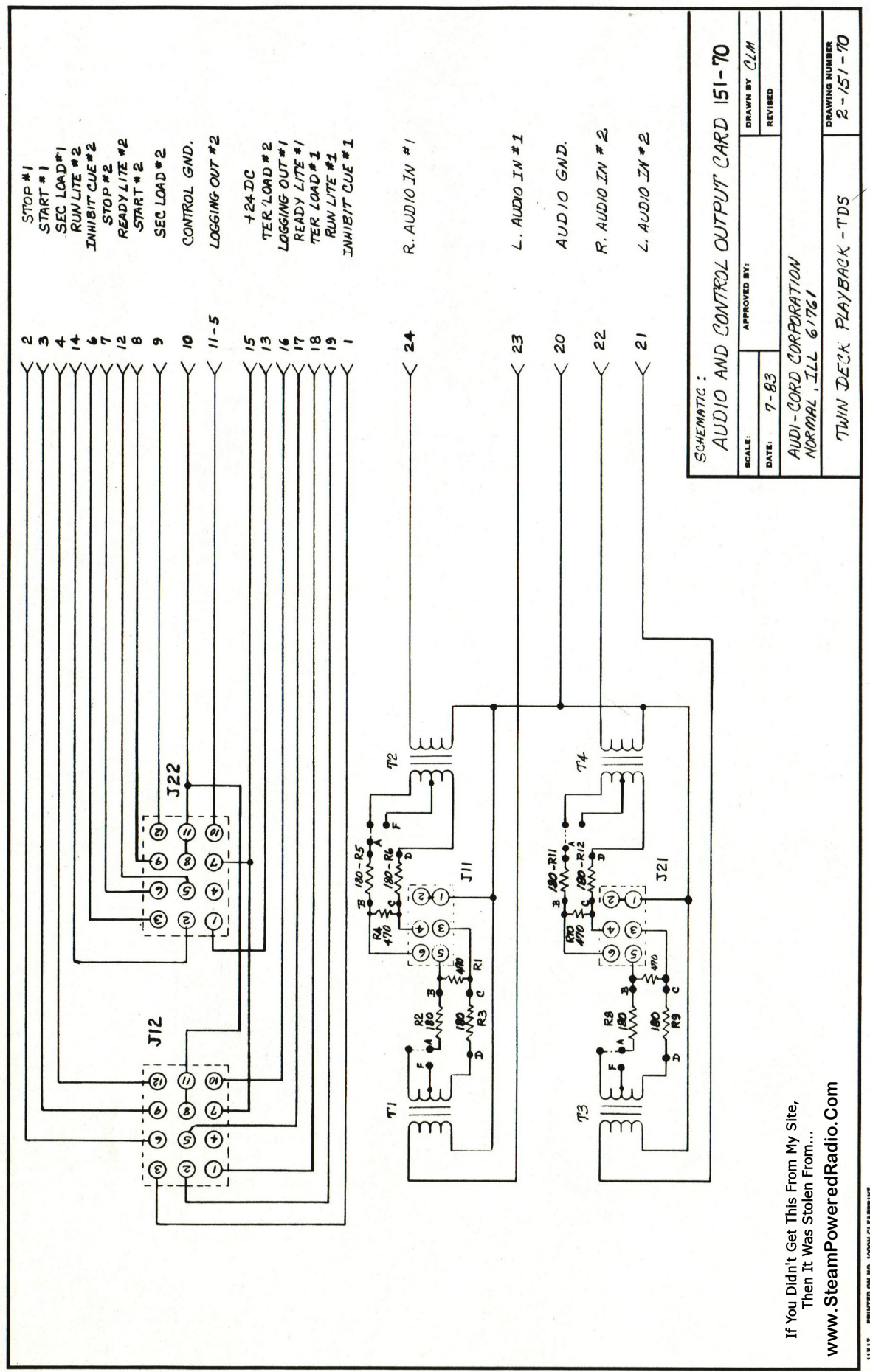

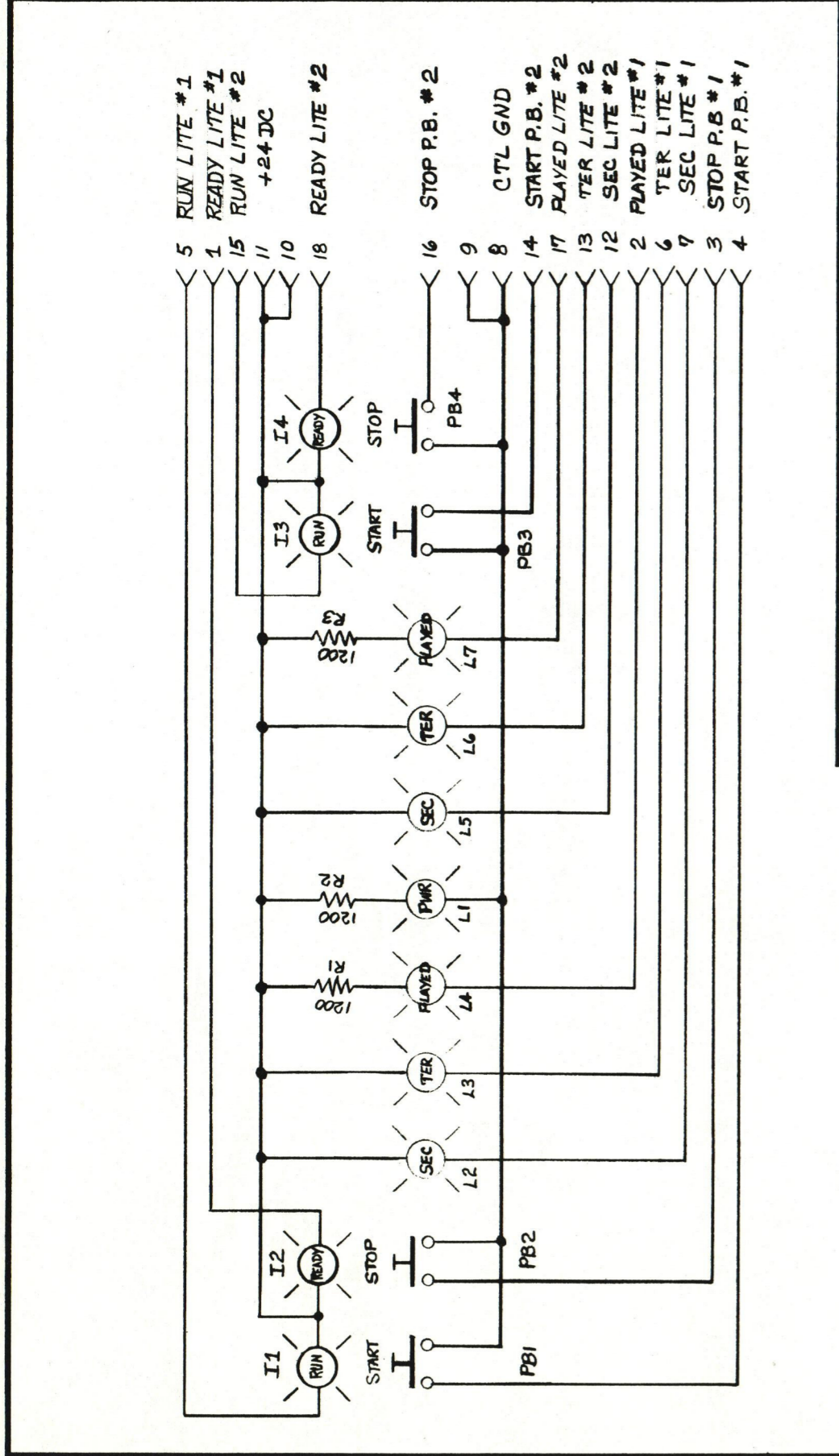

SCHEMATIC: FRONT PANEL CONTROL (CARD 151-72)

SCALE:	APPROVED BY:	DRAWN BY:
DATE: 7-83		GLM
AUDI-CORD CORPORATION NORMAL, ILL 61761		
TWIN DECK PLAYBACK		DRAWING NUMBER 1-151-72

ALL RESISTORS - 1200 Ω , 1/2 W.

If You Didn't Get This From My Site,
Then It Was Stolen From...
www.SteamPoweredRadio.Com

8 1/2 X 11 PRINTED ON NO. 1000H CLEARPRINT

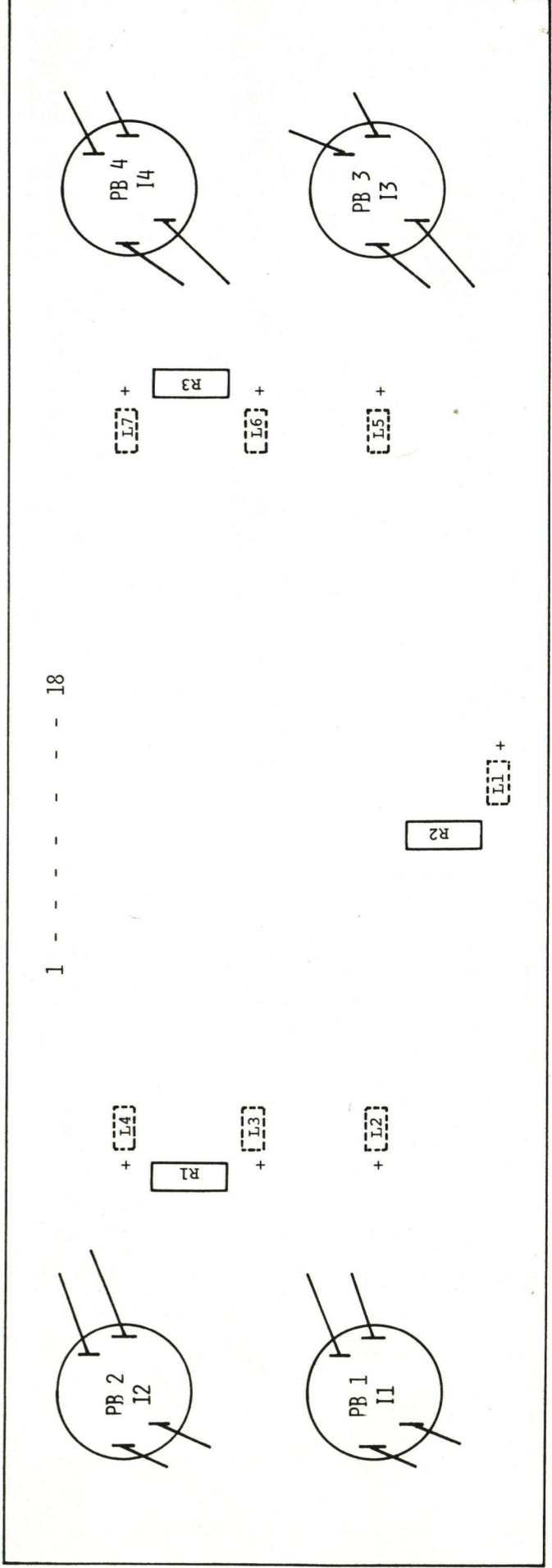

PUSHBUTTON & LAMP CARD 151-72

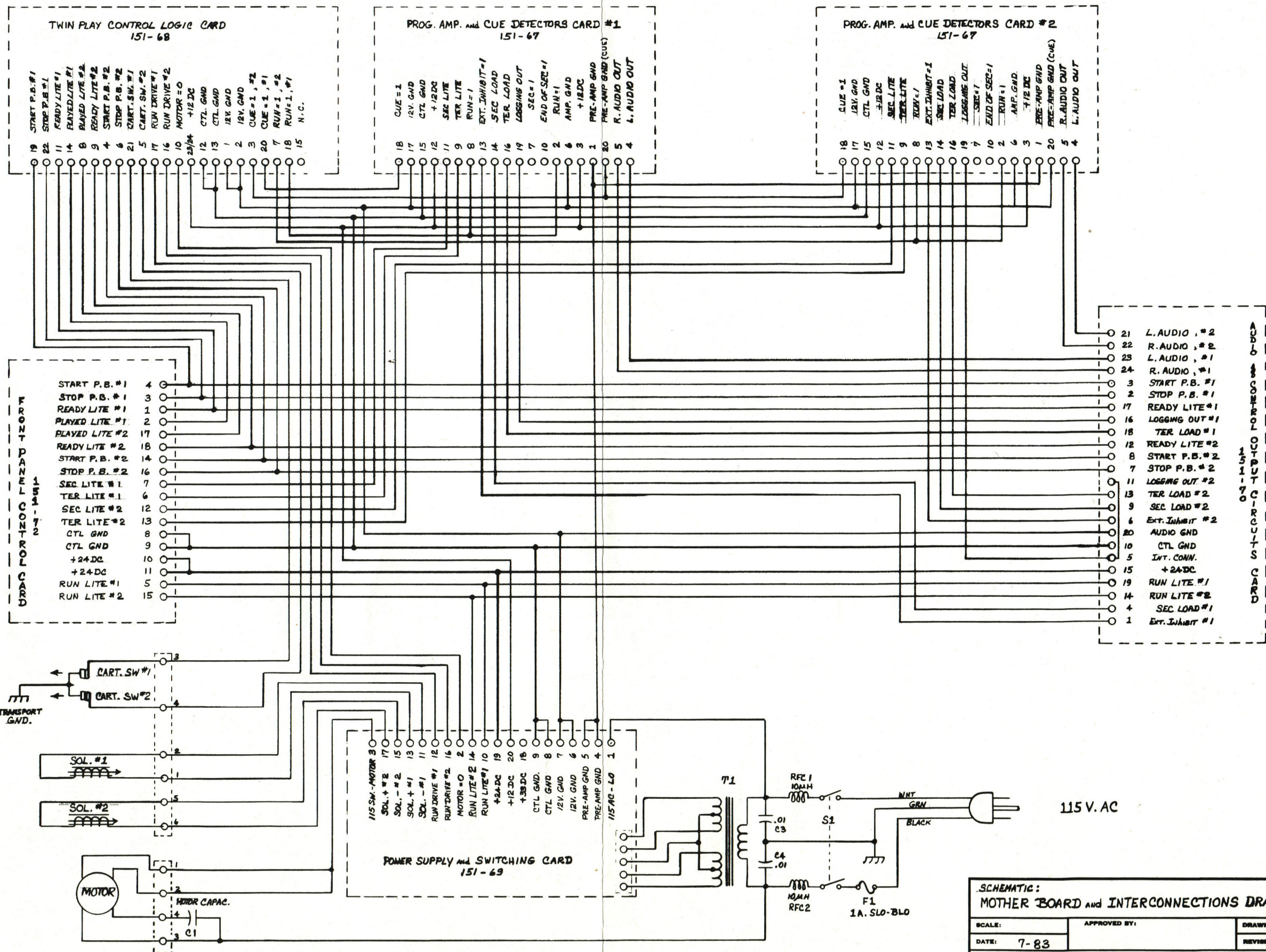

SCHEMATIC: MOTHER BOARD AND INTERCONNECTIONS DRAWING		
SCALE:	APPROVED BY:	DRAWN BY CLM
DATE: 7-83		REVISED
AUDI-CORD CORPORATION NORMAL, ILL. 61761		
TWIN DECK PLAYBACK		DRAWING NUMBER 3-151-71

If You Didn't Get This From My Site,
Then It Was Stolen From...
www.SteamPoweredRadio.Com

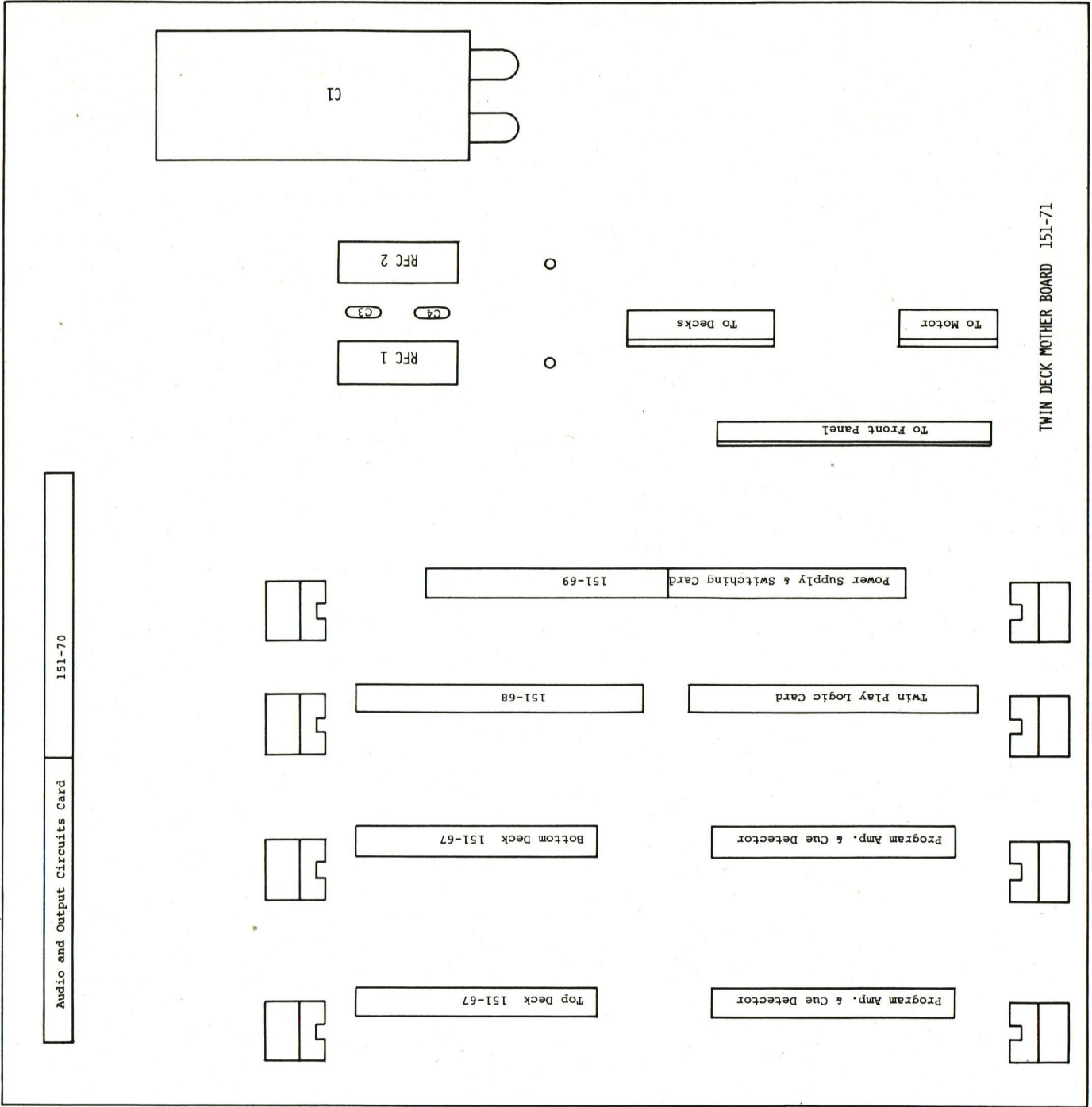

TWIN DECK MOTHER BOARD 151-71

