

Increductor® Notes #4

Published by TRAK ELECTRONICS COMPANY, Division of CGS Laboratories, Inc., 59 Danbury Road (Route 7), Wilton, Connecticut

Tuning receivers with controllable inductors / Part 1: Design of RF head

In an electronically tuned receiver, the INCREDUCTOR Controllable Inductor is used as the tunable element in the resonant circuits. Tuning is accomplished by varying the DC control current in the INCREDUCTOR unit, hence

changing the incremental inductance and thus the resonant frequency of the circuit. When combined with suitable control circuits, such INCREDUCTOR-tuned stages are ideally suited for panoramic, signal seeking and listening receivers.

System Considerations

INCREDUCTOR tuning can be employed in receivers operating up to 400 mc, and is most desirable in those applications that involve (a) maximum rejection of images and spurious signals, (b) a minimum of mechanical linkages in the tuning circuits, (c) rapid tuning, or (d) separation between control chassis and tuner chassis. Before considering the design of typical INCREDUCTOR-tuned receiver circuits, we will examine these applications in greater detail.

It is well known that receiver performance, in general, improves in proportion to the number of tuned stages employed in the RF head. With the mechanically tuned receiver, a practical limitation is imposed on the number of such stages by the necessity of physically ganging together and tracking all the tuned elements. However, in ganging an electronically tuned receiver, the INCREDUCTOR inductor control windings are connected in series and driven by a common control current. Since mechanical linkages are unnecessary, it becomes a relatively easy and economical matter to incorporate many more tuned stages in this electronically tuned receiver than in its mechanically tuned counterpart. Thus one obtains better sensitivity and rejection of images and spurious signals with no increase in control circuitry. An electronically tuned receiver, employing INCREDUCTOR-tuned circuits in the front end, can be designed for a noise figure on the order of 6 db and for image rejection of approximately—110 db.

Since controllable inductors have no moving parts, they are not subject to the problems created by friction and mechanical inertia. Hence, receivers incorporating these inductors can be tuned more rapidly than their mechanically tuned counterparts. This rapid scan feature is of particular interest in the ECM field where equipment must be designed for maximum probability of intercept and mini-

um lock-on time. In such cases, the maximum sweep speed is usually governed by the resolution required. The use of INCREDUCTOR units will permit sweeps well into the kilocycle region, and higher sweeps are possible if the control current source has the required power capability.

The controllable inductor approach to receiver design also enables the engineer to physically locate receiver sub-assemblies to the best advantage for the particular circuit and application involved. For example, placement of an INCREDUCTOR-tuned RF head directly at the termination of an antenna would eliminate all feed-line losses. In this example of remote operation, the only connection between the RF head and the remainder of the receiver would be

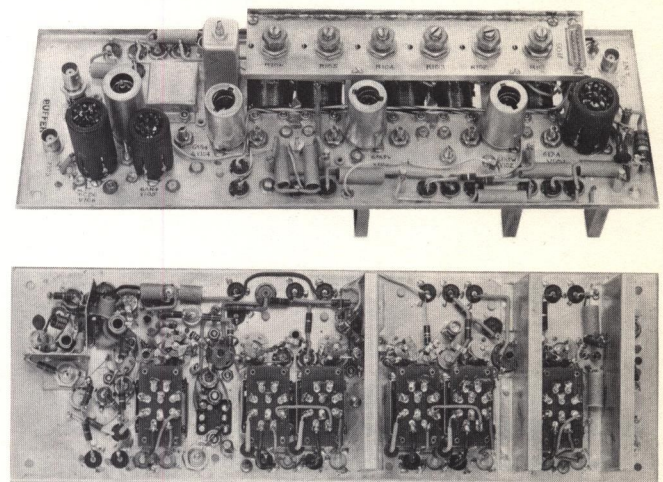

Figure 4-1. INCREDUCTOR-tuned RF head for the 100-150 mc range. Controllable inductor coils are visible in upper photo just below the potentiometers. Rectangular base plates of INCREDUCTOR units can be seen in lower photo.

a multiconductor cable carrying IF output, power and control voltages. Another example could be the placement of the control circuits of an aircraft receiver on the pilot's instrument panel with the remaining portions of the receiver placed in some less crowded location.

From the foregoing discussion, it is seen that the principal development effort can be divided into two categories — design of the RF head and design of the control circuitry. The complexity of each effort depends upon the number of functions the receiver is to perform. If one were to design a receiver to provide the combination of panoramic, signal seeking, and listening functions, the RF design would be relatively simple while the major design effort would be concentrated on the control circuitry. CGS Laboratories has developed control circuitry that can perform these three receiver functions, and in doing so has found practical solutions to the problems of hysteresis, temperature sensitivity, and non-linearity of frequency versus control current. A future issue of INCREDUCTOR Notes will discuss control circuitry in greater detail.

The remainder of this issue will be devoted to some factors involved in designing the RF heads incorporated in TRAK® Panoramic Receivers. A typical head is illustrated in figure 4-1. Model PAN-1C of this series of receivers possesses the following overall characteristics:

1. Frequency: 100-150 mc
2. Sweep Rate: 10 cps
3. Noise Figure: 6 db
4. Bandwidth: 30 kc
5. Sensitivity: 0.5 microvolt for 2:1 signal-to-noise ratio on cathode-ray tube
6. Dynamic Range: Over 60 db (with nearly logarithmic display)
7. Spurious Response: Over 60 db
8. Image Rejection: 100 db or more
9. Local Oscillator Radiation: A maximum of 2 microvolts at antenna terminals; not detectable at any other point.

INCREDUCTOR NOTES is published from time to time to keep you informed of progress in the development and use of high-frequency electrically controllable inductors. If this copy was mailed to you using an address plate, you will automatically receive future issues. If your address needs correcting, or if a friend would like to receive INCREDUCTOR NOTES, please clip the coupon to the right.

RF Circuit Description

A signal intercepted by the antenna is fed into the receiver front end (figure 4-2) where it is amplified by V101, a low-noise, high-gain, grounded-grid triode. A bandpass filter in the input circuit provides the necessary transfer characteristics between the antenna and the grounded grid stage over the range covered by the receiver. The tuned circuit in the plate of V101 consists of the signal winding of the controllable inductor CL101, and capacitor C117; resistor R138 loads the inductor to increase its bandwidth and maintain a uniform gain. (For simplicity of presentation, the INCREDUCTOR control and bias windings are shown at the top of the schematic, while the signal winding is shown in the plate circuit of the stage.) The parallel combination of R134 and L127 in the output circuit suppresses parasitic oscillations.

Two pentode RF amplifiers (V102 and V103) and a triode mixer (V104), all linked by double INCREDUCTOR-tuned interstage networks, follow the input stage. The controllable inductors in the tank circuits are individually packaged; there is no inductive coupling between INCREDUCTOR units. Each stage is linked to the next by L-C networks that provide an impedance common to the tuned circuits in each pair. Between the two pentode stages, a series resonant circuit (L116, C120, and C121), tuned slightly below the lowest frequency covered by the receiver, provides critical coupling and maximum gain at the low frequencies. Since the receiver operates above this resonant frequency, the circuit provides effectively inductive coupling. This gives decreasing coupling at increasing frequencies to offset the rising Q of the controllable inductors. In this manner, impedance and gain characteristics remain nearly constant over the range of the receiver.

A similar gain-bandwidth characteristic between V103 and V104 is obtained with a parallel L-C combination (L113 and C125) tuned slightly above the highest received frequency.

The triode mixer (V104) receives an output from the RF stages and from triode local oscillator V105, which is tuned by a controllable inductor identical to those found in the RF section. The mixer output is then fed directly to a 30-mc IF stepdown transformer which matches the coaxial cable connecting the RF and IF chassis.

Please send INCREDUCTOR NOTES to me at this address. This is a new corrected address.

(Maximum of five lines, please.)

Series and shunt tracking coils (L119 and L120) adjust the tuning range of the local oscillator over the 130-180 mc range required for operation with the 30-mc intermediate frequency. These tracking inductors are analogous to the series and shunt tracking capacitors used in the local oscillator of capacity-tuned receivers.

Tracking Considerations

All the INCREDUCTOR Inductor control windings are connected in series; although not shown on this schematic, the string of control windings is in the plate circuit of the pentode that supplies the control current. Diode CR101 and resistor R113 are placed across the string to limit the high voltage transients that would occur if the control current should be interrupted during operation. (This safety precaution is quite important as the resulting transients can be of a magnitude sufficient to permanently damage the control windings.)

The bias windings are connected so that the quiescent control current level of each inductor may be individually adjusted by means of a potentiometer. The bias winding thus sets the operating point, or operating inductance. Either temperature coefficient or hysteresis effect can be reduced by selection of a suitable operating point.

In addition to determining the operating point, the setting of the bias potentiometer also serves as one of the tracking adjustments; the other tracking adjustment is the padding capacitor which parallels the signal winding. As in conventional tracking adjustments, the capacitors are adjusted at the high end of the band and the inductors on

the low end. However, when using INCREDUCTOR Controllable Inductors, one adjusts the inductance by adjusting the bias currents as determined by the settings of potentiometers R101 through R105. The corresponding padding capacitors are C117, C119, C122, C124 and C126.

The local oscillator stage operates above the signal frequency, and is tracked by the combination of padding inductance L120, and padding capacitor C131 in conjunction with potentiometer R106.

The controllable inductor used in this RF head is CGS Laboratories former type XH-183 which has since been changed to type 81AP1. This unit incorporates a ferrite which is extremely stable and uniform and hence ideal for use in applications involving tracking. The total tracking error of this RF head is on the order of 1% or less of frequency.

Experiments at UHF Frequencies

Current experiments at higher frequencies show that INCREDUCTOR-tuned UHF receivers are feasible. While it is too early to publish any data on this development, future issues of INCREDUCTOR Notes will contain a discussion of design requirements and a catalog sheet describing new INCREDUCTOR units designed to operate in the UHF region.

If you should have an application that might be solved by use of INCREDUCTOR Controllable Inductors, let us hear from you. CGS Laboratories' experience and know-how would enable us to quickly determine feasibility and to offer suggestions that we feel would be helpful to you.

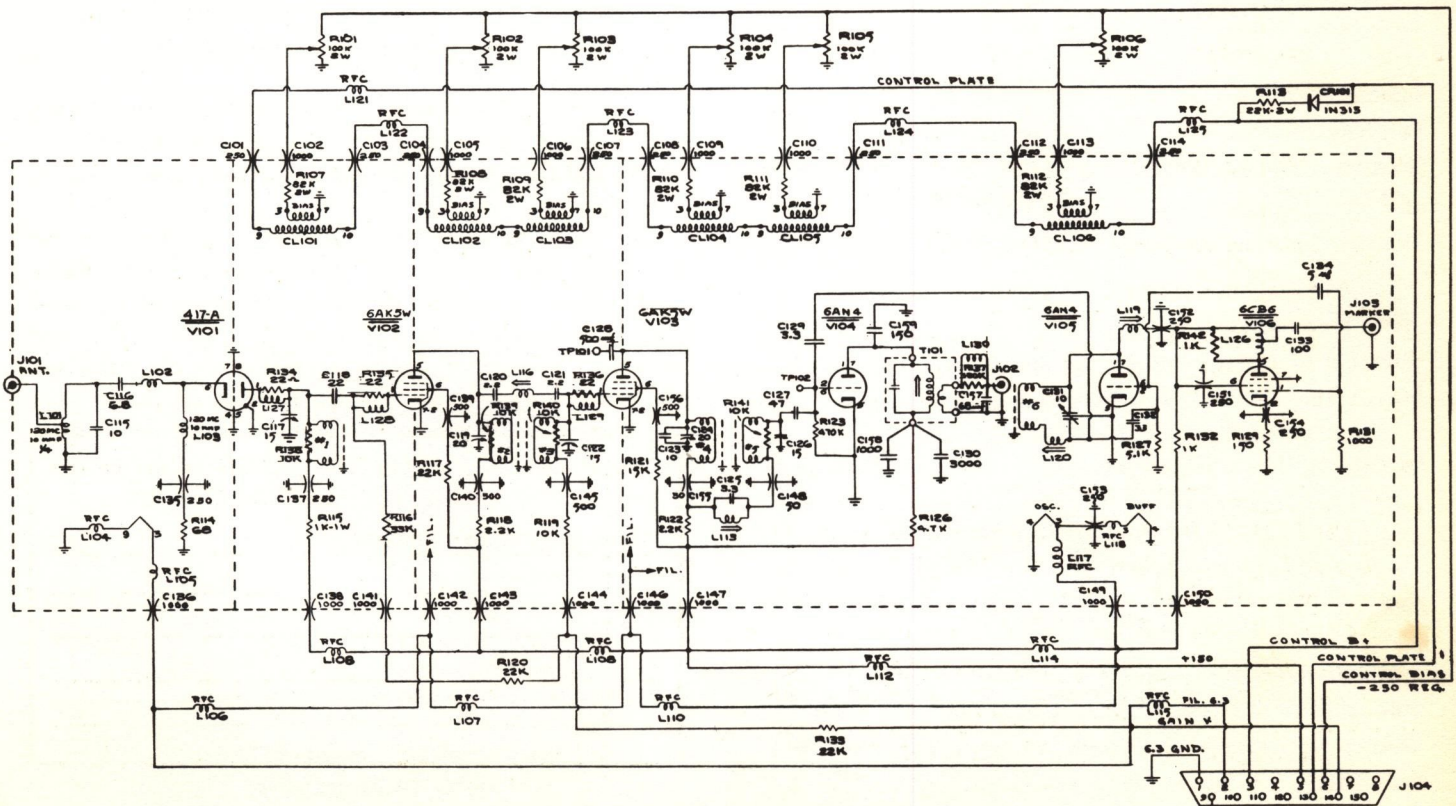

Figure 4-2. RF Head of TRAK® Panoramic Receiver, Model PAN-1C.

SERIES DQ

These INCREDUCTOR units are recommended for circuits in which the starting frequency is between 300 kilocycles and 5 megacycles. They provide control of inductance over a wide range. When used in tuned circuits, a frequency range of 5 to 1 is readily attained.

The core structure is shown in the sketch. The control winding is in two parts mounted on an iron yoke. The balanced signal winding is mounted on a ferrite ring positioned between the pole tips of the yoke. There is only limited variation in the inductance of the control winding over the operating range.

These units require only small amounts of driving power and are particularly useful where space and weight requirements are important. Each unit weighs only 130 grams.

SIGNAL WINDING	65DQ1	65DQ2	55DQ1
Nominal Maximum Inductance (μ h)	25	100	500
Available Inductance Change Ratio	36:1	36:1	36:1
Maximum Q	70	100	70
Starting Frequency Range (mc)	1-5	0.7-2.0	0.3-1.0
Capacity to Electrostatic Shield (μ mf)	3	6	12

Control Winding—The control winding has a maximum nominal inductance of 6 henries and a d-c resistance of 325 ohms. The maximum peak control current is 100 ma, and the maximum average current should not exceed 70 ma.

Bias Winding—The bias winding has a maximum inductance of 1 henry and d-c resistance of 200 ohms. The bias current should not exceed 15 ma.

Packaging—These units are housed in hermetically sealed cans. Connections are made to the base plate by means of solder lugs.

Tracked Sets

Where it is desired to track a number of INCREDUCTOR units, it is recommended that special precision units be ordered as a group. Such units are specified by adding the suffix "P" to the above designations.

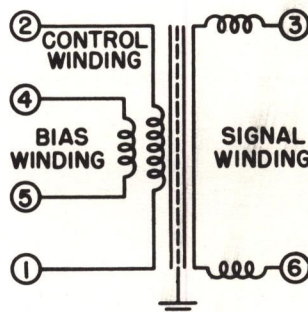
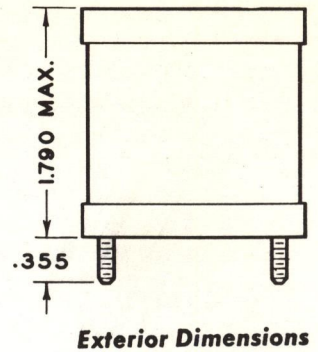
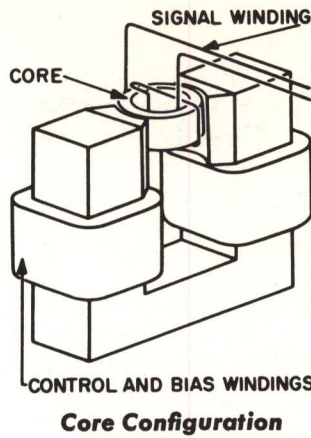

Circuit Diagram

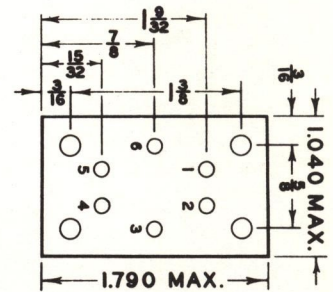

Base Diagram

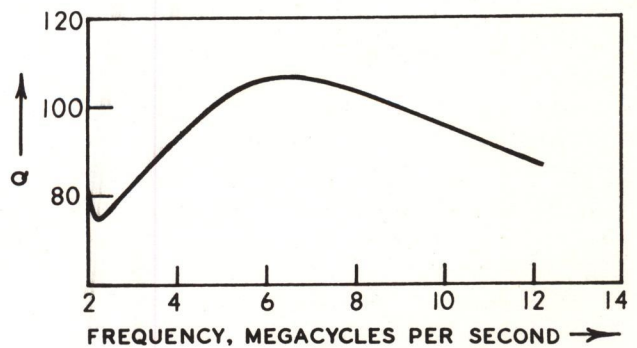

Q Characteristics

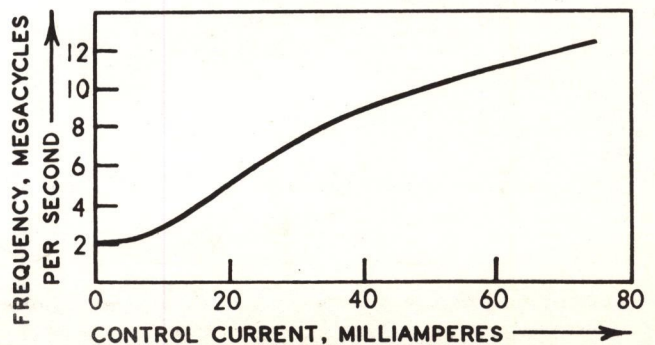

Control Characteristics