

# YAMAHA RX-530 *RS*

*Natural Sound Stereo Receiver*

*50W + 50W (8Ω) RMS Output Power, 0.02%THD, 20-20,000 Hz*

*16-Station Random Preset Tuning*

*IF Count Direct PLL Synthesizer Tuning System*

*Continuously Variable Loudness Control*

*Rec-out Selector*

*CD Direct Switch, Bass Extension*

*Wireless Remote Control Capability*

*Thank you for selecting the YAMAHA model RX-530 Stereo Receiver.*

## CONTENTS

Safety Instructions .....	2
Caution .....	3
Supplied Accessories .....	8
Control Parts and Their Functions .....	8
Connections .....	10
Operations .....	12
Remote Control Transmitter .....	13
Specifications .....	15
Troubleshooting .....	16

If You Didn't Get This From My Site,  
Then It Was Stolen From...

[www.SteamPoweredRadio.Com](http://www.SteamPoweredRadio.Com)

**OWNER'S MANUAL**



### IMPORTANT!

Please make a note of the serial number of this unit in the space indicated below.

Model: **RX-530**  
Serial No.:

The serial number is inscribed on the rear of the unit. Keep this Owner's Manual in a safe place for future reference.



## SAFETY INSTRUCTIONS

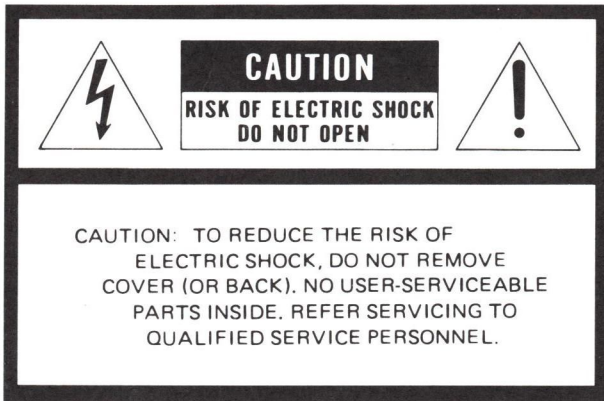

- Explanation of Graphical Symbols



The lightning flash with arrowhead symbol, within an equilateral triangle, is intended to alert you to the presence of uninsulated "dangerous voltage" within the product's enclosure that may be of sufficient magnitude to constitute a risk of electric shock to persons.



The exclamation point within an equilateral triangle is intended to alert you to the presence of important operating and maintenance (servicing) instructions in the literature accompanying the appliance.

### WARNING

To reduce the risk of fire or electric shock, do not expose this appliance to rain or moisture.

**1** Read Instructions – All the safety and operating instructions should be read before the appliance is operated.

**2** Retain Instructions – The safety and operating instructions should be retained for future reference.

**3** Heed Warnings – All warnings on the appliance and in the operating instructions should be adhered to.

**4** Follow Instructions – All operating and other instructions should be followed.

**5** Water and Moisture – The appliance should not be used near water – for example, near a bathtub, washbowl, kitchen sink, laundry tub, in a wet basement, or near a swimming pool, etc.

**6** Carts and Stands – The appliance should be used only with a cart or stand that is recommended by the manufacturer.

**6A** An appliance and cart combination should be moved with care. Quick stops, excessive force, and uneven surfaces may cause the appliance and cart combination to overturn.



**7** Wall or Ceiling Mounting – The appliance should be mounted to a wall or ceiling only as recommended by the manufacturer.

**8** Ventilation – The appliance should be situated so that its location or position does not interfere with its proper ventilation. For example, the appliance should not be situated on a bed, sofa, rug, or similar surface, that may block the ventilation openings; or placed in a built-in installation, such as a bookcase or cabinet that may impede the flow of air through the ventilation openings.

**9** Heat – The appliance should be situated away from heat sources such as radiators, stoves, or other appliances that produce heat.

**10** Power Sources – The appliance should be connected to a power supply only of the type described in the operating instructions or as marked on the appliance.

**11** Power-Cord Protection – Power-supply cords should be routed so that they are not likely to be walked on or pinched by items placed upon or against them, paying particular attention to cords at plugs, convenience receptacles, and the point where they exit from the appliance.

**12** Cleaning – The appliance should be cleaned only as recommended by the manufacturer.

**13** Nonuse Periods – The power cord of the appliance should be unplugged from the outlet when left unused for a long period of time.

**14** Object and Liquid Entry – Care should be taken so that objects do not fall into and liquids are not spilled into the inside of the appliance.

**CAUTION : READ THIS BEFORE  
OPERATING YOUR UNIT**

**15** Damage Requiring Service – The appliance should be serviced by qualified service personnel when:

- A.** The power-supply cord or the plug has been damaged; or
- B.** Objects have fallen, or liquid has been spilled into the appliance; or
- C.** The appliance has been exposed to rain; or
- D.** The appliance does not appear to operate normally or exhibits a marked change in performance; or
- E.** The appliance has been dropped, or the cabinet damaged.

**16** Servicing – The user should not attempt to service the appliance beyond those means described in the operating instructions. All other servicing should be referred to qualified service personnel.

**17** Power Lines – An outdoor antenna should be located away from power lines.

**18** Grounding or Polarization – The precautions that should be taken so that the grounding or polarization of an appliance is not defeated.

**19** Outdoor Antenna Grounding – If an outside antenna is connected to the receiver, be sure the antenna system is grounded so as to provide some protection against voltage surges and built up static charges.

Section 810 of the National Electrical Code, ANSI/NFPA No. 70-1984, provides information with respect to proper grounding of the mast and supporting structure, grounding of the lead-in wire to an antenna discharge unit, size of grounding conductors, location of antenna-discharge unit, connection to grounding electrodes, and requirements for the grounding electrode.

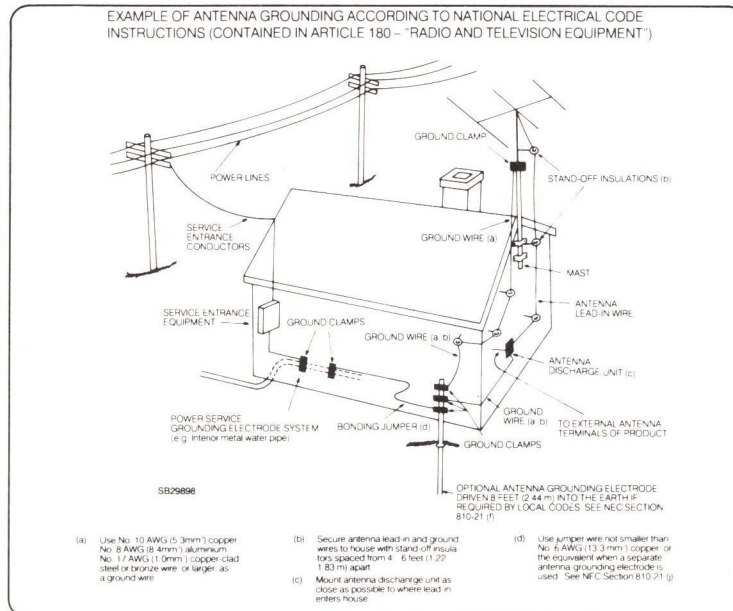

- 1.** This unit is a sophisticated receiver. To ensure proper operation for the best possible performance, please read this manual carefully.
- 2.** Choose the installation location of this unit carefully. Avoid placing it in direct sunlight or close to a source of heat. Also avoid locations subject to vibration and excessive dust, heat, cold or moisture. Keep it away from such sources of hum as transformers or motors.
- 3.** Do not open the cabinet as this might result in damage to the set, or electrical shock. If a foreign object should get into the set, contact your dealer.
- 4.** To prevent lightning damage, pull out the power cord and remove the antenna cable during an electrical storm.
- 5.** When removing the power plug from the wall outlet, always pull directly on the plug; never pull the cord itself.
- 6.** Do not use force when using the switches.
- 7.** When moving the set be sure to first pull out the power plug and remove cords connected to other equipment.
- 8.** Do not attempt to clean this unit with chemical solvent as this might damage the finish. Use a clean, dry cloth.
- 9.** Be sure to read the "Troubleshooting" section for advice on common operating errors before concluding that this unit is faulty.
- 10.** Keep this manual in a safe place for future reference.

**1 SUPPLIED ACCESSORIES**

● Remote Control Transmitter

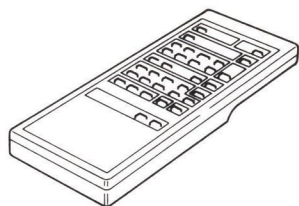

● Batteries (size "AAA" R03)

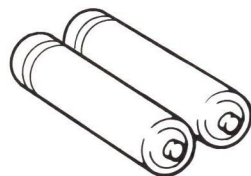

● AM Loop Antenna

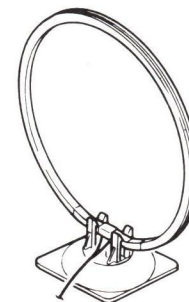

● Indoor FM Antenna

(U.S.A., Canada, Australia, U.K. and General models)

(Europe model)

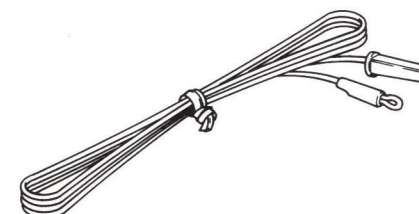
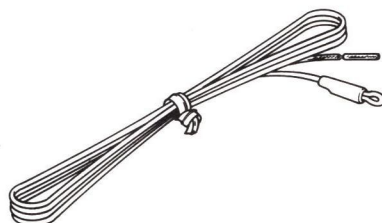

● Remote Control Cable (6-pin. cassette deck)

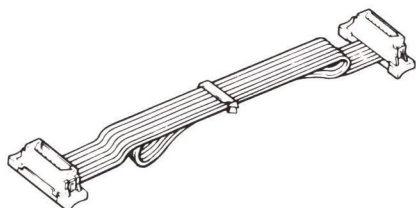

● Remote Control Cable (mini-plug, turntable)

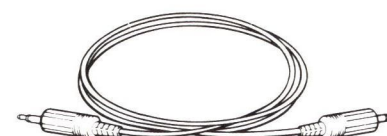



## 2 FRONT PANEL

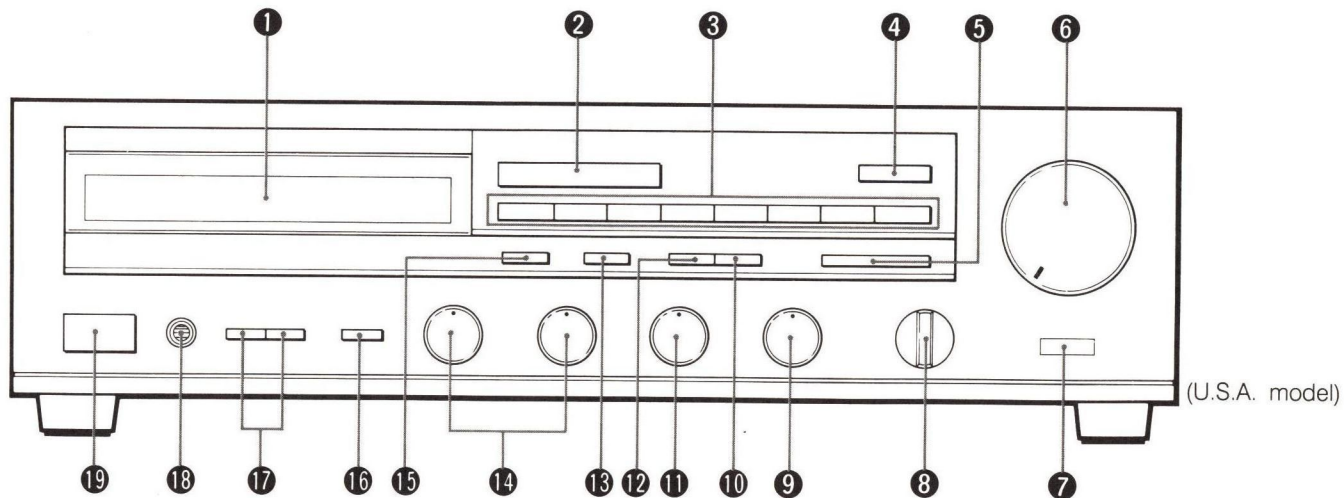

### 1 Display window

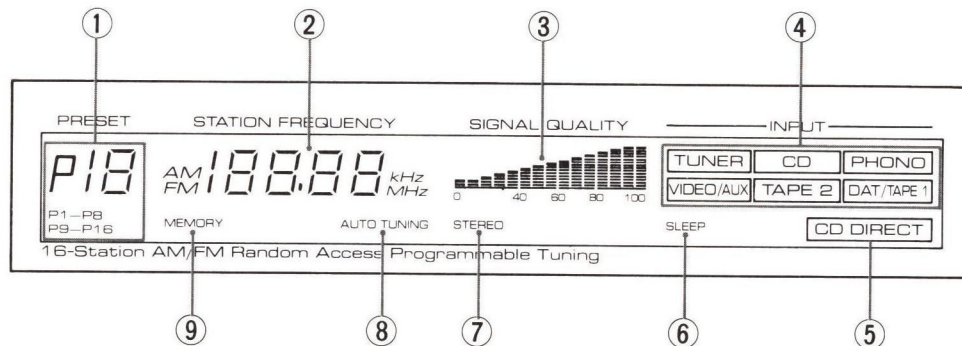

## REAR PANEL

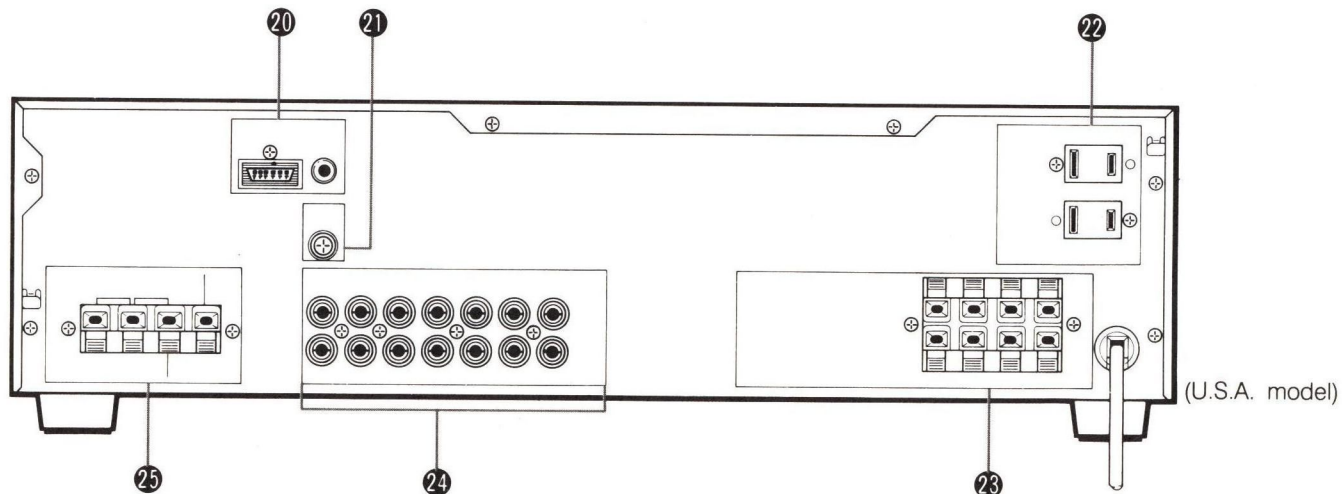

### 3 ANTENNA CONNECTIONS

#### U.S.A., CANADA, AUSTRALIA, U.K. AND GENERAL MODELS

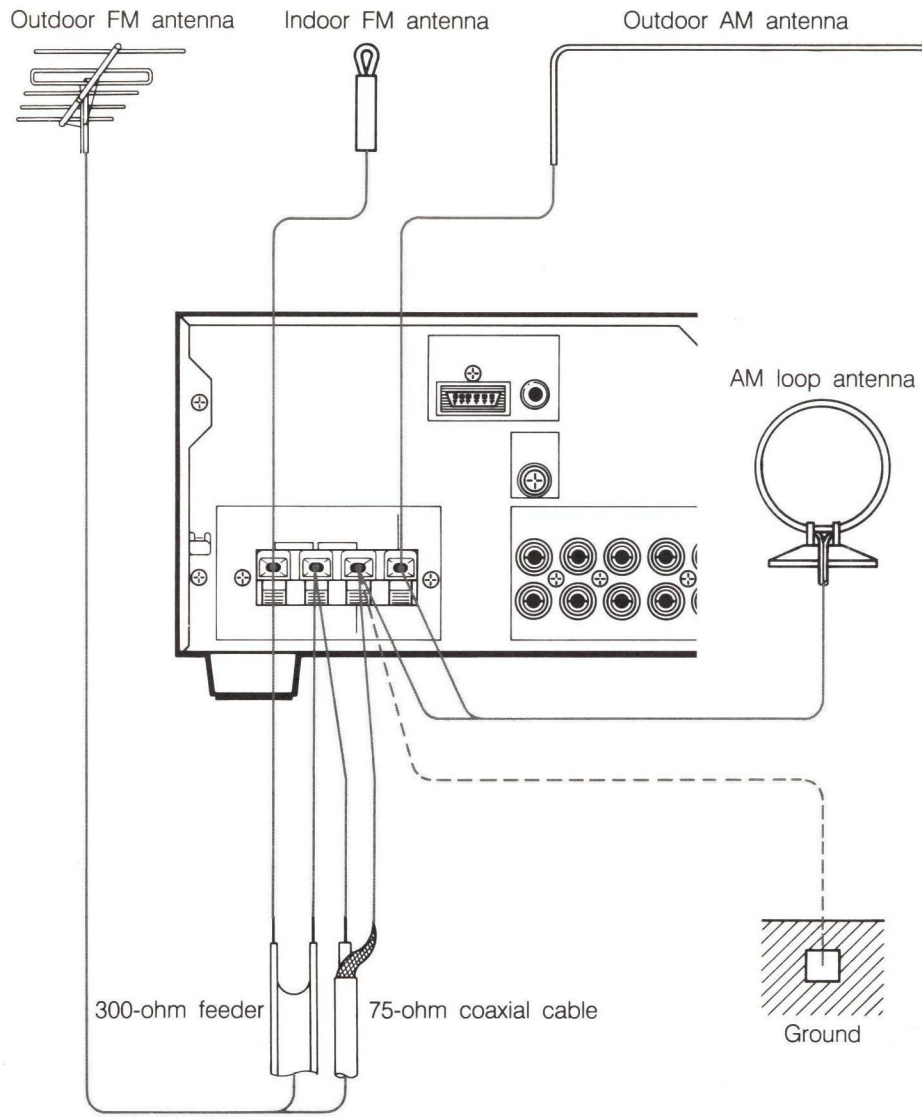

#### EUROPE MODEL

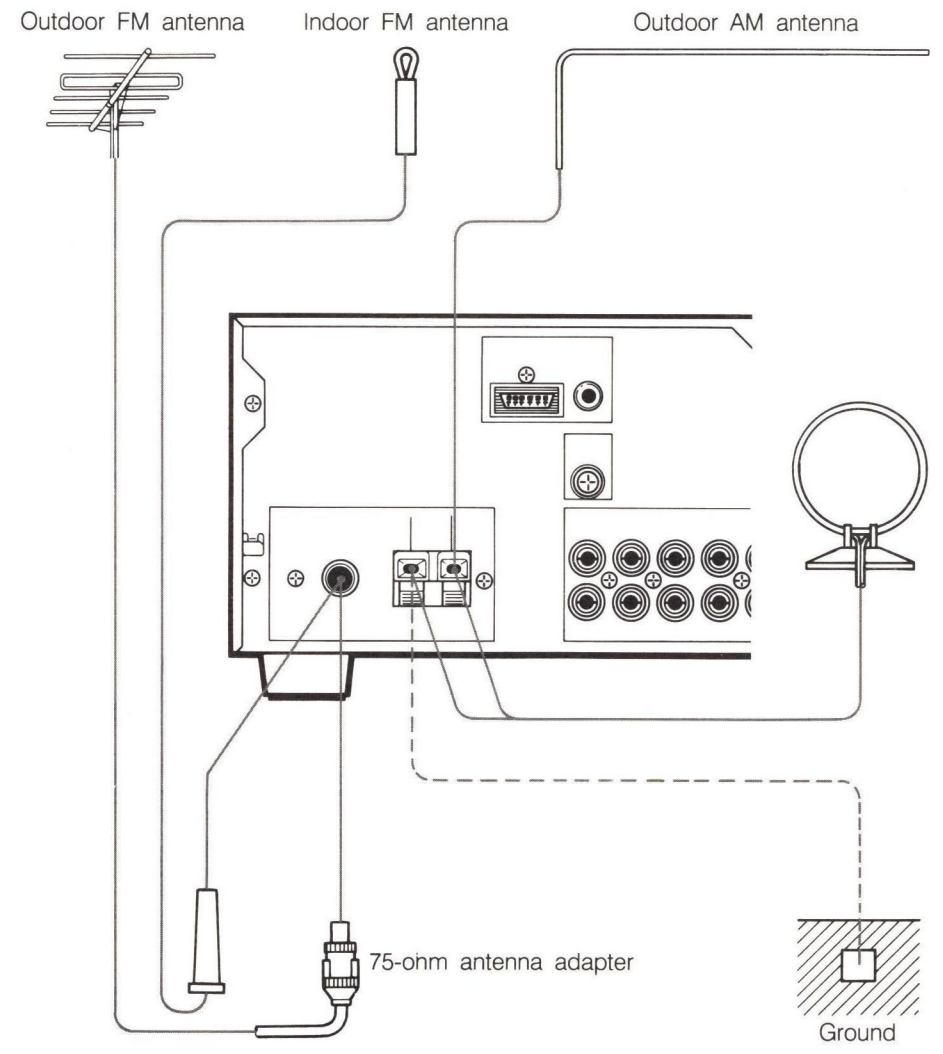



## 4 AUDIO CONNECTIONS

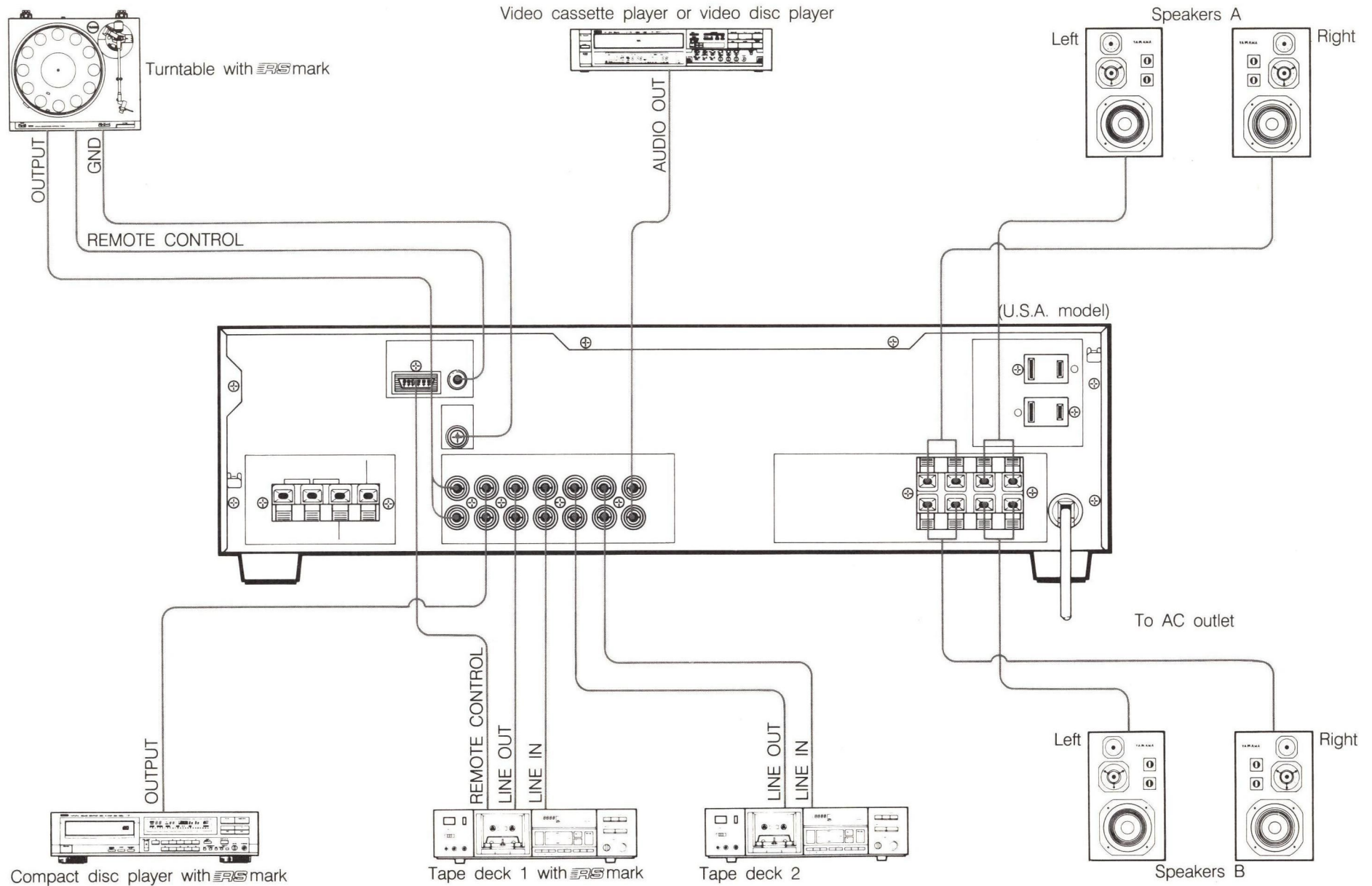

## SUPPLIED ACCESSORIES

(See Fig. 1.)

After unpacking, check that the following parts are contained.

- Remote control transmitter
- Batteries
- Remote control cable (6-pin)
- Remote control cable (mini-plug)
- AM loop antenna
- Indoor FM antenna

## CONTROL PARTS AND THEIR FUNCTIONS

(See Fig. 2.)

### FRONT PANEL

#### ① Display window

##### ① PRESET display

###### Preset station indicator

Lights up to indicate the pressed preset station button.

###### P1-P8/P9-P16 indicators

Indicates the range (either P1-P8 or P9-P16) of selectable preset station buttons.

##### ② STATION FREQUENCY display

Displays the band and frequency of the received radio signal.

##### ③ SIGNAL QUALITY indicators

These indicators display the signal strength of the tuned frequency in bar-graph form. 0 marks a poor or no signal, while 100 indicates an excellent signal.

##### ④ INPUT indicator

Indicates the program source selected by the Input selector.

##### ⑤ CD DIRECT indicator

Lights up while the CD DIRECT switch is set to ON.

##### ⑥ SLEEP indicator

This indicator illuminates beginning from the time that the SLEEP key of the remote-control transmitter is pressed and until the SLEEP mode is automatically canceled one hour later.

##### ⑦ STEREO indicator

When an FM stereo signal of sufficient strength is received the STEREO indicator lights up.

##### ⑧ AUTO TUNING indicator

When the tuner is in automatic tuning mode, the AUTO TUNING indicator lights.

##### ⑨ MEMORY indicator

When the MEMORY button is pressed, the MEMORY indicator blinks on and off.

#### ② Input selector (INPUT SELECTOR)

Used to select the program source to be heard. The selected program source is indicated in the display.

#### ③ Preset station buttons

Up to 16 station frequencies and reception modes can be stored using the preset station button.

#### ④ CD DIRECT switch (CD DIRECT)

This switch allows you to route the CD input signal directly to the output stage bypassing the INPUT selector, LOUDNESS, and BALANCE controls therefore avoiding any "muddying" caused by the switch and circuit routing to provide a pure sound.

#### ⑤ TUNING button

Press either side of the TUNING button to carry out auto or manual tuning.

#### ⑥ VOLUME control

This control is used to raise or lower the output volume level.

#### ⑦ REMOTE CONTROL sensor

This is used to receive signals from the remote control transmitter.

#### ⑧ REC OUT selector

Used to select the program source to be recorded.



### 9 Continuous variable LOUDNESS control

This control allows you to retain full tonal range at any volume levels. Your ear loses sensitivity to high and low frequency ranges at low volume settings. This control provides an equalization curve based on human hearing.

To adjust the LOUDNESS control to your listening level, first, set the control to the FLAT position, increase the VOLUME control to your loudest listening level, then turn the LOUDNESS control counterclockwise to reduce the volume level.

### TUNING MODE button

Used to select the tuning mode between AUTO and MAN'L FM MONO. In the MAN'L FM MONO mode, an FM stereo broadcasting is received in monaural.

### 11 BALANCE control

Use this control to concurrently change the left and right output volume to the speaker terminals to compensate for sound imbalance caused from speaker settings or listening room condition.

### 12 FM/AM button

Press this button to select the reception band between FM and AM.

### 13 MEMORY button

When this button is pressed, the MEMORY indicator flickers in the display for about 5 seconds. During this period, press the desired preset station button to store the displayed frequency.

### 14 Tone controls

#### BASS

Used to increase or decrease the low frequency response. The DEFEAT position produces flat response.

#### TREBLE

Used to increase or decrease the high frequency response. The DEFEAT position produces flat response.

### 15 P1-P8/P9-P16 button

Press this button to change the range of preset station buttons. When this button is pressed, the selected range of the P1-P8/P9-P16 indicators flickers for about 5 seconds.

### 16 BASS EXTENSION button

Pressing this button boosts bass response while maintaining overall tonal balance. This is useful to compensate for speakers with weak bass or a listening environment that deadens the bass.

### 17 SPEAKERS selectors

Set this selector to select the speakers to be driven.

### 18 PHONES jack

Plug in the headphones to this jack. To shut off the sound from the speakers, set the SPEAKERS selectors to OFF.

### 19 POWER switch

Press this switch to turn the power on. Press the switch again to turn the power off.

#### STANDBY indicator (Europe model only)

When this indicator is lit, remote control operation is possible.

## REAR PANEL

### 20 REMOTE CONTROL connectors

Use these to connect compatible YAMAHA components (with an  mark) to your receiver for remote control of each component.

#### TAPE 1/2

Connect to a cassette tape deck using the cable with 6-pin connector.

#### PHONO

Connect to a turntable using the cable with a mini-plug connectors.

### 21 GND terminal

Connect the ground wire of a turntable.

### 22 AC OUTLETS

Use these to connect the power cords from your components to the receiver.

The power to the SWITCHED outlets is controlled by the receiver's POWER switch or remote control transmitter's POWER key. They will supply power to any component whenever this unit is turned on.

The power to the UNSWITCHED outlet is not controlled by the receiver. It will continually supply power to any unit connected.

The maximum power that can be connected to the SWITCHED AC OUTLET is 100 watts and to the UNSWITCHED AC OUTLET (U.S.A., Canada and General models only) is 200 watts.

### 23 SPEAKERS terminals

Two pairs of speakers A and B can be connected to these terminals.

## CONNECTIONS

### 24 Audio signal connection jacks

Use these to connect the audio signal cords from your components to the receiver. They should be connected to the proper input/output jacks for each unit. Be sure that L and R channels are connected consistently.

#### VIDEO/AUX

These jacks can be used to make connections from a video cassette player or video disc player. These jacks can also be used as auxiliary input jacks for other equipment.

#### TAPE 2

Connect an audio signal of the second tape deck for both recording and playback.

#### DAT/TAPE 1

Connect a first tape deck for both recording and playback.

#### CD

Connect a compact disc player.

#### PHONO

Connect a turntable.

### 25 Antenna terminals

Connect an FM and AM antennas to these terminals.

### NOTES ON CONNECTIONS

- Be sure to turn off the power to all units before making any connections.

### ANTENNA CONNECTIONS

(See Fig. 3.)

#### • AM loop antenna

Connect the AM loop antenna cords to the AM ANT and GND terminals.

- ① Depress the tabs of AM ANT terminals.
- ② Connect the AM loop antenna leads to the AM ANT terminals.
- ③ Release the tabs. Lightly pull on the leads to confirm a good connection.

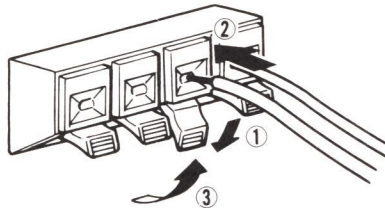

- ④ Attach the loop antenna to the antenna stand.

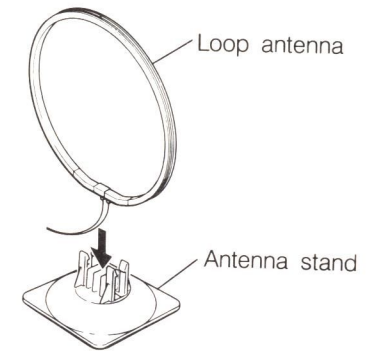

- ⑤ Orient the AM loop antenna so that the best reception is obtained.

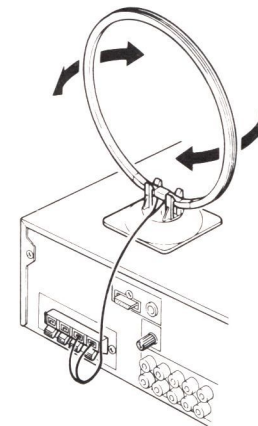

\* The antenna may be hung on a wall.

#### • Outdoor AM antenna

The end of the wire should be stripped of insulation and connected to the AM ANT terminal. At this time, keep the loop antenna connected.



- **Supplied indoor FM antenna**

(U.S.A., Canada, Australia, U.K. and General models)  
Connect the supplied indoor antenna to either of the 300  $\Omega$  BAL. FM ANT terminals. Move the antenna for best reception.

(Europe Model)

Connect the supplied indoor antenna to the 75  $\Omega$  UNBAL. FM ANT terminal.

\* Insert so that the grooved part of the connector hole is facing downward when the connection is made.

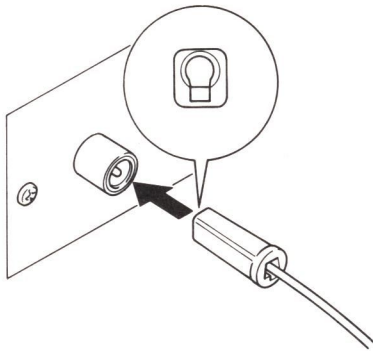

- **Outdoor FM antenna**

If necessary an outdoor FM antenna may be used for improved FM reception. Either 300-ohm feeder or coaxial cable may be used. In locations troubled by electrical interference, coaxial cable is preferable.

### **FREQUENCY STEP switch**

(General model only)

As the interstation frequency spacing differs in different areas, set the FREQUENCY STEP switch located at the rear according to the frequency spacing in your area.

## **AUDIO CONNECTIONS**

(See Fig. 4.)

- **Power cord**

Connect the power cord of your receiver to an AC outlet.

- **Speakers**

Connect the SPEAKERS terminals to your speakers with the proper gauge of wire, cut to be as short as possible. Press the speaker wire terminal tabs down, then insert the bare wires and secure them by releasing the tabs. If these connections are faulty, no sound will be heard from the speakers. Make sure that the polarity of the speaker wires is correct, that is, that the + and - markings are observed. If these wires are reversed, the sound will be unnatural and will lack bass. Do not coil up excess speaker wire or bundle the speaker cables with the power cords.

- **Turntable**

Connect the output cords of the turntable to the PHONO jacks, and connect the ground cord to the GND terminal. This should produce minimum hum, but in some cases better results are obtained with this cord disconnected.

- **Compact disc player**

Connect the output jacks of the compact disc player to the CD jacks.

- **Video cassette player etc.**

Connect the audio output jacks from a video cassette player, a CDV player or a video disc player to the VIDEO/AUX jacks.

- **Tape deck 1**

Connect the cords from a cassette deck to the DAT/TAPE 1 jacks. The playback (LINE OUT) jacks go to the TAPE PB jacks, and the record (LINE IN) jacks go to the REC OUT jacks.

- **Tape deck 2**

Connect the audio jacks of a second cassette deck to the TAPE 2 jacks in the same way.

- **Remote control cable**

The REMOTE CONTROL connectors are used when you have YAMAHA compatible components (with an *RS* mark).

These connections allow you to control the components from the supplied remote control transmitter.

Connect the remote control cables from the components to the correct connectors on your receiver (i.e. PHONO, TAPE 1/2).

Note that no cable is necessary for a compatible CD player, or a compatible cassette deck which has a remote control sensor as the remote control transmitter operates the player directly.

## TO LISTEN TO RADIO PROGRAM

### Auto Tuning

If signals are strong and there is no interference, quick automatic search tuning is possible.

1. Select the reception band with FM/AM button.
2. Press the TUNING MODE button so that the AUTO TUNING indicator lights up.
3. Use the TUNING button to tune.  
The tuning will start automatically and stop at broadcast station frequency with a sufficient signal strength.
4. If the station where tuning stops is not the one you want, press the TUNING button once again.

### Manual Tuning

Auto tuning may be impossible if the station signal is weak. If so, use manual tuning.

1. Select the reception band with FM/AM button.
2. Press the TUNING MODE button so that the AUTO TUNING indicator goes off.
3. Use the TUNING button to tune.  
The frequency will change rapidly if the TUNING button is kept pressed. Release it slightly before reaching the desired frequency, and then press it intermittently until the desired frequency is reached.

### Preset Tuning

The preset station button can be used to select, at a single touch, any desired station which has been preset.

1. Tune to the desired station using auto or manual tuning mode.
2. Select the range of the preset station button with the P1-P8/P9-P16 button.

3. Press the MEMORY button and then while the MEMORY indicator is flickering, press the desired preset station button.

### Note

If tuning is done in the manual mode and then MEMORY button is pressed, the preset tuning will be in Mono. Therefore prior to pressing MEMORY button, the tuning should be set to AUTO.

4. To receive the preset station, select the range of the preset station with the P1-P8/P9-P16 button and press the desired preset station button.
- Follow the same procedure for other preset station buttons.  
The new setting will be programmed in place of the former one.

### Memory back-up

The memory back-up circuit will prevent the programmed information from being lost even though the power is switched OFF for timer use or other temporary power failure. If, however, the unit is not used for a long time, the memory may be erased. If so, it can be re-programmed by simply following the original procedure.

## TO PLAY PROGRAM SOURCE

1. Select the program source to be heard with the input selector.
2. Play the program source.
3. Adjust the VOLUME and tone controls.

## TO RECORD PROGRAM SOURCE

1. Select the program source to be recorded with the REC OUT selector.
2. To listen to program source to be recorded, press the corresponding input selector.
3. Play the program source to be recorded and set the tape deck to record mode.

4. To listen to other program source during recording, select the program source to be listened to with the input selector.

When your tape deck has three head monitoring capability, press the corresponding tape input selector to listen to just recorded signal. The settings of the tone controls and VOLUME control do not affect the recording.

## TO DUB AUDIO TAPES

1. Set the REC OUT selector to select the program source (DAT/TAPE 1 or TAPE 2) to be dubbed.
2. To listen to program source to be recorded, press the corresponding input selector.
3. Set the tape decks to play and record mode respectively.
4. To listen to other program source during dubbing, select the program source to be listened to with the input selector.

When your tape deck has three head monitoring capability, press the corresponding tape input selector to listen to just recorded signal. The settings of the tone controls and VOLUME control do not affect the dubbing.



## REMOTE CONTROL TRANSMITTER

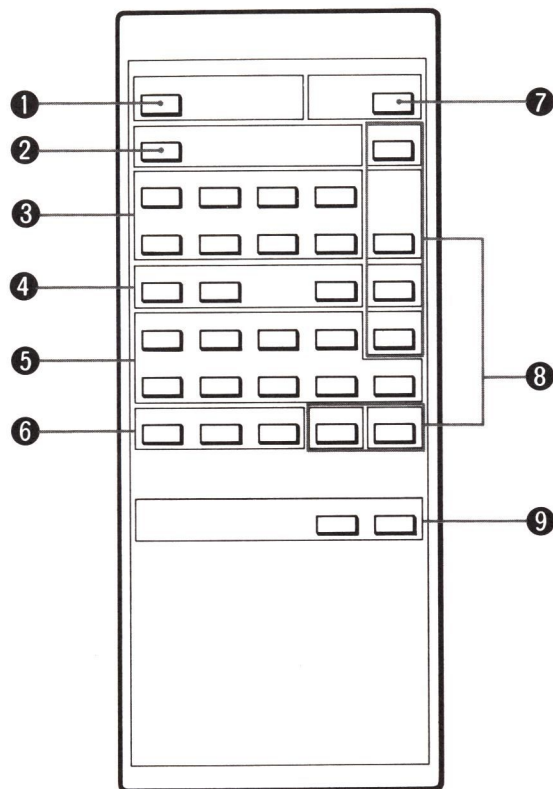

The remote control transmitter supplied with your receiver is designed to control all the most commonly used features of the receiver. If the CD player, turntable, cassette deck and graphic equalizer connected to your receiver are YAMAHA components designed for remote control compatibility (components with an mark), then this remote control transmitter will also control various functions of each component. Please consult your YAMAHA dealer for information on which components are compatible with the remote control transmitter. Note that any compatible YAMAHA CD player, or a compatible YAMAHA cassette deck which has a remote control sensor, can be directly operated by this remote control transmitter.

### 1 POWER key

Press this key to turn the power of receiver ON and OFF.

(Europe model only)

This key functions only when the STANDBY indicator is lit.

### 2 PLAY/CUT key

This key is used to start and stop record play on the turntable with mark connected to this unit. This key functions the same as the PLAY/CUT key on the turntable.

Pressing this key starts record play and pressing it again stops playing.

### 3 CD player section

The CD player with mark connected to this unit can be controlled directly with the remote control transmitter.



Press to advance to the beginning of the next tune.



Press to return to the beginning of the current tune.

When this key is pressed at the beginning of the tune, the play will start at the beginning of the previous tune.



Press to fast forward the tune.



Press to reverse the tune.

### DISC UP/DOWN

Applicable only to a compact-disc player that has the magazine-type automatic compact-disc changing mechanism; used for selection of the disc.

### PAUSE/STOP

Used to set the player to pause or stop mode. Pressing the key once to stop play temporarily and pressing it again stops play.

### PLAY

Press this key to start play.

### 4 Tuner section

These keys are used to select the broadcast station preset.

#### UP

Press to select the preset station. Each time this key is pressed, the preset number is increased by one. (Ex: P7→P8) When the key is pressed during the P8 (P16) station is received, the preset number will be changed to P1 (P9).

#### DOWN

Press to select the preset station. Each time this key is pressed, the preset number is decreased by one. (Ex: P8→P7) When the key is pressed during the P1 (P9) station is received, the preset number will be changed to P8 (P16).

#### P1-P8/P9-P16

Each time this key is pressed, the preset station range is changed between P1-P8 and P9-P16 alternately.

## 5 Tape deck section

These keys are used to operate the cassette deck with  mark connected to this unit.

### DECK A/B

Press to select the deck to be operated between the deck A and B on the double cassette deck.



Press to rewind the tape.

### PLAY

Press to start tape play. When the double cassette deck is used, pressing the key starts tape play on the last playing deck.



Press to fast forward the tape.

### REC/PAUSE

Press to set to recording pause mode.

### STOP

Press to stop the tape.

### REC MUTE

Press to make the non-recorded section during recording.

**DIR A** (for a double cassette deck only):

Press this key to change the tape running direction of DECK A.

**DIR B** (for a double cassette deck only):

Press this key to change the tape running direction of DECK B.

## 6 Equalizer section

These buttons can be used for operation of a YAMAHA graphic equalizer with the presetting function (such as the EQ-630, etc.).

### EQ ON/FLAT

Used to select whether or not to use the circuitry of an equalizer connected to the receiver.

### PRESET UP/DOWN

Select the desired preset channels with these keys.

## 7 SLEEP key

The power to the receiver is automatically switched OFF one hour after this key is pressed.

## 8 Input selector keys

Select the desired programs source with these keys.

## 9 VOLUME control keys

These keys are used to adjust the volume level heard from the speakers connected to this unit.

## BATTERY INSTALLATION

The remote control unit uses 2 batteries (size "AAA", R03). Install them according to the following illustration. Be sure that they are installed correctly.

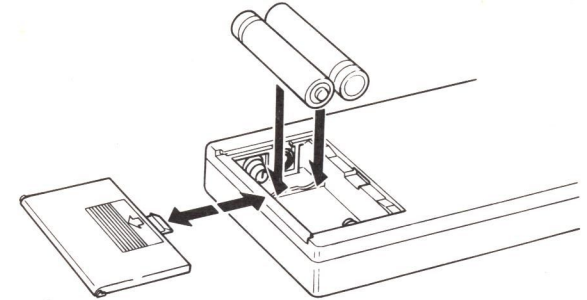

## OPERATION RANGE

You must point the remote control unit toward the receiver and be within about 7 meters (23 feet) of it for proper operation.

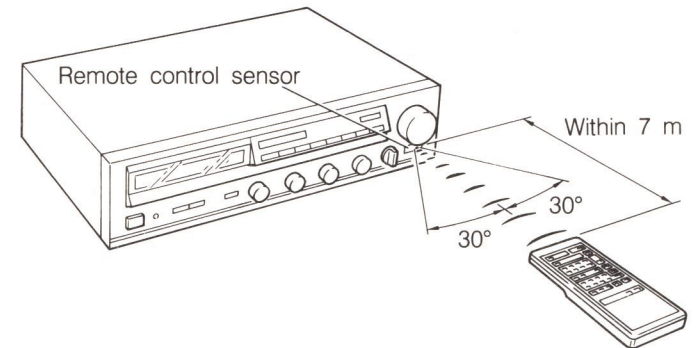



## SPECIFICATIONS

### AUDIO SECTION

Minimum RMS Output Power per Channel	
8 ohms, 20 Hz to 20 kHz, 0.02% THD	50 W
6 ohms, 20 Hz to 20 kHz, 0.04% THD	
[U.S.A. and Canada models]	55 W
[Australia, Europe, U.K. and General models]	53 W
Dynamic Power per Channel (IHF)	
8/6/4/2 ohms	
[U.S.A. and Canada models]	81/92/138/112 W
[Australia, Europe, U.K. and General models]	80/92/110/100 W
DIN Standard Output Power per Channel	
4 ohms, 1 kHz, 1% THD	
[Europe model only]	65 W
IEC Power (1 kHz, 0.04% THD 8/6 ohms)	
[Europe model only]	57/67 W
Power Band Width	
8 ohms, 25 W, 0.1% THD	10 Hz to 50 kHz
Damping Factor	
8 ohms, 1 kHz	50 or more
Input Sensitivity/Impedance	
PHONO	2.5 mV/47 k-ohms
CD/TAPE/VIDEO/AUX	150 mV/50 k-ohms
Input Sensitivity (New IHF)	
[U.S.A. and Canada models]	
PHONO	0.42 mV
CD/TAPE/VIDEO/AUX	25 mV
Maximum Input Signal Level (1 kHz, 0.01% THD)	
PHONO	110 mV
Output Level/Impedance	
REC OUT	150 mV/1 k-ohms
Headphone Jack Rated Output/Impedance	
8 ohms, 0.015% THD	0.7 V/ 220 ohms
Frequency Response (20 Hz to 20 kHz)	
CD/TAPE/VIDEO/AUX	±0.5 dB
RIAA Equalization Deviation	
PHONO	±0.5 dB
Total Harmonic Distortion (20 Hz to 20 kHz)	
PHONO to REC OUT (3 V)	0.01%
CD/TAPE/VIDEO/AUX to SP OUT (25 W/8 ohms)	0.012%
Intermodulation Distortion	
CD/TAPE/VIDEO/AUX (Rated Output/8 ohms)	0.012%
Signal-to-Noise Ratio (IHF-A Network)	
PHONO (5 mV Input Shorted)	
[Except Europe model]	88 dB
[Europe model]	83 dB
CD/TAPE/VIDEO/AUX (Shorted)	103 dB
Signal-to-Noise Ratio (New IHF)	
[U.S.A. and Canada models]	
PHONO	74 dB
CD/TAPE/VIDEO/AUX	85 dB
Residual Noise (IHF-A Network)	140 µV

Channel Separation (1 kHz, Vol. -30 dB)	
PHONO (Input Shorted)	55 dB
CD/TAPE/VIDEO/AUX	
(Input 5.1 k-ohms Terminated)	52 dB
Tone Control Characteristics	
BASS : Boost/cut	±10 dB (50 Hz)
Turnover Frequency	350 Hz
TREBLE : Boost/cut	±10 dB (20 kHz)
Turnover Frequency	3.5 kHz
Filter Characteristics	
Bass Extension	60 Hz, 8 dB/oct
Continuous Loudness Control	-40 dB (1 kHz)
	(Level related equalization)

### FM SECTION

Tuning Range	
[U.S.A., Canada and General models]	87.5 to 107.9 MHz
[Australia, Europe, U.K. and General models]	87.5 to 108.0 MHz
50 dB Quieting Sensitivity (IHF, 75 ohms)	
[Except Europe model]	
Mono	1.55 µV (15.1 dBf)
Stereo	21 µV (37.7 dBf)
Usable Sensitivity (75 ohms)	
(30 dB S/N Quieting, 1 kHz, 100% mod.)	
[Except Europe model]	0.8 µV (9.3 dBf)
DIN, Mono (S/N 26 dB) [Europe model]	1.4 µV
DIN, Stereo (S/N 46 dB) [Europe model]	30 µV
Image Response Ratio	
[Except Europe model]	45 dB
[Europe model]	80 dB
IF Response Ratio	80 dB
Spurious Response Ratio	70 dB
AM Suppression Ratio	55 dB
Capture Ratio	1.5 dB
Alternate Channel Selectivity	
[Except Europe model]	85 dB
Selectivity (two signals, 40 kHz Dev.)	
[Europe model]	50 dB
Signal-to-Noise Ratio	
(IHF) Mono/Stereo	
[Except Europe model]	81/76 dB
(DIN-weighted, 40 kHz Dev.) Mono/Stereo	
[Europe model]	75/70 dB
Harmonic Distortion (1 kHz)	
Mono/Stereo	
[Except Europe model]	0.1/0.1%
Mono/Stereo	
[Europe model (40 kHz Dev.)]	0.1/0.1%
Frequency Response	
30 Hz to 15 kHz	0 ±0.5 dB

Stereo Separation (1 kHz)	
[Except Europe model]	50 dB
[Europe model (40 kHz Dev.)]	50 dB

### AM SECTION

Tuning Range	
[U.S.A., Canada and General models]	530 to 1,610 kHz
[Australia, Europe, U.K. and General models]	
	531 to 1,611 kHz
Usable Sensitivity	250 µV/m
Selectivity	32 dB
Signal-to-Noise Ratio	50 dB
Image Response Ratio	40 dB
Spurious Response Ratio	50 dB
Harmonic Distortion (400 Hz)	0.3%

### AUDIO SECTION

Output Level/Impedance	
FM (100 % mod., 1 kHz)	
[Except Europe model]	150 mV/3.8 k-ohms
[Europe model (40 kHz Dev.)]	400 mV/3.8 k-ohms
AM (30% mod., 1 kHz)	
[Except Europe model]	150 mV/3.8 k-ohms
[Europe model (40 kHz Dev.)]	150 mV/3.8 k-ohms

### GENERAL

Power Supply	
[U.S.A. and Canada models]	AC 120 V, 60 Hz
[Australia and U.K. models]	AC 240 V, 50 Hz
[Europe model]	AC 220 V, 50 Hz
[General model]	AC 110-120/220-240 V, 60/50 Hz
Power Consumption	
[U.S.A. and General models]	280 W
[Canada model]	280 W, 320 VA
[Australia, Europe and U.K. models]	350 W
AC Outlets	
[U.S.A., Canada and General models]	
Switched	100 W max.
Unswitched	200 W max.
[Australia, Europe and U.K. models]	
Switched	100 W max.
Dimensions (W x H x D)	435 x 126 x 289 mm
	(17-1/8" x 4-15/16" x 11-3/8")
Weight	5.6 kg (12 lbs. 5 oz.)
Accessories	AM loop antenna x 1
	Indoor FM antenna x 1
	Remote control cable (mini-plug) x 1
	Remote control cable (6-pin) x 1
	Remote control transmitter x 1
	Battery x 2

Specifications subject to change without notice.

## TROUBLESHOOTING

If the unit fails to operate normally, check the following points to determine whether the fault can be corrected by the simple measures suggested. If it cannot be corrected, or if the fault is not listed in the SYMPTOM column, disconnect the power cord and contact your dealer or service center for help.

	SYMPTOM	CAUSE	REMEDY
Amplifier	The receiver fails to turn on when the POWER switch is pressed.	Power cord is not plugged in or is not completely inserted.	Firmly plug in the power cord.
	No sound.	Incorrect output cord connections.	Connect cord properly. If the problem persists, the cables may be defective.
		Incorrect receiver operation.	Set the receiver controls to the correct input selection.
	Sound "hums".	Incorrect cord connections.	Firmly connect the audio plugs. If the problem persists, the cord may be defective.
FM	FM stereo reception is noisy.	Because of the characteristics of FM stereo broadcasts, this is limited to cases where the transmitter is far away or the antenna input is poor.	Check the antenna connections. Try using a multiple element FM antenna.
	There is distortion and clear reception cannot be obtained even with a good FM antenna.	There is multipath interference.	Adjust antenna placement to eliminate multipath interference.
	A desired station cannot be tuned in with Auto tuning.	The station is too weak.	Use Manual tuning mode. Use high quality directional FM antenna.
AM	A desired station cannot be tuned in with Auto tuning.	Weak signal or loose antenna connections.	Tighten the AM loop antenna connections and rotate it for best reception.
			Use Manual tuning mode.
	There are continuous crackling and hissing noises.	These noise result from lightning, fluorescent lamps, motors, thermostats and other electrical equipment.	Use an outdoor antenna and a ground wire. This will help some what but it is difficult to eliminate all noise.
	There are buzzing and whining noises (especially in the evening).	A television set is being used nearby.	Move the television away.

**YAMAHA ELECTRONICS CORPORATION, USA** 6660 ORANGETHORPE AVE. BUENA PARK, CALIF. 90620, U.S.A.  
**YAMAHA CANADA MUSIC LTD.** 135 MILNER AVE., SCARBOROUGH, ONTARIO M1S 3R1, CANADA  
**YAMAHA ELECTRONIK EUROPA G.m.b.H.** 2084 RELLINGEN, BEI HAMBURG, SIEMENSSTR. 22/34, F.R. OF GERMANY  
**YAMAHA ELECTRONIQUE FRANCE S.A.** 17 RUE DES CAMPANULES, LOGNES 77321 MARNE LA VALLEE CEDEX 2, FRANCE  
**YAMAHA ELECTRONICS (UK) LTD.** YAMAHA HOUSE, 200 RICKMANSWORTH ROAD WATFORD, HERTS WD1 7JS, ENGLAND  
**YAMAHA SCANDINAVIA A.B.** J A WETTERGRENS GATA 1, BOX 30053, 400 43 VASTRA FROLUNDA, SWEDEN  
**YAMAHA MUSIC AUSTRALIA PTY, LTD.** 17-33 MARKET ST., SOUTH MELBOURNE, 3205 VIC., AUSTRALIA

If You Didn't Get This From My Site,  
 Then It Was Stolen From...  
[www.SteamPoweredRadio.Com](http://www.SteamPoweredRadio.Com)

# YAMAHA

**YAMAHA CORPORATION**  
 10-1 NAKAZAWA-CHO, HAMAMATSU, JAPAN

VG49350-I BWgW,b Printed in Japan