

OPERATING INSTRUCTIONS

model 1122

STEREO TRANSCRIPTION PREAMPLIFIER



If You Didn't Get This From My Site,
Then It Was Stolen From...
www.SteamPoweredRadio.Com

Universal Audio

products of



UNITED RECORDING ELECTRONICS INDUSTRIES

8460 SAN FERNANDO RD., SUN VALLEY, CALIFORNIA 91352
TELEX 65-1389 UREI SNVY

(213) 767-1000

a UREI company

BEFORE PROCEEDING WITH COMPLETE UNPACKING AND SETUP,
CONSULT UNPACKING AND INSPECTION INSTRUCTIONS ON PAGE 4

model 1122

STEREO TRANSCRIPTION PREAMPLIFIER



If You Didn't Get This From My Site,
Then It Was Stolen From...
www.SteamPoweredRadio.Com



United Recording Electronics Industries

8460 SAN FERNANDO ROAD, SUN VALLEY, CALIFORNIA 91352

(213) 767-1000

Printed in U.S.A.

© Copyright 1978, UREI

TABLE OF CONTENTS

	PAGE
<u>SECTION I. INTRODUCTION</u>	
1.1 DESCRIPTION	1
1.2 TECHNICAL SPECIFICATIONS	2
1.3 CONTROLS	3
1.4 CONNECTIONS	3
<u>SECTION II. INSPECTION AND INSTALLATION</u>	
2.1 UNPACKING AND INSPECTION	4
2.2 ENVIRONMENTAL CONSIDERATIONS	4
2.3 POWERING	4
2.4 EXTERNAL CONNECTIONS	5
<u>SECTION III. OPERATING INSTRUCTIONS</u>	
3.1 GENERAL	7
3.2 FREQUENCY RESPONSE CHARACTERISTICS	7
<u>SECTION IV. MAINTENANCE</u>	
4.1 GENERAL	8
4.2 REPAIRS AND WARRANTY	8
<u>SECTION V. APPENDIX</u>	
FIGURE 5. PLOTTED GRAPH	
FIGURE 6. SCHEMATIC DIAGRAM OF UREI MODEL 1122	

SECTION I
INTRODUCTION



Figure 1. Model 1122 Front Panel

1.1 DESCRIPTION

The 1122 is a two-channel, solid-state, equalized preamplifier/line amplifier designed to provide the highest quality disc reproduction for broadcast and recording applications. While primarily intended for stereo use, it may be utilized very effectively for two separate monophonic channels.

Any magnetic pickup designed for operation with a 47,000 ohm termination may be used with the Model 1122, and its wide dynamic range provides faithful reproduction from low level classical recordings or maximum excursion single records. Outputs are balanced for 600-ohm or 150-ohm lines (approximately 80 ohms actual). Installation is simple, and with standard grounding practices the 1122 is exceptionally immune to rf interference.

High frequency and low frequency trimmers are provided for each channel, to allow balancing the response of a stereo cartridge or of two monophonic cartridges.

1.2 TECHNICAL SPECIFICATIONS

ELECTRICAL

FREQUENCY RESPONSE: RIAA/NAB disc playback characteristic within ± 1 dB from 30 Hz to 15 kHz; (NAB 1964 Disc Standard, recommended low frequency roll-off 6 dB/octave, 3 dB down at 20 Hz).

INPUT IMPEDANCE: 47,000 ohms.

GAIN: 54 dB, continuously variable.

DISTORTION: Less than 0.5% THD at +20 dBm, from 30 Hz to 20 kHz.

HUM AND NOISE: At least 60 dB below +6 dBm output, (gain set for +6 dBm output, with 5 mV input, 32 Hz to 18 kHz band-pass filter).

OUTPUT: Floating, transformer isolated.

OUTPUT IMPEDANCE: For 600 or 150 ohm balanced line (approximately 80 ohm actual).

CHANNEL SEPARATION: 50 dB minimum at 10 kHz,
50 dB minimum at 1 kHz,
42 dB minimum at 100 Hz.

ENVIRONMENT: Operating within 0.5 dB of all specifications from -5°C to $+55^{\circ}\text{C}$ (23°F to 131°F).

POWER REQUIREMENTS: 100 - 125 VAC or
200 - 250 VAC, strappable,
50/60 Hz, less than 10 W.

PHYSICAL

DIMENSIONS: 195 x 95.3 mm rack panel; depth behind panel 232 mm; (7-11/16 x 3-3/4 x 9-1/8").

FINISH: Panel is 3.18 mm (1/8") brushed black anodized aluminum. Chassis is cadmium plated steel.

WEIGHT: 2.67 kg (5 lb., 14 oz.).

SHIPPING WEIGHT: 3.18 kg (7 lb.).

1.3 CONTROLS

CHANNEL LEVEL: Located on the front panel and marked "A Level" and "B Level". Used to adjust the overall operating level and to balance the individual levels of the two channels.

RESPONSE TRIMMERS: Located inside the unit on the PC-board. Used to balance the response of the two channels of a stereo cartridge, or of two monophonic cartridges. High and low frequency response trimmers are provided for each channel.

1.4 CONNECTIONS

INPUT: RCA-type jacks on the rear panel.

OUTPUT: Barrier strip terminal on the rear panel. (See installation instructions, Section II, Figures 2 & 3.)

SECTION II

INSPECTION AND INSTALLATION

2.1 UNPACKING AND INSPECTION

The Model 1122 was carefully packed at the factory, and the container was designed to protect the unit from rough handling. Nevertheless, we recommend careful examination of the shipping carton and its contents for any sign of physical damage which could have occurred in transit.

If damage is evident, do not destroy any of the packing material or the carton, and immediately notify the carrier of a possible claim for damage. Shipping claims must be made by the consignee.

The shipment should include:

Model 1122 Stereo Transcription Preamplifier

UREI Instruction Manual

Two-part Warranty Card bearing the same serial number as the Model 1122.

2.2 ENVIRONMENTAL CONSIDERATIONS

The system will operate satisfactorily over a range of ambient temperatures from -5°C to $+55^{\circ}\text{C}$ ($+23^{\circ}\text{F}$ to 131°F), and up to 80% relative humidity.

If the system is installed in an equipment rack together with high heat producing equipment (such as power amplifiers), adequate ventilation should be provided to prolong the life of components. Also, while circuitry susceptible to hum pick-up is sufficiently shielded from moderate electromagnetic fields, installation should be planned to avoid mounting the system immediately adjacent to large power transformers, motors, etc.

2.3 POWERING

Unless a tag on the line cord specifies otherwise, the Model 1122 was shipped ready for operation with nominal 115 VAC power mains. In order to change this for nominal 230 VAC, (50 or 60 Hz), the strapping on the power transformer must be changed. Remove the jumpers between terminals 1 and 3, and also between terminals 2 and 4. Instead, add a jumper from terminal 2 to 3. Be sure to change the fuse to the correct value: 1/8 A slo-blo when changing to 230 V operation, or 1/4 A slo-blo for 115 V operation.

2.4 EXTERNAL CONNECTIONS

2.4.1 INPUT CONNECTIONS

Input connections are made to the 1122 through two "RCA" type standard phono jacks on the rear chassis, marked "A" and "B". Most phono pickup arms are equipped with shielded cables terminating in plugs which will directly mate with the 1122 jacks. The Model 1122 must be physically located to allow direct connection via these short cables, as any attempt to extend them with additional cable or extension cables will result in loss of high frequencies due to the added shunt capacitance.

2.4.2 OUTPUT CONNECTIONS

Permanent output signal wires should be shielded cable, and connected in accordance with standard wiring practice, as indicated on the rear panel barrier strip.

If the Model 1122 output is connected to a high impedance circuit, we recommended shunting the "+" and "COM" output terminals with 620 ohm, 1/2 watt resistors. This assures optimum loading for the Model 1122.

(Illustrations on next page)

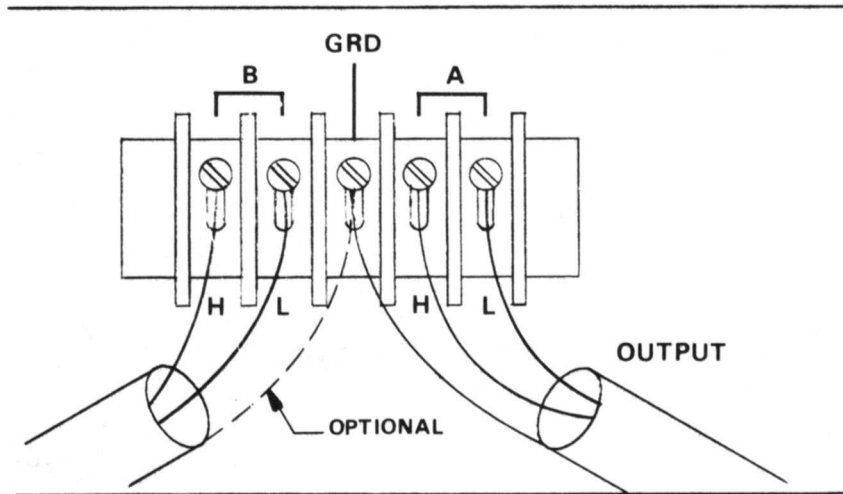

Figure 2. Connecting The Model 1122 With Balanced Output Circuits.

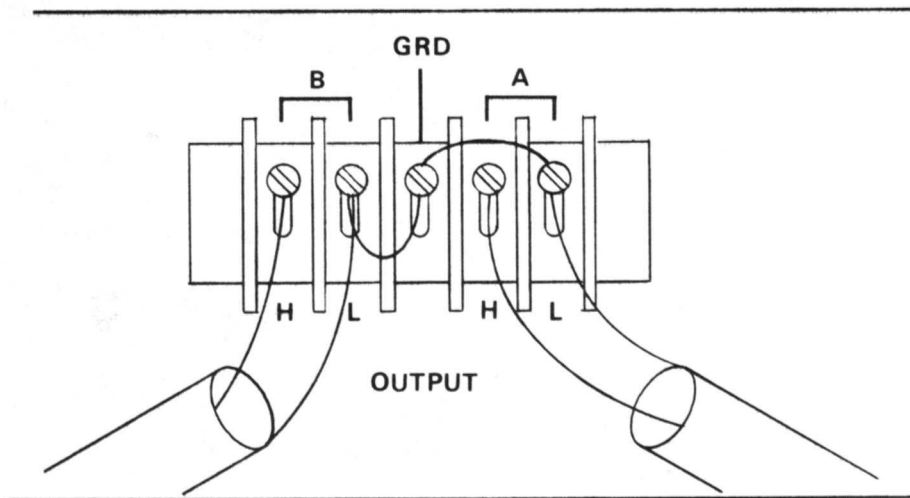

Figure 3. Connecting The Model 1122 With Unbalanced Output Circuits.

SECTION III
OPERATING INSTRUCTIONS

3.1 GENERAL

After the Preamplifier has been installed and is connected to both the signal source and the succeeding equipment according to Section II, power may be turned ON.

The output level may be adjusted individually for each channel by the recessed, screwdriver operated controls on the front panel.

3.2 FREQUENCY RESPONSE CHARACTERISTICS

Initially, the frequency response was adjusted at the factory to conform with standard RIAA/NAB characteristics. Both low and high frequency response may be changed within an envelope shown in the graph, Figure 5 (Appendix). The frequency adjustments are located on the printed circuit board and are accessible after the cover has been removed from the Model 1122. (See Figure 4.)

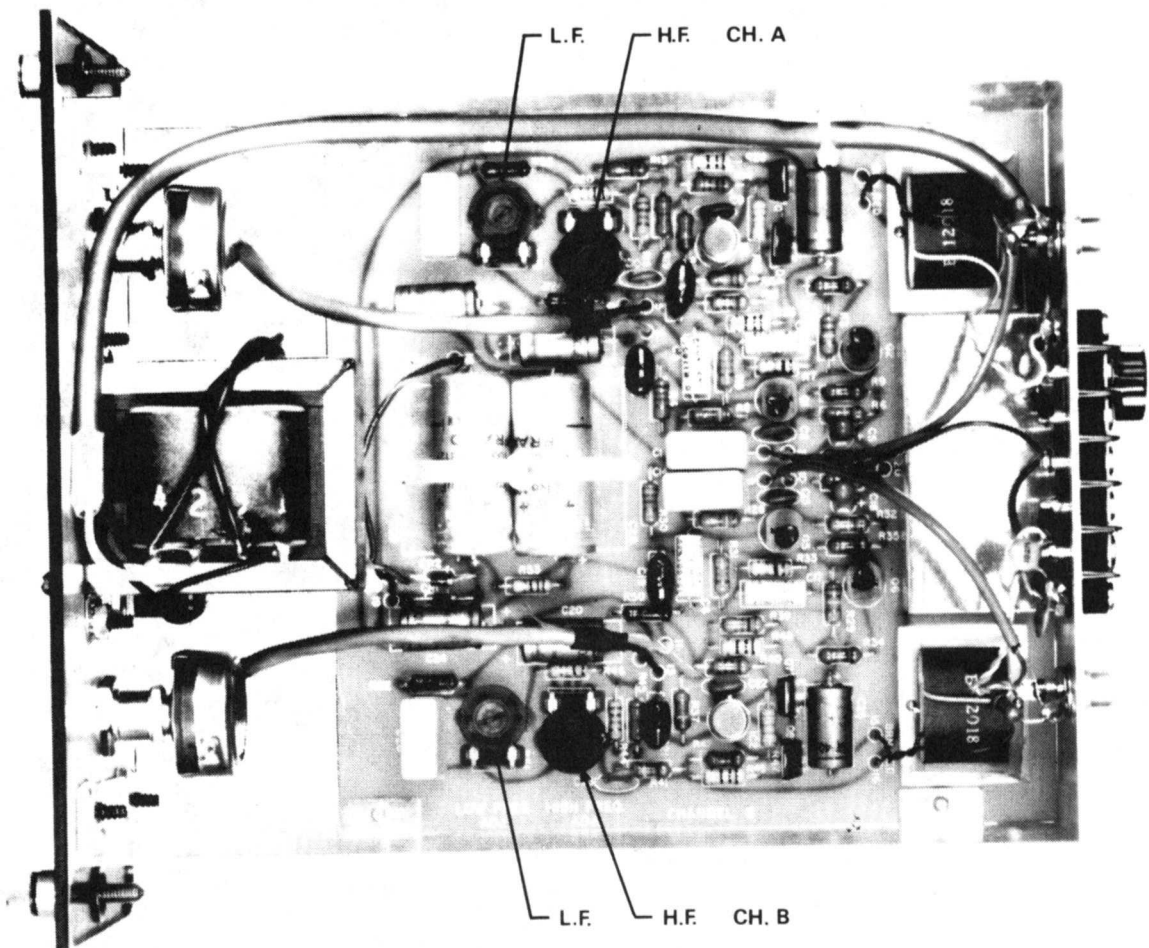

Figure 4. Response Trimmers (Top View).

SECTION IV

MAINTENANCE

4.1 GENERAL

The Model 1122 is an all solid-state unit, ruggedly constructed with only the highest quality components. As such, it should provide years of trouble free use with normal care. All parts used are conservatively rated for their application, and workmanship meets the rigid standards you have learned to expect in UREI products.

NO SPECIAL PREVENTIVE MAINTENANCE IS REQUIRED.

4.2 REPAIRS AND WARRANTY

The Model 1122 is factory warranted to the original purchaser against defects in material and workmanship for one year after initial purchase. This limited warranty must be activated at the time of purchase by returning the registry portion of the Warranty Card to the factory. Should a malfunction ever occur, the dealer from whom the unit was purchased will be glad to handle return for factory repair; alternately, for prompt service, ship the unit prepaid directly to the factory. Be sure it is well packed in a sturdy carton, with shock-absorbing material such as foam rubber, styrofoam pellets or "bubble-pack" completely filling the remaining space. Particular attention should be paid to protecting the protruding parts. Include a note describing the malfunction, and instructions for return. We will pay one-way return shipping costs on any in-warranty repair.

Because of specially selected components in this product, field repairs are not authorized during the warranty period, and attempts to perform repairs may invalidate the warranty.

SECTION V

APPENDIX

46 6882

Urei

200 G

KEUDIO FREQUENCY
KEUFFEL & ESSER CO. WIFE N. J.

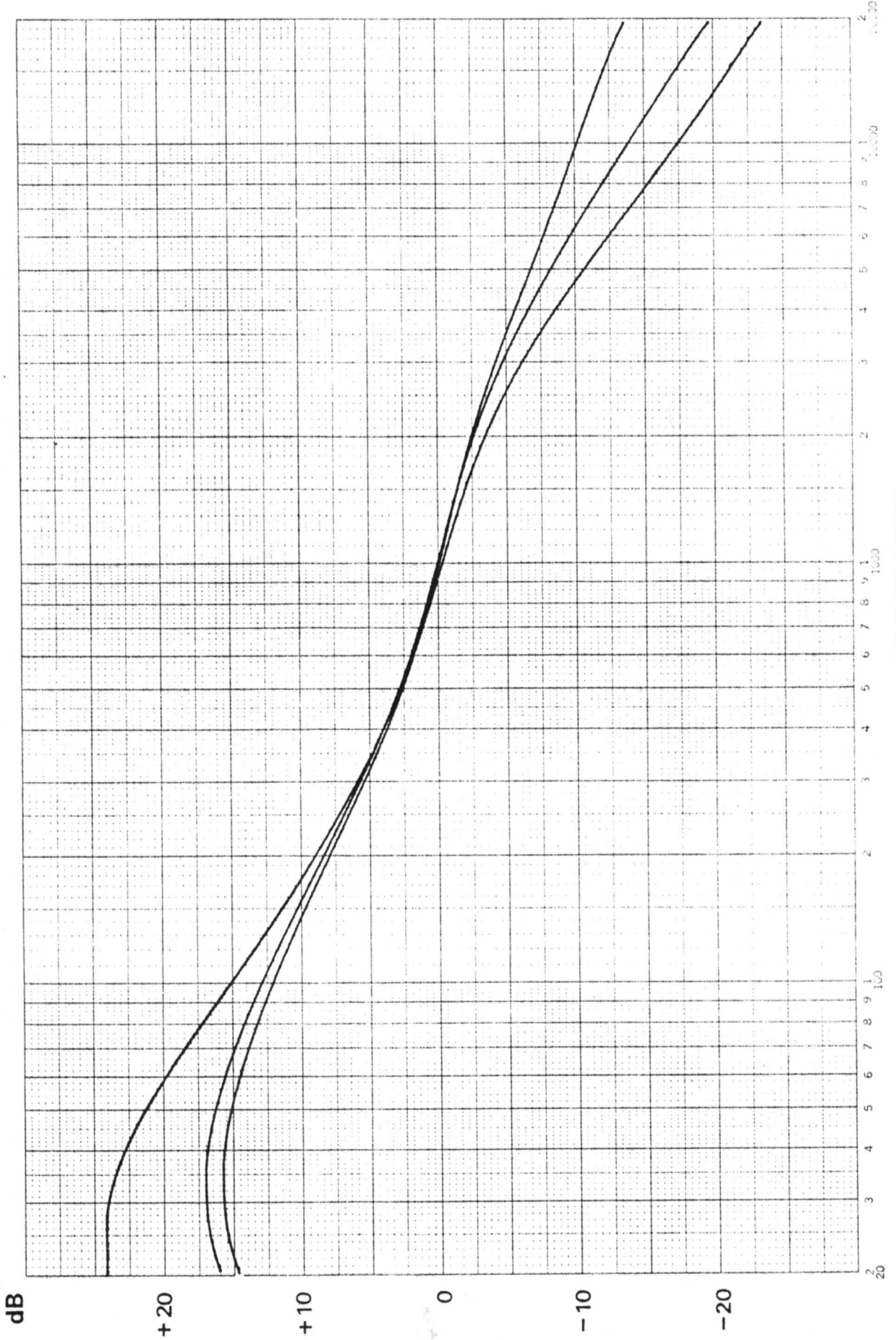

FREQUENCY IN CYCLES PER SECOND
TYPICAL EFFECT OF RESPONSE TRIMMERS

VERTICAL SENSITIVITY : 10 dB/inch
HORIZONTAL SWEEP : 60 seconds

UNITED RECORDING ELECTRONICS INDUSTRIES

REMARKS : 1122

DATE : 12-77

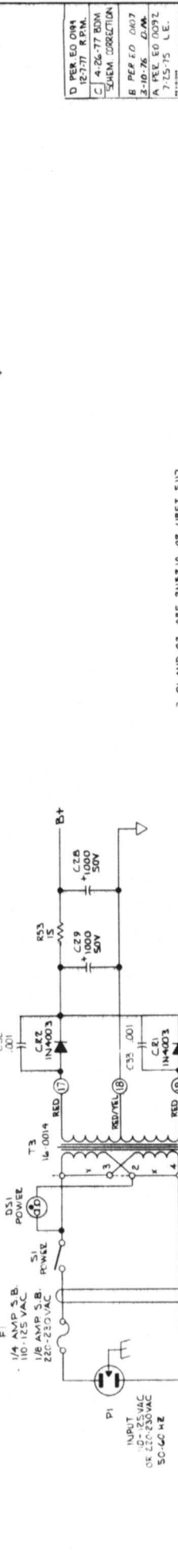
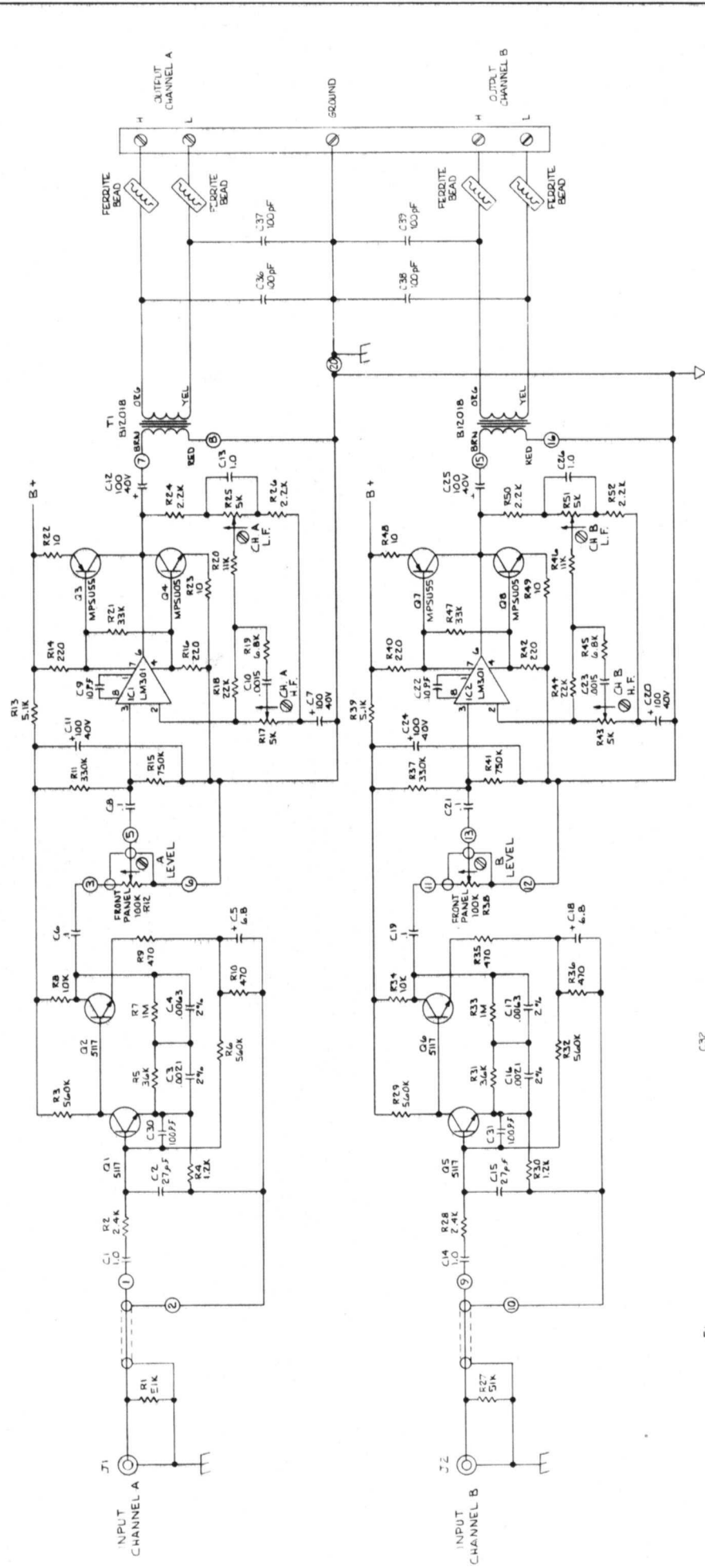

D PER EO 0194
 12-77 R.R.M.
 C 4-26-77 BDM
 SUREM CORRECTION
 B PER EO 0107
 3-10-76 J.W.M.
 A PER EO 0092
 1-15-75 L.E.

UNITED INDUSTRIES
 LOS ANGELES CALIFORNIA
 1122
 6-5-75
 L.E. D12077

SCHEMATIC
 PRE-AMPLIFIER

3. DI. AUD. OL. ARE 250V.10. OR USE BT 5117
 2. RESISTOR VALUES ARE IN OHMS = 5%, 1/2W
 1. CAPACITOR VALUES ARE IN MICROFARADS
 NOTE:

1/4 AMP S.B.
 110-125 VAC
 1/8 AMP S.B.
 220-230 VAC
 P1
 INPUT
 50-60 HZ
 OR 230-250VAC
 50-60 HZ

NPWR STRAPPED FOR 110V MAINS
 FOR 220V, 1. CUT STRIPS X
 2. ADD STRIP INDICATED
 BY DOTTED LINE
 3. CHANGE FUSE TO 1/8 AMP S.B.