

STEREO MONITOR

MODEL 724A

# 262-3



**TFT**

**TIME AND FREQUENCY  
TECHNOLOGY, INC.**

Serial No. \_\_\_\_\_

Rev. Level **B** \_\_\_\_\_

STEREO MONITOR

MODEL 724A

# 262-3



Time & Frequency Technology, Inc.  
3000 Olcott Street  
Santa Clara, CA 95051

(408) 246-6365

If You Didn't Get This From My Site,  
Then It Was Stolen From...

[www.SteamPoweredRadio.Com](http://www.SteamPoweredRadio.Com)

## TABLE OF CONTENTS

		Page
SECTION 1	GENERAL INFORMATION	
	1.1 General Description.....	1-1
	1.2 Specifications.....	1-1
	1.3 Accessory Equipment.....	1-3
	1.4 Warranty.....	1-3
	1.5 Claim for Damage in Shipment.....	1-3
SECTION 2	INSTALLATION	
	2.1 Unpacking and Inspection.....	2-1
	2.2 Power Requirements.....	2-1
	2.3 Installation Procedures.....	2-1
	2.4 Model 704C Remote Panel Meter Connection.....	2-1
SECTION 3	OPERATION	
	3.1 General.....	3-1
	3.2 Control, Connections and Indicator.....	3-1
	3.2.1 Front Panel.....	3-1
	3.2.2 Rear Panel.....	3-5
	3.3 Turn On and Warm Up.....	3-6
	3.4 Calibration Procedures.....	3-6
	3.4.1 Meter Calibration Using Model 763.....	3-6
	3.4.2 Meter Calibration with a Composite Input.....	3-7
	3.4.3 Phase Calibration.....	3-7
	3.5 Use of the Model 724A for Monitoring...	3-7
	3.6 Use of the Model 724A for Measurement..	3-8
	3.6.1 Main-Channel (L+R) Modulation.....	3-8
	3.6.2 Stereo Subchannel (L-R) Modulation.....	3-8
	3.6.3 Pilot Carrier Modulation.....	3-8
	3.6.4 38 kHz Subcarrier Suppression.....	3-8
	3.6.5 Stereo Channel Separation (Left Channel Modulated).....	3-9
	3.6.6 Stereo Channel Separation (Right Channel Modulated).....	3-9
	3.6.7 Main Channel to Subchannel Crosstalk...	3-9
	3.6.8 Subchannel to Main Channel Crosstalk...	3-10
	3.6.9 FM Noise.....	3-10
	3.6.10 Distortion.....	3-11
	3.6.11 Pilot Frequency.....	3-11
	3.7 Use of the Model 704C Remote Meter Panel.....	3-11

## TABLE OF CONTENTS (Continued)

		Page
SECTION 4	THEORY OF OPERATION	
4.1	General Block Diagram Discussion..	4-1
4.1.1	Modulation Monitoring Circuits....	4-1
4.1.2	Measurement Circuits.....	4-2
4.2	Meter Amplifier & Attenuator Board (A-3).....	4-2
4.2.1	Attenuator.....	4-3
4.2.2	Modulation/Test Meter Amplifier...	4-3
4.2.3	Left-Channel Meter Amplifier.....	4-3
4.2.4	Audio Amplifiers.....	4-3
4.3	Demodulator & Filter Board (A-2)..	4-4
4.3.1	Buffer Amplifiers & Function Switches.....	4-4
4.3.2	19-kHz Filter.....	4-4
4.3.3	38-kHz Filter.....	4-5
4.3.4	L+R Channel Filter (FL1).....	4-5
4.3.5	L-R Channel Filter (FL2).....	4-5
4.3.6	38-kHz Phase-Locked Loop.....	4-5
4.3.7	Stereo Demodulator.....	4-6
4.3.8	Left-Channel Filter (FL3) and Right Channel (FL4).....	4-6
4.3.9	Phase Calibration.....	4-6
4.4	Power Supply Board (A1).....	4-7
SECTION 5	MAINTENANCE	
5.1	General.....	5-1
5.2	Periodic Maintenance.....	5-1
5.3	Performance Checks.....	5-1
5.3.1	Calibration Accuracy Check.....	5-1
5.3.2	Amplitude Response Check.....	5-2
5.3.3	Stereo Pilot Indicator.....	5-3
5.3.4	Output Check.....	5-3
5.3.5	Stereo Separation Check.....	5-4
5.3.6	Crosstalk and Distortion Check....	5-5
SECTION 6	SCHEMATIC DIAGRAMS	
6.1	Block Diagram.....	
6.2	Wiring Diagram - Main Chassis Front & Rear.....	
6.3	Audio Meter Amplifier (A3).....	
6.4	Demodulator/Filter Board (A2).....	
6.5	Power Supply (A1).....	

SECTION 1  
GENERAL INFORMATION

1.1 General Description.

The Model 724A Stereo Monitor is intended for use with the TFT Model 763 FM Frequency and Modulation Monitor to meet all FM stereo monitoring requirements and to provide proof-of-performance measurements.

Two separate meters allow monitoring of right and left channels simultaneously. The meters can also be used to measure separation between right and left channels, crosstalk between main and sub channels, 38 kHz carrier suppression, 19 kHz injection level, and FM signal-to-noise ratio. The various meter functions are selected by front-panel pushbutton switches. Power for the Model 724A is supplied by the Model 763.

The Model 724A Stereo Monitor, when used with the Model 763 FM Frequency and Modulation Monitor, meets the requirements of Section 73.332, Sub-sections d and e, of the FCC regulations relating to FM stereo monitors.

1.2 Specifications.

Composite input

Level..... 500 mV RMS  
Impedance..... 600 ohms unbalanced

Pilot Measurements

Level accuracy.....  $\pm 0.5\%$  from 6% to 12% modulation

The 19 kHz pilot frequency is returned to the digital counter in the Model 764. Accuracy and resolution are  $\pm 0.1$  Hz.

Modulation Meters

Frequency response measurements:

Left channel, right channel,  
and L+R channel.....  $\pm 4\%$ , 50 Hz to 15 kHz  
L-R channel.....  $\pm 4\%$ , 23 kHz to 53 kHz

Separation measurements:

Left to right and right to  
left..... 45 dB min., 50  
Hz to 15 kHz

Crosstalk measurements:

(L+R) to (L-R)..... 60 dB min.  
(L-R) to (L+R)..... 60 dB min.  
SCA to (L-R)..... 66 dB min.  
SCA to (L+R)..... 66 dB min.

Outputs

Left and right channel monitoring:

Impedance..... 600 ohms unbalanced  
Level..... 1 V RMS at 100%  
modulation, 400  
Hz

Frequency response  
(without de-emphasis)..... +4%, 50 Hz to  
15 kHz

Distortion..... 0.5% max.

Noise level (with  
de-emphasis)..... 60 dB min. below  
100%

Remote meter..... Outputs for Model  
704C remote meter  
panel (both meters).

Pilot frequency (19 kHz):

Level..... 100 mV RMS

Composite Output

Impedance..... 10k ohms  
Level..... 1 V RMS (100%)

Power Requirements

Requires 25.2 VAC, center tapped from Model 763.

Physical and Environmental Specifications

Operating temperature..... 0° to 50° C

Dimensions..... 19" W x 7" H x  
16" D  
Weight..... 15 pounds  
Cabinet..... Rack mounting

1.3 Accessory Equipment.

The TFT Model 704C Remote Readout Panel duplicates the readings of the two Model 724A front-panel meters.

1.4 Warranty.

TIME & FREQUENCY TECHNOLOGY, INC., warrants each of the instruments of its manufacture to be produced to meet the specifications delivered to the BUYER; and to be free from defects in material and workmanship and will repair or replace, at its expense, for a period of one year from the date of delivery of equipment, any parts which are defective from faulty material or poor workmanship.

Instruments found to be defective during the warranty period shall be returned to the factory with transportation charges prepaid by BUYER. It is with respect to any nonconforming equipment and parts thereof and shall be in lieu of any other remedy available by applicable law. All returns to the factory must be authorized by the SELLER, prior to such returns. Upon examination by the factory, if the instrument is found to be defective, the unit will be repaired and returned to the BUYER, with transportation charges prepaid by SELLER.

Transportation charges for instruments found to be defective within the first thirty (30) days of the warranty period will be paid both ways by the SELLER.

Transportation charges for warranty returns, wherein failure is found not to be the fault of the SELLER, shall be paid both ways by the BUYER.

NO OTHER WARRANTY IS EXPRESSED OR IMPLIED. TFT IS NOT LIABLE FOR CONSEQUENTIAL DAMAGES.

1.5 Claim for Damage in Shipment.

Your instrument should be inspected and tested as soon as it is received. The instrument is insured for safe delivery. If the instrument is damaged in any way or fails to operate properly, file a claim with the carrier, or if insured separately, with the insurance company.

WE SINCERELY PLEDGE OUR IMMEDIATE AND FULLEST COOPERATION TO ALL USERS OF OUR PRECISION ELECTRONICS INSTRUMENTS.

PLEASE ADVISE US IF WE CAN ASSIST YOU IN ANY MANNER

Time & Frequency Technology, Inc.  
3000 Olcott Street  
Santa Clara, CA 95051  
408-246-6365



SECTION 2  
INSTALLATION

2.1            Unpacking and Inspection.

Upon receiving the instrument, inspect the packing box and instrument for signs of possible shipping damage. Operate the instrument in accordance with the procedures of Section 3 of this manual. If the instrument is damaged or fails to operate properly, file a claim with the transportation company, or with the insurance company if insured separately.

2.2            Power Requirements.

Power for the Model 724A (25.2 VAC) is supplied by the Model 763 FM Modulation Monitor. Refer to Paragraph 2.3 below for connections.

2.3            Installation Procedures.

- a. Mount the Model 724A in the equipment rack.
- b. Connect the furnished three-wire power cable between J10 on the Model 724A and J2 on the Model 763. A ground cable between the two instruments is also required. Refer to Figure 2-1 for connection.
- c. Connect the furnished coaxial cable between COMPOSITE INPUT connector J7 on the rear panel of the Model 724A and J5 (TO STEREO MONITOR) output on the Model 763.
- d. If the studio stereo generator is to be monitored, connect its composite output to COMPOSITE INPUT connector J7 on Model 724A.
- e. Connect another furnished coaxial cable from STEREO PILOT (19 kHz) connector J3 on the Model 724A to PILOT CARR connector on the rear panel of the Model 763.

NOTE

For information on installing and making connections to the Model 763, refer to the Model 763 instruction manual.

2.4            Model 704C Remote Panel Meter Connection.

Connect the 50 foot, three wire cable furnished with the Model 704C to terminals A, B, and C of J10 on the Model 724A rear panel. Wraparound labels identify the cable wires.

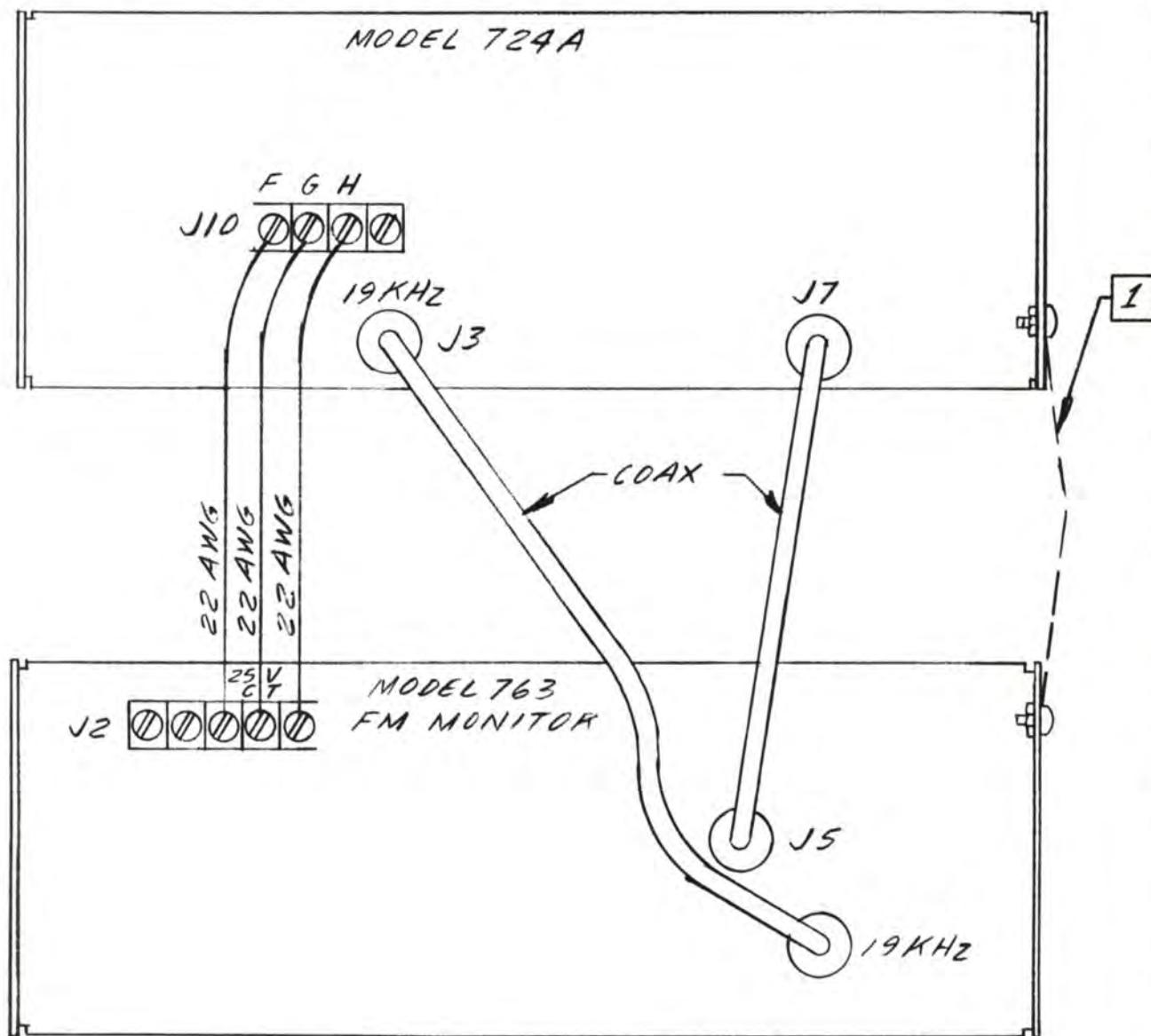

NOTE:

1. A GND WIRE OF 18 AWG OR LARGER MUST BE CONNECTED BETWEEN THE CHASSIS OF THE 724A AND 763

FIGURE 2-1

REAR PANEL INTERCONNECTIONS  
MODELS 763 AND 724A

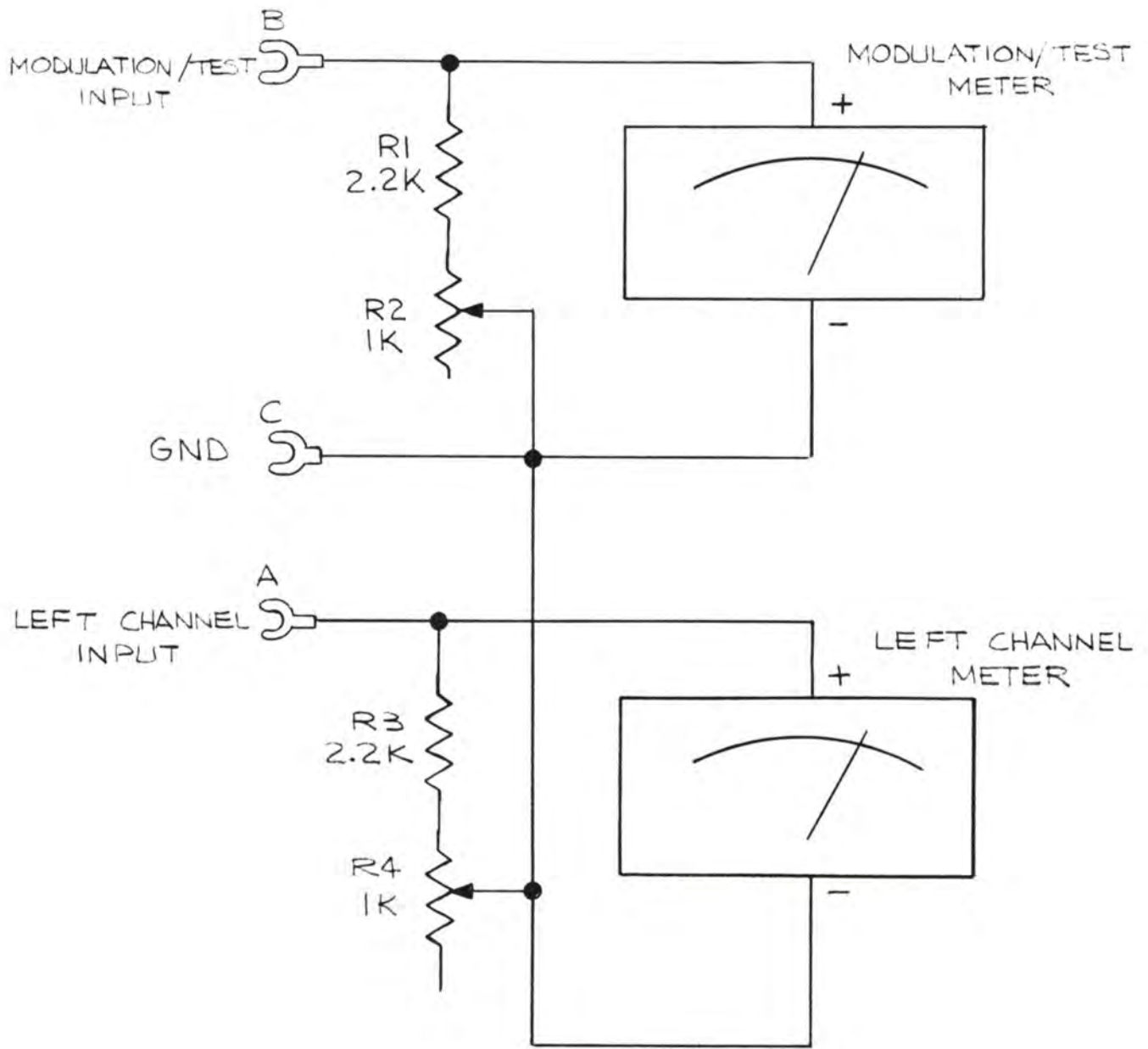

FIGURE 2-3

SECTION 3  
OPERATION

3.1 General.

The Model 724A Stereo Monitor provides all the functions required for the FCC proof-of-performance test, as well as for daily stereo system monitoring. Left and right channels can be monitored simultaneously. Built-in switchable attenuators permit making low-level measurements on signals that are small compared to the normal modulation. The internal calibration signal in the Model 763 FM Frequency and Modulation Monitor is used in conjunction with the LEVEL CAL control on the Model 724A rear panel and the MOD CAL/L+R button on the front panel to calibrate the Model 724A.

3.2 Controls, Connectors, and Indicators.

3.2.1 Front Panel.

Fig. 3-1  
Ref. No.

Name

Function

1

PHASE CAL switch and control

When the PHASE CAL switch is depressed, the PHASE CAL control can be adjusted for a null on the MODULATION/TEST meter to indicate that the internal 38 kHz signal is in phase with the 19 kHz pilot signal. This insures that the best channel separation has been attained so that the best stereo measurements can be made. Note: The null may not be a zero reading.

2

LEFT function switch

When depressed, the LEFT CHANNEL meter reads the left-channel-modulation unattenuated, and the MODULATION/TEST meter reads the left-channel modulation through the

3.2.1

Continued.

Fig. 3-1  
Ref. No.

Name

Function

		selected attenuator. Each meter will indicate 90% when the left channel is fully modulated.
3	RIGHT function switch	When depressed, the MODULATION/TEST meter reads the right-channel modulation through the selected attenuator. A fully modulated right channel will indicate 90% on the meter.
4	38 kHz function switch	With the stereo channel modulated at a frequency between 5 kHz and 15 kHz, depressing this permits reading the 38 kHz sub-carrier suppression on the MODULATION/TEST meter. By using the appropriate attenuator, measurements can be made to 60 dB below 100%.
5	PILOT function switch	When depressed, the MODULATION/TEST meter indicates the amplitude of the 19 kHz pilot signal through the selected attenuator allowing measurements over the required 8 to 10% range. These measurements can be made in the presence of modulation.
6	MOD CAL / L+R function	When depressed, the MODULATION/TEST meter indicates the amount of signal (attenuated by the selected attenuator)

3.2.1            (Continued).

Fig. 3-1  
Ref. No.

Name

Function

		in monophonic (main) channel in percent of 100% modulation. This switch is also used for calibrating the meters in conjunction with calibration signal from the Model 763.
7	L-R function switch	When depressed, the MODULATION/TEST meter indicates the amount of signal (attenuated by the selected attenuator) in the stereo channel in percent of 100% modulation.
8	FM S/N function switch	With all modulation turned off, depressing this switch causes the MODULATION/TEST meter to indicate the residual modulation (FM noise) through the selected attenuator. Depressing this switch automatically inserts a deemphasis network for this measurement.
9	METER OUTPUT	Provides an A.C. output of the signal that is being displayed on the MODULATION/TEST meter. Approximately 10VPP output into an open circuit represents 100% on the MODULATION/TEST meter.

3.2.1 (Continued).

Fig. 3-1  
Ref. No.

Ref. No.	Name	Function
10	MODULATION/TEST meter	Indicates the function switched in by the MOD/TEST METER FUNCTION switches. Inputs to this meter are always applied through a selected attenuator. Measurements can be made down to 70 dB below 100%.
11	MOD/TEST METER ATTENUATION switches	Depressing one of these switches inserts the attenuation marked thereon into the MODULATION/TEST meter input. The resulting measurement is the algebraic sum of the meter reading and the the inserted attenuation. For example, a meter indication of -2 dB with the -30 dB switch depressed would indicate a measurement of 32 dB below 100% modulation. Three of the switches are marked 1%, 10%, and 100%. These indicate the actual modulation percentage when the meter needle is a the 100% mark. For example, a meter reading of 70% with the 1% switch depressed would indicate a measurement of 0.7% modulation.
12	STEREO PILOT lamp	Lights when the 19 kHz pilot signal is present.

3.2.1 (Continued).

Fig. 3-1  
Ref. No.

	<u>Name</u>	<u>Function</u>
13	LEFT CHANNEL meter	Indicates left-channel modulation independent of selected function switch position.

3.2.2 Rear Panel.

Fig. 3-2  
Ref. No.

	<u>Name</u>	<u>Function</u>
1	DE-EMPHASIS RIGHT CHANNEL connector J1	Provides demodulation right-channel information through deemphasis network, for driving monitor systems etc.
2	DE-EMPHASIS LEFT CHANNEL connector J2	Provides demodulated left-channel information through deemphasis network, for driving monitor systems etc.
3	STEREO PILOT (19 kHz) connector J3	Provides means of delivering the 19 kHz component of the composite signal to the Model 764 or an external counter for frequency measurement.
4	RIGHT CHANNEL connector J4	Provides demodulated right-channel information, without deemphasis, for voltmeter measurements, etc.
5	LEFT CHANNEL connector J5	Provides demodulated left-channel information, without deemphasis, for voltmeter measurements, etc.



### 3.2.2 (Continued).

Fig. 3-2  
Ref. No.

	<u>Name</u>	<u>Function</u>
6	SCOPE OUTPUT connector J6	Provides demodulated composite signal for scope observation.
7	LEVEL CAL control	Controls amplitude of composite signal for calibration of front-panel meters.
8	COMPOSITE INPUT connector J7	Provides means of introducing a composite signal from the Model 763 or a stereo generator.
9	POWER SUPPLY FROM MODEL 763, J10, F, G, H	Provides means of supplying power from the Model 763 to the Model 724A.
10	Terminal block J10, A, B, C	Provides means of connecting a Model 704C Remote Panel Meter to the Model 724A.

### 3.3 Turn-On and Warm-Up.

The Model 724A is automatically turned on when the Model 763 is plugged in. Since the Model 724A is a completely solid-state design, warm-up time is very minimal. One or two minutes should be more than adequate to allow for consistent reading.

### 3.4 Calibration Procedures.

#### 3.4.1 Meter Calibration Using Model 763.

With the COMPOSITE INPUT connector J7 on the Model 724A connected to the composite output connector J5 on the Model 763 proceed as follows:

3.4.1 (Continued).

- a. Calibrate the Model 763 modulation meter as described in Model 763 instruction manual.
- b. On the Model 724A front panel depress the MOD CAL/L+R switch.
- c. On the Model 724A rear panel, adjust the LEVEL CAL control so that the MODULATION/TEST meter reads 100%.

3.4.2 Meter Calibration with a Composite Input.

With COMPOSITE INPUT connector J7 on the Model 724A connected to a composite-signal source, proceed as follows:

- a. On the Model 724A front panel, depress the PILOT switch.
- b. On the Model 724A rear panel, adjust the LEVEL CAL control so that the correct pilot signal level is indicated on the MODULATION/TEST meter, using the MOD/TEST METER ATTENUATION switches as required.
- c. The other portions of the composite signal should appear at their proper levels.

3.4.3 Phase Calibration.

- a. Remove all left-channel and right-channel audio modulation, leaving only the pilot signal as modulation.
- b. Depress the front-panel PHASE CAL switch.
- c. Adjust the front-panel PHASE CAL control for a minimum reading on the MODULATION/TEST meter. Note that this minimum reading will not be zero.

3.5 Use of the Model 724A for Monitoring.

For normal monitoring, press the RIGHT function switch and the 100% / 0 dB MOD/TEST METER ATTENUATION switch. The LEFT CHANNEL meter will then indicate the left-channel modulation percentage, and the MODULATION/TEST meter will indicate the right-channel modulation percentage simultaneously.

REVISIONS		
LTR	Description	Date
A	RELEASED TO PRODUCTION	
B	REVISED PER ECO 341	7-16-76

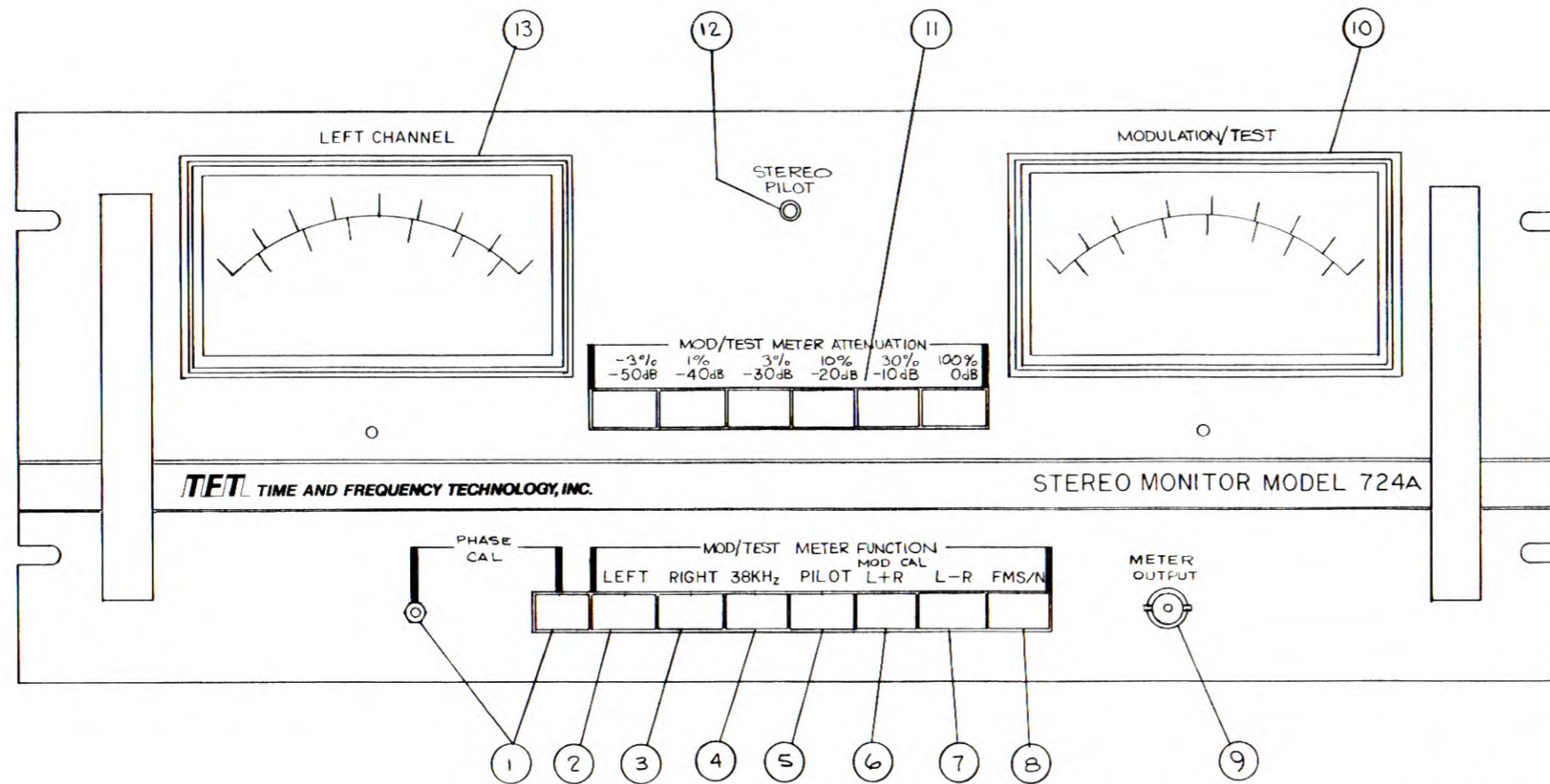

FIGURE 3-1

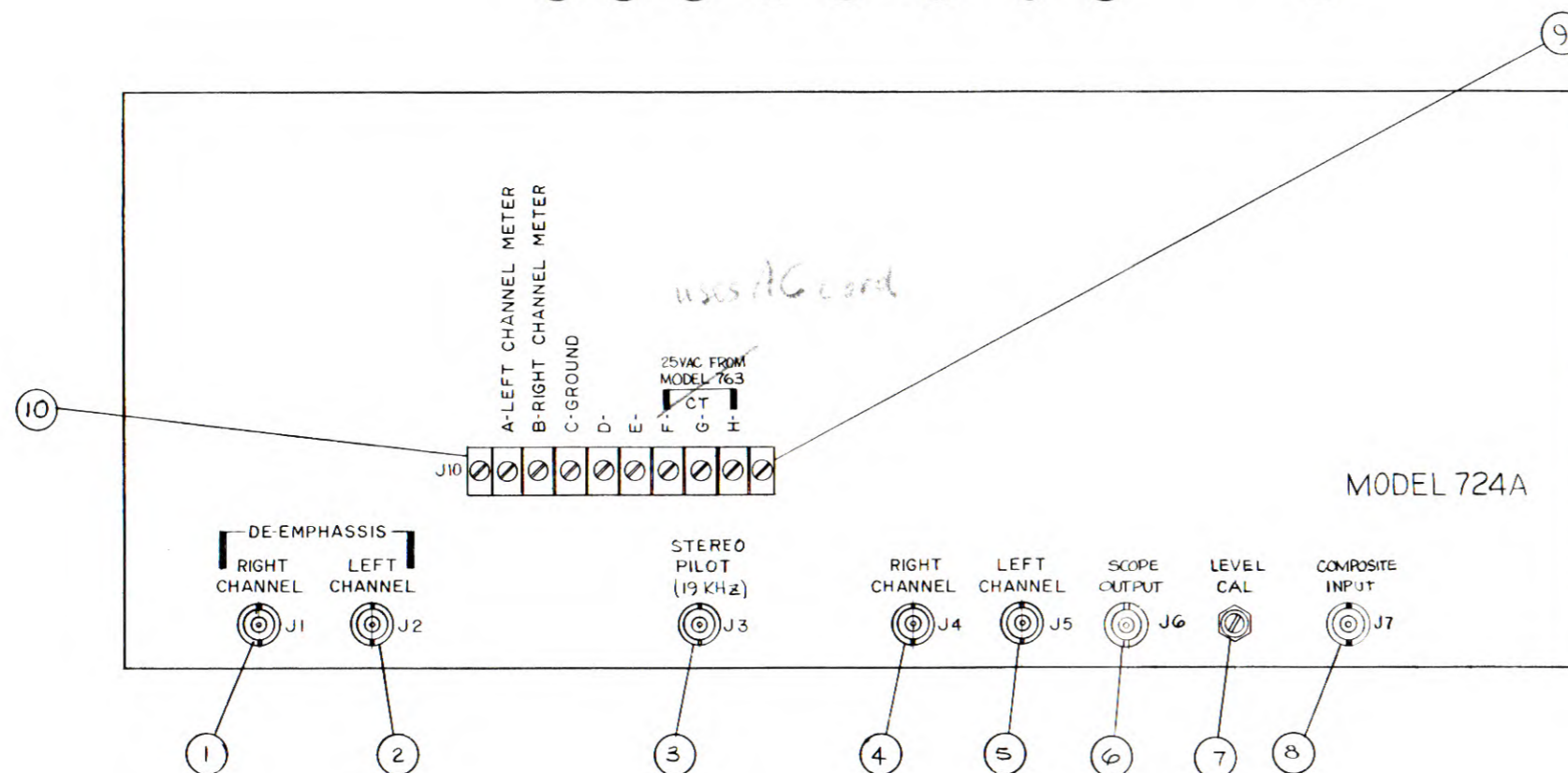

FIGURE 3-2

<b>TET</b> TIME AND FREQUENCY TECHNOLOGY, INC.		
SCALE 1/1	APPROVED BY	DRAWN BY DS
DATE 7-19-76	REVISIONS	
PANEL - FRONT & REAR		
MODEL 724A		DRAWING NUMBER 6600-0950

### 3.6 Use of the Model 724A for Measurements.

#### 3.6.1 Main-Channel (L+R) Modulation.

Press the MOD CAL / L+R function switch and the 100% / 0 dB MOD/TEST METER ATTENUATION switch. The MODULATION/TEST meter will indicate the main-channel modulation directly in percent. A fully modulated right or left channel only signal will indicate 45% on the meter. A fully modulated L=R signal will indicate 90% and a fully modulate L=-R signal will indicate 0.

#### 3.6.2 Stereo Subchannel (L-R) Modulation.

Press the L-R function switch and the 100% / 0 dB MOD/TEST METER ATTENUATION switch. The MODULATION/TEST meter will indicate the stereo subchannel modulation directly in percent. A fully modulated right or left channel only signal will indicate 45% on the modulation meter. A fully modulated L=-R signal will indicate 90% and a fully modulated L=R signal will indicate 0.

#### 3.6.3 Pilot Carrier Modulation.

Press the PILOT Function switch and the 10% / -20 dB MOD/TEST METER ATTENUATION switch. The MODULATION/TEST meter will indicate the pilot modulation level, with the 100% mark on the meter denoting 10% modulation. Correct pilot modulation level is between 8% and 10%. This measurement can be made in the presence of program modulation.

#### 3.6.4 38 kHz Subcarrier Suppression.

- a. Apply a modulating signal between 5 kHz and 15 kHz to the left channel of the transmitter under test, and adjust its level to indicate 90% on the LEFT CHANNEL meter.
- b. Press the 38 kHz function switch.
- c. With the MOD/TEST METER ATTENUATION switches, select an attenuation that provides a usable reading on the MODULATION/TEST meter. The 38 kHz subcarrier suppression is then the algebraic sum of the meter reading and the attenuation inserted. For example, a meter reading of -2 dB with the -50 dB MOD/TEST METER ATTENUATION switch depressed denotes a 38 kHz subcarrier suppression of 52 dB below 100% modulation.

3.6.5

Stereo Channel Separation (Left Channel Modulated).

- a. Apply a modulating signal between 50 Hz and 15 kHz to the left channel of the transmitter under test and adjust its level to indicate 90% on the LEFT CHANNEL meter.
- b. Press the RIGHT function switch.
- c. With the MOD/TEST METER ATTENUATION switches, select an attenuation that provides a usable reading on the MODULATION/TEST meter.
- d. The channel separation is the algebraic sum of the meter reading and the attenuation inserted, less approximately 1 dB (0.915 dB) to account for the 90% left-channel modulation level. For example, a meter reading of -2 dB with the 1% / -40 dB MOD/TEST METER ATTENUATION Switch depressed denotes a stereo channel separation of 41 dB.

3.6.6

Stereo Channel Separation (Right Channel Modulated).

- a. Press the RIGHT function switch.
- b. Press the 100% / 0 dB MOD/TEST METER ATTENUATION switch.
- c. Apply a modulating signal between 50 Hz and 15 kHz to the right channel of the transmitter under test and adjust its level to indicate 90% on the MODULATION/TEST meter.
- d. Press the LEFT function switch.
- e. With the MOD/TEST METER ATTENUATION switches, select an attenuation that provides a usable reading on the MODULATION/TEST meter.
- f. The channel separation is the algebraic sum of the meter reading and the attenuation inserted, less 1 dB to account for the 90% right-channel modulation level.

3.6.7

Main Channel to Subchannel Crosstalk.

- a. Press the MOD CAL / L+R function switch and the 100% / 0 dB MOD/TEST METER ATTENUATION switch.

3.6.7

(Continued).

- b. Apply an L=R modulating signal to the transmitter under test and adjust the level for a 90% reading on the MODULATION/TEST meter.
- c. Press the L-R function switch.
- d. With the MOD/TEST METER ATTENUATION switches, select an attenuation that provides a usable reading on the MODULATION/TEST meter.
- e. The crosstalk measure is the algebraic sum of the selected attenuation and the meter reading, less 1 dB to account for the 90% modulation setting.

3.6.8

Subchannel to Main Channel Crosstalk.

- a. Press the L-R function switch and the 100% / 0 dB MOD/TEST METER ATTENUATION switch.
- b. Apply an L=-R modulating signal to the transmitter under test and adjust the level for a 90% reading on the MODULATION/TEST meter.
- c. Press the L+R function switch.
- d. With the MOD/TEST METER ATTENUATION switches, select an attenuation that provides a usable reading on the MODULATION/TEST meter.
- e. The crosstalk measured is the algebraic sum of the selected attenuation and the meter reading, less 1 dB to account for the 90% modulation setting.

3.6.9

FM Noise.

- a. Turn off all transmitter modulation.
- b. Press the FM S/N switch.
- b. With the MOD/TEST METER ATTENUATION switches, select an attenuation that provides a usable reading on the MODULATION/TEST meter.
- d. The algebraic sum of the selected attenuation and the meter reading is the FM signal-to-noise ratio.

### 3.6.10 Distortion.

- a. Apply a modulating signal to the transmitter channel to be measured.
- b. Connect a distortion analyzer to the appropriate rear-panel connector -- RIGHT CHANNEL connector J1 or LEFT CHANNEL connector J2, if de-emphasis is desired; or RIGHT CHANNEL connector J5, if de-emphasis is not required.

### 3.6.11 Pilot Frequency.

When the rear-panel STEREO PILOT (19 kHz) connector J3 is connected to the Model 764 as described in step e of Paragraph 2.3, the pilot frequency can be measured by the counter on the Model 764. This signal can also be measured using an ordinary frequency counter.

### 3.7 Use of the Model 704C Remote Meter Panel.

When a Model 704C is connected to the Model 724A as described in Paragraph 2.4, the Model 704C meters will duplicate the readings of the Model 724A meters. Calibrating the Model 724A meters also calibrates the Model 704C meters.

## SECTION 4

### THEORY OF OPERATION

#### 4.1 General Block Diagram Discussion (Figure 6-1)

Two meters on the front panel of the Model 724A provide monitor and test indications. The LEFT CHANNEL meter reads left-channel modulation percentage. The MODULATION/TEST meter normally reads right-channel modulation percentage, but is also used for all the test functions selectable by the front-panel function switches.

##### 4.1.1 Modulation Monitoring Circuits

On Board A2, the composite signal from the input amplifier is applied to the stereo demodulator, where it is combined with a precision 38-kHz square wave derived from the 19 kHz pilot signal to provide the right-channel and left-channel audio outputs. During normal monitoring, the RIGHT function switch and the 0 dB attenuator switch are depressed. The function switches are mechanically ganged in such a way that when one is closed (depressed) all others are open. The right-channel output of the stereo demodulator is fed through a 15 kHz low-pass filter, the RIGHT function switch, and the selected attenuator to a detector, the DC output of which drives the MODULATION/TEST meter to indicate modulation percentage in the right channel. The right-channel output is also delivered to rear-panel RIGHT CHANNEL connector J4, and through a de-emphasis network to rear-panel DE-EMPHASIS RIGHT CHANNEL connector J1; these two outputs are present regardless of which function switch is depressed.

The left-channel stereo demodulator output is fed through a 15-kHz low-pass filter, amplifiers, detector, and to the LEFT CHANNEL meter. The left-channel output is also delivered to rearpanel LEFT CHANNEL connector J5, and through a de-emphasis network to rear-panel DE-EMPHASIS LEFT CHANNEL connector J2. The left-channel output can also be applied to the MODULATION/TEST meter through the attenuation network by depressing the LEFT function switch.

The precision 38-kHz square wave required by the stereo demodulator is supplied by a phase-locked loop. The 19-kHz pilot signal, extracted from the composite signal by the 19-kHz bandpass filter, is applied to the phase-locked loop as the reference signal. The 76-kHz output of the phase-locked loop is divided by two to provide 38-kHz for the stereo demodulator, and divided again by two to provide a 19-kHz comparison input to the phase-locked loop. Since the phase-locked loop, when properly adjusted, keeps the two 19-kHz inputs locked in phase, the 38-kHz output will also be locked to the 19-kHz reference, as required by the stereo demodulator.



#### 4.1.1 (Continued).

To adjust the phase-locked loop for proper phase lock, the front-panel PHASE CAL switch is depressed. This applies the 19-kHz component of the composite signal to the digital phase detector, where it is compared with the regenerated 19-kHz signal from the phase-locked loop. The output of the digital phase detector is a train of pulses whose width is proportional to the difference in phase between the two 19-kHz signals. A low-pass filter converts the pulses to a DC voltage, the magnitude of which is proportional to the phase difference. This voltage is amplified and applied to the MODULATION/TEST meter. The PHASE CAL Potentiometer in the phase-locked loop is then adjusted for the lowest meter reading, representing the minimum phase difference.

The 19-kHz phase-locked loop output is also furnished to rear-panel STEREO PILOT (19-kHz) connector J3. The output at J3 is fed to the Model 764 counter circuits for measuring the frequency of this regenerated 19-kHz signal.

#### 4.1.2 Measurement Circuits

The measurement circuits consist of filters to extract the desired information from the composite signal, the attenuator network with its selector switches, the MODULATION/TEST meter, and associated amplifiers and function switches.

The main-channel 15-kHz low-pass filter provides the main channel output for FM signal-to-noise measurement, left-plus-right (L+R) main-channel measurement, and MODULATION/TEST meter calibration. When the FM S/N switch is depressed, a de-emphasis network is inserted as required when making signal-to-noise measurements.

The left-minus-right (L-R) stereo-channel (23-53-kHz bandpass) filter provides the stereo-channel output for measurement of the amplitude of that component.

The 38-kHz bandpass filter extracts the pilot signal for measurement of its amplitude, and for input to the phase-locked loop. The pilot signal is also detected to drive the front-panel STEREO PILOT lamp.

#### 4.2 Meter Amplifier and Attenuator Board (A3).

(Circuit Diagram: Figure 6-3)

This board contains the switchable attenuator, detectors for both front-panel meters, and amplifiers to drive the audio outputs.

#### 4.2.1 Attenuator

The 2-volt RMS input at E1 is applied across the attenuator network consisting of R1 through R7. The desired attenuation is selectable in 10-dB steps by front-panel MOD/TEST METER ATTENUATION switches, which tap off at the appropriate point on the voltage-divider network. The attenuation switches are mechanically interconnected so that when one is depressed, all others are released. In addition, separate sections of switches SW4, SW5, and SW6 are wired to feed output buffer amplifier Z7 from the average detector, and separate sections of switches SW1, SW2, and SW3 are wired to feed Z7 from the peak detector. This is because SW1 (0 dB), SW2 (-10 dB), and SW3 (-20 dB) are used to measure signal voltages where peak values are significant, while SW4 (-30 dB), SW5 (-40 dB), and SW6 (-50 dB) are used to measure noise where average values are more significant than peak values. The two detectors are discussed in Section 4.2.2.

#### 4.2.2 Modulation/Test Meter Amplifier

The AC voltage selected by the attenuator is applied to buffer Q1, an emitter follower which presents a high impedance to the attenuator to prevent loading effects. The output of Q1 is amplified by Z9 and Z8, and fed to the average detector (CR3 and operational amplifier Z10) and to the peak detector (CR1 and C13). The output of one of the detectors is selected by the depressed attenuator switch, as described in Section 4.2.1, and fed through DC buffer amplifier Z7 and front-panel PHASE CAL switch A2SW1 to the MODULATION/TEST meter and rear-panel terminal J10-B.

#### 4.2.3 Left-Channel Meter Amplifier

This amplifier consists of operational amplifier Z5, detector CR2/R34/C22, and DC voltage follower Z6. Operational amplifier Z5 provides a gain of 2 for the left-channel signal at its input. Output voltage follower Z6 drives the LEFT CHANNEL meter and also feeds rear-panel terminal J10-A.

#### 4.2.4 Audio Amplifiers

The left-channel audio input is amplified 20 dB by operational amplifier Z4. The output of Z4 drives the left-channel meter amplifier (see Section 4.2.3), furnishes a 2-volt RMS open-circuit voltage to rear-panel connector J5 for a 100% modulated carrier and feeds operation amplifier Z3, which provides unity gain with standard de-emphasis to rear-panel connector J2.

Variable resistor R39 provides a means to adjust the reading on the LEFT CHANNEL meter so that it reads the same as the MODULATION/TEST meter when the front-panel LEFT/MOD/TEST METER FUNCTION switch is depressed.

#### 4.2.4 (Continued).

The right-channel audio circuits, consisting of amplifiers Z2 and A1 and switch Q3, operate similarly to the left-channel circuits.

#### 4.3 (Demodulator and Filter Board (A2))

(Circuit Diagram: Figure 6-4)

This is the main board of the Model 724A. It contains the stereo demodulator with its phase-locked loop; all the filters for extracting the various components of the composite signal; the function switches; the phase calibration circuit; and various buffer amplifiers. The buffers and function switches are described first because they are common to many of the other circuits.

##### 4.3.1 Buffer Amplifiers and Function Switches

Buffer amplifier Q1, which has a gain of 2, feeds stereo demodulator Z1, rear-panel SCOPE OUTPUT connector J6, the phase calibration circuit when front-panel PHASE CAL switch SW1 is depressed, and buffer Q2. Buffer Q2 is an emitter follower which drives the 19-kHz filter directly; and the 38-kHz filter, left-plus-right (L+R) filter FL1, and left-minus-right (L-R) filter FL2 through a buffer consisting of FET amplifier Q3 and emitter follower Q4.

The function switches are SW2 through SW8. The switches are mechanically interconnected so that only one can be depressed at a time. By means of these switches, the output of any one of the filters can be selected as the input to the meter attenuator on Board A3 through buffers Z2 and Z3. Potentiometers R15, R18, R21, R24, R27, and R30 are factory adjusted to provide a 200-millivolt level at pin 3 of Z2 for 100-percent modulation (MODULATION/TEST meter reading of 100%).

To satisfy the requirement that FM Signal-to-noise measurements be made through a 75-microsecond de-emphasis network, depressing FM S/N switch SW8 connects capacitor C30 across the output of L+R filter FL1. This capacitor in conjunction with R91 and associates components provides the required 75-microsecond de-emphasis network.

Operational amplifiers Z2 and Z3 provide a gain of precisely 10 for the filter outputs so that the level at E22 is precisely 2 volts for 100-percent modulation.

##### 4.3.2 19-kHz Filter

This is a three-pole Chebyshev bandpass filter with a 50-

#### 4.3.2 (Continued).

dB bandwidth of less than 8 kHz. It consists of the network between the emitter of Q2 and the base of Q5. The output of the filter is connected through level adjust potentiometer R15 to PILOT function switch SW5. The filter output is also supplied to the phase-locked loop and the 19-kHz detector through emitter follower Q5.

The 19-kHz detector, consisting of amplifier Q6, rectifier CR1, and DC amplifier Q7, lights the front-panel STEREO PILOT LED when there is a pilot carrier present in the composite input.

#### 4.3.3 38-kHz Filter

This is a three-pole Chebyshev bandpass filter with a 70-dB bandwidth of less than 10-kHz. It consists of the network between the emitter of Q4 and the junction of C19 and C20. Its output is delivered to 38-kHz function switch SW4 through level adjust potentiometer R18.

#### 4.3.4 L+R Channel Filter (FL1)

This is a seven-pole, elliptic-function, 15-kHz, low-pass filter. It rejects a 19-kHz frequency by more than 30 dB, and rejects frequencies between 23 and 53 kHz by more than 70 dB. Its output is delivered to both MOD CAL/L+R function switch SW6 and FM S/N function switch SW8 through level adjust potentiometer R21.

For calibrating the Model 724A MODULATION/TEST meter from the Model 763, the front-panel MOD CAL / L+R switch is depressed. The Model 763 furnishes a calibration signal with a frequency deviation of +75 kHz.

#### 4.3.5 L-R Channel Filter (FL2)

This is a bandpass filter with a pass band of 23 to 53 kHz. It provides more than 35 dB rejection at 19 kHz; more than 46 dB rejection from 59 to 75-kHz; and more than 60 dB rejection from 15-kHz to 50 Hz. Its output is delivered to L-R function switch SW7 through level adjust potentiometer R24.

#### 4.3.6 38-kHz Phase-Locked Loop

The complete phase-locked loop circuit consists of integrated-circuit phase-locked loop Z11, amplifier Q8, flip-flops Z9-15 and Z9-11, and associated circuitry. The 19-kHz pilot carrier from the 19-kHz filter is applied to pin 2 of Z11 as the reference signal. The voltage-controlled oscillator (VCO) contained in Z11 operates at 76 kHz, output at Z9-14 is fed to stereo demodulator Z1, and is also divided by

#### 4.3.6 (Continued)

2 in the second Z9 flip-flop to provide the comparison 19-kHz signal for pin 5 of Z11. The regenerated 19-kHz signal is also fed from Z9-10 to rear-panel STEREO PILOT connector J3 so that it can be cabled to the Model 764, where its frequency can be checked on the Model 764 counter. When this loop is properly adjusted, its 38-kHz output will be locked in phase with the 19-kHz pilot carrier, as required by the stereo demodulator. The phase of the 38-kHz carrier can be adjusted over a narrow range by the front-panel PHASE CAL potentiometer.

#### 4.3.7 Stereo Demodulator

Integrated-circuit dual differential amplifiers (Z1) are used as the stereo demodulator. The composite signal input is applied to Z1-3. The required 38-kHz stereo subcarrier comes from the phase-locked loop; thus no tuned circuits are required. This provides good stability, and minimum aging phase drift. Potentiometer R39 balances the 38-kHz drive to the stereo demodulator, and is adjusted for minimum 38-kHz feed-through. Variable resistor R48 adjusts the gain balance between the two halves of the demodulator for best overall separation. The left-channel output at Z1-14 and the right-channel output at Z1-1 are delivered to low-pass filters FL3 and FL4, respectively.

#### 4.3.8 Left-Channel Filter (FL3) and Right-Channel Filter (FL4)

There are two seven-pole, elliptic-function, 15-kHz, low-pass filters. Rejection at a frequency of 19-kHz is greater than 60 dB, and at frequencies between 23 and 53-kHz, is greater than 50 dB. The output of FL3 is delivered through level adjust potentiometer R27 to LEFT function switch SW2, and also to the left audio input (A3E7) on Board A3. The output of FL4 is delivered similarly to RIGHT function switch SW3 and the right audio input (A3E4) on Board A3.

#### 4.3.9 Phase Calibration Circuit

When front-panel PHASE CAL switch SW1 is depressed, the composite signal at E1 amplified by Q1 is applied to E7 and the noninverting input of zero crossing detector Z10. Since phase calibration is performed with all modulation removed, the composite signal will consist only of the 19-kHz pilot. The DC voltage at the inverting input of Z10 is factory adjusted by means of R70 so that Z10 operates as a zero-crossing detector and shapes the 19-kHz sine wave into a square wave that is precisely synchronized with the sine wave.

#### 4.3.9 (Continued)

Gates Z5, Z6, Z7 and Z8 comprise a digital phase detector. The regenerated 19-kHz signal from the phase-locked loop is applied from Z9-11 and Z9-10 to the phase detector; the shaped 19-kHz pilot signal from Z10-9 is also applied to the phase detector. The phase detector output at TP3 is a train of pulses whose width is proportional to the difference in phase between the two 19-kHz signals.

The pulses are amplified by Q10 and applied to the low-pass filter consisting of R80 and C69, which produces a DC output proportional to the average pulse width, and therefore proportional to the phase difference between the two 19-kHz signals. This DC voltage is amplified by Z4 and fed to the front-panel MODULATION/TEST meter through terminals 6 and 5 of the PHASE CAL switch. The DC output from Z4-6 is also fed through the PHASE CAL switch to rear-panel terminal J10-B for driving a Model 704C remote meter in the phase calibration mode.

During phase calibration, the phase of the VCO in Z11 is adjusted by the front-panel PHASE CAL control so that the DC output of Z4 is a minimum, indicating the least phase difference between the two 19-kHz signals.

#### 4.4 Power Supply Board (A1)

(Circuit Diagram: Figure 6-5)

This board contains the rectifiers, filters and regulators necessary to provide the +10 V, +12 V and -12 V used in the Model 724A.

SECTION 5  
MAINTENANCE

5.1           General.

Since the Model 724A is a solid-state instrument and its power requirements are low, no maintenance problems due to high temperature should be encountered, provided the instrument is installed well away from vacuum-tube and other heat-generating equipment. Likewise, because the operating voltages are low, excessive dust accumulation associated with high-voltage devices should not occur.

5.2           Periodic Maintenance.

The only periodic maintenance required is cleaning. Once a year, or more often in dusty locations, take off the top cover, and blow off dust with compressed air.

5.3           Performance Checks.

The following procedures will enable the technician to determine whether the instrument is operating properly. If the tests indicate substandard operation, it is recommended that the instrument be returned to the factory for adjustment or repair. Internal adjustments, particularly adjustments of the filters, should not be made in the field.

5.3.1        Calibration Accuracy Check.

- a. On the Model 763 front panel, depress either the METER (+) or METER (-) switch (not the METER CAL switch).
- b. Connect a 1-kHz output from an audio generator into the Model 724A rear-panel COMPOSITE INPUT connector J7.
- c. On the front-panel, depress the MOD CAL L+R function switch and the 0 dB attenuation switch.
- d. Adjust the level of the 1-kHz signal for a reading of 100% on the MODULATION/TEST meter. The LEFT CHANNEL meter should also read 100% +2%.
- e. Depress the LEFT and RIGHT function switches, one at a time. The MODULATION/TEST meter reading should remain at 100 +2%.

### 5.3.1

(Continued)

- f. Depress the MOD CAL L+R switch. Reduce the level of the 1-kHz input by 10 dB and depress the -10 dB attenuation switch. The MODULATION/TEST meter should again read 100%. Decrease the input level and attenuation in 10-dB steps through the attenuator range. The MODULATION/TEST meter should read 100% for each step.
- g. Depress the 0 dB attenuation switch, and readjust the signal generator output level for a 100% reading on the MODULATION/TEST meter. Without changing level, increase the input frequency to 2 kHz. Depress the FM S/N button. The MODULATION/TEST meter should read  $-3 \pm 0.5$  dB.
- h. Increase the input frequency to 19,000  $\pm 5$  Hz. Depress the PILOT function switch. The MODULATION/TEST meter should read 100  $\pm 2$ %.
- i. Increase the input frequency to 38,000  $\pm 10$  Hz. Depress the 38 kHz function switch. The MODULATION TEST meter should read 100  $\pm 2$ %.
- j. Without changing the input frequency or level, press the L-R function switch. The MODULATION/TEST meter should read 100  $\pm 2$ %.

### 5.3.2

Amplitude Response Check.

- a. With the audio generator connected as in the preceding section, adjust it for an output of 1 kHz at a level to produce a MODULATION/TEST meter reading of 100% with the 0 dB attenuator switch and the LEFT function switch depressed.
- b. Vary the input frequency from 50 Hz to 15 kHz. The MODULATION/TEST meter reading should remain 100  $\pm 4$ %. Repeat this check with the RIGHT switch depressed, and then with the MOD CAL L+R switch depressed. The meter reading should remain 100  $\pm 4$ %.
- c. Depress the L-R function switch. Adjust the input frequency to 38 kHz and the input level for a 100% reading on the MODULATION/TEST meter. Vary the input frequency from 23 kHz to 53 kHz. The meter reading should remain 100  $\pm 4$ %.



### 5.3.3 Stereo Pilot Indicator Check.

- a. With the audio generator connected as in the preceding sections, adjust its frequency to 19 kHz.
- b. Depress the PILOT function switch and the -20 dB attenuation switch.
- c. Adjust the generator level for a -6 dB reading on the MODULATION/TEST meter. This is equivalent to 5% total modulation.
- d. The STEREO PILOT lamp should be on.
- e. Remove the 19 kHz input signal. The STEREO PILOT lamp should go off.

### 5.3.4 Output Check

- a. Depress the MOD CAL L+R function switch and the 0 dB attenuation switch.
- b. With the audio generator connected as before, adjust its frequency to 400 Hz and its output level for a 100% reading on the MODULATION/TEST meter.
- c. Connect an AC voltmeter in turn to all four rear-panel audio outputs (J1, J2, J4, and J5). The reading for each output should be  $2 \pm 0.25$  V RMS (open circuit).
- d. Connect the AC voltmeter to the rear-panel SCOPE OUTPUT connector. The reading should be  $1 \pm 0.25$  V RMS (open circuit).
- e. Increase the input frequency to 2 kHz. The DE-EMPHASIS RIGHT CHANNEL and DE-EMPHASIS LEFT CHANNEL (J1 and J2) outputs should drop  $3.0 \pm 0.5$  dB. The two outputs without de-emphasis (J4 and J5) and the SCOPE OUTPUT (J6) should remain the same as in steps c and d above within  $\pm 4\%$ .
- f. Change the input frequency to 19 kHz and depress the -20 dB attenuation switch. Adjust the audio generator level for a full scale (10% Modulation) reading on the meter, with the PILOT function switch depressed.

5.3.4 (Continued).

- g. Connect an oscilloscope to rear-panel STEREO PILOT (19 kHz) connector J3. The oscilloscope display should be a square wave with an amplitude greater than 0.5 V peak-to-peak.

5.3.5 Stereo Separation Check.

- a. Connect the composite output of a stereo generator to rear-panel COMPOSITE INPUT connector J7.
- b. Depress the PILOT function switch and the -20 dB attenuation switch.
- c. Adjust the rear-panel LEVEL CAL potentiometer for a 100% reading on the MODULATION/TEST meter (10% pilot carrier level).
- d. Depress the PHASE CAL potentiometer for a minimum reading on the MODULATION/TEST meter. (The minimum reading will not necessarily be zero).
- f. Depress the RIGHT function switch and the 0 dB attenuation switch.
- g. Modulate the right channel only of the stereo generator with a 1-kHz signal.
- h. Adjust the level of the 1-kHz modulation for a 90% reading on the MODULATION/TEST meter.
- i. Depress the LEFT function switch and the -40 dB attenuation switch. The reading on the MODULATION/TEST meter should be at least 5 dB below that in step h. (This represents 45 dB separation).
- j. On the stereo generator, change the modulation to the left channel and check the right channel on the MODULATION/TEST meter. The right channel should be at least 45 dB below 90%.
- k. Vary the stereo generator modulation frequency from 50 Hz to 15 kHz for steps i and j. (Note: It is important that the stereo generator separation be greater than 45 dB at the frequency extremes. Refer to the stereo generator instruction manual for the method of checking this). The reading on the MODULATION/TEST meter should remain as in steps i and j over the frequency range of 50 Hz to 15 kHz.

### 5.3.6

#### Crosstalk and Distortion Check.

##### Crosstalk Into L+R Channel

- a. Connect the output of an audio signal generator into rear-panel COMPOSITE INPUT connector J7.
- b. Set the generator frequency to 23 kHz.
- c. On the Model 724A front panel depress the L-R function switch and the 0 dB attenuation switch.
- d. Adjust the generator output level for a 100% reading on the MODULATION/TEST meter.
- e. Depress the MOD CAL L+R function switch and the -50 dB attenuation switch.
- f. The MODULATION/TEST meter should read less than -10 dB. On the Meter with the -50 dB button depressed (-50 dB).
- g. Sweep the audio frequency from 23 kHz to 75 kHz. The reading on the MODULATION/TEST meter should remain below -10 dB.

##### Crosstalk Into L-R Channel

- a. Depress the L-R function switch and the -20 dB attenuation switch.
- b. Set the generator frequency to 38 kHz.
- c. Reduce the signal generator output level for a 100% reading on the MODULATION/TEST meter (10% carrier modulation).
- d. Increase the generator frequency to 59 kHz, and depress the - 50dB attenuation switch. The MODULATION/TEST meter reading should be below -16 dB. (-66 dB)
- e. Increase the generator frequency to 75 kHz. The MODULATION/TEST meter reading should remain below - 16 dB (-66 dB)
- f. Set the generator frequency to 38 kHz.
- g. Depress the 0 dB attenuation switch, and adjust the generator output level for 100% on the MODULATION/TEST meter.

5.3.6

(Continued).

- h. Reduce the generator frequency to 15 kHz and depress the -50 dB switch. The MODULATION/TEST meter should read more than -10 dB down. (-60 dB) (Note: The signal generator used in this test must have a total harmonic distortion of less than 0.1%; i.e., the second and third harmonics must be more than 60 dB down).

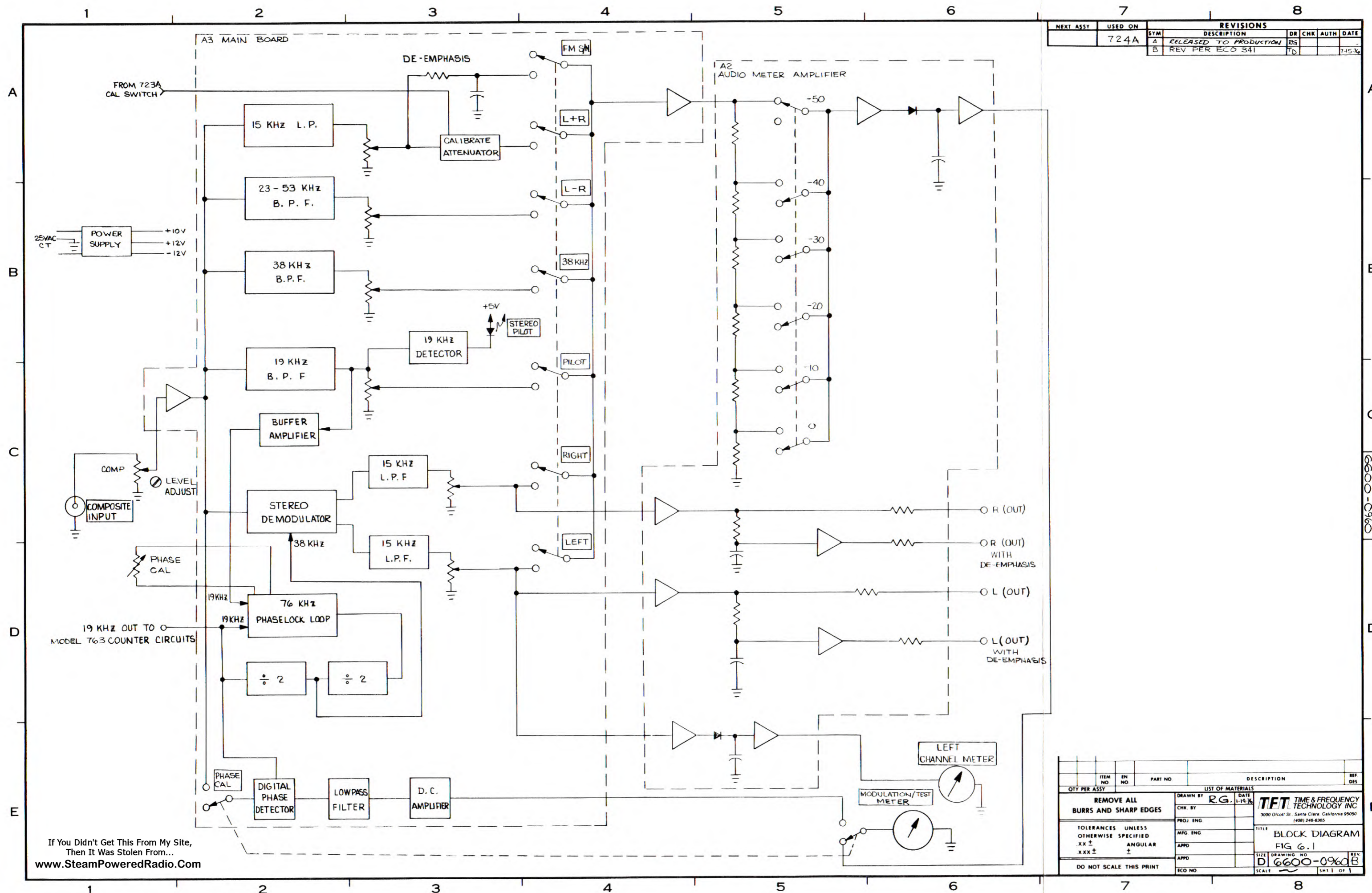

NEXT ASSY		USED ON		REVISIONS			
SYM	DESCRIPTION	DR	CHK	AUTH	DATE		
724A		RG			7-15-76		
A	RELEASED TO PRODUCTION						
B	REV PER ECO 341						

ITEM NO	EN NO	PART NO	DESCRIPTION	REF DES
QTY PER ASSY				
LIST OF MATERIALS				
REMOVE ALL BURRS AND SHARP EDGES				
DRAWN BY		DATE	TFT TIME & FREQUENCY TECHNOLOGY INC	
CHK BY		1-19-76	3000 Olcott St. Santa Clara, California 95050	
PROJ ENG			(408) 248-6305	
MFG ENG			TITLE BLOCK DIAGRAM	
APPD			FIG 6.1	
APPD			SIZE DRAWING NO	
ECO NO			D 6600-096d B	
DO NOT SCALE THIS PRINT		SCALE		SHT 1 OF 1

If You Didn't Get This From My Site,  
Then It Was Stolen From...  
[www.SteamPoweredRadio.Com](http://www.SteamPoweredRadio.Com)

NEXT ASSY		USED ON		REVISIONS			
SYM	DESCRIPTION	OR	CHK	AUTH	DATE		
A	RELEASED TO PRODUCTION	RG				7-16-76	
B	REV PER ECO 341	Td					

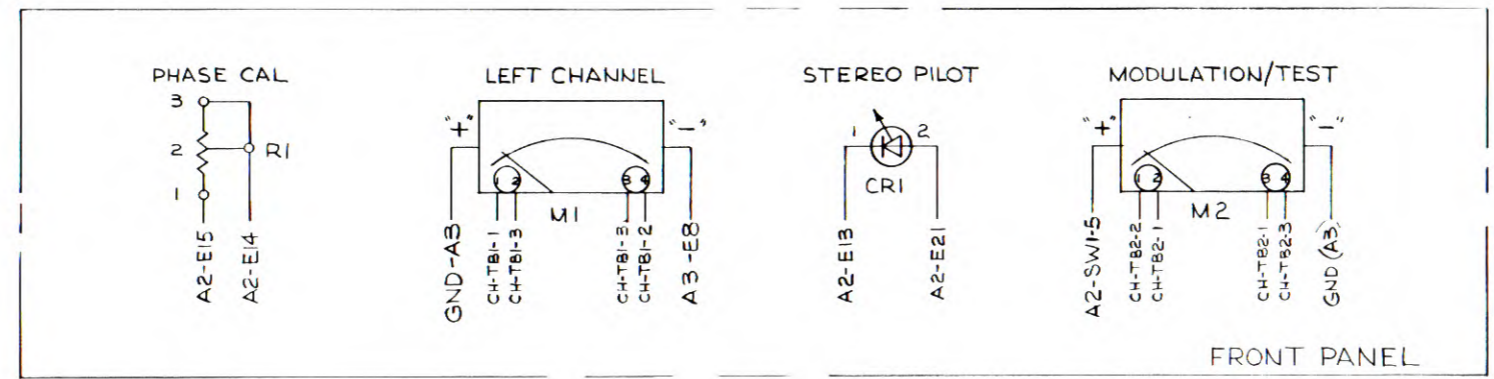
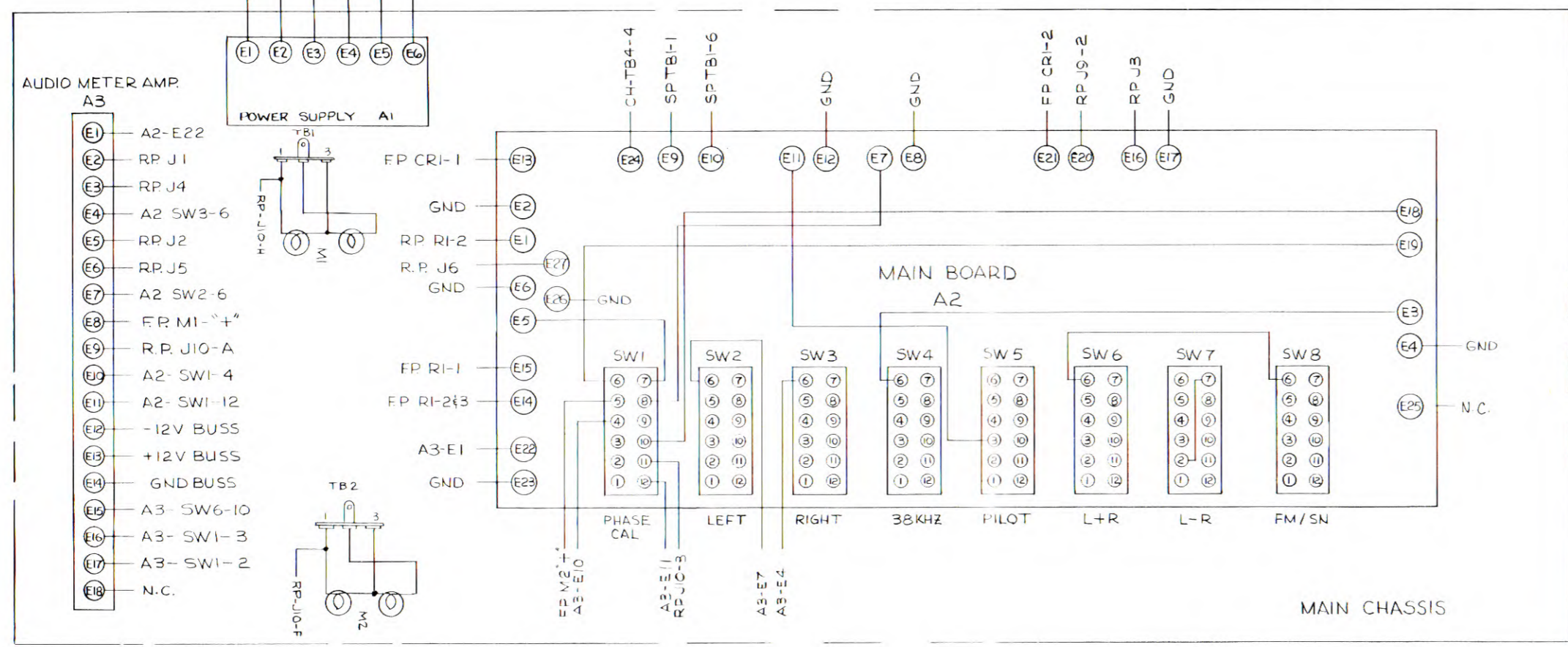
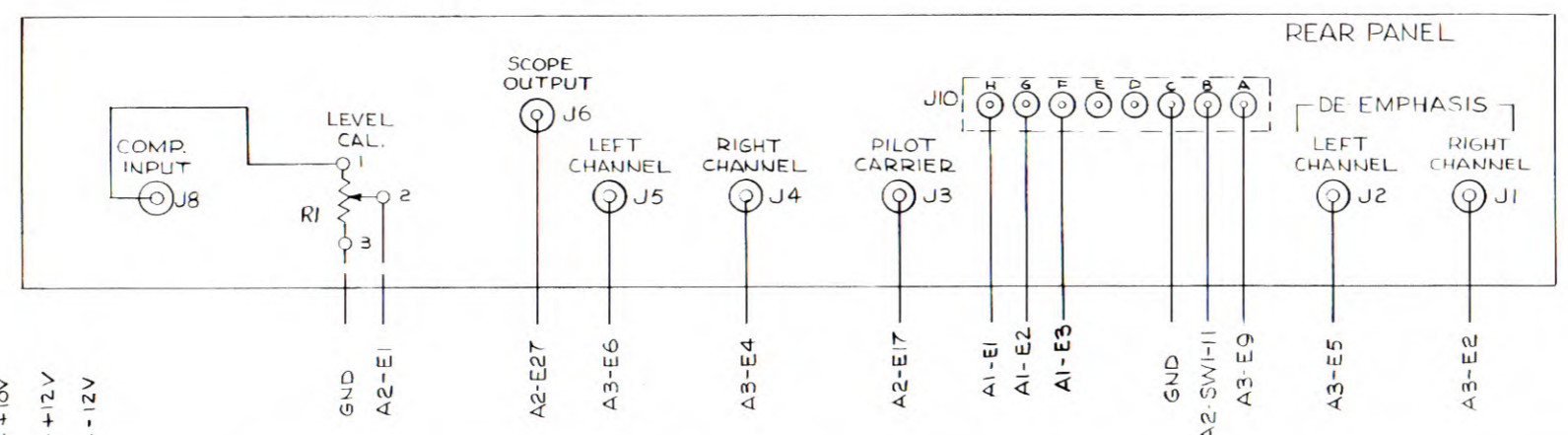

If You Didn't Get This From My Site,  
Then It Was Stolen From...  
[www.SteamPoweredRadio.Com](http://www.SteamPoweredRadio.Com)

ITEM NO	EN NO	PART NO	DESCRIPTION	REF DES
QTY PER ASSY				
LIST OF MATERIALS				
REMOVE ALL BURRS AND SHARP EDGES				
DRAWN BY NS.		DATE 8/16/76		
CHK BY		TFT TIME & FREQUENCY TECHNOLOGY INC		
PROJ ENG		3000 Dicot St., Santa Clara, California 95050		
MFG ENG		(408) 246-6365		
APPD		TITLE WIRING DIAGRAM FIG. 6.2		
ECO NO		SIZE D		REV B
		DRAWING NO 6600-0970		SHT 1 OF 1

DWG. NO. 6600-0970

NEXT ASSY		USED ON		REVISIONS			
SYM	DESCRIPTION	DR	CHK	AUTH	DATE		
A	RELEASED TO PRODUCTION	EG			7-16-76		
B	REV PER ECO 341	TD					

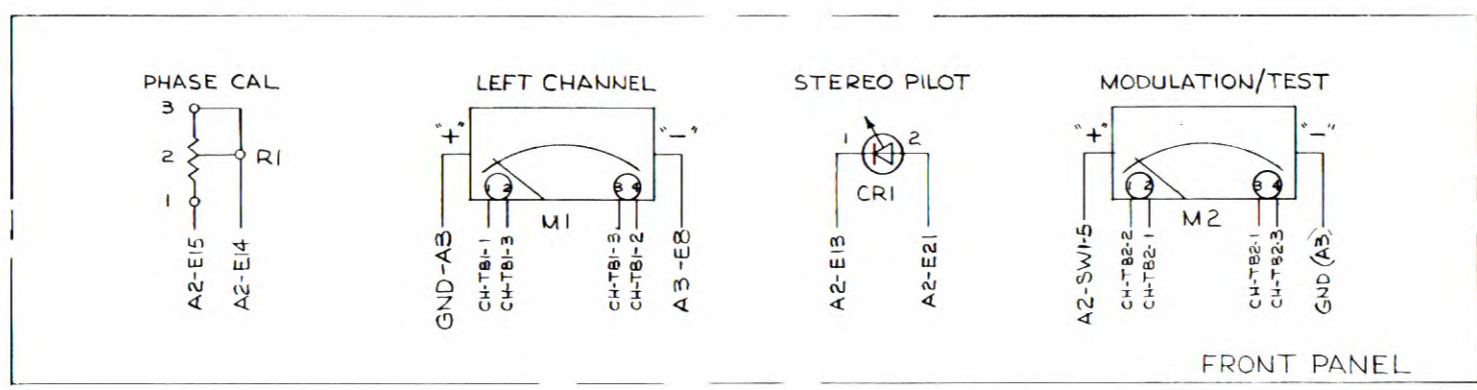
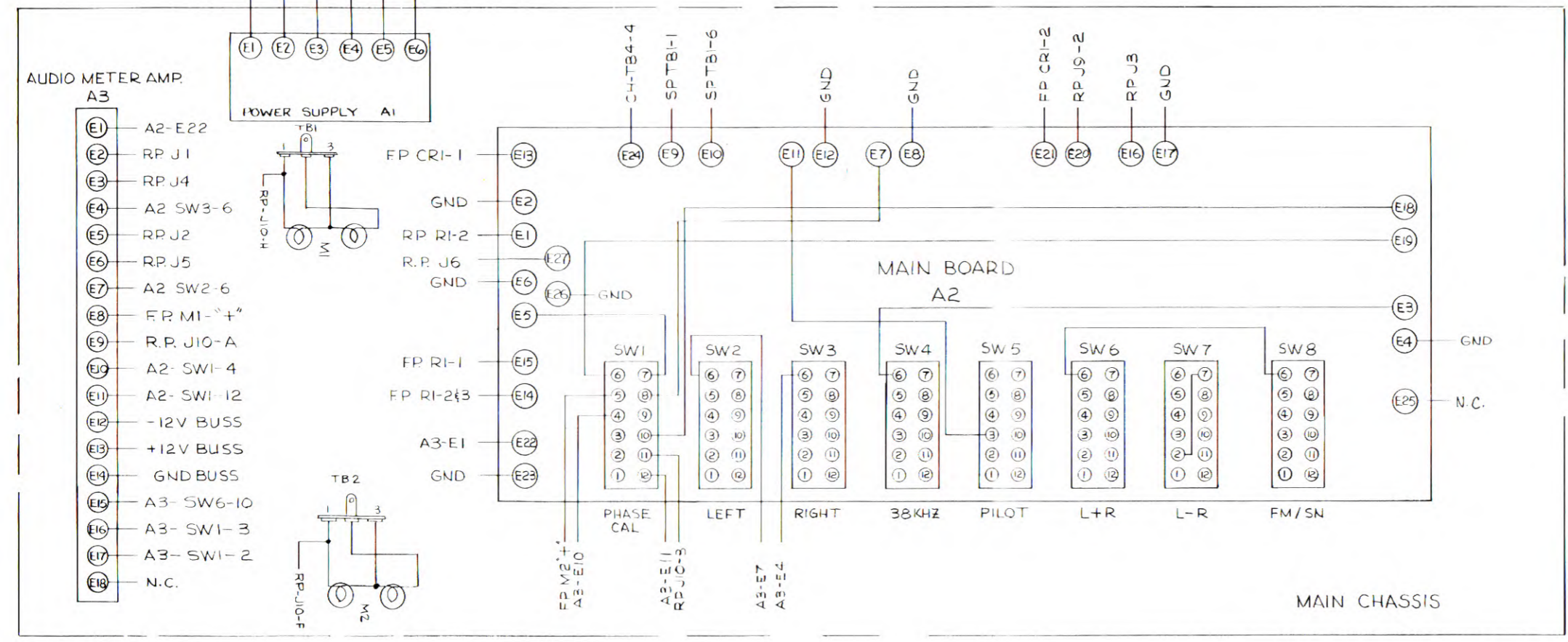
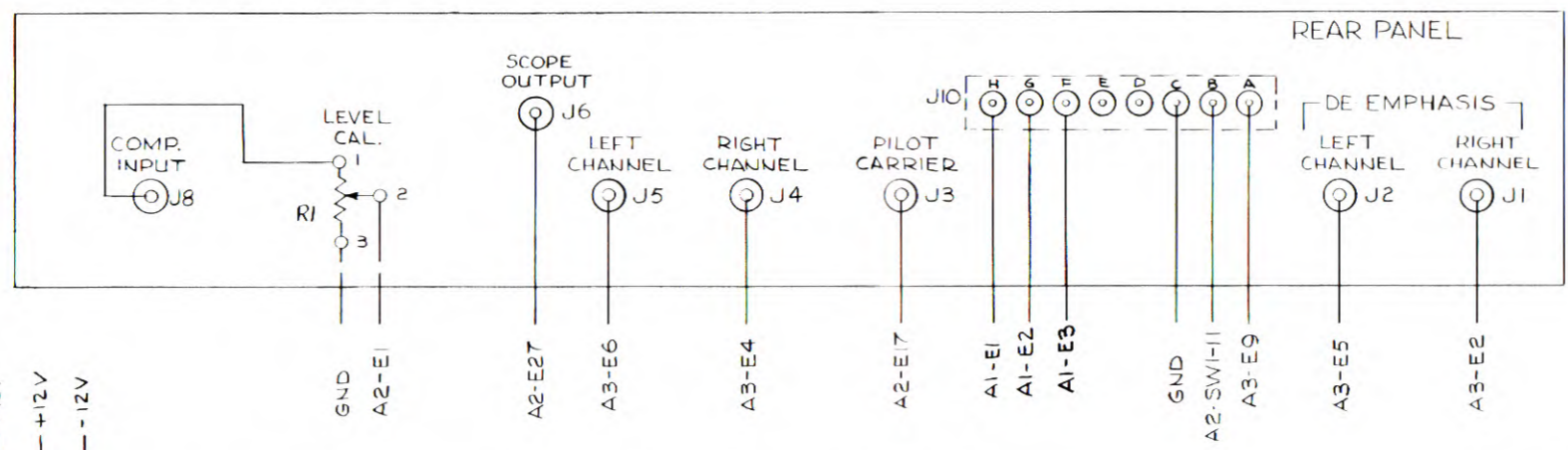

- AUDIO METER AMP A3**
- (E1) A2-E22
  - (E2) RP J1
  - (E3) RP J4
  - (E4) A2 SW3-6
  - (E5) RP J2
  - (E6) RP J5
  - (E7) A2 SW2-6
  - (E8) F.P. M1-"
  - (E9) R.P. J10-A
  - (E10) A2-SWI-4
  - (E11) A2-SWI-12
  - (E12) -12V BUSS
  - (E13) +12V BUSS
  - (E14) GND BUSS
  - (E15) A3-SW6-10
  - (E16) A3-SWI-3
  - (E17) A3-SWI-2
  - (E18) N.C.

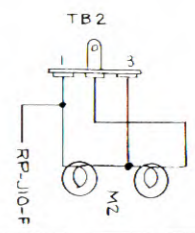
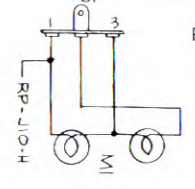
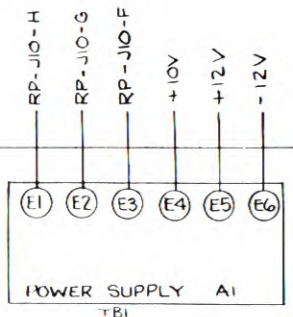

If You Didn't Get This From My Site,  
Then It Was Stolen From...  
[www.SteamPoweredRadio.Com](http://www.SteamPoweredRadio.Com)

QTY PER ASSY	ITEM NO.	EN NO.	PART NO.	DESCRIPTION	REF. DES.
LIST OF MATERIALS					
REMOVE ALL BURRS AND SHARP EDGES		DRAWN BY N.S.		DATE 8/14/76	
TOLERANCES UNLESS OTHERWISE SPECIFIED		PROJ. ENG.		MFG. ENG.	
.XX ±		ANGULAR ±		APPD.	
.XXX ±		APPD.		ECO NO.	
DO NOT SCALE THIS PRINT		SCALE		SHEET 1 OF 1	

**TFT** TIME & FREQUENCY TECHNOLOGY INC  
3000 Dillcott St. Santa Clara, California 95050  
(408) 248-8565

TITLE: WIRING DIAGRAM  
FIG. 6.2  
DRAWING NO: D 6600-0970  
REV: B

Model 724A

Meter Board Assy

Assembly # 6608-0430

Ckt. Ref.	Description	TFT Stock No.
C1	Cap Elect 25 Mfd 6V	1010-0250
C2	Cap Elect 1.0 Mfd 25V	1010-0010
C3	Cap Elect 25 Mfd 6V	1010-0250
C4	Cap Tub 2.2 PF	1000-0022
C5	Cap Mica 150 PF	1001-0151
C6	Cap Elect 15 Mfd 25V	1010-0150
C7	Cap Elect 25 Mfd 6V	1010-0250
C8	Cap Mica 1000 PF	1001-0102
C9	Cap Tub 2.2 PF	1000-0022
C10	Cap Mica 150 PF	1001-0151
C11	Cap Elect 15 Mfd 25V	1010-0150
C12	Cap Elect 220UF 16V	1010-0221
C13	Cap Poly .22 Mfd 100V	1002-0220
C14	Cap Tan 5.6 Mfd 35V 10%	1008-0056
C15	Cap Tan 5.6 Mfd 35V 10%	1008-0056
C16	Cap Elect 15 Mfd 25V	1010-0150
C17	Cap Elect 15 Mfd 25V	1010-0150
C18	Cap Poly .0082 Mfd 100V	1002-0822
C19	Cap Mica 10 PF	1001-0100
C20	Cap Mica 150 PF	1001-0151
C21	Cap Elect 220UF 16V	1010-0221
C22	Cap Poly .22 Mfd 100V	1002-0220
C23	Cap Tan 2.2 Mfd 20V 10%	1008-0022
C24	Cap Tan 2.2 Mfd 20V 10%	1008-0022
C25	Cap Elect 15 Mfd 25V	1010-0150
C26	Cap Mica 10 PF	1001-0100
C27	Cap Mica 150 PF	1001-0151
C28	Cap Poly .0082 Mfd 100V	1002-0822
C29	Cap Elect 25 Mfd 6V	1010-0250
C30	Cap Elect 25 Mfd 6V	1010-0250
C31	Cap Mica 10 PF	1001-0100
C32	Cap Mica 150 PF	1001-0151
C33	Cap Poly .0082 Mfd 100V	1002-0822
C34	Cap Mica 12 PF	1001-0120
C35	Cap Elect 25 Mfd 6V	1010-0250
C37	Cap Mica 30 PF	1001-0300
C38	Cap Mica 30 PF	1001-0300
C39	Cap Mica 30 PF	1001-0300
CR1	Dio, Hot Carrier, HP 5082-2800	1282-2800
CR2	Dio, Hot Carrier, HP 5082-2800	1282-2800
CR3	Dio, Hot Carrier, HP 5082-2800	1282-2800
CR4	Dio, Hot Carrier, HP 5082-2800	1282-2800



Model 724A

Meter Board Assy

Assembly # 6608-0430

Ckt. Ref.	Description	TFT Stock No.
CR5	Dio, Hot Carrier, HP 5082-3064	1282-3064
J1	Plug 2 Pin	2250-6002
J2	Plug, 3 Pin	2250-6003
J3	Plug 7 Pin Molex	2250-6007
J4	Plug 6 Pin	2250-6006
J5	Plug 7 Pin Molex	2250-6007
J6	Plug, 3 Pin	2250-6003
L1	Choke RF 100UH	1530-0101
L2	Choke RF 100UH	1530-0101
L3	Choke RF 100UH	1530-0101
L4	Choke RF 100UH	1530-0101
Q1	Xistor 2N5087	1271-5087
R1	Res Mt Flm 1/8W 1% 1.37K	1061-1370
R2	Res Mt Flm 1/8W 1% 432.	1061-0432
R3	Res Mt Flm 1/8W 1% 137.	1061-0137
R4	Res Mt Flm 1/8W 1% 43.2	1061-0043
R5	Res Mt Flm 1/8W 1% 13.7	1061-0013
R6	Res Mt Flm 1/8W 1% 12.7	1061-0012
R7	Res Mt Flm 1/8W 1% 12.7	1061-0012
R8	Res Car Comp 1/4W 5% 100K	1065-1003
R9	Res Car Comp 1/4W 5% 1K	1065-1001
R10	Res Car Comp 1/4W 5% 100K	1065-1003
R11	Res Car Comp 1/4W 5% 100K	1065-1003
R12	Res Car Comp 1/4W 5% 100	1065-0100
R13	Res Car Comp 1/4W 5% 10K	1065-1002
R14	Res Car Comp 1/4W 5% 330	1065-0330
R15	Res Car Comp 1/4W 5% 10K	1065-1002
R16	Res Car Comp 1/4W 5% 10K	1065-1002
R17	Res Car Comp 1/4W 5% 10.	1065-0010
R18	Res Car Comp 1/4W 5% 560	1065-0560
R19	Res Car Comp 1/4W 5% 10K	1065-1002
R20	Res Car Comp 1/4W 5% 10K	1065-1002
R21	Res Car Comp 1/4W 5% 10K	1065-1002
R22	Res Car Comp 1/4W 5% 3M	1065-3004
R23	Res Car Comp 1/4W 5% 10K	1065-1002
R24	Res Car Comp 1/4W 5% 10	1065-0010
R25	Res Var PC Mt 1K 10T	1069-1001
R26	Res Car Comp 1/4W 5% 680	1065-6802
R27	Res Car Comp 1/4W 5% 5.6K	1065-5601
R28	Res Car Comp 1/4W 5% 10K	1065-1002
R29	Res Car Comp 1/4W 5% 5.6K	1065-5601
R30	Res Car Comp 1/4W 5% 390K	1065-3903

Model 724A

Meter Board Assy

Assembly # 6608-0430

Ckt. Ref.	Description	TFT Stock No.
R31	Res Car Comp 1/4W 5% 22K	1065-2202
R32	Res Car Comp 1/4W 5% 10K	1065-1002
R33	Res Car Comp 1/4W 5% 10K	1065-1002
R34	Res Car Comp 1/4W 5% 1.1M	1065-1104
R35	Res Car Comp 1/4W 5% 5.6K	1065-5601
R36	Res Car Comp 1/4W 5% 5.6K	1065-5601
R37	Res Car Comp 1/4W 5% 10K	1065-1002
R38	Res Car Comp 1/4W 5% 10K	1065-1002
R39	Pot 10K 1T	1072-1002
R40	Res Car Comp 1/4W 5% 1K	1065-1001
R41	Res Car Comp 1/4W 5% 10K	1065-1002
R42	Res Car Comp 1/4W 5% 10K	1065-1002
R43	Res Car Comp 1/4W 5% 10K	1065-1002
R44	Res Car Comp 1/4W 5% 10K	1065-1002
R45	Res Car Comp 1/4W 5% 560	1065-0560
R46	Res Car Comp 1/4W 5% 560	1065-0560
R47	Res Car Comp 1/4W 5% 4.7K	1065-4701
R48	Res Car Comp 1/4W 5% 1.2K	1065-1201
R49	Res Car Comp 1/4W 5% 10K	1065-1002
R50	Res Car Comp 1/4W 5% 10K	1065-1002
R51	Res Car Comp 1/4W 5% 10K	1065-1002
R52	Res Car Comp 1/4W 5% 10K	1065-1002
R53	Res Car Comp 1/4W 5% 560	1065-0560
R54	Res Car Comp 1/4W 5% 560	1065-0560
R55	Res Car Comp 1/4W 5% 10K	1065-1002
R56	Res Car Comp 1/4W 5% 12K	1065-1202
R57	Res Car Comp 1/4W 5% 2.2K	1065-2201
R58	Res Car Comp 1/4W 5% 5.6K	1065-5601
R59	Res Car Comp 1/4W 5% 330K	1065-3303
R60	Res Car Comp 1/4W 5% 820	1065-0820
R61	Res Car Comp 1/4W 5% 2.2K	1065-2201
R64	Res Car Comp 1.4W 5% 5.1K	1065-5101
R65	Res Car Comp 1/4W 5% 1K	1065-1001
R66	Res Car Comp 1/4W 5% 100K	1065-1003
S1	Switch P/B 6XF20 Std	1850-0061
Z1	I/C LM 741CN	1100-0741
Z2	I/C LM301	1100-0301
Z3	I/C LM 741CN	1100-0741
Z4	I/C LM301	1100-0301
Z5	I/C LM301	1100-0301
Z6	I/C LM308N	1100-0308
Z7	I/C LM308N	1100-0308

Model 724A

Meter Board Assy

Assembly # 6608-0430

Ckt. Ref.	Description	TFT Stock No.
Z8 Z9 Z10	I/C LM301 I/C LM301 I/C LM301 Xistor Socket 3 Pin Socket, I/C 8 Pin	1100-0301 1100-0301 1100-0301 1150-0001 2250-1008 1600-0430

NEXT ASSY		USED ON		REVISIONS				
SYM	DESCRIPTION	DR	CHK	AUTH	DATE			
6608-0430	724A	A						
		B						

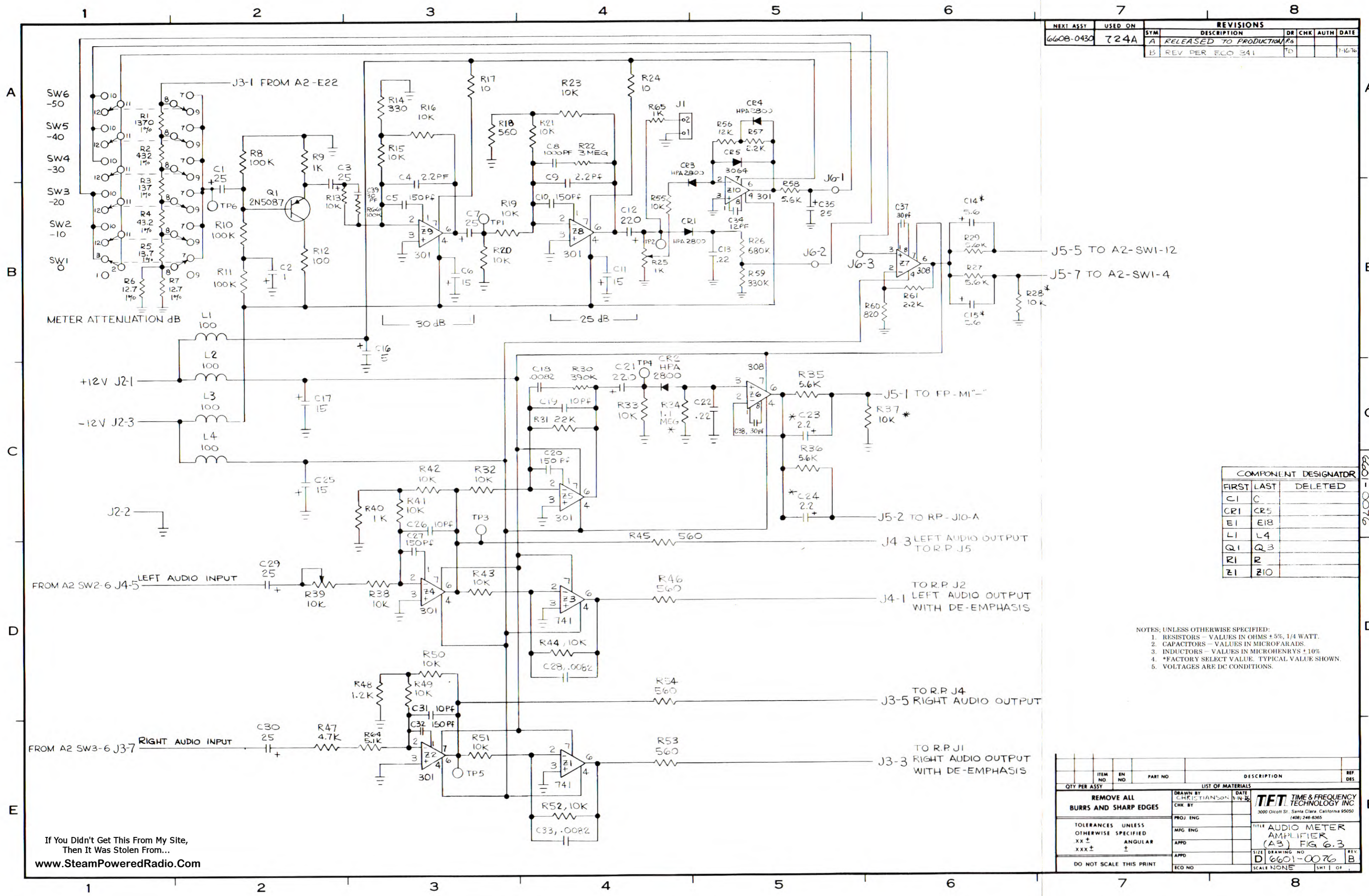

COMPONENT DESIGNATOR		
FIRST	LAST	DELETED
C1	C	
CR1	CR5	
E1	E18	
L1	L4	
Q1	Q3	
R1	R	
Z1	Z10	

NOTES, UNLESS OTHERWISE SPECIFIED:  
 1. RESISTORS - VALUES IN OHMS ± 5%, 1/4 WATT.  
 2. CAPACITORS - VALUES IN MICROFARADS.  
 3. INDUCTORS - VALUES IN MICROHENRYS ± 10%.  
 4. \*FACTORY SELECT VALUE. TYPICAL VALUE SHOWN.  
 5. VOLTAGES ARE DC CONDITIONS.

QTY PER ASSY	ITEM NO.	EN NO.	PART NO.	DESCRIPTION	REF DES

REMOVE ALL BURRS AND SHARP EDGES		LIST OF MATERIALS	
DRAWN BY	DATE	DRAWN BY	DATE
CHRISTIANSON	1-14-76	CHRISTIANSON	1-14-76
CHK BY		CHK BY	
PROJ ENG		PROJ ENG	
MFG ENG		MFG ENG	
APPD		APPD	
APPD		APPD	
ECO NO.		ECO NO.	

TOLERANCES UNLESS OTHERWISE SPECIFIED		ANGULAR	
XX ±		±	
XXX ±		±	

  

DO NOT SCALE THIS PRINT		SCALE NONE	
SHEET NO.		REV. DES.	

If You Didn't Get This From My Site,  
 Then It Was Stolen From...  
[www.SteamPoweredRadio.Com](http://www.SteamPoweredRadio.Com)

DWG NO. 6601-0076

E

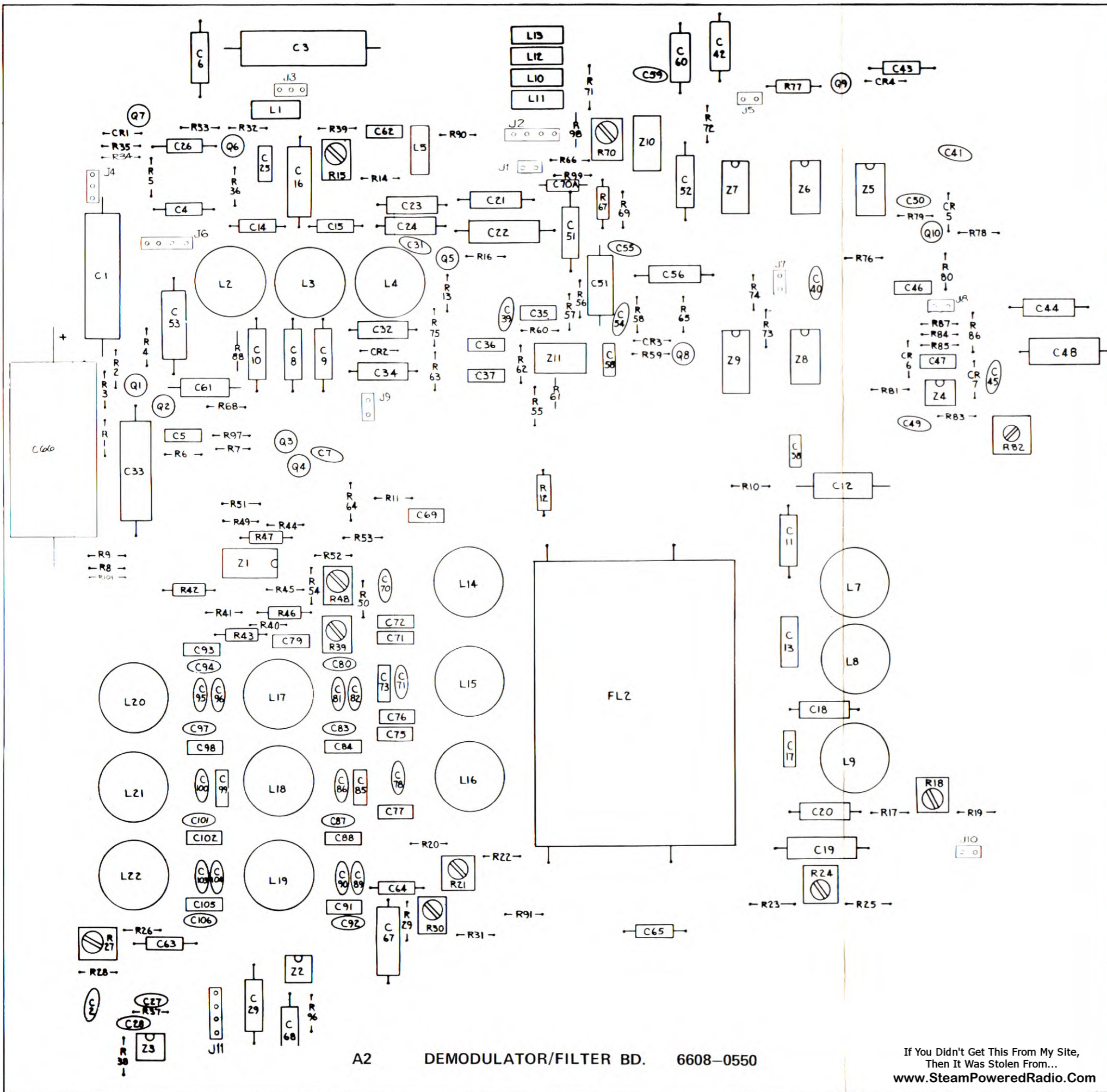

If You Didn't Get This From My Site,  
Then It Was Stolen From...  
[www.SteamPoweredRadio.Com](http://www.SteamPoweredRadio.Com)

Model 724A

Demodulator/Filter Bd

Assembly # 6608-0550

Ckt. Ref.	Description	TFT Stock No.
C1	Cap Elect 100 Mfd 15V	1010-0102
C2	Cap Cer Disc .05 Mfd	1005-5039
C3	Cap Elect 470 UF	1010-0471
C4	Cap Tan 10 Mfd 20V 10%	1008-0100
C5	Cap Poly .22 Mfd 100V	1002-0220
C6	Cap Elect 15 Mfd 25V	1010-0150
C7	Cap Cer Disc .05 Mfd	1005-5039
C8	Cap Poly 6200 PF 500V	1003-9622
C9	Cap Poly .039 Mfd 50V	1003-0391
C10	Cap Poly 1500 PF 500V	1003-9152
C11	Cap Poly 2400 PF 500V	1003-9242
C12	Cap Poly 4700 PF 500V	1003-9472
C13	Cap Poly 22 PF 500V	1003-9220
C14	Cap Poly 150 PF 500V	1003-9151
C15	Cap Poly 180 PF 500V	1003-9181
C16	Cap Poly 6200 PF 500V	1003-9622
C17	Cap Poly 27 PF 500V	1003-9270
C18	Cap Poly 1500 PF 500V	1003-9152
C19	Cap Poly 4700 PF 500V	1003-9472
C20	Cap Poly 2400 PF 500V	1003-9242
C21	Cap Poly 10,000 PF 100V	1003-9103
C22	Cap Poly 6200 PF 500V	1003-9622
C23	Cap Poly 10,000 PF 100V	1003-9103
C24	Cap Poly 750 PF 500V	1003-9751
C25	Cap Poly .1 Mfd 100V	1002-0010
C26	Cap Elect 1.0 Mfd 25V	1010-0010
C27	Cap Tub 6.8 PF	1000-0068
C28	Cap Mica 150 PF	1001-0151
C29	Cap Elect 25 Mfd 6V	1010-0250
C30	Cap Poly .018 Mfd 100V	1002-0181
C31	Cap Cer Disc .05 Mfd	1005-5039
C32	Cap Elect 15 Mfd 25V	1010-0150
C33	Cap Elect 470 UF	1010-0471
C34	Cap Elect 15 Mfd 25V	1010-0150
C35	Cap Poly .1 Mfd 100V	1002-0010
C36	Cap Poly .22 Mfd 100V	1002-0220
C37	Cap Poly .22 Mfd 100V	1002-0220
C38	Cap Poly .1 Mfd 100V	1002-0010
C39	Cap Cer Disc .05 Mfd	1005-5039
C40	Cap Cer Disc .05 Mfd	1005-5039
C41	Cap Cer Disc .05 Mfd	1005-5039
C42	Cap Elect 1.0 Mfd 25V	1010-0010

Model 724A

Demodulator/Filter Bd

Assembly # 6608-0550

Ckt. Ref.	Description	TFT Stock No.
C43	Cap Elect 1.0 Mfd 25V	1010-0010
C44	Cap Elect 15 Mfd 25V	1010-0150
C45	Cap Cer Disc .05 Mfd	1005-5039
C46	Cap Elect 1.0 Mfd 25V	1010-0010
C47	Cap Poly .1 Mfd 100V	1002-0010
C48	Cap Elect 15 Mfd 25V	1010-0150
C49	Cap Cer Disc .05 Mfd	1005-5039
C50	Cap Mica 10 PF	1001-0100
C51	Cap Elect 15 Mfd 25V	1010-0150
C52	Cap Elect 15 Mfd 25V	1010-0150
C53	Cap Mylar 1 Mfd 500V 10%	1004-0001
C54	Cap Cer Disc .05 Mfd	1005-5039
C55	Cap Cer Disc .05 Mfd	1005-5039
C56	Cap Elect 15 Mfd 25V	1010-0150
C57	Cap Elect 15 Mfd 25V	1010-0150
C58	Cap Mica 1000 PF	1001-0102
C59	Cap Cer Disc .05 Mfd	1005-5039
C60	Cap Elect 15 Mfd 25V	1010-0150
C61	Cap Cer Disc .2 Mfd	1005-2029
C62	Cap Poly .01 Mfd 100V	1002-0011
C63	Cap Tan 10 Mfd 20V 10%	1008-0100
C64	Cap Tan 10 Mfd 20V 10%	1008-0100
C65	Cap Tan 10 Mfd 20V 10%	1008-0100
C66	Cap Elect 4000 Mfd 16V	1010-4001
C67	Cap Elect 15 Mfd 25V	1010-0150
C68	Cap Elect 15 Mfd 25V	1010-0150
C69	Cap Poly .1 Mfd 100V	1002-0010
C69A	Cap Mica 2000 PF	1001-0202
C70	Cap Mica 220 PF	1001-0221
C70A	Cap Poly .01 Mfd 100V	1002-0011
C71	Cap Mica 2000 PF	1001-0202
C72	Cap Mica 1500 PF	1001-0152
C73	Cap Mica 1000 PF	1001-0102
C74	Cap Mica 82 PF	1001-0820
C75	Cap Mica 2000 PF	1001-0202
C76	Cap Mica 1500 PF	1001-0152
C77	Cap Mica 2000 PF	1001-0202
C78	Cap Mica 820 PF	1001-0821
C79	Cap Mica 1500 PF	1001-0152
C80	Cap Mica 820 PF	1001-0821
C81	Cap Mica 22 PF	1001-0220
C82	Cap Mica 300 PF	1001-0301

Model 724A

Demodulator/Filter Bd

Assembly # 6608-0550

Ckt. Ref.	Description	TFT Stock No.
C83	Cap Mica 300 PF	1001-0301
C84	Cap Mica 2700 PF	1001-0272
C85	Cap Mica 1700 PF	1001-0172
C86	Cap Mica 220 PF	1001-0221
C87	Cap Mica 560 PF	1001-0561
C88	Cap Mica 2000 PF	1001-0202
C89	Cap Mica 1000 PF	1001-0102
C90	Cap Mica 120 PF	1001-0121
C91	Cap Mica 1000 PF	1001-0102
C92	Cap Mica 470 PF	1001-0470
C93	Cap Mica 1500 PF	1001-0152
C94	Cap Mica 820 PF	1001-0821
C95	Cap Mica 22 PF	1001-0220
C96	Cap Mica 300 PF	1001-0301
C97	Cap Mica 300 PF	1001-0301
C98	Cap Mica 2700 PF	1001-0272
C99	Cap Mica 1700 PF	1001-0172
C100	Cap Mica 220 PF	1001-0221
C101	Cap Mica 560 PF	1001-0561
C102	Cap Mica 2000 PF	1001-0202
C103	Cap Mica 1000 PF	1001-0102
C104	Cap Mica 120 PF	1001-0121
C105	Cap Mica 1000 PF	1001-0102
C106	Cap Mica 470 PF	1001-0471
CR1	Dio IN3064	1281-3064
CR2	Dio ZNR IN4737	1283-4737
CR3	Dio ZNR IN4737	1283-4737
CR4	Dio ZNR IN4734A	1283-4734
CR5	Dio, Hot Carrier, HP 5082-2800	1282-2800
CR6	Dio IN3064	1281-3064
CR7	Dio IN3064	1281-3064
FL2	Filt 23-53 kHz	1052-0025
J1	Plug 2 Pin	2250-6002
J2	Plug, 4 Pin	2250-6004
J3	Plug, 3 Pin	2250-6003
J4	Plug, 3 Pin	2250-6003
J5	Plug 2 Pin	2250-6002
J6	Plug, 4 Pin	2250-6004
J7	Plug 2 Pin	2250-6002
J8	Plug 2 Pin	2250-6002
J9	Plug 2 Pin	2250-6002
J10	Plug 2 Pin	2250-6002



Model 724A

Demodulator/Filter Bd

Assembly # 6608-0550

Ckt Ref.	Description	TFT Stock No.
J11	Plug, 4 Pin	2250-6004
L1	Choke RF 15 UH	1530-0150
L2	M/L Ind Var 250T	1550-0250
L3	M/L Ind Var 250T	1550-0250
L4	M/L Ind Var 250T	1550-0250
L5	Choke RF 15 UH	1530-0150
L7	M/L Ind Var 250T	1550-0250
L8	M/L Ind Var 250T	1550-0250
L9	M/L Ind Var 250T	1550-0250
L10	Choke RF 15 UH	1530-0150
L11	Choke RF 15 UH	1530-0150
L12	Choke RF 15 UH	1530-0150
L13	Choke RF 15 UH	1530-0150
L14	M/L Ind Var 365T	1550-0370
L15	M/L Ind Var 330T	1550-0330
L16	M/L Ind Var 330T	1550-0330
L17	M/L Ind Var 365T	1550-0370
L18	M/L Ind Var 288T	1550-0288
L19	M/L Ind Var 300T	1550-0300
L20	M/L Ind Var 365T	1550-0370
L21	M/L Ind Var 288T	1550-0288
L22	M/L Ind Var 300T	1550-0300
Q1	Xistor 2N2222	1271-2222
Q2	Xistor 2N3565	1271-3565
Q3	Xistor TIS58	1271-0058
Q4	Xistor 2N3565	1271-3565
Q5	Xistor 2N3565	1271-3565
Q6	Xistor 2N3565	1271-3565
Q7	Xistor 2N4275	1271-4275
Q8	Xistor 2N4275	1271-4275
Q9	Xistor 2N3053	1271-3053
R1	Res Car Comp 1/4W 5% 560	1065-0560
R2	Res Car Comp 1/4W 5% 1K	1065-1001
R3	Res Car Comp 1/4W 5% 2.2K	1065-2201
R4	Res Car Comp 1/4W 5% 5.6K	1065-5601
R5	Res Car Comp 1/4W 5% 3.9K	1065-3901
R6	Res Car Comp 1/4W 5% 1K	1065-1001
R7	Res Car Comp 1/4W 5% 1M	1065-1004
R8	Res Car Comp 1/4W 5% 10K	1065-1002
R9	Res Car Comp 1/4W 5% 1K	1065-1001
R10	Res Car Comp 1/4W 5% 9.1K	1065-9101
R11	Res Car Comp 1/4W 5% 5.6K	1065-5601

Model 724A

Demodulator/Filter Bd

Assembly # 6608-0550

Ckt. Ref.	Description	TFT Stock No.
R12	Res Mt Flm 1/8W 1% 1K	1061-1001
R13	Res Car Comp 1/4W 5% 24K	1065-2402
R14	Res Car Comp 1/4W 5% 18K	1065-1802
R15	Pot PC Mt 2K 1T	1070-2001
R16	Res Car Comp 1/4W 5% 4.7K	1065-4701
R17	Res Car Comp 1/4W 5% 5.6K	1065-5601
R18	Pot PC Mt 2K 1T	1070-2001
R19	Res Car Comp 1/4W 5% 5.6K	1065-5601
R20	Res Car Comp 1/4W 5% 1.5K	1065-1501
R21	Pot PC Mt 1K 1T	1072-1001
R22	Res Car Comp 1/4W 5% 1.5K	1065-1501
R23	Res Mt Flm 1/8W 1% 402.	1061-0402
R24	Pot PC Mt 100 OHM 1T	1072-0100
R25	Res Mt Flm 1/8W 1% 499.	1061-0499
R26	Res Car Comp 1/4W 5% 10.	1065-0010
R27	Pot PC Mt 1K 1T	1072-1001
R28	Res Car Comp 1/4W 5% 3.3K	1065-3301
R29	Res Car Comp 1/4W 5% 10.	1065-0010
R30	Pot PC Mt 1K 1T	1072-1001
R31	Res Car Comp 1/4W 5% 3.3K	1065-3301
R32	Res Car Comp 1/4W 5% 10K	1065-1002
R33	Res Car Comp 1/4W 5% 1K	1065-1001
R34	Res Car Comp 1/4W 5% 150	1065-0150
R35	Res Car Comp 1/4W 5% 10K	1065-1002
R36	Res Car Comp 1/4W 5% 100	1065-0100
R37	Res Car Comp 1/4W 5% 10K	1065-1002
R38	Res Car Comp 1/4W 5% 1K	1065-1001
R39	Pot PC Mt 1K 1T	1072-1001
R40	Res Car Comp 1/4W 5% 4.7K	1065-4701
R41	Res Car Comp 1/4W 5% 10K	1065-1002
R42	Res Car Comp 1/4W 5% 5.1K	1065-5101
R43	Res Car Comp 1/4W 5% 5.1K	1065-5101
R44	Res Car Comp 1/4W 5% 1K	1065-1001
R45	Res Car Comp 1/4W 5% 1K	1065-1001
R46	Res Mt Flm 1/8W 1% 825.	1061-0825
R47	Res Mt Flm 1/8W 1% 825.	1061-0825
R48	Pot PC Mt 100 Ohm 1T	1072-0100
R49	Res Car Comp 1/4W 5% 10K	1065-1002
R50	Res Car Comp 1/4W 5% 4.7K	1065-4701
R51	Res Car Comp 1/4W 5% 7.5K	1065-7501
R52	Res Car Comp 1/4W 5% 10K	1065-1002
R53	Res Car Comp 1/4W 5% 4.7K	1065-4701

Model 724A

Demodulator/Filter Bd

Assembly # 6608-0550

Ckt. Ref.	Description	TFT Stock No.
R54	Res Car Comp 1/4W 5% 220	1065-0220
R55	Res Car Comp 1/4W 5% 2.7K	1065-2701
R56	Res Car Comp 1/4W 5% 3.3K	1065-3301
R57	Res Car Comp 1/4W 5% 3.3K	1065-3301
R58	Res Car Comp 1/4W 5% 390	1065-0390
R59	Res Car Comp 1/4W 5% 3.3K	1065-3301
R60	Res Car Comp 1/4W 5% 27K	1065-2702
R61	Thermistor 1K	1080-0013
R62	Res Car Comp 1/4W 5% 4.7K	1065-4701
R63	Res Car Comp 1/4W 5% 1K	1065-1001
R64	Res Car Comp 1/4W 5% 3.3K	1065-3301
R65	Res Car Comp 1/4W 5% 1K	1065-1001
R66	Res Car Comp 1/4W 5% 1K	1065-1001
R67	Res Mt Flm 1/8W 1% 47.5K	1061-4752
R68	Res Car Comp 1/4W 5% 1K	1065-1001
R69	Res Car Comp 1/4W 5% 1K	1065-1001
R70	Pot 10K 1T	1072-1002
R71	Res Mt Flm 1/8W 1% 47.5K	1061-4752
R72	Res Car Comp 1/4W 5% 100	1065-0100
R73	Res Car Comp 1/4W 5% 4.7K	1065-4701
R74	Res Car Comp 1/4W 5% 1K	1065-1001
R75	Res Car Comp 1/4W 5% 390	1065-0390
R76	Res Car Comp 1/4W 5% 10.	1065-0010
R77	Res Car Comp 1/2W 5% 560.	1066-0560
R78	Res Car Comp 1/4W 5% 4.7K	1065-4701
R79	Res Car Comp 1/4W 5% 3.3K	1065-3301
R80	Res Car Comp 1/4W 5% 56K	1065-5602
R81	Res Car Comp 1/4W 5% 1K	1065-1001
R82	Pot 10K 1T	1072-1002
R83	Res Car Comp 1/4W 5% 33K	1065-3302
R84	Res Car Comp 1/4W 5% 3.3K	1065-3301
R85	Res Car Comp 1/4W 5% 8.2K	1065-8201
R86	Res Car Comp 1/4W 5% 1.5K	1065-1501
R87	Res Car Comp 1/4W 5% 1.5K	1065-1501
R88	Res Car Comp 1/4W 5% 10K	1065-1002
R89	Res Car Comp 1/4W 5% 3.3K	1065-3301
R90	Res Car Comp 1/4W 5% 47K	1065-4702
R91	Res Car Comp 1/4W 5% 3.3K	1065-3301
R96	Res Car Comp 1/4W 5% 680K	1065-6803
R97	Res Car Comp 1/4W 5% 1K	1065-1001
R98	Res Car Comp 1/4W 5% 100	1065-0100
R99	Res Car Comp 1/4W 5% 1K	1065-1001

Model 724A

Demodulator/Filter Bd

Assembly # 6608-0550

Ckt. Ref.	Description	TFT Stock No.
R100	Res Car Comp 1/4W 5% 4.7K	1065-4701
R101	Res Car Comp 1/4W 5% 10.	1065-0010
Z1	I/C CA3054	1100-3054
Z2	I/C LM741CN	1100-0741
Z3	I/C LM301	1100-0301
Z4	I/C LM 741CN	1100-0741
Z5	I/C SN7400N	1100-7400
Z6	I/C SN7400N	1100-7400
Z7	I/C SN7400N	1100-7400
Z8	I/C SN7400N	1100-7400
Z9	I/C SN7476N	1100-7476
Z10	I/C LM710CN	1100-0710
Z11	I/C NE565A	1100-0565
	Xistor Socket 3 Pin	1150-0001
	Switch P/B 8XF20	1850-0080
	Heat Sink Fan Top	2010-0320
	Socket, I/C 8 Pin	2250-1008
	Socket, I/C 14 Pin	2250-1014
	Socket, I/C 16 Pin	2250-1016
	Plug 2 Pin	2250-6002
	PC Bd 724	1600-0600

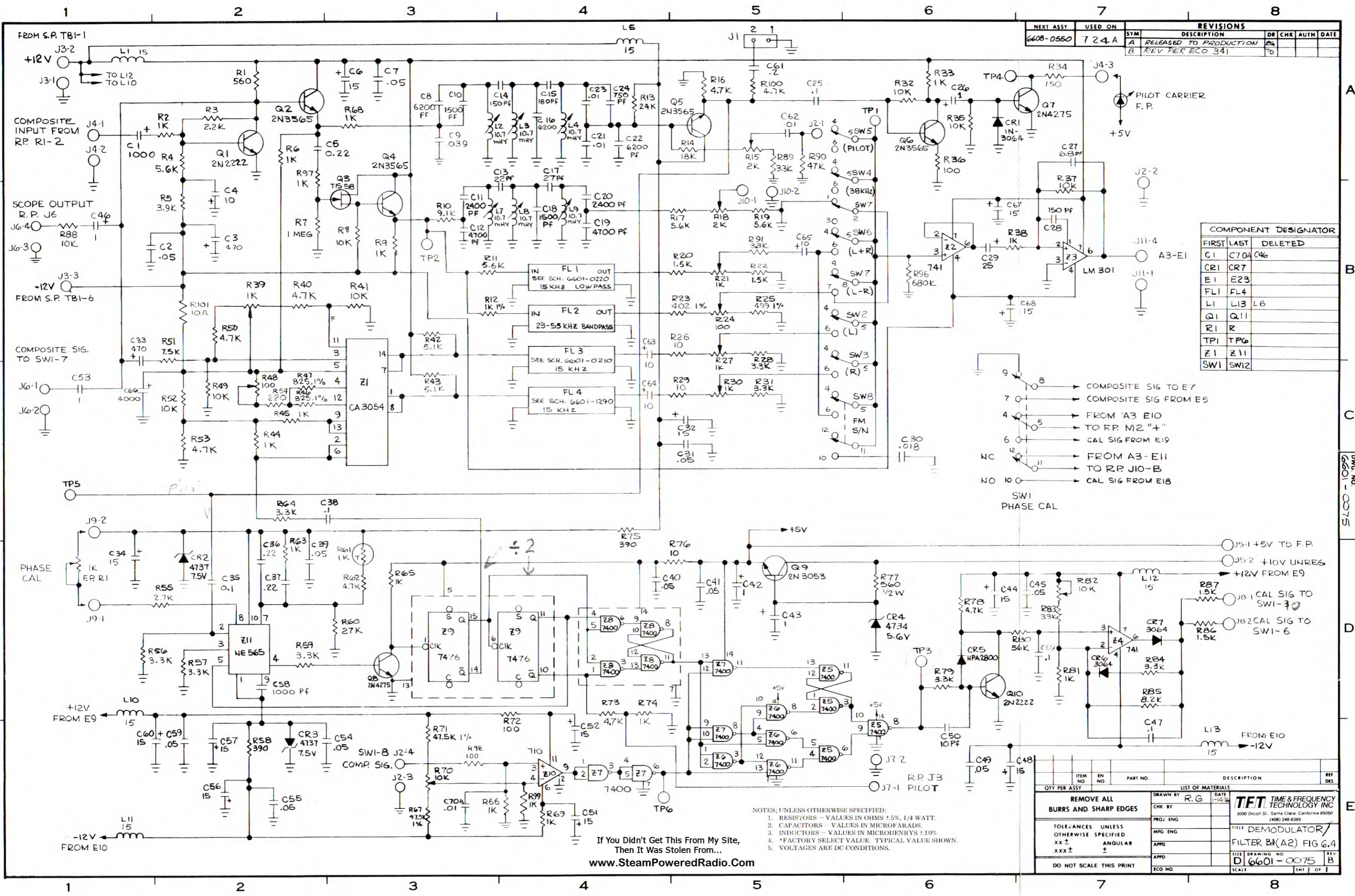

NEXT ASSY		USED ON		REVISIONS			
SYM	DESCRIPTION	DR	CHK	AUTH	DATE		
6608-0550	724A	A					
B	REV PER ECO 341	To					

COMPONENT DESIGNATOR		
FIRST	LAST	DELETED
C1	C70A	C46
CR1	CR7	
E1	E23	
FL1	FL4	
L1	L13	L6
Q1	Q11	
R1	R	
TP1	TP6	
Z1	Z11	
SW1	SW12	

- 8 → COMPOSITE SIG TO E7
  - 7 → COMPOSITE SIG FROM E5
  - 4 → FROM 'A3 E10 TO FP M2 '+'
  - 6 → CAL SIG FROM E19
  - NC → FROM A3-E11
  - NO 10 → CAL SIG FROM E18
- SW1 PHASE CAL

- NOTES: UNLESS OTHERWISE SPECIFIED:
- RESISTORS - VALUES IN OHMS ±5%, 1/4 WATT.
  - CAPACITORS - VALUES IN MICROFARADS.
  - INDUCTORS - VALUES IN MICROHENRYS ±10%
  - \*FACTORY SELECT VALUE. TYPICAL VALUE SHOWN.
  - VOLTAGES ARE DC CONDITIONS.

If You Didn't Get This From My Site,  
Then It Was Stolen From...  
[www.SteamPoweredRadio.Com](http://www.SteamPoweredRadio.Com)

QTY PER ASSY	ITEM NO	EN NO	PART NO	DESCRIPTION	REF DES

  

REMOVE ALL BURRS AND SHARP EDGES		LIST OF MATERIALS	
CHK BY	DATE	DRAWN BY	DATE
R.G	1-14-76		
PROJ ENG			
MFG ENG			
APPD			
APPD			
ECO NO			

**TFT** TIME & FREQUENCY TECHNOLOGY INC.  
3000 Olcott St. Santa Clara, California 95050  
(408) 245-6365

TITLE: DEMODULATOR/  
FILTER B1(A2) FIG 6.4

SIZE: DRAWING NO: D 6601-0075  
SCALE: SHI OF 1

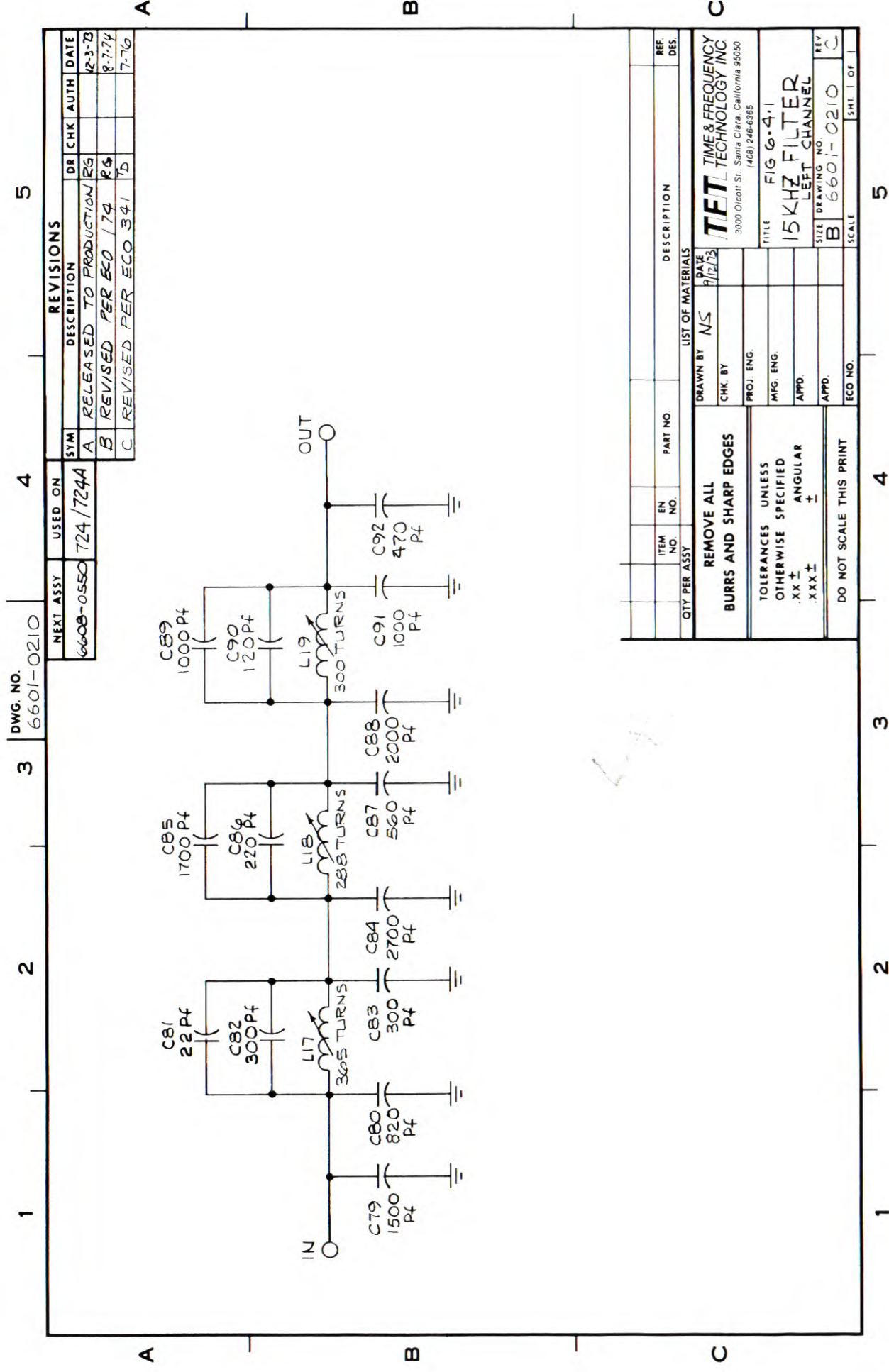

DWG. NO.  
6601-1290

NEXT ASSY		USED ON		REVISIONS				
SYM	DESCRIPTION	DR	CHK	AUTH	DATE			
66008-0550	724 / 724A	A			12-3-73			
B	REVISED PER ECO 179	R.G.			8-7-74			
C	REVISED PER ECO 341	T.D.			7-76			

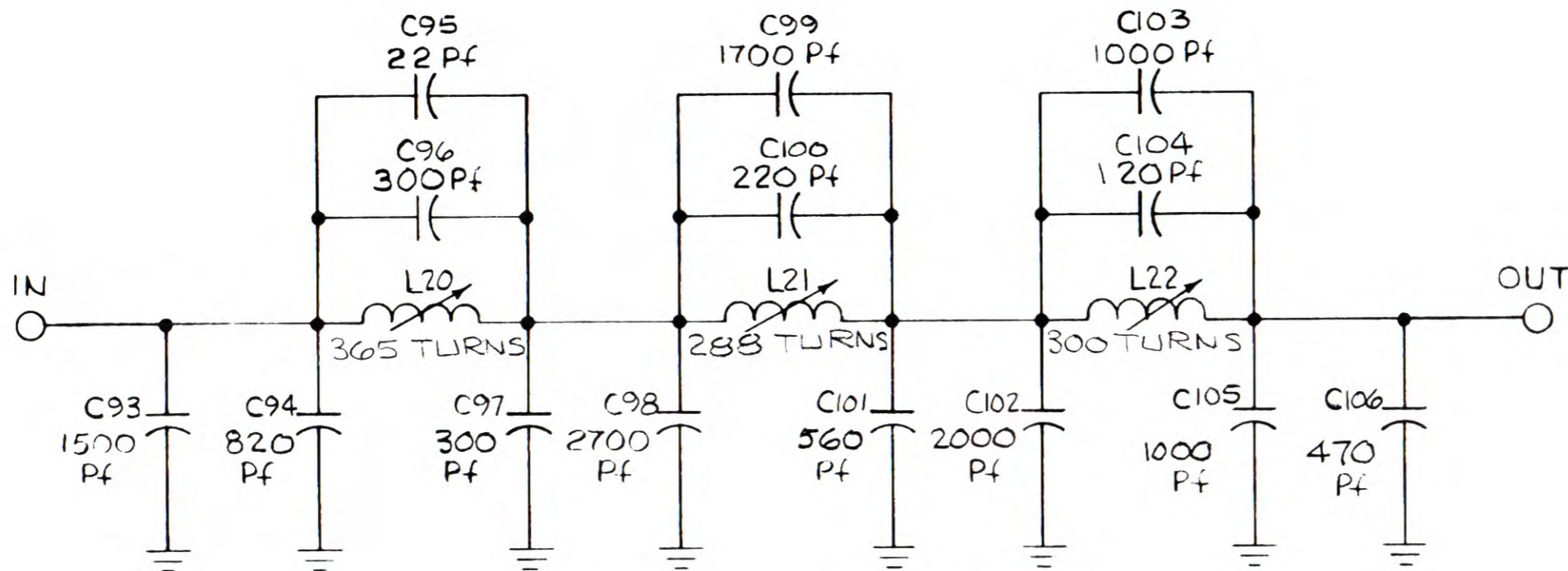

*2 more 201  
C621-0210  
R*

ITEM NO.	EN NO.	PART NO.	DESCRIPTION	REF. DES.
QTY PER ASSY				
LIST OF MATERIALS				
REMOVE ALL BURRS AND SHARP EDGES			DRAWN BY NS DATE 9/12/73	<b>TFT</b> TIME & FREQUENCY TECHNOLOGY INC. 3000 Olcott St., Santa Clara, California 95050 (408) 246-6365  TITLE FIG 6 <b>15KHZ FILTER</b> RIGHT CHANNEL  SIZE B DRAWING NO. 6601-1290 REV. C SCALE SHT. / OF 1
TOLERANCES UNLESS OTHERWISE SPECIFIED .xx ± ANGULAR .xxx ± ±			CHK. BY	
DO NOT SCALE THIS PRINT			PROJ. ENG.	
			MFG. ENG.	
			APPD.	
			APPD.	
			ECO NO.	

Model 724A

Power Supply PC Assy

Assembly # 6608-1070

Ckt. Ref.	Description	TFT Stock No.
C1	Cap Elect 1000 Mfd 15V	1010-0102
C2	Cap Elect 1000 Mfd 15V	1010-0102
C3	Cap Elect 500 Mfd 25V	1010-0511
C4	Cap Elect 500 Mfd 25V	1010-0511
C5	Cap Elect 15 Mfd 25V	1010-0150
C6	Cap Elect 15 Mfd 25V	1010-0150
CR1	Dio Rect 1N4001	1284-4002
CR2	Dio Rect 1N4001	1284-4002
CR3	Dio Rect 1N4001	1284-4002
CR4	Dio Rect 1N4001	1284-4002
J1	Plug, 3 Pin	2250-6003
J2	Plug 7 Pin Molex	2250-6007
R1	Res Car Comp 1/2W 5% 22	1066-0022
R2	Res Car Comp 1W 5% 100	1067-1525
R3	Res Car Comp 1/2W 5% 22	1066-0022
Z1	I/C MC7912	1100-7912
Z2	I/C Reg LM 342-12	1100-4212
	Heatsink Vertical Mount	2010-6030
	PC Board P.S. 724A	1600-1070

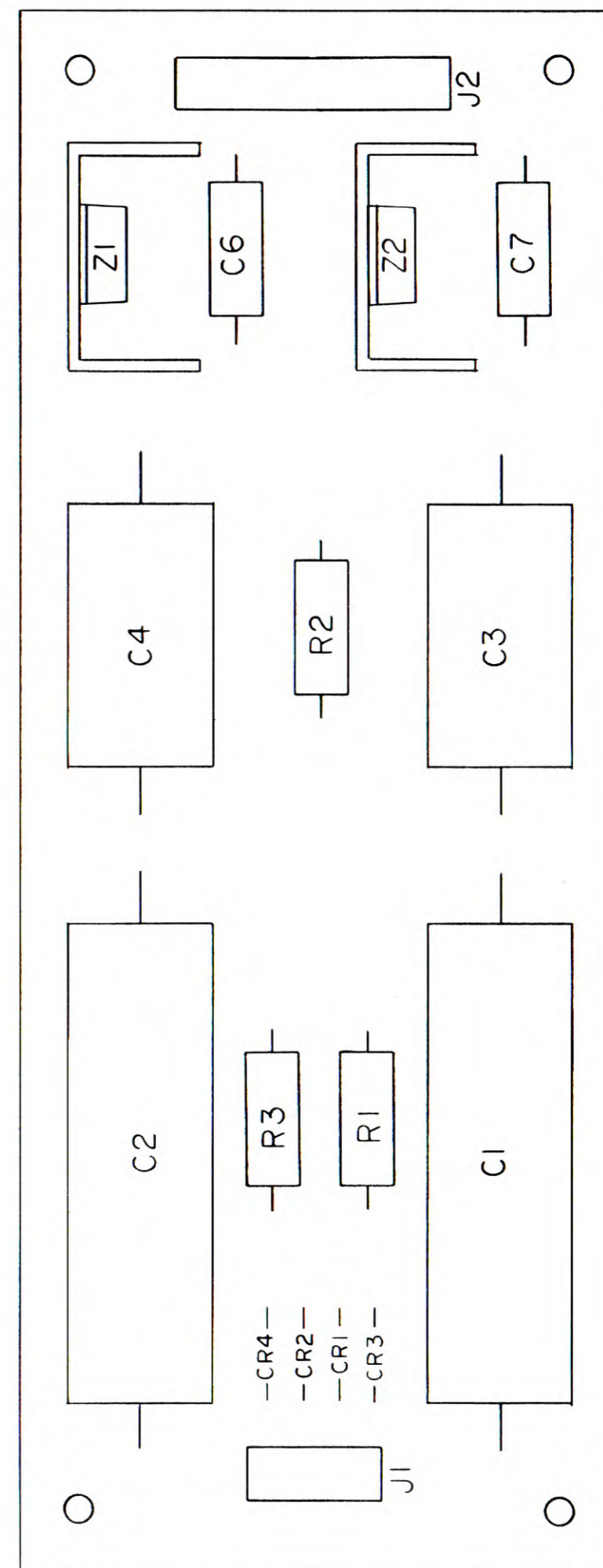

POWER SUPPLY 6608-1070



1

2

3

DWG. NO.  
6601-1560

4

5

NEXT ASSY		USED ON		REVISIONS					
6608-1070		724 A		SYM	DESCRIPTION	DR	CHK	AUTH	DATE
				B	REV PER ECO 341	TD			7-14-76

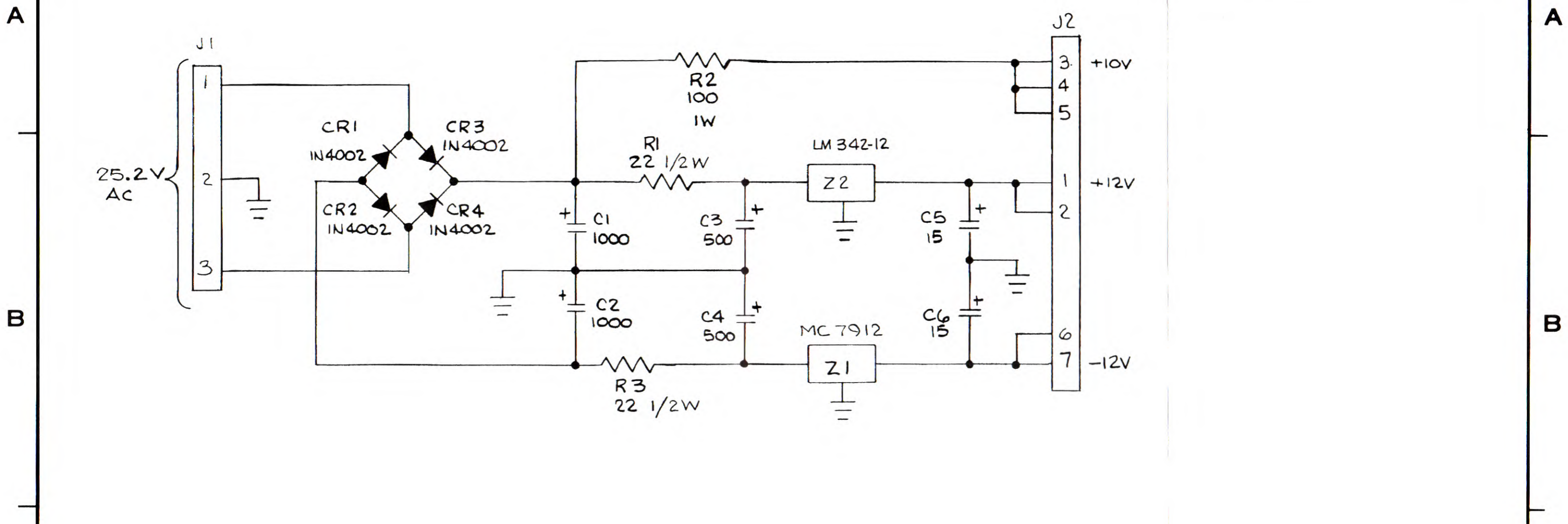

- NOTES; UNLESS OTHERWISE SPECIFIED:
1. RESISTORS - VALUES IN OHMS ±5%, 1/4 WATT.
  2. CAPACITORS - VALUES IN MICROFARADS.
  3. INDUCTORS - VALUES IN MICROHENRYS ±10%
  4. \*FACTORY SELECT VALUE. TYPICAL VALUE SHOWN.
  5. VOLTAGES ARE DC CONDITIONS.

If You Didn't Get This From My Site,  
Then It Was Stolen From...  
www.SteamPoweredRadio.Com

ITEM NO.	EN NO.	PART NO.	DESCRIPTION	REF. DES.
QTY PER ASSY      LIST OF MATERIALS				
<b>REMOVE ALL BURRS AND SHARP EDGES</b>			DRAWN BY	R.G
			DATE	1-9-76
TOLERANCES UNLESS OTHERWISE SPECIFIED .XX ±      ANGULAR .XXX ±      ±			CHK. BY	
			PROJ. ENG.	
DO NOT SCALE THIS PRINT			MFG. ENG.	
			APPD.	
			APPD.	
			ECO NO.	
			<b>TFT TIME &amp; FREQUENCY TECHNOLOGY INC.</b> 3000 Olcott St., Santa Clara, California 95050 (408) 246-6365	
			TITLE <b>POWER SUPPLY</b> FIGURE 6.5	
		SIZE	DRAWING NO.	REV.
		B	6601-1560	B
			SCALE	~      SHT. 1 OF 1

1

2

3

4

5

Model 724A

Front PNL Stereo MNTR

Assembly # 5102-0480

Ckt. Ref.	Description	TFT Stock No.
	Led HP 5082-4403 RED MTR Lighted Weston MTR Lighted Weston 724F Panel F PNL Ext 713, 720, 723, 732, 724 Screw FL HD 4-40X5/16 Bezel Weston 0271923 Fuse Clip Lamp Meter Name Plate, Logo 724	1285-4403 1400-4200 1400-4201 2000-0190 2001-0590 2104-0005 2140-0271 2250-2001 2300-7382 3001-0044

Model 724A

Chassis Assy 724A

Assembly # 5102-0490

Ckt. Ref.	Description	TFT Stock No.
	Cap Tan 10MFD 10%	1008-0100
	Res Var PL MT W/LKG 1K 1T	1070-1001
	I/C LM340T-12	1100-0340
	I/C MC7912	1100-7912
	Term Post #1456	1700-0003
	Term BLK 5 Pin	1700-0005
	Term Strip 6 Pos	1700-0006
	Term BLK 8 Pin	1700-0008
	Lug GND #10	1710-1010
	Lug GRD BNC (1)	1710-1200
	Switch Tog SPDT	1800-1035
	SHT MTL 724 Chassis	2001-0450
	Screw 4-40X 1/4	2104-0001
	Screw	2106-0009
	Nut Kep 4-40	2111-0001
	6-32 Nut Kep	2111-0004
	MT. Tab, Nylon	2140-0006
	Conn,RF BNG CH. MT	2200-7935

MODEL 724A  
MANUAL REVISION LEVEL B  
EFFECTIVE SERIAL NO 240-2

### IMPORTANT MANUAL CHANGES

A power transformer, line cord, fuse, and associated wiring have been added to the Model 724A so that it is no longer dependent on the Model 763 for its power. The following drawings are affected, and new copies are attached; Wiring diagram Figure 6.2, Front and rear panel drawings figures 3-1 and 3-2, and Figure 2-2. Other portions of the manual affected are as follows.

#### 1.2 Specifications

##### Power Requirements

117 VAC +10%, 15 Watts max.

#### 2.3 Installation Procedures

b. Connect the power cord to a 117VAC power source.

#### 3.2.2 Rear Panel

9. Power Cord and fuse

Main power to the Model 724A. If unit is wired for 230V power cord will be so labeled. Fuse should be reduced to 1/8 Amp S.B. when used with 230VAC.