

INSTRUCTION MANUAL

inspiled on 30th April 5/13/94

40-2214 C 001

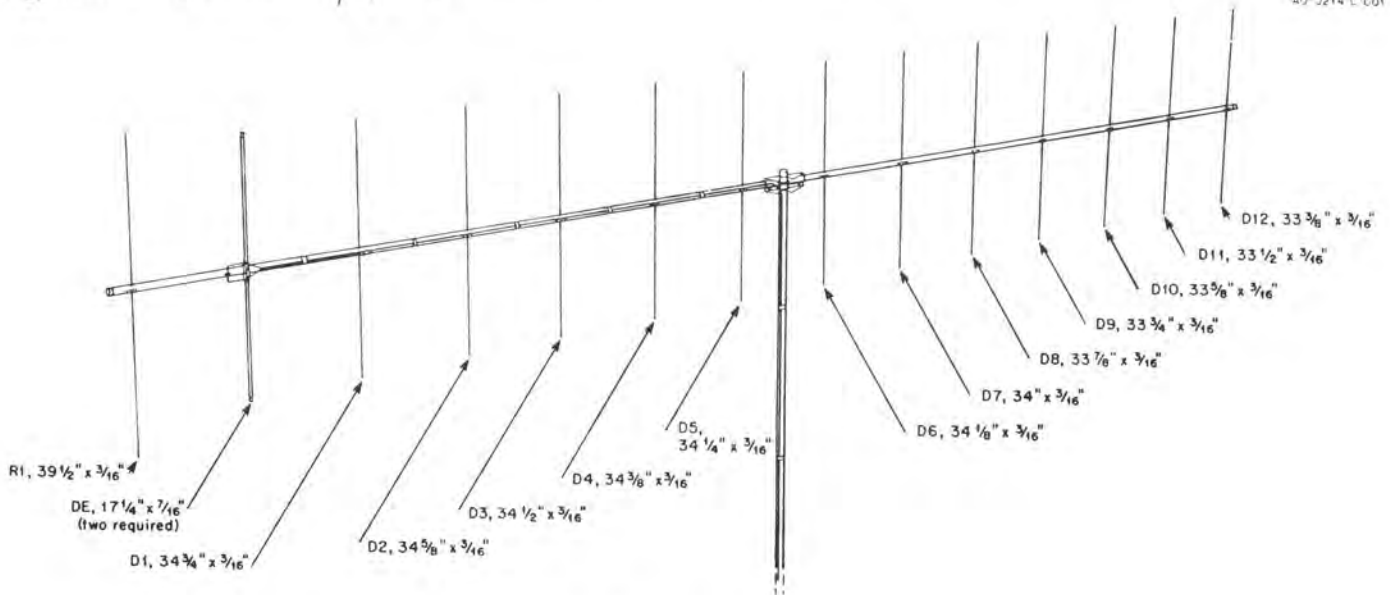

Figure 1
Overall View

GENERAL DESCRIPTION

This antenna is a 14-element, close-spaced, two meter beam. It features high forward gain associated with a narrow beam width. It has an excellent front-to-back ratio and is especially suited for DX contacts where maximum gain and a narrow beam width is required.

The 214FM antenna now features stainless steel hardware for all electrical and most mechanical connections, and a NEW boom-to-mast bracket that will fit mast diameters up to 2 1/16 inches.

SPECIFICATIONS

Mechanical

Boom Length 15'6" (4.72 m)
Longest Element 39 1/2" (1003 mm)
Turning Radius (maximum) 95" (2.41 m)
Wind Survival 80 mph (129 kmph)

Mast Diameter 1 5/8" to 2 1/16" O.D.
(41 mm to 52 mm)
Boom Diameter 1 1/4" O.D. (32 mm)
Wind Area 1.65 sq. ft. (vertical),
1.28 sq. ft. (horizontal)
Net Weight 5.5 pounds (2.5 kg)

Electrical

Gain 15.2 dBi (13.0 dBd)
Front-to-Back Ratio 20 dB
Maximum SWR 2:1
Band Width 4 MHz
Maximum Power 250 watts continuous,
500 watts P.E.P.
Impedance 50 ohms (with balun)
Half-Power Beam Width 35° (vertical,
horizontal polarization)
Broadside Stacking Distance 12' max.,
6'10" min.

INSTRUCTION MANUAL

insp. on 30th April 5/13/94

49-2214 C-001

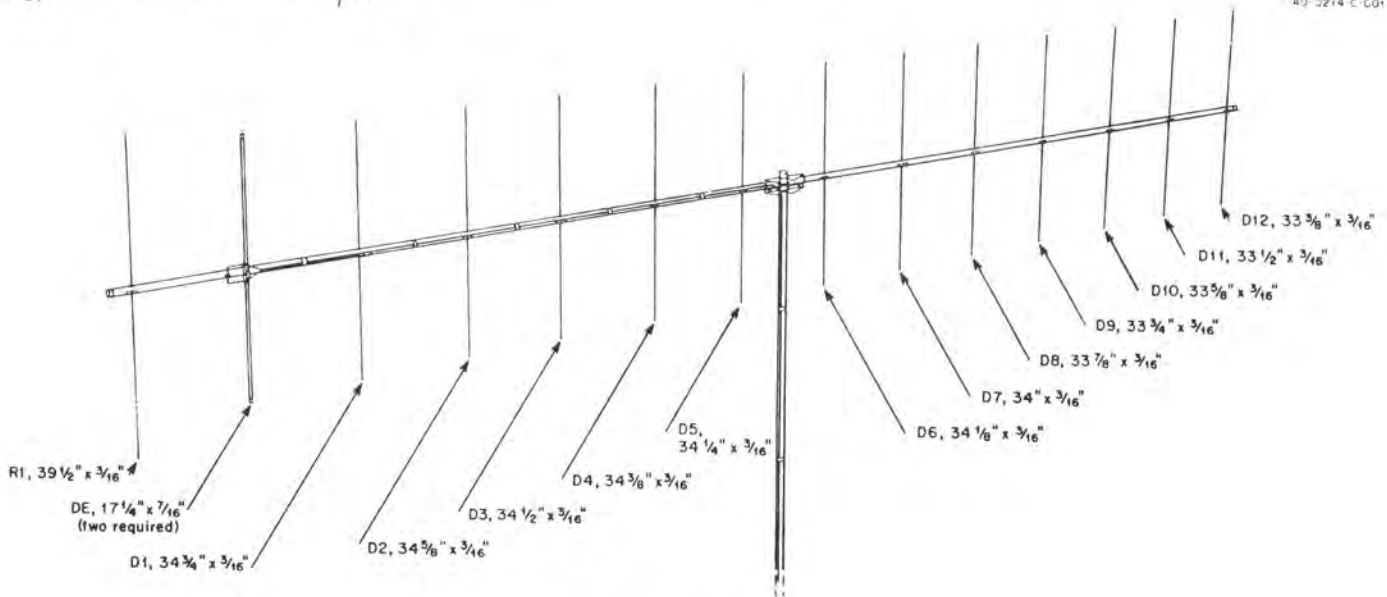

Figure 1
Overall View

GENERAL DESCRIPTION

This antenna is a 14-element, close-spaced, two meter beam. It features high forward gain associated with a narrow beam width. It has an excellent front-to-back ratio and is especially suited for DX contacts where maximum gain and a narrow beam width is required.

The 214FM antenna now features stainless steel hardware for all electrical and most mechanical connections, and a NEW boom-to-mast bracket that will fit mast diameters up to 2 1/16 inches.

SPECIFICATIONS

Mechanical

Boom Length 15'6" (4.72 m)
Longest Element 39 1/2" (1003 mm)
Turning Radius (maximum) 95" (2.41 m)
Wind Survival 80 mph (129 kmph)

Mast Diameter 1 5/8" to 2 1/16" O.D.
(41 mm to 52 mm)
Boom Diameter 1 1/4" O.D. (32 mm)
Wind Area 1.65 sq. ft. (vertical),
1.28 sq. ft. (horizontal)
Net Weight 5.5 pounds (2.5 kg)

Electrical

Gain 15.2 dBi (13.0 dBd)
Front-to-Back Ratio 20 dB
Maximum SWR 2:1
Band Width 4 MHz
Maximum Power 250 watts continuous,
500 watts P.E.P.
Impedance 50 ohms (with balun)
Half-Power Beam Width 35° (vertical,
horizontal polarization)
Broadside Stacking Distance 12' max.,
6'10" min.

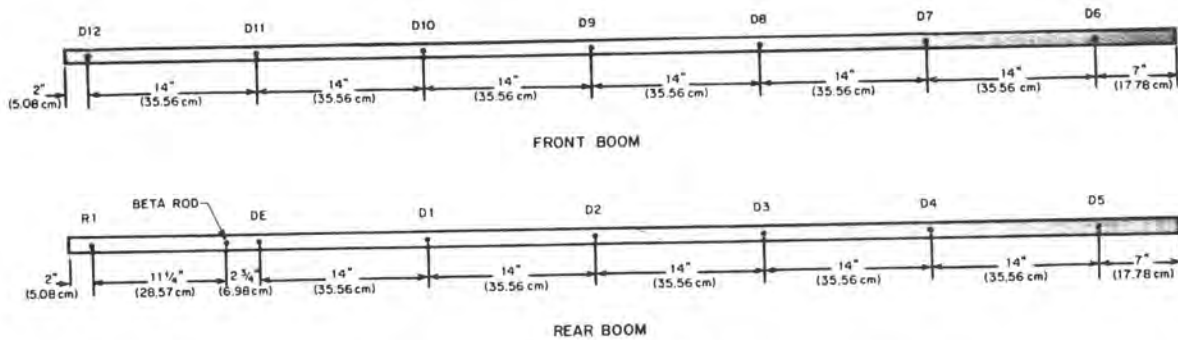

Figure 2
Element Spacing on Booms

SWR AND FEEDLINE

The 214FM antenna has an input impedance of 200 ohms. The supplied balun matches the input to 50 ohms. If you are using transmission line with a characteristics impedance other than 50 ohms or 200 ohms, a matching device must be made. Refer to any current Amateur Handbook for information on constructing a matching device.

TUNING

NOTE: The Driven and Parasitic Elements are adjusted independently in the following manner:

Parasitic Elements: This antenna is pretuned for maximum gain and best radiation pattern at 146 MHz. This setting will give optimum performance over the entire 144-148 MHz band.

If you wish to optimize the antenna for a frequency higher than 146 MHz, cut $\frac{1}{4}$ " off of the total element lengths for each MHz higher than 146.

Driven Element: SWR can be lowered to less than 1.2:1 at a desired frequency by carefully trimming the driven element. Keep the element symmetrical by cutting the same amount from each side. Typical SWR curves are shown in Figure 3A and a cutting chart is shown in Figure 3B. Each installation is slightly different, so cut the driven element for the lower SWR at your particular location. Measure the SWR as close to the antenna as you can for accurate results.

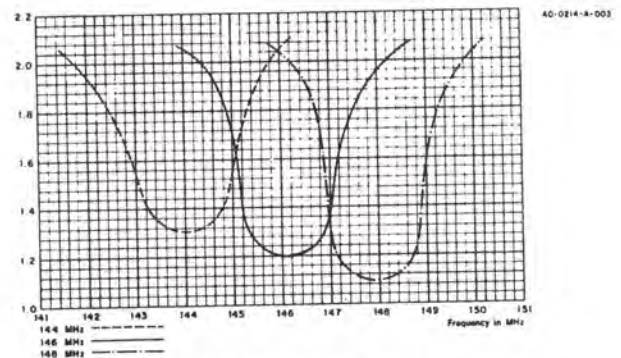

Figure 3A
VSWR for Horizontal Polarization Only

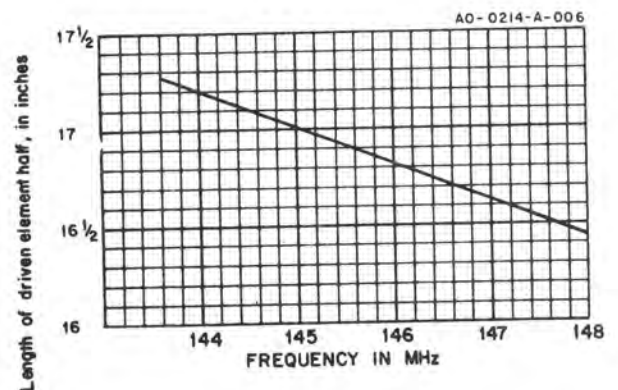

Figure 3B
Driven Element Cutting Chart

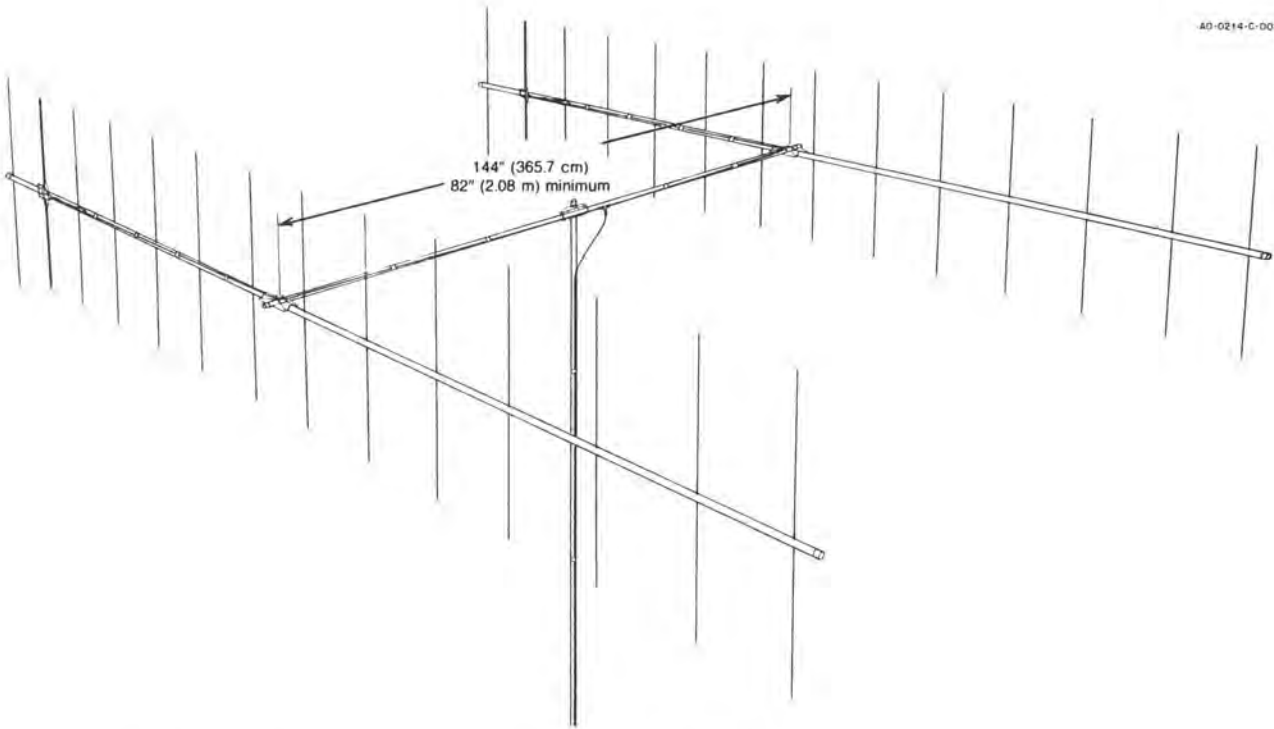

Figure 4
Vertically Polarized Broadside Stacking Configuration for FM Operation

STACKING

This antenna can be easily stacked for approximately 3 dB more gain each time the number of yagi is doubled. Refer to Figure 4 for stacking and phasing harness cutting information.

The two phasing lines coming from the two antennas to the "T" connector can be any odd multiple of one-quarter wavelength in the 75-ohm transmission line. See Figure 5.

NOTE: When phasing two antennas, the Driven Element halves that are connected directly to the phasing lines should be on the same side of the array.

The feedline impedance is for 50-ohm coax (RG-213/u). For detailed information on stacking more than two yagis, please consult any current Amateur Handbook.

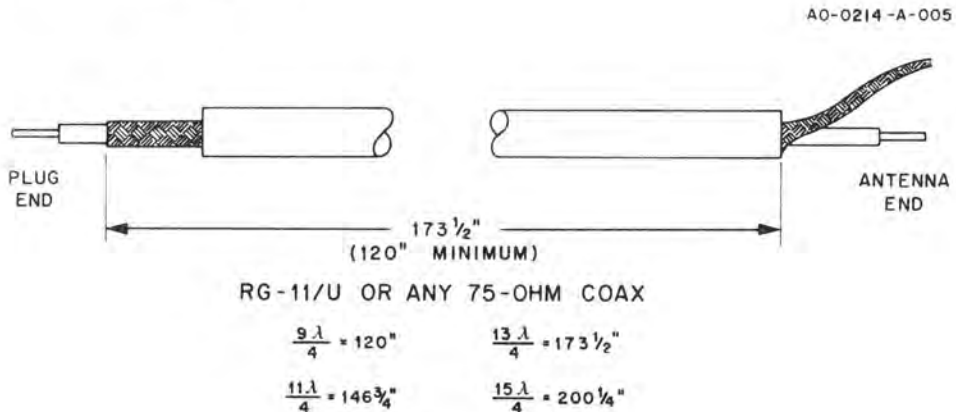

Figure 5
Coaxial Cable Length for Phasing

INSTALLATION

This antenna fits a 2" O.D. mast. A 2" O.D. galvanized pipe is recommended for a sturdy mast.

Mount the antenna in the clear. Surrounding objects—particularly power lines and other objects of considerable mass or length—are detrimental to the performance of the antenna.

WARNING

Do not allow any part of the antenna to touch power lines. This could cause severe burns or fatal injuries.

When mounting the 214FM with an HF beam antenna on the same mast, the 214FM should be on top. If the 214FM is to be vertically polarized, separation of the two antennas should be at least 2 feet. If the 214FM is to be horizontally polarized, separation should be at least 6 feet.

The mast, if metallic, should never be run completely through the plane of the elements. Slightly reduced performance will be noticed if a vertically polarized 214FM is mounted at the top of a metallic mast as shown in Figure 1. Horizontally polarized mounting will not be affected. For optimum performance with a vertically polarized 214FM, a wooden mast should be used, and the coax routed past the reflector then dropped to the mast.

The antenna can be mounted either vertically or horizontally for FM or SSB/CW operation respectively. Circular polarization can be obtained by using two yagis. For information about which polarization to use, consult local Amateurs who use the frequencies you desire.

STEP-BY-STEP ASSEMBLY

Remove the parts from the carton and check them against the Parts List and the illustrations.

Select the boom-to-mast backup plate (Item No. 6), the boom-to-mast clamp (Item No. 5) and the four (4) $\frac{1}{4}$ "-20 x $\frac{3}{4}$ " bolts, $\frac{1}{4}$ " lockwashers and nuts (Item Nos. 32, 33 & 34).

Place the boom-to-mast clamp on the boom as shown in Figure 6. The front and rear boom sections should meet in the middle of the boom-to-mast clamp. Use the $\frac{1}{4}$ "-20 x $\frac{3}{4}$ " bolts in the outside holes. Leave the inside holes for the two (2) U-bolts, which will be used later for mounting the mast. Select either the vertical or horizontal mounting position. Adjust the boom accordingly before tightening the bolts securely.

Select $\frac{3}{16}$ " x $39\frac{1}{2}$ " R1 aluminum tubing (Item No. 7). Use a pencil to place a mark at the center of the tubing ($19\frac{3}{4}$ " from either end). Place two more marks $\frac{5}{8}$ " from each side of the center mark.

Place a #10-24 x $1\frac{1}{2}$ " eyebolt (Item No. 27) into the R1 slot as shown in Figure 6, Detail A. Slide the R1 through the holes and the eyebolt until the outer two marks on the R1 are visible on each side of the boom. Slip on an aluminum half washer (Item No. 23), a lockwasher (Item No. 30) and a #10 nut (Item No. 31). Tighten it just enough to hold the rod securely. **DO NOT OVERTIGHTEN.**

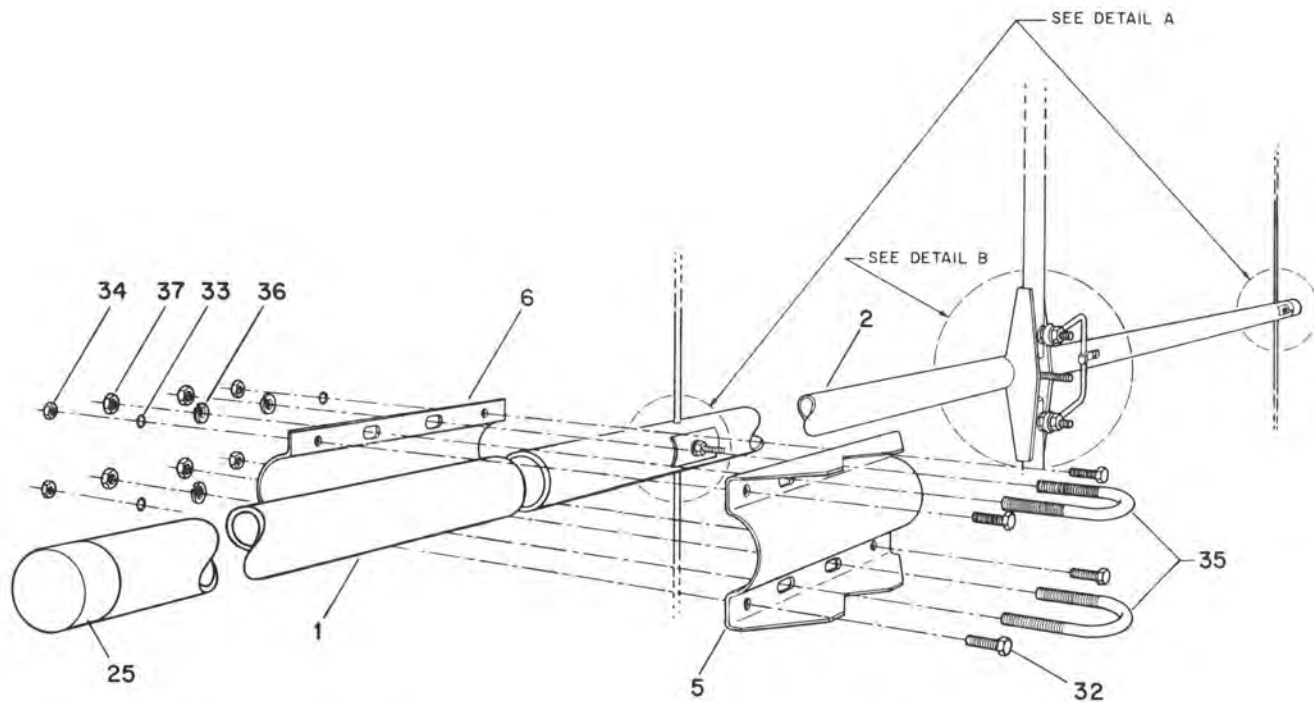

Item No.	Description
1	Boom, Rear, 1 1/4" x 93"
2	Boom, Front, 1 1/4" x 93"
5	Clamp, Boom-to-Mast
6	Backup Plate, Boom-to-Mast
25	Capplug, 1 1/4", black
32	Bolt, hex head, 1/4"-20 x 3/4"

Item No.	Description
33	Lockwasher, internal, 1/4"
34	Nut, hex, 1/4"-20
35	U-Bolt, 5/16"-18 x 3 5/8"
36	Lockwasher, split, 5/16"
37	Nut, hex, 5/16"-18

Figure 6
Boom-to-Mast Clamp Assembly

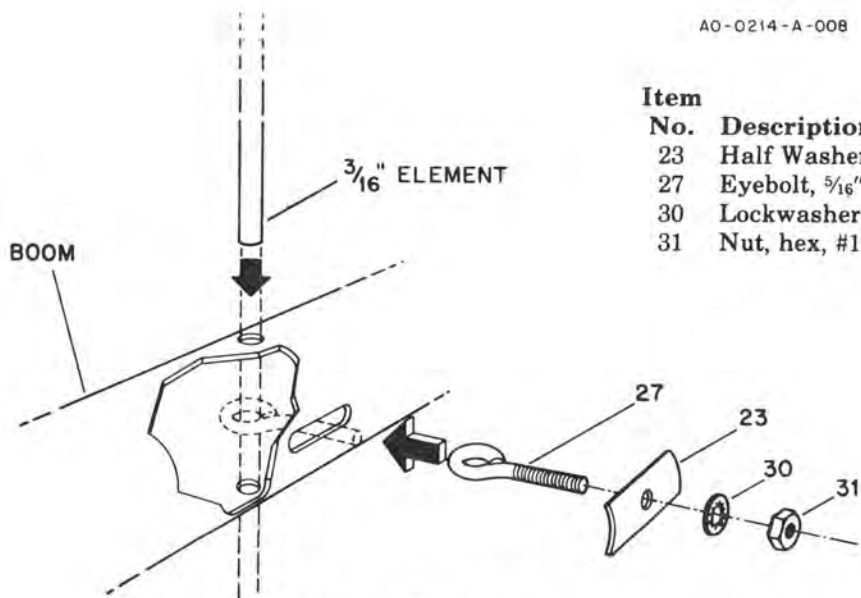

AO-0214-A-008

Item No.	Description
23	Half Washer, aluminum
27	Eyebolt, 5/16", #10-24 x 1 1/2"
30	Lockwasher, internal, #10
31	Nut, hex, #10-24

Figure 6 – Detail A
Element Assembly

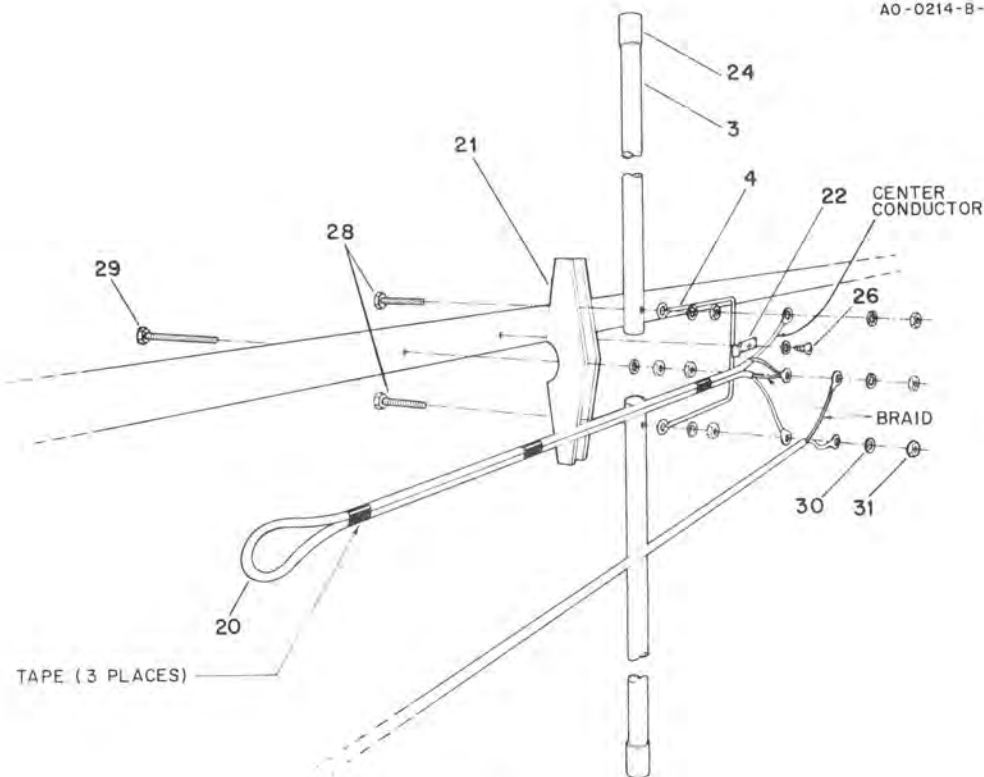

Item No.	Description	Item No.	Description
3	Driven Element, $\frac{7}{16}$ " x $17\frac{1}{4}$ "	26	Screw, pan head, #10 x $\frac{3}{8}$ ", Type A
4	Beta Rod, $2\frac{1}{2}$ "	28	Bolt, hex head, #10-24 x $1\frac{1}{2}$ "
20	Balun Assembly	29	Bolt, hex head, #10-24 x $2\frac{1}{2}$ "
21	Insulator (Driven Element-to-Boom)	30	Lockwasher, internal, #10
22	Beta Clip	31	Nut, hex, #10-24
24	Caplug, $\frac{7}{16}$ ", with hole, black		

**Figure 6 – Detail B
Driven Element Assembly**

Select the element-to-boom insulator (Item No. 21), two sections of the $\frac{7}{16}$ " x $17\frac{1}{4}$ " Driven Element (DE) (Item No. 3) and the beta rod (Item No. 4). See Figure 6, Detail B.

NOTE: If 50 ohm coaxial cable is used to feed the antenna, select the supplied balun at this time.

Use the #10-24 x $2\frac{1}{2}$ " bolt (Item No. 29) to fasten the element-to-boom insulator to the boom. Refer to Figure 6, Detail B.

Use the two (2) #10-24 x $1\frac{1}{2}$ " bolts (Item No. 28) to assemble the Driven Element as shown in Figure 6, Detail B. Pay particular attention to

the connections of the beta rod, balun and feedline.

Waterproof the coax connection with Coax-Seal® or some similar substance. Install caplugs on the ends of the boom and the Driven Element.

Use the #10 x $\frac{3}{8}$ " screw (Item No. 26) to fasten the beta rod shorting clip (Item No. 22) over the beta rod as shown in Figure 6, Detail B.

Select the following rods: D1 (34³/₄" long, Item No. 8), D2 (34⁵/₈" long, Item No. 9), D3 (34¹/₂" long, Item No. 10), D4 (34³/₈" long, Item No. 11), D5 (34¹/₄" long, Item No. 12), D6 (34¹/₈" long, Item No. 13), D7 (34" long, Item No. 14), D8 (33⁷/₈" long, Item No. 15), D9 (33³/₄" long, Item No. 16), D10 (33⁵/₈" long, Item No. 17), D11 (33¹/₂" long, Item No. 18), and D12 (33³/₈" long, Item No. 19). Mark the center point on each rod, then make two more marks ⁵/₈" on either side of the center mark. Secure the

elements to the boom as shown in Figure 6 and Detail B. Be sure they are oriented as shown.

Slip the two U-bolts (Item No. 35) into the boom-to-mast bracket and fasten it to the mast securely. Tape the coax feedline and balun to the boom and to the mast. Be sure to insulate any connections from the boom or the mast. This completes your installation.

FOR OUR OVERSEAS CUSTOMERS: The United States uses American units of measurement. Please see the information below for assistance in identify the hardware and components supplied with the product.

CONVERTING AMERICAN MEASUREMENTS TO METRIC

Use this scale to identify lengths of bolts, diameters of tubes, etc. The American inch (1") and foot (1') can be converted to centimeters in this way:

$$1 \text{ inch (1")} = 2.54 \text{ cm}$$

$$1 \text{ foot (1')} = 30.48 \text{ cm}$$

$$\text{Example: } 42" \times 2.54 = 106.7 \text{ cm}$$



PARTS LIST

Item No.	Part No.	Description	Qty
1	170390	Boom, Rear, 1¼" x 93"	1
2	170387	Boom, Front, 1¼" x 93"	1
3	175157	Driven Element, 7/16" x 17¼"	2
4	170389	Beta Rod, 2 ½"	1
5	385142-1	Clamp, Boom-to-Mast	1
6	385144-1	Backup Plate, Boom-to-Mast	1
7	160037	Tubing, R1, aluminum, 3/16" x 39½"	1
8	160024	Tubing, D1, aluminum, 3/16" x 34¾"	1
9	160025	Tubing, D2, aluminum, 3/16" x 34⅝"	1
10	160026	Tubing, D3, aluminum, 3/16" x 34½"	1
11	160027	Tubing, D4, aluminum, 3/16" x 34⅜"	1
12	160028	Tubing, D5, aluminum, 3/16" x 34¼"	1
13	160029	Tubing, D6, aluminum, 3/16" x 34⅛"	1
14	160030	Tubing, D7, aluminum, 3/16" x 34"	1
15	160031	Tubing, D8, aluminum, 3/16" x 33⅞"	1
16	160032	Tubing, D9, aluminum, 3/16" x 33¾"	1
17	160033	Tubing, D10, aluminum, 3/16" x 33⅝"	1
18	160034	Tubing, D11, aluminum, 3/16" x 33½"	1
19	160035	Tubing, D12, aluminum, 3/16" x 33⅜"	1
20	871704	Balun Assembly	1
21	465420	Insulator (Driven Element-to-Boom)	1
	872072-1	Parts Pack 214S-1, Stainless Steel	1
22	163266	Beta Clip	1
23	170376	Half Washer, aluminum	13
24	475639	Caplug, 7/16", with hole, black	2
25	455630	Caplug, 1¼", black	2
26	510670	Screw, pan head, #10 x 3/8", Type A	1
27	540065	Eyebolt, 5/16", #10-24 x 1½"	13
28	500159	Bolt, hex head, #10-24 x 1½"	2
29	500164	Bolt, hex head, #10-24 x 2½"	1
30	565697	Lockwasher, internal, #10	21
31	554071	Nut, hex, #10-24	20
32	505266	Bolt, hex head, ¼"-20 x ¾"	4
33	562961	Lockwasher, internal, ¼"	5
34	554099	Nut, hex, ¼"-20	4
35	540067	U-bolt, 5/16"-18 x 3⅝"	2
36	564792	Lockwasher, split, 5/16"	4
37	555747	Nut, hex, 5/16"-18	4

PRINTED IN U.S.A.
 Copyright©1989 by Telex
 TELEX COMMUNICATIONS, INC.
 All rights reserved.
 16 MAY 1989