



528 Voice Processor
Operating Manual

Revision 1.0 1 January, 1987

Symetrix

4211 24th Avenue West
Seattle, Washington 98199, USA
Telephone (206) 282-2555
Telex 703282

Signal processing at its best

If You Didn't Get This From My Site,
Then It Was Stolen From...

www.SteamPoweredRadio.Com



528 Voice Processor
Operating Manual
Revision 1.0 1 January, 1987

Symetrix Inc.
4211 24th Ave. West
Seattle WA 98199

Telephone (206)282-2555
Telex 703282 SYMETRIX UD

©1987 Symetrix, Inc.

FOREWORD

This manual contains all the information you need to operate the 528 Voice Processor. There are seven chapters. The individual sections of each chapter are labeled first with the chapter number, then with the section number. For example, the first section of the first chapter is labeled 1.1, and the third section of the fourth chapter is labeled 4.3, and so on. Use the numbers referenced in the Table of Contents to quickly locate the information you need.

IF YOU'RE GOING TO JUMP RIGHT IN AND START USING THE 528 WITHOUT READING THE MANUAL, JUST TAKE A MINUTE TO RUN THROUGH SECTION 3 - FAST FIRST TIME SETUP.

Several different notation conventions are used to indicate various facets of the 528's features:

CAPS

indicate a marked feature on the 528, like the bypass switch, or the INPUT connector.

**Boldface and
italics**

are used for emphasis. Bold type carries more weight than italic type.

Some of the text in this manual is set apart by one of the headings Note, or Caution:

NOTES convey useful information that's included to make certain functions more obvious, and to supply extra information about processes, techniques, connectors etc.

CAUTION indicates a potential danger to the 528 or associated equipment. An example of a CAUTION can be found below.

CAUTION

Save the original box, packing material, and purchase receipt. If ever it's necessary to ship your unit it must be packaged in its original box to prevent damage, and the receipt may be required as proof of purchase for warranty repairs. (See Section 7.)

Table of Contents

1. Introduction	1
1.2 Microphone Preamplifier.....	1
1.3 Phantom Power.....	1
1.4 Downward Expander, Compressor/Limiter	2
1.5 Defining Dynamic Range.....	3
1.6 Dynamic Range as a Specification.....	3
1.7 Dynamic Range of Sounds and Signals	3
1.8 Why Dynamic Range Processors are Necessary	4
1.9 Compressors are to Expanders as Limiters are to Gates.....	4
1.10 The Threshold Concept.....	4
1.11 The VCA - Voltage Controlled Amplifier.....	5
1.12 Linear vs. Downward Expanders	5
1.13 How Expanders Increase Usable Dynamic Range.....	5
1.14 Sidechain Processing	5
1.15 De-esser.....	6
1.16 Parametric Equalizer/Notch Filter	7
2. Using the 528	8
2.1 Getting Started.....	8
2.2 A Word About the Controls.....	8
2.3 Block Diagram.....	9
2.4 Input/Output Connections	10
2.5 Patching/Sidechain Connections	11
2.6 Mic Preamp Controls	12
2.7 De-esser Controls.....	12
2.8 Dynamic Range Processor Controls.....	13
2.9 Parametric Equalizer/Notch Filter Controls	13
2.10 Output Gain Control, Metering	13
2.11 Installation	14
3. Fast First Time Setup	15
3.1 Connections	15
3.2 Mic Preamp Setup.....	16
3.3 De-esser Setup	16
3.4 Dynamic Range Processor Setup	16
3.5 Parametric EQ/Notch Filter Setup.....	16
3.6 Output Settings	16
3.7 Meter Readings	16
4. Applications	17
4.1 Broadcast Applications	17
4.2 Using the Parametric EQ/Notch Filter.....	17
4.2.1 Beware Distortion and Noise.....	17
4.2.2 Know What You Are Listening To	18
4.2.3 Use Wide Peaks, Narrow Notches	18
4.2.4 Tuning the EQ/Notch Filter.....	18
4.2.5 Parametric EQ/Notch Filter Examples.....	18
4.3 Announce Mics - Compressing, Limiting, Expanding.....	21
4.4 Using the De-esser.....	23
4.5 Cleaning Up News Feeds.....	25
4.6 Increasing Gain Before Feedback.....	25
4.7 Parametric EQ in the Sidechain.....	26

4.8	Using Sidechain EQ to Enhance Expander Action	26
4.9	Using Reverb or Effects.....	27
4.10	Vocal Processing - Recording and Reinforcement.....	27
4.11	Adding Dynamics, or "Punch".....	28
4.12	High Level Stage Monitors - Dynamic Processing.....	28
5.	528 Specifications.....	29
6.	Troubleshooting Guide.....	30
6.1	Troubleshooting Table	30
7.	Service Information/Schematics.....	31
7.1	In Warranty Service.....	31
7.2	Out-of-Warranty Service	31
7.3	Schematic Diagrams	31
7.3.1	201750B - PCB Component Placement.....	32
7.3.2	191750B - Input Stages	33
7.3.3	191750B - De-esser	34
7.3.4	191750B - Compressor/Expander	35
7.3.5	191750B - Parametric EQ/Notch Filter.....	36
7.3.6	191750B - Output Driver, Display, Power Supply.....	37
7.3.7	191752A - Output Level Display	38
APPENDIX A - Using Electronically Balanced Inputs and Outputs.....		39
APPENDIX B - Notes on the 528-01 (Option 1 Transformer Coupled Output).....		40
WARRANTY STATEMENT		41

1. Microphone Signal Processors

1.1 Introduction

The 528 Voice Processor contains five functions needed for microphone signal processing: mic preamp (with phantom power), de-esser, downward expander, compressor/limiter, and parametric equalizer. The 528's "normal" signal chain includes all five functions, but the de-esser, the dynamics processor (expander/compressor/limiter), and the parametric EQ/notch filter may be individually bypassed with front panel switches.

In addition, the versatility of the 528 is greatly enhanced by its patching capabilities. Each section is brought out to its own set of normalled rear panel terminations, so any signal routing possibility is provided for, and patch bay installations are supported.

1.2 Microphone Preamplifier

The ultra low noise, low distortion mic preamp provides a direct-coupled balanced input, for optimum transient response and phase coherency. Its positive going and negative going slew rates are symmetrical, ensuring sonic integrity. The mic preamp's balanced input gain may be adjusted with the front panel gain trim control, allowing it to handle very high signal levels -- up to -3dBV without overload.

1.3 Phantom Power

All condenser microphones require some kind of electrical power for operation. This power may be supplied to the mic by internal batteries, an external power supply that's connected to the microphone by a special cable, or through the microphone cable by phantom or "T" System powering.

The 528 provides phantom powering for condenser microphones. The rear panel PHANTOM POWER switch applies +48VDC to pins 2 and 3 at the mic input XLR connector. Phantom power is so named because it is "invisible" to audio signals, even though the microphone cable carries both direct current (DC) phantom power, and alternating current (AC) audio signals. Specifically, the term phantom power means a positive DC voltage applied to the microphone via both audio leads, usually pins 2 and 3 of a 3-pin XLR type connector. This voltage is applied through current limiting resistors, which also serve to isolate the audio leads from one another.

The phantom power technique uses the mic cable to deliver the power required by the microphone, eliminating the need for an additional external power supply or internal batteries. In this situation +48VDC is applied equally to both sides of a floating balanced circuit, so no current flows through the microphone's transformer, or through the microphone element itself. However, if the circuit is unbalanced, current will flow. As a result, unbalanced mics can never be used with phantom power.

Phantom powering is not to be confused with "T" System powering, sometimes called modulation lead or AB powering. "T" System powering applies power to only one audio lead, using the other as power ground. *Phantom powering and "T" System powering are not compatible without special adapters.*

It is often said that the sound of some dynamic microphones is affected by phantom power, and that ribbon mics cannot be plugged into an input that is phantom powered. For the most part these are myths that grew out of difficulties that occurred as a result of some other problem in the mic circuit:

1. When XLR connectors are mated there is no guarantee that both pins 2 and 3 will make contact at exactly the same time. It is possible that a damaging current could flow through the mic for a brief moment under these conditions. However, this is a connector problem, not a problem with the mic itself, or phantom power in particular.
2. If the mic's output transformer has developed leakage, the microphone may become noisy (crackling, sputtering or even humming) when phantom power is turned on. The leakage, not the power, is the problem. The available solutions are to turn off the phantom power, put a 1:1 transformer between the mic and the input, or get the mic repaired.

CAUTION

Do not use phantom power before consulting the microphone manufacturer's literature. Many condenser microphones have non-standard power requirements, and may be damaged by +48 volt powering. Unbalanced microphones must not be used with phantom powering.

1.4 Downward Expander, Compressor/Limiter

The 528 Voice Processor utilizes Symetrix' program controlled interactive dynamic range processing technique to combine the best attributes of both compressor/limiters, and expanders. "Program controlled" means the 528's dynamic range processor section analyzes incoming signals, then adjusts its attack and release times to match the transient characteristics of those signals.

Levels are kept in check by the compressor/limiter, which responds quickly to transients, and gently to normal speech level changes. The downward expander's operation is the inverse of the comp/limiter, so it prevents "pumping" and "breathing" even when high ratio compression is necessary. Because the compressor/limiter and the downward expander are interactive, the 528 always responds appropriately, while providing automatic control over a wide range of input levels.

Strictly speaking, the terms compressor and limiter refer to two different devices. However, the two are often combined into a single device called a compressor/limiter. Compressor/limiters usually perform as either a compressor or a limiter, but not both at once. Functionally, a compressor/limiter is a device that lets the user define, or predetermine, the maximum level of an audio signal.

Expanders and gates are the functional opposites of compressors and limiters. Compressors continuously reduce the dynamic range of signals that are *above* threshold, while expanders continuously increase the dynamic range of signals that are *below* threshold. Limiters can be thought of as very high ratio compressors, and gates can be thought of as very high ratio expanders.

1.5 Defining Dynamic Range

To begin a discussion of dynamic range processors it's necessary to have a working definition of dynamic range. The term is really self-descriptive, but has two distinctly different uses:

1. To describe the actual range of signal fluctuations that are going through the equipment, and
2. To define the maximum allowable range of signal fluctuations that can be put through the equipment.

The usual unit of measure for audio signals is the decibel (dB).

1.6 Dynamic Range as a Specification

The maximum usable range of operation for a particular circuit or piece of gear is the distance in dB between the noise floor and the maximum output level. In this context, dynamic range is used as an equipment specification.

Noise floor is defined as the lower limit of a circuit's operating level, and is a function of its self-generated electrical noise. Very noisy circuits have a high noise floor, quiet circuits have a low noise floor. The maximum output level is the upper limit of the operating level, and is the level at which clipping begins. To put levels in perspective they must be referenced to some nominal operating level, like 0dBm. That's why noise specs are stated as minus something.

In the case of the 528, noise is referred to the input, and stated as equivalent input noise (EIN). The noise specification is given this way because the gain of the 528's input stage is variable, so the actual signal-to-noise performance of the unit becomes a function of how much gain is used in the preamp. To find the signal-to-noise ratio at 0dBm output, subtract the preamp gain from the EIN.

Since maximum output level is usually greater than 0dBm, it's stated as plus something. The 528's maximum output level is +24dBm, which is 24dB above 0dBm. The difference between the noise floor and the onset of clipping is the dynamic range. To find the 528's dynamic range with 50dB preamp gain, subtract -87 from +24. 111dB is the dynamic range.

1.7 Dynamic Range of Sounds and Signals

The other definition of dynamic range describes actual level changes, or the range over which signals fluctuate. The signals under discussion here are electrical representations of sounds, so it follows that sound has dynamic range. The dynamic range of the human voice, from a whisper to a shout, is well over 100dB. So a microphone will convert the sound pressure of a the voice going from a whisper to a shout into an electrical output signal with a dynamic range of well over 100dB.

1.8 Why Dynamic Range Processors are Necessary

For signals to stay below distortion and above noise, their actual dynamic range must be kept within the specified dynamic range of the circuits through which those signals flow. Unfortunately, the actual dynamic range of real world signals often exceeds the available dynamic range of even the best equipment.

For example, the dynamic range of the best analog tape recorders is around 80dB, while digital recorders top out at around 96dB. As good as these machines are, there's still not quite enough room for very wide dynamic range signals. In order to maintain a 60dB signal-to-noise ratio (to keep the signals 60dB above the noise floor), the dynamic range of signals stored on the analog tape machine would have to be restricted by 20dB, while the digital recorder would be restricted by 36dB.

A compressor or limiter is often used to reduce dynamic range by setting an upper limit on the larger signals. However, in some cases it's better to put processing to work on the lower end of the dynamic range than on the upper end. In other words, instead of reducing the amount of change at the upper end of the dynamic range with a compressor or limiter, increasing the amount of change at the lower end of the dynamic range with an expander or gate.

1.9 Compressors are to Expanders as Limiters are to Gates

Compressors reduce the dynamic range of their output whenever the input signal is above threshold, while expanders increase the dynamic range of their output whenever the input signal is below threshold.

Compressors, limiters, expanders, and gates increase or decrease signal levels by some ratio. Compressors usually have an adjustable ratio, that is, the ratio of the input level to the output level can be changed by the user. A compressor operating with a 2:1 ratio would allow only a 1dB increase in output level for every 2dB increase in input level.

Limiters usually have a non-adjustable ratio that is very high (greater than 10:1). At 10:1, the limiter allows only a 1dB increase in the output level for every 10dB increase in the input level. Limiters can be thought of as high ratio, high threshold compressors. They are intended to "stay out of the way" until the level goes above threshold. However, above threshold their action is very definite.

1.10 The Threshold Concept

The threshold is the level at which a dynamic range processor's activity begins. In operation, the dynamic range processor's sensing circuitry constantly "looks at" the incoming signal and compares it to a reference level, which is called the threshold level. In practice that reference level is set by the operator with the threshold control. Remember, compressors and limiters respond when signals at the input are above threshold, while expanders and gates respond only when signals at the input are lower than the defined threshold.

1.11 The VCA - Voltage Controlled Amplifier

The action of a dynamic range processor is determined by one of the amplifier circuits inside the unit whose gain is controlled by a DC voltage. That part of the circuit is called a voltage controlled amplifier, or VCA. Inside the 528 a separate buffered audio signal is sent to a group of circuits that comprise the detector. The detector circuits turn the AC audio signal into a DC control voltage, which is sent to the VCA under the direction of the front panel controls.

1.12 Linear vs. Downward Expanders

Expander operation is easily misunderstood unless it's remembered that what's being expanded is the dynamics, or changes, of signals passing through the circuit. Expanders come in two very different types: linear, and downward.

Linear expanders increase the dynamic range of all signals, no matter what their actual level. The linear expander simply makes all changes greater by some ratio, which is sometimes user adjustable. Linear expanders can cause distortion, because clipping occurs when signals just below maximum output level are expanded.

For instance, an unprocessed signal 3dB below clipping that goes up 2dB won't distort, because it's still 1dB below maximum. But if that same signal is passed through an expander operating at a 1:2 ratio, the same 2dB change at the expander's input would become a 4dB change at its output. However, that signal would be 1dB over maximum, causing distortion. Linear expanders must be used with care, because very few systems have enough headroom to handle the upward dynamic range increase they produce .

The kind of processor most commonly called an expander is really a downward expander, because it only affects signals below threshold. This gives the operator control over the expander's activities, allowing it to be used to expand the usable dynamic range of the system without running out of headroom.

1.13 How Expanders Increase Usable Dynamic Range

The lower limit restriction of a system is the noise floor, which is usually well below the 528's lowest expander threshold (-60dBm). It's important to keep in mind that while the signal levels may change greatly, the noise usually doesn't change very much. The action of the expander increases the dynamics of all signals below threshold that *do* change. This action increases the apparent loudness of those changing signals, while decreasing the apparent loudness of the noise.

For example, an expander operating at a ratio of 1:2 will cause a signal that falls 10dB at its input to fall 20dB at its output. The downward action of the expander reduces the noise floor by the same ratio applied to the signal. Since the relationship between the signal and the noise stays the same, the noise is reduced 20dB by the action of expander, which is responding to a 10dB drop in the signal with its 1:2 ratio.

1.14 Sidechain Processing

The sidechain is a patch point in the control circuit of a dynamic range processor, which provides access to the part of the circuitry that tells the VCA what to do. The 528's

sidechain is routed through a pair of rear panel barrier strip terminations that allow the control signal to be processed outside the unit (see Section 2.4 for specific hookup information).

Look at the block diagram in section 2.3. Notice the SIDECHAIN terminations that come from the comp/limit/expand section. They allow access to the control circuit that is taken from the audio signal at the dynamic range processor's input. This control signal is derived from, but kept totally separate from, the audio signal path. That means the control signal can be processed outside the 528 without actually processing the signal that's going through the VCA (the audio signal itself). This presents some very interesting possibilities for changing or improving the operation of the dynamic range processor.

The best use of the sidechain is to make the action of the 528's comp/limiter/expander frequency dependent, that is, to make it respond more (or less) to certain frequencies. Because the audio signal and the control signal remain completely separate (even while the control circuit tells the VCA whether to turn the gain up or down), you can equalize the sidechain without changing the EQ in the main audio path.

Removing unwanted frequencies from the control signal before it actually reaches the VCA prevents those frequencies from being used to create gain changes. And perhaps most importantly, this is accomplished without actually equalizing the signal being processed through the 528. Applications utilizing the sidechain may be found in Section 4.

1.15 De-esser

A de-esser is another type of dynamic range controller that's specially designed to regulate high frequency content. The technique was originally developed for motion picture dialogue recording, when it was discovered that speech sounded more natural and pleasing when the accentuation of sibilants was reduced. By sensing and limiting certain selected frequencies, the de-esser is intended to provide more specific control over some of the higher frequency vocal sounds that tend to become over emphasized.

Many sibilant vocal sounds like "s," "sh," and "t" are very difficult to reproduce electronically, because they contain a large percentage of very high frequency harmonics. But because these sounds are so essential to the intelligibility of speech, they cannot be simply removed with equalization. In fact, to help maintain articulation many sound engineers boost the higher frequencies of the vocal spectrum (3kHz to 8kHz), and/or use microphones with "presence curves." However, in certain individuals sibilant sounds are already over accentuated, and any kind of high frequency boost only exacerbates the situation.

The 528's de-esser controls excessive sibilant and fricative vocal sounds, which can often be as much as 12dB louder than the rest of the spectrum. It's activity is similar to a frequency conscious comp/limiter (with an equalizer boosting the high frequencies in its sidechain). Unlike a comp/limiter however, it operates only on the frequencies selected. And unlike an equalizer the de-esser can reduce the offending sounds without sacrificing intelligibility, because it operates dynamically. It removes only sounds that are disproportionately loud, and only those that fall within the operator-selected control range.

De-essers usually include controls that allow the operator to determine which frequencies are controlled, and how much those frequencies are actually attenuated. The 528's de-

esser controls are FREQUENCY, which is variable from 800Hz to 8kHz, and RANGE, which may be set from 0dB to 20dB. In other words, the 528's de-esser will attenuate selected frequencies between 800Hz and 8kHz as much as 20dB.

1.16 Parametric Equalizer/Notch Filter

The parametric EQ/notch filter provides both creative and corrective frequency shaping - it can be used to create a more pleasing sound, and to correct amplitude response problems. It's designed to provide an asymmetrical +15dB/-30dB boost/cut response to allow any of its three bands to perform as equalizers or highly selective notch filters.

The term "parametric" simply refers to the fact that the operating parameters of the equalizer may be altered. Those parameters that are user adjustable are (1) center frequency (or f_c , expressed in Hz), (2) bandwidth (sometimes called "Q," or selectivity, expressed in octaves), and (3) the amount of cut or boost (expressed in dB).

1. Center Frequency is defined as the frequency (in Hz) at the middle of the bell shaped response curve formed by a filter.
2. Bandwidth is the width of the bell shaped curve, measured between its -3dB points. The measure of bandwidth in audio equalizers is usually given in octaves or parts of an octave.
3. Cut or Boost is given in dB, at the center frequency.

"When all else fails, read the directions."

2.1 Getting Started

This section of your manual will give you all the control and switch settings you need to operate the 528. Brief descriptions of the control functions are provided here, while Section 4 includes examples of how the 528 is used, with thorough explanations of the operation of each of the 528's processors.

IF YOU'RE GOING TO JUMP RIGHT IN AND START USING THE 528 WITHOUT READING THE MANUAL, JUST TAKE A MINUTE TO RUN THROUGH SECTION 3 - FAST FIRST TIME SETUP. REMEMBER, THIS ONLY NEEDS TO BE DONE ONCE TO BECOME FAMILIAR WITH THE 528'S CONTROLS - AFTER THAT IT'S EASY.

2.2 A Word About the Controls

With its variety of functions and associated controls, the 528 can be used effectively in a large number of situations. However, the level of performance you are able to extract from the 528 depends entirely on your understanding of the relationship between the individual functions and controls.

2.3 Block Diagram

The functional block diagram in Figure 2.1 illustrates the signal flow into, inside of, and out of the 528. Notice that the audio signal is routed through patch points between each of the major sections, and that the sidechain of the dynamic range processor section is available. These connections are all made on the rear panel barrier strips TB1 and TB2.

NOTE

THE UNIT WILL NOT WORK WITHOUT A COMPLETE CIRCUIT PATH THROUGH ALL REAR PANEL PATCHING TERMINATIONS. Patching and sidechain connections provide an output/input loop in the circuitry. For signals to flow from the 528's mic or line input to its output, the connection through these terminations must remain intact. Therefore, the patching and sidechain terminations are "normalled" by shorting straps installed at the factory. All terminal pairs that must be normalled are indicated by "U" shaped chassis markings over the barrier strips. The shorting straps may be removed when signals are routed elsewhere for processing, or when individual sections of the 528 are used for signals not originated at the 528's input.

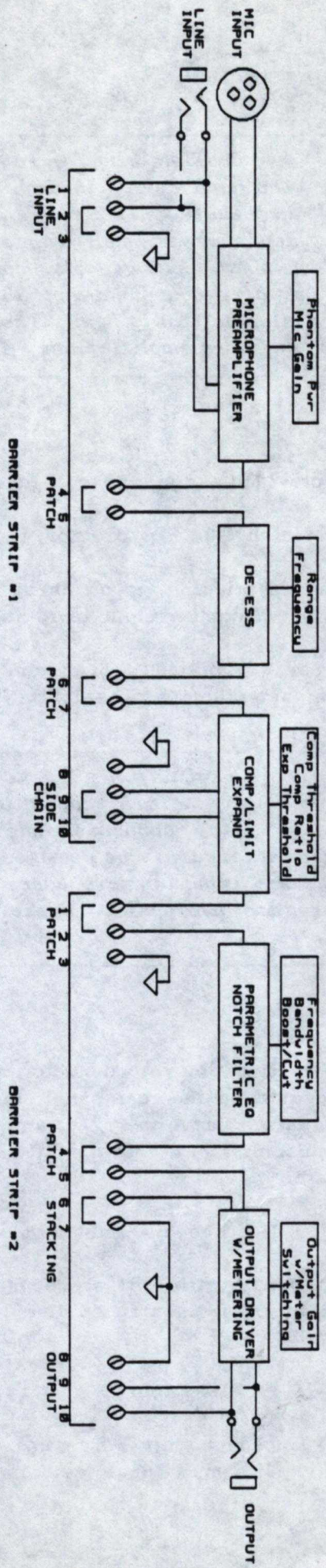

2.4 Input/Output Connections

CAUTION

When the 528 is used as an input device in any system that includes power amplifiers and loudspeakers, do not plug into either the mic or line inputs while the system's power amplifiers are "on." The 528 can contribute substantial gain to input signals, and very large low frequency transients may be produced at the 528's output when input connections are made while the unit is "on." These transient signals will not damage the 528, but when amplified, may damage loudspeakers.

MIC INPUT

A 3-pin XLR connector is provided for microphone level input signals.

Pin 1 = ground Pin 2 = high (+) Pin 3 = low (-)

Input impedance is balanced bridging (to match all low impedance professional microphones). Maximum input level is -3dBV.

+48VDC phantom power may be applied through pins 2 and 3 of the MIC INPUT connector by depressing the rear panel PHANTOM POWER switch.

CAUTION

Do not use phantom power before consulting the microphone manufacturer's literature. Many condenser microphones have non-standard power requirements, and may be damaged by +48 volt phantom powering. In addition, some dynamic microphones may be damaged by phantom powering. For more information, please refer to Section 1.3 Phantom Power (on page 1).

LINE INPUT

A 1/4" 3-conductor TRS (Tip-Ring-Sleeve) connector, which is paralleled by barrier strip terminals. Located on the rear panel, the TRS connector accepts balanced or unbalanced signals. Use either 2-conductor (mono type) or 3-conductor (stereo type) connectors. As shown in the block diagram in Figure 2.1, the TRS connections are:

Tip = high (+) Ring = low (-) Sleeve = ground (shield).

Terminals 1, 2 and 3 on barrier strip TB1 are connected inparallel with the 1/4" TRS connector. Balanced or unbalanced line level input signals may be connected here as well.

#1 = high (+) #2 = low (-) #3 = ground

The balanced LINE INPUT impedance is 46.3k ohms. Unbalanced input impedance is 23.1k ohms. Maximum input level is +18dBV.

STACKING INPUT

A pair of terminations on barrier strip TB2 for signals from another 528 Voice Processor (or any other line level device). This input allows two 528's to be operated through a single output. To stack two 528's, connect the EQ OUT patch from one 528 to the STACKING INPUT on the other 528. (The OUTPUT GAIN controls remain separately active, as "submasters.")

#7 = signal #6 = ground

The STACKING INPUT impedance is >10k ohms, maximum input level is +18dBm.

OUTPUT

A 1/4" 2-conductor (mono type) TS (Tip-Sleeve) connector, which is in parallel with the barrier strip output terminals #8 and 10. Located on the rear panel, the the 1/4" connector delivers unbalanced low impedance output signals.

Tip = signal Sleeve = ground (shield).

Terminals 8, 9, and 10 on barrier strip TB2 deliver balanced output signals. The connections are:

#8 = ground #9 = low (-) #10 = high (+)

Output impedance is 51 ohms, balanced or unbalanced. Minimum load impedance is 600 ohms. Maximum output level is +24dBm balanced, +18dBm unbalanced.

CAUTION

When the output is operated in an unbalanced configuration DO NOT ground the unused leg. Doing so will unnecessarily load the output driver, resulting in increased distortion and possible damage. See Appendix A - Using Electronically Balanced Inputs and Outputs.

2.5 Patching/Sidechain Connections

Output/Input patching connections are provided on the rear panel barrier strips TB1 and TB2, as shown in the drawing below. All terminations are unbalanced.

PATCHING

Output impedances are all <100 ohms, minimum load impedance for all patching outputs is 600 ohms. Maximum output level is +18dBm.

Input impedances are all >20k ohms. Maximum input level is +18dBV.

SIDECHAIN

The SIDECHAIN connections provide access to the dynamic range processor's control circuit, via terminals 8, 9 and 10 on barrier strip TB1.

Output impedance of the SIDECHAIN is <100 ohms, minimum load impedance is 600 ohms. Maximum output level is +18 dBm. Input impedance is >20k ohms, maximum input level is +18dBV.

NOTE

Patching and sidechain connections provide an output/input loop in the circuitry. For signals to flow from the 528's input to output, the connection through these terminations must remain intact. Therefore, the patching and sidechain terminations are "normalled" by shorting straps installed at the factory. All terminal pairs that must be normalled are indicated by "U" shaped chassis markings over the barrier strips. The shorting straps may be removed when signals are routed elsewhere for processing, or when individual sections of the 528 are used for signals not originated at the 528's input.

2.6 Mic Preamp Controls

PREAMP GAIN

Sets the gain of the microphone preamplifier, from 10 (3dB) at its most counterclockwise rotation, to 50dB at its most clockwise rotation.

CLIP

Illuminates when preamp output levels reach +16dBm.

PHANTOM POWER

On the rear panel near the line output jack, this switch turns on +48VDC phantom power for condenser microphones, applied via pins 2 and 3 of the XLR input connector.

2.7 De-esser Controls

DE-ESS FREQUENCY

Selects the frequency range to be placed under the control of the de-esser.

DE-ESS RANGE

Determines how much the selected frequencies will be attenuated. At 0dB the de-esser is essentially out of the circuit, while at 20dB all signals within the selected frequency range will be attenuated 20dB.

BYPASS

Enables/disables the de-esser.

2.8 Dynamic Range Processor Controls

EXPAND THRESHOLD

Sets the level below which the downward expander's activity begins.

COMPRESS THRESHOLD

Sets the level above which the compressor/limiters' activity begins.

COMPRESSION RATIO

Sets the compressor/limiter's ratio from 1.4:1 to 20:1.

BYPASS

Enables/disables the compressor/limiter/expander.

2.9 Parametric Equalizer/Notch Filter Controls

CUT/BOOST

Adjusts the cut or boost from -30dB to +15dB.

BANDWIDTH

Sets the selectivity ("Q") of the equalizer, and therefore the amount of the spectrum affected by the CUT/BOOST control. Calibrated in octaves, from .05 to 3.3 (see Section 1.12, Parametric Equalizer/Notch Filter).

FREQUENCY

Determines which frequency lies at the center of the bell-shaped curve that encompasses the particular frequencies affected by this band of the equalizer. Calibrated in Hz, the LO, "MID" and "HI" sections may be overlapped.

EQ BYPASS

Switches the parametric equalizer/notch filter into or out of the circuit path.

2.10 Output Gain Control, Metering

OUTPUT GAIN

Sets the overall gain of the 528 from a minimum of -15dB, to 0dB (unity) at top dead center, to a maximum of +15dB.

OUTPUT LEVEL

Indicates the unit's output level in volume units (VU). 0VU = 1.23 volts across 600 ohms (+4dBm).

CLIP

Illuminates when output levels are within 3dB of the onset of clipping.

GAIN REDUCTION

Indicates the gain reduction provided by either the dynamic range processor section (compressor/limiter/expander), or by the de-esser section.

COMPRESS/DE-ESS

Switches the GAIN REDUCTION meter to read the gain change at the dynamic range processor's VCA, or the de-esser's VCA.

2.11 Installation

The unit is designed for mounting in a standard 19" rack, and requires only 1 rack space (1-3/4"). The 528's INPUTs, OUTPUTs and SIDECHAIN connectors should be wired to a patch bay (like the Symetrix Patch 32) for ease of operation. A suggested arrangement is shown in Figure 2.3. The patching output/input connections and the SIDECHAIN output/input connection must remain intact when not used. **When the unit is wired into a patch bay, these connections must be normalled.**

CAUTION

Do not mount the 528 near high power devices like amplifiers and power supplies. When the unit is rack mounted, take care to keep it as far from hum fields as possible. Like all devices designed to provide high gain for low level signals, the 528's microphone preamp is sensitive to induced hum.

3. Fast First Time Setup

Follow this sequence to get the 528 up and running quickly - the connections and settings are intended to get signal into and out of the 528, and to create obvious activity in each processor section. The drawings at the end of this section illustrate the setup. **FOR QUICK SETUP, DO NOT DEPRESS ANY OF THE BYPASS SWITCHES.**

CAUTION

When the 528 is used as an input device in any system that includes power amplifiers and loudspeakers, do not plug into either the mic or line inputs while the system's power amplifiers are "on." The 528 can contribute substantial gain to input signals, and very large low frequency transients may be produced at the 528's output when input connections are made while the unit is "on." These transient signals will not damage the 528, but when amplified, may damage loudspeakers.

3.1 Connections

MIC INPUT

Plug the microphone's male XLR into this connector.

LINE INPUT

Use either the 1/4" TRS input, or terminals 1, 2 and 3 on barrier strip TB1, to feed line level signals to the 528.

OUTPUT

Use either the 1/4" TS connector for an unbalanced output, or terminals 8, 9 and 10 on barrier strip TB2 for a balanced output, to feed signals to the input of the following device.

3.2 Mic Preamp Setup

PREAMP GAIN

For *dynamic* mics, set the slot at "12 o'clock" (approx. 35dB gain).

For *condenser* mics, set the slot at "9 o'clock" (approx. 25dB gain).

PHANTOM POWER (rear panel)

For *dynamic* microphones, do not depress this switch.

For *condenser* microphones that require +48VDC phantom powering, depress this switch (See Section 1.3 Phantom Power).

CAUTION

Do not use phantom power before consulting the microphone manufacturer's literature. Some condenser microphones have non-standard power requirements, and may be damaged by +48 volt phantom powering. In addition, some dynamic microphones may be damaged by phantom powering. For more information, please refer to Section 1.3 - Phantom Power (on page 1).

3.3 De-esser Setup

DE-ESS 1kHz
FREQUENCY

DE-ESS..... 10dB
RANGE

3.4 Dynamic Range Processor Setup

EXPAND -20
THRESHOLD

COMPRESS -20
THRESHOLD

COMPRESS.....10
RATIO

3.5 Parametric EQ/Notch Filter Setup

EQ LO

CUT/BOOST..... -30
BANDWIDTH..... .72
FREQUENCY..... 60

EQ MID

CUT/BOOST +6
BANDWIDTH72
FREQUENCY 2.5k

EQ HI

CUT/BOOST.....+6
BANDWIDTH......72
FREQUENCY..... 8.8k

3.6 Output Settings

OUTPUT 0
GAIN

3.7 Meter Readings

The upper LED OUTPUT LEVEL (VU) meter reads output level, in volume units. This meter is active in all operating conditions. The lower LED GAIN REDUCTION meter may be switched to read the activity of either the de-esser, or the compressor/limiter/expander. This meter will not be lighted unless the 528 is attenuating signals.

4. 528 Applications

The 528 Voice Processor was designed to make the same kind of specialized processing that's applied to voice-overs and vocal tracks in recording studios available for use in broadcasting, paging, public address and sound reinforcement. In a recording studio, four or five separate pieces of equipment are usually patched together to obtain the kind of processing provided by the 528.

For the highest level of versatility, we recommend making the output/input patching and sidechain connections available by wiring the unit to a patch bay as shown in Figure 2.3. This allows access to the individual sections of the 528, provides for easy use of the sidechain, and allows the processing order to be changed at will (to place the parametric in the sidechain, for instance).

The following discussions illustrate some of the more useful applications for the 528. Because of its versatility, combinations of the applications described here will normally be used.

4.1 Broadcast Applications

With the 528, a variety of common problems can be corrected, and overall sound quality can be greatly improved. In addition to its "normal" use with announce mics, there are several more specialized uses for the Voice Processor. This section provides general operating guidelines for the various parts of the 528, and also describes typical applications used in the production room for special effects, in the news room for cleaning up actualities and phone feeds, and in television for PA feed to a studio audience.

The applications that follow are merely operational guidelines for the Voice Processor. The particular kind of processing applied in any given situation must be determined by the problems encountered, and by the dictates of the format. What's necessary or appropriate in one case, may not be at all proper in another.

4.2 Using the Parametric EQ/Notch Filter

Great care must be exercised when using equalization. The general precautions are:

4.2.1 Beware Distortion and Noise When a frequency or group of frequencies are boosted, the overall operating level is boosted as well. For example, 12dB of boost (no matter what the frequency) increases the 528's output level 12dB. This kind of boost will reduce headroom by 12dB in every circuit from the 528's own line driver to the last device in the signal chain (transmitter, tape machine, or what have you). Unless signal levels are very low to begin with, the 528's output gain will have to be reduced to compensate for increased levels whenever the equalizer is used for boost.

On the other hand, if the levels within the 528 are too low to start with, using the equalizer for boost may increase noise to unacceptable levels.

If levels are too low, increase the preamp gain (or the output gain of the device feeding the line input).

4.2.2 Know What You Are Listening To Low frequency boost may increase the level of some frequencies that cannot be heard, for one reason or another. Many high quality microphones are capable of generating substantial output at very low frequencies (below 50Hz) which cannot be adequately reproduced by most monitor speakers or headphones. Be aware that the true effects of low frequency boost may not be audible, and may actually result in a "muddy" or distorted sound.

4.2.3 Use Wide Peaks, Narrow Notches In general, the human ear prefers wide bandwidth peaks and narrow bandwidth notches. Boosting a narrow bandwidth produces a sound usually perceived as "offensive," while boosting wider bandwidths (.72 octave or greater) usually results in a sound deemed "musical." It has also been observed that very few people will notice anything's missing when a narrow bandwidth (.3 octave or less) is cut, even when it's cut as much as 30dB. But, cut a wide bandwidth and the resulting sound quality is often called "empty."

4.2.4 Tuning the EQ/Notch Filter To "tune" the equalizer, use full boost. For both boost and cut, the 528's parametric equalizer/notch filter is intended to be put to work on specific frequencies. To find a particular frequency "by ear" (the method used by everyone who doesn't have a real-time analyzer), turn the cut/boost control all the way up to +15dB (be very careful of feedback if you are monitoring on a loudspeaker!). Set the bandwidth for about .3 octave. Tune the frequency control until you distinctly hear the part of the sound you wish to control. Then, adjust the cut/boost control for the appropriate amount of change, and readjust the bandwidth control if necessary.

To notch out interference like 60Hz hum, follow the procedure above to get an approximate setting for the frequency control. Then, to fine tune the notch for the best possible rejection of the interference, turn the cut/boost control all the way down to -30dB. Very carefully adjust the frequency control for minimum hum. Then reduce the bandwidth to about .2 octave, and readjust the frequency control for minimum hum. Repeat this process until the narrowest possible bandwidth is achieved.

4.2.5 Parametric EQ/Notch Filter Examples The parametric equalizer/notch filter can be made to behave like many different kinds of equalizer, and to perform many filter functions. The following examples show a group of representative frequency vs. amplitude curves, the control settings that produced them, and in some cases suggested uses for the type of curve shown.

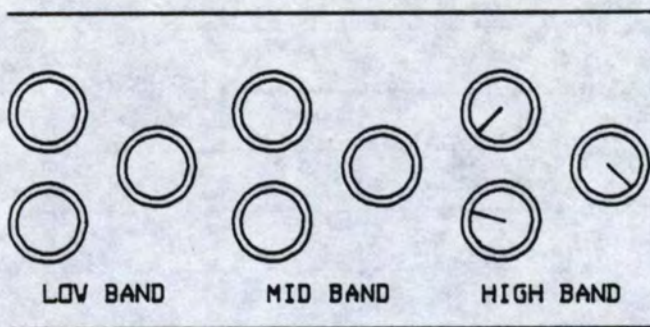

Figure 4.1A High frequency cut.

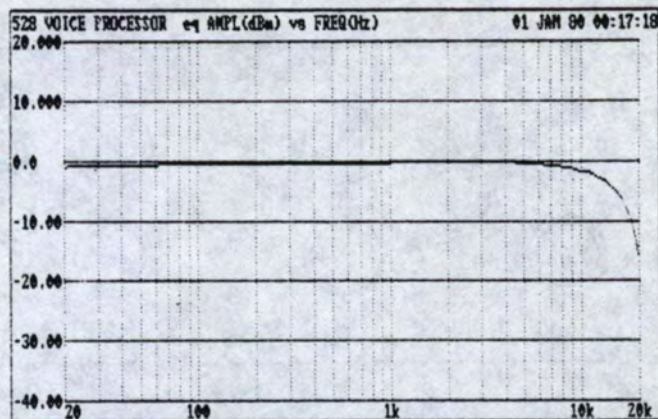

Figure 4.1B Transfer function provided by settings shown at left.

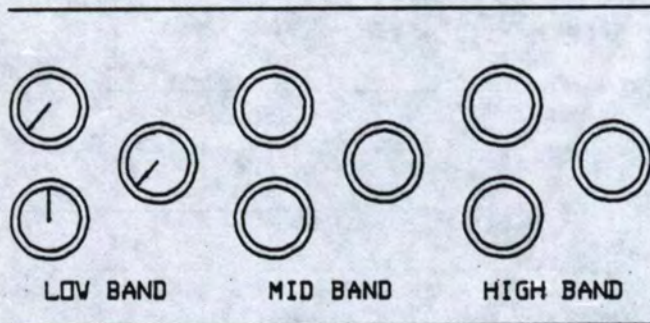

Figure 4.2A Low frequency cut.

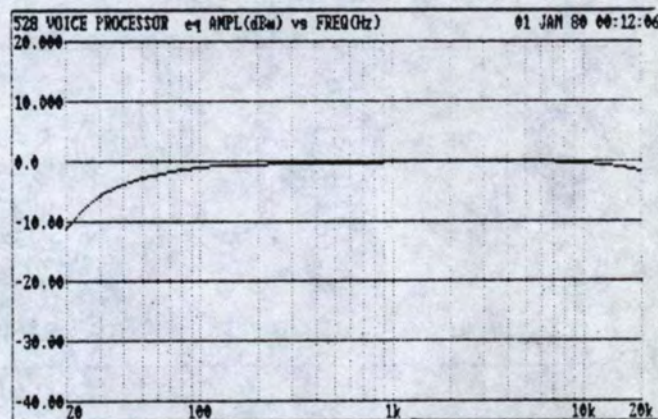

Figure 4.2B Transfer function provided by settings shown at left.

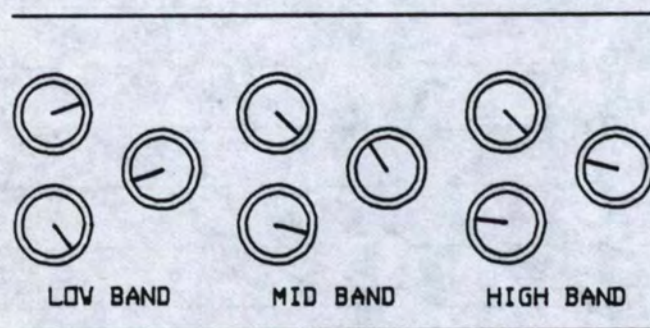

Figure 4.3A "Filter mic" telephone simulation.

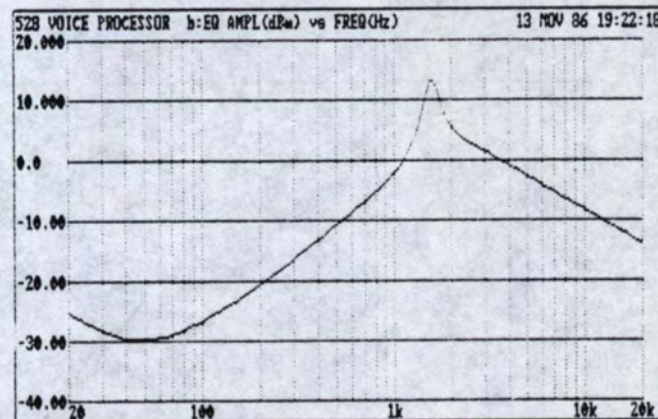

Figure 4.3B Transfer function provided by settings shown at left.

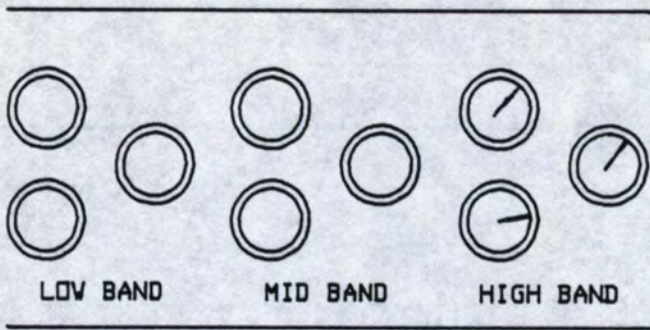

Figure 4.4A Typical settings to add "crispness."

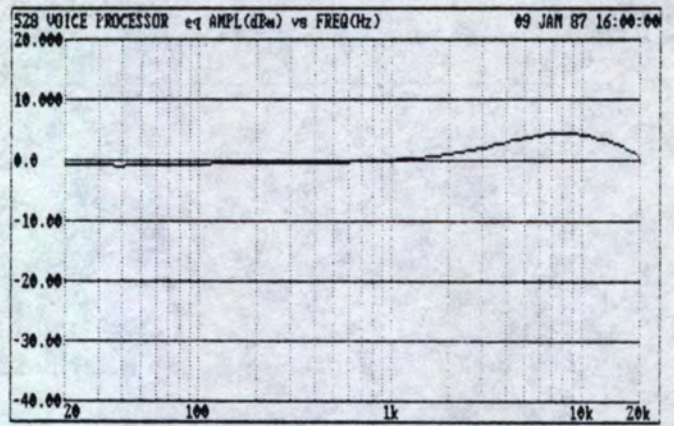

Figure 4.4B Transfer function provided by settings shown at left.

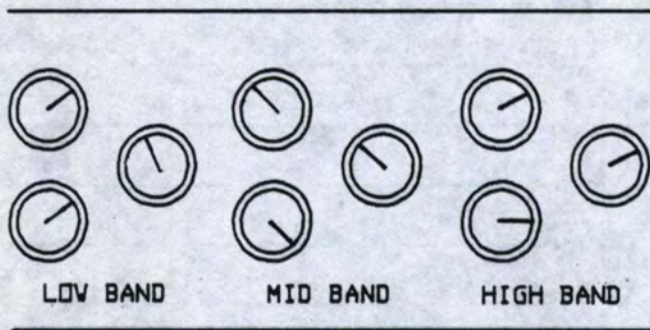

Figure 4.5A "Loudness compensation" to make music beds seem "full" under voice-overs.

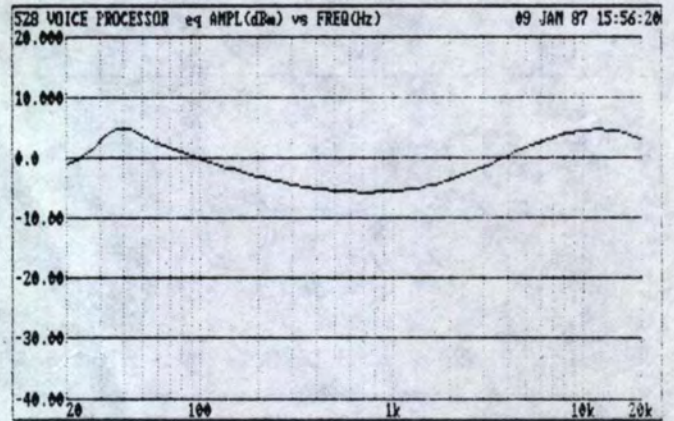

Figure 4.5B Transfer function provided by settings shown at left.

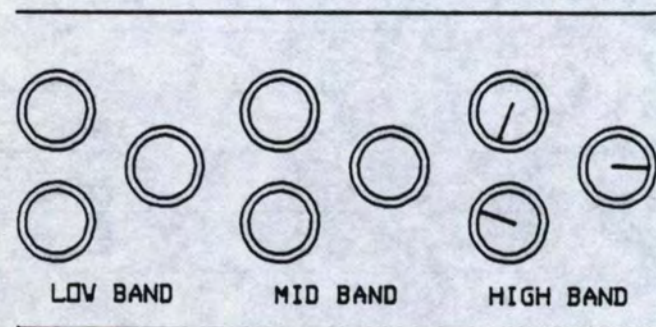

Figure 4.6A Removing 15,750Hz sync leakage using notch filter technique.

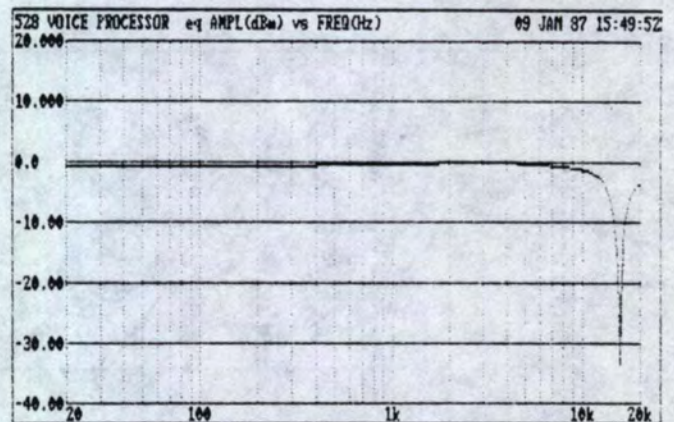

Figure 4.6B Transfer function provided by settings shown at left.

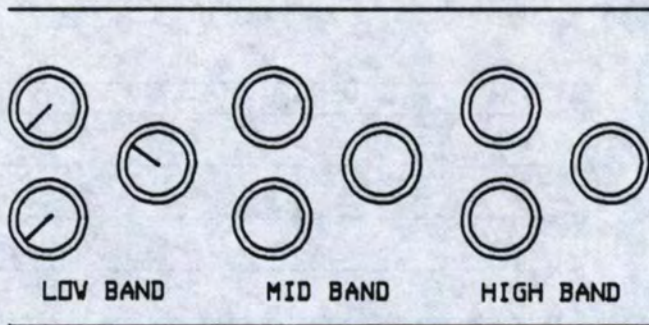

Figure 4.7A Removing 60Hz hum, using notch filter technique.

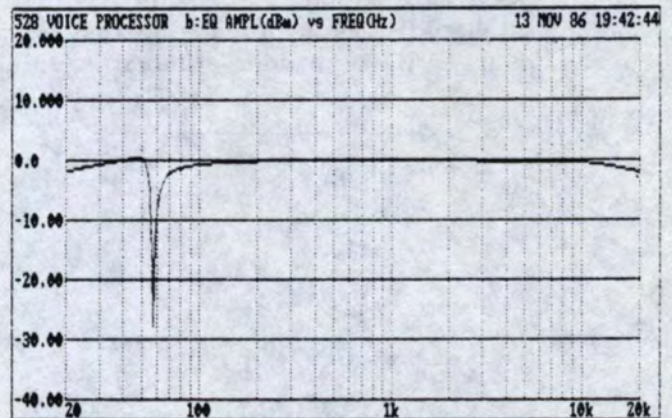

Figure 4.7B Transfer function provided by settings shown at left.

4.3 Announce Mics - Compressing, Limiting, Expanding

The 528's dynamic range processor is used to control both over-modulation and noise. Noise, in this case, may be electrically induced (hum, buzz, etc.), or acoustically transferred (paper rattling, cart solenoids, air conditioning, etc.), since the downward expander attenuates all below threshold signals without regard to origin. Careful adjustment of the two threshold controls allows the operator to put the 528 to work on any portion of the dynamic range. The EXPAND THRESHOLD control governs the 528's activity in the lower part of the dynamic range, while the COMP THRESHOLD governs activity in the upper part of the range.

For smooth overall dynamic range processing that will tend to "homogenize" the sound and remove only very low level noises, use a gentle COMPRESSION RATIO with a relatively high COMP THRESHOLD, and a relatively low EXPAND THRESHOLD.

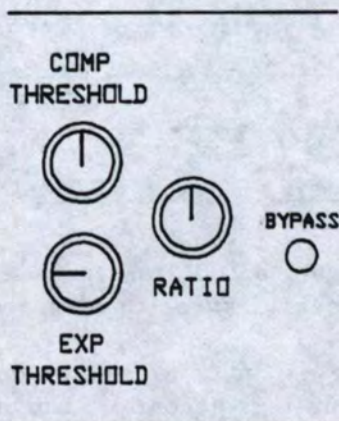

Figure 4.8A Settings for gentle dynamic control of announce mic.

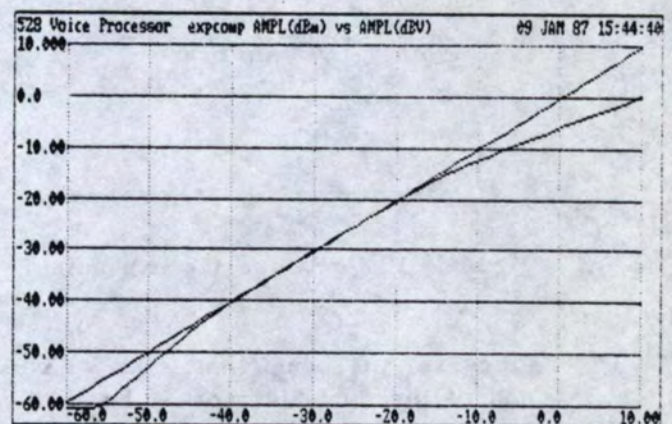

Figure 4.8B Transfer function provided by settings shown at left.

The soft-knee transition characteristic of the interactive processor allows the use of much higher comp/limiter ratios with much lower thresholds. The expander's rapid rise below its threshold, combined with the compressor's smooth transition through its threshold, makes processing to go unnoticed. Use this application to "tighten up" voice-overs. The expander eliminates noise and adds "punch."

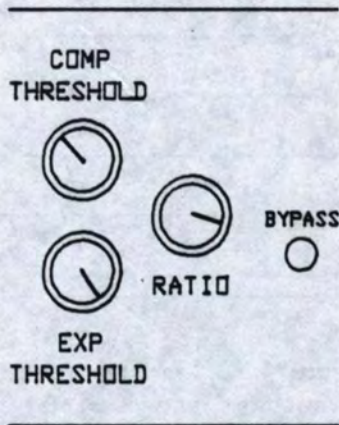

Figure 4.9A Settings for "tight" control of announce mic.

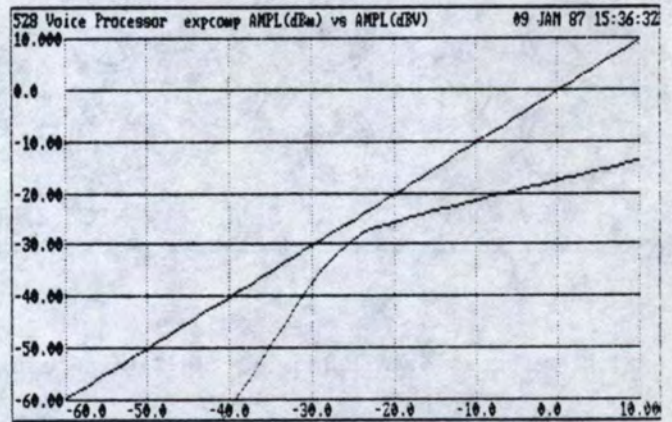

Figure 4.9B Transfer function provided by settings shown at left.

The expander may be used without the compressor to remove background noise. Be sure the EXPAND THRESHOLD is set low enough to allow even the lowest level speech sounds to pass, and the COMP RATIO is set to 1 (so the comp/limiter is essentially out of circuit).

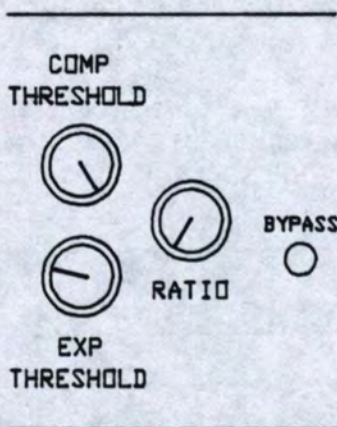

Figure 4.10A Settings for expanding.

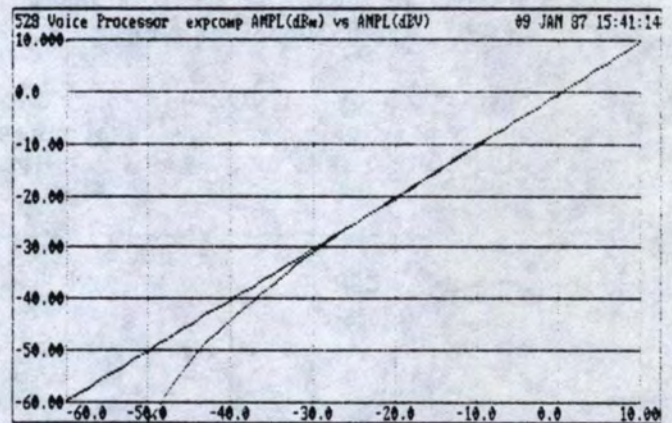

Figure 4.10B Transfer function provided by settings shown at left.

Likewise, the comp/limiter may be used without the expander to control only the upper end of the dynamic range. For general purpose overall gain control, use compression. Set the RATIO between 2:1 and 3:1, with a COMP THRESHOLD setting that results in 6dB to 10dB attenuation.

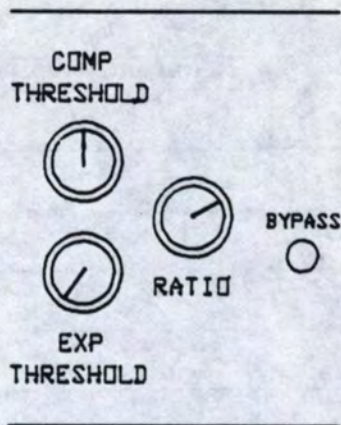

Figure 4.11A Settings for compression.

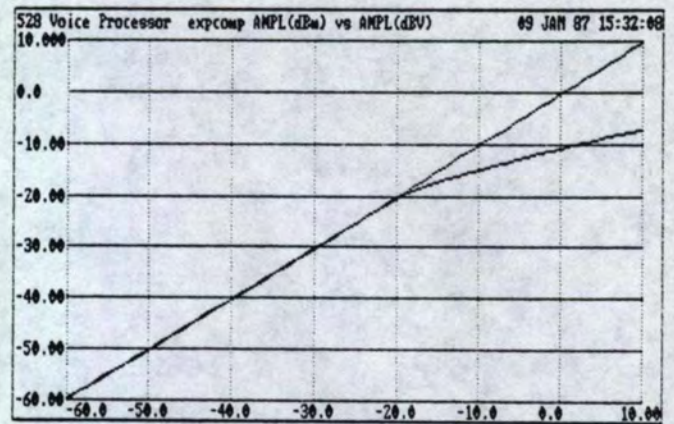

Figure 4.11B Transfer function provided by settings shown at left.

Limiting is used for very definite control of the maximum level. As the name implies, limiting sets the upper limit, but is not intended for general purpose overall gain control. For limiting, set the RATIO at 20:1, with the COMP THRESHOLD control set to provide no more than 3dB to 6dB attenuation.

Bear in mind that limiting is an extreme dynamic control action intended to prevent overload farther down the line. Limiting may be more pleasing to the ear than clipping distortion, but it doesn't sound good enough to be used for more than 6dB attenuation.

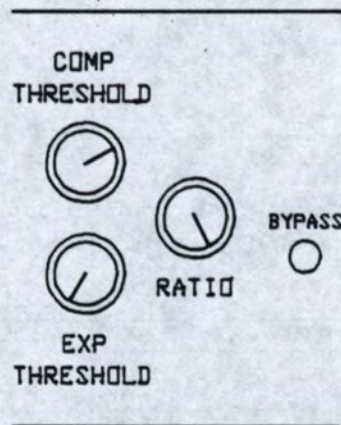

Figure 4.12A Settings for limiting.

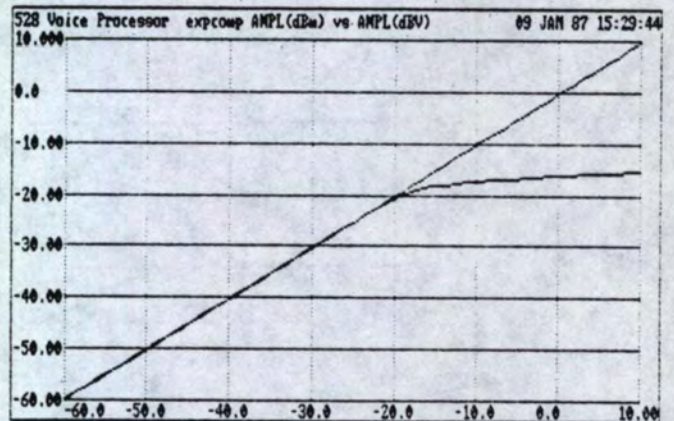

Figure 4.12B Transfer function provided by settings shown at left.

4.4 Using the De-esser

De-essers are used to reduce the level of certain high frequency vocal sounds like sibilance, over-emphasized fricatives, and lip smacking. The 528's de-esser provides control over much lower frequencies than would normally be considered "essing." However, as can be seen in the response graphs shown alongside their control settings below, the versatility of the de-esser is greatly enhanced by the variety of available combinations produced by the RANGE and FREQUENCY controls.

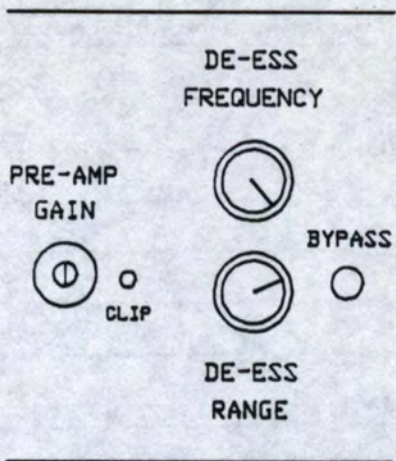

Figure 4.13A "Mild" de-essing, at 8kHz.

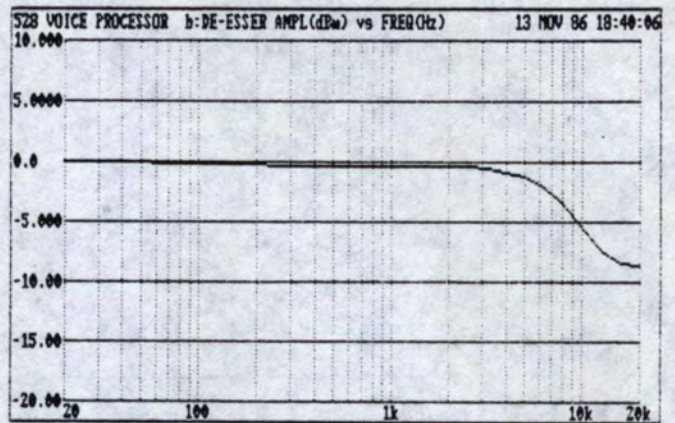

Figure 4.13B Transfer function provided by settings shown at left.

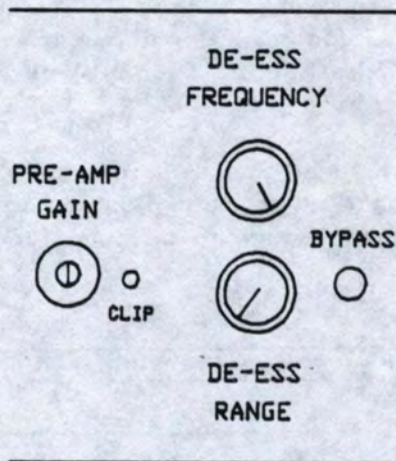

Figure 4.14A "Heavy" de-essing, at 8kHz.

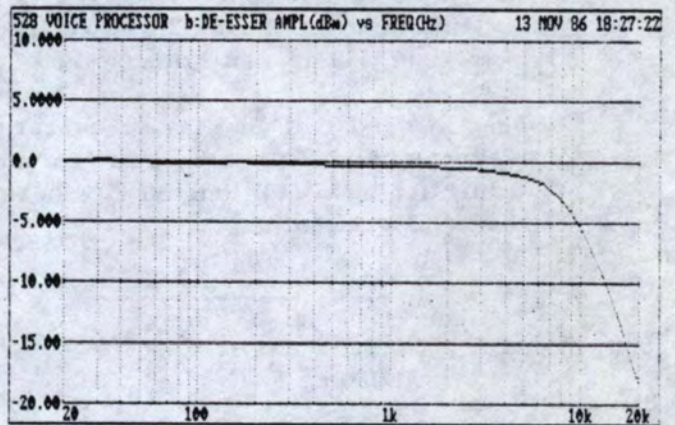

Figure 4.14B Transfer function provided by settings shown at left.

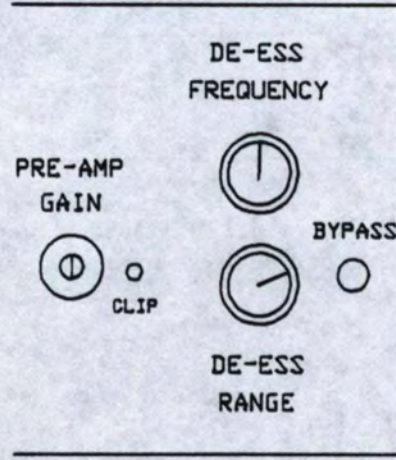

Figure 4.15A "Mild" de-essing, at 2kHz.

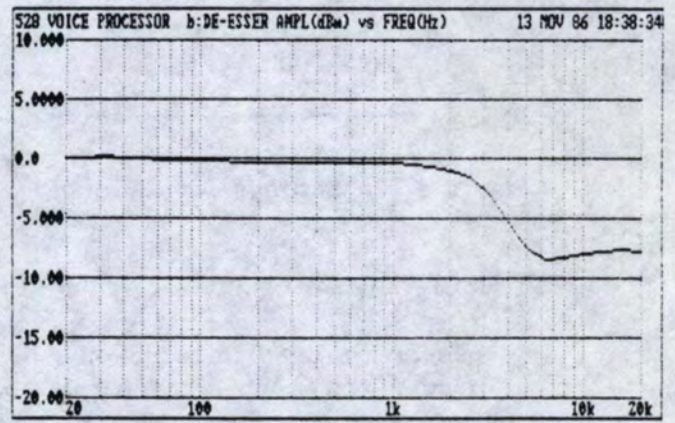

Figure 4.15B Transfer function provided by settings shown at left.

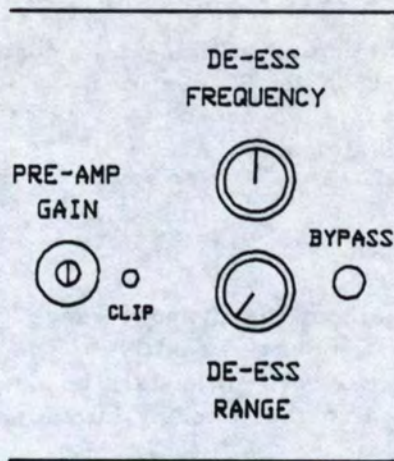

Figure 4.16A "Heavy" de-essing, at 2kHz.



Figure 4.16B Transfer function provided by settings shown at left.

4.5 Cleaning Up News Feeds

Use the de-esser to reduce unnatural high frequencies, the comp/limiter to prevent overload, the expander to eliminate noise, and the parametric to make the feed sound better and/or get rid of interference.

Actualities carts that are prepared with the 528 produce an end product with better intelligibility and improved signal to noise ratio. The object of the processing is to keep dynamic range within the real limits of the recording equipment, to eliminate extraneous noise and get better sound.

4.6 Increasing Gain Before Feedback

To optimize a PA system's response for minimum feedback, tune out feedback with the EQ/Notch Filter. To find and eliminate resonances that can become feedback problems, turn the system on, with the microphone(s) and speaker(s) in place as they will normally be used, then follow the sequence below. Gain before feedback should increase about 6dB (perhaps as much as 15dB) with this technique.

Step 1. Increase system gain very carefully until a feedback frequency becomes slightly audible.

Step 2. With the BANDWIDTH set at about .3 octave, and the CUT/BOOST control set for about -15dB, tune the FREQUENCY control of one section until the feedback is no longer audible.

Step 3. Increase system gain until feedback becomes slightly audible again.

A. If it's the same frequency that was heard first, readjust the same FREQUENCY and BANDWIDTH controls until it again subsides.

B. If it's a new frequency, repeat Step 2 using another of the EQ sections.

Step 4. Increase gain again to find the third most prominent feedback frequency. Repeat Step 2 using yet another of the EQ sections.

Step 5. Reduce system gain to normal operating levels.

4.7 Parametric EQ in the Sidechain

The EQ/Notch Filter can be placed in the sidechain of the dynamic range processor to make compression, limiting, or expanding action frequency sensitive. The equalizer is patched into the sidechain, so the audio signal that will ultimately become the VCA's control voltage can be equalized before being fed to the detector circuitry (see Section 1.10).

If the 528 has been wired to a patch bay, interconnect:

1. C/L-EXP SIDECHAIN OUT to EQ IN
2. EQ OUT to C/L-EXP SIDECHAIN IN
3. CL-EXP OUT to LINE DRIVER IN

If the unit has not been wired to a patch bay, the shorting connectors between terminals 9/10 on barrier strip TB1, and 1/2 and 4/5 on barrier strip TB2 must be removed. Then, connect:

1. TB1/9 to TB2/2
2. TB2/4 to TB1/10
3. TB2/1 to TB2/5

To make the 528's comp/limiter more sensitive to high frequencies, boost the high frequencies on the equalizer. This increases the sensitivity of the control circuits to those particular frequencies, so the comp/limiter responds more to those frequencies than any others. If the offending frequencies produce a control signal of greater amplitude than the desired frequencies, they will control how the comp/limiter behaves with the rest of the signal as well. However, if the offending signals are of significantly greater amplitude than the rest of the signal, careful adjustment of the COMP THRESHOLD (combined with the boost provided by the EQ in the loop) will make the comp/limiter respond only to the boosted frequencies.

Keep in mind that the COMP THRESHOLD becomes a function of the amount of overall gain through the equalizer, including the boost. This technique can be used with any frequency that can be controlled by the equalizer.

Cutting a frequency will create the inverse effect, making the 528 *less* sensitive to frequencies that are cut from the control signal.

4.8 Using Sidechain EQ to Enhance Expander Action

Since the expander can only discriminate between different levels (not different sounds), it can be fooled by signals whose levels are nearly the same, even if the frequency content of those signals is fundamentally different. When the 528's expander is used to shut out unwanted sounds, any signal that exceeds threshold will trigger the expander.

When unwanted signals trigger the system, it's often possible to eliminate the false triggering by equalizing the control signal.

For example, if low frequency signals transmitted through a desk or podium are triggering the 528's expander unnecessarily:

- With an equalizer in the sidechain, remove the low frequencies from the control signal,

and/or

- Boost the higher voice range frequencies.

When the offending frequencies are removed, and the relative level of the desired frequencies is increased, the expander can tell the difference between the wanted and unwanted signals. Use this technique in any situation where levels are nearly the same, but the fundamental frequencies involved are different.

NOTE

The ability of the expander to discriminate between wanted and unwanted signals is determined in part by mic technique. Be particularly careful of high frequency sounds entering the side or rear pattern of a cardioid mic. Most cardioids exhibit a sharply rising off-axis response characteristic at higher frequencies. Check the off-axis curve (the lower one) in the manufacturer's literature. If there's only a 3dB to 6dB difference between the on-axis (front) response and the off-axis (side or rear) response in the 5kHz to 10kHz region, high frequency sounds will be picked up by the side or back of your mic.

Use the mic's directional pattern to keep other sources as far off-axis as possible - do everything you can to extract all the source-to-source discrimination possible through good mic technique. The sounds picked up by individual mics must be primarily the sound of the the desired signal, or the expander won't be able to tell the difference.

4.9 Using Reverb or Effects

Effects usually require another mixer input for effects return. However, the 528's patching connections can be used to feed a signal to the effects unit, and the STACKING INPUT can be used to return the effects signal to the 528's output. The only requirement is that the effects device have an input or output level control to set the direct/effects signal mix.

4.10 Vocal Processing - Recording and Reinforcement

The 528 handles a wide variety of program material with ease. When recording vocals, the undesirable side effects that usually result from high ratio comp/limiting, like headphone leakage and room noise, can be reduced with the 528's interactive expander

processing. During mixdown the 528 not only provides compression, but also eliminates the noise that often accompanies vocal tracks that are processed with high frequency EQ, compression, or both.

In sound reinforcement situations, the expander will attenuate whenever a mic is not in use, eliminating extraneous pickup of stage sounds, and reducing feedback from monitor speakers. The operating principle is the same for both the recording and reinforcement situations.

4.11 Adding Dynamics, or "Punch"

By setting the EXPAND THRESHOLD above the level of the program material, the 528 can be made to behave like a linear expander (see Section 1.11). With this technique, the 528 can simultaneously create a more dynamic feel, add compression, and reduce noise. Use this kind of processing for special effects, and to increase the dynamic feel of percussive instruments like electric bass, snare drum, rhythm guitar, etc.

Set the EXPANDER THRESHOLD *above* the signal level. The comp/limiter is used to control peaks (and with certain instruments like electric bass, to put in a little more "bottom" by creating extra sustain). Set the COMP THRESHOLD so the maximum compression is about 6dB with ratios below 2:1, or 3dB with ratios above 2:1.

Since this kind of processing reduces overall output level, use the OUTPUT GAIN control to bring levels back up to normal.

4.12 High Level Stage Monitors - Dynamic Processing

Public address and sound reinforcement situations that require comp/limiting are often plagued by feedback problems. Usually the "make up gain" used with compression causes an overall increase in level which in turn, can cause feedback in the absence of signal, when the compressor releases and brings levels back up to normal.

The 528's interactive dynamics processor allows the use of large amounts of comp/limiting without serious side effects. When compression is applied to "normal" signal levels, the compressor returns to unity gain when the signal goes away. This action increases overall system gain. The 528's expander, on the other hand, decreases gain whenever signals fall below threshold. Careful setting of the two threshold controls tells the 528 how and when to adjust the gain.

Stage monitors can be made much "tighter" with compression, but feedback problems often make even gentle, low ratio compression impossible. The 528's interactive processor performs exceedingly well in this situation, because the expander decreases gain to compensate for the gain increase that results from compression.

Careful adjustment of the EXPANDER THRESHOLD control will prevent feedback in the absence of signal, even with substantial compression. Note that in most cases the EXPANDER THRESHOLD must be set higher than the COMP THRESHOLD.

5. 528 Specifications

Mic Preamp:

Type	Balanced, transformerless
Phantom power.....	+48V, nominal
Gain	variable, 23dB to 50dB
Maximum input level.....	-3dBV
Equivalent input noise	-127dBm
(150 ohm source, 20Hz-20Khz)	
THD05%
(@2kHz, 50dB gain, +15dBm output)	
CMMR (@40dB gain).....	>50dB typical
Clip LED.....	fires at +17dBm preamp output level
Controls.....	Gain, Phantom Power

Line Input:

Type	Balanced, transformerless
Input impedance.....	>15k ohms each leg
Maximum input level.....	+18dBV

De-esser:

Type	Program controlled high cut
Corner frequency	Variable 800Hz to 8kHz
Range.....	0dB to 20dB
Controls.....	Range, Frequency, Bypass

Dynamic Range Processor:

Type	Interactive comp/limit/expand
Compression Ratio	1:1 to 20:1
Compressor Threshold.....	-50dBm to +20dBm
Expander Threshold.....	0dBm to -60dBm
THD (2kHz, 10dB comp. or expand).....	.025%
Controls.....	Expand Threshold, Comp Threshold, Comp. Ratio, Bypass

Parametric EQ/Notch Filter:

Boost/Cut.....	+15dB, >-30dB
Low Band.....	16Hz to 512Hz
Mid Band.....	196Hz to 6.3kHz
High Band.....	686Hz to 22kHz
Bandwidth	Variable, .05 octave to 3.3 octave

Output Section:

Type	Balanced, transformerless
(Transformer coupled output option available: Model 528-01)	
Maximum output level.....	+24dBm Bal./+18dBm Unbal.
Clip LED.....	Senses multiple nodes
(Fires at 3dB below clipping)	
Output impedance	100 ohms, balanced or unbalanced
Minimum load impedance	600 ohms
Output Gain	+/-15dB
Output Level Meter:.....	-20 to +6 VU
Gain Reduction Meter:.....	-40dB to -3dB
(Switchable to read Comp/Limit/Expand or De-esser)	

The 528 meets the requirements of Deutsche Bundespost. Specifications subject to change without notice.

6. Troubleshooting Guide

Make the following tests one at a time to isolate a problem you think may be caused by the 528 (or any other unit).

1. Make sure the unit is plugged in, and the pilot LED is lighted.
2. Bypass the device in question by directly connecting the cable feeding the input to the cable feeding the output (with a double female adapter). Listen to the system with this direct connection in place. If signal passes through this direct connection, but not through the unit, the trouble is with the unit.
3. Check INPUT, OUTPUT, SIDECHAIN and patching wires and connectors carefully. MOST MALFUNCTIONS ARE WIRE OR CONNECTOR RELATED.
4. Plug headphones directly into outputs to see if signal is present. If you cannot hear the signal at the unit's output, work your way back through the chain until you can hear it. (If you get all the way back to the input without hearing anything, get competent help.)
5. BE SURE ALL JUMPERS ARE IN PLACE ON THE REAR PANEL TERMINAL STRIPS. THE SIGNAL PATH MUST BE COMPLETED. SEE "NOTE" ON PAGE 8.

6.1 Troubleshooting Table

Problem	What to check - what to do
No expand/gate action	<ol style="list-style-type: none">1. Is the CHANNEL IN switch depressed?2. Is there something in the sidechain that's not turned on?3. Is there a 2-conductor (mono) plug in the sidechain?4. Is the EXPANDER THRESHOLD set low enough for the present signal level?
No compress/limit action	<ol style="list-style-type: none">1. Is the CHANNEL IN switch depressed?2. Is there something in the sidechain that's not turned on?3. Is the COMP THRESHOLD set low enough for the present signal level?
Low or distorted output	<ol style="list-style-type: none">1. Be sure gear patched into the sidechain is turned on.2. Check INPUT, OUTPUT and SIDECHAIN connectors for shorts.3. Is something patched into the signal chain before or after the 528?4. Is the 528 powered up?
Distortion or crackling sound at output	<ol style="list-style-type: none">1. Check level and signal at input: Is it too high? Is it distorted?

7. Service Information/Schematics

Symetrix will service any of its products, no matter when it was manufactured or what condition it's in. However, no goods will be accepted without a Return Authorization number. If we don't know it's coming we won't be prepared to make the necessary repairs, so we won't accept it.

BEFORE SENDING ANYTHING TO SYMETRIX, CALL FOR AN R/A NUMBER. JUST ASK, WE'LL GLADLY GIVE YOU ONE! CALL (206) 282-2555 WEEKDAYS, 8 AM TO 4 PM PACIFIC TIME.

7.1 In-Warranty Repairs

The 528 Voice Processor is covered by a limited warranty for a period of one year from the date of purchase. The Limited Warranty attached inside this manual spells out all the legal details, and the generalities that follow are not intended modify that warranty statement.

To get your unit fixed:

1. Call for an R/A number.
2. Pack the unit in its original packaging materials.
3. Put the R/A number on the outside of the box.
4. Ship it to Symetrix freight pre-paid.

Just do those four things, and repairs made in warranty will cost you only the one way freight fee. We'll pre-pay the return freight.

However, if you send it to us in some kind of flimsy non-Symetrix packaging we'll have to charge you for proper shipping materials. We won't return the unit in anything but the original Symetrix packaging. And of course, if the problem turns out to be operator inflicted, you'll have to pay for both parts and labor. In the event there is a charge, we'll still pay for the return freight, but all other charges will be C.O.D. (and we do mean CASH on delivery).

7.2 Out-of-Warranty Repairs

We'll gladly service any Symetrix product, any time. If the warranty period is passed you'll be billed for all necessary parts, labor, and packaging materials, as well as any applicable freight charges.

Remember, you must call for an R/A number before you send the unit to Symetrix.

7.3 Schematic Diagrams

The schematic diagrams are to be used by qualified service technicians only. No license to use this information for anything other than normal repairs is implied or given by the inclusion of proprietary information in the schematic diagrams in this operator's manual.

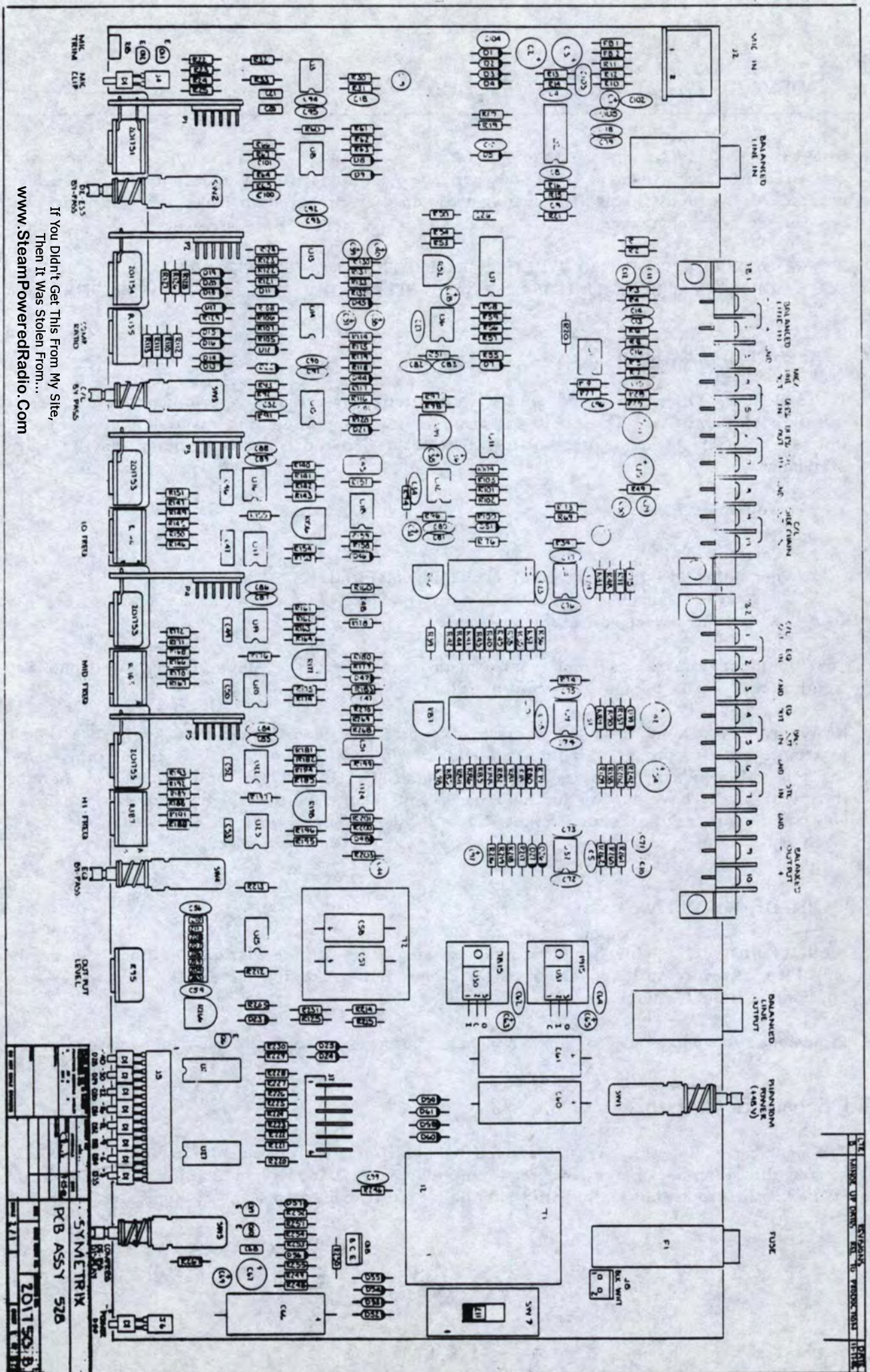

If You Didn't Get This From My Site,
 Then It Was Stolen From...
www.SteamPoweredRadio.Com

PCB ASSY 520
 SYMMETRIX
 Z01150 B

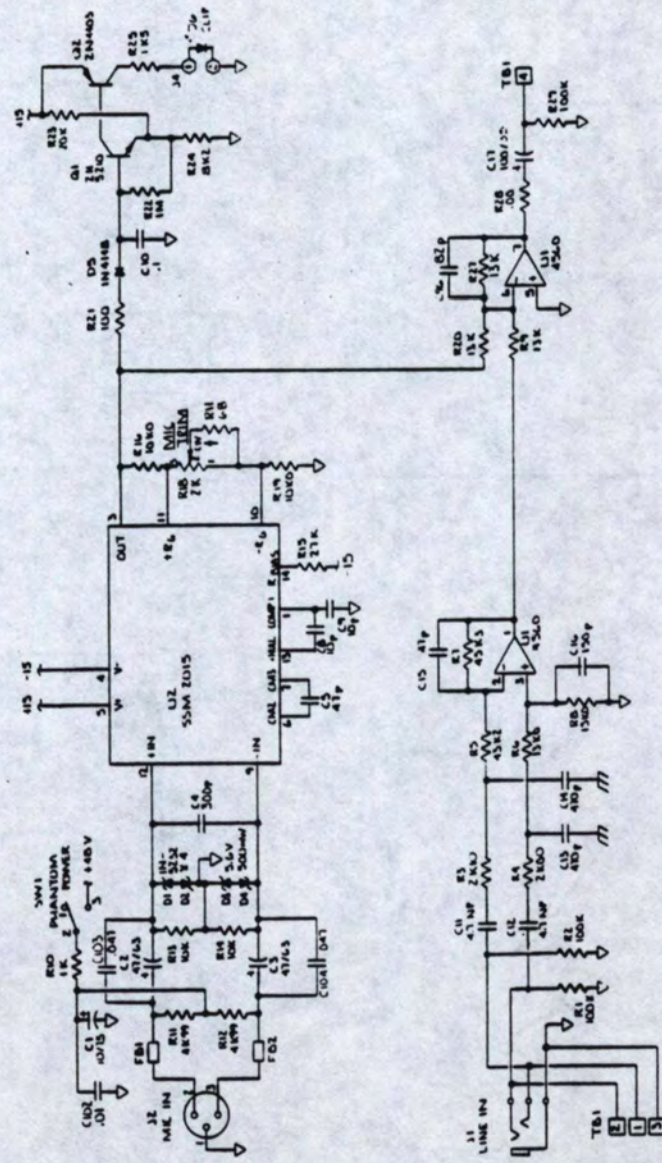

- NOTES:**
1. CAPACITOR VALUES ARE IN pF.
 2. RESISTOR VALUES ARE IN OHMS, 2 SIGIF. FIGURES - 5% 3 SIGIF. FIGURES - 1% RESISTORS MARKED 'R' ARE ALL CONTAINED IN A SINGLE DIP RESISTOR NETWORK.
 3. T2 IS INSTALLED IN THE XFMR OUTPUT VERSION. WHEN T2 IS INSTALLED, C51, C52 ARE OMITTED.
 4. CHANGE R212 AND R215 TO 18 OHMS. INSTALL R2125 AND R216. ADJUST R246 TO MATCH ANY OFFSET THAT MAY OCCURE AT U25-7.
 5. REFERENCE 1K SIGNATOR LAST USED:

U25	10	T2	15	12	F2	12	F2	12	F2
U25	10	T2	15	12	F2	12	F2	12	F2
U25	10	T2	15	12	F2	12	F2	12	F2
U25	10	T2	15	12	F2	12	F2	12	F2
U25	10	T2	15	12	F2	12	F2	12	F2
U25	10	T2	15	12	F2	12	F2	12	F2
U25	10	T2	15	12	F2	12	F2	12	F2
U25	10	T2	15	12	F2	12	F2	12	F2
U25	10	T2	15	12	F2	12	F2	12	F2
U25	10	T2	15	12	F2	12	F2	12	F2

ALL SWITCHES SHOWN IN THE OUT POSITION

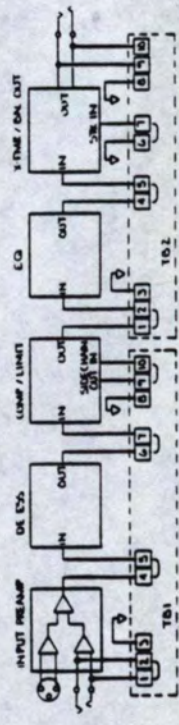

If You Didn't Get This From My Site,
 Then It Was Stolen From...
www.SteamPoweredRadio.Com

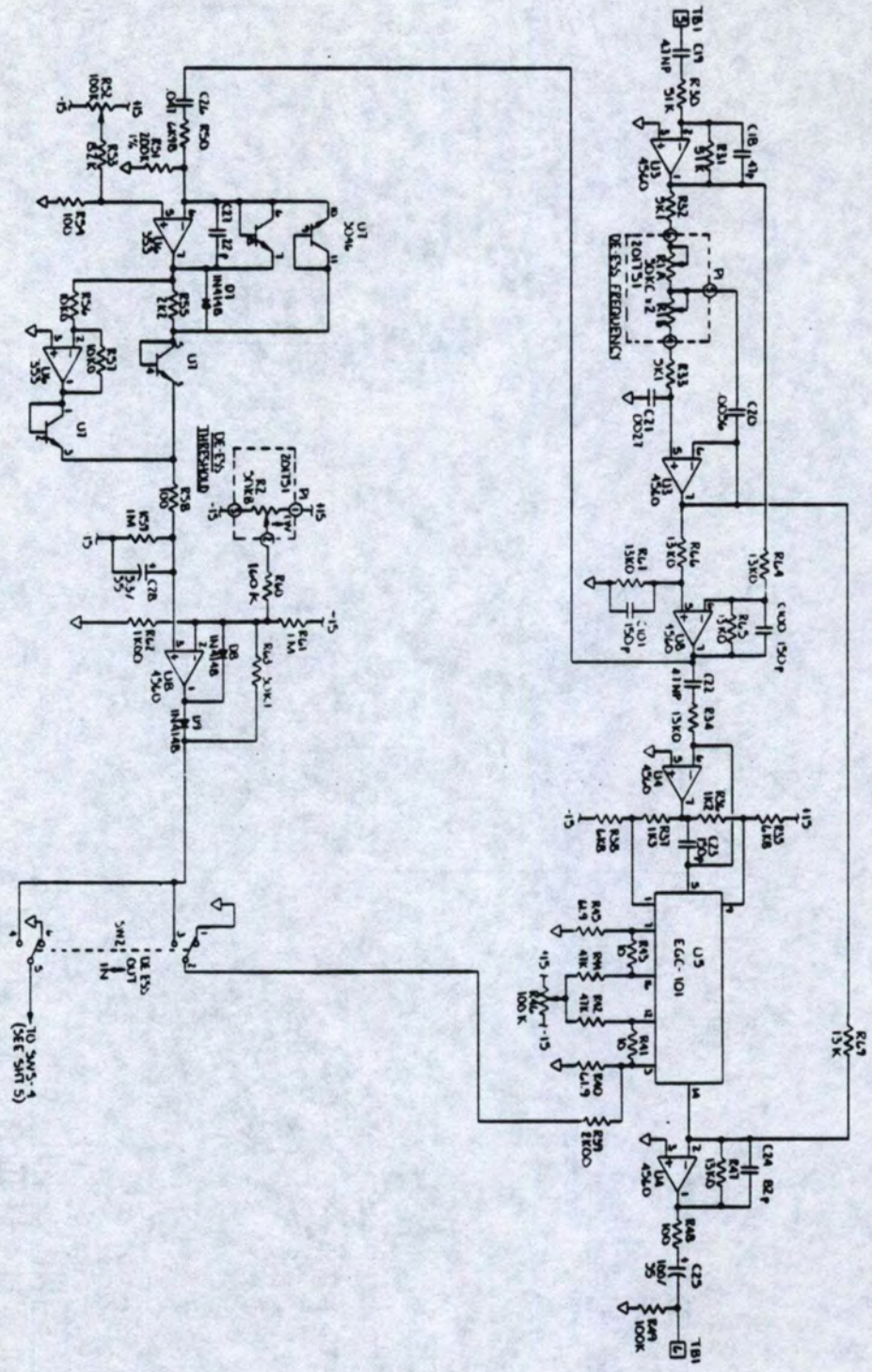

If You Didn't Get This From My Site,
Then It Was Stolen From...

www.SteamPoweredRadio.Com

SYMETRIX	
SCHEMATIC 52B	
191750	B
191750	B

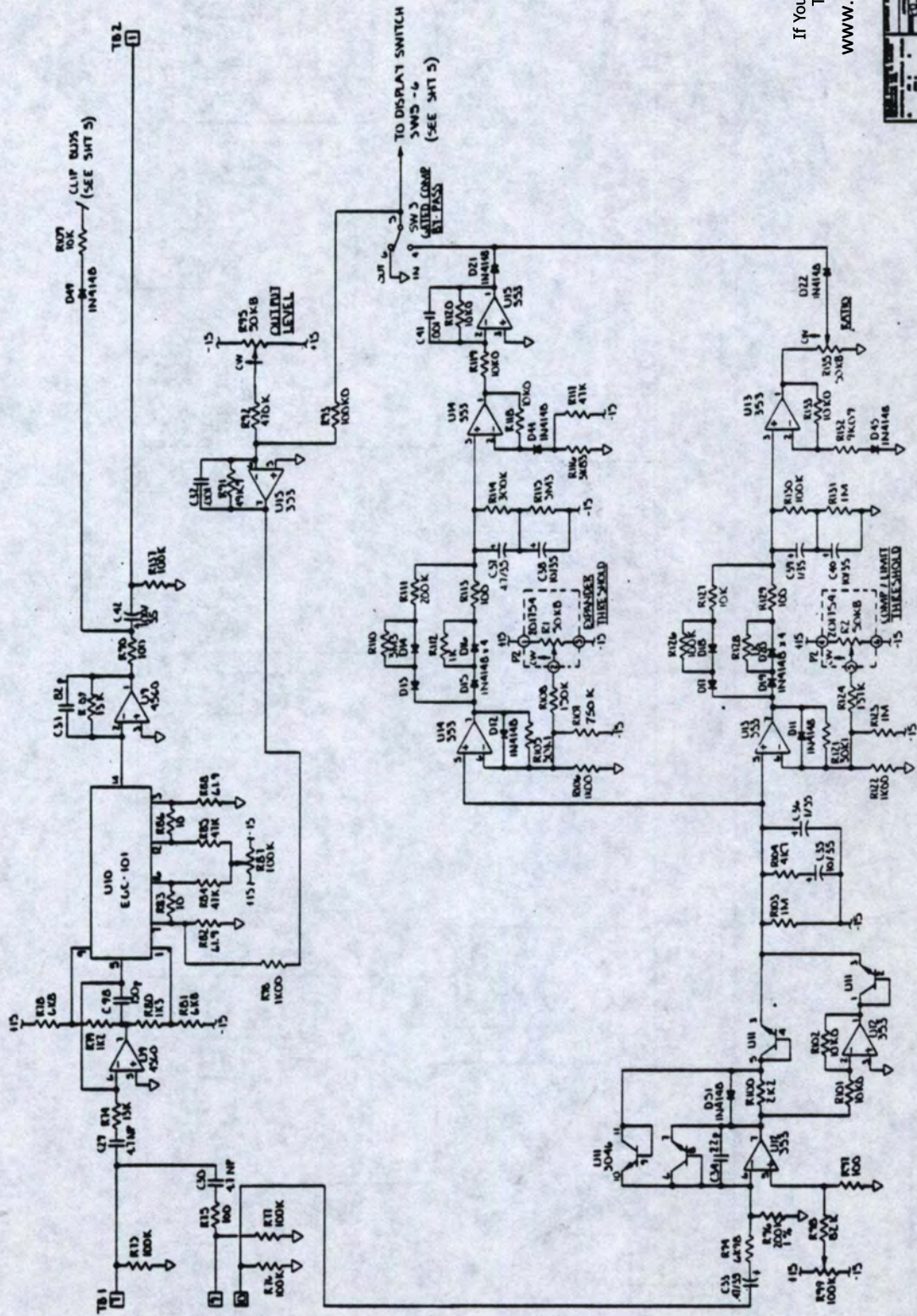

If You Didn't Get This From My Site,
Then It Was Stolen From...
www.SteamPoweredRadio.Com

SYMNETRIX	
SCHEMATIC 528	
191750	B

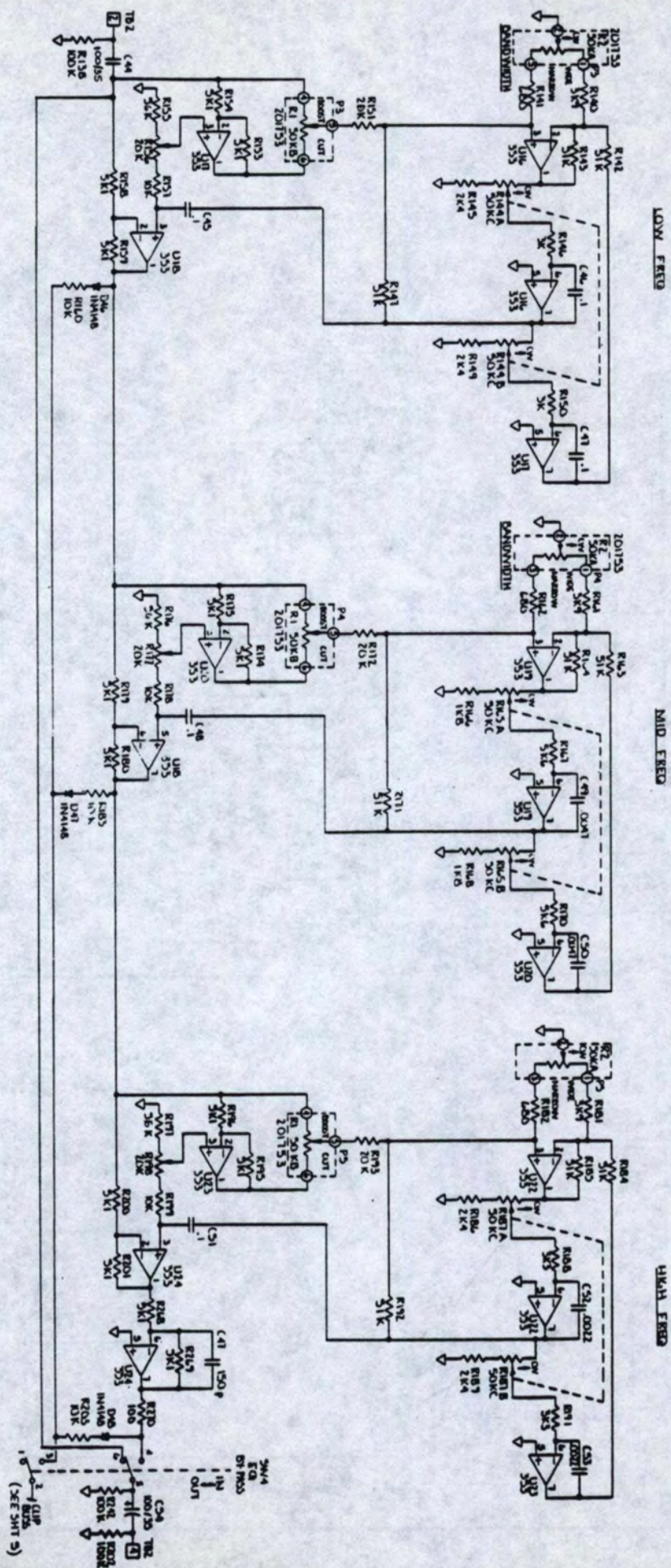

If You Didn't Get This From My Site,
 Then It Was Stolen From....
www.SteamPoweredRadio.Com

SYMMETRIX	
SCHEMATIC 526	
DATE	1971.12.08
BY	...
...	...

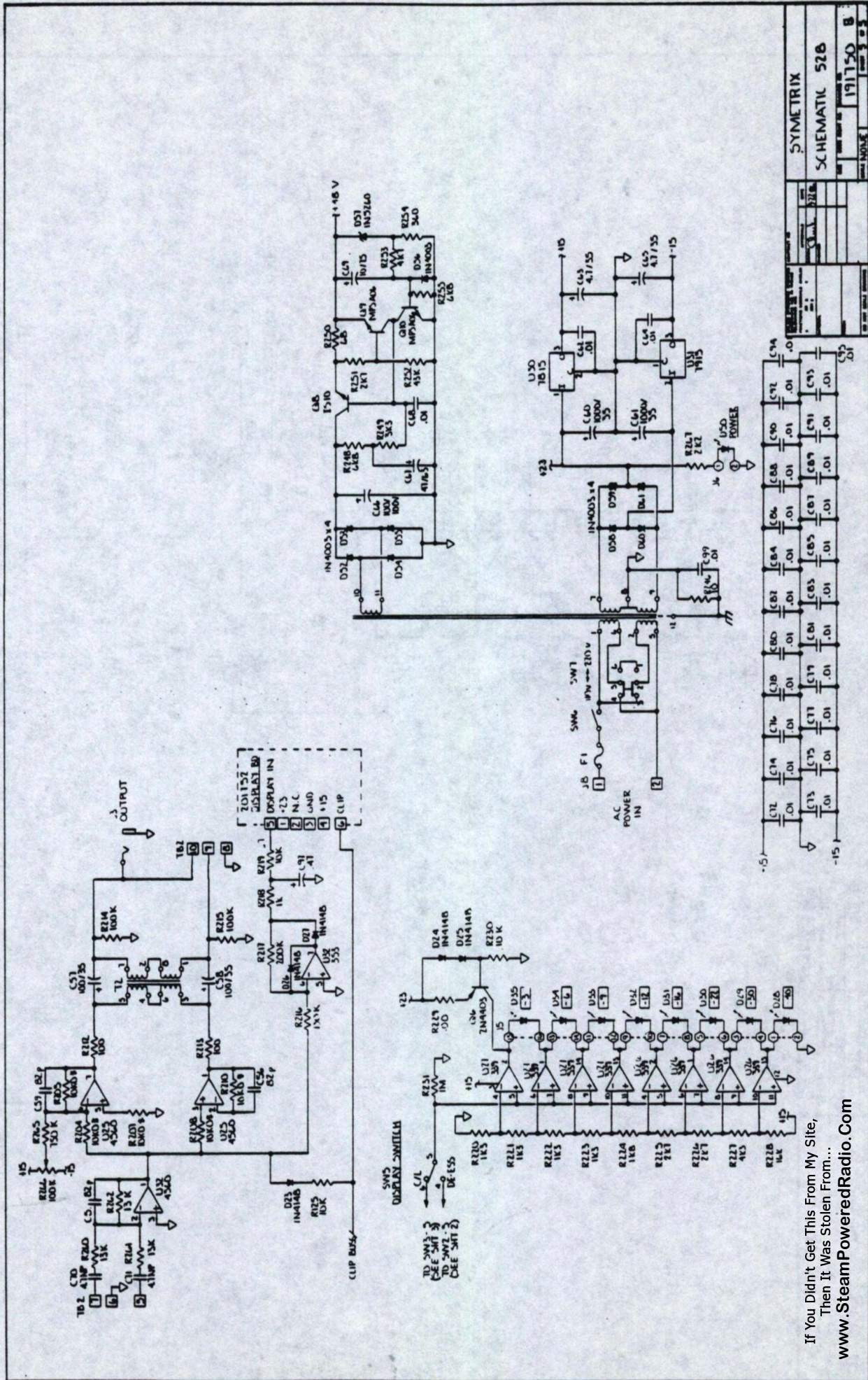

SYMMETRIX
SCHEMATIC 528
1977-50 B

If You Didn't Get This From My Site,
Then It Was Stolen From...
www.SteamPoweredRadio.Com

LT#	REVISIONS	DATE
A	PROTOTYPE UP DATES	10-21-84
-	RELEASED TO PRODUCTION	11-17-84

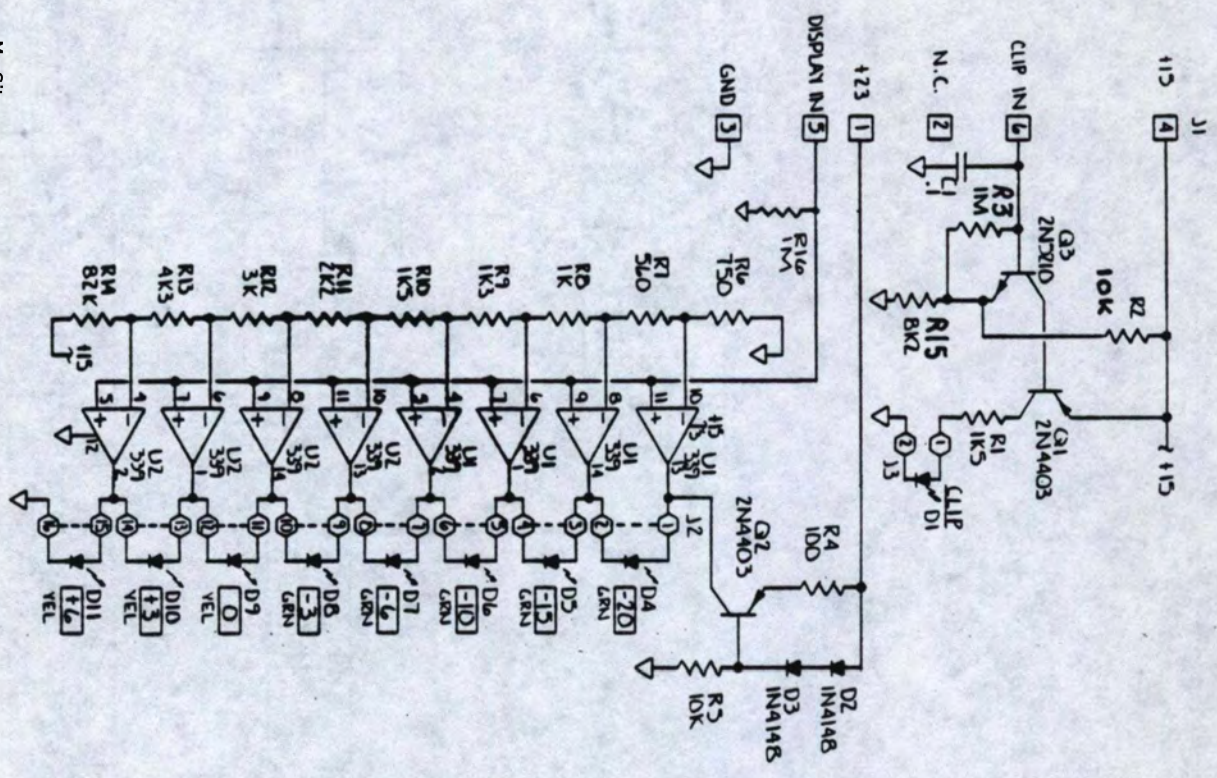

If You Didn't Get This From My Site,
Then It Was Stolen From...

www.SteamPoweredRadio.Com

SYMMETRIX	
SCHEMATIC DISPLAY 52B	
DATE	191702 A
DESIGNER	
CHECKED	
APPROVED	
DATE	
BY	
NO. OF SHEETS	1 OF 1

APPENDIX A - Using Electronically Balanced Inputs and Outputs

Electronically balanced inputs and outputs must sometimes be treated differently from transformer coupled inputs and outputs.

With balanced equipment

When the 528 is used with equipment also equipped with balanced inputs and outputs (of any type):

- Be sure polarities are matched (if desired), then connect:

hi (+) to hi (+)
low (-) to low(-)
ground to ground

The polarity may be changed by reversing the (+) and (-) connections.

With unbalanced equipment

When the 528 is used with equipment having unbalanced inputs and/or outputs:

- To use the 528's inputs with unbalanced outputs, connect:

tip to hi (+)
ground the low (-) input
ground to ground (sleeve)

The polarity may be changed by reversing the (+) and (-) connections.

- To use the 528's terminal strip output with unbalanced inputs, connect:

hi (+) to tip
ground to sleeve
DO NOT CONNECT THE LOW (-) OUTPUT

The polarity may be changed by reversing the (+) and (-) connections. Remember, the 1/4" output jack also provides an unbalanced output.

CAUTION

The 528's electronically balanced output drives both the high and low legs of the output equally, with opposite polarity. Do not ground the unused leg when operating the 528 with unbalanced equipment. Grounding the unused leg will unnecessarily load the output driver, and may increase distortion.

APPENDIX B - Notes on the 528-01 (Option 1)

The 528-01 is identical to the 528 except that the Option 1 type uses a Jensen Model 123-SPC output transformer in place of the electronically balanced output in the 528 standard unit. The Option 1 (consisting of transformer T2) configuration is shown on the schematic drawing 191750B (5 of 5), included with this manual.

Note the differences between the two configurations: In the 528-01 the output coupling capacitors C57 and C58 are omitted. In their place is the above mentioned output transformer.

Symetrix Limited Warranty

A. Warranty Registration must be completed and mailed to Symetrix Inc. (Symetrix) within 30 days of the date of purchase.

B. Symetrix warrants the materials, workmanship and proper operation of this Symetrix product for a period of one year from the original date of purchase. If any defects are found in the materials or workmanship, or if the product fails to function properly within the specified warranty period, Symetrix will repair or replace the product, at its option.

C. To obtain factory service:

1. Call Symetrix for a Return Authorization Number. R/A numbers necessary for proper tracking of your product. Call (206)282-2555 or Telex 703282 SYMETRIX UD 8am to 4pm weekdays (Pacific time).

2. The product must be returned in its original shipping carton, freight prepaid to:

Symetrix, Inc.
4211 24th Avenue West
Seattle, WA 98199 USA

D. Symetrix reserves the right to inspect any products which may be the subject of any warranty claim before repair or replacement is carried out. Symetrix may, at its option, require proof of the original date of purchase (dated copy of original retail dealer's invoice). Final determination of warranty coverage lies solely with Symetrix, Inc. Any Symetrix product deemed eligible for repair or replacement under the terms of this warranty will be repaired or replaced within 30 days of receipt of the product at Symetrix' factory. Products which do not meet the terms of this warranty will be repaired and returned C.O.D. with billing for labor, materials, return freight and insurance. Products repaired under warranty will be returned freight prepaid by Symetrix, to any location within the boundaries of the USA. Outside the USA, products will be returned freight collect.

E. This warranty is extended to the original purchaser, and to anyone who may subsequently purchase this product within the specified warranty period.

F. Symetrix does not authorize any third party, including any dealer or sales representative to assume any liability on behalf of Symetrix, or to make any warranty for Symetrix.

G. The above warranty is the only warranty given by Symetrix, Incorporated and is in lieu of all other warranties. All implied warranties, including warranties of merchantability or fitness for any particular purpose shall be strictly limited in duration to one year from the date of original purchase. Upon the expiration of the warranty period (one year), Symetrix shall have no further warranty obligation of any kind, expressed or implied. Symetrix shall in no event be obligated for any incidental or consequential damages that may result from any defect, or warranty claim of any kind, expressed or implied. Some states do not allow exclusion or limitation of incidental or consequential damages or limitation on how long implied warranties last, so some of the above limitations and exclusions may not apply to you. This warranty provides specific legal rights. The purchaser has implied warranty rights, and may also have other rights which vary from state to state.

SYMETRIX WARRANTY REGISTRATION

Model No. _____ Serial No. _____ Date of Purchase ____ / ____ / ____
Dealer's Name _____ City _____
Purchaser's Name _____ Title _____
Company _____ Dept. _____
Street/Box _____ City _____
State _____ ZIP _____ Telephone Number () _____

USED FOR: Prof. Recording Broadcast Permanent Installation
 Sound Reinforcement Home Studio Other (_____)

I READ: dB Mix Recording Engr/Prod Studio Sound
 Music & Sound Output Electronic Musician Millimeter
 S&VC Sound & Communications Video Radio World
 Broadcast Mgmt/Engrng Broadcast Engineering

Our mutual interest is better products at better prices. We appreciate your taking the time to give us this information, and we appreciate any comments you have: _____

Symetrix

4211 24th Avenue West
Seattle, WA, 98199,USA

