

TRANSMITTER CONTROL DESK

MI-11616



INSTRUCTIONS

Printed in U. S. A.

IB-30157

PH-2489

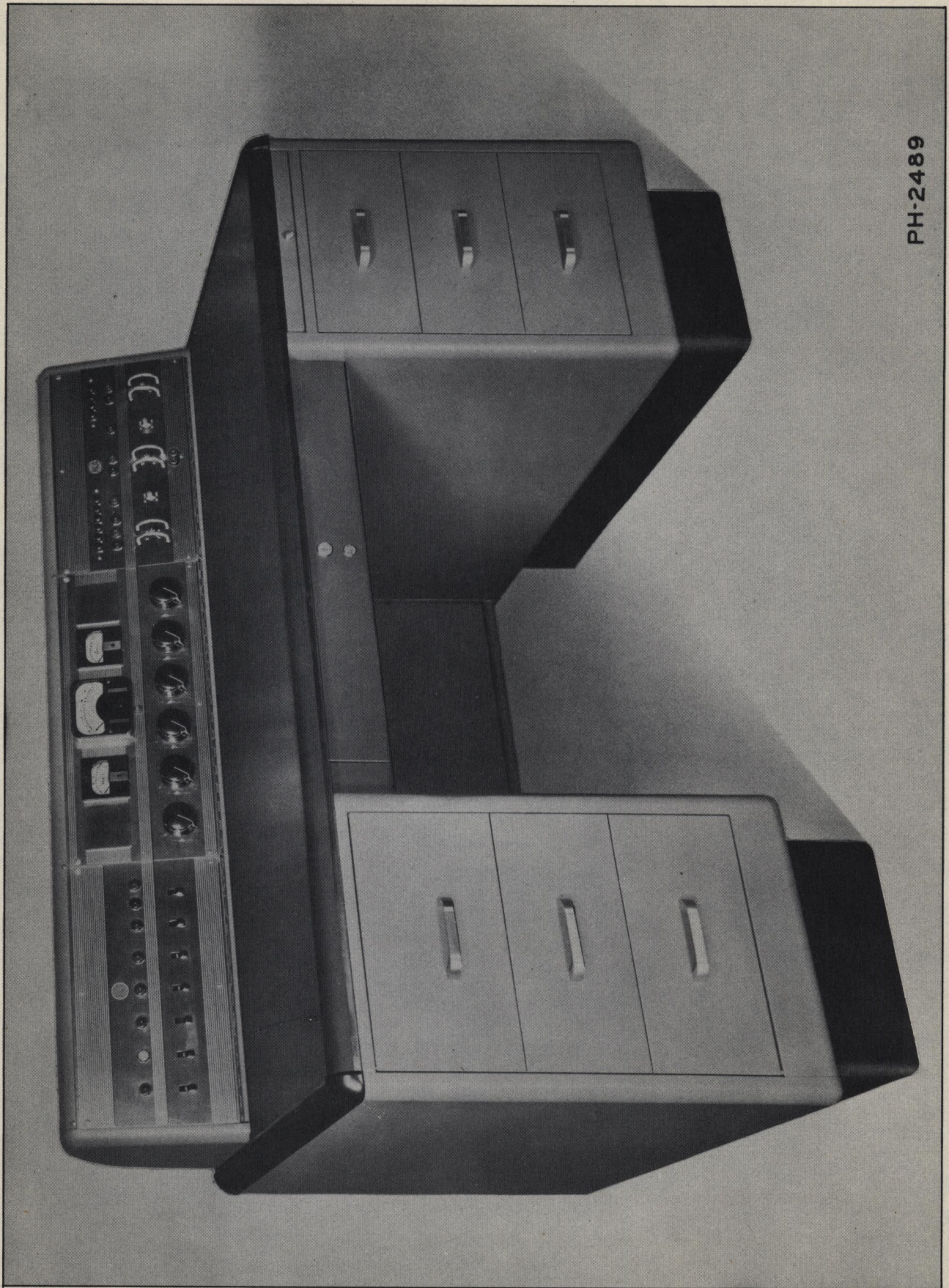

Figure 1—Transmitter Control Desk (Front View)

TABLE OF CONTENTS

Title	Page
Technical Summary	2
Electrical Characteristics	2
Mechanical Specifications	3
Equipment	3
Description	4
General	4
Circuit Functions	4
Metering Circuits	4
Monitoring Circuits	4
Incoming Lines Circuits	5
Local Transcription—Turntable Circuits	5
Local Microphone Circuit	5
Power Switch Circuits	6
Installation	6
Location	6
Wiring	6
Audio Connections	9
Relay Power Supply	10
Operation	10
Maintenance	10
Parts List	11

ILLUSTRATIONS

Figure	Page
1 — Transmitter Control Desk (Front View)	ii
2 — TT to Type BA-1A Pre-Amplifier Interconnections (K-893495)	5
3 — Transmitter Control Desk (Rear View, Turret Cover Removed)	13
4 — Transmitter Control Desk (Front View, Panels Tilted Open)	14
5 — Transmitter Control Desk, Simplified Schematic (P-170809)	15
6 — Transmitter Control Desk Connections (WW-130092)	16
7 — Relay Power Supply, Schematic (K-182159)	17
	1

TECHNICAL SUMMARY

Electrical Characteristics

Power Required (lamps and relays)..... 105-125 volts, 50-60 cycles, 25 watts

Input Impedances:

Lines 1 and 2..... 600 ohms, balanced
Telephone Set..... 600 ohms
Studio, Master and Monitor Controls..... 600 ohms, balanced
Microphone and Turntable..... 250 ohms, balanced
VU Meter..... 7500 ohms
Monitor—Transmitter, in and out..... 10,000 ohms to 20,000 ohms
Monitor—Lines 1 and 2..... 20,000 ohms
Monitor Speaker Relay..... 15 ohms

Output Impedances:

Lines 1 and 2..... 600 ohms
Microphone and Turntable Mixer Circuit..... 600 ohms, balanced
Studio, Master and Monitor Controls..... 600 ohms, balanced
Microphone and Turntable Controls..... 250 ohms to 500 ohms

Frequency Response ± 0.1 db, 30 to 15,000 cycles

Insertion losses (microphone and turntable mixer circuit)..... 7 db

Volume Controls:

Studio Control: 600 ohms; 20 steps, 2 db per step, last step infinite, linear; insertion loss 6 db; balanced.

Master Control: 600 ohms to 600 ohms; 20 steps, $\frac{1}{2}$ db per step, last step infinite, linear; insertion loss 6 db; balanced.

Monitor Control: 600 ohms to 600 ohms; 2 db per step, last step infinite, tapered; insertion loss 6 db; balanced.

Microphone and Turntable Controls: 250-500 ohms; 2 db per step, last step infinite, tapered; insertion loss 2 db; balanced.

Volume Indicator Control: 3900-7500 ohms; 2 db per step, linear; insertion loss 0 db.

VU Rheostat: 800 ohms; 10 steps, 0.1 db per step, linear.

Monitor Bridging Controls: 10,000 ohms dual carbon potentiometers, balanced.

Noise Level: Circuits are isolated so that residual noise will not exceed the aggregate noise level of the associated amplifiers:

Relay Power Supply:

Power Supply..... 105-125 volts, 50-60 cycles

A-C Line Fuse 0.5 ampere

Power Output (d-c)..... 12 volts at 1 ampere

Ripple Voltage..... 0.75 volt maximum

Mechanical Specifications

Dimensions:

Width	60 inches
Depth	34½ inches
Height (Turret extends approximately 11 inches above desk top).....	30½ inches
Weight	393 pounds

EQUIPMENT

The equipment supplied with this Transmitter Control Desk is as follows:

Quantity	Item	
1	Transmitter Control Desk.....	MI-11616

The following equipment is recommended and may be obtained on separate order:

- 1 Transmitter Monitor and Amplifier Rack (for 60 c.p.s., MI-11620-E, for 50 c.p.s., MI-11620-G).
including:
 - 1 Type 9AX Cabinet Rack
 - 1 Type 66-D Modulation Monitor (including tubes)
 - 1 Type 86-A1 Limiting Amplifier (including tubes), MI-11216-C
 - 1 Type BA-4A, MI-11223, or Type BA-4B, MI-11223A, Monitoring Amplifier
 - 2 Type 33-A Jack Strips with Mat, MI-11501-A
 - 4 Type 36-B Panel and Shelf Assemblies
 - 3 Type BA-1A Pre-Amplifiers, MI-11218-A
 - 1 Type BX-1A, MI-11305, or Type BX-1B, MI-11305-A Power Supply
 - 2 Type 56-C Line Equalizers
 - 3 Line Coils, MI-4900-A
 - 1 Type 57-C Switch and Fuse Panel
 - 2 "J" Strips, MI-4537-D
 - 1 Sola Regulator
 - (60 c.p.s. unit supplied with MI-11620-E), MI-11280
 - (50 c.p.s. unit supplied with MI-11620-G), MI-11280-G.

NOTE: If two-power operation is required, one Audio Relay Panel, MI-4309-B must be obtained.

DESCRIPTION

GENERAL

The Transmitter Control Desk, MI-11616 has been designed for use with a broadcast transmitter to provide a complete and flexible system of control in one console. It contains all of the mixing and switching facilities required at the transmitter station, and is equipped with a standard VU meter, an extension modulation monitor meter, and an extension antenna current meter.

It consists of a turret-type assembly mounted on top of a metal desk. All controls, switches, and meters are mounted on three panels which are hinged at the bottom so that they may be opened forward for convenient servicing. These panels are mounted in the turret top. The entire rear cover of the turret may be removed to facilitate installation or basic changes.

The desk and turret are of metal construction. The left-hand pedestal contains a typewriter shelf, and the right-hand pedestal contains two convenient drawers. A third drawer is located between the two pedestals. Metal skirts have been provided below the pedestals to conceal the wiring conduits. All wiring is carried inside the desk.

All a-c power switches and associated indicator lamps are mounted on the left-hand panel. The three meters and six attenuator controls are mounted on the middle panel. The monitor and VU meter, push-button switches, together with the audio lever switches, and the associated indicator lamps are mounted on the right-hand panel. Chromium plated guards prevent accidental operation of the most important lever switches ("LINES-IN," "TRANSMITTER ON," and "STUDIO-LOCAL").

Power is supplied to the monitor loudspeaker relay and audio indicator lamps from a 12 volt d-c power supply which is contained in the control desk. It is designed to operate from a power supply of 105-125 volts at from 50 to 60 cycles.

CIRCUIT FUNCTIONS

The electrical circuits of the Control Desk are detailed in Figure 6. For purposes of description Figure 6 may be considered as six separate groups of inter-related circuits: (a) metering circuits, (b) monitoring circuits, (c) "LINES-IN" circuits, (d) local transcription—turntable circuit, (e) local microphone circuit, and (f) power switching circuits. A description of the function of each of these circuits and of the component parts as well as the inter-relationships of the different circuits to each other follows:

METERING CIRCUITS

The Control Desk is equipped with a standardized VU meter, 9M2. Mechanically interlocked push-button switches 9S4 permit instantaneous selection of the circuit into which it is desired to insert the VU meter. Jacks "A" and "B" may be connected to any desired circuit by means of switches. The "TRANS-

IN" push button is connected so as to read the level of the audio current being fed to the modulator unit of the transmitter.

A step-by-step control marked "VI" (9A6) is connected in the volume indicator circuit making it possible to read levels of +4 db to +40 db at a reference level of 1 milliwatt. A step marked 1 mw is included for reference purposes.

A vernier control, 9R35, is mounted beneath the VU meter. This control may be adjusted so as to vary the meter indication ± 0.5 db so as to compensate for small differences in pointer indications when this meter is used in conjunction with one or more VU meters in any one network.

The antenna current indicator 9M3 is connected directly to terminals 51 and 52 of the terminal board behind the Attenuator and Meter Panel. These terminals should be connected to the rectified carrier circuit of the transmitter. The meter consists of a 0-50 ma, d-c movement with a scale of 50 divisions calibrated linearly from 0 to 10 amperes (r-f). It is calibrated especially for use on a steel panel one-eighth inch thick.

The modulation meter 9M1 is connected directly to terminals 53 and 54 of the terminal board behind the Attenuator and Meter Panel. This meter is intended to operate as an extension meter from the station modulation monitor.

Two spare meter positions are wired to terminals 49 and 50, and 55 and 56. An extension db gain reduction meter and an extension frequency monitor may be used in these positions if desired.

MONITORING CIRCUITS

The Control Desk contains equipment designed to bridge and monitor the following circuits: line 1 or line 2; transcription turntable; transmitter input; and transmitter output. Any one of these circuits may be selected instantly by means of the mechanically interlocking switches of the push-button switch assembly 9S15.

Incoming line 1 (L1) is connected through terminals 69 and 70 and the "LINE 1" push-button switch to the monitoring circuit. Line 2 (L2) is connected through terminals 75 and 76 and the "LINE 2" push-button switch to the monitoring circuit. Connections between the four line terminals (69 and 70, and 75 and 76) are made to the program lines at the jack strip of the station patching panel.

When either one of the two line push buttons are depressed the signal from the selected line will be connected through a bridging transformer (9T2) and the "TT-CUE" switch to the "MONITOR" volume control (9A7) and thence to terminals 79 and 80. The latter terminals should be connected through the jack strip of the station patching panel to the monitor amplifier input. The monitor amplifier output should be connected through the station patching panel to terminals 125 and 126. From these terminals the signal

is fed through the speaker relay (9E1) to terminals 127 and 128 which should be connected to the monitor speaker voice coil.

The "TT-CUE" push-button switch is connected through a bridging potentiometer, 9R32, to terminals 13 and 14. These terminals may be connected across the turntable line terminals 9 and 10. When the "TT-CUE" push button is depressed the signal from the turntable line is connected through the bridging potentiometer to the "TT-CUE" push-button switch and from here to the monitor speaker as described in the preceding paragraph.

The transmitter input is connected to the monitoring circuit by connecting terminals 63 and 64 to terminals 71 and 72. The "TRANS.-IN" push-button switch is connected through a bridging potentiometer, 9R33, to terminals 71 and 72. When this push button is depressed the transmitter input will be connected to the monitor speaker in the manner previously described.

The transmitter output is connected to the monitoring circuit by connecting the output of the antenna monitor rectifier to terminals 73 and 74. The "TRANS.-OUT" push-button switch is connected through a bridging potentiometer, 9R34. When the push button is depressed the transmitter output will be connected to the monitor speaker as described previously.

The bridging potentiometers may be adjusted so that the transmitter input may be compared to the transmitter output at the same audio level. A 600-ohm loading resistor should be connected across the "TRANS.-OUT" line if it has been designed to work into a 600-ohm load. The bridging potentiometers have input impedances of 10,000 ohms each.

The "OFF" push-button switch simply disconnects the monitor circuit from all lines.

INCOMING LINES CIRCUITS

Under normal conditions line 1 (L1) will be connected through the jack strip of the station patching panel to a repeating coil and from there to terminals 31 and 32 of the Control Desk. Likewise line 2 (L2) would be connected at the Control Desk to terminals 29 and 30. If line equalizers are used they should be connected across the jack strip ahead of the repeater coils. The patching panel, repeater coils, and line equalizers are all part of the accessory equipment recommended in the Equipment Table.

The incoming lines are connected to the "LINES-IN" switch 9S13 in such a way that when it is in the middle position both lines are disconnected and the red pilot lamp indicates "OFF." When the switch is in the "1" position, line 1 is connected through the "STUDIO" mixer control 9A5, while line 2 is connected to a telephone jack. From the "STUDIO" mixer control, line 1 passes through the "STUDIO-LOCAL" switch 9S9. If the latter is set in the "S" position, line 1 passes through the limiting amplifier (optional) to the "MASTER" volume control 9A2 and the "TRANS.-ON" switch 9S11 to the input of the transmitter. When the "LINES-IN" lever switch is set to position "2," the functioning of the lines is reversed.

With the "TRANS.-ON" lever switch in the "ON" position, a green pilot lamp (marked "ON") should light. When the switch is in the "OFF" position, a red pilot lamp should be illuminated.

LOCAL TRANSCRIPTION—TURNTABLE CIRCUITS

A transcription turntable (TT) may be connected through a pre-amplifier (accessory equipment) to the Control Desk at terminals 9 and 10. From this point the turntable line passes through the "TT" mixer control 9A3 to the "TT-OSC." lever switch 9S10. When this switch is in the "TT" position the line is connected through various items of accessory equipment consisting of an impedance matching transformer, a booster amplifier, and a matching pad to the "STUDIO-LOCAL" switch 9S9. When this switch is in the "LOCAL" position the turntable line is connected through the limiting amplifier (accessory equipment), master control and "TRANS.-ON" switch to the transmitter.

The transcription turntable should be connected to the type BA-1A pre-amplifier as indicated in Figure 2.

TYPE BA-1A PRE-AMPLIFIER

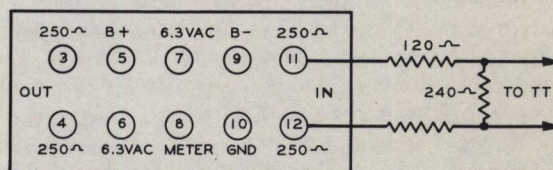

NOTE: MOVE CONNECTION FROM T-1 TERMINAL 7 TO TERMINAL 1.

Figure 2—TT to Type BA-1A Pre-Amplifier Interconnections (K-893495)

In the "S" position of the "STUDIO-LOCAL" switch a green pilot lamp (marked "S") should light. In the "L" position of this switch the red pilot lamp (marked "L") should be illuminated.

If desired, an audio oscillator (accessory equipment) may be connected through the station patching panel to terminals 39 and 40, which are wired to the "TT-OSC." switch. With this switch in the "OSC." position the audio oscillator is connected through to the transmitter input the same as described for the turntable except that the "TT" mixer control is not in the circuit.

When the "TT-OSC." switch is in either position the yellow pilot lamp should be illuminated.

LOCAL MICROPHONE CIRCUIT

Microphones (1 or 2) may be connected through to the input of the transmitter in exactly the same way as described for the turntable, except that the microphone switch "MIC." (9S12) should be used instead of the "TT-OSC." switch.

A red pilot light located above the "MIC." switch indicates when the switch is thrown to either position 1 or 2.

The speaker relay coil (accessory equipment) is interlocked with the "MIC." lever switch, and is energized when the switch is in the center position. With the switch in either position 1 or 2 the relay coil is de-energized, the speaker is disconnected, and a 15-ohm resistor load is connected across the output of the amplifier. This arrangement prevents feedback howl which would occur if the microphone and speaker were on simultaneously.

POWER SWITCH CIRCUITS

All power switches are wired directly to the terminal board behind the left-hand panel. They should be connected into their respective circuits and used as follows:

The "AUDIO POWER" switch (9S8) is wired to terminals 89, 90, 91 and 92 and controls the 115-volt, 60-cycle supply to the auxiliary equipment in the speech rack, making it possible to control that equipment from the Control Desk as desired. A red pilot light (125 volts) operates in conjunction with this switch.

A "SPARE" switch (9S7) is wired to terminals 95, 96, 97 and 98 and is provided to be used as desired, depending upon the particular installation. A white pilot light (125 volts) wired to terminals 93 and 94 is provided to operate in conjunction with this switch.

The "TOWER LIGHTS" switch (9S6) wired to terminals 101, 102, 103 and 104, is included for convenience in controlling the tower lights. A yellow pilot light (230 volts) operates in conjunction with this switch. If a multi-element antenna array is used it may be desirable to use this switch to control a small contactor rather than run the full power for all the towers through the Control Desk. Since the conditions in each station may vary considerably it is prefer-

able to locate the conduit from the floor channels to the tower lighting circuit in accordance with the particular station layout plans.

The "FILAMENT ON" switch (9S5) wired to terminals 115 and 116, should be connected in series with the filament switch of the exciter. Both switches must then be closed to operate the equipment, and the transmitter may be started or stopped at the Control Desk by means of this switch. The "FILAMENT" pilot light (red, 230 volts), wired to terminals 113 and 114, may be connected to indicate when power is applied to the filaments.

The "PLATE ON" switch (9S4) wired to terminals 111 and 112, should be connected in series with the rectifier switch on the power amplifier panel. Thus the plate supply may be turned on or off at the Control Desk. A red pilot light (230 volts) wired to terminals 109 and 110, should be connected to work in conjunction with this switch, and indicates when plate power is on.

The "OVERLOAD" switch (9S3) wired to terminals 83 and 84, is of the momentary contact type and normally is used in conjunction with a notching relay. If the notching relay has operated it may be reset by throwing the "OVERLOAD" switch to the "RESET" position. A yellow pilot light (230 volts) wired to terminals 81 and 82, should be connected to indicate when the relay operates.

The "POWER CHANGE" switch (9S2) wired to terminals 117, 118, 119, 121, 122, and 123, should normally be connected to the power control panel to control the plate voltage supply through relays. The common lead from a green pilot light ("LOW") and a red-pilot light ("HIGH") is wired to terminal 120.

CAUTION — The "POWER-CHANGE" switch should always be in the "LOW" position for the first application of power.

INSTALLATION

LOCATION

Since no two installations of this equipment will be exactly alike, the location of the Control Desk will depend mainly upon local conditions. The Control Desk will usually be mounted in front of the transmitter so that the operator, when seated at the desk, faces the transmitter meter panels. The rack of auxiliary equipment will usually be located off to the side. If a measuring equipment rack is used it will normally be placed alongside the rack of auxiliary equipment. The exact layout of equipment will depend upon the transmitter layout, architectural arrangement of the station, and other conditions surrounding the specific installation.

WIRING

All external wiring should be connected to the Control Desk through the three terminal blocks which are located inside the turret top assembly. The audio ter-

minal board (solder type) is located behind the meter panel assembly. Four power terminal boards are located behind the power switching panel and one behind the monitor switching panel assembly. Audio and power leads should be kept as far apart as possible at all times.

The control desk is designed so that the wiring may be brought up through the left rear side of the desk from a conduit junction box in the floor below. The metal skirt (or false base) around the bottom of the pedestal may be removed for wiring without lifting the desk from the floor. When installing the equipment the back rear cover of the turret assembly should be removed to facilitate wiring.

Connections to the terminal boards behind the two end panels may be made from the front, and connections to the audio terminal board should be soldered to terminals from the back. However, all circuits may be tested from the front.

The following table can be used as a reference when connecting the Control Desk, MI-11616 to external equipment. When a recommended equipment is to be

connected, the instruction book accompanying that equipment should be consulted for wiring to the respective terminal boards.

Terminal No.	Internal Connection	External Connection Recommended
1	Studio Attenuator Input	To terminals 33 and 34 through matching pad* if desired.
2	Studio Attenuator Input	To terminals 23 or 24.
3	Studio Attenuator Output	To terminals 24 or 23.
4	Studio Attenuator Output	To station patching panel jack strip* and pre-amplifier.*
5	Microphone Attenuator Input	To terminals 15 or 16.
6	Microphone Attenuator Input	To terminals 16 or 15.
7	Microphone Attenuator Output	To terminals 13 and 14; station patching panel and pre-amplifier.*
8	Microphone Attenuator Output	To terminals 19 or 20.
9	Turntable Attenuator Input	To terminals 20 or 19.
10	Turntable Attenuator Input	To terminals 9 or 10.
11	Turntable Attenuator Output	To terminals 10 or 9.
12	Turntable Attenuator Output	To terminals 7 or 8.
13	Turntable Bridging Potentiometer	To terminals 8 or 7.
14	Turntable Bridging Potentiometer	To station patching panel; impedance matching transformer*; booster amplifier.*
15	Microphone Switch (MIC. 1)	To terminals 11 or 12.
16	Microphone Switch (MIC. 1)	To terminals 12 or 11.
17	Mixer Circuit Output	To matching pad* and station patching panel jack strip.*
18	Mixer Circuit Output	To terminals 3 or 4.
19	Turntable "IN" Switch	To terminals 4 or 3.
20	Turntable "IN" Switch	To station patching panel jack strip.*
21	Studio-Local Switch ("L")	To station patching panel jack strip.*
22	Studio-Local Switch ("L")	To station patching panel jack strip.*
23	Studio-Local Switch ("S")	To station patching panel jack strip.*
24	Studio-Local Switch ("S")	To station patching panel jack strip.*
25	Studio-Local Switch (Local)	To station patching panel jack strip.*
26	Studio-Local Switch (Local)	To station patching panel jack strip.*
27	Studio-Local Switch (Common)	To station patching panel jack strip.*
28	Studio-Local Switch (Common)	To station patching panel jack strip.*
29	Line Switch (L2)	To station patching panel jack strip.*
30	Line Switch (L2)	To station patching panel jack strip.*
31	Line Switch (L1)	To station patching panel jack strip.*
32	Line Switch (L1)	To station patching panel jack strip.*
33	Line Switch (Common Output)	To terminals 1 and 2 through matching pad* if desired.
34	Line Switch (Common Output)	To station patching panel jack strip* and telephone set.*
35	Line Switch (Common Input)	To station patching panel jack strip* and telephone set.*
36	Line Switch (Common Input)	To station patching panel jack strip* and telephone set.*
37	Microphone Switch (MIC. 2)	Optional.
38	Microphone Switch (MIC. 2)	To station patching panel jack strip* and audio amplifier.*
39	TT-Osc. Switch (Osc.)	To station patching panel jack strip.*
40	TT-Osc. Switch (Osc.)	To station patching panel jack strip.*
41	Jack Switch "A"	To station patching panel jack strip.*
42	Jack Switch "A"	To station patching panel jack strip.*
43	Jack Switch "B"	To station patching panel jack strip.*
44	Jack Switch "B"	To station patching panel jack strip.*
45	Monitor Attenuator Common	To station patching panel jack strip.*
46	Studio Attenuator Common	To station patching panel jack strip.*
47	Mic.—TT Attenuator Common	To station patching panel jack strip.*
48	Master Attenuator Common	To station patching panel jack strip.*
49	Spare Meter	To limiting amplifier (optional). *DB gain reduction meter to be mounted in panel.
50	Spare Meter	To limiting amplifier (optional). *DB gain reduction meter to be mounted in panel.

Terminal No.	Internal Connection	External Connection Recommended
51	Antenna Current Meter	To rectified carrier circuit of transmitter.
52	Antenna Current Meter	
53	Modulation Meter	To station modulation monitor.
54	Modulation Meter	
55	Spare Meter	To frequency monitor.* Frequency meter to be installed in panel (optional).
56	Spare Meter	
57	Volume Indicator Meter	To volume indicator switching circuits.
58	Volume Indicator Meter	
59	Master Attenuator Input	To station patching panel jack strip.*
60	Master Attenuator Input	
61	Trans.-ON Switch (contact)	To transmitter modulator unit through jack strip* of station patching panel.
62	Trans.-ON Switch (contact)	
63	Trans.-ON Switch (arm)	To terminals 71 or 72, and 65 or 66.
64	Trans.-ON Switch (arm)	To terminals 72 or 71, and 66 or 65.
65	Master Attenuator Output	To terminals 63 or 64, and 71 or 72.
66	Master Attenuator Output	To terminals 64 or 63, and 72 or 71.
67	Turntable Cue Switch (Common)	To terminals 77 or 78.
68	Turntable Cue Switch (Common)	To terminals 78 or 77.
69	Monitor Switch (Line 1)	To station patching panel jack strip.*
70	Monitor Switch (Line 1)	
71	Trans.-IN—Bridging potentiometer	To terminals 63 or 64.
72	Trans.-IN—Bridging potentiometer	To terminals 64 or 63.
73	Trans.-OUT—Bridging potentiometer	To antenna monitor rectifier circuit.
74	Trans.-OUT—Bridging potentiometer	
75	Monitor Switch (Line 2)	To station patching panel jack strip.*
76	Monitor Switch (Line 2)	
77	Monitor Attenuator Input	To terminals 67 or 68.
78	Monitor Attenuator Input	To terminals 68 or 67.
79	Monitor Attenuator Output	Through station patching panel to monitor amplifier input.
80	Monitor Attenuator Output	
81	Overload Pilot Lamp	To overload circuit of transmitter.
82	Overload Pilot Lamp	
83	Overload Switch	To overload circuit of transmitter.
84	Overload Switch	
85	No Connection	
86	No Connection	
87	No Connection	
88	No Connection	
89	Audio Switch	To audio circuits to be controlled.
90	Audio Switch and Pilot Lamp	
91	Audio Switch	
92	Audio Switch and Pilot Lamp	
93	Spare Pilot Lamp	Any circuit.
94	Spare Pilot Lamp	
95	Spare Switch	Optional.
96	Spare Switch	Optional.
97	Spare Switch	Optional.
98	Spare Switch	Optional.
99	No Connection	
100	No Connection	
101	Tower Light Switch	To tower light electrical circuit.
102	Tower Light Switch and Pilot Lamp	To tower light electrical circuit.

Terminal No.	Internal Connection	External Connection Recommended
103	Tower Light Switch	To tower light electrical circuit.
104	Tower Light Switch and Pilot Lamp	To tower light electrical circuit.
105	No Connection	
106	No Connection	
107	No Connection	
108	No Connection	
109	Plate Pilot Lamp	
110	Plate Pilot Lamp	To plate supply circuit of transmitter.
111	Plate Voltage Switch	
112	Plate Voltage Switch	To plate voltage circuit of transmitter.
113	Filament Pilot Lamp	
114	Filament Pilot Lamp	To filament supply circuit of transmitter.
115	Filament Voltage Switch	
116	Filament Voltage Switch	To filament supply voltage of transmitter.
117	Hi-Low Power Switch (Common)	
118	Hi-Low Power Switch and Low Lamp	
119	Hi-Low Power Switch and High Lamp	
120	Pilot Lamp Common	To high voltage power control circuits of transmitter.
121	Hi-Low Power Switch (Common)	
122	Hi-Low Power Switch (Low)	
123	Hi-Low Power Switch (High)	
124	No Connection	
125	Monitor Speaker Relay	To station patching panel jack strip* and output of monitor amplifier.*
126	Monitor Speaker Relay	
127	Monitor Speaker Relay	To monitor speaker voice coil.*
128	(Contacts)	
129	A-C and D-C Voltage	
130	Terminal Board (A-C)	A-C Power Source.
131	MIC. 1 or 2 Pilot Lamp	+12 volts d-c.
132	Audio Switches Pilot Lamps (Com.)	-12 volts d-c.
133	Volume Indicator Pilot Lamps	+12 volts d-c.
134	Volume Indicator Pilot Lamps	-12 volts d-c.
135	MIC. 1 or 2 Pilot Lamp	+12 volts d-c.
136	Desk Ground	Station Ground.
137	Jack (9J1)	To pre-amplifier input.*
138	Jack (9J2)	To pre-amplifier input.*
139	Jack (9J1)	Optional.
140	Jack (9J2)	Optional.

NOTE: Items marked with an asterisk (*) are accessory equipment recommended in the Equipment Table.

Figure 5 shows the connections for a typical installation. As stated, care should be exercised that audio and power leads are not previously included in any one conduit running to, or from, the Control Desk.

AUDIO CONNECTIONS

The impedances of the various circuits are listed in the "Technical Summary." In order to match these circuits it is necessary that the auxiliary equipment be connected as follows:

The turntable microphone pre-amplifiers should each be connected for an output impedance of 250 ohms,

balanced. Pre-amplifier inputs must match the turntable and microphone output impedances respectively.

The booster amplifier must be connected for an input and output impedance of 500-600 ohms, balanced. When a Type BA-1A amplifier is used (as recommended) an MI-4900-A matching transformer should be connected into the input circuit.

The limiting amplifier must be connected to an input and output impedance of 500-600 ohms, balanced.

The monitor amplifier must be connected for an input impedance of 500-600 ohms, balanced, and an output impedance to match the voice coil impedance of the monitor speaker.

If an audio oscillator is used it must have an output impedance of 500-600 ohms.

If auxiliary equipment is used in which it is impossible to obtain the proper impedances, impedance matching pads or transformers should be used.

RELAY POWER SUPPLY

The line voltage should first be determined so that the proper tap on the primary of the transformer may be used. There are three taps provided, one each for 105-, 115- and 125-volt operation. The tap to be used should be soldered to the fuse panel and the two wires not used should have their ends taped or otherwise

insulated. The transformer should be connected for line voltages as follows:

Line Voltage	Transformer Tap	Primary Wire To Be Connected
Less than 110 volts.....	105	Blue
110-120 volts.....	115	Black-Red
More than 120 volts....	125	Red

A voltage control switch located on top of the chassis may be adjusted by means of a screwdriver. This will permit a regulation of the d-c terminal voltage over a range of 2 volts.

OPERATION

Switches found on the left-hand panel control the filament and plate power supplied to the transmitter making it possible to start and stop the transmitter at the Control Desk by closing or opening the "FILAMENT ON" and "PLATE ON" switches. When making adjustments to the transmitter the "POWER" switch should be set in the "LOW" position. To reset the notching relay which operates after an overload, the "OVERLOAD" switch should be thrown to the "RESET" position.

By means of the lever switches located on the center of the right-hand panel, the incoming lines, local

microphone, transcription turntable or audio oscillator may be selectively connected to the input of the transmitter. In a similar manner the transmitter input may be connected to the local control room or to the studio.

By means of the push-button switches which are located on the right-hand panel, the input or the output of the transmitter, line 1 or 2, or the transcription turntable may be connected to the monitoring circuit.

The volume indicator meter may be switched to jacks "A" or "B" or to the input of the transmitter by the "VI METER" switches located on the right-hand panel.

MAINTENANCE

This Control Desk has been designed to provide maximum ease of servicing and accessibility of component parts. Switches, meters and controls are mounted on the three front panels. These panels may be tilted forward on hinges, thus making all parts and terminal boards accessible from the front.

For any piece of equipment that is subject to continuous use, as is most broadcast equipment, a regular routine of inspection should be set up and followed in order to avoid time off the air resulting from noisy circuits caused by the accumulation of dirt on terminals, volume controls and switches, corroded plugs, etc.

Auxiliary equipment should be inspected and serviced regularly in accordance with the separate instructions supplied for that equipment.

Attenuator control contacts should be cleaned by applying "Davenoil" to the contacts, rotating the knob and, if any dark streaks appear, wiping off the contacts. Repeat this procedure until absolutely clean, then lubricate with a thin film of Davenoil included as part of this equipment. **IMPORTANT**—The Davenoil is provided for cleaning and lubricating the contacts of the attenuator controls, and no other clean-

ing agent such as carbon tetrachloride should be used.

As shipped from the factory the various key switch contacts have been properly adjusted to give the proper sequence of circuit connections when they are operated, so that, for instance, a local microphone and monitor speaker will not be on at the same time and because of this cause acoustic feedback when the "MIC." lever key is operated.

In case the "MIC." key switch is replaced, or if feedback trouble is encountered, the contacts should be adjusted, using a standard key switch or relay contact bending tool. When adjusting the switch the following desired sequence of operations should be kept in mind. The RELAY CONTACTS MUST OPERATE FIRST AND THE AUDIO CIRCUITS TRANSFER LAST. This is accomplished by relieving the tension of the center spring of the form D contacts controlling the relay and increasing the tension of the center spring of the form D contacts carrying audio. Care should be taken that the spring shape is not altered or the contact pressure reduced so much as to cause poor contact or short circuits.

Before replacing the 0.5 ampere line fuse which is located in the relay power supply, disconnect the source of power.

REPLACEMENT PARTS LIST

When ordering replacement parts, please give Symbol, Description, and Stock Number of each item ordered.

The part which will be supplied against an order for a replacement item may not be an exact duplicate of the original part, however, it will be a satisfactory replacement, differing only in minor mechanical or electrical characteristics. Such differences will in no way impair the operation of the equipment.

MAIN ASSEMBLY

Symbol No.	Description	Stock No.
9C3	Capacitor, 0.5 mfd., 200 volts	70619
9E1	Relay, 12-volt (monitor speaker)	16998
9R22	Resistor, 15 ohms, 10 watts	18236
9R32, 9R33, 9R34	Control, dual, 10,000 ohms, bridging potentiometer	44102
9T2	Transformer, bridging	MI-4901
	Spring, panel fastener, with mounting screws, nuts and lockwashers	44217
RELAY POWER SUPPLY		
9A1	Rectifier unit	44104
9C1, 9C2	Capacitor, 1000 mfd., 25 volts	18374
9F1	Fuse, 0.5 ampere, line	3748
9R1	Resistor, 120 ohms, 10 watts	44106
9S1	Switch, voltage regulator	44105
9T1	Transformer, 105-115-125 volts, 50/60 cycle, power	45965
	Holder, fuse	32059
	Plate, capacitor mounting	18469
POWER PANEL ASSEMBLY		
9A9	Pilot light, green, 250 volts	
9A10, 9A12, 9A13	Pilot light, red, 250 volts	
9A11, 9A14	Pilot light, yellow, 250 volts	
9A15	Pilot light, white, 125 volts	
9A16	Pilot light, red, 125 volts	
	Parts for Above	
	Cap, green	44136
	Cap, red	19897
	Cap, white	44135
	Cap, yellow	44137
	Lamp, 24 volts	16154
	Resistor, 125 volts	44131
	Resistor, 250 volts	44570
	Receptacle, less lamp, cap, and resistor	44997
9S2	Switch, "High-Low" power	21802
9S3	Switch, "Over-Load" reset	44107
9S4, 9S5	Switch, "Filament" or "Plate" control	44109
9S6	Switch, "Tower Lights" control	44108
9S7, 9S8	Switch, "Audio Power" or "Spare" control	25040
CONTROL PANEL ASSEMBLY		
9A2	Control, 600-600 ohm "Master" attenuator	44101
9A3, 9A4	Control, 250-500 ohm "Mic." or "TT" attenuator	44100
9A5	Control, 600-600 ohm "Studio" attenuator	44099

REPLACEMENT PARTS LIST (Continued)

Symbol No.	Description	Stock No.
9A6	Control, "Meter" attenuator	44092
9A7	Control, 600-600 ohm "Monitor" attenuator	44097
9M1	Meter, modulation	44110
9M2	Meter, V. U.	43186
9M3	Meter, 0-10 ampere, antenna	19889
9R35	Control, meter rheostat	44098
	Knob, control	17369
LINE SWITCH PANEL ASSEMBLY		
9A17, 9A21, 9A24 9A18, 9A20, 9A22, 9A25 9A19, 9A23	Pilot light, green Pilot light, red Pilot light, yellow	
	Parts for Above	
	Cap, green	44136
	Cap, red	19897
	Cap, yellow	44137
	Lamp, 12 volt	21332
	Receptacle, less cap and lamp	44997
9J1	Jack, closed circuit, less mounting strip	51576
9R2 to 9R16	Resistor, 560 ohms, 1/2 watt	5164
9R17, 9R18, 9R19, 9R20	Resistor, 56 ohms, 1/2 watt, wire-wound	44095
9R21	Resistor, 600 ohms, 1 watt	44274
9R23, 9R24, 9R25	Resistor, 8200 ohms, 1/2 watt	14250
9R26, 9R27, 9R28, 9R29	Resistor, 22,000 ohms, 1/2 watt	30492
9R30, 9R31	Resistor, 125 ohms, 1/2 watt, wire-wound	44096
9S9, 9S13	Switch, key (used for "LINES" and "STUDIO-LOCAL" switching)	18291
9S10, 9S11, 9S12	Switch, key (used for "MIC," "TRANS," and "TT-OSC" switching)	17015
9S14	Switch, 4-button, push	44094
9S15	Switch, 6-button, push	44093
	Support, fall (for panel)	44216

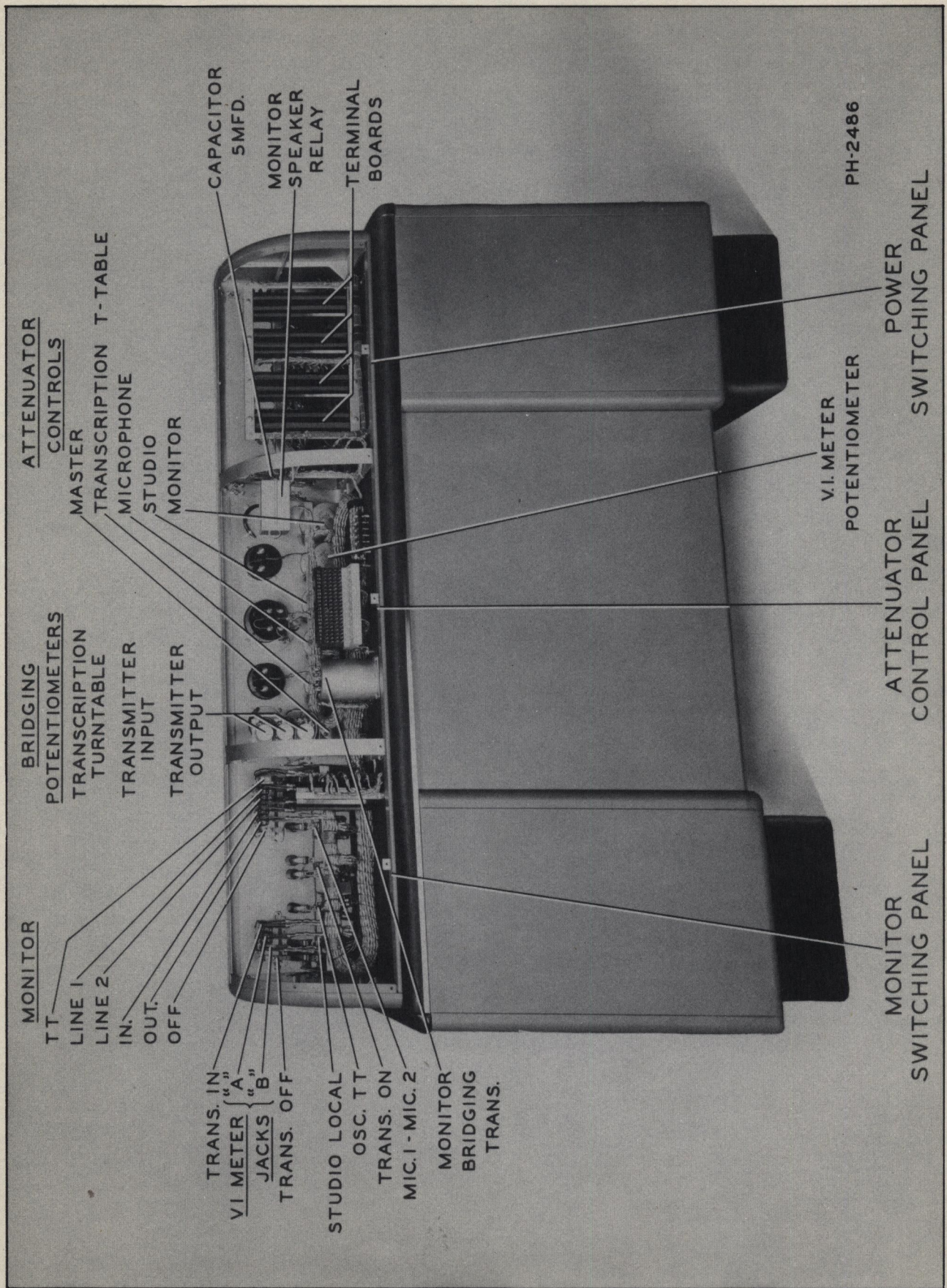

Figure 3—Transmitter Control Desk (Rear View, Turret Cover Removed)

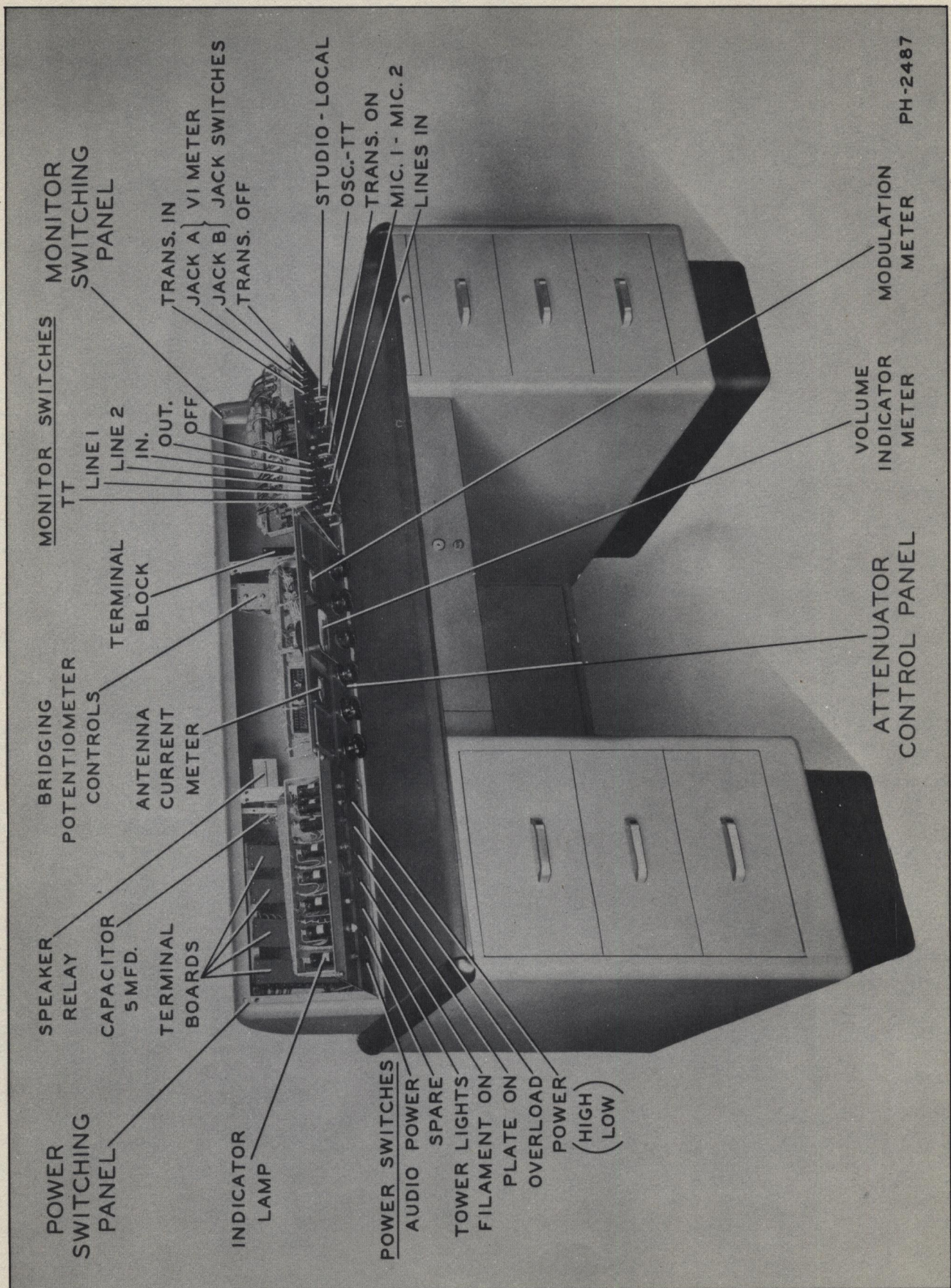

Figure 4—Transmitter Control Desk (Front View, Panels Tilted Open)

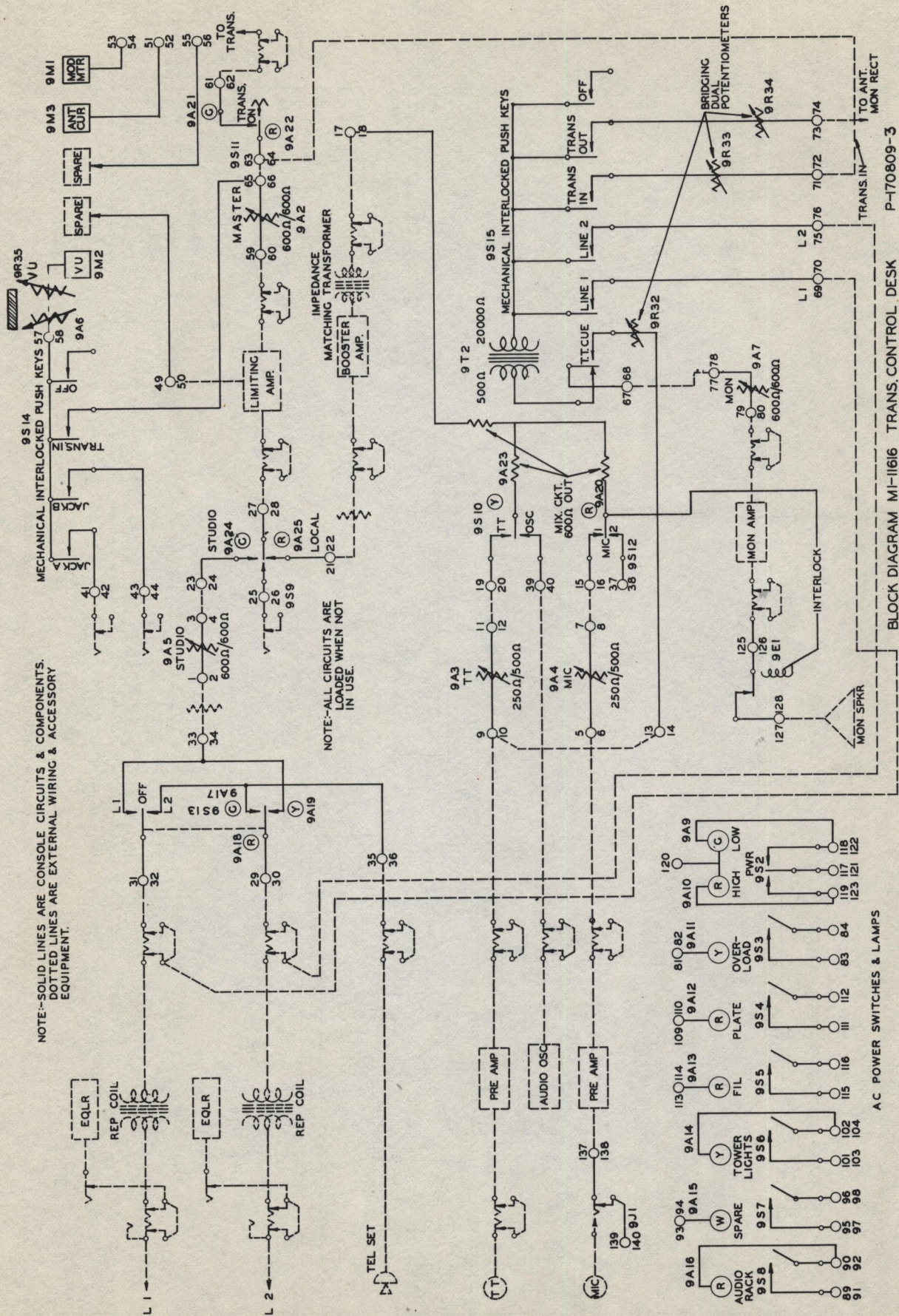
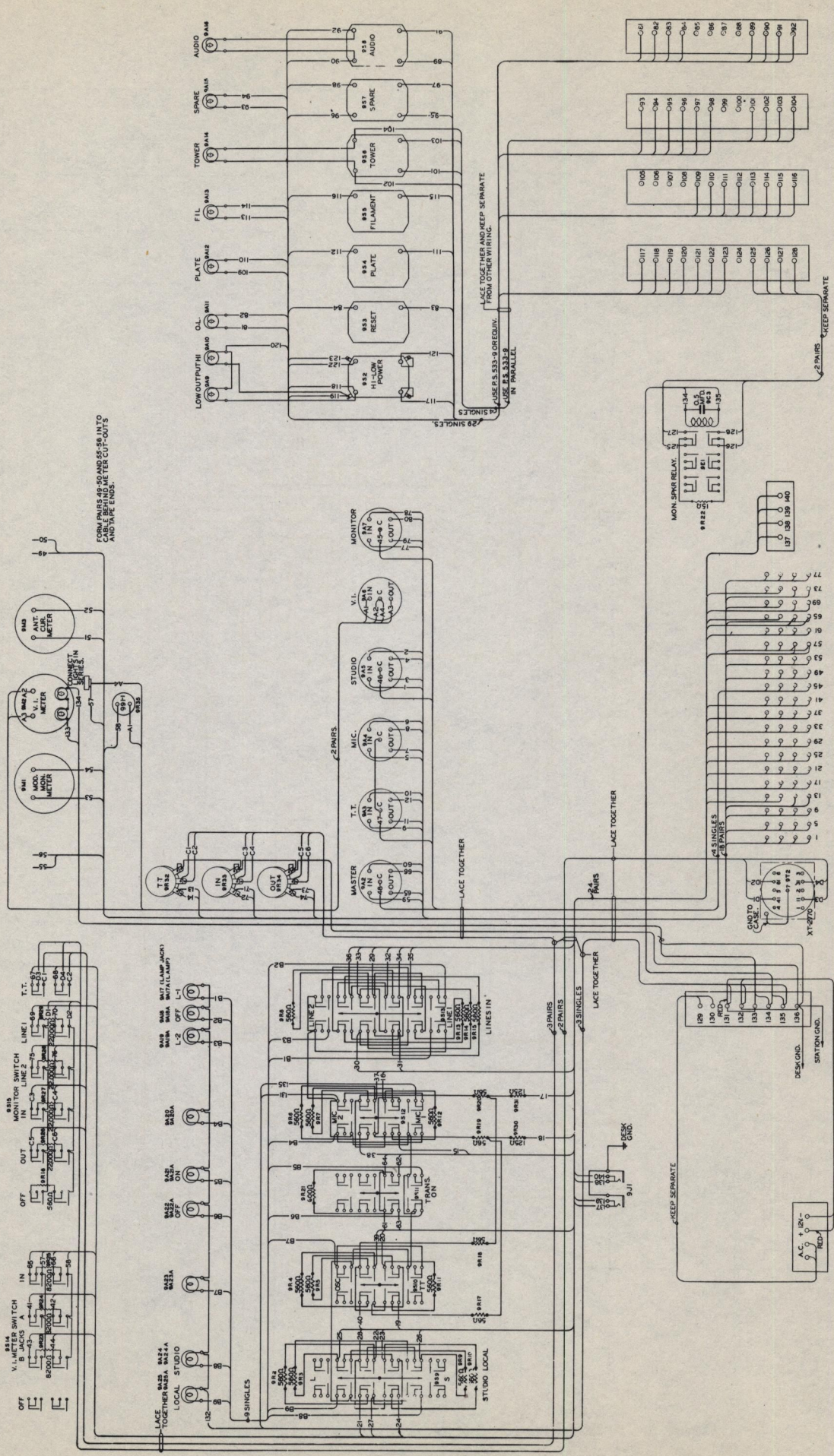

Figure 5—Transmitter Control Desk, Simplified Schematic (P-170809)

PANEL NO. 1

PANEL NO. 2

PANEL NO. 3



ALL WIRING NOT OTHERWISE MARKED IS PAIRS K-832483-3 SINGLES M-140182-6

WW-130092-9

MI-11616

REAR VIEW OF PANELS

Figure 6—Transmitter Control Desk Connections (WW-130092)

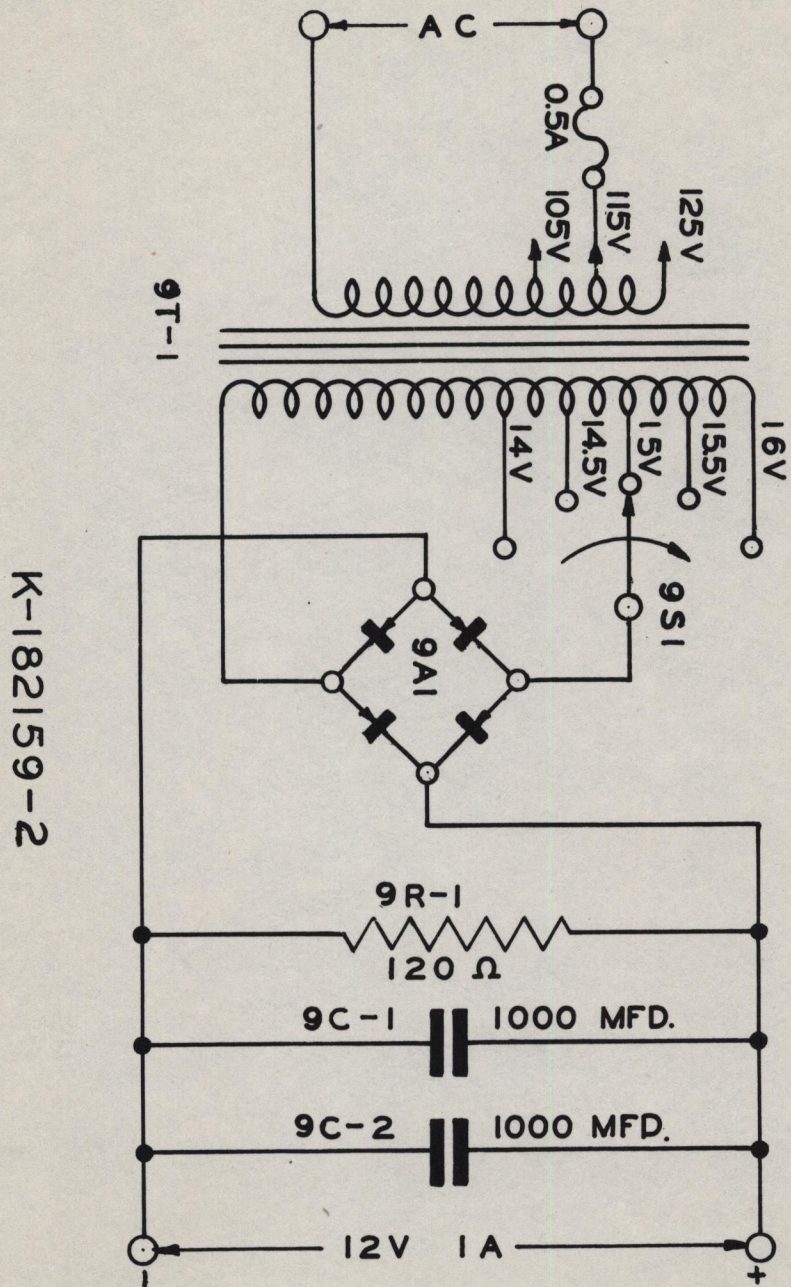

Figure 7—Relay Power Supply, Schematic (K-182159)