



AN EXCLUSIVE RADIO SHACK SERVICE TO THE EXPERIMENTER

### SN76477N COMPLEX SOUND GENERATOR

#### DESCRIPTION:

The SN76477N Complex Sound Generator is a linear/1<sup>2</sup>L device which provides noise-, tone- or low-frequency - (or a combination of these) based complex sounds. Programming is via external components, (user-selected), which allows a wide variety of sounds to be created. The SN76477N is designed for ultimate flexibility in user-defined sounds, and may be used in any application requiring audio feedback to the operator (i.e. arcade/home video games, pinball games, toys, etc.; consumer oriented equipment, such as timers, alarms, controls, etc.; industrial equipment for indicators, alarms, feedback controls, etc.).

If You Didn't Get This From My Site,  
Then It Was Stolen From...  
[www.SteamPoweredRadio.Com](http://www.SteamPoweredRadio.Com)

#### OUTLINE DIMENSIONS

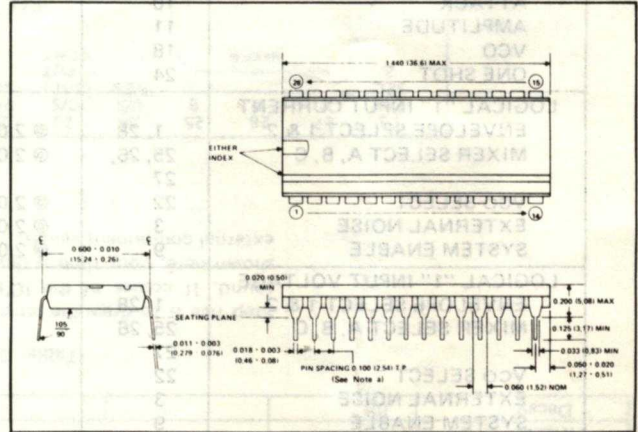

#### FEATURES

- Generates Noise, Tone or Low-Frequency-Based Sounds, or Combination of These
- Allows Custom Sounds to be Created Easily
- Low Power Requirements
- Allows Multiple-Sound Systems
- Compatible With Microprocessor Systems

#### ABSOLUTE MAXIMUM RATINGS AT TA = 25°C (UNLESS OTHERWISE SPECIFIED)

Supply Voltage, VREG, Pin 15	6.0V
Supply Voltage, VCC, Pin 14	12.0V
Input Voltage Applied to any Device Terminal	6.0V
Operating Temperature Range	-55°C to +120°C
Lead Temperature 1/16 Inch From Case For 10 Seconds	+260°C

#### RECOMMENDED OPERATING CONDITIONS

	MIN.	TYP	MAX	UNITS
Supply Voltage, VREG, Pin 15	4.5	5.0	5.5	V
Supply Voltage, VCC, Pin 14	7.5		9.0	V
Operating Free-Air Temperature	0	25	70	°C

#### DUAL-IN-LINE PACKAGE (TOP VIEW)

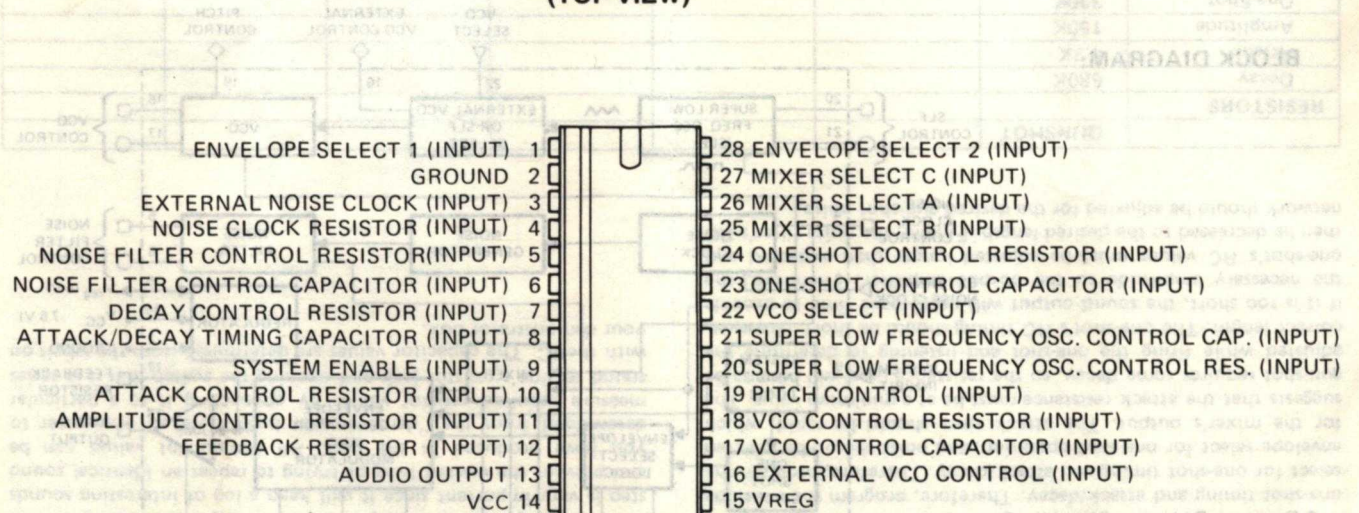

OPERATING CHARACTERISTICS AT TA = 25°C AND VREG = 5.0V

PARAMETER	PIN	CONDITIONS	MIN	TYP	MAX	UNITS
ICC	14	VREG = 5.0V; NO EXT. LOAD		15	40	mA
VREG	15	VCC = 8.25V; ILOAD = 10mA	4.5		5.5	V
INPUT REGULATION	15	ILOAD = 10mA VCC = 7.5V TO 9.0V		150		mV
CONTROL INPUT CURRENT RANGE			1		200	uA
NOISE CLOCK	4					
NOISE FILTER	5					
DECAY	7					
ATTACK	10					
AMPLITUDE	11					
VCO	18					
ONE SHOT	24					
LOGICAL "1" INPUT CURRENT						
ENVELOPE SELECT 1 & 2	1, 28	@ 2.0V		40	52	uA
MIXER SELECT A, B, C	25, 26, 27	@ 2.0V		40	52	uA
Vco SELECT	22	@ 2.0V		40	52	uA
EXTERNAL NOISE	3	@ 2.0V		40	52	uA
SYSTEM ENABLE	9	@ 2.0V			100	uA
LOGICAL "0" INPUT VOLTAGE			2.0			V
ENVELOPE SELECT 1 & 2	1, 28					
MIXER SELECT A, B, C	25, 26, 27					
Vco SELECT	22					
EXTERNAL NOISE	3					
SYSTEM ENABLE	9					
LOGICAL "0" INPUT VOLTAGE					0.8	V
ENVELOPE SELECT 1 & 2	1, 28					
MIXER SELECT A, B, C	25, 26, 27					
Vco SELECT	22					
EXTERNAL NOISE	3					
SYSTEM ENABLE	9					
EXTERNAL Vco CUTOFF	16		2.5			V
TRIP POINTS				2.5		V
ONE-SHOT CAP	23					
Vco CAP	17					
NOISE FILTER CAP	6					
SLF CAP	21					
MAXIMUM PEAK-TO-PEAK OUTPUT VOLTAGE SWING	13	RLOAD = 10K RFDBK = 10K I11 = 200uA	2.5			V
DYNAMIC OUTPUT IMPEDANCE	13			100		OHMS

BLOCK DIAGRAM:

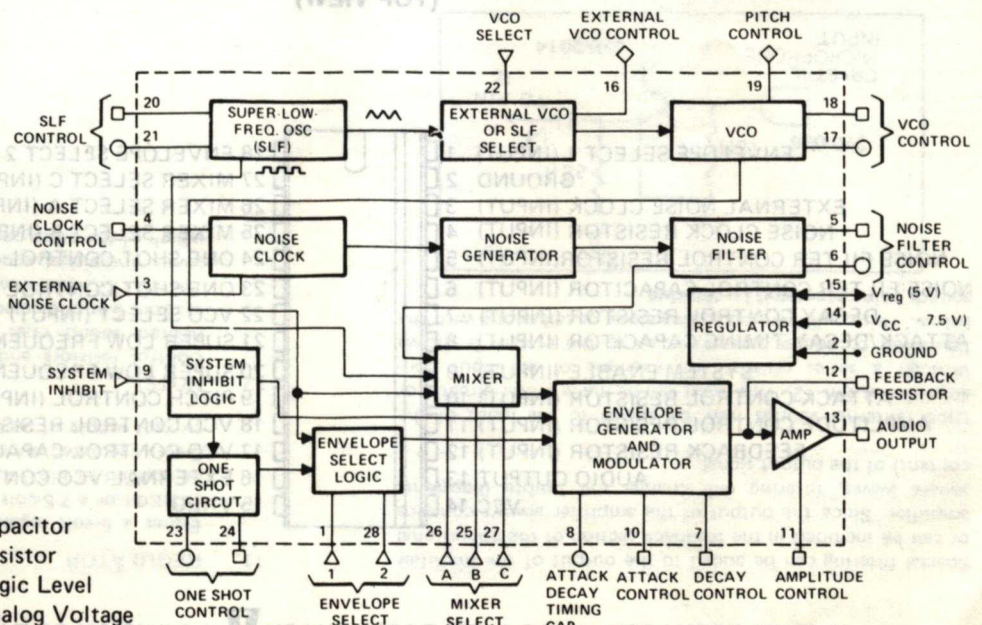

- Denotes Programming Via Capacitor
- Denotes Programming Via Resistor
- △ Denotes Programming Via Logic Level
- ◇ Denotes Programming Via Analog Voltage

# OPERATION

## 1. SLF (SUPER LOW FREQUENCY OSCILLATOR)

The SLF is normally operated in the range of 0.1 – 30 Hz, but will operate up to 20 kHz. The frequency is determined by the SLF control resistor (Pin 20) and capacitor (pin 21) according to the following equation:

$$\text{SLF Frequency (Hz)} \approx \frac{0.64}{R_{SLF} C_{SLF}} \quad @ V_{REG} = 5.0V$$

Equation 1: SLF Frequency Equation

The SLF feeds a 50% duty cycle square wave to the "mixer"; it also feeds a triangular wave to the "ext. VCO/SLF Select" logic, which is fed through to control the VCO when Pin 22 is high (see further explanation below).

## 2. VCO (VOLTAGE CONTROLLED OSCILLATOR)

The VCO circuitry produces a tone output whose frequency is dependent upon the voltage at the input of the VCO. The higher Pin 16 voltage is, the lower the frequency. The controlling voltage may be either the SLF output, or it may be an externally applied signal on Pin 16. The selection of control modes (external – Pin 16; internal – SLF) is via the binary logic level on Pin 22, VCO Select, according to the following table:

Pin 22	Control Mode
0	External (Pin 16)
1	Internal (SLF)

Table 1: VCO Control Mode Selection

The input at the External VCO Control, Pin 16, may be a DC voltage, (producing a constant tone at the output of the VCO), or any waveform, producing a frequency modulated output from the VCO. A frequency modulated waveform also results when the SLF ramp controls the VCO (Pin 22 = high), as shown below:

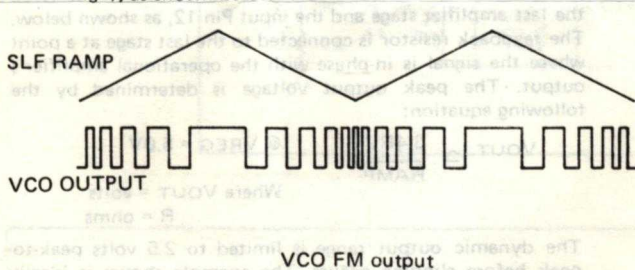

An alternate method to apply an external voltage to the VCO input is to place the controlling voltage on the SLF Control Capacitor Pin (Pin 21). In some applications this may be more convenient than using the Pin 16 input. The frequency Range of the VCO is internally determined at an approximate ratio of 10:1. The minimum frequency of the VCO may be determined by adjusting the RC time-constant of the VCO Control Resistor (Pin 18) and the VCO Control Capacitor (Pin 17), according to the following equation:

$$\text{Min VCO Freq. (Hz)} \approx \frac{0.64}{R_{VCO} C_{VCO}} \quad @ V_{REG} = 5.0V$$

Equation 2: Minimum VCO Frequency

The Pitch Control (Pin 19) varies the duty cycle of the VCO output according to the following equation:

$$\text{VCO Duty Cycle} \approx 50 \times \frac{\text{Voltage at Pin 16}}{\text{Voltage at Pin 19}} \%$$

Equation 3: Pitch Control of VCO Duty Cycle

By leaving Pin 19 high, a constant 50% duty cycle may be achieved. The specific % duty cycle, applies to constant tones produced by applying a constant DC voltage at the External VCO Control Pin (Pin 16). However, the Pitch Control may still be used to aesthetically alter the pitch of any frequency-modulated VCO output signals.

## 3. NOISE CLOCK

The Noise Clock clocks the Noise Generator. This circuit requires a 43K resistor to ground at Pin 14 to set an internal current level. An external noise clock may be supplied at Pin 3 to allow generation of lower frequency noise. This external clock should be a maximum 5 volt peak-to-peak square wave.

## 4. NOISE GENERATOR/FILTER

The Noise Generator is a binary psuedo random white noise generator whose output passes through the Noise Filter before being inputed to the mixer. The filter is a variable band width low-pass filter whose 3dB point is defined by the following equation:

$$\text{3dB Frequency (Hz)} \approx \frac{1.28}{R_{NF} C_{NF}} \quad @ V_{REG} = 5.0V$$

Equation 4: Noise Waveform 3 dB Frequency

5. The Mixer Logic selects one, (or a combination), of the inputs from the generators and feeds the output to the Envelope Generator and Modulator.

C (Pin 27)	Mixer Select			Mixer Output
	B (Pin 25)	A (Pin 26)		
0	0	0	0	VCO
0	0	0	1	SLF
0	1	0	0	Noise
0	1	1	1	VCO/Noise
1	0	0	0	SLF/Noise
1	0	1	1	SLF/VCO/Noise
1	1	0	0	SLF/VCO
1	1	1	1	Inhibit

Table 2: Mixer Select Logic

## 6. SYSTEM ENABLE LOGIC

The System Enable Logic provides an enable/inhibit for the system output. The sound output is controlled according to the following table:

Pin 9	Output
0	Enabled
1	Inhibited

Table 3: System Enable Logic

This input also triggers the "one-shot" logic for momentary sounds, such as gunshots, bells and/or explosions. The "one-shot" logic is triggered by the negative-going edge. This may be accomplished by a momentary switch, or by a square wave input at Pin 9. Pin 9 must be held low for the entire duration of the one-shot sound (including attack and decay period). The one-shot logic is operable only when the proper Envelope Select Logic selection is made. (see Envelope Select Logic).

## 7. "ONE-SHOT" LOGIC

The duration of the "one-shot" is defined by the following equation:

$$\text{Duration (seconds)} \approx 0.8 R_{os} C_{os} \quad @ V_{REG} = 5.0V$$

Equation 5: One-Shot Duration

In Equation 5, ROS is the One-Shot Control Resistor (Pin 24) and COS is the One-Shot Control Capacitor (Pin 23). Maximum duration of the One-Shot is approximately 10.0 seconds. When the One-Shot is controlled by external logic, the One-Shot Control Resistor and Capacitor may be eliminated. Simply begin One-Shot with Pin 9 (system enable) and end cycle by taking Pin 23 (One-Shot Capacitor) high.

### 8. ENVELOPE SELECT LOGIC

The Envelope Select Logic determines the envelope that is applied to the mixer output according to the following table

Envelope Select 1	Envelope Select 2	Selected Function
Pin 1	Pin 28	
0	0	VCO
0	1	Mixer Only
1	0	One-Shot
1	1	VCO with Alternating Polarity

Table 4: Envelope Select Logic Output

### 9. ATTACK AND DECAY CONTROL

The Attack/Decay circuitry alters the rise and fall of the envelope. An example of a noise waveform utilizing the envelope generator under one-shot control is:

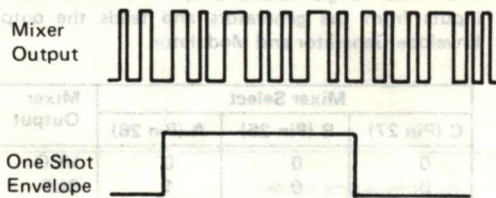

Figure 4: One-Shot Controlled Noise Waveform

By utilizing the Attack and Decay Control Inputs (Pin 7,10), the waveform may be affected in the following manner:

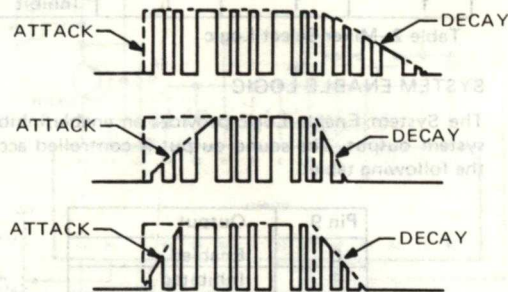

Figure 5: Examples of Varying Degrees of Attack and Decay on a Waveform

The amount of Attack and Decay is determined by the Attack Control Resistor (RA) (Pin 10) and the Decay Control Resistor (RD) (Pin 7) and the Attack Decay Timing Capacitor (CA-D) (Pin 18) According to the following equations:

$$\begin{aligned} \text{Attack Time (seconds)} &\approx RA \cdot CA-D \\ \text{Decay Time (seconds)} &\approx RD \cdot CA-D \\ &\text{@ VREG} = 5.0V \end{aligned}$$

### 10. OUTPUT AMPLIFIER

The output amplifier is a gain section designed to interface with external sound modulators or additional amplifier stages. The output is an operational amplifier operating as a summer and inverter, as illustrated. The output is an emitter-follower without a load resistor. Therefore, pin 13 should have a pull-down resistor, RE, with a value ranging from 2.7K to 10K ohms. The equivalent of the input circuitry for the amplifier section is shown in the next column.

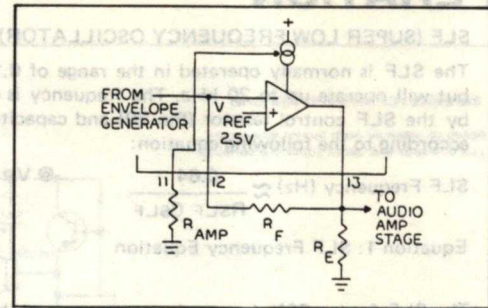

Operational Amplifier

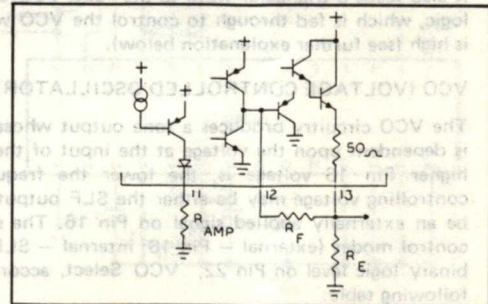

Operational Amplifier Internal Input Circuitry

The resistor value RAMP sets the operating currents for the operational amplifier's internal circuitry and is the main adjustment to control the amplifier's output amplitude. The value of this resistor is normally between 47K and 220K ohms. Any lower resistance will typically begin to saturate the operational amplifier and is especially noticeable on the decay portion of the sound envelope.

The feedback resistor, RE, is used to compensate for external variations and also any chip-to-chip variations. This is accomplished by connecting the feedback resistor between the last amplifier stage and the input Pin 12, as shown below. The feedback resistor is connected to the last stage at a point where the signal is in-phase with the operational amplifier's output. The peak output voltage is determined by the following equation:

$$V_{OUT} \approx \frac{3.4R_F}{R_{AMP}} \quad \text{@ VREG} = 5.0V$$

Where VOUT = volts  
R = ohms

The dynamic output range is limited to 2.5 volts peak-to-peak before clipping occurs. The example shown is ideally suited for most applications. The amplifier is in a push-pull configuration and will draw current only when a signal is present. Depending on the voltage applied to the collector of Q1, this circuit will provide approximately 300-400mW of power into an 8-ohm speaker.

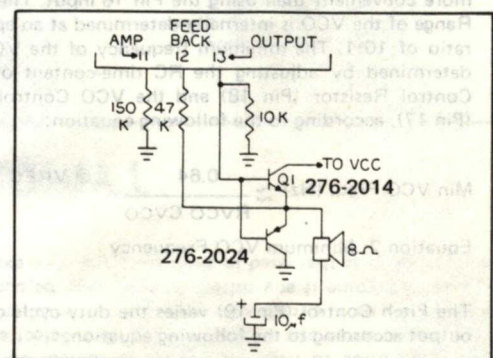

If the amplitude of the sound output is to be varied for particular sounds, the resistance RAMP can be varied by logic control lines. This can be done (as described earlier) by using the logic control line to switch a logic gate that will put a resistor in parallel with RAMP.

Special filtering can be added to the output of the amplifier or can be included in the feedback section of the operational amplifier. Since the output of the amplifier always contains square waves, filtering will change the timbre (harmonic content) of the output signal.

Other external sounds may be added to the input of the amplifier at Pin 12. This input can be made either directly or through a series resistor. An example of an input configuration to add a person's voice to the system is shown below. This could be used to sing along or talk along with the sounds being generated by the chip.

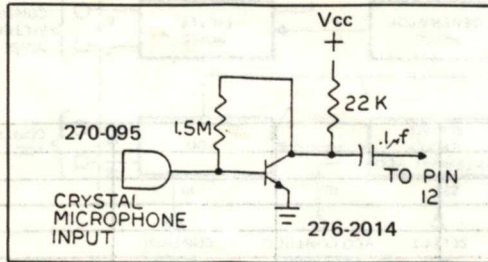

## 11. REGULATOR

Either a 5-volt regulated supply may be applied to Pin 15 (VREG) or a 7.5-volt min/9.0 volt max regulated supply may be applied to Pin 14 (VCC). Pin 15 (VREG) can be used as a 5-volt regulated supply for the rest of the system with a current supply of up to 10MA out of the IC.

## 12. NOTE:

Control resistors and capacitors may be eliminated if the desired sound does not require that generator or logic section. For dedicated sound, the logic inputs (Pins 1, 9, 22, 25, 26, 27, 28) may be hard-wired for high or low logic levels. Individual sounds (single or multiple) will determine which of the other components are required.

## DESIGN SEQUENCE FOR DEVELOPING COMPLEX SOUND

An approach to designing custom complex sounds will be illustrated and discussed in this section. These steps may vary depending on your particular applications for the IC.

The first step is to build a "sound demonstrator box" similar to the one shown below. This is a time-saving step and will aid in analyzing and understanding each section of the chip, help in determining what sounds are desired, and in determining the component values to obtain those sounds. The demonstrator box typically requires a couple of days for a technician to build. If portable operation is desired, a 9-volt battery may be used for a power source.

The next step is to check out each section of the IC using the demonstrator box.

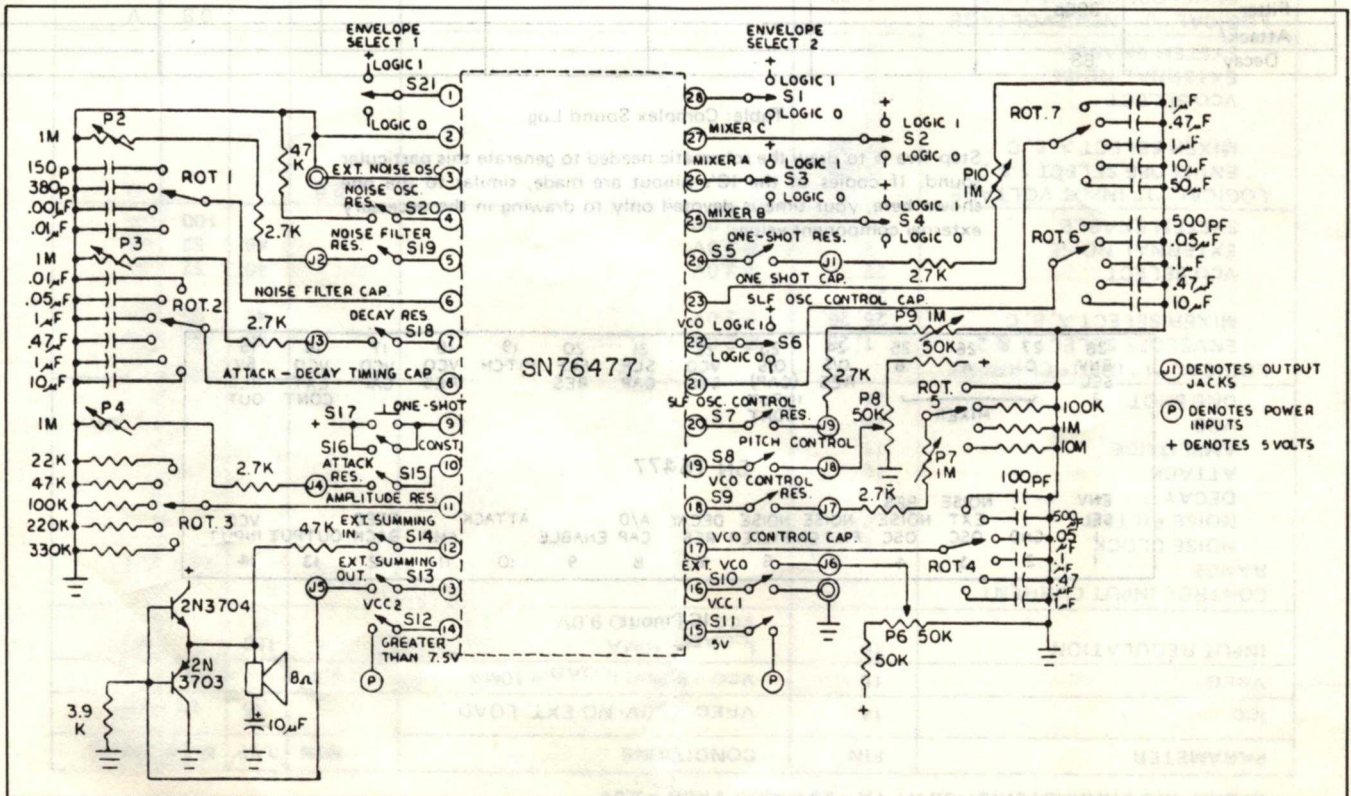

The third step is to choose a simple sound, such as a tone or noise only, and approach the reproduction of that sound scientifically. For example, suppose a gun-shot sound is chosen. It requires noise, one-shot timing and attack/decay. Therefore, program the envelope select for one-shot timing and attack/decay. Therefore, program the envelope select for one-shot operation, and noise should be selected for the mixer's output. The attack time should be rapid, which suggests that the attack resistance must be at a minimum value. The gun-shot requires some decay, so the resistance used will have to be adjusted while firing the one-shot and listening to determine the correct length. The one-shot's RC timing should be short. However, if it is too short, the sound output will never have time to provide the necessary amplitude to the output amplifier. Therefore, the one-shot's RC values must be adjusted longer than expected and then be decreased to the desired length. Finally, the noise filter's RC network should be adjusted for the desired gun-shot noise.

Step four requires logging the component values and logic levels used in your sound for future reference. The table below shows a sound logging table including values for the gun shot example. This step is very important since it will keep a log of interesting sounds and prevent the wasted time of trying to repeat an identical sound you have produced in the past. All component values can be determined from the "demonstrator box". Use an ohmmeter to measure required resistor values by connecting it to a particular sound section's resistor jack and opening the switch that is in series with the IC. The capacitor values are determined from the labels on your demonstrator box.

	GUNSHOT				
<b>RESISTORS</b>					
Decay	680K				
Attack	4.7K				
Amplitude	150K				
One-Shot	330K				
VCO	—				
Filter	82K				
SLF	—				
Pitch	—				
VCO Ext	—				
<b>LOGIC CONTROL</b>					
Env 1	1				
Env 2	0				
Mixer A	0				
Mixer B	1				
Mixer C	0				
VCO Select	—				
<b>CAPACITORS</b>					
One-Shot	.01				
SLF	—				
VCO	—				
Filter	390p				
Attack/					
Decay	.68				

Table: Complex Sound Log

Step five is to draw the schematic needed to generate this particular sound. If copies of the IC's pinout are made, similar to the one shown here, your time is devoted only to drawing in the necessary external component values.

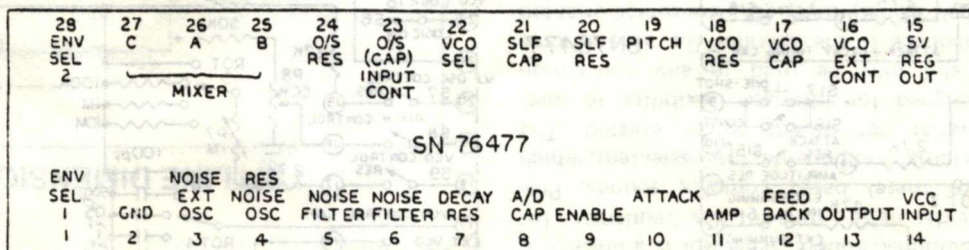

IC Pinout

Step six requires a breadboard of the circuit. Then make any necessary adjustments to the component values.

Step seven is used when several sounds that you have developed (through steps three to five) need to be combined. Compare each individual sound schematic produced in step five. Select all common components on each circuit and draw this on another IC pinout copy. Then determine if any differing values may be compromised to the same value as that used in another sound. For example, if a

gun-shot was determined to have a certain set of RC one-shot values, and a ricochet had another set, then could there be a compromise between the two which would make one set common to both? Decide on the type of switching logic you will need to switch between sounds, plus any component additions and add to this drawing.

In step eight, this preliminary system should be bread-boarded. Then each sound should be adjusted until that sound is satisfactory.

## TYPICAL APPLICATIONS

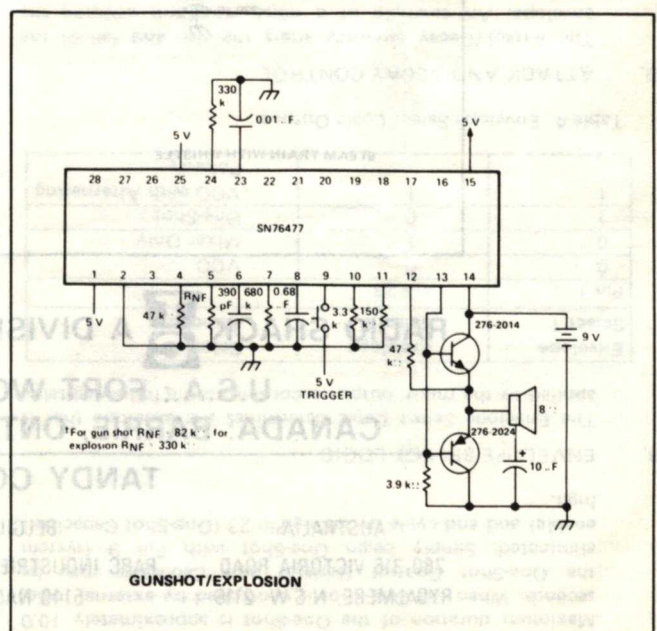
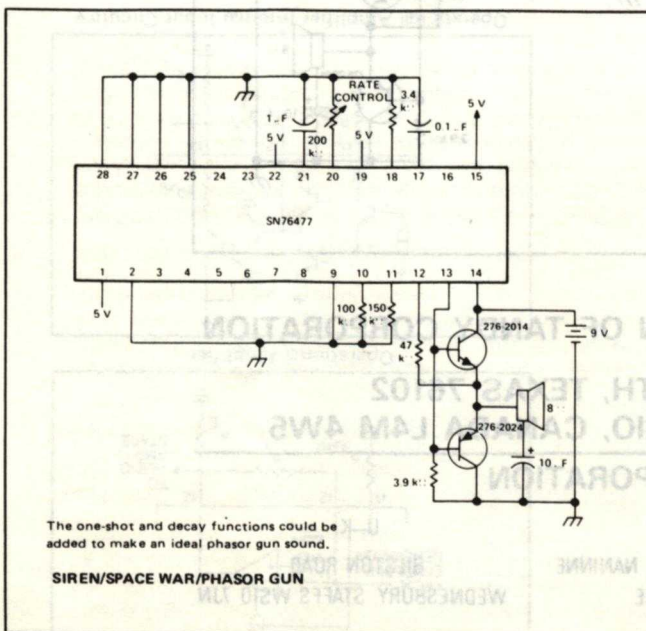
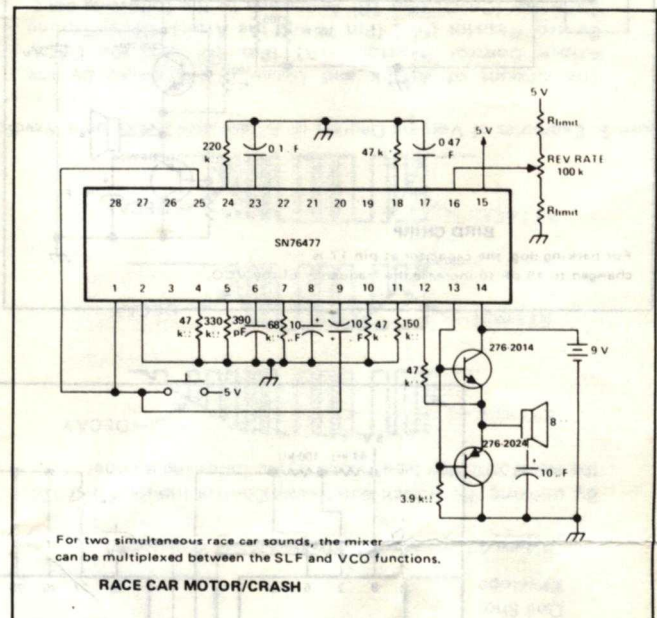
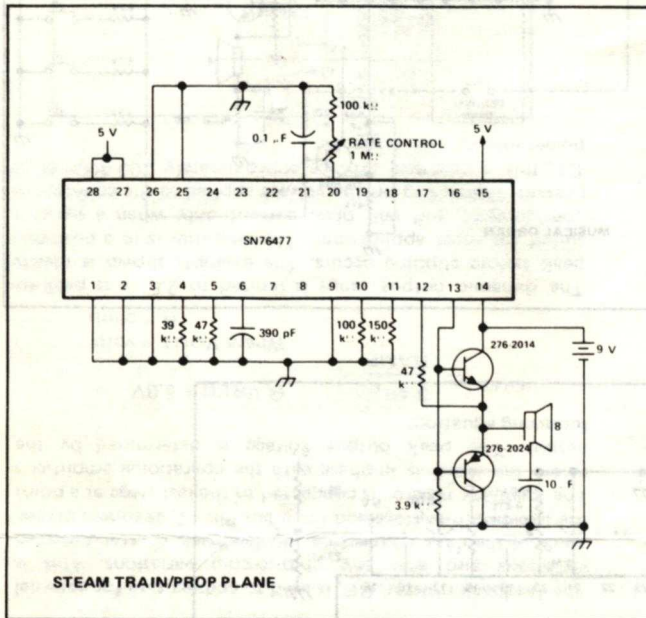

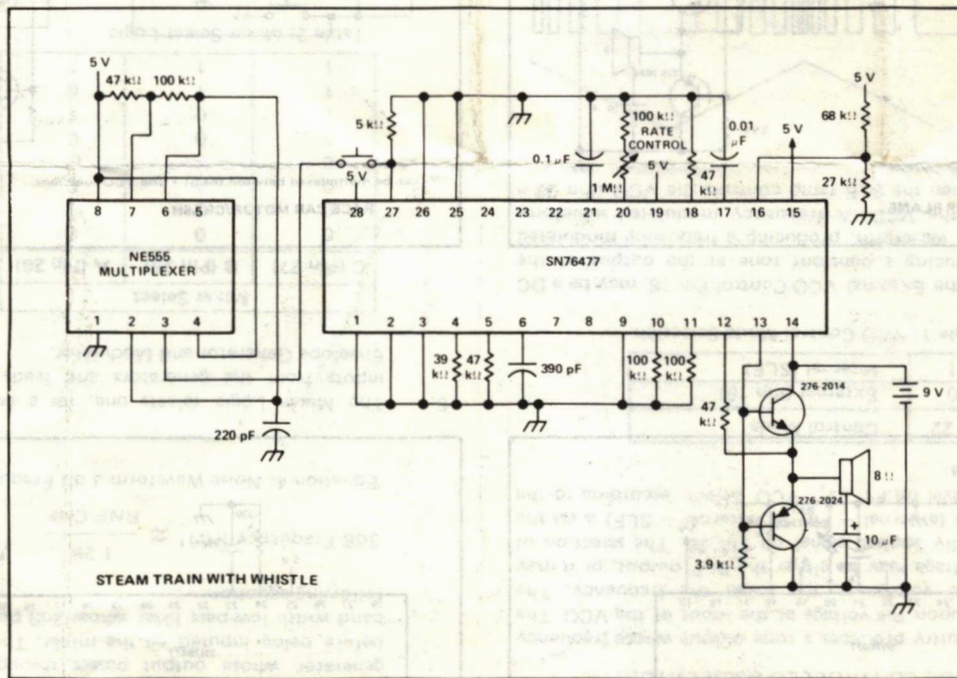
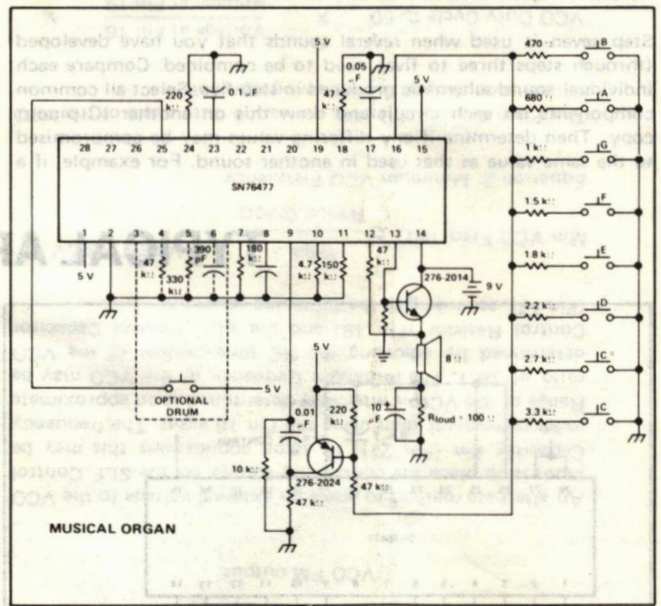
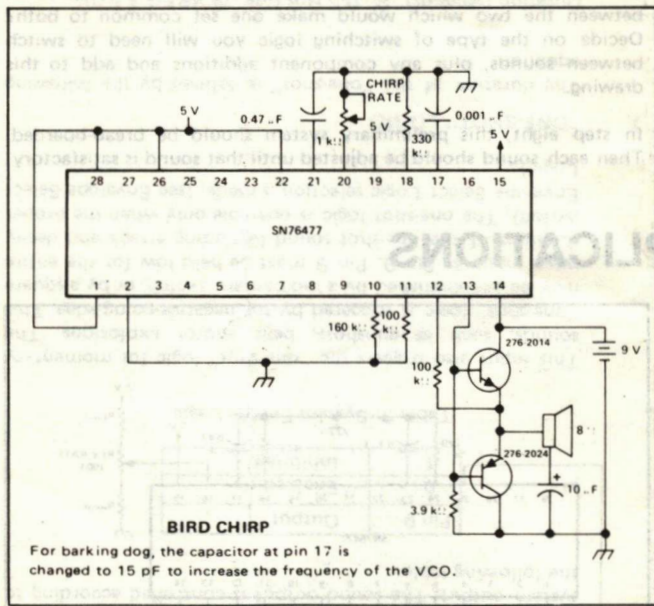

**RADIO SHACK**  **A DIVISION OF TANDY CORPORATION**  
**U.S.A.: FORT WORTH, TEXAS 76102**  
**CANADA: BARRIE, ONTARIO, CANADA L4M 4W5**

**TANDY CORPORATION**

**AUSTRALIA**  
 280-316 VICTORIA ROAD  
 RYDALMERE, N.S.W. 2116

**BELGIUM**  
 PARC INDUSTRIEL DE NANINNE  
 5140 NANINNE

**U. K.**  
 BILSTON ROAD  
 WEDNESBURY, STAFFS WS10 7JN

If You Didn't Get This From My Site,  
 Then It Was Stolen From...

[www.SteamPoweredRadio.Com](http://www.SteamPoweredRadio.Com)

Printed in U.S.A.