

BMX III

PACIFIC RECORDERS & ENGINEERING CORPORATION



If You Didn't Get This From My Site,
Then It Was Stolen From...
www.SteamPoweredRadio.Com

IT'S EVERYTHING A BMX SHOULD BE.



With program origination, your choice of an on-air console is the most critical equipment decision you can make. You don't have to be an engineer to know that your "board" is the heart of the station's operations. If your console isn't in top condition, odds are your station's health isn't either. Unfortunately, gaining more flexibility and better performance from your console isn't a matter of giving it more exercise. It's usually a matter of retirement.

When you think about all that needless anxiety, the frustrating experiences you've had over the years attempting to make yesterday's "old dog" console sit-up and perform today's new programming tricks, there's no doubt you're going to feel genuinely excited after you read about our new BMX Series Three.

With our BMX III, you're going to examine a new on-air console design that brings a whole new outlook to your station's operations. With the Series III, we've retained the essential concepts developed for our legendary BMX Series I & II consoles and enhanced them with the latest features and facilities we've incorporated into our new ABX and AMX operations consoles.

You'll see that the latest technology, important innovations and new, useful features we designed into the BMX III have one essential purpose: to make your station run better. You'll also see that our dedication to quality hasn't changed either. Pacific Recorders & Engineering is a company that is zealously dedicated to the well-being of your business. You see, that's how we stay healthy.

Should you wish to see for yourself how dedicated we are, just check our references. With so many stations and networks across the country investing in a BMX console, there's undoubtedly someone in your own backyard who's already had the advantages of owning a BMX. You may already have discussed the merits of a BMX with someone who's been eager to share his experience and enthusiasm. Quite possibly, even a competitor.

If You Didn't Get This From My Site,
Then It Was Stolen From...

www.SteamPoweredRadio.Com



Pacific Recorders & Engineering Corporation
The choice for more #1 stations.



While cosmetics are easily copied, the features, functions, and flexibility of BMX Series consoles are what have made BMX systems the outright leader in major market installations.



TODAY'S COMPLICATED RADIO PROGRAMMING AND PRODUCTION NEEDS MORE FLEXIBILITY: THE BMX III ACHIEVES THIS GOAL WITHOUT SACRIFICING SIMPLICITY OF OPERATION.

The BMX III on-air console was designed with the capacity to handle a talk show with two separate telephone mixes, record a stereo feed for later broadcast, plus the capability to work and communicate with two studios and a remote, all at the same time. In addition, the new BMX III may be optionally equipped with two effect/foldback sends and a stereo effects return, all with extensive remote control logic. This outstanding capacity has not been gained, however, at the expense of simplicity. The BMX III retains the clean, uncluttered design so important for operator understanding and simple operation. ■

TODAY'S ON-AIR STUDIOS NEED A CONSOLE THAT'S PACKED WITH PRACTICAL FEATURES.

THE BMX THREE — FEATURES AT A GLANCE

- Three main stereo mix buses.
- Distribution line amplifiers on each main output.
- Full and independent remote control logic on each input of microphone and line modules.
- Stereo cue system with automatic console headphone monitor switching.
- The monitor system provides independent and unique outputs for the console, host, co-host, and guest headphone feeds.
- Stereo solo-in-place monitoring system.
- Multi-function metering with automatic cue and solo level display.
- Monitor facilities for two studios.
- Multi-way intercommunication system, including producer and external feeds.
- Multi-frequency, low distortion test oscillator.
- Voice slate system with identification tone.
- Two telephone mix-minus feeds plus telephone monitor mix.
- Two optional effect/foldback send mix buses, each with remote control logic.
- Optional stereo effects/reverb return with remote control logic.
- Fully regulated, independent supplies for audio, logic and phantom power.
- On-board audio supply regulation on each module.
- Mainframe fully wired for all present and future inputs, outputs, patch points and logic.
- Connector panel silk screened with clear, functional designations.
- Audio and logic interconnection system is compatible with AMX and ABX series consoles.
- Mainframes for 10, 14, 18, 22, 26, 30, 34 input positions, larger frame sizes available.
- Console supplied with installation connectors and tools, service tool kit and spare parts kit.

Keep your crew cooking with a PR&E system that keeps delivering top performance no matter how complex or demanding your programming requirement.

TODAY'S RADIO STATIONS STILL NEED ROCK-SOLID RELIABILITY AND THE HIGHEST QUALITY THAT INSURES PERFORMANCE WELL INTO TOMORROW.

With a BMX, the reliability starts with a sturdy housing. A BMX has always been fabricated with superior materials and methods. Heavy gauge aluminum alloy end panels are made on CNC mills for the ultimate in dimensional accuracy. A precision sheet metal chassis is then fastened to these end panels to form the mainframe housing. This BMX housing will not twist or flex and, therefore, will not degrade circuit card contacts or place strain on circuit traces. We minimize complicated and error-prone hand wiring through the use of plug-in circuit boards and "mother boards". The main bus board is strengthened and shielded by a continuous ground plane which yields the ultimate in RFI and noise isolation. We complement the solid mainframe design with attractive, solid oak trim that will withstand many years of rigorous professional use.

With a BMX, this reliability is extended to all sub-assemblies and components. For example, only glass epoxy double-sided circuit boards are used. Double-sided boards allow the layout of components for optimum performance and support the use of ground plane shielding which further reduces the console's susceptibility to RFI, noise and crosstalk. For added service convenience, the components on each circuit board are identified with silk screen designations. All card connecting fingers and their mating connectors are gold-plated for the highest reliability.

Throughout the BMX design, we use only first-quality components. Advanced discrete and integrated circuitry yields very low noise and distortion and provides excellent frequency response and headroom/overload performance. At least 30 dB of microphone and line input headroom is maintained to provide that extra margin for hot levels and "operator error". Mixers are

full-travel Penny & Giles Series 4000 conductive plastic faders. Pushbuttons are Honeywell, EAO and Schadow, chosen for their extended life ratings and superior "feel". Audio transformers, where employed, are by Jensen. The VU meters conform fully to American National Standard C 16.5-1954 and are driven by bridging buffer amplifiers. Optional peak program meters (PPM) conform to British Standard 4297:1969. ■

WE'VE USED ONLY THE BEST LOGIC AND SWITCHING TECHNOLOGY IN THE BMX III, BECAUSE RELIABILITY AND PERFORMANCE GO HAND-IN-HAND.

The sophisticated control logic of the BMX III utilizes CMOS integrated circuits. CMOS devices operate efficiently on low current and power, and offer silent and flexible logic control because they are highly immune to electrical noises and strong RFI fields. Thus, as the logic operates in a BMX III, you won't hear "chirps" or "clicks". This 12 volt CMOS control logic is also easy to interface to external "outside" equipment like lamps and relays.

We complement the superior performance characteristics of CMOS logic circuitry with miniature, dry nitrogen-sealed, gold-contact relays for all primary path audio signal switching. These special relays (much more costly than conventional TTL or FET design components), are extremely reliable, and cannot degrade audio performance with unwanted noise or distortion. By

comparison, other console designs typically use inexpensive TTL or FET analog switches which invariably introduce some form of non-linear distortion and degrade an entire audio console's performance; they're any easy, inexpensive shortcut for the average console design.

In a BMX III, less critical audio side chains (like Cue, Solo and Talkback) employ the highest quality, socketed CMOS analog switches. These solid-state, low power devices are capable of handling full level signals and operate in medium impedance circuitry to minimize non-linear distortion. This side chain design complements the critical main audio signal path relay design by offering the benefit of minimal current drain to the overall console system.

The BMX III has extensive and independent remote control logic for each input of the microphone and line input modules. Logic interface/translator units are available with the BMX III. The outputs of the control logic are buffered by short-proof discrete transistor circuitry. ■

RELIABILITY AND PERFORMANCE ALSO MEANS SUPERIOR ERGONOMICS AND A CONSOLE THAT FITS INTO THE REAL WORLD.

The BMX III is a low-profile design, a real world benefit that should be immediately evident to any broadcaster. All module front panels are constructed from anodized aluminum extrusions and carry aluminum inlays coated with durable polyurethane paint and silk screened with clearly labeled nomenclature.

Every BMX mainframe leaves plenty of room for the broadcaster to arrange his peripheral equipment. All active electronics are immediately accessible from the top of the console: panel modules simply unplug from the mainframe housing. Perhaps the most important aspect to a BMX's engineering is the careful attention that's been

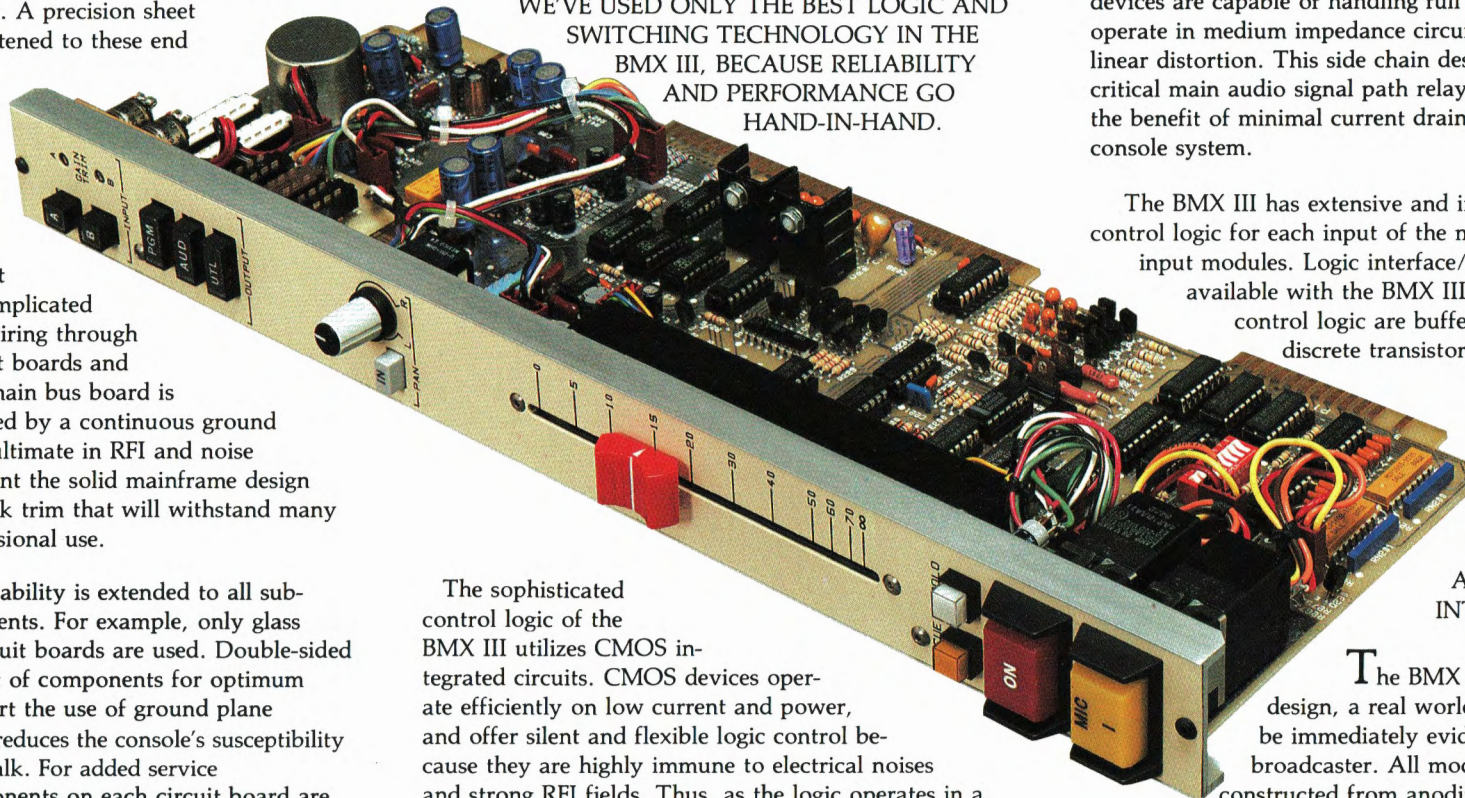

paid to the logical placement of switches and controls. There isn't an easier board to get to know. More importantly, there isn't a board that's easier to run. Just look around at a host of look-alike consoles that curiously resemble a BMX on the surface.

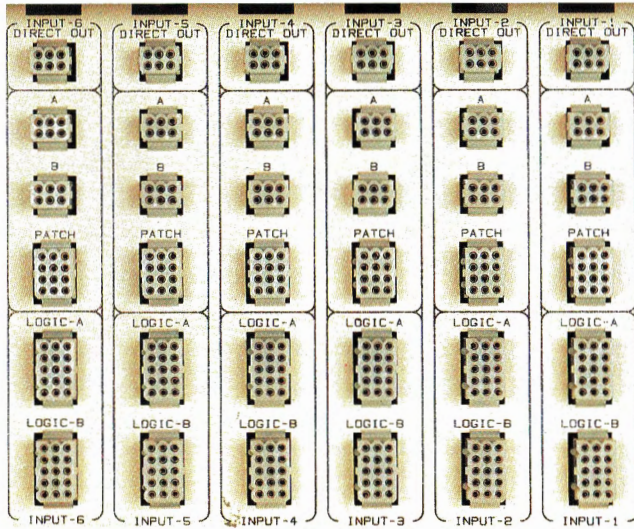

Time-consuming, hand wired terminal blocks are eliminated with a BMX III. All interconnections use proven, reliable, mating connectors for rapid, easy installation.

A BMX's separate rack mounting power supply is constructed in a rugged steel chassis and features massive regulator heat sinks. For convenience, it comes with a six foot interconnecting cable. The audio, logic and microphone phantom power supply voltages are individually regulated and switched with magnetic circuit breakers for maximum reliability.



Regardless of mainframe size, the low profile design of BMX-III gives you plenty of viewing room to your studio — even when you add our optional copy stand or equipment overbridge.

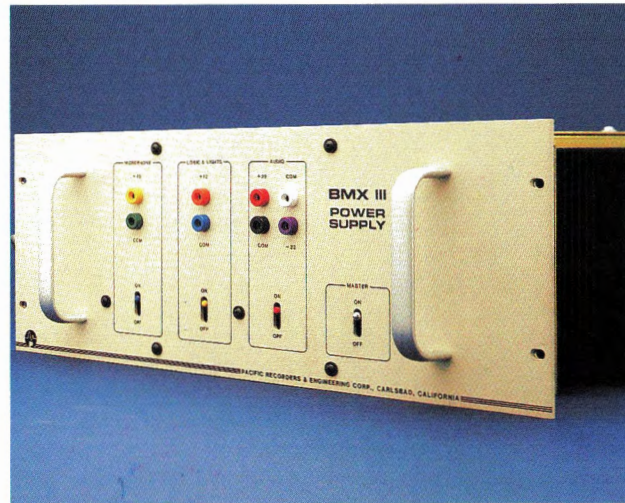

Every BMX III comes with a rugged power supply designed to comfortably handle the heaviest BMX use — reliably and coolly.

All audio input/output and logic wiring between the console and external equipment is accomplished with easy-to-use mating connectors. Time-consuming hand wiring to terminal blocks is eliminated. Console mating connectors, pins and tools are supplied with the BMX III. By prewiring the studio connectors, a BMX III console can be installed and on the air in a few hours.

ONE LAST WORD BEFORE YOU LOOK INTO MORE DETAILS.

Our BMX consoles have become the standard by which many broadcasters evaluate other competitive offerings. Frankly, we're flattered by this, but not surprised. Because we've stayed in close touch with your needs, the BMX has become an evolutionary design; the purpose of which is to continuously reach for and set the highest radio broadcast standards — in features, performance, reliability and that all-too-elusive factor, quality.

If you believe that all these attributes have been attained in the exemplary console design of the BMX III, then we welcome you to a select user's group of professionals — broadcasters who have decided a Pacific Recorders & Engineering console is the best value that money can buy.

BMX III FUNCTIONAL BLOCK DIAGRAM

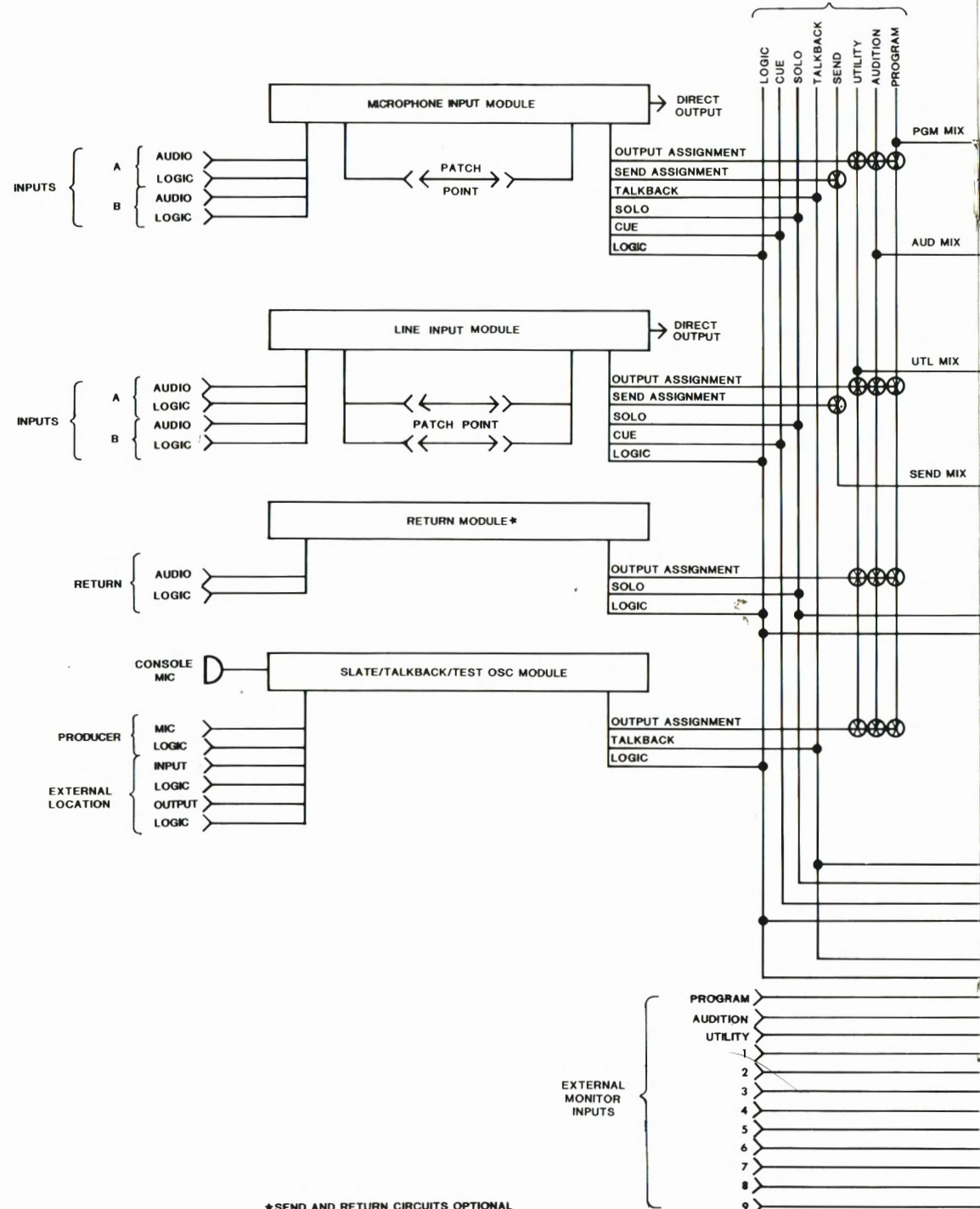

*SEND AND RETURN CIRCUITS OPTIONAL

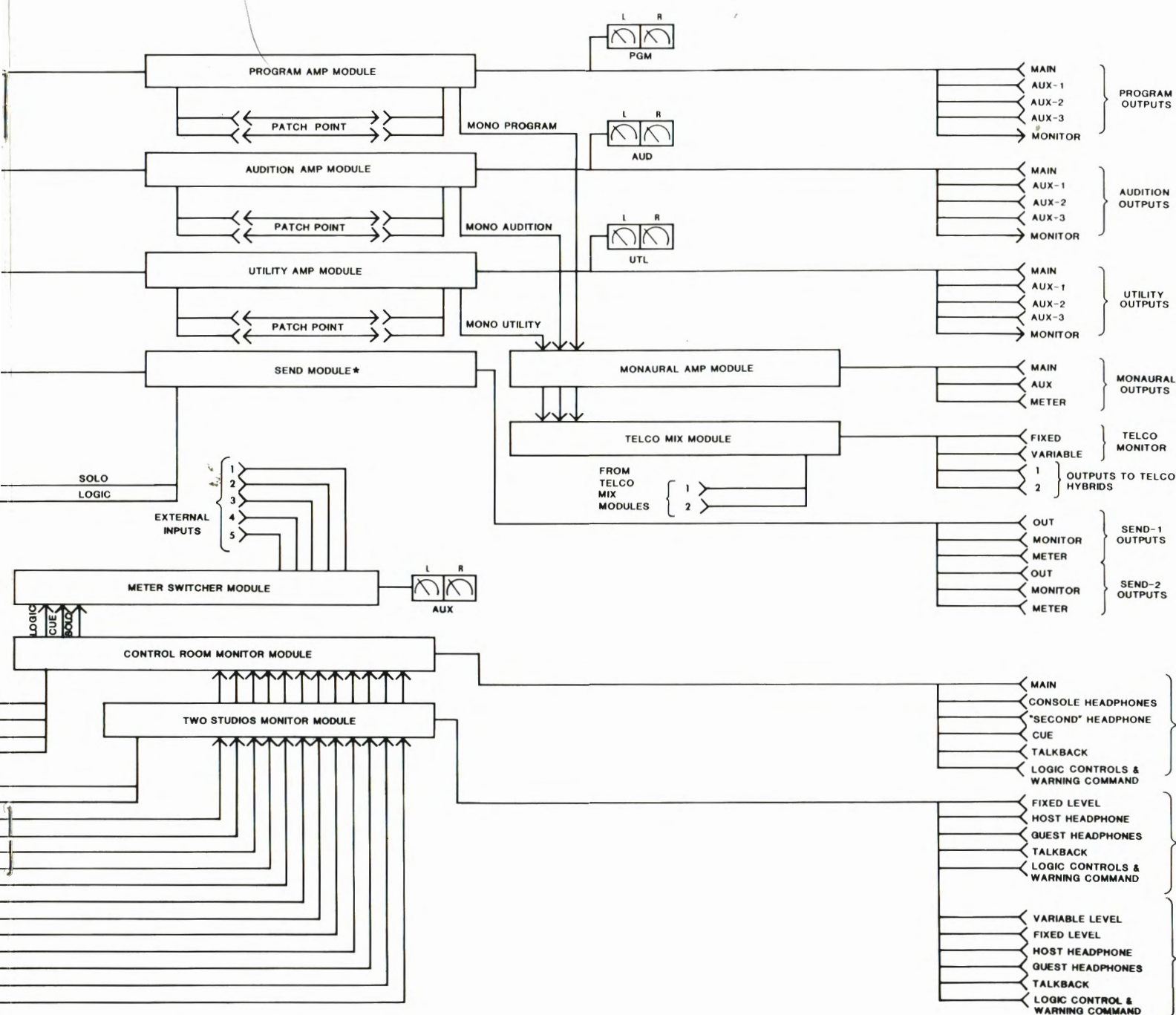

PROGRAM OUTPUTS
 MAIN
 AUX-1
 AUX-2
 AUX-3
 MONITOR

AUDITION OUTPUTS
 MAIN
 AUX-1
 AUX-2
 AUX-3
 MONITOR

UTILITY OUTPUTS
 MAIN
 AUX-1
 AUX-2
 AUX-3
 MONITOR

MONAURAL OUTPUTS
 MAIN
 AUX
 METER

TELCO MONITOR
 FIXED
 VARIABLE
 OUTPUTS TO TELCO HYBRIDS
 1
 2

SEND-1 OUTPUTS
 OUT
 MONITOR
 METER
 OUT
 MONITOR
 SEND-2 OUTPUTS
 METER

CONTROL MONITOR OUTPUTS
 MAIN
 CONSOLE HEADPHONES
 "SECOND" HEADPHONE
 CUE
 TALKBACK
 LOGIC CONTROLS & WARNING COMMAND

STUDIO-1 MONITOR OUTPUTS
 FIXED LEVEL
 HOST HEADPHONE
 GUEST HEADPHONES
 TALKBACK
 LOGIC CONTROLS & WARNING COMMAND

STUDIO-2 MONITOR OUTPUTS
 VARIABLE LEVEL
 FIXED LEVEL
 HOST HEADPHONE
 GUEST HEADPHONES
 TALKBACK
 LOGIC CONTROL & WARNING COMMAND

Panel 1: INPUT (A, B, GAIN TRIM), OUTPUT (PGM, AUD, UTL), PAN (IN, L, R), VOLUME (0-80), CUE/SOLO, ON, MIC 1

Panel 2: INPUT (A, B, GAIN TRIM), OUTPUT (PGM, AUD, UTL), PRE (1, 2, SENDS), PAN (IN, L, R), VOLUME (0-80), CUE/SOLO, ON, OFF

Panel 3: INPUT (LEFT, RIGHT, GAIN TRIM), OUTPUT (PGM, AUD, UTL), PAN (IN, L, R), INPUT MODE (SUM, RIGHT, LEFT, STEREO), VOLUME (0-80), CUE/SOLO, ON, TT 2

Panel 4: INPUT (LEFT, RIGHT, GAIN TRIM), OUTPUT (PGM, AUD, UTL), PRE (1, 2, SENDS), PAN (IN, L, R), INPUT MODE (SUM, RIGHT, LEFT, STEREO), VOLUME (0-80), CUE/SOLO, ON, OFF

Panel 5: EXTERNAL OUTPUT, EXTERNAL INPUT, PRODUCER MIC, CONSOLE MIC, SLATE LEVEL, FREQUENCY (30-200), MULTIPLIER (100, 10, 1), LEVEL, OSC OSCILLATOR, SLATE, STUDIO 1, STUDIO 2, EXT

Panel 6: METER SWITCHER (SOLO, CUE)

Panel 7: LEFT, GAIN TRIM, RIGHT

Panel 8: VOLUME (0-80)

■ MICROPHONE INPUT MODULE

The Microphone Input module accommodates a wide range of input levels to permit use of all contemporary microphones. Input preamplifier gain is adjustable for nominal inputs of -60 dBu to -35 dBu. The A/B input selector provides two microphone inputs per module, each with programmable monitor mute selection for control room or either of two studios. The mute circuitry incorporates an automatic 40 millisecond delay before the microphone is turned on to permit "room reverb" to decay off-mic. Each microphone input is provided with separate remote control capability for ON/OFF, COUGH and multiple TALKBACK functions. The PAN control may be inserted with the IN button to provide positioning of the microphone signal in the stereo image. The module output may be assigned to any combination of PROGRAM, AUDITION and UTILITY by the self-indicating OUTPUT buttons. The illuminated CUE button provides stereo pre-fader cue monitoring. The illuminated SOLO button provides monitoring of solo-in-place which is post-fader and pan. The channel ON/OFF buttons are illuminated to indicate the status of the channel. In addition, the ON button may be programmed so that momentary depression provides cough muting. Phantom power circuitry for condenser microphones is user assignable for both the A and B inputs.

The microphone module may be equipped with an optional SEND control which can be assigned to either or both of two send buses and is provided with a PRE/post-fader button switch. Stereo send is possible as a user option; assigning the send to either send bus results in a mono-mix signal to that bus, however, the send will be stereo when both bus assignment buttons are engaged.

■ LINE INPUT MODULE

The Stereo Line Input module will accommodate nominal input levels from -12 dBu to +8 dBu. The A/B input switch selects either of two stereo inputs. Separate logic control is available on each input for the remote control of tape machines and/or other sources by the module. The PAN control may be used to balance a stereo signal source or to position a mono signal in the stereo image. An INPUT MODE switch allows input selection of stereo, left channel only, right channel only or the sum of left and right channels. The module output

may be assigned to any combination of PROGRAM, AUDITION and UTILITY by the self-indicating OUTPUT buttons. The illuminated CUE button provides stereo pre-fader cue monitoring. The illuminated SOLO button provides monitoring of solo-in-place which is post-fader and pan. The channel ON/OFF buttons are illuminated to indicate the status of the channel.

The line module may be equipped with an optional SEND control which is provided with a PRE/post-fader switch and can assign a mono-mix of the signal to either or both of two send buses. The user option for stereo send is available as described for the Microphone Input module.

Each Line Input module is equipped with a comprehensive family of control logic capability which includes the remote control of module ON, OFF, CUE and SOLO functions with status tally lights. Also provided are ready status and start/stop command pulses for turntables, cartridges and reel-to-reel tape machines. The ready status illuminates the channel OFF button whenever a tape is threaded or cartridge is loaded and ready for play. The ON button starts the remote controlled equipment as well as turning the channel on. The module audio is automatically turned off upon the receipt of a cartridge fast wind or end of tape command. In addition, the module may be set to control the console mounted timer system for the automatic up-time of events.

■ SLATE/TALKBACK/TEST/OSCILLATOR MODULE

The Slate/Talkback/Test/Oscillator module provides a test oscillator, a slate tone oscillator and talkback facilities for the BMX III console. The test oscillator generates low-distortion, stable amplitude tones to allow system test and line-up with any of 15 frequencies. The tones may be assigned to any combination of the PROGRAM, AUDITION and UTILITY mix buses.

SLATE commentary may be added to a tape recording by the console mounted electret microphone and/or from an external producer's microphone. A low distortion spotter tone (nominally 30 Hz, adjustable) with carefully controlled envelope rise and fall times, may be recorded with the commentary for ease of fast-wind identification of the cuts on a track.

The console and producer microphones can talk to any of two studios plus a remote or external location, such as a screener booth, 2-way, etc. The external location can also talk back to the studios as well as the control room. The frequency response of all the talk microphone preamplifiers has been carefully shaped to favor speech communication.

■ METER SWITCHER MODULE

The auxilliary meters in the BMX III meter panel are driven by the Meter Switcher module. This module provides switchable metering facilities for the AUDITION and UTILITY outputs in the smaller mainframe sizes. The unassigned inputs may be used to meter user determined external sources. The module automatically defaults from the selected status whenever a CUE or SOLO button is engaged on any module. The auxilliary meters will then display the nominal operating level at the CUE or SOLO point selected. This enables a quick input level check when displaying CUE, and very convenient level line-up when displaying SOLO. The SOLO metering function eliminates the need to use a console output bus for preview and level setting.

■ STEREO OUTPUT MODULE

The Stereo Output module contains the mixing and distribution amplifiers for a console line output. The console is supplied with three of these modules, one each for the PROGRAM, AUDITION and UTILITY buses. Each module supplies four stereo distribution outputs; each output is capable of supplying up to +28 dBm. Patch send and return points are available for the connection of external processing equipment and/or a patch field. The output is an active balanced design; output transformers are available as an option.

■ REMOTE LINE SELECTOR MODULE

The Remote Line Selector module provides a selection of 10 stereo signals switched to one output. Up to two parallel-input selector modules may be installed in the BMX III. The inputs and outputs for the modules are all brought out to the connector panel for ease of assignment. Typical applications include use as a line pre-selector ahead of input modules and tape recorders.

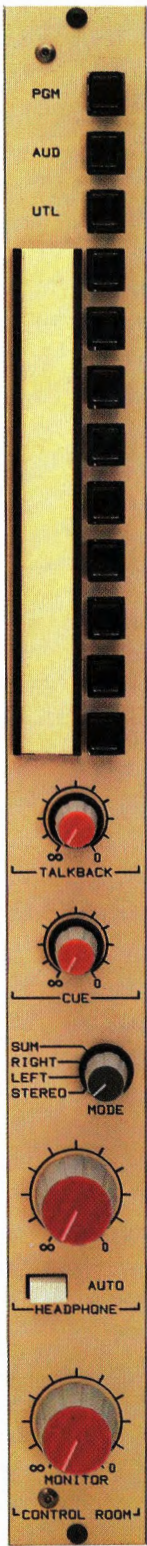

CONTROL ROOM MONITOR MODULE

Monitoring of PROGRAM, AUDITION and UTILITY or any of nine external signals is provided by the interlocking monitor selector. The MONITOR and HEADPHONE potentiometers are sealed long-life conductive-plastic controls which were custom designed by Penny & Giles for the BMX III, AMX and ABX consoles. The AUTO headphone monitoring facility has been derived from the ABX console and is unique in the industry. Whenever an input module CUE button is engaged, the console operator's headphones automatically switch from the normal stereo monitor mode to one of two user assignable states; these are stereo cue, or mono cue in one earphone and mono monitor in the other. The headphone feeds to a co-host and/or guests are not affected.

adjustable degree of monitor level reduction during talkback. The TALKBACK control adjusts the volume of incoming talk signals. Talkback may be monitored with an independent amplifier and loudspeaker, or through the stereo cue system. The CUE control adjusts the level of the cue system. Logic circuitry is provided for the remote control of monitor dim and mute.

STUDIO MONITOR MODULE

The Studio Monitor module is expressly designed for applications where separate voice/announce booths or conference studios are required. This module provides the monitor, headphone and talkback facilities for up to two studios. Monitoring or PROGRAM, AUDITION and UTILITY or any of nine external signals is provided by an interlocking monitor selector. MONITOR, DIM and TALKBACK level controls are provided along with a TALK OVER MUTE button for each studio. The mute override button enables talkback to a studio even when the monitor speakers are muted. This would normally be used when doing off-air production work and/or when the talent chooses not to wear headphones.

The module has several outputs to meet most any combination of monitoring requirements. The main output is adjustable along with the degree of dimming during talkback. Fixed level outputs are available for those situations where the studio personnel are provided

their own monitor and headphone level controls. The output for talent headphones is provided with talkback and a preset dim, a second output is provided for guest headphones which contains neither talkback or dim. Logic circuitry is provided for the remote control DIM and MUTE for each of the studio monitor sections.

MONAURAL OUTPUT MODULE

The Monaural Output module provides a selection of the three main outputs. The module may select the PROGRAM, AUDITION and UTILITY signals to derive a monaural output. The output is an active balanced design; an output transformer is available as an option.

MONAURAL OUTPUT/TELCO MIX MODULE

This combination module provides the features of the Monaural Output module plus the facilities for deriving mix-minus feeds for telephone hybrids. The telco mix section derives three unique mixes of the signals from two telephone callers and a selection of the PROGRAM, AUDITION and UTILITY buses.

The telephone signals which are to be broadcast, are selected and controlled by the input modules connected to the external hybrid systems. The Telco Mix module receives the audio from the input modules and sums them. This sum signal is routed to the meter selector and to the mix-monitor output. This telephone mix-monitor output is very useful when talk show talent and/or guests prefer not to use headphones.

The module provides for the selection of the output bus which is to contain the "base-mix" to be fed back to all the callers so that they may hear what is transpiring, even before air time. The signal fed back to a given caller includes the selected bus plus all the other callers, except himself (mix-minus). The signals fed back to the callers, may be passed through the on-board telephone bandpass filters for improved hybrid operation.

SEND & RETURN/MONAURAL/TELCO MIX MODULE

This module combines the Monaural Output/Telco Mix module with the facilities of the Send & Return module. This module is installed to support the use of the send circuits in the input modules and to provide return mix and assign circuitry for effects such as reverb. The Send & Return sections of this module operate identically to the dedicated Send & Return module described below.

SEND/RETURN MODULE

The optional Send/Return module contains both the send amplifiers and the stereo return circuits. The send portion of the module contains the mixing and output amplifiers for the two effects/foldback channels. Each of these has a variable LEVEL control with ON/OFF and SOLO facilities. The stereo effects return section of the module is equipped with a conductive plastic fader, MODE selector, PAN control, ON/OFF/SOLO buttons and output assignment buttons. Logic circuitry is provided for the remote ON/OFF control of both of the send circuits and the return channel.

REMOTE CONTROL PANELS

Tape deck remote control panels are available for most professional reel-to-tape recorders. The engraved RWD, FWD, STOP, PLAY and RECO buttons are function color-coded to common industry practice and are supplied with tally lamps.

Cartridge deck remote control panels are available for TOMCAT, MICROMAX and ITC cartridge recorders. Panels for other machines are available by request. Engraved buttons for TERTIARY tone, SECONDRY tone, STOP, START and RECO are provided. The buttons are supplied with the appropriate voltage tally lamps.

The timer control panel provides illuminated START, STOP, RESET and HOLD buttons for the meter panel mounted DT-4 digital timer. An AUTO button couples the timer's reset and restart functions to the console timer reset command bus for the automatic up-time of events, (start with module on).

BUILD A BMX III JUST THE WAY YOU WANT IT.

The BMX III is available in several mainframe sizes to accommodate every broadcast requirement. Each BMX III is factory wired and fully tested for an entire complement of modules. You may order the console with fewer than capacity and then add modules as needs arise. Simply plug in the extra modules. A universal layout enables any input position to accept any type of module. Simply select the microphone, line and optional modules your application requires. You build the console to fit your precise needs. ■

ACCESSORIES FOR THE BMX III.

Copystands are available for all BMX consoles. There are two styles; the first is designed to be permanently attached to the top of the console, the second, a free-standing version which offers the advantage of positioning copy at an optimum reading distance for each operator.

The copystands are made of natural oak with a semi-transparent, smoke-bronze lucite copyboard.

The BMX III console may be ordered with an overbridge option which spans the top of the standard meter panel. This option provides additional mounting space for peripheral equipment such as routing switchers, remote controls, intercom, status alarm lamps and controls, remote readout displays, etc. The overbridge may be fitted at initial order or may be added to an existing BMX Series console in the field.

The optional turret units are designed to provide an attractive and practical housing for talent control panels and display modules. Microphone buttons, monitor/headphone panels, clocks, and timers are some of the devices which may be installed. The turrets are finished in a durable laminate with solid oak end panels which match the profile of the oak panels on the BMX III meter panel. ■

BMX III MECHANICAL DIMENSIONS

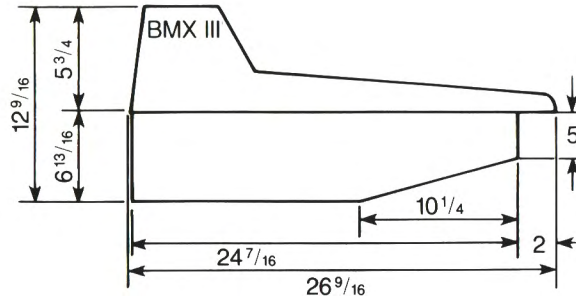

SIDE VIEW

CONSOLE	A	B	C
BMX III-10	32	30½	30¾
BMX III-14	38	36½	36¾
BMX III-18	44	42½	42¾
BMX III-22	50	48½	48¾
BMX III-26	56	54½	54¾
BMX III-30	62	60½	60¾
BMX III-34	68	66½	66¾

NOTE: All Dimensions are in Inches

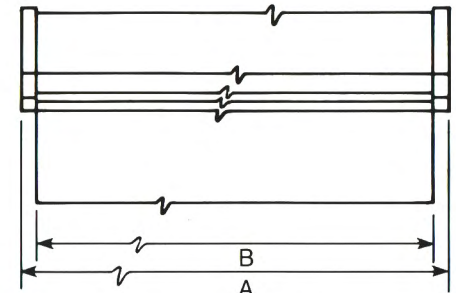

FRONT VIEW

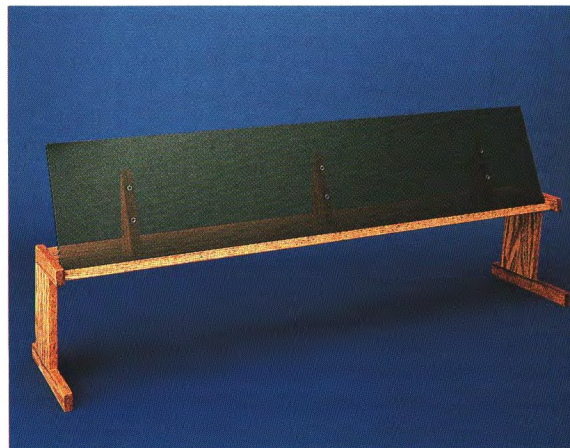
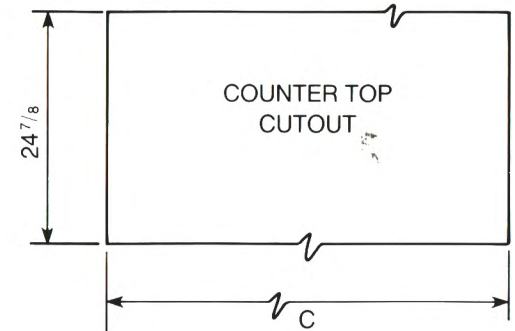

Copy stands are available in fixed or free-standing formats for all BMX consoles.

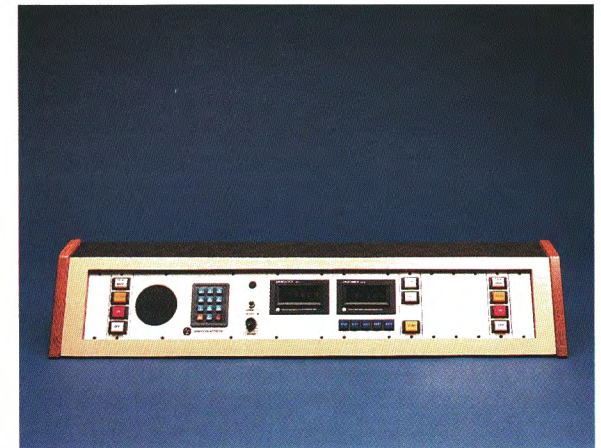

Optional overbridge or turrets give you extra space and they match perfectly with a BMX.

SPECIFICATIONS

MICROPHONE INPUT :

Source Impedance	150 ohms
Input Impedance	1000 ohms minimum, balanced
Input Level Range	Adjustable from -60 dBu to -35 dBu
Input Headroom	Greater than 30 dB above nominal input

HIGH LEVEL INPUTS :

Source Impedance	600 ohms
Input Impedance	Greater than 40K ohms, balanced
Input Level Range	
Line Input	Adjustable from -12 dBu to +8 dBu
Monitor Input	Nominal +4 dBu/+8 dBu
Patch Input	Nominal -10 dBu
Input Headroom	Greater than 30 dB above nominal input levels

MAIN OUTPUTS :

Load Impedance	600 ohms
Source Impedance	30 ohms
Nominal Output Level	+8 dBm, adjustable to +4 dBm
Maximum Output Level	
Line Amplifiers	+28 dBm, 600 ohm load
Send Module	+26 dBm, 600 ohm load

MONITOR OUTPUTS :

MAIN OUTPUTS:

Load Impedance	600 ohms or greater
Source Impedance	30 ohms, unbalanced
Output Level	0 dBu nominal, ± 20 dBu maximum

HEADPHONE OUTPUTS:

Load Impedance	45 ohms or greater
Source Impedance	Less than 4 ohms
Output Level	0 dBu nominal, +29 dBu maximum

FREQUENCY RESPONSE :

Microphone Input to Program Output	+0 dB, -0.9 dB, 20 Hz to 20 kHz
Line Input to Program Output	+0 dB, -0.8 dB, 20 Hz to 20 kHz

NOTES:

- 1) These specifications are for the basic signal paths, per channel, with either or both channels of a stereo pair operating and with 600 ohm loads connected to the program outputs.
- 2) 0 dBu corresponds to an amplitude of 0.775 volts RMS regardless of the impedance of the circuit. It is the *same voltage value* as 0 dBm measured in a 600 ohm circuit. This enables convenient level measurement with meters calibrated for 600 ohm circuits.
- 3) Noise specifications are for a 14-input console (BMX-14) larger consoles will have slightly reduced signal-to-noise ratios due to increased summing amplifier gain. Noise specifications are based upon a 20 kHz bandwidth: the use of a meter with a 30 kHz bandwidth will result in a noise measurement increase of approximately 1.7 dB.

NOISE :

Microphone Input Amplifier	-127 dBu RMS equivalent input noise, 150 ohm source, 20 kHz bandwidth
Line Input Amplifier	-88 dBu equivalent input noise, 600 ohm source, 20 kHz bandwidth
Output noise with one microphone channel ON, fader at -15 dB, input sensitivity at -50 dBu	76 dB below output, reference +8 dB 150 ohm source, 20 kHz bandwidth
Output noise with one line channel ON, fader at -15 dB, input sensitivity at +8 dBu.	80 dB below output, reference +8 dB 600 ohm source, 20 kHz bandwidth
Output noise with no input channels ON	82 dB below output, reference +8 dB, 20 kHz bandwidth

DISTORTION , T.H.D. :

Microphone input to program output	Less than 0.02%, 20 Hz to 20 kHz, -50 dBu input, +8 dBm output into 600 ohm load, 80 kHz meter bandwidth; less than 0.01% at 1 kHz, +28 dBm output
Line input to program output	Less than 0.008%, 20 Hz to 20 kHz, +8 dBu input, +8 dBm output into 600 ohm load, 80 kHz meter bandwidth; less than 0.01% at 1 kHz, +28 dBm output

DISTORTION, I.M. :

Microphone input to program output	Less than 0.008%, -50 dBu input, +8 dBm output into 600 ohm load; less than 0.01% at +28 dBm into 600 ohm load
Line input to program output	Less than 0.005%, +8 dBm input, +8 dBm output into 600 ohm load; less than 0.01% at +28 dBm into 600 ohm load

CROSSTALK :

Interchannel crosstalk	Less than -85 dB at 1 kHz Less than -75 dB at 20 kHz
------------------------	---

Pacific Recorders & Engineering Corp. reserves the right to change specifications without notice or obligation.



PACIFIC RECORDERS & ENGINEERING CORP.

PROGRAM

DIGITIMER

METER

LEFT

RIGHT

If You Didn't Get This From My Site,
Then It Was Stolen From...

www.SteamPoweredRadio.Com

Printed in U.S.A.
© 1988 PR&E



Pacific Recorders & Engineering Corporation
2070 Las Palmas Drive
Carlsbad, CA 92009
(619) 438-3911 Telex: 181777
MCI Mail: 650 285 0799 MCI UW