

# HOW CAPACITORS ARE USED

7B

*RADIO—TELEVISION—ELECTRONICS*



**NATIONAL RADIO INSTITUTE**

**WASHINGTON, D. C.**

**ESTABLISHED 1914**

# STUDY SCHEDULE NO. 7

1. Introduction .....Pages 1-3

This section gives a brief picture of what a capacitor is and the different types in use.

2. How a Capacitor Stores Electricity .....Pages 3-9

You learn about charging a capacitor, the factors affecting capacity, and the voltage rating of capacitors.

3. Typical Capacitors .....Pages 10-17

You study variable capacitors and paper, mica, ceramic, and electrolytic fixed capacitors.

4. How Capacitors Work in AC Circuits .....Pages 18-21

You learn how ac flows in capacitive circuits, and you study the effect of connecting capacitors in series and in parallel.

5. Simple R-C Circuits .....Pages 22-28

Here we take up time-constants, phase, voltage distribution, and impedance in resistor-capacitor circuits.

6. Answer Lesson Questions.

7. Start Studying the Next Lesson.

COPYRIGHT 1957 BY NATIONAL RADIO INSTITUTE, WASHINGTON 16, D. C.

1958 Edition

Printed in U. S. A.

JD7M158

STEAM POWERED RADIO.COM

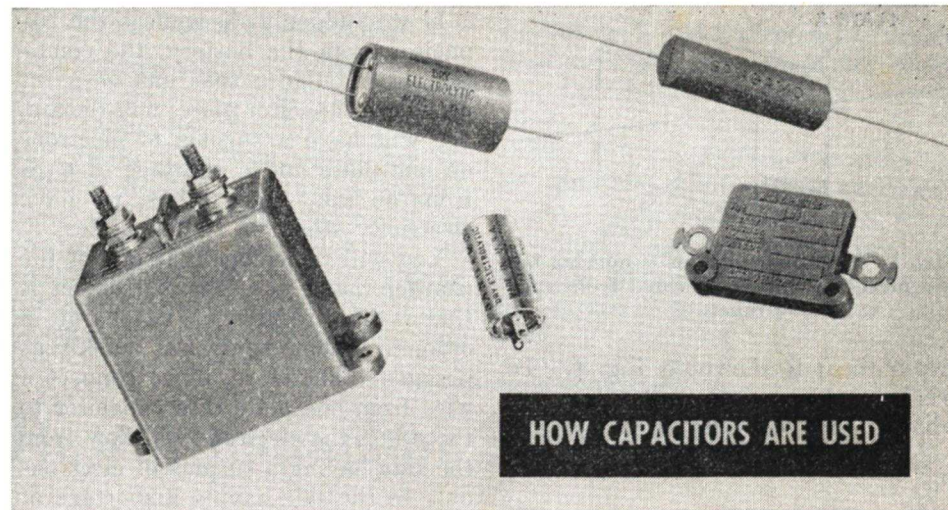

OF THE three major electronic circuit parts, resistors, coils, and capacitors, it would be impossible to pick the one that is the most essential. All three parts are extremely important. In many circuits all three are used together; in some circuits two of the three are used together. When used in combination, these parts are able to perform jobs that one cannot do alone.

In the preceding two lessons, you studied resistors and coils. In this lesson you will study capacitors in detail. After you have completed this lesson, you should have a good understanding of how these three basic parts work. Later, you will see how they are used together.

In many respects a capacitor is the opposite of a coil. You will remember that in an ac circuit with a coil in it, the current flowing in the circuit will lag or follow the applied voltage by 90 degrees. If instead of a coil we put a capacitor in the circuit, the current would lead the voltage by 90 degrees, in other words we would have just exactly the opposite effect. You will see more of this later in this lesson and also find out exactly why it

*Photo above courtesy Sangamo Electric Co.*

is that in a capacitive circuit the current leads the voltage. For the present, let's start this lesson by learning a little about what a capacitor is and some of the fundamentals of how it works.

## WHAT IS A CAPACITOR?

In its simplest form, a capacitor, or condenser, as many old-timers call it, consists of nothing more than two plates separated from each other either by air or by some other nonconducting material placed between them. The material between the two plates, whether it is air, a liquid, or a solid, is called the dielectric. If there is nothing between the plates, but air, we say the capacitor has an air dielectric.

The electrical size of a capacitor is called its capacity. A large capacitor has a large capacity. There are a number of things that affect the capacity of a capacitor, which you will study in a little while.

## HOW A CAPACITOR WORKS

A simple capacitor made of two metal plates with an air dielectric be-

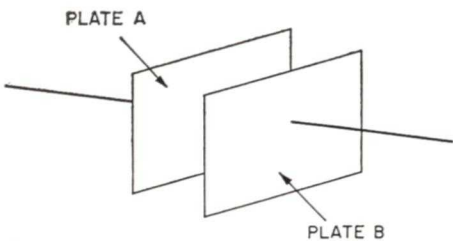

**FIG. 1. A simple capacitor is nothing but two pieces of metal separated from each other.**

tween them is shown in Fig. 1. To see how a capacitor works, let's see what will happen when we connect this capacitor to a battery as shown in Fig. 2.

When the plates of the capacitor are connected to the battery, electrons flow from the negative terminal of the battery into the plate of the capacitor connected to the negative terminal. There will be a surplus of electrons built up on this plate of the capacitor.

You know that one of the characteristics of an electron is that it repels other electrons. Remember the rule of charges, *like charges repel*. Therefore, the surplus electrons on the one plate of the capacitor will repel electrons from the other plate back to the positive terminal of the battery. At the same time, the positive terminal of the battery attracts electrons and pulls them from the plate connected to it, leaving a shortage of electrons on this plate, giving it a positive charge. This positive charge will attract electrons from the negative terminal of the battery to the plate connected to it. Thus, there will be a surplus of electrons on one plate and a shortage of electrons on the other. The electron flow will continue until plate A is just as negative as the negative battery terminal, and plate B is just as positive as the positive battery terminal. When this condition exists we say the capacitor is charged.

If we suddenly disconnect the capacitor from the battery, the condition of unbalance that has been set up on the capacitor plates will remain. We will have a surplus of electrons on one plate and a shortage of electrons on the other. Thus, we have electricity stored in the capacitor.

You will remember that one of the characteristics of a charged object is that it tries to give up its charge in order to become neutral as quickly as possible. Therefore, if we connect a wire from one plate of a capacitor to the other, the electrons will flow from the side having a surplus of electrons over to the side having a shortage of electrons until the number of electrons on the two plates is balanced, and there is no longer a charge on them.

This is a very brief explanation of how a condenser works, how it is charged, and how it can store electricity. We will look into this more thoroughly in the next section of this lesson, but this is enough to give you a general idea of how a capacitor works. Keep in mind that a capacitor can store electricity. Before touching the leads of a large capacitor you should short the leads together with a screwdriver or similar object to be sure the capacitor is discharged, otherwise *you* may discharge the capacitor and receive an unpleasant and possibly dangerous shock!

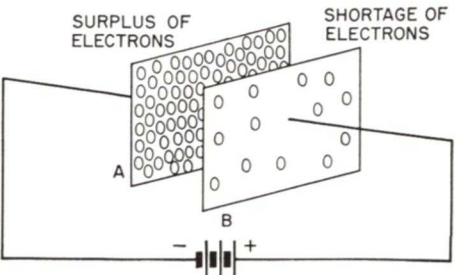

**FIG. 2. When a capacitor is connected to a battery, a surplus of electrons is accumulated on one plate. This forces electrons off the other plate, leaving it with a positive charge.**

**TYPES OF CAPACITORS**

Capacitors can be divided into two types, according to what type of material (called the dielectric) separates the plates. One type has an air dielectric, and the other has a solid or liquid dielectric. When we say a capacitor has an air dielectric, we simply mean that there is nothing but air between the plates of the capacitor. When we say a capacitor has

a solid or liquid dielectric we mean that some insulating material other than air has been inserted between the plates.

You will see typical examples of all these types of capacitors later; you will learn more about them, what they look like, and where they are used in electronic circuits; but first let us learn more about how they work.

**How A Capacitor Stores Electricity**

In considering a capacitor, you may at first wonder how a capacitor can be used in an electronic circuit because there is no complete circuit through the capacitor. In the sketch of the simple capacitor shown in Fig. 1 you can see that the two plates of the capacitor do not touch each other. There is a space between the two plates so that the electrons on one plate cannot normally flow from one plate to the other.

When we connected a battery to a capacitor we saw that the plates of the capacitor became charged, one plate picking up a surplus of electrons and the other losing electrons so that it had a shortage.

The usefulness of a capacitor depends upon its ability to store electricity or to hold a charge. Let's learn a little more about how a capacitor is charged, so we can better understand some of its more important uses.

**CHARGING A CAPACITOR**

A capacitor cannot be charged instantly. It takes time for the charge to build up after the electrons start to flow from the negative terminal of the battery into one plate of the capacitor and from the other plate to the posi-

tive terminal of the battery. The length of time that it takes depends upon two things, the size of the capacitor and the amount of resistance in the circuit.

You might think that there was no resistance in the circuit we have shown in Fig. 2. However, this is not the case. There is resistance in the leads used to connect the capacitor to the battery, and in addition there is the internal resistance of the battery itself. These two resistances will limit the rate at which the capacitor can charge.

Because it does take some time to charge a capacitor, there will be a current flowing in the circuit shown in Fig. 2 when the capacitor is first connected to the battery. This current will flow as long as the battery is charging the capacitor. The longer it takes the battery to charge the capacitor the longer there will be a current flowing in the circuit. Therefore, you can see that even though the electrons cannot cross from one plate of the capacitor to the other plate there is a current flow in the circuit at least for the short time it takes to charge the capacitor.

One question that sometimes comes up when considering a charged capacitor is whether or not the capacitor

has any more electrons than it has in the discharged state. The answer to this question is *no*—the capacitor will have the same number of electrons whether it is charged or discharged. The only difference is that when a capacitor is discharged there is no charge on any of the atoms making up the metal on either plate. In other words, each atom has enough electrons to exactly neutralize the charge in its nucleus. However, when the capacitor is charged, some of the electrons are moved off one plate so there is a shortage of electrons on that plate, and the same number of extra electrons are forced onto the other plate, so there is a surplus of electrons on it. Thus the total number of electrons in the material making up the capacitor does not change.

**The Amount of Charge.** The charge on a capacitor depends upon the battery voltage used to move electrons onto one plate and away from the other. A battery with a higher voltage can exert more force on the atoms making up the capacitor plates and thus move more electrons than a battery with a lower voltage could. However, there are other things that affect the charge we can store in a capacitor. The electrical size of the capacitor is just as important as the charging voltage. The electrical size of the capacitor is called the *capacity* of the capacitor. Now let's see what we mean by capacity.

## CAPACITY

The term capacity is used to describe the electrical size of a capacitor. It is used in the same way as inductance is used to describe the electrical size of a coil, and resistance is used to indicate the electrical size of a resistor.

Just as the henry is the unit of inductance and the ohm is the unit of

resistance, the "farad" (pronounced FAIR-ad) is the unit of capacity. It was named after the scientist Michael Faraday, who did a great deal of the early work with capacitors. The capacity of a capacitor is a measure of its ability to store electricity. A capacitor with a high capacity can store more electrons than a capacitor with a lower capacity. Thus the capacity of a capacitor indicates its electrical size to the technician just as the resistance of a resistor indicates electrical size of the resistor.

We can express the capacity of a capacitor in terms of charge and voltage. The capacity of a capacitor is equal to the charge it will take divided by the voltage used to put that charge on the capacitor. You will remember that the "coulomb" is the unit of charge. A coulomb represents a certain quantity of electrons. If a current of 1 ampere flows in a circuit for one second, the number of electrons moving past a given point in the circuit represents one coulomb of electricity. If when we connect a one-volt battery across a capacitor we can store a charge of 1 coulomb in the capacitor, its capacity is 1 farad. If the capacitor would take a charge of 2 coulombs with an applied voltage of 1 volt, the capacity would be two farads. The farad actually represents an extremely large capacity. It is so large in fact that it is never used in electronics. Let us look at the smaller units of capacity that are used.

**Units of Capacity.** Since the farad is so large a unit, capacity in electronic circuits is usually expressed in smaller units, which are fractions of a farad. They are:

1. The *microfarad*, which is equal to one-millionth of a farad. Microfarads are abbreviated in several ways, the most common abbreviations are  $\mu\text{f}$ ,  $\text{mf}$ , and  $\text{mfd}$ .

2. The *micro-microfarad*, which is equal to one-millionth of a microfarad. It is abbreviated  $\mu\mu\text{f}$ ,  $\text{mmf}$ , and  $\text{mmfd}$ .

Because all six abbreviations are frequently found in electronics, you should learn them all. The letter  $\mu$  is the Greek letter "mu", which is pronounced MEW.

You should have no difficulty remembering that the prefix "micro" means one-millionth because you have already run into this several times previously. You will remember that the microampere is one-millionth of an ampere and the microhenry is one-millionth of a henry. A microfarad is one-millionth of a farad and a micro-microfarad is one-millionth of a microfarad.

Sometimes it is necessary to change from microfarads to micro-microfarads and vice versa. To change from microfarads to micro-microfarads you simply multiply by 1,000,000. In other words, a capacitor that has a capacity of 5 microfarads has a capacity of 5,000,000 micro-microfarads. You simply add six zeros. A capacitor that has a capacity of .0005 microfarads has a capacity of 500 micro-microfarads.

To convert from micro-microfarads to microfarads you divide by a million, and this can be done by moving the decimal point six places to the left. To do this, you can add zeros to the left. Thus, 100 micro-microfarads can be written 000,000,100 micro-microfarads. All the zeros to the left of the one have no meaning. To convert this value to microfarads, move the decimal point six places to the left and you will get 000.0001 microfarads. The zeros preceding the decimal have no meaning so they can be dropped and you have .0001 microfarads or .0001 mfd.

No doubt as you were reading the preceding section you noticed how long the words microfarad and micro-

microfarad are. Technicians have shortened these words. The word microfarad is frequently abbreviated to "mike". Thus if you went to a wholesaler to buy a 2-microfarad capacitor you would probably simply say "I want a 2-mike capacitor". Micro-microfarads are shortened to micromikes.

Another abbreviation is as follows: Instead of saying decimal point, zero, zero, one microfarads to identify a .001 mfd capacitor technicians usually say "point double oh one mike". Similarly for .00025 they would say "point triple oh two five" mikes.

## FACTORS AFFECTING CAPACITY

You already know that some electronic circuits use capacitors whose capacity can be changed. You saw an example of this in the receiver you studied where a 2-gang tuning capacitor was used. As the receiver is tuned across the broadcast band, the capacity of each section of the tuning capacitor changes.

There are a number of factors that affect the capacity of a capacitor. So you will understand how the capacity of a variable capacitor is changed and also to help you understand the other capacitors you will encounter in electronics work, we will now discuss some of the factors affecting capacity.

**1. Area of Plates.** The capacity of a capacitor depends upon the area of the plates. Thus, if the area of each plate of a simple capacitor such as the one shown in Fig. 1 is doubled, the capacity would be doubled.

There are other ways in which the area can be increased in order to increase the capacity. For example, look at the capacitor shown in Fig. 3A. Notice that instead of a simple capacitor made up of two plates as we had in Fig. 1, here we have three plates. Two of the plates, marked A1

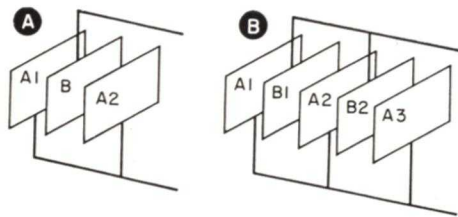

FIG. 3. Adding plates to a capacitor increases the capacity.

and A2, are connected together. If we start off with a capacitor having the two plates A1 and B, and then add the plate A2 to the capacitor, we would double the capacity. You can see why this is so when you consider what happens to the area of the plates when we add plate A2. Let's assume that each plate has an area of one square inch. Thus the area of plate A1 opposite plate B is one square inch. When we add plate A2, we will have the areas of A1 and A2 exposed to both sides of B. Thus the effective area of the plates is doubled and therefore the capacity is doubled.

Additional plates can be added as shown in Fig. 3B. Adding additional plates to a capacitor actually increases the area of the plates, which in turn increases the capacity.

In considering the area of the plates, we must consider only the overlapping area. For example, if we have a capacitor made up of two plates each having an area of 1 square inch, and positioned as shown in Fig. 4A, we will have a certain capacity. However, if without changing the size of the plates we move them as shown in Fig. 4B, the capacity will be reduced, because the overlapping area of the plates is reduced. The part of plate A that is not directly opposite part of plate B will have little or no effect on the capacity. Similarly the part of plate B that is not opposite part of plate A, will have little or no effect.

This is the principle that is used in variable capacitors. Here a number of plates are arranged so that one section of plates is movable and can be made to overlap more or less of the other section, thus exposing larger or smaller areas of the two sections to each other.

**2. Spacing.** The distance between the plates of a capacitor will also affect the capacity. We already pointed out that if you cut the space between the plates of the capacitor in half, you will actually get four times as much capacity. We say that capacity varies inversely as the square of the distance between the plates. In other words, if you double the space between the plates you will have one-quarter of the capacity, if you triple the space you will have one-ninth of the capacity. This is due to the fact that when the repelling effect of the electrons on one plate and the attracting force of the shortage of electrons on the other plate must act over a greater distance, they are not able to drive as many electrons out of the one plate of the capacitor and pull as many onto the other plate. As a result, the capacitor is not able to store as great a charge. You already know that the capacity of a capacitor is equal to the charge in coulombs divided by the voltage required to give that charge. Thus, if the charge a capacitor can hold is reduced, the capacity will go down. Moving the plates farther apart will reduce the charge that you can get on a capacitor for a given applied voltage. Conversely, bringing the plates



FIG. 4. Only the overlapping areas of the plates affect the capacity of a capacitor.

closer together will increase the charge you can get on a capacitor for a given applied voltage.

**3. Dielectric.** We have already mentioned that the type of dielectric used between the plates of the capacitor has an effect on the capacity. If instead of air between the plates we place a piece of mica, paper, or ceramic material, the capacity will be increased. As a matter of fact, if we slide a piece of mica between the plates of a capacitor so that the mica exactly fills up the space we will find that the capacity will increase somewhere between 6 and 8 times.

### DIELECTRIC CONSTANT

In the preceding section we mentioned that inserting a piece of mica between the plates of a capacitor would increase the capacity somewhere between 6 and 8 times. The amount that a certain material will increase the capacity when used as a dielectric, compared to the capacity when air is used, is called the "dielectric constant" of the material. In other words, the dielectric constant tells us the number of times that the capacity will be increased by inserting a certain material between the plates of a capacitor. Actually, the dielectric constant is based on the number of times the capacity would be increased over the capacity we would have if the dielectric were a perfect vacuum. However, air between the plates affects the capacity very little. The capacity is practically the same with an air dielectric as it would be with a perfect vacuum between the plates so that we say that the dielectric constant of air is 1, in other words it is the same as a vacuum between the two plates.

Different materials have different dielectric constants. Paper has a dielectric constant of somewhere be-

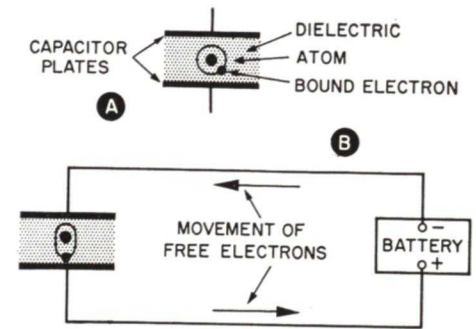

FIG. 5. Electrons in the dielectric are bound to their atoms, but their paths are shifted when a battery is connected across the capacitor, so that they come closer to the positive plate, thus transferring the effect of the extra electrons on the negative plate.

tween 1.5 and 3, depending upon the grade of paper. Mica has a dielectric constant between 6 and 8. Different types of oil have dielectric constants from about 2 up to about 10. The ceramic materials used in ceramic capacitors have a wide range of dielectric constants going up to as high as about 1500. You can see from this why it is possible to make ceramic capacitors with large capacities in small physical sizes.

We already mentioned that the effect of a dielectric is to increase the capacity of the capacitor. If there were a perfect vacuum between the plates of a capacitor, electrons flowing into one plate of the capacitor would place a negative charge on this plate and electrons flowing from the other plate would place a positive charge on it.

However when we place any dielectric material, which of course includes air, between the plates of the capacitor, the electrons on the negative plate of the capacitor distort the atoms of the material between the plates. Before the plates of the capacitor are charged, the atoms in the dielectric will be in their normal state with the electrons revolving around

the nucleus as shown in Fig. 5A. However, when the electrons flow onto the negative plate of the capacitor, they will tend to repel the electrons in the dielectric. Since the dielectric is an insulator, the electrons are not free, but are bound to the atoms; however the repelling effect of the electrons on the negative plate will shift the path of the electrons in the dielectric so that the path around the nucleus will be like that shown in Fig. 5B. Notice that the electrons are pushed away from the negative plate and towards the positive plate. As these electrons move closer to the positive plate, they tend to repel the electrons on the positive plate. Because the electrons from the atoms in the dielectric move over towards this plate of the capacitor, the dielectric has the effect of reducing the space between the plates. This places the negative charge very close to the positive plate and drives many more electrons off the positive plates of the capacitor than could be removed if the two plates were in a vacuum.

As we mentioned, air acts almost like a perfect vacuum. There is very little of this effect occurring when the dielectric is air. However, with materials of a higher dielectric constant this effect is more pronounced. This is particularly true in the case of ceramic materials where there is considerable distortion of the atoms in the dielectric so that the net effect is to get the same result as you would get by having the plates of the capacitor practically touching. Of course, in a practical case you can't have the plates practically touching, because they would probably short together and then the capacitor would be of no value. However, by using the right dielectric we get just as much capacity as we would with the plates practically touching and at the same

time the dielectric between the plates holds the plates rigid and reduces the possibility of the plates accidentally shorting together.

## VOLTAGE RATINGS

We mentioned previously that the charge that can be placed on a capacitor depends upon the electrical size or the capacity of the capacitor and also on the voltage used to place the charge on the capacitor. You might think from this that you could put more and more charge on a capacitor simply by increasing the voltage higher and higher. However, this is not the case because there is a limit to how much voltage can be applied to a capacitor.

Manufacturers design capacitors with a certain spacing between plates. If the plates are put very close together, you can not put a very high voltage on the capacitor, because the electrons forced onto the one plate of the capacitor would jump right across the space between the plates to reach the other plate of the capacitor which has a shortage of electrons. Once this happens current will flow across the point where the capacitor breaks down, at least until you eliminate the short by shutting off the power. Sometimes when the electrons jump across the capacitor in this way the capacitor is permanently damaged.

**Working Voltage.** When a manufacturer designs a capacitor he designs it for use in a circuit with a certain maximum operating voltage. The voltage is marked on the capacitor and is usually called the *working voltage*. The capacitors you will find in small pieces of electronic equipment such as radio and TV receivers will usually have a working voltage somewhere between 200 and 600 volts. Some of the capacitors in a TV re-

ceiver may have a working voltage as low as 200 volts. These capacitors are used in circuits where the operating voltage does not exceed 200 volts. Others used in higher voltage circuits may have a working voltage of 400 volts and still others used in circuits with a voltage still higher may have a working voltage of 600 volts or more.

One point to keep in mind when servicing electronic equipment is that the manufacturer of the equipment usually uses as low a working voltage as possible in order to keep the cost of the equipment low. However, there is no reason why a capacitor with a higher working voltage cannot be used providing there is room to do so.

**Peak Voltage.** Sometimes you will find a capacitor with two voltage markings on it. It may be marked "working voltage 450 volts, peak voltage 525 volts". This type of marking is usually found on an electrolytic capacitor designed for use as a filter capacitor in a power supply. Here you know that the output of the rectifier in the power supply is pulsating dc. Thus the actual voltage at the output of the rectifier is not constant. If the dc output voltage from the power supply is 450 volts, during part of the time when the pulses from the rectifier tube reach their peak, the voltage will exceed this value. As long as this voltage peak does not exceed 525 volts, a capacitor marked with a 450-volt working voltage and a 525-volt peak voltage will work satisfactorily.

Some manufacturers do not mark electrolytic capacitors in this way. They simply mark them with the working voltage with the assumption that the peak voltage will not exceed a safe value.

## SUMMARY

There are a number of important points that you should remember from this section of the lesson. First, remember that the basic action of a capacitor depends upon its ability to store an electric charge. Also remember that there is no complete circuit through a capacitor, but current will flow in a circuit in which a capacitor is connected while the capacitor is being charged and while it is being discharged. Remember that a capacitor is not charged instantly, but there is some time involved in charging a capacitor. The actual time it takes to charge a capacitor fully will depend upon the capacity and the resistance in the circuit.

Remember that the electrical size of a capacitor is measured in farads, but the farad is such a large unit that the practical values are the microfarad, which is a millionth of a farad, and the micro-microfarad, which is a millionth of a microfarad.

The capacity of a capacitor depends upon the area of the plates, the spacing between the plates, and the dielectric between the plates.

The dielectric constant of the material is a number which tells you the number of times the capacity of a capacitor will be increased when this type of material is placed between the plates of the capacitor. Different materials have different dielectric constants, one of the highest is ceramic which has a dielectric constant up as high as 1500.

The voltage rating of a capacitor tells you the maximum safe voltage that you can apply to a capacitor. Capacitors having a higher voltage rating can always be used in replacing a defective capacitor in a piece of electronic equipment if there is room.

# Typical Capacitors

You have already learned that there are many different types of capacitors used in electronic equipment. However, one thing that you should keep in mind is that although there are many different types of capacitors, the basic action of all capacitors is the same. In other words, a paper capacitor works in exactly the same way as a mica capacitor or an air capacitor. The basic operation of a capacitor depends upon its ability to store a charge. All capacitors, regardless of type, can store a charge. Of course, some capacitors can store more charge than others because they have a greater electrical size. In this section you will see that there is a reason for having these different types of capacitors, and also you will learn more about the common types of capacitors that you will encounter in electronics work.

## VARIABLE CAPACITORS

A typical variable capacitor is shown in Fig. 6. This capacitor is actually two capacitors coupled by a common shaft, and as you know this type is called a two-gang capacitor. In some receivers you will find 3-gang capacitors, and in some old sets and in some communications receivers you will find 4-gang capacitors. Sometimes all sections are identical; sometimes you will find that one section has smaller plates than the others.

Each section of a variable capacitor is made up of two sets of plates. The one set of plates that do not move are all connected together and insulated from the capacitor frame. These plates are called the stator plates, in other words, the stationary plates. The other set of plates are connected directly to the shaft and to the ca-

pacitor frame. These plates rotate and hence are called the rotor plates. Since these plates are connected directly to the capacitor shaft and to the frame, if you mount the capacitor on a metal chassis, the plates are automatically connected to the chassis. This does not present any problem, because in most circuits where a capacitor of this type is used, it is desirable to connect one set of plates to the chassis. The chassis acts as a ground or common connection for all rf (radio frequency) circuits.

These are two different types of plates found in variable capacitors. One type of plate is called the straight line *capacity* type; the other is called the straight-line *frequency* type. An example of the straight-line frequency type of plate is shown in Fig. 7. Notice that in A of Fig. 7 the plates are completely separated so that the capacity is at a minimum. Actually there will be some capacity, because even though the plates are not meshed, the ends of the plates of the rotor have a certain capacity to the ends of the plates of the stator. In B the capacitor plates have been rotated through one eighth of a turn and the

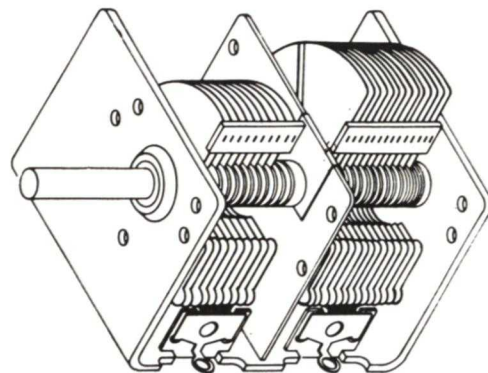

FIG. 6. A variable capacitor.

Courtesy Insuline Corp. of America

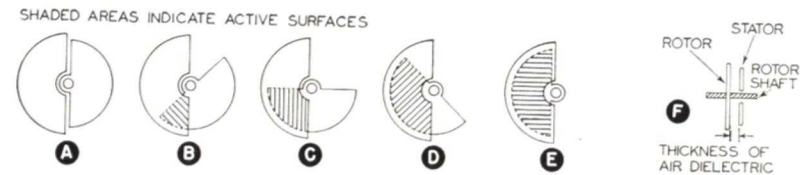

FIG. 7. How a variable capacitor with straight-line capacity plates works.

overlapping area of the two sets of plates is one quarter of the total area. We now have approximately one quarter of the total capacity. As the capacitor is turned another eighth of a turn, from position B to position C, so that it has completed a quarter turn, one-half of the area of the plates is overlapping and we have one half of the total capacity. Similarly, when the capacitor has been moved to three eighths of a turn, three-quarters of the area is overlapping and we have three quarters of the total capacity, and finally with a half turn the entire two areas are completely overlapping and we have maximum capacity.

There is another type of plate that is called the straight-line frequency type. Here the plates are shaped as shown in Fig. 8. Now when the plates are moved from position A to position B, less than a quarter of the area is overlapping even though the capacitor has gone through an eighth of a turn and we have less than a quarter of the total capacity.

Similarly when it is moved to position C, although the capacitor has been turned through a quarter of a turn, less than half of the two areas are overlapped and we will have less than half the total capacity. However, the increase in capacity obtained

by rotating the capacitor from B to C is greater than was obtained in rotating it from A to B because the increase in overlapping area is greater. Similarly we get a still greater increase in capacity in going from C to D and an even greater increase in capacity in going from D to E.

The reason for using this type of capacitor is that at high frequencies it takes a smaller change in capacity to give a given frequency change than it does at low frequencies. Therefore if you use the straight-line capacity type of capacitor in a receiver, stations at the high-frequency end of the dial will be all squeezed together, and the stations at the low frequency end will be spread out. This makes it difficult to tune in stations at the high-frequency end of the dial. With the straight-line frequency type, however, the different frequencies are spread evenly across the dial of the receiver so that it is just as easy to tune in a station at the high end of the dial as one at the low end of the dial. Most modern broadcast receivers use the straight-line frequency type of capacitor because it is so much easier to tune the receiver.

A single-section tuning capacitor such as might be found in a radio frequency transmitter or any other

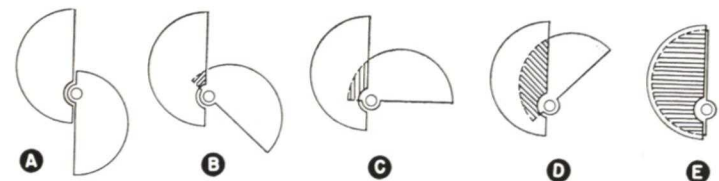

FIG. 8. How a variable capacitor with straight-line frequency plates works.

device where a variable capacitor is needed and high voltage is present is shown in Fig. 9. Notice that this capacitor is basically similar to one section of the capacitor shown in Fig. 6. The big difference is that the spacing between the plates is greater. The greater spacing is needed in high-voltage circuits to avoid arcing between the plates. Arcing is simply a flash-over that occurs where the voltage is so high that the electrons are able to jump from one plate of the capacitor to the other.

**Trimmer Capacitors.** Another type of variable capacitor is the trimmer capacitor. There are two types of trimmers, one with an air dielectric and one with a mica dielectric. The air dielectric type of trimmer is made exactly like a variable capacitor, the only difference is that it is a very small capacitor. The mica trimmer, however, uses an entirely different type of construction. A typical mica trimmer is shown in Fig. 10. Here the spacing between the plates is adjusted by means of an adjusting screw. The adjusting screw tightens down on the top plate and moves it closer to the bottom plate. In some capacitors the adjusting screw is insulated from both the top and bottom

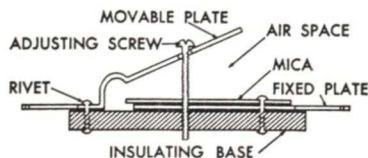
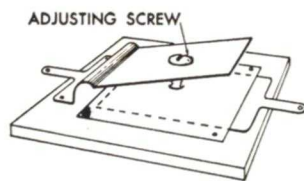

FIG. 10. A typical trimmer capacitor.

plates, but in others the screw is allowed to touch the top plate. Capacitors of this type are found in most circuits where 2-gang variable capacitors are used. These trimmers are needed in order to compensate for other effects in the circuit which a manufacturer cannot economically control.

Trimmer capacitors are also used in i-f transformers. You will remember that you use i-f transformers in a superheterodyne receiver. Trimmer capacitors are used in conjunction with the coils in the i-f transformer to adjust the combination to the intermediate frequency. You will learn more about this in later lessons.

## PAPER CAPACITORS

A typical paper capacitor is shown in Fig. 11. As you can see, it simply looks like a solid tube with leads coming out of each end.

A paper capacitor is made by taking two sheets of tinfoil and placing a sheet of paper between them as shown in Fig. 12A. The tinfoil and the paper are then rolled as shown in Fig. 12B until they are shaped like Fig. 12C. Wire leads are then attached to the foil sheets that protrude from each end of the capacitor. The

capacitor is then encased in a cardboard case and wax or some other sealing compound is poured into both ends. In some cases the paper and tinfoil are impregnated with oil before the capacitor is sealed. This type of capacitor is called an oil-filled paper capacitor and usually it is a somewhat better capacitor than an ordinary paper capacitor that is not impregnated with oil, because there is less chance for moisture to get in.

Some paper capacitors are completely encased in a molded ceramic type of material. This type of capacitor is called a molded capacitor and it is completely sealed so that moisture cannot seep into the capacitor. When moisture seeps into a paper capacitor the usual result is that the capacitor breaks down because the water produces a leakage path across which electrons can travel. Sometimes the leakage path has a very high resistance and does not appreciably affect the performance of the capacitor in the circuit. However, in some circuits even a small amount of leakage cannot be tolerated.

Paper capacitors are made in a wide range of sizes. You will encounter paper capacitors as small as .0005 mfd and as large as 1 mfd or 2 mfd. Paper capacitors can be made in a larger size, but it is usually more economical to make other types when the capacity needed in the circuit exceeds .5 mfd.

**Defects.** Since you are training as an electronic technician, one of your chief concerns with capacitors will be the defects that occur in them. There are a number of types of defects that can occur in paper capacitors. As we have mentioned, moisture

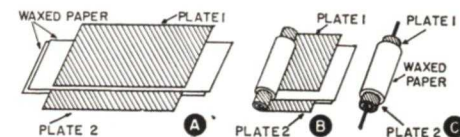

FIG. 12. How a paper capacitor is made.

can seep into the capacitor, resulting in leakage from one plate to the other or in eventual breakdown in the paper insulation so that for all practical purposes one plate is touching the other. Of course, when this happens, the capacitor can no longer store a charge, it acts just as if there were a wire connected between the two leads of the capacitor.

It is usually not too difficult to identify a completely shorted capacitor, but one that has a high leakage may cause almost as much trouble as a shorted capacitor and it is much more difficult to find. There is no such thing as a perfect capacitor. There is some leakage between the plates of all capacitors. However a good paper capacitor will usually have a leakage resistance of several thousand megohms. When the leakage resistance drops below this figure it is a sign that the capacitor is deteriorating. In some circuits a leakage resistance as low as 2 or 3 megohms can be tolerated and the circuit may work perfectly, but in other circuits a capacitor that may have a leakage resistance as high as 10 or 20 megohms may be totally unusable. It is too early for you to try to distinguish between these cases, the important thing for you to remember at this time is that leakage between the plates and direct shorts between the plates of capacitors are two defects that paper capacitors can develop.

Another defect found in paper capacitors is an open. The open is usually where one of the leads breaks loose from the tinfoil. Sometimes the lead will pull right out of the ca-



FIG. 11. A typical paper capacitor.

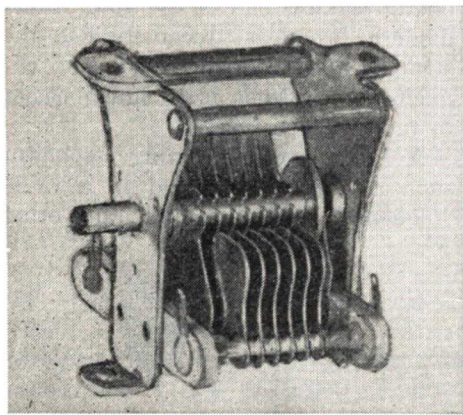

FIG. 9. A single-section variable capacitor of the transmitting type.



capacitor, and of course this is easy to spot because you can see it. But in most cases the break will be inside the capacitor so you cannot see it and you will have to rely on the way in which the circuit performs to give you a clue that this is a possible cause of trouble.

Another defect found in paper capacitors is an intermittent defect. Part of the time the capacitor will operate normally, but other times it may short, or it may open. Again, we do not expect you to be able to find these defects at this time, the important thing is to remember that these types of defects can and do occur.

### MICA CAPACITORS

Mica capacitors are somewhat larger physically than paper capacitors of equal capacity. However, mica is used in some capacitors that are to be used in high-frequency circuits. Mica capacitors are also used in the rf signal circuits of transmitters. Mica capacitors are made with capacities ranging from about 10 mmf to approximately 10,000 mmf. Some mica capacitors found in transmitters are designed for operation in circuits where the voltages are extremely high; capacitors with working voltages of 5000 volts are quite common.

The construction of a mica capacitor is shown in Fig. 13. Notice that there are simply two sets of plates, and that the plates are separated by thin sheets of mica placed between the metal plates. Because mica is brittle, this type of capacitor cannot be rolled into a tube like a paper capacitor and therefore most mica capacitors are rectangular in shape. The plates and the mica are enclosed in a ceramic or Bakelite case that is molded over the unit.

Mica capacitors seldom break down. About the only defect that they ever

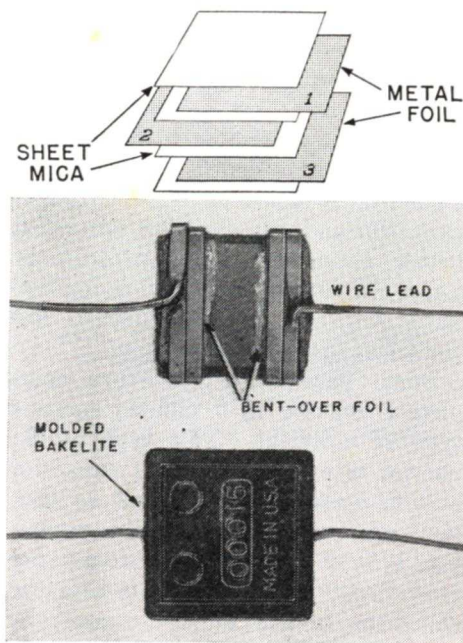

FIG. 13. How a mica capacitor is made.

develop is a short. Occasionally one of the leads will pull loose and the capacitor will open, but it is very rare to find any defect at all in a mica capacitor. In spite of the fact that mica capacitors are almost trouble-free, they are disappearing in low-voltage circuits because they are more expensive than ceramic capacitors which are used in many low voltage circuits in place of mica capacitors. However, mica capacitors are still used almost exclusively in transmitting equipment.

### CERAMIC CAPACITORS

There are two types of ceramic capacitors found in electronic equipment. One is the tubular type, and the other is the disc type. Examples of each type are shown in Fig. 14.

Tubular ceramic capacitors are made in small sizes, from about 1 mmf up to about 1500 mmf. Larger sized capacitors are made in the form of

disks. Typical sizes of disc capacitors range from about .001 to .01 mfd.

One of the characteristics of disc type ceramic capacitors, is that they have a rather wide tolerance. By this we mean that it is difficult to make a capacitor of this type and hold the capacity to one particular value. Thus if you order a .001-mfd disc type ceramic capacitor, the capacity may actually be anywhere from .001 up to as high as .005 mfd. There are many circuits in which having too large a capacitor does not make any difference, so this type of capacitor can be used. However, in circuits where it is important that you have an exact value of capacity, the disc type ceramic is not suitable.

Tubular ceramic capacitors are made to closer tolerances. Usually the manufacturer specifies the tolerance right on the capacitor. In most cases a tubular ceramic capacitor is made so that the capacity is within 5% or 10% of the rated value. Some ceramic capacitors are made with a +

tolerance. By this it is meant that the capacity will never be smaller than the value indicated, but it may be somewhat larger than the exact value specified.

Tubular ceramic capacitors are found in most electronic equipment and usually have a voltage rating of about 500 volts. Special tubular capacitors having voltage ratings up to about 3000 volts can be obtained. Most disc-type capacitors have a voltage rating of about 500 volts, but this type is also available with a higher voltage rating. Some ceramic capacitors are available for use in the high-voltage supply of television receivers with a voltage rating of as much as 30,000 volts. These capacitors usually have a capacity of about 500 mmf.

**Defects.** Occasionally a lead will break off a ceramic capacitor, but other than this, they seldom open. Ceramic capacitors, particularly the disc type, do short sometimes; shorted capacitors are not difficult to locate. A low resistance reading across any capacitor indicates either that there is something connected across the capacitor causing the reading, or else the capacitor itself is defective.

### ELECTROLYTIC CAPACITORS

Probably the type of capacitor that you as a technician will have the most to do with is the electrolytic capacitor. This is not because they are used more than all other types, but simply because they cause more trouble than any other type. A great many of the defects that occur in electronic equipment can be traced to defective electrolytic capacitors.

There are two types of electrolytic capacitors, dry and wet. The wet type is seldom found in modern electronic equipment—almost all electrolytic capacitors are dry.

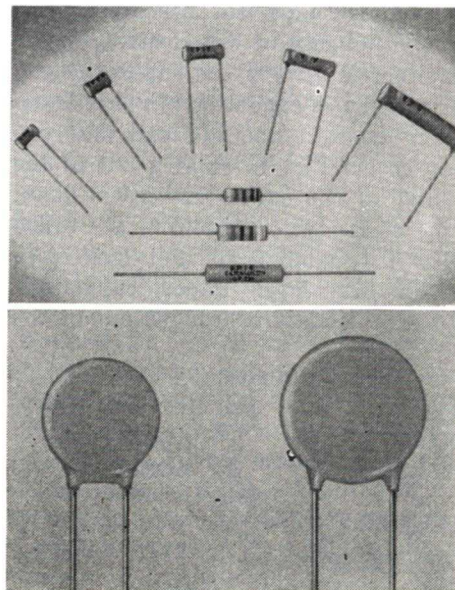
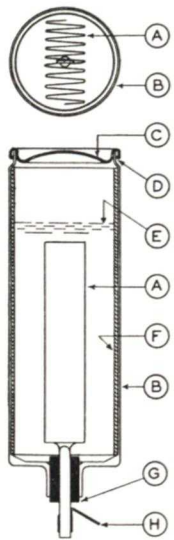

FIG. 14. Two types of ceramic capacitors—tubular and disc.

Courtesy W. S. Hill Co.



**FIG. 15. Top and side views of a typical wet electrolytic capacitor.**

**A. Anode, a plain or etched aluminum foil sheet folded in a zig-zag or crimped manner and riveted to a support rod.**

**B. Cathode, an aluminum can.**

**C. Aluminum cover.**

**D. Semi-porous gasket under cover, which prevents leakage of liquid electrolyte yet allows gases to escape.**

**E. Level of electrolyte.**

**F. Insulating material, which prevents short circuits between anode and cathode.**

**G. Insulating gasket which separates anode terminal from cathode and seals container at this point.**

**H. Connection to anode.**

The basic principle of the two types is the same. The operation of both types depends upon the formation of a coating of aluminum oxide on one plate of the capacitor. This plate is called the anode and must always be connected to the positive side of the circuit.

In the wet electrolytic capacitor an aluminum plate, which is the anode, is placed inside of a metal can, but is insulated from the can. The can is filled with a chemical solution, called an electrolyte, and then the unit is sealed as shown in Fig. 15. The chemical action that occurs inside the capacitor produces a thin coating of aluminum oxide on the anode. The aluminum oxide film acts as the dielectric, and the surface of the chemical solution which is in contact with the dielectric film is the other plate. The metal can acts as a container and a connection to the chemical solution. The metal can forms the negative lead.

A dry electrolytic is made of two plates with an electrolyte in paste

form placed between the two plates as shown in Fig. 16. The anode plate is treated chemically before the capacitor is assembled to produce a coating of aluminum oxide on the surface of the plate. The aluminum oxide then acts as the dielectric, as in the case of the wet electrolytic capacitor and the paste electrolyte acts as the other plate of the capacitor. The plate marked the cathode is the means of making a contact to the paste.

**Polarity.** Electrolytic capacitors have polarity. This means that they can be used only in circuits having dc or pulsating dc. The plate called the anode must always be connected to the positive side of the voltage source and the plate called the cathode must always be connected to the negative side of the voltage source. If an electrolytic (technicians frequently shorten electrolytic capacitor to "electrolytic") is connected into the circuit backwards it will act like a low resistance, and a high current will flow through the capacitor, destroying it.

The polarity of wet electrolytic capacitors is always the same, the can in which the capacitor is made is always negative and the lead that you can see in Fig. 15 coming out of the center of the can is always positive. Dry electrolytic capacitors are rolled into a tubular form and look very much like large paper capacitors. Flexible leads are brought out of the

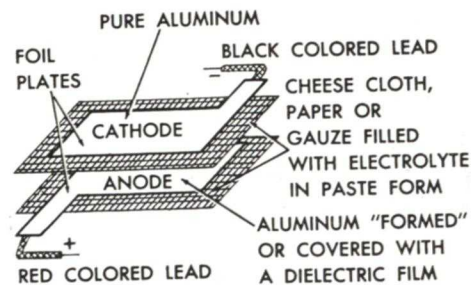

**FIG. 16. How dry electrolytics are made.**

ends of the capacitor and the polarity of the leads is shown either by marking one end with a + sign and the other end of the capacitor with a - sign or by using a wire of one color as one lead and a wire of another color as the other lead. The polarity is thus identified by the color of the leads. Usually a black wire is used to identify the negative lead and a red wire to identify the positive lead.

Electrolytic capacitors can be made with very large capacities. Capacities of several hundred mfd are quite common. However, the working voltage of an electrolytic is quite critical. If an electrolytic capacitor is used in the circuit where the working voltage is exceeded, the chances are that the capacitor will soon break down. Electrolytic capacitors are made with voltage ratings as low as about 10 volts and as high as about 600 volts.

**Defects.** As we mentioned previously, most electrolytic capacitors manufactured today are dry electrolytic capacitors. These capacitors deteriorate, particularly if they are not put into use. An electrolytic capacitor that has been unused for six months or more should be *formed* before the capacitor is put into service. An electrolytic can be formed by placing a low voltage on the capacitor and gradually increasing the voltage until it is equal to or slightly exceeds the rated working voltage of the capacitor. If a 450-volt capacitor that has been sitting around unused for six or seven months is simply installed in a circuit, and has full 450 volts applied to it without first being formed, the chances are that it will short, and the capacitor will be destroyed.

Electrolytic capacitors also deteriorate with use. The moisture in the

electrolytic will slowly escape from the capacitor and when all the moisture has escaped the capacitor will really be dry and it will no longer work. Electrolytic capacitors also develop leakage. Leakage in an electrolytic capacitor can be detected quite easily; you will notice that the capacitor starts to get hot. In normal operation there is some leakage through an electrolytic capacitor and this will cause the capacitor to get warm, but if you notice that an electrolytic is getting extremely hot, it is a sign that the leakage through the capacitor is too high, and the capacitor should be replaced.

## SUMMARY

In this section of the lesson you learned that there are a number of different types of capacitors. There are two types of variable capacitors, those with an air dielectric and those with a mica dielectric such as compression-type trimmers. You also learned that there are paper, mica, ceramic, and electrolytic capacitors. You are likely to run into all types, but you will probably have more to do with electrolytics than the other types because electrolytic capacitors cause more trouble than the others.

It is not important that you remember how the various types of capacitors are made, the important thing to remember is that capacitors can open, they can short, or they can develop intermittent defects. A low resistance reading across a capacitor indicates that the capacitor is shorted or has developed excessive leakage. Exactly how low a resistance can be tolerated through the capacitor depends upon the type of capacitor and the circuit in which it is used.

# How Capacitors Work in AC Circuits

Capacitors actually have very little use in circuits where there is nothing other than pure dc. Once a capacitor is placed in a dc circuit and charged, there will be no further current flow in the circuit. The chief importance of a capacitor comes from the way in which it works in ac circuits, and in circuits where there are ac and dc mixed together. Capacitors are used in all types of ac circuits found in electronic equipment ranging from the low frequencies found in power supplies and audio equipment up to the very high frequencies found in microwave equipment. Microwave equipment is that used at frequencies of 3000 mc (megacycles) and higher. The importance of the capacitor in ac circuits depends upon its ability to store an electrical charge. Because a capacitor can store a charge, it can be used in an ac circuit. Now, let us see how this is possible.

## HOW AC FLOWS IN CIRCUITS USING CAPACITORS

In Fig. 17 a simple circuit is shown in which a capacitor is connected across an ac generator. In this type of circuit there will be a current flow. The exact amount of current flowing in the circuit will depend upon the voltage of the generator and the capacity of the capacitor.

When the terminal of the generator marked 1 is negative and the terminal marked 2 is positive, electrons will flow from terminal 1 into the side of the capacitor marked A and force electrons out of the side marked B to terminal 2 of the generator which will attract these electrons because it is positive. During the next half cycle when the polarity of the generator reverses, electrons that have been

piled up on the side of the capacitor marked A will be pulled out by terminal 1 which is positive, and electrons will be forced into side B of the capacitor by terminal 2 of the generator, which is negative. Extra electrons will be forced on this side of the capacitor so the side marked B will become negative and the side marked A will become positive.

This action continues as the generator goes through first one half cycle and then the other. Electrons will flow back and forth in the circuit. They will flow first into one side of the capacitor and force electrons out of the other side and then electrons will build up a surplus and into the side on which there was a shortage. It is important that you notice that the electrons do not flow through the capacitor. You will remember that the plates of the capacitor are separated by a dielectric and the dielectric is a non-conducting material. However, because the capacitor can store a charge, we have the effect of a current flowing in the circuit.

The action inside the capacitor can be seen in more detail in Fig. 18. At the start of the ac cycle when the voltage of the generator is zero, there will be a certain number of electrons on both plates of the capacitor. The electrons in each atom of the dielectric will be revolving around the nucleus as shown in Fig. 18A. However, when electrons begin to move into one plate as shown in Fig. 18B

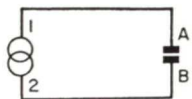

FIG. 17. A capacitor connected across a generator.

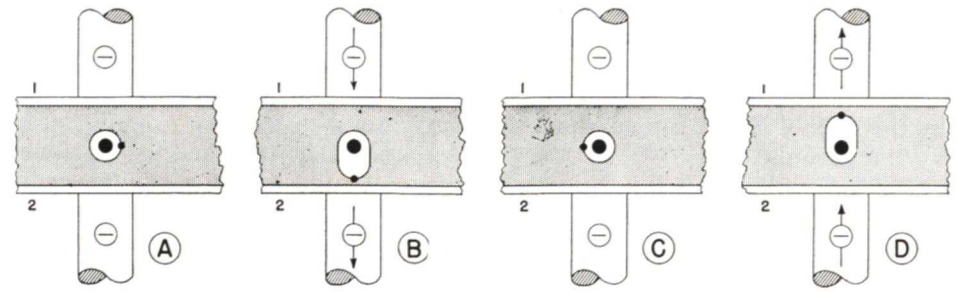

FIG. 18. When ac is applied to a capacitor, the bound electrons in the dielectric move first one way, then the other, so in effect, alternating current flows through the capacitor.

and out of the other plate, the electrons in the dielectric will be forced out of their normal path as shown. Thus, although the electron flowing into plate 1 does not reach plate 2, it does force another electron in the dielectric over near plate 2, and this in turn forces an electron out of plate 2.

As the ac voltage decreases and finally drops to zero, the electrons in the dielectric will return to the normal position as shown in Fig. 18C. During the next half cycle, when the polarity of the generator reverses, electrons will be forced into plate 2 and they in turn will force the electrons in the dielectric out of their normal positions and they will push electrons out of plate 1. Thus we have the effect of current flowing through the capacitor in the opposite direction, although the electrons flowing into the one plate never do get through the dielectric into the other plate of the capacitor.

You can see that there is a back and forth motion of the electrons in the conductors connected to the capacitor. The electrons in the dielectric will move back and forth and therefore we are justified in saying that ac current flows "through" a capacitor, even though the electrons never get through the dielectric into the other plate. Because of this effect, capacitors can be used in ac cir-

cuits. They are very useful in circuits where we have both ac and dc. The capacitor can be used to block dc, while at the same time allowing ac to flow through the capacitor.

The action of a capacitor in allowing electrons to flow back and forth is a good demonstration of what ac is. The actual movement of each electron is very small, however, there may be a large number of electrons moving back and forth over a very short distance. The distance of the electron's travel is unimportant, the important thing is the number of electrons in motion. If we have a large number of electrons in motion, we have a large current.

The capacitor does not allow electrons to move back and forth without offering opposition. Capacitors do offer opposition to the flow of ac current through them and this opposition is called capacitive reactance.

## CAPACITIVE REACTANCE

Since work must be done to move the electrons in the dielectric back and forth to permit ac current to flow, in a capacitive circuit there is opposition to the flow of current. This opposition is called capacitive reactance. This opposition is measured in ohms, just as the inductive reactance of a coil is measured in ohms.

However, there is a great deal of difference between inductive reactance and capacitive reactance.

Capacitive reactance is represented by the symbol  $X_c$ . It can be expressed by the formula:

$$X_c = \frac{1}{6.28 \times f \times C}$$

In this formula the frequency  $f$  is the frequency expressed in cycles and  $C$  is the capacity in farads. We can write this formula in another way by expressing  $C$  in microfarads. To do this, we divide 6.28 into 1 and multiply this result by 1,000,000. We get:

$$X_c = \frac{159,000}{f \times C}$$

In this expression  $f$  is the frequency in cycles per second, and  $C$  is the capacity in microfarads.

From this formula there are several important things that you can see. First of all, let us consider the effect of a change in frequency on the reactance of a capacitor. Let us find the reactance of a 1-mfd capacitor at a frequency of 10 cycles per second. Using the formula:

$$X_c = \frac{159,000}{f \times C}$$

and substituting 10 for  $f$  and 1 for  $C$  we get:

$$X_c = \frac{159,000}{10 \times 1} = 15,900 \text{ ohms}$$

When the frequency is 100 cycles, we get:

$$X_c = \frac{159,000}{100 \times 1} = 1,590 \text{ ohms.}$$

Notice that at the higher frequency, the capacitive reactance is lower.

As the frequency *increases*, the capacitive reactance *decreases*. In an inductive circuit we had just the opposite effect, if the frequency increased, the inductive reactance increased.

We have the same situation when

the capacity is increased. If the capacity is made larger, the capacitive reactance decreases. We can see this if we find the reactance of a 1-mfd capacitor at a frequency of 100 cycles per second and then find the reactance of a 10-mfd capacitor at 100 cycles per second. We already know that the 1-mfd capacitor has a reactance of 1590 ohms. To find the reactance of the 10-mfd capacitor we use:

$$X_c = \frac{159,000}{100 \times 10} = 159 \text{ ohms.}$$

Notice that this is one tenth the reactance of the 1-mfd capacitor at 100 cycles per second. Therefore in a capacitive circuit, we have exactly the opposite effect to what we had in an inductive circuit. We can say that *the capacitive reactance varies inversely with the frequency and the capacity*. This simply means that if the frequency or capacity increases, the reactance decreases, and if the frequency or capacity decreases, the capacitive reactance increases.

While we are discussing capacitive reactance it might be well to point out that the reactance of even a small capacitor becomes quite small if the frequency is made high enough. For example, a 100-mmf capacitor has a reactance of 1590 ohms at a frequency of 1 megacycle. One megacycle is not a high radio frequency; as a matter of fact this frequency falls in about the middle of the standard radio broadcast band. At a frequency of 10 megacycles, which is in the short-wave bands, the reactance is only 159 ohms, and at a frequency of 100 megacycles, which is in the FM broadcast band, the reactance is only 15.9 ohms. Even a 1-mmf capacitor has a reactance of only 1590 ohms at a frequency of 100 megacycles. Thus, if the frequency is made high enough even small capacitors have a comparatively low reactance.

**Capacitors in Parallel.** When two capacitors are connected in parallel we have two capacitive reactances in parallel. If the capacitive reactance of each capacitor is 100 ohms, we have the same effect as we would have with two 100-ohm resistors in parallel. The reactance would be only 50 ohms. This effect is the same as connecting a capacitor twice as large as either capacitor into the circuit.

To find the total *capacity* of capacitors connected in parallel you simply add the capacities. In other words, if a 4-mfd capacitor is connected in parallel with a 6-mfd capacitor, the total capacity in the circuit is 10 mfd. The reactance in the circuit would be exactly the same as you would obtain by connecting a 10-mfd capacitor in the circuit.

This is an important rule to remember—to find the total capacity of parallel-connected capacitors you simply add the capacitors together. The working voltage that can be applied to the parallel combination is the lowest working voltage of the capacitors connected in parallel.

**Capacitors Connected in Series.** When capacitors are connected in series, we have two reactances in series. The total capacitive reactance in the circuit is equal to the sum of the two reactances, just as the total resistance in a circuit made up of resistors connected in series is equal to the total resistance in the circuit. Thus connecting capacitors in series *increases* the total reactance in the circuit. If the reactance in the circuit increases, then the capacity must *decrease*.

When two capacitors are connected in series, you can find the total capacity by using the same type of formula you use to find the values of resistors connected in parallel. The total capacity of two capacitors  $C_1$  and  $C_2$

connected in series is equal to:

$$C_T = \frac{C_1 \times C_2}{C_1 + C_2}$$

When capacitors are connected in series, the total capacity is always less than the capacity of the smallest capacitor.

You will seldom actually have to calculate the value of series and parallel-connected capacitors, however, it is important for you to realize that connecting capacitors in series results in a lower total capacity, while connecting them in parallel results in a higher total capacity in the circuit.

## SUMMARY

There are several important things that you should remember from this section of the lesson. First, remember that although current does not actually flow through a capacitor, the effect produced in the circuit is the same as though current does flow through the capacitor. Thus we say that an ac current flows through a capacitor.

Remember that we call the opposition offered to current flow in an ac circuit by a capacitor the *capacitive reactance*, and the capacitive reactance is measured in ohms. The capacitive reactance is equal to:

$$X_c = \frac{159,000}{f \times C}$$

where  $f$  is in cycles per second and  $C$  is in microfarads.

Increasing the capacity or the frequency in the circuit will result in a lower capacitive reactance and decreasing the frequency or capacity will result in a higher capacitive reactance.

When capacitors are connected in parallel, the total capacity is equal to the sum of the capacities. When capacitors are connected in series, the total capacity is always less than the capacity of the smallest capacitor.

# Simple RC Circuits

An RC circuit is a circuit containing resistance and capacity. These circuits are found in all types of electronic equipment. RC circuits are used to shape signals. We can apply a signal with one type of wave shape to an RC circuit and get a signal having a different wave shape at the output. RC circuits are used to feed signals from one stage to another in electronic equipment. There are many applications of RC circuits, but before you can understand how these circuits are used, you must learn something about the fundamentals of the circuit.

You already know that when a capacitor is connected across a voltage source it does not charge instantly, but takes a certain length of time to charge. The length of time depends

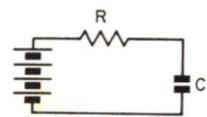

FIG. 19. A resistor and a capacitor connected in series across a battery.

upon the size of the capacitor and the resistance in the circuit. The length of time it takes to charge up to a certain value is called the *time constant*. Time constant is an important consideration in circuits using resistance and capacitance, let's learn a little more about it.

## TIME-CONSTANT

When a resistor is connected in series with a capacitor and the two are connected across a battery as shown in Fig. 19, current begins to flow in the circuit to charge the capacitor. At the first instant that the resistor and capacitor are connected across the battery, a rather large current flows

because there is no charge on the capacitor. The size of the resistor will limit the amount of current that can flow for any given voltage source. At this instant, although the current flowing in the circuit is high, the voltage across the capacitor is zero. At this instant the current flowing into the capacitor is a *maximum* but the voltage across it is *zero*.

Gradually the capacitor is charged and as the capacitor charges, the voltage across the capacitor builds up and the current flowing in the circuit decreases. This is due to the fact that the actual voltage driving electrons in the circuit is equal to the source voltage minus the voltage across the capacitor. As the voltage across the capacitor increases, the voltage forcing electrons through the circuit goes down. In other words the current flowing into the capacitor decreases as its voltage increases.

If we draw a graph showing the way in which a capacitor charges, it would look like Fig. 20. In this graph, time is measured along the horizontal axis. The extreme left of this axis represents the instant we connect the capacitor and resistor across the source. Notice that at this instant there is no voltage across the capacitor, but the

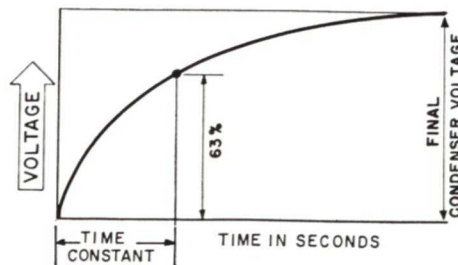

FIG. 20. How a capacitor charges. The time-constant is the time it takes for the capacitor to charge to 63% of the total voltage.

voltage starts to build up rapidly. Then, as the charge on the capacitor increases, the rate of charge decreases so that when the capacitor is almost charged to a value equal to the source voltage, the rate of charge becomes very slow.

When we speak of the time-constant of an RC circuit, we mean the time it takes the capacitor to charge up to about 63% of the total source voltage. This value is shown on Fig. 20. The time-constant of any RC circuit in seconds can be found by multiplying the resistance of the resistor in megohms times the capacity of the capacitor in mfd. Thus, if a 2-mfd capacitor is connected in series with a 1-megohm resistor, the time-constant will be  $2 \times 1 = 2$  seconds. This means that it will take two seconds for the capacitor to charge up to 63% of the source voltage.

One important thing to note is that the source voltage has nothing to do with the time-constant of the circuit. In other words, whether a resistor-capacitor combination is connected across a 10-volt battery or a 100-volt battery, the time-constant is the same. If a certain resistor and capacitor are connected across a 10-volt battery and the time-constant is one second, the capacitor will charge up to 63% of 10 volts, or 6.3 volts in one second. On the other hand, if the same resistor-capacitor combination is connected across a 100-volt battery, the capacitor will charge up to 63% of 100 volts, or 63 volts, in one second. The voltage across which the resistor-capacitor combination is connected does not determine the time-constant, the only factors that affect the time-constant are the resistor and capacitor values.

If a .05-mfd capacitor is connected in series with a 100,000-ohm resistor, the time-constant will be  $.05 \times .1$  (100,000 ohms = .1 meg) = .005 sec-

ond. Thus, you can see that the time-constant of the combination using a smaller capacitor and resistor is much shorter than the time-constant of the combination of the two-mfd capacitor and the one-megohm resistor. Decreasing the size of either the resistor or the capacitor decreases the time-constant of the circuit, and increasing the size of either the resistor or the capacitor increases the time-constant of the circuit.

## VOLTAGE-CURRENT PHASE

In the preceding example, you will notice that when the capacitor and resistor combination is first connected across the battery, a very high current flows in the circuit. However, at this first instant when they are connected across the battery, there is no voltage across the capacitor. Here we have a situation where the current is at a maximum, and the voltage across the capacitor is at a minimum or zero voltage.

As the voltage across the capacitor builds up, the current flowing in the circuit decreases until finally when the capacitor is fully charged to a value equal to the battery voltage, the current drops to zero, because the source voltage is unable to force any additional electrons onto the one plate of the capacitor or pull electrons off the other plate.

Essentially the same situation exists when a capacitor is used in an ac circuit. When the ac voltage across the capacitor builds up, the current decreases until, by the time the capacitor is fully charged, the current has dropped to zero. When the voltage across the capacitor begins to decrease, then current must flow in the opposite direction in order for the electrons to remove the excess electrons from the plate of the capacitor having a surplus of electrons and to replace the

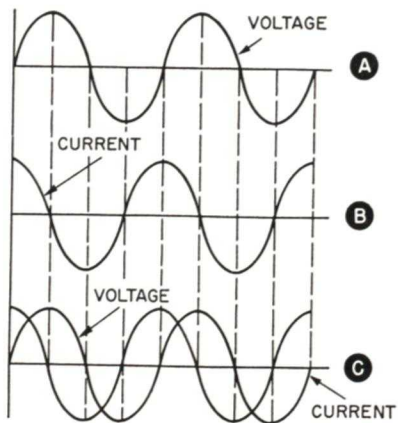

FIG. 21. The phase relationship between current and voltage in a capacitive circuit.

missing electrons on the plate of the capacitor having a shortage of electrons. During the second half of an ac cycle, as the capacitor voltage drops from a maximum value to zero, the discharge current flowing in the circuit increases until at the time the voltage reaches zero and begins to change polarity, the current flowing in the circuit is a maximum. As the voltage across the capacitor builds up in the opposite direction, the current begins to decrease until, at the instant when the capacitor is fully charged with the opposite polarity, the current flowing in the circuit has dropped to zero again.

In Fig. 21 the relationship between the current and voltage in a capacitive ac circuit is shown. Notice that in Fig. 21A two cycles of an ac sine wave are drawn. Immediately beneath the voltage sine wave, in Fig. 21B, the current that will flow at the corresponding instant is shown. The voltage and current waves are superimposed in Fig. 21C.

In this circuit the effect is exactly opposite to that obtained when a coil is used. You will remember that in inductive circuits the current lags behind the voltage. Here, in a capacitive circuit, the current is leading the

voltage. In a circuit containing only capacity, the current will lead the voltage by 90 degrees. In a circuit containing both resistance and capacity, the current will lead the voltage by a value somewhat less than 90 degrees, the actual phase difference between the voltage and current will depend upon the size of the capacitor and resistor in the circuit.

Thus, you have now seen two important examples of phase. In an inductive circuit, the current lags the voltage by 90 degrees. In a capacitive circuit, the current leads the voltage by 90 degrees.

### VOLTAGE DISTRIBUTION

If we connect a capacitor in series with a resistor and connect the two across a dc voltage source, we will eventually have the situation shown in Fig. 22A. Here, all the voltage appears across the capacitor and there is no voltage across the resistor. Since there is no voltage across the resistor, we know immediately that there is no current flowing in the circuit. Of

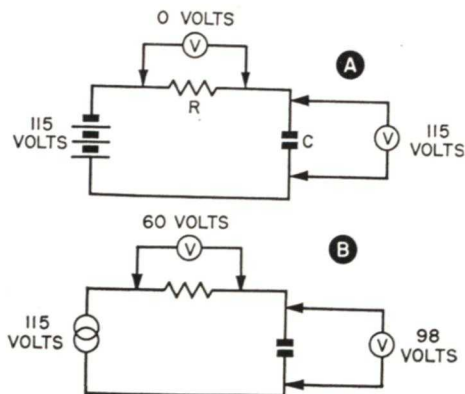

FIG. 22. When a resistor and a capacitor are connected in series across a dc source as at A, there is no current flow in the circuit. When the resistor and capacitor are connected in series across an ac generator as at B, there is current flowing, and hence there are voltage drops across R and C.

course, you know that at the instant the resistor and capacitor in series are connected across the voltage source, there will be a current flow while the capacitor is charging. However, once the capacitor is charged, there is no further current flow in the circuit and the meters would read like those shown in Fig. 22A.

If the same resistor and capacitor are connected across a 115-volt ac source and the meters are replaced by ac voltmeters, we might encounter the situation shown in Fig. 22B. Here we have 98 volts across the capacitor and 60 volts across the resistor. 98 plus 60 adds up to 158 volts, which is more than the source voltage. It is obvious that we cannot add these two voltages in order to get the source voltage, because we know that the sum of the voltage drops in a circuit must be equal to the source voltage. The reason for the apparent contradiction is that the voltmeters indicate the RMS or effective voltage appearing across the capacitor and across the resistor. These voltages are not in phase and hence cannot be added by simple addition. You will remember that we encountered exactly the same thing when a resistor was connected in series with a coil. We found that we could not simply add the voltages appearing across the two and get the source voltage but instead had to add the two by means of vectors. Let us see how we can do the same thing with these two voltages.

First, we start by drawing the current vector as shown in Fig. 23A. This vector is always drawn in this position since we use this as a starting point. We consider this vector as rotating in a counter-clockwise direction around its starting point as the current goes through its cycle. If we use a scale of 50 volts to an inch, we can draw the vector ER, representing the voltage across the resistor, 1 1/2

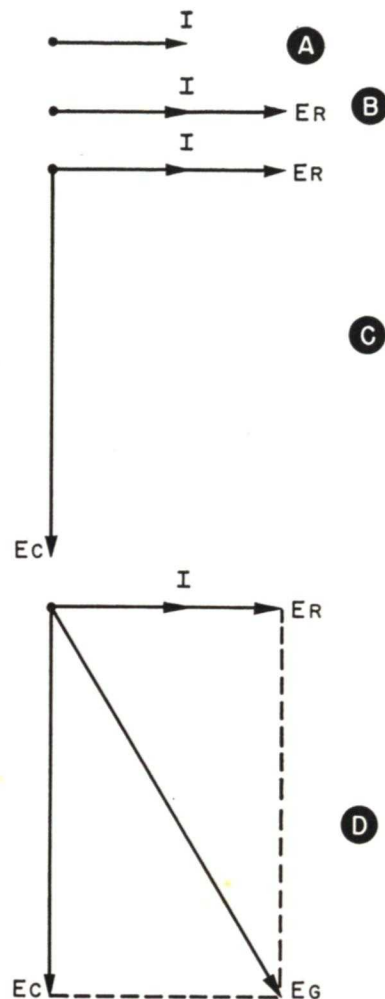

FIG. 23. Vector addition of two voltages.

inches long as shown in Fig. 23B. We know that this vector must be drawn right on top of the current vector because the voltage across the resistor is in phase with the current flowing through it.

The next vector to draw is the vector representing the voltage appearing across the capacitor. We know that in a capacitor, the current leads the voltage by 90 degrees. Another way of saying this is that the voltage lags the current by 90 degrees. Since the current vector is rotating in a counter-

clockwise direction, to show the voltage vector 90 degrees behind the current vector, we draw it as shown in Fig. 23C. Since the voltage across the capacitor is almost 100 volts, we can draw this vector 2 inches long as shown. Now we have only to draw in the dotted lines as shown in Fig. 23D and complete the vector diagram by drawing in the vector  $E_T$  which is the vector sum of the two voltages. If you measure this vector, you will find that it is a little more than  $2\frac{1}{2}$  inches long, indicating a voltage of about 115 volts. In other words, when we used this scheme of adding the two voltages, we found that the voltage across the capacitor plus the voltage across the resistor when added by means of vectors are equal to the source voltage.

Another method of arriving at the same result is by means of the formula:

$$E_T = \sqrt{E_R^2 + E_C^2}$$

To solve this we take  $E_R^2$ , which is  $60 \times 60 = 3600$ , and add this to  $E_C^2$  which is  $98 \times 98 = 9604$ . The sum is 13,204.  $E_T = \sqrt{13,204}$ , and the square root of 13,204 is approximately 115. Therefore the sum of the two voltages is 115 volts. As we pointed out before, if you know how to handle squares and square roots, the mathematical solution is somewhat quicker, but if you do not know how to do square root, then the vector solution is entirely satisfactory.

## IMPEDANCE

Because the voltage that will appear across each component in an RC circuit will depend upon the resistance or reactance of the particular part, we can draw impedance diagrams to obtain the total impedance in the circuit using the same procedure we used to add the voltage in a circuit. As an example, suppose we have a 1000-ohm

resistor connected in series with a capacitor having a reactance of 1000 ohms. If we want to find the total impedance in the circuit, we proceed as follows:

First, draw the current vector as shown in Fig. 24A. Since the voltage appearing across the resistor will be in phase with the current flowing, we draw a resistance voltage vector immediately on top of the current vector. The voltage across the resistor will depend on its resistance. If we use a scale of 1000 ohms equals 1 inch, the resistance vector  $R$  is drawn, as shown in Fig. 24B, 1 inch long.

Next, draw the vector shown in Fig. 24C to represent  $X_C$ . This vector also should be 1 inch long. It is drawn as shown, because the voltage appearing across the capacitive reactance will lag the current flowing in the circuit by 90 degrees.

We now complete the impedance

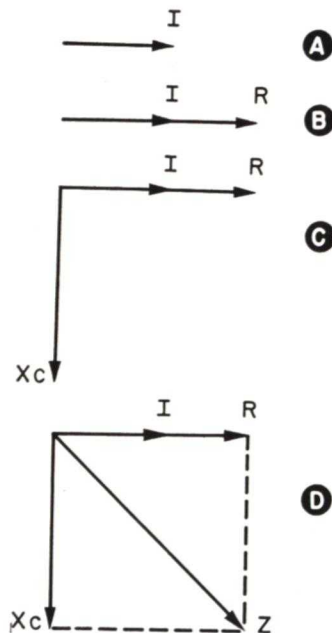

FIG. 24. Vector addition of resistance and capacitive reactance to find impedance.

diagram as shown in Fig. 24D, and you will find that the impedance vector  $Z$  will be 1.41 inches long. Since the scale we used was 1000 ohms per inch, the impedance of the circuit is 1410 ohms.

The same result could have been obtained mathematically by squaring the resistance and the capacitive reactance and adding the two together and taking the square root of the sum as indicated in the formula:

$$Z = \sqrt{R^2 + X_C^2}$$

It is important to notice the difference between the capacitive reactance and the inductive reactance. Notice that one is simply the opposite of the other. Notice that the impedance

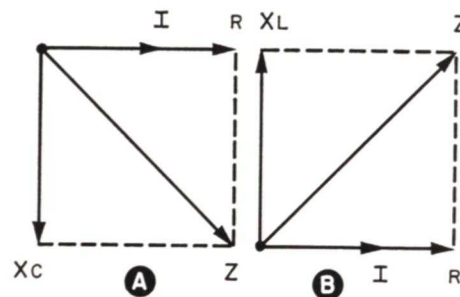

FIG. 25. When resistance and capacitive reactance are added as at A, the impedance vector lags the current; but when resistance and inductive reactance are added as at B, the impedance vector leads the current.

diagrams are drawn differently. In Fig. 25A, we see the solution of a circuit using a scale of 1000 ohms per inch where a 1000-ohm resistor is connected in series with the capacitor having a reactance of 1000 ohms. In Fig. 25B we see an impedance diagram using the same scale, where a 1000-ohm resistor is connected in series with a coil having a reactance of 1000 ohms. Notice that we end up with the same impedance, 1410 ohms,

in each case, but also notice the fact that in one case, the impedance vector leads the current vector, whereas in the other case, the impedance vector lags the current vector. In a later lesson, you will see more about these circuits and will also see the effect of having capacitive reactance and inductive reactance in the same circuit.

## SUMMARY

In this section of the lesson you began the study of a very important phase of your course; you began to see what happens when resistance and capacitance are used together in the same circuit. You found that it takes a certain length of time for a capacitor to charge when the two are used in a dc circuit, and the length of time depends upon the size of the capacitor and the resistance in the circuit. The time-constant of a circuit is equal to the product of the resistance in megohms times the capacity of the capacitor in microfarads. The time-constant of the circuit is the length of time it would take to charge the capacitor to a value of 63% of the total voltage applied to the circuit.

You learned that in an ac circuit, the current flowing in a capacitive circuit will lead the voltage by 90 degrees. In other words, a capacitive circuit acts exactly the opposite to an inductive circuit.

In an ac series circuit with a resistor and capacitor in series the voltage appearing across the resistance is not in phase with the voltage across the capacitor. If we have to add these voltages together, we must add them by means of vectors.

You also have learned that the impedance in an ac circuit using a resistor and a capacitor is the total opposition to current flow. The impedance can be obtained by means of the vector addition of the resistance

plus the capacitive reactance in the circuit.

### LOOKING AHEAD

Up to this point in your course, you have been studying the basic action of a few important components found in electronic circuits. Other than tubes and transistors, the parts you will run into most frequently are resistors, coils, and capacitors or parts

made of these three basic components. Now that you have studied each of these three parts separately, you are in a position to go ahead to see how they work together. A later lesson will discuss resonance. Resonance is perhaps one of the most important things you will study because if it were not for resonant circuits, many of the electronic miracles that we have today would not be possible.

# Lesson Questions

Be sure to number your Answer Sheet 7B.

Place your Student Number on every Answer Sheet.

Most students want to know their grade as soon as possible, so they mail their set of answers immediately. Others, knowing they will finish the next lesson within a few days, send in two sets of answers at a time. Either practice is acceptable to us. However, don't hold your answers too long; you may lose them. Don't hold answers to send in more than two sets at a time, or you may run out of lessons before new ones can reach you.

1. Name *three* types of solid dielectric capacitors. *paper mica, ceramic*
2. Express .0001 mfd (microfarads) in mmf (micro-microfarads). *100. mmf*
3. Can you use a .01-mfd, 600-volt capacitor in place of a .01-mfd, 400-volt capacitor? *yes*
4. What will happen to an electrolytic capacitor if you install it in a circuit with the wrong polarity? *do damage*
5. What is the capacitive reactance of a 10-mfd capacitor at a frequency of 10 cycles? *1590 Ω*
6. What is the total capacity of a 6-mfd capacitor and an 8-mfd capacitor connected in parallel? *14 mfd*
7. What is the total capacity of two 8-mfd capacitors connected in series? *4 mfd*
8. What do we mean by the *time-constant* of an RC circuit?
9. What is the phase relationship between the voltage across a capacitor and the current flowing through the capacitor in an ac circuit?
10. If the voltage across R is 3 volts and the voltage across C is 4 volts, what is the generator voltage in the circuit shown?

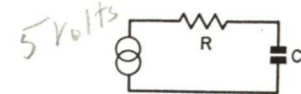





## SUCCESS AND HAPPINESS

I would like to have you feel, as you read these short personal messages, that you are seated right alongside my desk. Years of experience with thousands of ambitious men proved to me that a word of advice or cheer can go a long way toward speeding your progress. As I see it, my responsibility goes farther than just giving you the *very best* training—my duty is to help you get the very most out of *life*—to attain *real happiness*.

You, in common with all other NRI men, desire success. You think that success will bring happiness, but this is not necessarily true. I believe that a man must train himself for happiness, just as he must train himself for success.

The first thing you must understand is this: *Happiness comes from within!* There is no guarantee that material things—money, success, friends and possessions—will make you happy, for happiness is a state of mind. You must learn to be happy within yourself.

In these one-minute chats, then, I am going to teach you how to get the most happiness out of the success which is in store for you.

*J. E. Smith*