

**FREQUENCY MULTIPLIER,
BUFFER, AND OUTPUT STAGES**

finished

Nov. 27, 1958

19RC

NATIONAL RADIO INSTITUTE

ESTABLISHED 1914

WASHINGTON, D. C.

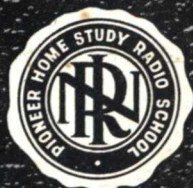

STUDY SCHEDULE NO. 19

For each study step, read the assigned pages first at your usual speed. Reread slowly one or more times. Finish with one quick reading to fix the important facts firmly in your mind, then answer the Lesson Questions for that step. Study each other step in this same way.

- 1. Cascade R.F. Amplifiers Pages 1-3
The standard amplitude-modulated transmitter uses a chain of cascade amplifiers to raise the output of a master oscillator to the level required to drive an output stage that is capable of delivering the rated power of the transmitter. Here you also learn about low-level and high-level modulation.
- 2. The Buffer Amplifier Pages 4-9
The buffer serves the important function of preventing changes, introduced by the process of modulation, from affecting the master oscillator. Answer Lesson Questions 1 and 2.
- 3. Frequency Multipliers Pages 9-21
Frequency multipliers enable a standard crystal to be used in the master oscillator of an ultra-high-frequency transmitter. Doublers and triplers are sometimes used in combination to give multiple increases in frequency. Answer Lesson Questions 3, 4, and 5.
- 4. Basic Output Stages Pages 21-27
The output stage is a high-power class C amplifier when high-level modulation is used. The only other output stage commonly used is the class B linear type that is used with low-level modulation. The latter is to be studied later, so this section deals with the characteristics of the class C stage. Answer Lesson Questions 6 and 7.
- 5. Practical Facts about Output Stages Pages 28-36
Here you learn practical facts about class C output stages—how to suppress harmonics; how to suppress parasitic oscillations; how to neutralize; how to align. Answer Lesson Questions 8, 9, and 10.
- 6. Start Studying the Next Lesson.

FREQUENCY MULTIPLIER, BUFFER, AND OUTPUT STAGES

Cascade R.F. Amplifiers

TRANSMITTERS are capable of delivering high power output at a controlled frequency because it is possible to amplify the relatively low power output of a master oscillator, by using cascade amplifiers, to such a level that it can drive an output stage that is designed to deliver the rated transmitter power.

It is not impossible to design a very high-powered oscillator. However, you will recall from your study of oscillators that such an oscillator will not maintain its frequency reasonably constant. For this reason, high-power oscillators are seldom used. Instead, a master oscillator is designed to have the best possible frequency stability, then a series of amplifying stages is used to get the required power. With this arrangement, it is possible to draw very little power from the oscillator, thus insuring its frequency stability.

However, radio waves in space have no value unless they carry some form of intelligence. Somewhere along the line of amplifiers, therefore, modulation must be impressed upon the r.f. signal. This modulation can be in any form that is desired—it can correspond to telegraph signals, voice, music, impulses from a television or facsimile scanner, etc.

There is more than one way of modulating the r.f. signal. We can vary the amplitude of the r.f. signal with the

intelligence signals—this is called amplitude modulation. Or, we can vary the frequency of the r.f. signal—this is called frequency modulation. A third possible method, not much used by itself, is to vary the phase relationship between succeeding r.f. cycles—this is called phase modulation. You will study frequency modulation (and such phase modulation as is used) in much more detail in later Lessons, so for now, let's just consider amplitude modulation briefly. (This too will be covered more fully later.)

AMPLITUDE MODULATION

There are two levels at which amplitude modulation may be introduced into a transmitter. Both of these are shown in block diagram form in Figs. 1A and 1B.

► In Fig. 1A we have what is called "high-level" modulation. In this arrangement, as shown by the wave forms above the separate stages, the low-power signal from the oscillator is amplified by several r.f. amplifiers in cascade until sufficient power is developed to drive the final power output stage. Modulation is not introduced until the high-power output stage is reached—hence the name of the system. The high-power audio modulator must be capable of supplying audio power equal to one-half the output power of the final output stage.

► An alternative transmitter arrangement sometimes used is shown in Fig. 1B. In this "low-level" modulation system the oscillator output is amplified as before by cascade r.f. amplifiers. Modulation, however, is accomplished in a relatively low-level stage where the modulator need not supply large amounts of audio power. The

These will be discussed in detail in a later Lesson.

INTERMEDIATE POWER STAGES

The cascade r.f. amplifier is designed so that, fundamentally, the stages are of such power that each builds up the power in reasonable steps until enough is developed to "drive" the output

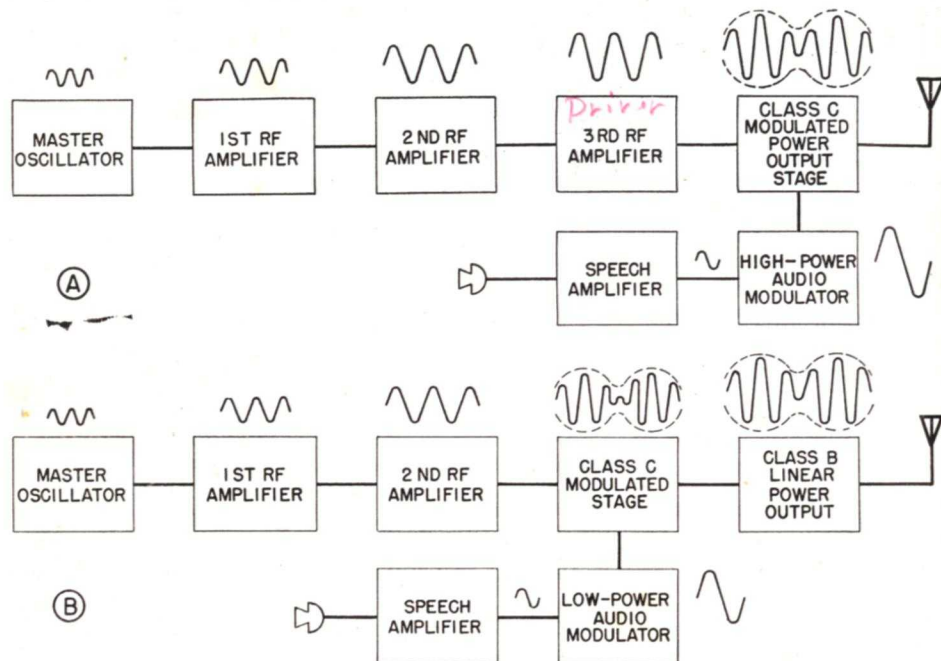

FIG. 1. In the high-level system at A, the high-power modulator modulates the final output stage. All r.f. amplifiers have constant excitation. In the low-level system at B, modulation is accomplished in a low-power stage. The high-power output stage, therefore, has varying excitation and must be operated as a class B linear amplifier.

output of the modulated amplifier then is applied to a high-power stage before being fed to the antenna. Since this last power stage has an excitation power which is *varying* in amplitude in accordance with the modulation peaks and troughs, it must be operated in class B so that variations in excitation will be faithfully reproduced by corresponding changes in output power. Such power stages are commonly called "Class B Linear Amplifiers."

stage. However, there are transmitters, particularly those in the broadcast service, that apparently "waste power" somewhat. In most cases like this, you will find that the manufacturer has designed a "package" transmitter. That is, the basic design is of a low-power transmitter that meets standard specifications, at, for example, 250 watts output to the antenna. Then, the required "unit" amplifier and modulator may be add-

ed, and the same basic "driver" used for higher outputs. Thus, a 250-watt unit may be made to drive a 1000-watt stage, which is another popular size of transmitter, even though this stage could be driven by, say, 150 watts.

Similarly, the two-unit, 1000-watt set-up may in turn drive a 5000- or 10,000-watt final stage. In each case, an appropriate modulator is added, where high-level modulation is used, as in Fig. 1A.

The low-level type of Fig. 1B may result from this design practice. That is, the manufacturer might design a 10,000-watt high-level transmitter as in Fig. 1A, then may supply a linear class B output unit to increase the output to 50,000 watts. Using the same modulator, this becomes a low-level modulated transmitter in the higher power; without the class B stage it is a lower power, high-level transmitter.

Buffer Action. The fact that transmitters are modulated, places another burden on the intermediate power-amplifier stages. The process of modulation causes the current in the modulated stage to vary widely and sharply. If there is enough interaction between the circuits, the loading of the modulated stage on the previous amplifier will vary, and in turn this may be transferred back to the master oscillator as a load variation.

Similarly, if a common power supply is used for all of the stages, it is possible for variations in the modulated stage to affect the supply voltages on the other stages.

Fortunately, however, this effect is not serious if a sufficient number of stages is employed. Once again, we have a reason for using a number of

tubes in a cascade arrangement. It might be possible for one amplifier to amplify the output of the master oscillator sufficiently to drive an output stage if there were no modulation. However, with modulation, we find it necessary to use a series of stages, in most instances, to prevent reaction on the oscillator from the modulator.

Because of the effect of the stage in reducing load variations, the first r.f. amplifier is almost always called the "buffer." Sometimes this term is applied to all the intermediate r.f. amplifiers. (However, the stage just before the output, the third r.f. stage in Fig. 1A, is frequently labeled "driver stage" because it "drives" the output stage.)

Frequency Multiplication. There is a third function which the intermediate r.f. amplifier is sometimes required to perform. This is one of frequency multiplication. It may happen that crystals cannot produce a frequency as high as the required output frequency. If so, it is possible to design one of the intermediate amplifiers so that it has a strong harmonic output. The second or third harmonic of the crystal frequency may then be taken from this amplifier and amplified by the succeeding intermediate amplifier stages. This lets us get an output frequency that may be two or three times the master oscillator frequency. By using a chain of multipliers in this manner, we can get frequencies of four, six, or any other multiple of the master oscillator output. However, as you will learn later in this Lesson, it is rather rare to multiply more than two or three times with amplitude modulation.

The Buffer Amplifier

The first r.f. amplifier (buffer) is particularly designed to serve one definite, basic purpose—and that is to reduce the loading of the oscillator as much as possible in order to give a high degree of frequency stability, and to isolate the oscillator from any changes in loading which might serve to vary the fundamental operating frequency.

Buffer amplifiers provide these benefits in two different ways:

1. Since the buffer amplifier directly following the master oscillator is itself a relatively low-power stage, the driving power drawn from the oscillator is very small; consequently, the loading of the oscillator is kept at a minimum, and the highest possible frequency stability is obtained.

2. Since an amplifier stage provides amplification in one direction only—that is, from grid to plate and not the reverse—any changes in buffer loading

conditions, such as those resulting when the plate voltage of the buffer is varied, are prevented to a great extent from reaching the master oscillator where they might bring about an undesirable frequency shift.

From these characteristics, it is obvious that this amplifier is quite aptly named, for it does provide a "buffer" action between the frequency-determining master oscillator and the following higher-powered circuits.

INPUT IMPEDANCE OF A BUFFER AMPLIFIER

We find, however, that the buffer or isolating performance of a buffer amplifier is not perfect. This can be visualized more clearly if we examine the typical master-oscillator-buffer-amplifier circuit shown in Fig. 2.

In this arrangement we have the triode crystal oscillator VT_1 impedance-coupled through coupling ca-

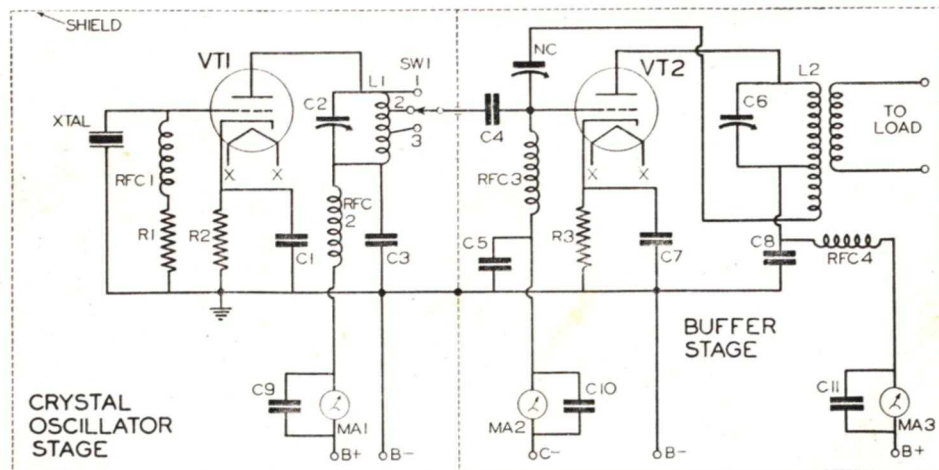

FIG. 2. A typical triode buffer amplifier following a crystal master oscillator. The buffer not only increases available power but isolates the oscillator from any changing load.

capacity C_4 to the grid of the triode buffer tube VT_2 . In typical class C operation, the grid bias supplied to VT_2 is approximately twice cut-off value so that plate current is allowed to flow for less than one half-cycle. To prevent spurious oscillation, the triode buffer must be neutralized; and in the figure, plate neutralization is incorporated by the tap on the output tank coil L_2 and the neutralizing con-

current flows on each of the peaks.

Keying the Plate Circuit. Suppose we first assume that the telegraph key is inserted in series with the buffer high-voltage plate supply between the milliammeter MA_3 and the r.f. choke RFC_4 in Fig. 2. In this case, as illustrated in Fig. 3A, with the key open the plate current through MA_3 will be zero; and when the key is closed, plate current rises abruptly to full operating

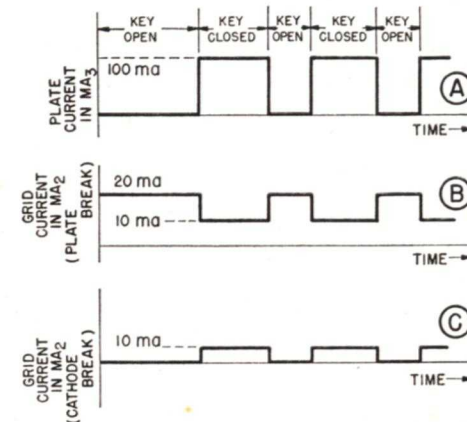

FIG. 3. If the plate current of the buffer amplifier in Fig. 2 were changed by keying, similar but much smaller changes would occur in the grid current. Loading of the oscillator, therefore, would not be constant.

denser NC. By inductive coupling to the buffer tank L_2-C_6 , output power is supplied to the load which usually is the grid circuit of a following amplifier.

Now, what would happen to the loading on the oscillator VT_1 if we should attempt to modulate this first buffer stage VT_2 ? For simplicity, let's investigate what happens to the buffer grid circuit when the plate current flow is broken as it would be for radiotelegraph signaling. Furthermore, let's assume that the buffer is a class C stage. The excitation will drive the grid positive on the peaks so that grid

value, say 100 ma in this example.

Under these circumstances, however, the buffer grid current flowing through milliammeter MA_2 in Fig. 2 also goes through abrupt changes. With the key open, there is no plate voltage, and hence no plate current flows. Now, when the oscillator signal makes the grid positive, the current flowing to the grid will be high, and may be, for example, approximately 20 ma. as in Fig. 3B.

When the key is closed, plate current, of course, starts flowing. When this occurs, the plate voltage accel-

erates the electrons so that most go past the grid. The average grid current then drops quickly to the normal operating value of say, 10 ma.

Keying the Cathode. Instead of breaking the plate lead, we might key the cathode circuit of the buffer amplifier in Fig. 2. Nevertheless similar changes would still occur in the grid current.

As an example, suppose we insert the telegraph key between the cathode resistor R_3 and ground. As before, as shown in Fig. 3A, with the key open, the plate current will be zero, and rise abruptly to 100 ma. when the key is closed.

Cathode keying, however, breaks the grid as well as the plate circuit. With the key open, then, we find the grid current as well as the plate current is zero. This is illustrated by Fig. 3C. For a closed key, of course, grid current rises immediately to the normal operating value of approximately 10 ma.

Grid-Impedance Changes. Figs. 3B and 3C show that the impedance of the grid changes sharply with keying no matter what form is used. Thus, for plate keying as in Fig. 3B, the grid current goes down when the key is closed. This means the grid impedance goes up.

On the other hand, for cathode keying, when the key is closed the grid current rises from zero up to the normal operating point. This indicates, of course, that the grid impedance goes down.

This brings out the fact that *in any r.f. amplifier that draws grid current, changes occurring in plate-circuit conditions will be accompanied by similar changes in grid input im-*

pedance. This is an important fact.

► Referring to Fig. 2, it now becomes apparent that if we should key the buffer stage VT_2 , its grid impedance would be changed and the load presented to the master oscillator VT_1 would not be constant. The same would hold true if we were to plate-modulate the buffer by means of audio-frequency modulator equipment which raised and lowered the buffer plate voltage. And as we discovered in a preceding Lesson, this variation of oscillator loading can cause a frequency shift.

From this, you can see why the buffer stage is NOT modulated in any transmitter that must maintain a constant output frequency. However, variations in the supply voltage, or load variations from the following stage may produce some change in the buffer circuit loading. Where even this may be intolerable, the buffer stage may be designed as a class A stage. For this operation, the grid signal is kept at a level that never drives the grid positive; hence, no grid current will flow, regardless of the plate potential changes. The grid then offers a constant (and very high) input impedance. True, the power output of this class A stage is far less than that of a similar class C stage, but the vastly improved buffer action may be more important. You will particularly find this design in high-quality broadcast transmitters.

CLASS C BUFFERS

Where the load and supply changes are not unreasonable, and particularly where higher efficiency is necessary, class C operation of the buffer may be

permissible. (It still is not directly modulated, however.) It is important to remember that, even at the worst, the impedance variations in the buffer grid circuit are very much smaller than those occurring in the buffer plate. Thus, inspecting Fig. 3 again, we see that the plate current undergoes a change of 100 ma.; nevertheless, current changes for the buffer grid are approximately 10 ma., or only about one-tenth as much. If current changes flowing in the grid are reduced ten-to-one below those of the plate, then the impedance variations of the grid circuit, when compared to those of the plate, also are reduced by about the same figure. Even a class C buffer amplifier, therefore, does possess a substantial buffer action.

In actual transmitter circuits, the degree of buffer action from a class C buffer stage is just about equal to the power gain of the stage. Hence, if a given buffer amplifier furnishes a grid-to-load power gain of 5-to-1, plate impedance variations reaching the grid will be reduced approximately 5 times. And similarly, a buffer having a power gain of 15-to-1 might be expected to have grid-impedance variations which are only 1/15 of those in the plate or load circuits during modulation. These figures, of course, are only approximations and should not be considered as accurate. They do serve to show, however, the magnitude of buffer action commonly obtained in practical applications.

In certain types of transmitters such as portable or emergency equipment in which the frequency drift limitations are not too severe, the buffer action afforded by a single class C buffer stage may be adequate enough for

practical use, and the following stage may be modulated.

► This problem is not so severe where several intermediate stages are in cascade, because they all add to the buffer action. If we assume that each of the cascade amplifiers gives a power gain of 10, then the impedance variations in the modulated output stage will be reduced 10 times at the input of the third stage in Fig. 1A. The second stage in turn will reduce these variations 10 times more, thereby reducing load changes 100-to-1. Finally, the buffer reduces impedance variations by another factor of 10 to give an over-all reduction of 1000-to-1. In this manner, severe load fluctuations brought about by modulation of the output stage are reduced to an almost negligible figure by the time they reach the master oscillator. (This is why some call all intermediate stages "buffers.")

Separate Power Supplies. Although they are not indicated in the block diagram of Fig. 1A, the power supplies feeding the separate stages must be considered carefully.

If one were to attempt to operate all the stages from a single power supply, serious coupling between the modulated output stage, the buffer amplifiers, and the master oscillator might result. This is true because the high-power stage in drawing heavy current pulses on modulation peaks will drop the supply voltage slightly. If the same supply is used for the oscillator, then it is obvious that these voltage fluctuations may adversely affect the oscillator stability.

To offset this possibility, almost invariably a separate, low-power B supply is used for the master oscillator alone. In this way, a constant oscil-

lator plate voltage is insured, and the chances of a frequency shift brought about by voltage variations are eliminated.

As an additional precaution, the buffer amplifier and the intermediate power stages are usually operated from a supply different from that of the high-power output stage. When this is done, plate-voltage variations in the output stage are confined to the power

particular arrangement, impedance coupling is used between the oscillator tank and the buffer grid. Other types of coupling, however, such as inductive coupling, link coupling, etc., may be used if desired.

The buffer in Fig. 2 uses a triode tube, and as we discovered in earlier Lessons, it is necessary to neutralize this type of r.f. amplifier to prevent self-oscillation. Indeed, if the buffer

Use of Screen-Grid Tubes. To eliminate neutralization troubles it is becoming more and more standard practice to use screen grid, pentode, or beam tubes in buffer amplifiers. Such tubes, of course, do not require neutralizing at any except the highest frequencies. Since buffer amplifiers are never modulated, the added electrode does not introduce additional difficulties. Indeed, the freedom from neu-

tralization requirements makes the design of buffers for "all-band" transmitters comparatively simple.

A typical screen-grid buffer amplifier following the crystal master oscillator is illustrated in Fig. 4. This circuit indicates inductive coupling for both input and output of the buffer stage. Just as with a triode buffer, however, other coupling methods may be used.

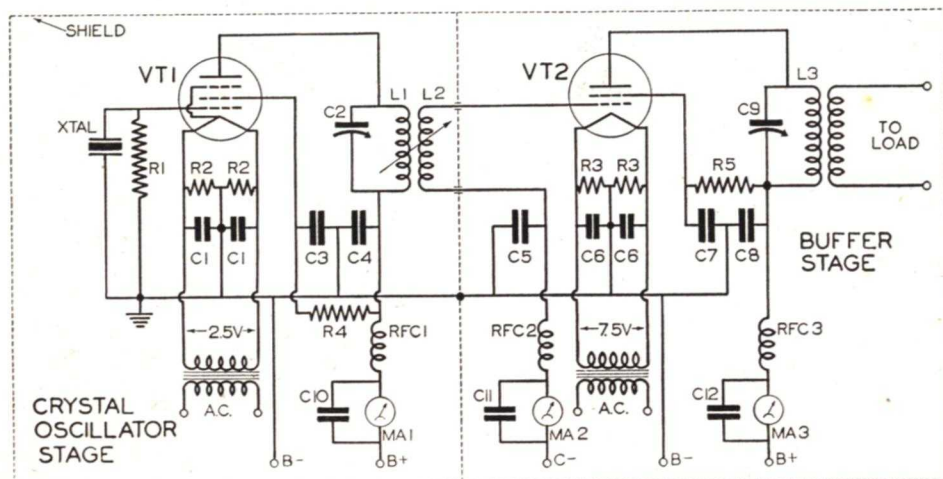

FIG. 4. A typical buffer stage using a screen grid tube. Screen grid tubes are desirable because they require no neutralizing.

supply for that stage alone, and there is no possibility of their being fed to the buffer stages where they could decrease the effective buffer action.

This arrangement, of course, makes three power supplies necessary: a low-power supply for the master oscillator, a medium-power supply for the intermediate stages, and a high-power supply for the output stage.

TYPICAL BUFFER CIRCUITS

As mentioned before, Fig. 2 shows the manner in which a typical buffer amplifier is used to amplify the output of a crystal master oscillator. In this

in the figure were not properly neutralized and it suddenly burst into oscillation, the spurious energy fed back into the master oscillator circuit might be sufficient to shatter the quartz crystal. Aside from this, the danger of "off-frequency" operation and the low efficiency accompanying self-oscillation make it imperative that triode buffers be neutralized.

Neutralization at best, however, is a nuisance, particularly so in installations using wave-band switching wherein the entire tank coil or portions of it may be switched in and out of the buffer circuit.

Frequency Multipliers

In a preceding Lesson we discovered the most practical form of oscillator which possessed a high degree of frequency stability is one in which the frequency is determined by mechanical oscillation of a piezoelectric quartz crystal. Because of such desirable characteristics, almost all modern transmitters use some form of crystal-controlled master oscillator.

The natural mechanical resonance of a crystal, of course, is determined primarily by its thickness, and crystals are ground very carefully to a definite thickness to make them oscillate at some specific frequency. Unfortunately, as the thickness of a crystal is decreased in order to reach higher and higher frequencies, the plate becomes so thin that it is easily broken. Indeed, it becomes so fragile it can be used only in special circuits at greatly reduced power.

In practical instances, crystals are seldom used above a fundamental frequency of about 10,000 kc., that is, 10 mc. For crystal-controlling the output of an ultra-high-frequency transmitter, therefore, some indirect means of using a crystal master oscillator must

be employed. This is usually accomplished by operating the crystal oscillator at some *sub-harmonic* frequency, say, $\frac{1}{2}$, $\frac{1}{3}$, $\frac{1}{16}$, etc., of the desired output frequency and then employing one or more frequency multipliers to increase the crystal-controlled frequency to the desired point.

But what is a frequency multiplier? Basically, a *frequency multiplier* is an amplifier in which the output tank circuit is tuned to some harmonic instead of the true input frequency. Thus, if in the buffer circuit of Fig. 4, the output tank L_3-C_9 should be tuned to a frequency *twice* that of the crystal oscillator, the amplifier would not only continue to act as a buffer but also as a frequency *doubler* and give considerable power output at the second harmonic frequency instead of at the fundamental. In a similar manner, if the tank circuit L_3-C_9 should be tuned to a frequency *three times* that of the input, power will be delivered at the third-harmonic frequency; hence, the buffer behaves as a frequency tripler.

Several doubler or tripler stages can be used in cascade for even greater frequency multiplication. Two dou-

blers in cascade, for instance, would multiply the crystal frequency by a factor of four, two triplers by a factor of nine, etc. Crystal control for almost any ultra-high frequency can be obtained. All that is necessary is that the quartz crystal be ground for the proper sub-harmonic frequency, and that the correct number of doubler or tripler stages be used.

But what goes on in a doubler or a tripler circuit? How is such frequency multiplication brought about? Let us

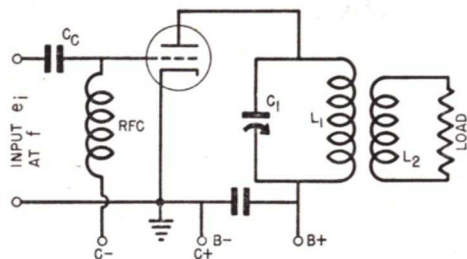

FIG. 5. When the output tank of an r.f. amplifier is tuned to some harmonic of the input frequency, such as the second, third, or fourth, it becomes a frequency multiplier.

ing through the tank coil L_1 in Fig. 5, serve to charge the tank condenser C_1 . After each plate current pulse passes, the tank circuit then oscillates because of its flywheel effect for the balance of the cycle. The total oscillating current flowing in the tank circuit L_1-C_1 then looks very much like the dashed curve shown in Fig. 6A.

This is the operation, of course, when the circuit is acting as a true amplifier and is giving "straight-through" operation so that the output

examine the performance in more detail.

HARMONIC GENERATION

In Fig. 5 is shown the basic circuit for an r.f. amplifier. We learned in an earlier Lesson that for maximum efficiency, such an amplifier is operated in class C by applying a C bias greater than the plate current cut-off value, and then supplying sufficient grid excitation to drive the grid well into the positive region on positive signal peaks. Under these circumstances, as illustrated in Fig. 6A, plate current pulses flow for only a short time (usually about 120°) during each positive half of the excitation cycle. These plate current pulses, when flow-

frequency is exactly the same as that of the input. And the important thing to note is that a plate current pulse adds energy to the output tank circuit *once each cycle*.

Action as a Multiplier. If for doubler operation, however, the tank circuit L_1-C_1 in Fig. 5 is tuned to the second harmonic instead of the fundamental, we find the action somewhat different. In this case the oscillating current in the tank circuit follows the dashed curve shown in Fig. 6B.

After each plate-current pulse passes, the flywheel effect of the tank circuit carries through, not one, but *two* complete cycles before the next plate-current pulse flows. In other words, plate current furnishes energy

to the output tank on *every other* cycle only, and in between, the tank circuit literally "coasts" along under its own power—derived, of course, from the inherent flywheel effect.

Since the plate current pulses feed energy to the tank circuit only half the time, it is reasonable to expect that the second harmonic output power will be lower than that possible at the fundamental frequency with this particular circuit adjustment. We find this to be true. In fact, the efficiency of such a doubler is just about one-half that obtainable from a straight-through amplifier and ordinarily is about 30-40%.

► The action of the circuit for frequency tripling is quite similar. If the tank circuit in Fig. 5 is tuned to the third harmonic, then the oscillating current follows a dashed curve like Fig. 6C. In this instance, plate current supplies energy to the tank on every third cycle, hence one-third of the time. In between, the flywheel effect carries through three complete cycles.

As you might expect, the efficiency of a tripler is even lower than that of a doubler. This is true because energy is supplied to the oscillating tank for such a small part of the time. Ordinarily, efficiencies between 20-30% can be obtained.

► Even greater frequency multiplication can be obtained if the tank circuit in Fig. 5 is tuned to higher harmonics such as the 4th, 5th, etc. As the number of the harmonic is increased, however, the number of cycles the tank circuit flywheel effect must complete between plate current pulses, (without energy added to the circuit) also increases. The multiplier efficiency, therefore, rapidly decreases as higher

orders of multiplication are attempted. Frequency multiplication greater than a factor of three usually is not worth while. In other words, to increase the input frequency four times, it is ordinarily better to use two doubler stages in cascade rather than a single quadrupler stage.

In spite of lowered efficiency, if the tank circuit of a doubler or tripler is not loaded too heavily, so that there is

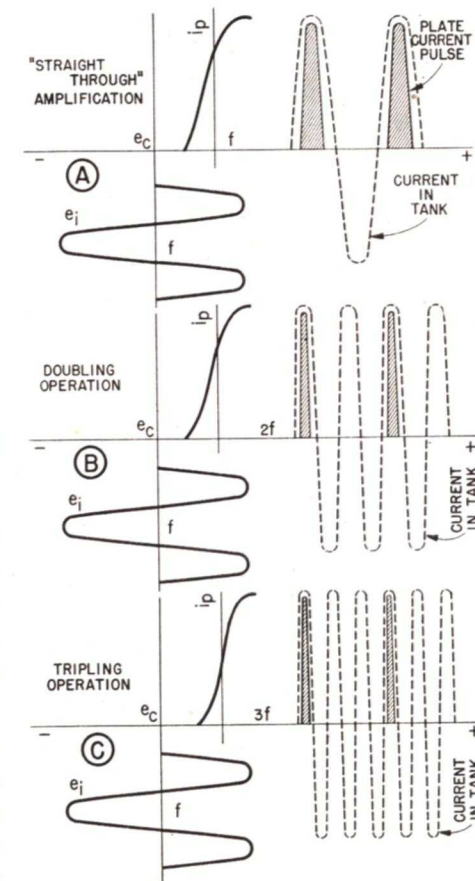

FIG. 6. In a straight-through amplifier, plate current pulses add energy to the tank circuit once each cycle, as at A. For a doubler, as at B, a plate current pulse flows every second cycle. Between pulses, the flywheel effect carries through for an extra cycle without additional energy. For a tripler, as at C, plate current flows only during every third cycle.

a high Q, and so that there will not be too much damping or "dying away" of the oscillation between plate current pulses, the wave form of the doubled or tripled frequency at the output can be surprisingly good.

Tank-Circuit Filter Effect. Another viewpoint one might take in studying the action of a frequency multiplier is to consider the impedance of the parallel-resonant output tank when this effective tube load is tuned to different harmonic frequencies of the stage input.

We know, for instance, that any parallel-tuned tank circuit like L_1-C_1 in Fig. 5 has a high impedance only at the frequency for which it is resonant, and that for all other frequencies both higher and lower than resonance, the impedance falls to a very low value.

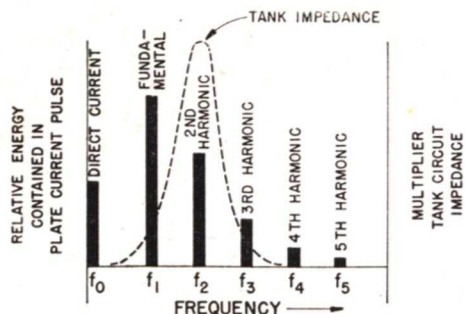

FIG. 7. A multiplier tank circuit acts as a filter because its impedance is highest, and hence, offers greatest tube load at the harmonic frequency for which it is tuned.

This change of impedance with frequency is illustrated by the dashed curve in Fig. 7.

We know, also, that the short duration plate current pulses which flow through the tank circuit in Fig. 5 and which are illustrated more clearly in Fig. 6, contain not just one frequency but a great number of frequencies. Actually, plate current pulses such as

these may contain some direct current energy, some energy at the fundamental frequency, a little less at the second harmonic frequency, still less at the third harmonic, and so on. The most important currents flowing, which when added together make up such a plate current pulse, may be scattered along the frequency spectrum like the heavy upright lines in Fig. 7.

Now, if all these currents of different frequencies are flowing through the output tank circuit of the multiplier stage in Fig. 5, the only frequency which will be amplified to any extent will be that one for which the tank circuit has the highest impedance and hence, presents the greatest tube load. Thus, if the output tank of a multiplier is tuned to the second harmonic of its input frequency, we have the situation illustrated in Fig. 7. The stage performs as a doubler simply because the tank circuit acting as tube load has its highest impedance at the second harmonic frequency. At all other frequencies the impedance of the tank circuit is very low. The undesired frequencies, therefore, are virtually shorted out.

Because it has the ability to accept energy at one frequency only and reject energy at all other frequencies, the tank circuit of a frequency multiplier actually behaves as a filter.

EFFECT OF SHAPING THE PLATE-CURRENT PULSE

If we continue to consider the output tank of a frequency multiplier as a filter which absorbs energy at only one given frequency, then it is apparent that we can get a greater output if we increase the amount of energy in the plate current pulse at that frequency.

Upon investigation, we find that the energy contained in any given harmonic is determined entirely by the shape and duration of the plate current pulses. In other words, the strength of the second harmonic, and hence, the maximum output power we can hope to get from a frequency doubler, for example, can be controlled to some extent by changing the shape of the pulses of current the tube is allowed to pass.

A Half-Cycle Sine Wave. If we were to bias the multiplier in Fig. 5, not beyond plate current cut-off as is usually done for class C operation, but merely to cut-off so that we have class B operation instead, we would find that plate current pulses exactly equal to one-half a sine wave would flow in the plate circuit. The shape and duration of these pulses are illustrated in Fig. 8A.

By mathematical analysis, it is possible to determine the amplitude of the various frequencies contained in such plate current pulses. From this, we find that these amplitudes are distributed in the frequency spectrum about like the lines in Fig. 8B. First of all, there is some energy at a zero frequency f_0 , which is simply direct current. (This is the plate current that would be read by a plate circuit milliammeter.) Next, as you might expect, most of the energy is concentrated at the fundamental input frequency f_1 . Observe, however, that the second harmonic frequency f_2 is not negligible by any means. Actually, energy at this frequency is very nearly 50% of that represented by the fundamental f_1 . Plate current pulses of the shape indicated in Fig. 8A, therefore, should make for very good doubler operation.

Higher order even harmonics such as the fourth f_4 , and sixth f_6 , etc., do exist. Their amplitudes, however, are very low as illustrated in the figure.

One interesting fact about Fig. 8B should not be overlooked. Note that all odd harmonics such as the third f_3 , the fifth f_5 , and so on, do not exist at all. In other words, the energy concen-

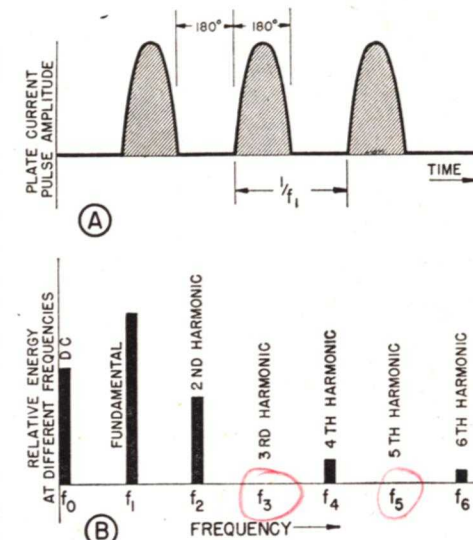

FIG. 8. Plate current pulses as at A, which are equal to one-half a sine wave, contain energy distributed as at B. Note that all ODD harmonics are zero.

trated in odd harmonics is zero. Plate current pulses shaped like Fig. 8A would not give satisfactory tripler action.

A Half-Cycle Square Wave. If instead of a half-cycle sine wave, by some means we should make the plate current pulses of a frequency multiplier resemble a half-cycle square wave as shown in Fig. 9A, we would find the harmonic content to be considerably different.

Mathematical analysis of such pulses indicates that the energy is distributed along the frequency spectrum

like the lines in Fig. 9B. As before, there is some direct current energy f_0 . Also as before, most of the energy is concentrated in the fundamental frequency f_1 . We next note, however, that the amplitude of the second har-

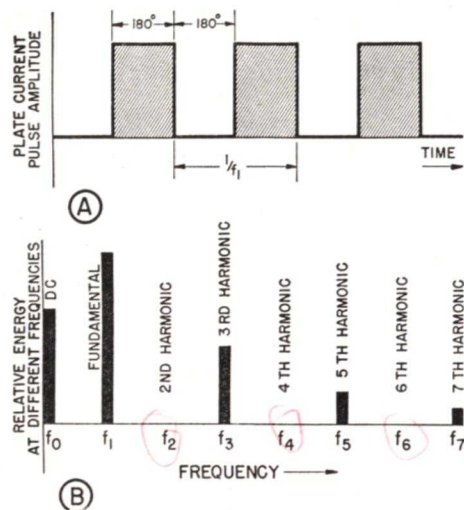

FIG. 9. Half-cycle square-wave pulses as at A contain energy at different frequencies as shown at B. Notice all EVEN harmonics have zero amplitude.

monic f_2 is zero—and indeed, this is true for all even harmonics. It is evident then that pulses shaped like Fig. 9A contain no energy whatsoever at any even multiples of the fundamental frequency, and such pulses, therefore, could not be used in a frequency doubler.

On the other hand, looking at Fig. 9B once more, we see that all odd harmonics do exist. The third f_3 , of course, contains more energy than those of higher order and actually approaches about 35% of that in the fundamental f_1 . From this, we see that square-wave plate-current pulses will give good tripler action in a frequency multiplier.

Practical Multiplier Operation.

In actual practice, neither of the plate-current pulse shapes shown in Figs. 8A and 9A are commonly used. This is true because plate current flowing half the time—and this really means class B operation—does not give as much efficiency as class C operation in which plate-current pulses are shorter and last a period of time considerably less than a half-cycle. Hence, a compromise operation is used, with the result that the pulse has a shape that gives reasonable amounts of both even and odd harmonics.

Multipliers are usually operated under the conditions shown in Fig. 10. Sufficient grid excitation is supplied to drive the plate to full saturation so that the plate current pulses become fairly flat on top in a reasonable approach to a square wave. This pulse shape we have found increases the odd harmonic output energy.

For further increase in harmonic energy in the plate-current pulses, the time duration of these pulses, and hence, the operating angle θ , is controlled by adjusting the grid bias. The higher the grid bias, the smaller the operating angle θ will be; and the shorter the time duration of each pulse, the higher the harmonic frequency that will be accentuated.

In general, it has been found that for optimum doubler operation, the angle θ should be from 90° to 120° , which means that the plate current pulses should last about the time required for $1/4$ to $1/3$ cycle of the excitation frequency. For best tripler action, the grid bias should be increased until the operating angle is reduced somewhat. For higher order harmonics such as the 4th or 5th, the angle θ should be still smaller as indicated by the table in

Fig. 10. Frequency multiplication greater than 3-to-1, however, is seldom used because of the greatly reduced output power. Incidentally, reducing the operating angle as just described increases the efficiency, because we reduce the average plate current in such a way that there is less B power used, and a greater proportion of this power is at the required output frequency. However, this reduces the

very much like the buffer amplifier illustrated in Fig. 4. In a similar manner, the triode buffer stage shown in Fig. 2 can be used as a frequency multiplier. It is merely necessary to tune the output tank L_2-C_6 to the desired harmonic and increase the C bias for optimum performance.

Neutralization Unnecessary. When a triode is used in a multiplier stage, the circuit can be simpler than that

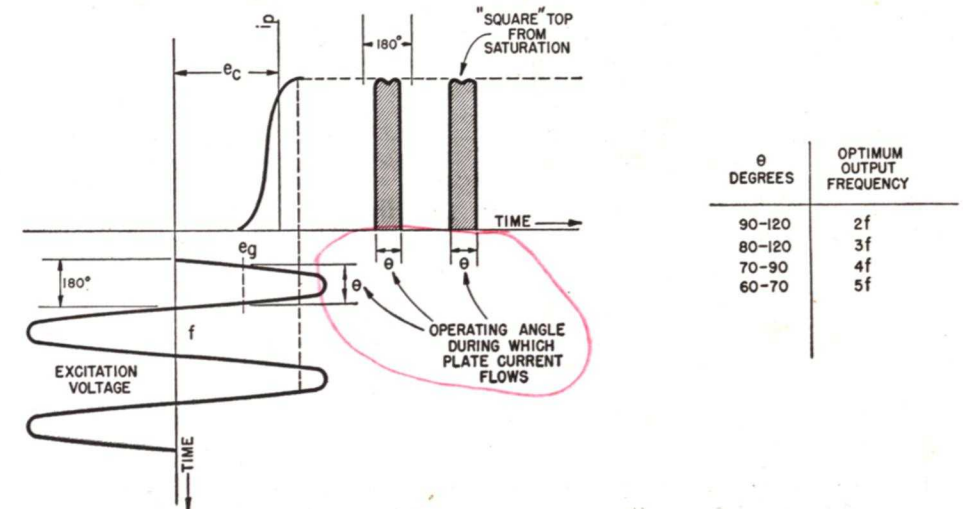

FIG. 10. In practical multipliers, the plate current pulses may be made "square-topped" by driving to saturation. The desired harmonic also is accentuated by adjusting the grid bias to obtain the optimum operating angle.

amount of output to such a low level that it is better to use multiple stages in cascade than it is to use a single high-order multiplier.

TYPICAL MULTIPLIERS

From what we have learned, it is apparent that a frequency multiplier is an r.f. amplifier in which the output tank is tuned to a harmonic instead of the fundamental input frequency itself, and the operating angle is adjusted by properly setting the grid bias and the excitation. Hence, a conventional screen-grid doubler stage would look

for straight buffer operation. You will recall that neutralization of a triode buffer is necessary to prevent self-oscillation. In a multiplier stage, however, the major voltage developed across the tank circuit does not have the same frequency as the excitation input power furnished to the stage. As a consequence, even though a considerable amount of plate circuit energy may flow back to the grid circuit through the plate-to-grid capacity, the feedback voltage can never be in phase with the input voltage because the frequencies of the two are not the same.

This means that a triode frequency multiplier cannot oscillate of its own accord and, therefore, does not require neutralization.

Accordingly, if the amplifier in Fig. 2 is to be used as a doubler or tripler instead of a straight-through buffer, the tank coil tap and the neutralizing condenser can be omitted.

To illustrate the simplicity of such a triode multiplier, let us look at Fig.

some modern ultra-high-frequency transmitters may be constructed in a slightly different manner than those just described. Special circuits may be used either to improve the efficiency of a multiplier or to reduce the number of stages necessary to get a definite multiplication ratio.

The Tri-Tet Oscillator. One of the easiest methods of reducing the required number of multiplier stages

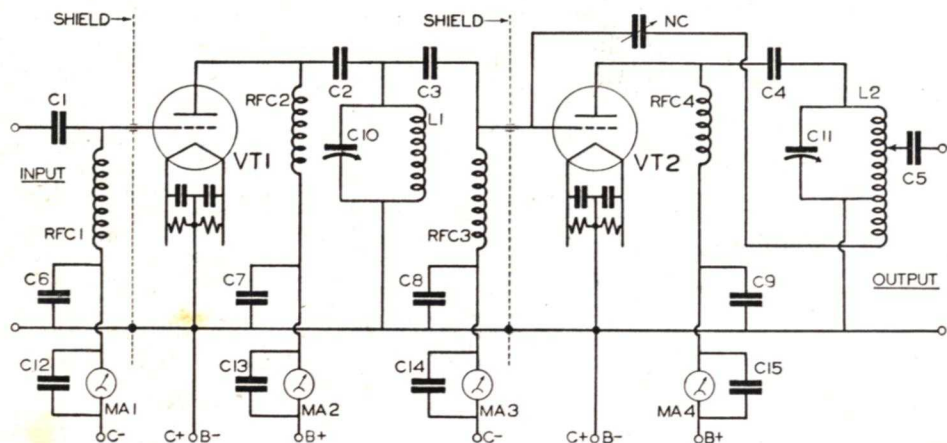

FIG. 11. A triode frequency multiplier driving a conventional "straight-through" triode amplifier. Since the plate and grid circuits of the multiplier operate at different frequencies, this stage requires no neutralization.

11. In this drawing we have VT_1 as a triode doubler (or tripler) driving a conventional triode amplifier VT_2 . Since the frequency of the voltage developed in the tank circuit L_1-C_{10} is two or three times that of the input frequency, the triode multiplier VT_1 requires no neutralization. On the other hand, since the output developed in the tank L_2-C_{11} has exactly the same frequency as the input to the grid of VT_2 , this triode stage must be neutralized to prevent self-oscillation.

SPECIAL MULTIPLIER TYPES

The frequency multipliers used in

makes use of the "tri-tet" crystal-controlled master oscillator shown in Fig. 12. In this circuit, the pentode tube performs not only as a crystal oscillator but as an electron-coupled doubler or tripler at the same time.

You studied this circuit in another Lesson. However, as a brief review: The crystal and tank L_1-C_1 are connected to the control grid, screen grid, and cathode of the tube to form the oscillator portion of the circuit. Although by-passed to ground, the screen grid really performs as oscillator plate. In operation, current finally reaching the actual plate arrives in the form of

pulses which contain relatively large amounts of harmonic energy. Consequently, if the plate tank L_2-C_2 is tuned to the second or third harmonic of the oscillator frequency, a considerable amount of double-frequency or triple-frequency output power can be obtained.

Reduction of Excitation. As you learned earlier in this Lesson, the operating angle which is optimum for

Getting this high excitation voltage becomes a problem, particularly where multipliers are in cascade and the second one is forced to work from the reduced output of the first one. One solution to this problem is to supply an excitation voltage that is sharply peaked instead of being a sine wave.

Fig. 13A shows the usually applied sine wave. Only the shaded portion that is more positive than cut-off al-

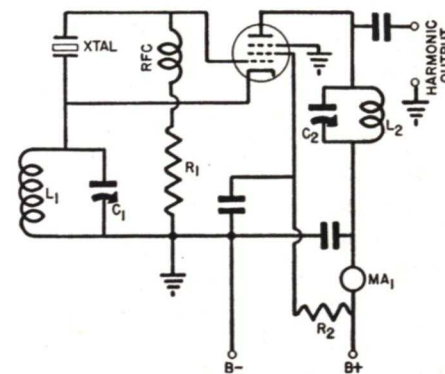

FIG. 12. The "tri-tet" circuit which performs simultaneously as crystal-controlled master oscillator and frequency doubler (or tripler).

doubling or tripling is much less than that ordinarily used in a straight-through amplifier. Hence, the grid bias of a multiplier should be greater than the usual two-times-cut-off customarily used in class C operation. Indeed, the grid bias of a frequency multiplier quite often may be three, four, or even five times the plate current cut-off value.

With such high bias, the excitation voltage necessary to drive a multiplier also becomes quite high. Multipliers, therefore, usually require greater excitation voltage than does a similar standard amplifier. (The required driving power, however, is usually less.)

lowers plate current to flow. If the optimum operating angle for a doubler is 90° , then a grid signal shaped as in Fig. 13B, at cut-off bias, would produce the same plate current pulses as does the far larger sine wave of 13A.

We can't get exactly this shape by simple means, but we can approach it by adding some *third* harmonic voltage to the fundamental. Fig. 13C shows what happens. Adding the two solid curves gives the dotted-line resultant, which is close to the desired shape. Then, by applying this signal at the proper bias level, as in Fig. 13D, we obtain the required signal pulse. Compare the bias E_c in Fig. 13D with that of 13A, and similarly compare the sig-

nal peak X of 13D with Y of 13A. Obviously, both the bias and the signal input for the 13D conditions are far less, and are easier to obtain, than those of 13A.

We can get the special wave shape of Fig. 13C by using the modified buffer-driver circuit shown in Fig. 14. In addition to the usual tank L_1-C_1 , there is an additional resonant tank composed of the tuning capacity C_2 and the center-tapped coil L_2 . (Neutralizing arrangements for VT_1 are not shown.)

The tank L_1-C_1 is tuned to the same fundamental frequency as the input. The tapped tank L_2-C_2 , however, is tuned to the third harmonic of the input frequency. Excitation to the doubler VT_2 , therefore, is equal to the sum of the fundamental voltage developed across L_1-C_1 plus half the triple-frequency voltage developed across the tank L_2-C_2 , and in general, has the wave form shown by the dotted curve in Fig. 13C. The output tank L_3-C_3 of the doubler stage itself, of course, is tuned to the second harmonic of the fundamental input frequency.

The Push-Push Doubler. A special doubler used in a great many ultra-high-frequency transmitters is shown in Fig. 15A. The outstanding feature of the circuit is that the grids of the two tubes are connected in push-pull but the tube plates are operated in parallel.

As illustrated in Fig. 15B, with excitation to the two grids 180° out of phase, the action is as follows: If during the first half-cycle of the input signal the grid of VT_1 is positive, then this tube will allow a plate current pulse to flow. During the same period, however, the grid of VT_2 will be nega-

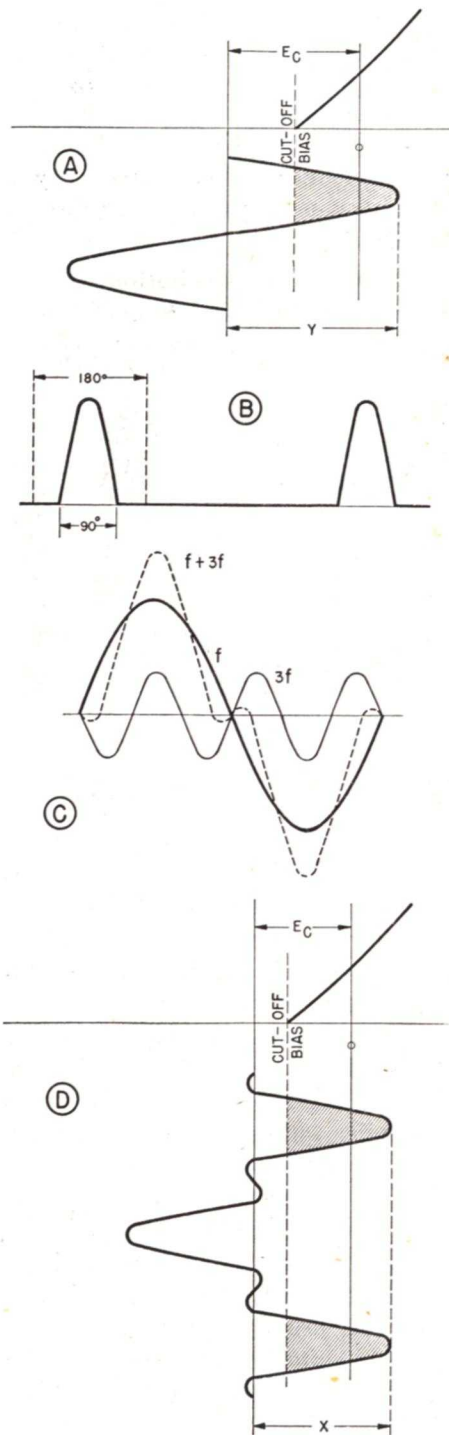

FIG. 13. Shaped pulse reduces drive needed.

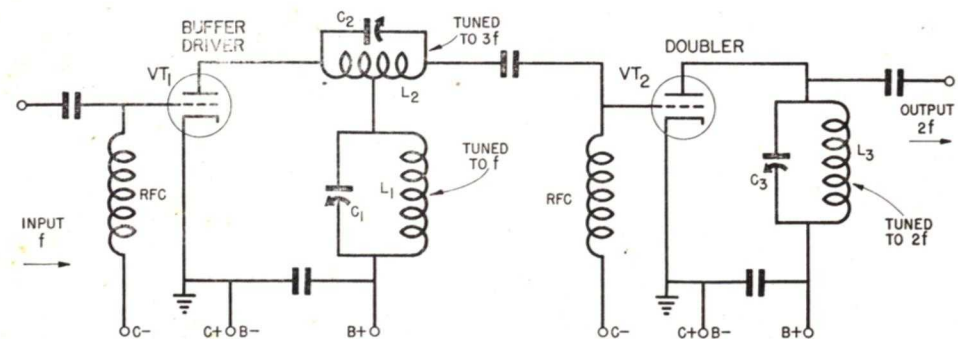

FIG. 14. This buffer circuit feeds a "shaped" pulse to the doubler, so that far less excitation and less doubler bias are necessary than in the conventional frequency doubler stage already studied.

tive so that this tube is blocked. During the next half-cycle of excitation, the conditions will be reversed. The grid of VT_1 will become negative so that the plate current of this tube will cease, but the grid of VT_2 will become positive, allowing plate current to flow.

The output tank circuit L_2-C_2 , therefore, passes *two* plate current pulses for every single cycle of the input frequency—first that of one tube, then that of the other. (From this action, this is sometimes called a "push-push" circuit.) And because of the parallel plate connection, these pulses flow through the output tank in the *same* direction. Thus, if the tank L_2-C_2 is tuned to a frequency *twice* that of the input, a large amount of second harmonic power can be obtained.

Since the output tank receives energy from a plate current pulse once *each* cycle of the doubled frequency and not on *alternate* cycles as in the more conventional doubler circuit, the output power is exactly twice as great. The peculiar push-push arrangement, also, makes a circuit which is unusually stable and one which very seldom gives trouble with spurious or parasitic oscillations. The doubler does have the disadvantages, however, of requiring

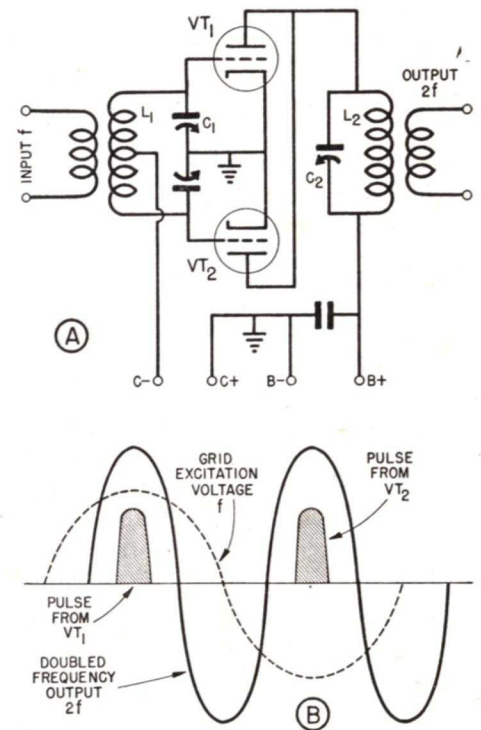

FIG. 15. The "push-push" doubler which uses two tubes with grids in push-pull and plates in parallel. Since twice as many plate current pulses flow through the output tank, this doubler gives twice the output power of a conventional single-tube circuit. This basic idea can be extended to obtain third harmonics, for example, by applying a three-phase voltage to the grids of three tubes, and tuning the common plate circuit to the third harmonic.

two tubes instead of one, and in addition, some means of 180° push-pull grid excitation must be supplied.

PHASE MULTIPLICATION

One of the important characteristics of a frequency multiplier in addition to multiplication of input frequency is its ability to multiply as well any *phase changes* which may occur in the input signal. This is extremely useful

with each other, in such a way that the original signal peaks are speeded up (or slowed down) with respect to their normal positions.

When this phase-modulated signal is fed to the frequency doubler, the mean or average frequency, of course, will be doubled. We find also, however, that the doubled frequency has a maximum phase change or swing which is also twice as great and varies between the limits of plus or minus 40° .

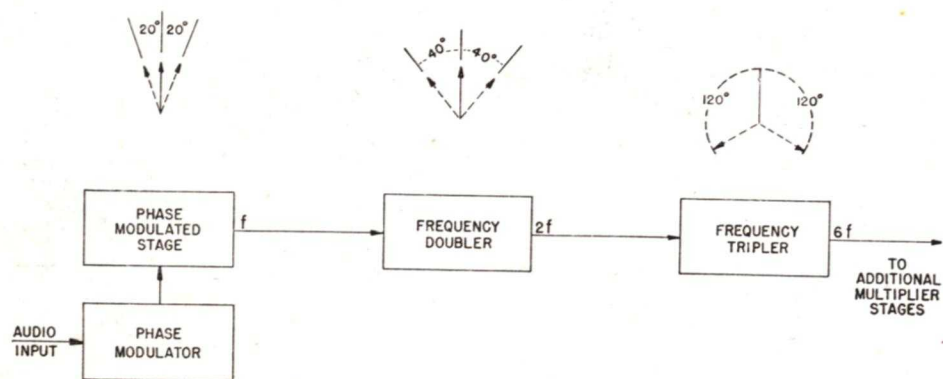

FIG. 16. Frequency multipliers are used in phase-modulated transmitters to multiply phase changes of the master oscillator. One doubler and one tripler not only increase the oscillator frequency six times but also multiply phase variations by the same factor.

in ultra-high frequency transmitters using phase modulation or frequency modulation.

You are going to study frequency (and phase) modulation in a later Lesson. However, as an illustration of what happens, suppose the first three stages of an ultra-high-frequency transmitter consist of a phase-modulated stage, a frequency doubler, and a frequency tripler as shown in Fig. 16. Let us suppose further that an audio-frequency input to the phase modulator can shift the phase between r.f. cycles as much as plus or minus 20° . This is accomplished by adding together signals that are out of phase

This comes about because the phase shift—speeding up or slowing down in phase—produces a change in *frequency* also, because we have changed the time of completing the cycle. Therefore, if the original frequency is doubled, so will the frequency change be doubled, and hence the phase shift is equivalently doubled.

In a similar manner, when the doubled frequency is fed to the frequency tripler both the average frequency and the limits of phase change will be increased again, this time by a factor of three. The mean frequency at the output of the tripler, therefore, is six times that of the master oscil-

lator, while the instantaneous phase may vary plus or minus 120° .

Practical ultra - high - frequency transmitters may use a large number of doublers and triplers to get an over-

all frequency multiplication of say, 30 to 40 times, and small phase changes are multiplied to the same degree. At the output frequency, therefore, very large phase swings can be obtained.

Basic Output Stages

Up to this point we have considered the relatively low-power buffer stage directly following the master oscillator, and the succeeding amplifiers, or multipliers, which have been used to isolate the oscillator from any load changes and at the same time to raise the r.f. power up to a satisfactory level for driving the output stage. We shall now investigate the high-power output stage itself, which instead of working into a following amplifier, delivers its output power into the antenna system, either directly or through a transmission line.

Referring to the early part of this Lesson, you will remember there are two different types of output stages. In the low-level modulation system wherein amplitude modulation is carried out in a low-level r.f. stage, the excitation to the output stage is a fully modulated wave, and it is necessary that the final stage be a class B linear amplifier, because class B operation alone will give high-power output that varies in amplitude in exactly the same manner as the *variable* excitation from a modulated input. A more detailed discussion of this type of amplifier is reserved for a later Lesson.

► At this time we will be concerned with output stages for which the excitation driving power is *constant*, as in a high-level modulation system. Even though the plate of the output stage be

modulated by a high-power audio modulator, the r.f. driving power furnished to the grid is kept steady and unvarying.

Constant excitation to the output stage is used in c.w. radiotelegraph and frequency - modulated transmitters, also. In the former, output stage excitation may be turned on and off by keying, but during "key-down" conditions the excitation is fixed at a constant level. In an f.m. transmitter, of course, there is no amplitude variation of r.f. voltage of any sort at *any* point since modulation is accomplished by "swinging" the frequency back and forth.

In all these applications, with excitation maintained at a fixed level, it is possible to operate the output stage in class C. This is always done to get the highest possible efficiency. We find then that the class C output stage is very similar to the class C amplifier we have just finished studying. Indeed, the only difference between the two is that the output stage usually works at a higher power level and delivers power to an antenna instead of a following amplifier.

CLASS C OUTPUT STAGE

In Fig. 17 is given the circuit of a common type of output stage. Comparison to the buffer amplifier illus-

trated in Fig. 2 shows there is very little difference between the two types of amplifiers.

This particular output circuit uses a triode tube which, of course, must be neutralized to prevent self-oscillation. Screen-grid tubes would eliminate the need for neutralization, but the only tubes made for very high

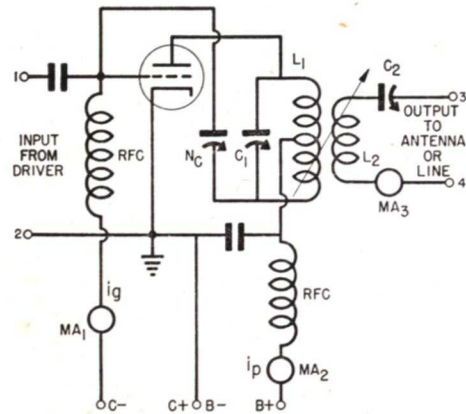

FIG. 17. The basic neutralized-triode output stage. Operated in class C, it is practically identical to the buffer amplifier. The main difference is that the output stage delivers higher power and works into an antenna or transmission line instead of a following amplifier.

power levels are triodes. Hence, you will find screen-grid output stages only in the low-power transmitters. Furthermore, where the stage is modulated, the use of a screen-grid tube sometimes makes it difficult to get 100% modulation without distortion. For this reason, high-level modulation systems ordinarily employ triode output stages even though neutralizing is necessary.

Class C Operation. To refresh our memory, let us review for a moment just what class C operation is.

As illustrated in Fig. 18, the fixed grid bias E_c applied to the output stage is approximately twice the plate-cur-

rent cut-off value. Without excitation, therefore, the plate current of the stage will be zero. Excitation from the driver, however, (which is a preceding r.f. amplifier) is made very high. In fact, the input voltage to the grid is made so great that the grid is carried far into the positive potential region. The grid draws pulses of current under these conditions so that a considerable amount of average grid current i_g , which is designated by the dashed line A-B in Fig. 18 and which will be measured by the milliammeter MA_1 in Fig. 17, indicates that the grid is dissipating a definite amount of power, and indeed, this driving power must be furnished by the driver stage.

The time duration of the plate current pulses, however, is important. For maximum efficiency they should not last as long as a half-cycle. On the other hand, pulses too narrow will result in reduced power. In actual practice, the grid bias is adjusted until the operating angle θ is approximately 120° .

These plate current pulses pass through the output tank L_1-C_1 in Fig. 17 and serve to supply energy to the tank circuit. Because of the flywheel effect, the actual oscillating current flowing in the tank circuit itself will look much like the dashed sinusoidal curve shown in Fig. 18.

For maximum power into the tank circuit it is imperative that the impedance of the tank circuit—and this is really the load into which the tube must work—be approximately equal to the a.c. plate resistance of the tube.

When all these operating conditions are met, the class C output stage in Fig. 17 will give a plate circuit efficiency between 70 and 80%, which

simply means that approximately 70% of the B-supply power supplied to the stage will be converted into r.f. power and transferred to the antenna load, while the remaining 30% will be dissipated in the form of heat at the tube plate.

► The actual over-all power gain of the stage, that is, the ratio of r.f. output power to the exciting power furnished by the driver, will be limited

In the first place, what is the tube plate resistance? Since the plate current is not steady but flows in pulses, the tube resistance also varies in value over an oscillation cycle. For practical purposes it is assumed that the effective a.c. plate resistance is equal to the applied plate voltage divided by the average plate current flow under full load. In other words, if the B-supply voltage supplied to the tube in Fig. 17

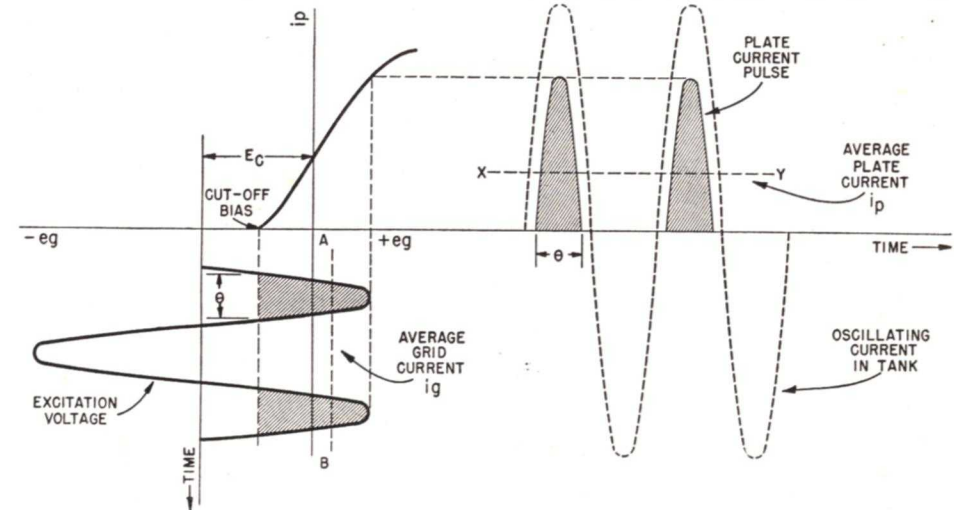

FIG. 18. For class C operation, a tube is biased to twice cut-off, and the excitation is adjusted to give plate current pulses with an operating angle of about 120° .

primarily by the amount of power that can be dissipated in heat by the grid and plate of the output tube. In ordinary instances, this power gain is approximately equal to the amplification factor of the tube; this is, however, by no means an accurate rule.

IMPEDANCE MATCHING

Let us go back for a moment to the statement that the impedance of the tank circuit in Fig. 17 must be equal to the a.c. plate resistance of the tube for maximum power output.

is divided by the plate current (in amperes) as read by the plate current meter MA_2 , the result is the apparent resistance of the tube. It is this resistance that the tank circuit must match in order for a maximum amount of power to be transferred first to the tank circuit and finally to the antenna.

But now, what is the impedance of the tank circuit in Fig. 17? We shall find that this is determined by both the L/C ratio and the effective Q of the tank. And the Q, in turn, will be determined firstly by how closely the antenna is coupled to the tank circuit

through the antenna coupling system, and lastly by the exact impedance the antenna or transmission line itself may have. In order to analyze conditions properly, therefore, we must first determine the nature of the impedance which may be attached to the output terminals 3-4 in Fig. 17.

Antenna Impedance. As we shall discover in a later Lesson, the impedance of an antenna which is reflected into the output stage tank is no definite quantity but one that depends upon how the antenna is connected. Thus, if either the antenna itself or a *tuned* transmission line for remote feed is attached to terminals 3-4 in Fig. 17, the effective impedance shunted across them may be as low as 72 ohms or as high as 20,000 ohms. On the other hand, if an *untuned* transmission line such as a concentric cable is used, the resistance across terminals 3-4 may be as low as 20 to 30 ohms.

But in using any *tuned* transmission line or directly-coupled antenna, the output network is always tuned to resonance. Thus, by means of condenser C_2 in Fig. 17, leakage inductance of the pick-up coil L_2 plus any inductance of the antenna or transmission line itself is tuned out. Even with other forms of coupling, similar methods of tuning are used.

An untuned line, such as a coaxial cable, does not require tuning. The tuning condenser C_2 , therefore, would be omitted. In this instance, however, the cable itself behaves as a pure resistance with negligible amounts of inductance or capacity.

This brings out the important fact that *no matter what sort of antenna system is used or what sort of output coupling is employed, if adjusted prop-*

erly, the load will appear as a pure resistance.

► This means then, that as far as the tank circuit L_1-C_1 in Fig. 17 is concerned, the most important effect of coupling the load is to increase the effective resistance in the tank circuit, which lowers the tank circuit Q , and hence its impedance. The closer the load is coupled, the higher will be the apparent resistance reflected into the output tank.

Low Tank-Circuit Q . The closer we make the coupling between the tank coil L_1 and pick-up coil L_2 of Fig. 17, the greater the power delivered to the antenna load. We cannot go too far in this direction, however, because the apparent resistance reflected into the output tank from the antenna load will become so high that the Q will be dropped to a low value and the tank circuit flywheel effect will be impaired.

You know that a tank circuit having a high effective Q has a very good flywheel effect. Even though plate current flows in pulses, the oscillating current in the tank circuit will be a very nearly perfect sine wave.

On the other hand, if the Q is very low because of resistance—and this means both the normal resistance of the coil and condenser plus that reflected from the load—the oscillating current will be very distorted. What actually happens is that the resistance of the circuit absorbs so much power there is very little left for the flywheel effect to carry through, and during the negative alternations the tank circuit will not reach its normal peak value. It tends to die out before the next plate current pulse, so the wave is distorted. This means that the tank circuit produces severe harmonic distortion. In-

deed, if a class C output stage were operated in this manner, its efficiency would be low because a great deal of power would be wasted in generation of harmonic frequencies. Furthermore, if the harmonics were allowed to reach the antenna, very serious interference with other services might result.

How low a Q value can we use in actual practice without wasting too much energy in harmonics? Engineers have found that the third harmonic energy usually is small and does not become noticeable until the Q factor approaches the relatively low value of about 5. Power in the second harmonic, however, rises very sharply for Q 's less than 12.

High Tank Q . But why not operate the class C output stage in Fig. 17 with a very *high* tank circuit Q so that a good flywheel effect will result and the harmonic output will be reduced to a very small per cent? There are three principal reasons why this is not done.

In the first place, in order to get a high tank Q , the antenna load must be coupled very loosely so that little resistance will be reflected into the tank circuit. This means, of course, that the available output power will be seriously reduced.

As a second reason, with very little power delivered to the load, the oscillating current flowing between the inductance L_1 and capacity C_1 of the tank circuit will increase enormously—reaching in some cases, 20, 30, or even 50 amperes, depending upon the power of the stage. This high current, in flowing through the normal resistance of the tank coil, will dissipate considerable power in the form of heat. The efficiency of the stage, therefore, is

definitely reduced by these losses.

Finally, if the tank has too high a Q value, its frequency selectivity will be excessive. As an example, suppose the class C stage in Fig. 17 is plate-modulated. In this instance, the impedance of the tank circuit should be adequate, not only for the carrier frequency, but for any side-band frequencies present.

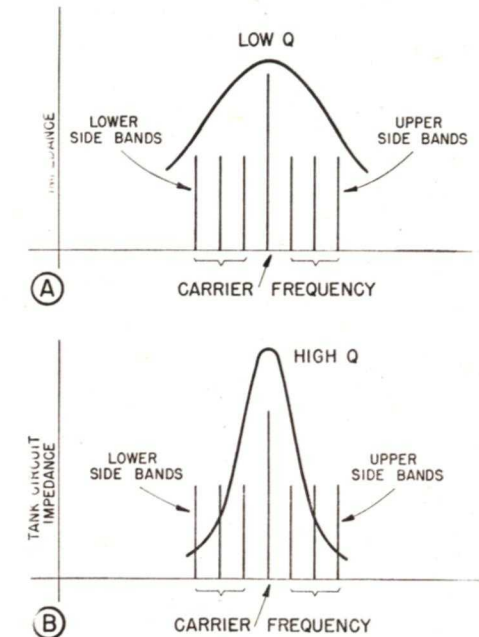

FIG. 19. A low- Q tank has very nearly equal impedance to carrier and side bands so that all receive approximately identical amplification. A high- Q tank results in "side-band clipping" because the tank impedance is low for the remote side bands and these cannot be given equal amplification.

Thus, as shown by the curve in Fig. 19A, a *low* Q tank would be best because the impedance to the side bands is very nearly the same as that for the carrier, and both carrier and side bands would be amplified with nearly the same intensity.

On the other hand, if a *high* Q tank is used, as illustrated in Fig. 19B, the selectivity may be so great that the

more remote side-band frequencies are cut off, and hence, cannot be amplified as well as the carrier frequency itself.

This discrimination against the higher order side bands is referred to as "side-band clipping." It can result in distortion because the higher audio frequencies will not be reproduced at the proper level.

Optimum Tank Q. From what

tion it has been found that optimum tank circuit Q lies between the values 12 and 15. These values make the class C amplifier as efficient as possible without increasing the harmonic energy output beyond a tolerable level.

Now that we have found the tank L_1-C_1 in Fig. 17 must not only have an impedance which matches the effective a.c. resistance of the tube but also a Q

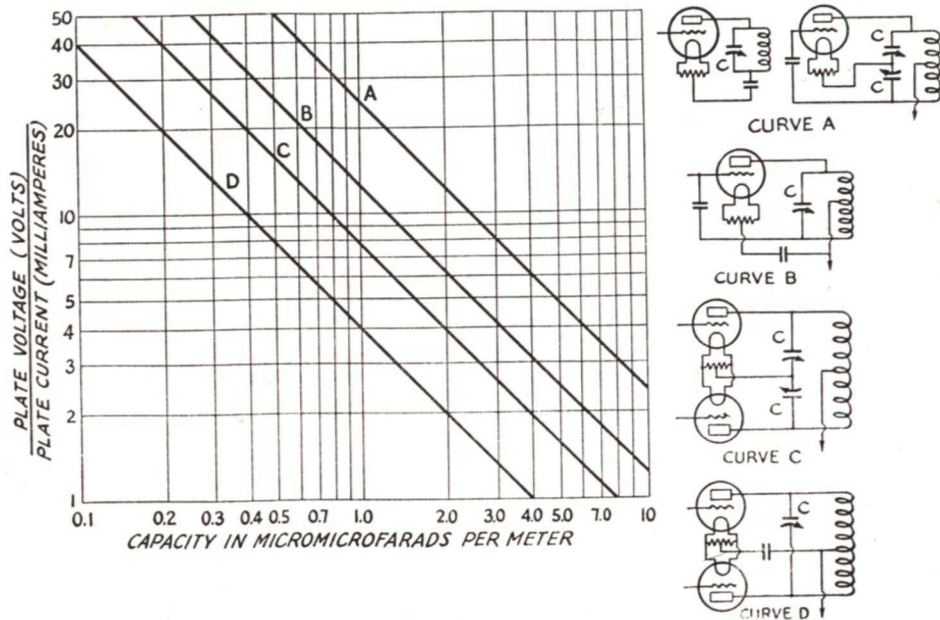

FIG. 20. The graph shows how the optimum capacity values vary with the ratio of plate voltage to plate current. The curves are lettered to correspond to the figures at the right. (This data is taken from "The Radio Amateur's Handbook," published by the American Radio Relay League, and is published with their kind permission.)

we have just discussed, it is obvious that the Q of a class C output stage tank circuit must be a compromise. We cannot use too *high* a Q because of low output, low efficiency, and danger of side-band discrimination. But we cannot use too *small* a value of Q because the flywheel effect is reduced and the energy wasted in harmonics increases to result again in low efficiency.

In practical transmitter construc-

tion it has been found that optimum tank circuit Q lies between the values 12 and 15. These values make the class C amplifier as efficient as possible without increasing the harmonic energy output beyond a tolerable level.

Ordinarily, we can assume that the tank circuit, without a load, will have a Q far higher than 12. Then, when the load is properly coupled, the Q will drop to this required value. By following good design practices to make the tank Q high, we can find the needed value of inductance as follows:

1. The impedance of the loaded tank must equal the plate resistance, and is X_L multiplied by Q. Hence, dividing r_L by Q gives X_L .
2. Knowing the frequency,
$$L = X_L \div (2\pi f)$$

The proper tuning capacity can now be found. However, as an alternate method, many designers find the capacity values first. The practical reason for this is that only certain standard tuning condensers are available, whereas coils can be made to order. Hence, it is best to be sure of getting the condenser value within the range of a standard size.

Furthermore, the L/C ratio will affect both the impedance and the Q of the tank circuit. By finding the condenser value first, we can more easily get the optimum L/C ratio.

As an example of how the L/C ratio changes with the impedance value, look at Fig. 20. This graph was prepared for an assumed Q of 12 (loaded). Curve B is for the circuit shown in Fig. 17; the other curves are for other circuits.

As an example of how the chart is used, let us suppose the output stage in Fig. 17 under full load draws an average plate current of 200 ma. at a

B-supply voltage of 5000 volts. Next, we determine the ratio, which is $5000 \div 200 = 25$. (The plate resistance is this ratio multiplied by 1000, so it is 25,000 ohms.) Finding the ratio number 25 on the left-hand scale of the chart in Fig. 20, we move across to the right until we reach the curve B. At this point we drop down to the capacity scale along the bottom and find a capacity value of approximately 0.5 micromicrofarads per meter. To find the actual capacity needed, we must know the operating wavelength (or frequency). If we are working at 2 megacycles, which is about 150 meters, the capacity then should be $.5 \times 150 = 75$ mmfd.

This value of 75 mmfd. is the *minimum* that should be used in the circuit of Fig. 17. No smaller capacity should ever be used, or the harmonic energy in the output will be increased seriously. In some cases it is even advisable to use a somewhat higher capacity even though the output of the stage will be reduced slightly. Also, it is important to note that this is the capacity needed for resonance—not the maximum capacity of the tuning condenser. You would use a standard 100 or 150 mmfd. condenser.

Practical Facts About Output Stages

The main purpose of a class C output stage is to deliver high output power, and in most cases such stages are operated at extremely high voltages. All components in the circuit, therefore, such as by-pass condensers, resistors, tube sockets, etc., must be of satisfactory voltage rating, and must be adequately insulated to withstand these voltages without danger of breakdown.

Furthermore, we know that about 30% of the power fed to an output stage is wasted in heat. For a 50-kilo-watt stage, about 15,000 watts will be lost in this way. Most of this power serves to heat up the plate of the tube and a smaller part of it is lost in the tank inductance. It is obvious, then, that some form of cooling usually is necessary to carry off this heat.

Cooling of Tubes. Most high-power tubes are large in size simply because they must be in order that their plates can dissipate large amounts of heat without melting. For moderate powers, a tube may be cooled sufficiently if it is merely exposed to open air so that heat may be carried off by convection air currents. Better cooling is obtained and more power can be handled if a fan blast is directed over the glass envelope. Some air-cooled tubes are made with metal fins very much like those on a motorcycle engine in order that more surface will be exposed to the air, and heat will be lost more rapidly.

For extremely high powers, water-cooled tubes are most often used. These special tubes are made by using a cylindrically shaped copper plate,

one end of which is sealed, and fusing the open end to a glass envelope. By this means of construction (which you will study later), the outside of the tube plate is exposed and can be inserted in a distilled water circulating system which will carry off extremely large quantities of heat.

The Tank Inductance. In high-power installations, the tank coil, too, usually is large in size. Large physical dimensions are desirable to prevent arcing or voltage breakdown between turns, to make the resistance as low as possible and to provide adequate surface for dissipation of heat.

Tank inductances are often made of edge-wound, heavy copper ribbon. Normally, air-cooling is adequate, though in some cases forced air draft may be used. In extreme cases, the tank coil may be wound from large copper tubing with distilled water circulated through it for cooling.

The Tank Capacity. Since little power usually is lost in the tank condenser of a high-power stage, this capacity ordinarily does not require cooling. It is subjected, however, to extremely high surges of voltage and must be designed to withstand these without failure.

If the condenser is of the air-dielectric type, the spacing between the plates may need to be quite large—perhaps half an inch or more. All plates also must be polished and have rounded edges so that no sharp points are present from which a corona discharge can take place and perhaps initiate a breakdown.

With such extreme plate spacing,

the physical size of an air condenser required for a given capacity may be enormous. For smaller size, vacuum-type condensers are sometimes used. These are merely two plates placed close together and sealed in a glass bulb from which air has been removed, similar to a vacuum tube. Such condensers, though small in size, can withstand enormous voltages. These condensers, of course, are fixed, and

practice is often necessary, because one tube alone ordinarily cannot handle the desired power.

Parallel Operation. The simplest way of using a number of tubes is to connect them in parallel, that is, connect all grids together, all plates together, and so on. Fig. 21 shows how two tubes can be operated in parallel. Any number of tubes can be used in this manner.

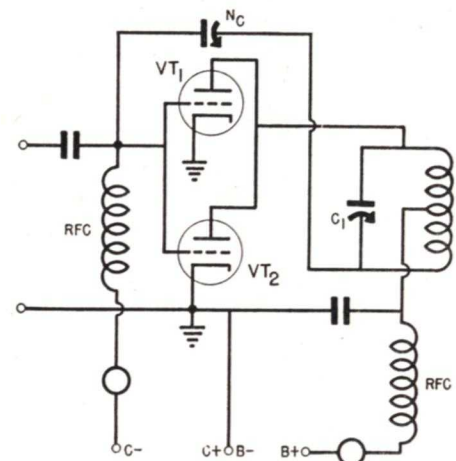

FIG. 21. The output power of a class C stage can be increased by operating two or more tubes in parallel.

their capacity cannot be adjusted. They are useful, however, because when connected in a tank circuit they can contribute the bulk of the capacity needed. For tuning, a relatively small variable air condenser then is connected in parallel.

MULTIPLE TUBE OPERATION

The output power of any class C stage can be increased by using a number of tubes in the same circuit. Thus, two tubes will double power, four tubes will increase the output by four, etc. For very high power installations this

Actually, the circuit in Fig. 21 is identical to the circuit given in Fig. 17, except that two tubes are used instead of one, consequently some of the component values have to be altered.

Since the plate-to-grid capacity of two tubes is exactly double that of a single one, the neutralizing capacity NC must be doubled in size. Also, since the plate resistances of the tubes are in parallel, the effective plate resistance shunted across the tank circuit is halved. This means the tank condenser C1 must be twice as large as before in order to get a Q of 12.

Because the plate current is twice as great, the parallel stage in Fig. 21 will deliver exactly double the power obtainable from the single-tube stage in Fig. 17. Two tubes, however, draw twice as much grid current and this means they also require twice the driving power.

Push-Pull Operation. A more complicated but more efficient manner of using two tubes is to connect them in

other, these pulses pass through the center-tapped output tank coil L_2 in *opposite* directions. As illustrated in Fig. 23, these pulses occur alternately at the proper time and in proper phase to build up a very nearly pure sinusoidal tank current.

Because the tank circuit reconstructs a nearly pure sine wave if it receives equivalent pulses from the two tubes, the *even* harmonic distortion

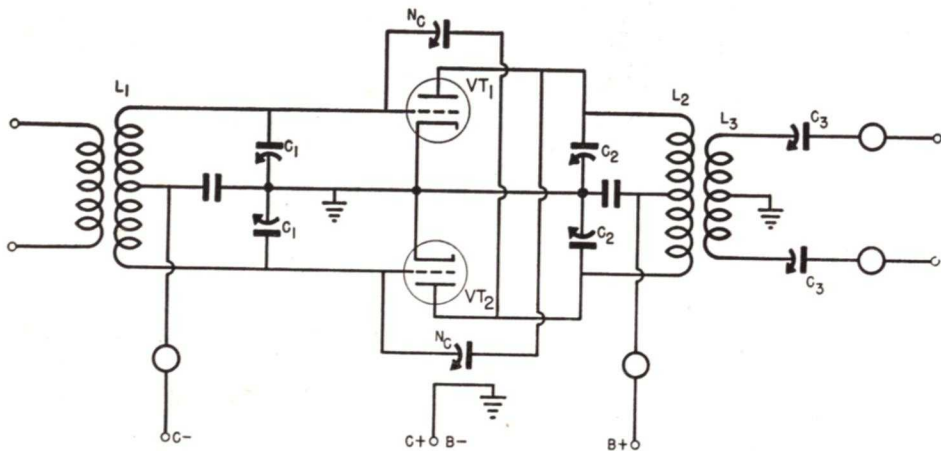

FIG. 22. Two tubes operated in push-pull will not only give twice the power of a single tube, but if the circuit is perfectly balanced, all even-harmonic distortion in the output will be reduced to zero.

push-pull as shown in Fig. 22. In this arrangement, because of the center-tapped grid tank coil L_1 , excitation to the two grids is equal in amplitude, but 180° out of phase. Thus, when the grid of VT_1 is positive so that this tube draws current, the grid of VT_2 will be negative and this tube will be blocked. On the next half-cycle of excitation, however, the polarities will be reversed. VT_1 will be blocked because of a negative grid while the positive grid potential of VT_2 allows full plate current to flow.

Even though plate current pulses flow first through one tube, then the

produced by each tube will not appear across the output that is coupled to the tank. In other words, for a perfectly balanced push-pull stage like Fig. 22, the second harmonic energy in the output (as well as that of the fourth, sixth, etc.) will be zero.

To make the circuit balance as nearly perfect as possible, almost all push-pull stages use twin tuning condensers in both input and output tanks as illustrated. Even the antenna load circuit may be designed to employ a center-tapped coil and dual tuning capacitors. This construction equalizes all stray capacities and inductances of

leads, etc., so that second harmonic output can be reduced to a minimum. ► But low second-harmonic output is not the only benefit offered by push-pull operation. If you look at Fig. 23 you will notice that the tank circuit is fed energy *twice* each cycle. The plate current pulse of VT_1 supplies energy during the first half-cycle, and the pulse of VT_2 for the second half-cycle. It is obvious, then, that a push-pull circuit does not depend to a great ex-

deliver slightly more than twice the output power.

HARMONIC SUPPRESSION

In a previous part of this Lesson we discovered the plate current pulses drawn by a class C amplifier contain a relatively large amount of harmonic energy. As a matter of fact, we found that the frequency multiplier takes advantage of this characteristic, its

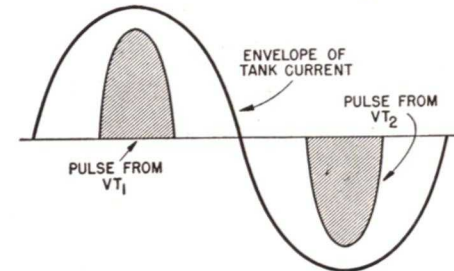

FIG. 23. When two tubes are used in push-pull, one tube passes plate current and hence charges the tank condenser during the first half-cycle, and the second tube passes current during the second half-cycle.

tent upon the tank circuit flywheel effect in producing a sine-wave output.

These two factors—zero second harmonic output and little need for flywheel effect—indicate that the Q of the tank circuit need not be kept at a value of 12. Indeed, the Q need be only of sufficient value to reject the *third* harmonic which is not cancelled out. The third harmonic is not objectionable for a Q as low as 6. This is just half the value required for a single tube amplifier, and actually is the value commonly used in push-pull stages.

This lower Q value is obtained mainly by closer coupling between the load and the tank circuit. Push-pull circuits, therefore, are somewhat more efficient than single-tube stages and

plate tank acting as a filter to select the desired harmonic frequency.

In an output stage, however, harmonics definitely are not desired. They not only represent a waste of energy but if allowed to reach the antenna system they can cause serious interference.

We already know that harmonics can be reduced if a high Q tank circuit is used. We cannot use a Q factor much greater than 15, however, if a reasonable amount of output power is to be obtained.

Of course, push-pull operation reduces second harmonic energy to a very small value, and for this reason the use of such stages is recommended. The output of a push-pull amplifier,

however, may contain relatively large amounts of *third* harmonic power. From these limitations it is obvious that any practical transmitter may generate objectionable harmonics, and some means of preventing these from

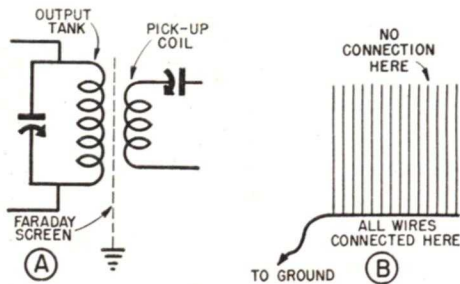

FIG. 24. By placing an electrostatic shield or Faraday screen between the output tank and the antenna pick-up coil, harmonic currents can be prevented from flowing through the capacity between the coils.

reaching the antenna system must be devised.

The Faraday Screen. Since harmonics are higher in frequency than the fundamental, they can pass quite easily through very small capacities. A great amount of harmonic energy can flow through the capacity between the output tank and antenna pick-up coils.

To prevent this, it is usually advisable to place an *electrostatic* shield between the coils as shown in Fig. 24A. This shield, or "Faraday screen" as it is usually called, is made up of a number of spaced parallel wires as illustrated in Fig. 24B. Spacing ordinarily is about the diameter of the wire. The wires are all connected together at one end only and this lead is attached to ground. Since the wires are open at one end, they cannot act as shorted turns, and hence, do not interfere with the normal coupling between the coils. Thus, this screen does not interfere

with the magnetic field. However, it is at ground potential and acts as one plate of a condenser with the coil acting as the other. Hence, it is an effective electrostatic shield.

Wave Traps. An alternative method of reducing harmonic currents in the antenna system is to insert wave traps tuned to the harmonic to be eliminated. As shown in Fig. 25A, if the parallel resonant circuit L_3-C_3 is tuned to a harmonic, the impedance presented to the harmonic current will be very high. If a series resonant trap such as L_3-C_3 in Fig. 25B is shunted across the pick-up coil, the harmonic current for which it is resonant will be shorted out.

The presence of these traps, of course, will modify the value of the tuning capacity C_2 necessary to bring

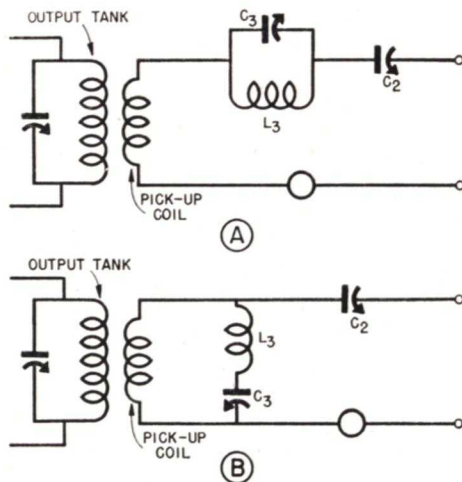

FIG. 25. Two methods of using wave traps to prevent the flow of harmonic currents in the antenna system.

the entire system to resonance at the desired fundamental frequency. It is usually possible, however, to tune the antenna system in a normal manner.

Pi-Section Couplers. One of the best methods of reducing harmonics is

to use a special coupling network between the output tank and the antenna or the transmission line. You will study these in more detail later. However, briefly, these networks are named from the positions of the parts; Fig. 26 shows a commonly used type known as a pi-section coupler.

This network serves two purposes: By individual adjustment of the con-

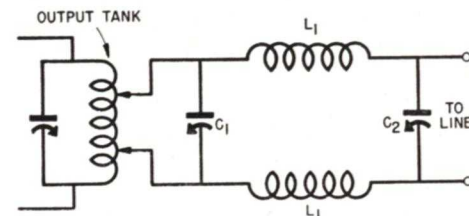

FIG. 26. This pi-section coupler not only provides a good impedance match between the transmission line and output tank, it also prevents the flow of harmonics because it behaves as a low-pass filter.

densers C_1 and C_2 it is possible to achieve a very good impedance match between the tank and the low-impedance line, which means a maximum amount of power transfer. The network also behaves as a low-pass filter. Therefore, if tuned just above the fundamental frequency, it passes the desired fundamental signal with very little loss, but it presents a very high impedance to all harmonic frequencies.

PARASITIC OSCILLATIONS

It sometimes happens that a class C output stage will burst into self-oscillation even though it is perfectly neutralized. As a general rule, these spurious oscillations (more often called "parasitic" oscillations) do not occur at the frequency of transmission but at either some very low frequency or an ultra-high frequency. Energy spent

in generating parasitics is energy wasted. The presence of parasitics, therefore, reduces the efficiency of the amplifier. Parasitics, also, could cause severe interference if they should reach the antenna system and be radiated.

Low-Frequency Parasitics. Spurious oscillation at a low frequency is

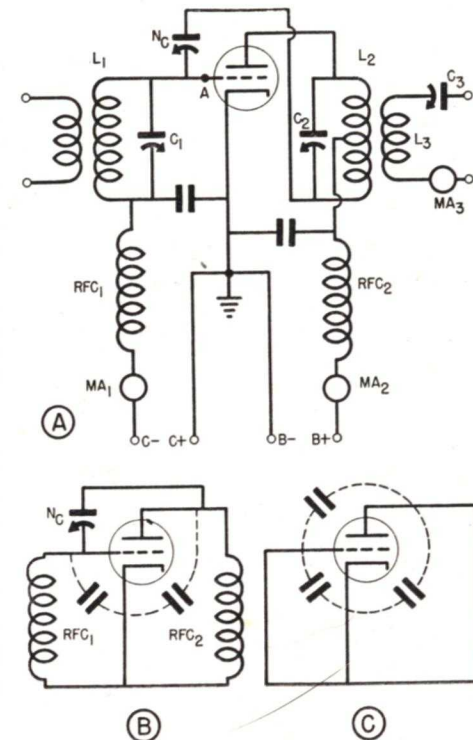

FIG. 27. A typical class C output stage is at A. At B and C are two oscillator circuits, derived from the amplifier, that can be responsible for low-frequency or ultra-high-frequency parasitic oscillations.

usually caused by the r.f. chokes in the amplifier performing as low-frequency tank inductances.

Suppose we have the triode amplifier illustrated in Fig. 27A. At very low frequencies it is obvious that the reactances of the grid coil L_1 and the plate coil L_2 will be negligible. For a low frequency then, we can say the

amplifier circuit can be considered as the simplified circuit in Fig. 27B. Note that the high-inductance r.f. chokes, together with the interelectrode capacities of the tube, form a tuned-plate-tuned-grid oscillator. If the plate choke RFC₂ happens to be tuned to a slightly higher frequency than the grid choke RFC₁, then the plate circuit will be inductive so that the amplifier will break into low-frequency oscillation. An important fact to notice is that the neutralizing condenser NC can never suppress this parasitic oscillation; in fact, its presence makes an even better path for feedback currents.

Low-frequency parasitics can be stopped if either of the chokes is omitted. Sometimes changing the inductance values of the chokes, thus preventing the plate circuit from becoming inductive, will be equally effective. In some cases it is necessary to shunt one or both chokes with moderately high resistance so that parasitics will be damped out by loading.

Ultra-High-Frequency Parasitics. Parasitics occurring at extremely high frequencies are usually caused by the leads to the grid and plate circuits acting as one-turn inductances.

For ultra-high frequencies, the reactance of the tank condensers C₁ and C₂ in Fig. 27A will be negligible. We can, therefore, redraw the circuit to look like Fig. 27C. The heavy, black lines are the leads to the original tank circuits, and it is apparent that in conjunction with the tube capacities they form a u.h.f. tuned-plate-tuned-grid oscillator. The long lead to the neutralizing condenser NC ordinarily has such high impedance at these frequencies that it does not enter into the picture.

The circuit in Fig. 27C will not oscillate unless the plate circuit is tuned to very nearly the same frequency as the grid and is slightly inductive. An obvious way to eliminate u.h.f. parasitics, therefore, is either to increase or to decrease the length of the leads to one of the tank circuits in Fig. 27A so that plate and grid circuit resonant frequencies will be far apart.

Another method is to insert a small "suppressor" resistor of approximately 100 ohms in series with the grid lead as at point A in Fig. 27A. This resistor acts to absorb u.h.f. energy so that parasitics will be damped out. A better method makes use of a small r.f. choke at point A. This choke should be quite small, usually only half a dozen turns, so that its reactance is negligible at the operating frequency.

Testing for Parasitics. In practical cases, after it has been properly neutralized, any output stage such as that in Fig. 27A can be tested for parasitics as follows:

All bias, plate, and filament voltages are applied, but the excitation from the driver is removed. Under these conditions the plate current should be zero. The C bias then is gradually reduced until a moderate amount of plate current flows. Without excitation, there should be no r.f. current whatsoever flowing in the output tank circuit. A flashlight bulb with small pick-up coil when coupled to the tank will glow if parasitics are present. Some other form of indicator can be used for this purpose if desired. Even a neon tube can be used, for it will light when touched to the plate of a tube generating parasitics.

An alternative method is to reduce the C bias to zero so that some grid

current will flow, and to use only a small amount of plate voltage to keep the plate current from being excessive. If the plate tank condenser C₂ then is varied, there should be no change or dip in the grid current indicated on milliammeter MA₁.

In some cases, parasitics are not started until the amplifier is subjected to a sudden voltage surge. It is advisable, therefore, in carrying out tests for parasitics to snap the plate voltage off and on momentarily.

ADJUSTING OUTPUT STAGES

The tuning and adjustment of class C stages has been discussed in an earlier Lesson concerning r.f. amplifiers. The most important principles will be repeated here briefly.

The first step in putting an output stage such as Fig. 27A "on the air" is to neutralize the circuit properly. The C bias and filament voltages are first applied, but the plate voltage is removed. Excitation from the driver is then supplied, and the grid tank condenser C₁ is adjusted for a maximum grid current through MA₁.

By means of a neutralizing indicator, flashlight bulb with pick-up loop, or a neon tube, the output tank is next "probed" to see if any r.f. power is present. If so, then the neutralizing condenser NC is adjusted until the neutralizing indicator reading drops to zero. Tank condenser C₂ next should be rotated to make sure neutralizing is complete for all settings. When the stage is perfectly neutralized, changing the capacity of C₂ will have no effect on the grid current through MA₁.

After neutralizing, the stage is put into operation as follows: With no

plate voltage, but filament and C-bias voltages normal, excitation from the driver is adjusted until the grid current through MA₁ is near the recommended value. Grid tank condenser C₁, of course, should be adjusted for a maximum reading. If the proper grid current is not known, it is usually safe to assume it will be about one-tenth that of the maximum plate current.

With coupling between the output tank coil L₂ and the antenna coil L₃ very small so that no load will be applied to the stage, the plate voltage next is applied, and the tank condenser C₂ is *very quickly* tuned to resonance as indicated by a sharp dip in plate current through MA₂. If the amplifier is being adjusted for the first time, it is usually advisable to use a very low plate voltage so that excessive current cannot damage the tube. After resonance has been established, then full plate-supply voltage can be applied.

Coupling between the output tank and antenna coils next is increased slightly, and the antenna tuning condenser C₃ is adjusted for a *maximum* reading, both on the plate milliammeter MA₂ and the r.f. ammeter MA₃. This will upset the tuning of the tank circuit, and condenser C₂ will need readjustment for a *minimum* plate current, which will be somewhat higher than before because of loading.

Coupling to the antenna is increased gradually in steps—the condenser C₂ being tuned for a *minimum* plate current, and the condenser C₃ being adjusted for a *maximum* plate current each time—until the r.f. ammeter MA₃ indicates normal power output, and MA₂ shows the recommended plate current.

At this point, it is advisable to check the setting of the grid condenser C_1 , re-adjusting it if necessary for maximum drive as indicated by maximum grid current indication.

If it is not possible to make the amplifier draw its full rated plate current, then the excitation from the driver

should be increased. On the other hand, if grid current drawn by the output stage is excessive, excitation should be reduced.

For most efficient operation, the grid current should be kept as low as possible consistent with satisfactory power output.

Lesson Questions

Be sure to number your Answer Sheet 19RC.

Place your Student Number on every Answer Sheet.

Most students want to know their grade as soon as possible, so they mail their set of answers immediately. Others, knowing they will finish the next Lesson within a few days, send in two sets of answers at a time. Either practice is acceptable to us. However, don't hold your answers too long; you may lose them. Don't hold answers to send in more than two sets at a time or you may run out of Lessons before new ones can reach you.

1. Suppose that a class C buffer stage has a power gain of 12. What is the buffer reduction factor (the ratio of grid-impedance change to plate-impedance change)?
2. Why is the master oscillator supplied power from a source independent of other circuits?
3. If a 5.7 mc. master oscillator is followed by one tripler and two doubler stages, what is the output frequency of the transmitter?
4. For a tripler circuit, is the operating angle: 1) *the same as*; 2) *less than*; or 3) *greater* than the operating angle for a doubler?
5. What form of *triode* r.f. amplifier requires no neutralizing?
6. In a class C output stage, what three things prevent the use of a tank circuit with a very *high Q*?
7. What value of *loaded* tank-circuit Q is normally used for a single-tube class C output stage?
8. Besides more power output, what other important advantage is obtained by operating class C output amplifiers in push-pull?
9. What circuit parts are usually responsible for low-frequency parasitic oscillation?
10. If a class C output amplifier should generate ultra-high-frequency parasitic oscillations, how would you suppress them?

Be sure to fill out a Lesson Label and send it along with your answers.

TAKE THE MIDDLE COURSE

Most of us realize the necessity for moderation in eating and drinking, but we often overlook the fact that moderation in all things is essential to happiness.

Consider, for example, the simple matter of opinions. If a man can see only his own opinions, and is unwilling to recognize that other people may also have good ideas, he is *opinionated*. A man with this fault is often unhappy, because he doesn't get along very well with other people. On the other hand, if a man yields his ideas to another's too readily, he is *weak-kneed*—and also unhappy.

If you can give and take—if you are open to reason—if you steer a *middle course*, you will be liked, people will be comfortable in your company, and you will be following one rule of happiness.

In your dress, be neat but not flashy. In your association with people, be courteous, but not affectedly polite. Be sympathetic, but not sentimental. Be self-confident, but don't be led into difficult situations by overconfidence. Don't believe everything you hear but don't think everything you hear is false.

Let "moderation in all things" be one of the guiding principles of your life.

J. E. SMITH