

**HOW TUNED CIRCUITS
FUNCTION**

COUPLING RADIO CIRCUITS

9FR-3

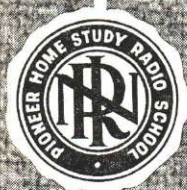

NATIONAL RADIO INSTITUTE

WASHINGTON, D. C.

ESTABLISHED 1914

Study Schedule No. 9

For each study step, read the assigned pages first at your usual speed. Reread slowly one or more times. Finish with one quick reading to fix the important facts firmly in your mind, then answer the Lesson Questions for that step. Study each other step in this same way.

- 1. Introducing Resonant Circuits Pages 1-2
This short section introduces the L-C circuit, and tells how it is different from the filter circuits you have studied so far.
- 2. Series Resonant Circuits Pages 3-9
By comparison with familiar circuits, you are shown how a resonant circuit of the series type functions. Here is a remarkable circuit, capable of stepping up voltage, due to the cancellation effects produced by phase. Study and reread this section. Be sure you understand how the series resonant circuit works before going on, as you will find this information valuable when you study r.f. circuits. Answer Lesson Questions 1, 2 and 3.
- 3. Parallel Resonant Circuits Pages 10-14
The simple act of putting the coil and condenser in parallel instead of in series gives a completely different circuit action. Yet, both circuits will accept or reject signals if properly used. Answer Lesson Questions 4 and 5.
- 4. Practical Resonant Circuit Facts Pages 14-19
The resistance within a resonant circuit has much to do with its ability to select, as you learn from the section on the Q factor. There are also sections giving practical ways of distinguishing series and parallel circuits, and on tuning these circuits. Answer Lesson Questions 6 and 7.
- 5. How Resonant Circuits are Used Pages 19-23
More practical data—showing typical methods of putting resonance circuits to use selecting or rejecting signals. Answer Lesson Question 8.
- 6. Coupling Radio Circuits Pages 24-28
There are four ways of connecting a voltage source to a resonant circuit. These methods of coupling and an introduction to inductive coupling are given here, again from the practical "how it works" angle. Answer Lesson Questions 9 and 10.
- 7. Mail Your Answers for this Lesson to N.R.I. for grading.
- 8. Start Studying the Next Lesson.

HOW TUNED CIRCUITS FUNCTION COUPLING RADIO CIRCUITS

Introducing Resonant Circuits

SEPARATING different frequencies which have become mixed is an important task in radio. An antenna picks up signals from many different stations and we want to pick out just one of these. Within the radio, we have cases where we prevent hum, correct the tone quality and do other desirable things by making the proper separation. As you learned in a previous lesson, coils and condensers can be used

for this purpose. If we want to pass on to the load only frequencies *below* a certain value, we can use a coil *between* the source and load, or we can use a condenser in parallel with the load. To make the cut-off more sharp, we may use both.

Similarly, if we wish to pass on to the load only frequencies *above* a certain value, we merely reverse the connections. This time, we use a con-



Courtesy General Electric Co.

Resonant circuits are used to select the desired station from among all others which are broadcasting. When you tune a radio, you are varying either the L or the C of these circuits to make their reactances balance at the desired frequency.

denser between the source and load; we use a coil in parallel with the load; or use both.

These circuits are known as filter circuits — called *high-pass* filters if they allow only frequencies above a certain cut-off frequency to pass, and called *low-pass* filters if they allow only frequencies below the cut-off frequency to pass.

► Notice that these circuits use only a *single* coil or a *single* condenser, or else they use one in series and the other in parallel with the load. There is *another combination* of a coil and condenser in which *both* are used together. This combination acts in a different manner altogether, forming the basis for new groups of filters.

► As you will soon see, there are many instances where we do not want *all* the frequencies above a certain value, or *all* the frequencies below a certain value. Instead, we may want to pass a certain narrow *band* of frequencies and exclude *all others above or below* this particular frequency range. Or, we may want to *reject* a narrow band of frequencies, yet pass all others *above and below* this narrow band. We can get these actions by: 1, using a coil-and-condenser combination between the load and the source; 2, using the proper combination in parallel with the load; or 3, using the proper combination *as* the load. This combination is known as an “L-C” circuit (L is the symbol for inductance; C is the symbol for capacitance).

► This particular action occurs because of the manner in which the reactances of these parts vary with the frequency. As you know, an increase in frequency causes a higher inductive reactance, while the same increase in frequency causes a lower

capacitive reactance. In other words, if we increase the frequency applied to a coil-condenser combination, the reactance of the coil will increase while the reactance of the condenser will decrease. *Hence, with any coil-and-condenser combination, there is some frequency at which the two reactances are exactly equal*, as will be shown in this lesson. A very special action occurs at this frequency.

By choosing different coil and condenser values, we can “move” this action to a different frequency. This makes it possible for us to “tune” a radio receiver (by using variable coils or condensers) so that we can select the desired signals and exclude signals from other stations operating on other frequencies. *The L-C circuit used for frequency selection is called a tuned circuit or a resonant circuit.*

► Another important use for this characteristic of a resonant circuit is in the generation of radio waves. The fact that this particular combination of parts can be made to accept some one frequency and exclude others makes it possible to use this combination with vacuum tubes in such a way that radio frequency waves of a desired frequency are generated. Thus, the L-C circuit can be used in transmitters and in oscillators to *produce* any desired frequency, while other L-C circuits can be used to accept or reject a particular frequency from among many others.

► Before we can see how L-C circuits are used for these purposes, we must learn how they may be connected together and how they act at resonance. Therefore, in this lesson we will show first how the two main types of resonant circuits function, then discuss some of the ways in which they are used in radio.

Series Resonant Circuits

There are two distinct types of resonant circuits, each having its own peculiar behavior. In a *series resonant circuit*, the source of voltage, the coil, and the condenser are all *in series*. In a *parallel resonant circuit*, the source of voltage, the coil, and the condenser are all *in parallel*. We will consider series resonant circuits first.

► The easiest way for you to understand the important actions that take place in a series resonant circuit is to analyze several circuits in turn. We'll start with a circuit composed of an a.c. generator and a variable resistance; then we'll add an inductance; next, substitute a capacitance for the inductance; and finally, combine the inductance, capacitance, and resistance into a resonant circuit. At each step, we'll see what current flows in the circuit and what voltages exist. This step-by-step procedure will show you exactly what effect each circuit element has on a resonant circuit.

For our explanation, we'll assume that the a.c. generator in the circuit produces 110 volts with a frequency of 500 cycles. This frequency is chosen purely for convenience, because it allows us to form a resonant circuit with inductance and capacity values which are easy to handle in calculations. Actually, any frequency—even r.f.—could be used and would show us the same fundamental facts, if the parts values were properly chosen.

The Resistance Circuit. Fig. 1A shows a circuit with which you're already familiar. It is made up of a variable resistor—value set at 120 ohms—in series with the a.c. source. An ammeter is put in the circuit, and a voltmeter is placed across the resistor to show the current and voltage that exist in the circuit. As you

already know, all the source voltage will be developed across the resistance, so the voltmeter reads 110 volts. And Ohm's Law for this circuit tells us the current flowing will equal the voltage divided by the resistance, so our ammeter reads .92 ampere (actually .917 as it is $110 \div 120$, but the meter *reading* will be so close to .92 that we would accept this as our reading. Other similar *practical* values are used in this lesson.) You learned from your previous lessons that this current is in phase with the voltage.

The Resistance-Inductance Circuit. Now, suppose we add a 100-millihenry (mh.) coil in series with the resistance; this will give us the circuit shown in Fig. 1B. The ammeter now shows a current flow of about .33 ampere. The reason for the decrease in current is that we have added the reactance of the coil to the circuit.

The voltage developed across the coil is shown by a meter to be 103 volts, while that across the resistance

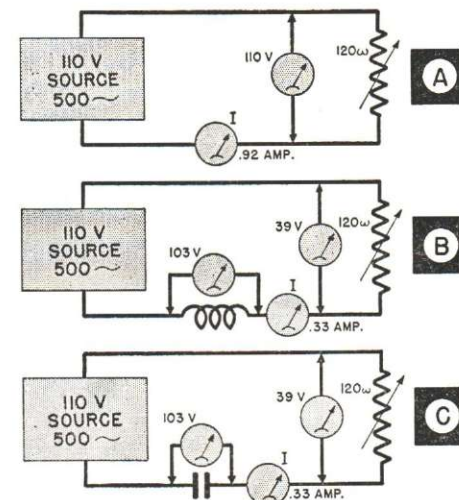

FIG. 1. When either a coil or a condenser is used in series with a resistor, the circuit current is reduced, as we would expect.

is 39 volts—a total of 142 volts, which is considerably more than the 110 volts generated by the source. As you learned in your lesson on coils, *phase* causes this effect. The voltage across the coil is out of phase with the circuit current (the voltage *leads* the current by 90°), while the voltage across the resistor is in phase with the current.

The Capacitance-Resistance Circuit. Now, let's replace the 100-mh. coil with a 1-mfd. condenser as in Fig. 1C. At 500 cycles, the reactance of a condenser of this size is approximately the same ohmic value as that of the 100-mh. coil. (If you wish, you can check this fact by figuring the reactances of the coil and of the condenser by the methods given in earlier lessons.) We see at once that this is true when we measure the current and voltages in the circuit. The voltage across the condenser is 103 volts, and that across the resistor is 39—a total of 142 volts, exactly what we found in the resistance-inductance circuit. And the current is again .33 ampere.

As you know from your study of condensers, the voltage across the condenser is *out of phase* with the circuit current (the voltage *lags* the current by 90°) while the resistor voltage is in phase with the current.

THE RESONANT CIRCUIT

So far, the actions of the components of the three circuits we've analyzed have been familiar. If we combine the three parts, then, we will have a circuit with a condenser, a coil, and a resistor all in series with an a.c. source, and you might expect the current to decrease further.

But—something unusual happens! The voltages and the circuit current increase tremendously when compared with the values of Figs. 1B and 1C. As Fig. 2 shows, a current of .91

ampere flows, and the voltage across the resistor rises to 109 volts. These values are almost what they were in the simple resistance circuit shown in Fig. 1A. Evidently, as far as the resistor voltage and the circuit current are concerned, the coil and the condenser might as well not be in the circuit.

► See what happens to the condenser and the coil voltages! Both increase to 285 volts—well over *twice* the source voltage. The circuit current has increased to almost three times what it was in the circuits shown in Figs. 1B and 1C. As we would expect, the voltage drop caused by this current flow through the coil and condenser reactances has also increased almost three times—from 103 volts to 285 volts. Just what makes this increase possible?

There is a very simple reason for these increases. The condenser voltage is 90° *behind* the circuit current, and the coil voltage is 90° *ahead* of the circuit current. Therefore, the two voltages are 180° out of phase with each other, which means their effects are exactly opposite. And, since the voltages are equal in size and opposite in effect, they cancel one another completely so far as the *circuit* is concerned. A voltmeter placed between points X and Y in Fig. 2 would show no voltage. (That is,

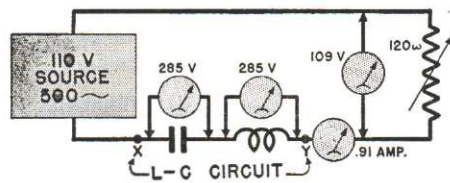

FIG. 2. When both the coil and the condenser are connected in series and are resonant to the applied frequency, their reactances effectively disappear. The circuit current is now determined by the source voltage and the resistance. The voltage drops across both the coil and the condenser are large, and their values are the product of the circuit current multiplied by the respective reactances.

it would if the coil were a perfect inductance, without resistance. But any practical coil has a certain amount of resistance, which will cause a slight extra voltage drop across the coil that the condenser voltage will not cancel. This is the reason why the full source voltage does not appear across the resistor in Fig. 2—one volt has been dropped in the coil resistance.)

This canceling effect of the voltages across the coil and the condenser is always present to some extent in a series L-C circuit, whether or not resonance exists. That is, even when the coil and the condenser reactances are not equal, some cancellation will occur. If the condenser voltage is smaller than the coil voltage, it will cancel a part of the coil voltage, and so cause a slight increase in circuit current over that which would flow if the coil were used alone. The same condition holds if the coil voltage is smaller than the condenser voltage. But the canceling effect becomes extremely noticeable only when the coil and the condenser reactances are equal for the particular frequency fed into the circuit—that is, when the circuit is at resonance. Then we get the enormous increase in circuit current we found in the circuit of Fig. 2, where practically all that limits the current is the resistor.

Reducing R. Fig. 3 shows what happens if we reduce the size of the resistor in our resonant circuit. Here, the electrical sizes of the circuit components are the same as in Fig. 2, except that the ohmic value of the resistor is reduced from 120 to 50 ohms. The circuit current increases to 2.1 amperes—and the condenser and the coil voltages (the result of this current flow through their impedances) jump to 670 volts! This shows that the value of the resistance in a resonant circuit is very important in

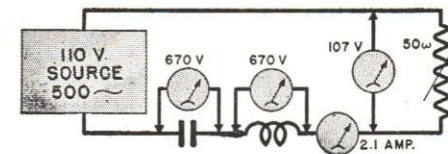

FIG. 3. The voltages measured here prove that the circuit current in a resonant circuit depends only on the circuit resistance.

determining the amount of current flowing. Notice, however, that less voltage appears across the resistor in the circuit of Fig. 3 than was across it in Fig. 2—107 volts for the former as against 109 volts for the latter. This difference is caused by the increased voltage drop across the resistance of the coil when the current is increased.

We cannot, therefore, produce an almost infinite current or an almost infinite voltage across the coil or across the condenser by reducing resistor *R* to zero. The resistance of the coil will limit the current flow, even if there is no other resistance in the circuit. However, if we used a coil with very low resistance and carefully removed as much resistance as possible from the remainder of the circuit, we could get a very high current in our resonant circuit (and so a very high voltage across the coil and across the condenser). Of course, in practice, the source voltage usually will range from a small fraction of a volt to just a few volts, so even at best the condenser or the coil voltage is small. However, in such a circuit, it is sometimes necessary to limit the source voltage so the current will not rise to such values that the condenser voltage ratings are exceeded.

Resonant Voltage Step-Up. One of the most useful effects in a series resonant circuit is the fact that a high voltage—much higher than the source voltage—can exist across the coil and across the condenser at the resonant frequency of the combination. This

is called *resonant voltage step-up*. By connecting across either the coil or the condenser (but not across both), we can use the voltage across that part to operate another circuit. The resonant circuit in effect has "amplified" the signal to which it is tuned, but will not so treat other frequencies. Hence, the circuit "selects" particular frequencies by increasing these more than others. You will meet and use this effect constantly in your later work in radio.

Conditions in a Series Resonant Circuit. Let's repeat the substance of what you've just learned, so it will be firmly fixed in your mind. In a series resonant circuit *at resonance* we have:

1. Maximum circuit current, determined by the resistance in the circuit and the source voltage.

2. Maximum and equal voltages across the coil and across the condenser, determined in size by the circuit current and by their reactances.

3. The L-C part of the circuit (the section between points X and Y in Fig. 2) *acts like a resistor of low ohmic value*; this resistance is almost entirely concentrated in the coil.

► Remember—this condition of series resonance exists for the circuits we've been considering *only at one particular frequency*. We deliberately chose the values of inductance and capacity used so that their reactances would be equal at 500 cycles, the frequency of the source. *Their reactances would not be equal at any other frequency*, so, with the particular condenser and coil we have used, *our circuit cannot be resonant at any other frequency*. In other words, our circuit is *tuned to resonance at 500 cycles*.

VARYING L AND C

Let's see what would happen if we were to use other values of capaci-

tance or inductance in our circuit.

Varying C. Suppose we were to vary the value of C (by inserting condensers of different sizes) while leaving the *source frequency*, the *coil*, and the *resistor* just as they are in Fig. 2. We are particularly interested in the circuit current I , since it determines what the voltage across L or C will be.

Fig. 4 shows a plot of the circuit current I for various values of C . With condensers smaller than 1 mfd., circuit current I drops rapidly; the

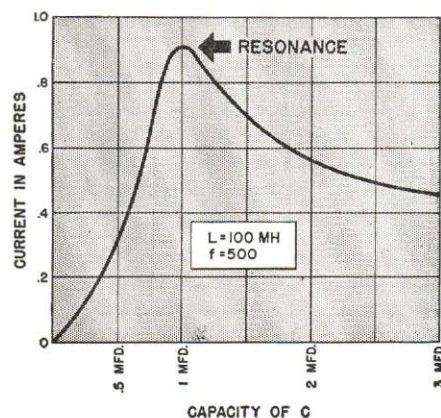

FIG. 4. This graph shows how the current varies in a series resonant circuit when the value of capacity C is varied from 0 to 3 mfd. Note that at 500 cycles and with a 100 mh. coil, resonance and maximum current occur when the capacity of C is 1 mfd., making its capacitive reactance equal to the inductive reactance of L .

smaller the value of C , the lower the current. The reason is quite simple; reducing the electrical value of C increases its reactance above that of L , and that portion of this capacitive reactance which is not cancelled by L acts to limit current flow.

With condensers larger than 1 mfd., the ammeter reading likewise drops; increasing the electrical value of the condenser makes the reactance of C lower than that of L , with the result that a portion of the inductive reactance is left over to limit current flow.

► Incidentally, when we tune our series resonant circuit away from resonance, the circuit will act the same as *that reactance which is the larger or is predominant*. Lowering the value of C here makes the capacitive reactance the larger, and the series resonant circuit therefore acts like a condenser, while increasing C makes its reactance less and the circuit acts like an inductance.

Varying L. If the inductive reactance (instead of capacitive reactance) were varied by inserting various values of L in the series resonant circuit, similar results would be obtained, as it is the amount of reactance left over (not balanced out) which governs the current. This is

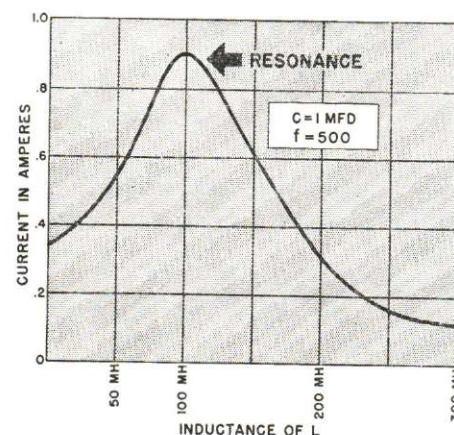

FIG. 5. Varying L instead of C produces this kind of graph. Resonance again is obtained when the coil and condenser reactances are equal.

shown by Fig. 5—a graph of the circuit current for various values of L .

Varying Both L and C. With a 500-cycle source, we know that resonance can be obtained with a 1-mfd. condenser and 100-mh. coil. Could resonance also be obtained at this same frequency with other values of L and C ? Suppose we try using a 50-mh. coil and vary C . If we do, we will find that we get resonance (maxi-

mum current) with a 2-mfd. condenser. Now notice—multiplying together the values of L and C in our original circuit (Fig. 2) gives a figure of 100 (100×1). We get exactly the same figure for a circuit with a 50-mh. coil and a 2-mfd. condenser ($L \times C = 50 \times 2 = 100$). As a matter of fact, we would find, if we tried other values of L and varied C to bring the circuit to resonance at 500 cycles, that multiplying together the values of L in millihenrys and C in microfarads at resonance always will give the number 100 for a 500-cycle source (this figure is sufficiently accurate for practical purposes). The larger the value of L , the smaller will be the value of C required for resonance.

► If we changed the source frequency to, say, 1000 cycles, then changed either L or C until resonance was reached, we would find that the product of L (in millihenrys) multiplied by C (in microfarads) would be 25. At some other frequency, we would find the product of L times C would be equal to some other number; in other words, there is one number corresponding to each resonant frequency. Tables are available giving these numbers for different frequencies, so an engineer who is assembling a resonant circuit need only look up this number for the frequency in question, then choose values of L and C which, when multiplied together, will give this number. (Although this number is equal to L times C , engineers for convenience often omit the word "times" and simply call it the $L-C$ value.)

This relationship between L and C at any resonant frequency makes it easy for engineers to predict beforehand what values of L , C , and frequency will give resonance in a particular circuit. When any two of these values are known, they can find the

third either by means of a chart, a table, or a mathematical formula.*

► We just said that the product of L and C for a circuit resonant at 500 cycles is 100, while L times C for a circuit resonant at 1000 cycles is 25. This is an example of a general rule which you will find useful to remember—the lower the L - C value of a series resonant circuit, the higher the frequency to which the circuit is resonant. In other words, decreasing the value of either L or C increases the

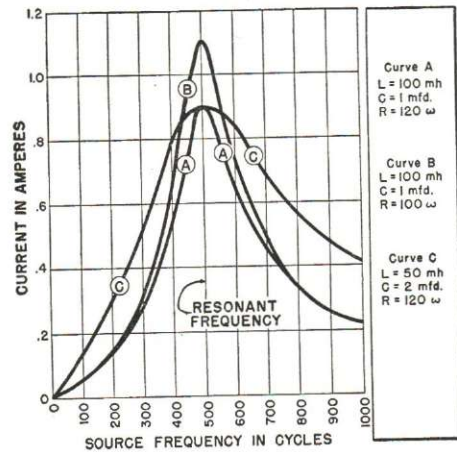

FIG. 6. Here is what happens when you vary the frequency of the source in a series resonant circuit. These curves prove that for any given set of values for L and C , there is only one frequency at which resonance and maximum current will be obtained. Notice that it is possible to obtain resonance with a different value of L and C , providing the L - C product is the same. Also, reducing the circuit resistance (curve B) produces a sharper curve with a higher peak.

resonant frequency of a series resonant circuit, while increasing the value of L or C decreases the resonant frequency.

* For those who are interested in mathematics, this formula is:

$$f = 159,000 \div \sqrt{LC}$$

In this formula, f is the resonant frequency in cycles, L is the inductance of the coil in microhenrys (1 millihenry = 1000 microhenrys) and C is the condenser capacity in microfarads. This formula applies to both series and parallel resonant circuits.

For example, using a 100-mh. coil and a condenser of 2 mfd. does not give resonance at 500 cycles, but does give resonance at the frequency corresponding to an L - C value of 200. As we expect, the new resonant frequency is lower than 500 cycles—it is near 355 cycles. Hence, when we change either the coil or the condenser, we tune away from one frequency but establish resonance at another. Thus, an L - C circuit is always resonant to some frequency, although it may not be the desired frequency.

Resonance Curves. The most important characteristic of a resonant circuit is how much better it accepts the desired resonant frequency than the undesired frequencies on either side. In radio receivers, for example, we want the resonant circuits to tune in a desired carrier frequency signal while rejecting the adjacent undesired carriers. To find how well a resonant circuit can do this, we refer to a curve obtained by plotting current against source frequency. (Such a curve is commonly called a *resonance curve*, because it shows how circuit conditions change as we pass through resonance.) Three such curves for series resonant circuits are shown in Fig. 6; let us see how much they can tell.

► Curve A in Fig. 6 is for the series resonant circuit in Fig. 2; it was obtained by keeping the source voltage constant while varying the frequency and measuring the circuit current. You can see that there is quite a drop in circuit current as you go above and below the resonant frequency of 500 cycles. The sharper the curve at resonance, the greater will be this drop in current or, as radio men say, the better will be the selectivity of the circuit. (Since such a curve shows how selective a circuit is, it is often called a *selectivity curve*.) You will learn later in the course, however,

that a certain amount of broadness in the curve at resonance is also desirable in order to keep distortion at a minimum. Let us see how we can get a more peaked curve, and a broader curve.

► You will recall that the rheostat (R) was set at 120 ohms in Fig. 2; if we change the setting to 100 ohms, the circuit resistance at resonance will be lower and we will secure a more peaked resonance curve. This is evident in Fig. 6 from the fact that curve B for 100 ohms has a higher and sharper peak than curve A for 120 ohms. Lowering the resistance in a series resonant circuit thus improves selectivity, as it allows a higher current at resonance. This means the *resonant step-up* is greater, but the voltages at other frequencies are not stepped up, so the difference between the voltage at resonance and the off-resonance values is greater.

► Suppose we use a 50-mh. coil and a 2-mfd. condenser, resetting R to 120 ohms. We still get resonance at 500 cycles, as the L - C value of 100 has not been changed, but now curve C in Fig. 6 represents conditions in the circuit. Note that this curve is considerably broader at resonance; this indicates that a wider range of frequencies around the resonant value will be passed almost equally well. If we experimented further in this same way, we would find that the lower the value of L , while circuit resistance is kept constant, the broader will be the resonance curve obtained. (Incidentally, resonance or selectivity curves

like those in Fig. 6 are also known as *frequency response curves* or simply as *response curves*.)

Resonance Current and Voltage.

We have pointed out several times that a circuit will be resonant at 500 cycles regardless of what values of L and C we use, provided only that the product of L times C equals 100. The circuit current will be about the same at resonance whether we use a large coil and a small condenser or a smaller coil and a larger condenser. This is because the reactances of L and C cancel at resonance, no matter what their values are, and only the resistance in the circuit limits the current flow.

The voltages across the coil or condenser at resonance, however, will depend upon the values of L and C . If we obtain resonance by using a 50-mh. coil, for instance, the voltage across it will be only about half what it would be across a 100-mh. coil. You can readily see the reason for this—the voltage across the coil is equal to the current times the coil reactance. A 50-mh. coil has only half the reactance of a 100-mh. coil and, since the current remains constant, reducing the coil reactance one-half reduces the voltage across it by one-half. For this reason, in series resonant circuits a high L -to- C ratio is used when the greatest resonance voltage step-up is wanted. (A large inductance and a small capacity are used.) Don't confuse this ratio with the L - C value; the ratio is $L \div C$, while the L - C value is $L \times C$.

Parallel Resonant Circuits

When the source for a resonant circuit is connected in parallel with both the coil and the condenser, as in Fig. 7, we have a *parallel resonant circuit*. The values of L , C , and R used in this circuit are the same as those in the series resonant circuit in Fig. 2, so you might expect that circuit current and voltages would be about the same for Fig. 7 as they are for Fig. 2. But actual measurements would show that they are completely different.

For one thing, the circuit current in Fig. 7 (measured on an a.c. ammeter in series with the generator) is very low. (As you recall, the circuit current in a series resonant circuit is high.) And, practically all the generator voltage appears across the resonant circuit, between terminals X and Y , with almost no voltage across resistance R . This is completely different from the series resonant circuit.

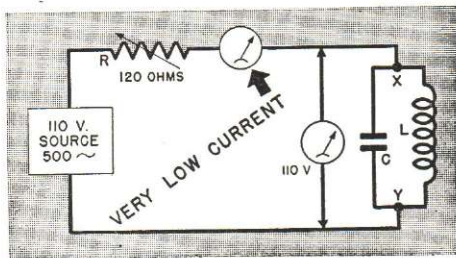

FIG. 7. At resonance, a parallel resonant circuit reduces the line current to a very low value.

In the series circuit, nearly all the generator voltage appears across resistance R , and almost none across the resonant circuit. (Of course, there is always a high voltage across each of the *parts* in the series circuit, but these voltages cancel one another. Across the *whole* L - C circuit, between terminals X and Y in Fig. 2, there is almost no voltage.)

► Suppose we set up a circuit like that in Fig. 8, with a.c. ammeters inserted in the parallel resonant circuit to measure currents I_1 and I_2 through C and L , respectively. We would discover another surprising fact—there is plenty of current inside the parallel circuit itself! I_1 and I_2 are both high, and equal to one another. Yet, outside the parallel circuit, there is practically no current.

► Clearly, this resonant circuit for some reason acts like a very high resistance *across its terminals* (X and Y in Fig. 8), but at the same time offers very little opposition to current flow *in the resonant circuit itself* (the circuit made up of L , C , and the two ammeters). The reason for this peculiar combination of actions is really quite simple. Here, our reference factor is the source voltage which is across both the coil and the condenser. You know that the current flow in a coil is 90° behind the coil voltage, while the condenser current is 90° ahead of the condenser voltage. Since the source voltage is now across both the coil and the condenser, it becomes the coil voltage and the condenser voltage. As one current is ahead 90° and the other is behind 90° , this makes the *currents* 180° out of phase. (Compare this with the series resonant circuit, where the *current* is the reference value and the *voltages* are 180° out of phase.)

The fact that the currents I_1 and I_2 are 180° out of phase means that the condenser discharges during the half cycle in which the coil stores up energy; on the next half cycle, the coil releases energy while the condenser stores it. When the impedances of the coil and the condenser are equal (that is, at resonance) the energy stored by

the condenser equals the energy released by the coil, and vice versa. Then the condenser absorbs all the energy released by the coil, and in turn releases this energy to be absorbed by the coil. Thus the coil and condenser pass current back and forth

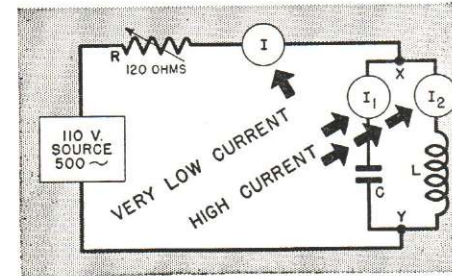

FIG. 8. The current within a parallel resonant circuit is very high, compared to the line current, due to resonance current step-up.

inside the resonant circuit, causing the high readings on the meters in the circuit. The source has to supply only enough power to make up for the small power losses in the small resistances within the coil and the condenser, so the current outside the resonant circuit is small.

► Whenever a coil and a condenser are in parallel in an a.c. circuit (regardless of whether or not their reactances are equal), one will be feeding current back into the line while the other is drawing current. Therefore, the line current at any instant (taking phase into account) will be the difference between the two currents. When the reactances are equal, as at resonance, the line current is a minimum, while both the coil and condenser draw a current determined by their reactances and the voltage across the resonant circuit. At resonance, then, a parallel resonant circuit behaves as a *resistor of high ohmic value*, reducing line current almost to zero. The resistance of a parallel resonant circuit at resonance is known

as the *resonant resistance* of the circuit.

Resonant Current Step-Up. You have just seen that the current through either the coil or the condenser in a parallel resonant circuit is higher than the line current at resonance. This is *resonant current step-up*—the ability of a parallel resonant circuit to circulate a current many times greater than the current fed into it. This particular characteristic is very useful in radio circuits, as you will soon see.

VARYING R , L , C , AND F

Varying the Coil Resistance. Since all coils have a certain amount of resistance acting in series with their inductance, let us see how increases in this resistance affect a parallel resonant circuit. Instead of analyzing circuits using coils with the same inductance and various values of resistance, let us assume a circuit like that in Fig. 9, where we have a rheostat R_1 in series with our coil. If we were to start with R_1 at zero resistance, then increase it gradually, we would find that the coil current goes down only a little, the condenser remains the same, but the line current goes up. This means that when the resistance in series with the coil in a parallel resonant circuit is increased, the *resonant resistance of the L - C cir-*

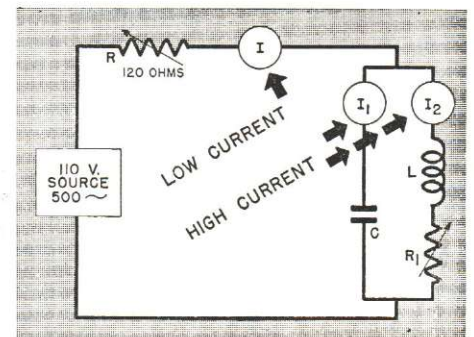

FIG. 9. Resistance within the resonant circuit (R_1) reduces the current step-up.

cuit (between points x and y in Fig. 8) is decreased. This allows more line current to flow, and makes the line current value more nearly equal to the condenser current. We can conclude, then, that inserting resistance in a parallel resonant circuit decreases both the resonant current step-up ratio (the ratio of coil current to line current) and the resonant resistance.

Varying C. With the parallel resonant circuit in Fig. 9 tuned to resonance and both R and R_1 at their zero resistance settings, let us see what effect varying C would have on the line current while the source frequency is kept constant at 500 cycles. Fig. 10, in which the line current is plotted for various values of capacity, shows the result we would get.

Starting with a very small value of capacity for C , we would find that condenser current is practically zero, as it offers a very high reactance. The line current is then determined by the coil reactance (R is set at zero). Hence, the coil and line currents are both about .35 ampere.

As the capacity of C is gradually increased, its reactance decreases, so we would find that the condenser current goes up, line current goes down, and coil current remains unchanged. Coil and condenser currents become more nearly equal as the capacity of C approaches its resonant value. Finally, the condition of resonance is reached, where line current is at its minimum value and the coil and condenser currents are equal.

Increasing the capacity of C above the resonant value causes line current to go up again, while condenser current continues to increase. With a very high capacity for C the reactance of C becomes so low that coil current becomes negligible in comparison with the extremely high condenser current, and meters I and I_1 of Fig.

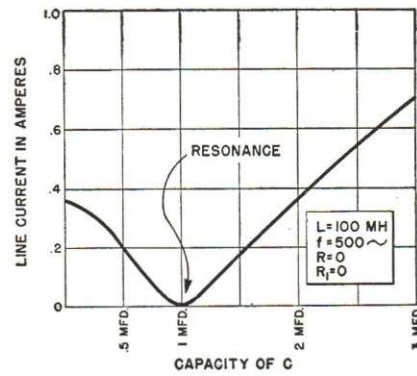

FIG. 10. This graph tells how the line current changes when the capacity of the condenser (C) in a parallel resonant circuit is varied.

9 read almost the same values.

► Lowering the capacity of C below the resonant value (the value giving resonance at the source frequency) makes the reactance of the condenser greater than the reactance of the coil. A parallel resonant circuit acts the same as the part drawing the most current (having the least reactance), so in this case the parallel circuit acts like a coil. On the other hand, raising the capacity of C above the resonant value makes the reactance of the condenser less than that of the coil, so the parallel circuit acts like a condenser.

► Actually, when we reduce or increase the value of C from the resonant value, we make the parallel circuit resonant to some other frequency. The frequency to which the circuit will be resonant with the changed value of C is, of course, the frequency at which the reactance of the coil will equal the reactance of the new value of C . From what you already know about how the reactances of coils and condensers vary with frequency, it will be easy to see that decreasing the value of C raises the frequency to which the circuit is resonant, while increasing the value of C lowers the resonant frequency.

Varying L. If we were to vary inductive reactance (instead of capacitive reactance) by using different sizes of coils for L while keeping the source frequency constant, we would find that low-inductance values of L had the same effect as high-capacity values of C , and high values of L gave the same results as low values of C .

Varying Frequency. Now suppose we see what would happen in the circuit shown in Fig. 9 if we were to set both R and R_1 to zero resistance and vary the frequency of the source without changing its voltage or the coil and condenser values. Suppose we start with a very low frequency (less than one cycle per second). This is very nearly the equivalent of direct current, and you know that C will act as an open circuit (very high reactance), while L will act as a short (very low reactance). This means that a very high current will flow through the coil and ammeters I and I_2 .

Increasing the frequency gradually from zero to 500 cycles makes the reactances of L and C more and more nearly equal, with the parallel resonant circuit acting in the same manner as a coil (because below 500 cycles

the reactance of L is lower than that of C). Line current drops to almost zero at 500 cycles, and condenser current increases gradually, being equal to the coil current at 500 cycles.

► When the source frequency is 500 cycles, we have the resonance condition already described.

► As the source frequency is increased above 500 cycles, coil reactance goes up and condenser reactance goes down, making our parallel resonant circuit behave as a condenser, with line current increasing again to supply the extra current drawn by the condenser. At a very high frequency, the reactance of L will be so high that it will act as an open circuit, but the reactance of C will be practically zero, and line current will be just as high as it was for very low frequencies.

Varying Both L and C. If we were to insert various values of L in Fig. 9 and use the correct values of C to give resonance at 500 cycles, we would find in each case that the same number is obtained by multiplying together the values of L and C . In other words, the product $L-C$ is a constant for a given frequency, just as it was for series resonant circuits. Furthermore, it is the same number as the $L-C$ value for series resonance. Also, the formula for determining the resonant frequency when L and C are known (already given you in a previous footnote) applies to parallel resonant circuits as well as series resonant circuits.

Resonance Curves. We can draw the same kind of resonance curves for our parallel resonant circuit that we draw for the series circuits by plotting frequency against line current, as in Fig. 11—the entire 110 volts is applied, as R is reduced to zero. When L is 100 mh. and C is 1 mfd., curve A is secured, while when L is 10 mh. and C is 10 mfd., curve B is the result. As you can see from these curves,

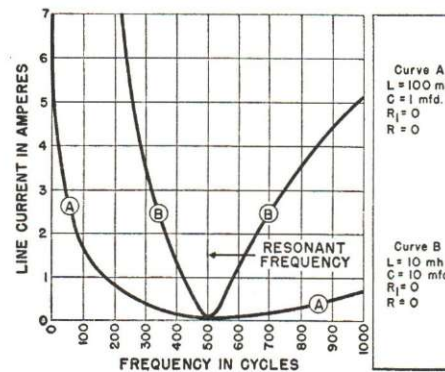

FIG. 11. The effects of variations in frequency on the line current for a parallel resonant circuit are given on this graph for two different L-C ratios.

lower values of L in parallel resonant circuits make line current increase more rapidly off resonance. In other words, a parallel resonant circuit

tunes more sharply if L is small, so a low L -to- C ratio is desirable here. A small inductance and a large condenser are used for greatest selectivity.

Practical Resonant Circuit Facts

Tuned circuits are found most commonly in the r.f. stages of radio apparatus, where they are used to separate signals coming from different stations. This separation is possible when the stations operate on different frequencies, as we will show you later in this lesson by means of typical circuits.

However, there are several points we should clear up before going on to these practical circuits. We should get an idea of the amount of resonance step-up obtainable; learn how to recognize series and parallel circuits; and learn how these circuits may be adjusted or tuned to resonate with different frequencies. We will now take these subjects up in order.

Q FACTOR

You have learned that the resonant voltage step-up or resonant current step-up of any resonant circuit increases as the resistance in the circuit is decreased. Since a high step-up ratio usually is wanted, engineers seldom insert resistors intentionally in resonant circuits. However, any resonant circuit has a certain amount of loss caused by the effective a.c. resistances of the coil, the condenser, and the wiring in the circuit. Usually we can assume this loss is concentrated in the coil. And we can see what effect such a loss has on a circuit by using a quantity called the "Q factor" of the coil.

The Q factor is really a measure of

the merit of the coil. It can be computed for any coil from the formula $Q = X_L \div R$, where R is the total a.c. resistance of the coil, and X_L is the inductive reactance of the coil. (Test instruments are available which will measure the Q of a coil.) As practically all the loss in a resonant circuit is concentrated in the coil, we usually assume that the coil Q is also the Q of a resonant circuit using that coil. This factor applies to both series and parallel resonant circuits.

► Of what use is the Q factor to us in our study of resonant circuits? For one thing, it allows us to compare two coils of the same inductance to see which has the more desirable characteristics for use in a tuned circuit. If two coils have the same inductance, but the Q factor of one is higher than the other, we know at once that the coil with the higher Q will give sharper tuning (better selectivity) in a resonant circuit. (This follows from what you have already learned. You know that a circuit tunes more sharply if the resistance in it is small, and from the formula just given, it is obvious that if two coils have the same inductance, the coil with the higher Q factor will have the smaller resistance.)

Also, a knowledge of the Q factor of the coil used in a resonant circuit will let us find out several things about the circuit itself. In a series resonant circuit, the applied voltage multiplied by the Q gives the voltage

available across either the coil or the condenser. In a parallel resonant circuit, the line current multiplied by Q gives the current flowing in the tuned circuit; also, multiplying Q by the coil reactance will give us the resonant resistance of the parallel resonant circuit.

► Notice—we used the a.c. resistance of the coil in our formula for Q factor. This is not the same amount as the d.c. resistance of the coil, which we could measure with an ohmmeter. The a.c. resistance of a coil is always much higher than the d.c. resistance, particularly when the coil is used in r.f. circuits. This is because r.f. current does not travel through the entire cross-section of the wire in a coil, but instead tends to travel close to the wire surface. The tendency becomes more marked as the frequency of the current is increased. This is known as the "skin effect."

The skin effect means that the actual current-carrying area of the wire in a coil is considerably reduced as the frequency of the current increases, and therefore the resistance of the coil increases. To this resistance must be added dielectric losses in the coil form, shield losses, and, in a coil which has an iron core, losses in the core. All these factors make up the a.c. resistance of the coil as they represent losses. This resistance has all the characteristics of resistance, and must not be confused with reactance, which the coil also has. Engineers frequently draw a resistance symbol in series with the coil symbol to indicate that the coil resistance is in series with the inductance.

Since both the a.c. resistance and the inductive reactance increase as the frequency of the circuit current increases, it might seem as if these increases would cancel one another, so that the Q factor of the coil (the ratio

of the reactance to the a.c. resistance) would remain constant for all frequencies. In the interest of greater operating efficiency, many coil designers try to achieve this effect. Usually, however, the a.c. resistance of a coil increases much more rapidly than does the coil reactance as the frequency of the circuit current is raised. Therefore, it is generally true that the Q factor of a coil becomes smaller when higher frequency currents flow through it. In recognition of this fact, the Q factor of a coil always is specified as having been measured at some particular frequency.

COMPARING RESONANT CIRCUITS

A comparison of series and parallel resonant circuits is given elsewhere in this lesson, in a table. Here are a few additional facts:

► When a resonant circuit is designed for a particular frequency, inductance and capacity values are chosen which will give the $L \times C$ value necessary at that frequency. However, we often want a resonant circuit which can be tuned over a band of frequencies at will. For example, the r.f. circuits of your radio tune over the broadcast band, covering frequencies from 550 kc. to 1500 or 1600 kc. In these cases, the maximum inductance or capacity value of the variable part is found, then the circuit is designed to tune to the lowest frequency in the band. Then, as the variable capacity or variable inductance value is decreased, the circuit tunes to higher frequencies and thus is made to cover the desired band. In this case, notice that there are a number of frequencies applied simultaneously, and the resonant circuit is adjusted to "tune in" or accept the one in which we are interested.

► When a choice of several L and C values is possible and maximum selec-

Comparison of Series and Parallel Resonant Circuits

SERIES RESONANT CIRCUITS

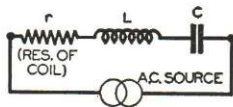

1. The coil, the condenser and the A.C. voltage source are all in series.
2. Resonance occurs when the reactance of L is equal to the reactance of C .
3. At resonance, source current is a *maximum* (very high).
4. At resonance, a series resonant circuit acts like a *resistor of low ohmic value*.
5. At resonance, the voltages across L and C are equal in magnitude but 180 degrees out of phase with each other.
6. At resonance, the same current flows through the entire circuit.
7. At resonance, the voltage across either L or C may be greater than that of the source, giving resonant voltage step-up.
8. At resonance, increasing the value of coil resistance r lowers the circuit current, thereby *lowering* the resonant voltage step-up.
9. Off resonance, the circuit acts like that part which has the *higher* reactance.
 - a. Increasing C above its at-resonance value makes the circuit act like a coil.
 - b. Reducing C below its at-resonance value makes the circuit act like a condenser.
 - c. Increasing L above its at-resonance value makes the circuit act like a coil.
 - d. Reducing L below its at-resonance value makes the circuit act like a condenser.
 - e. Applying a *higher* frequency than the resonant one makes the circuit act like a coil.
 - f. Applying a *lower* frequency than the resonant one makes the circuit act like a condenser.
10. The product LC is constant for any given resonant frequency.
11. Increasing L or increasing C lowers the resonant frequency.
12. Decreasing L or decreasing C raises the resonant frequency.
13. The Q factor of the circuit is essentially equal to the coil reactance divided by the A.C. resistance of the coil.

PARALLEL RESONANT CIRCUITS

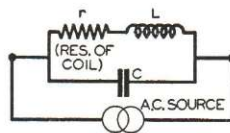

1. The coil, the condenser and the A.C. voltage source are all in parallel.
2. Resonance occurs when the reactance of L is equal to the reactance of C .
3. At resonance, source current is a *minimum* (very low).
4. At resonance, a parallel resonant circuit acts like a *resistor of high ohmic value*.
5. At resonance, the voltages across L , C and the source are all the same in magnitude and phase.
6. At resonance, the currents through L and C are essentially equal in magnitude but are 180 degrees out of phase.
7. At resonance, the current through either L or C is greater than the source current, giving resonant current step-up.
8. At resonance, increasing the value of coil resistance r increases line current, thereby *lowering* the resonant current step-up.
9. Off resonance, the circuit acts like that part which has the *lower* reactance.
 - a. Increasing C above its at-resonance value makes the circuit act like a condenser.
 - b. Reducing C below its at-resonance value makes the circuit act like a coil.
 - c. Increasing L above its at-resonance value makes the circuit act like a condenser.
 - d. Reducing L below its at-resonance value makes the circuit act like a coil.
 - e. Applying a *higher* frequency than the resonant one makes the circuit act like a condenser.
 - f. Applying a *lower* frequency than the resonant one makes the circuit act like a coil.
10. The product LC is constant for any given resonant frequency.
11. Increasing L or increasing C lowers the resonant frequency.
12. Decreasing L or decreasing C raises the resonant frequency.
13. The Q factor of the circuit is essentially equal to the coil reactance divided by the A.C. resistance of the coil.

tivity is desired:

- A. For series resonance, use a large inductance and small capacity, giving a high $L \div C$ ratio.
- B. For parallel resonance, use a small inductance and large capacity, giving a low $L \div C$ ratio.

► After the L and C values have been chosen, the Q factor then determines the actual voltage or current step-up. The higher the Q (the lower the a.c. resistance), the greater the step-up.

Distinguishing Between Series and Parallel Resonant Circuits. One question often asked even by experienced radio men is, "How can I tell whether a resonant circuit is of the series or parallel type when I see it in a circuit diagram or in radio apparatus?" It's not really very difficult. Here's a simple procedure that will give you the right answer every time:

1. Locate the coil and the condenser forming the resonant circuit.
2. Locate the source of a.c. voltage for this resonant circuit. Typical sources will be receiving antennas, plate circuits of vacuum tubes, and voltages induced from other circuits.
3. If the source for the resonant circuit is *in series* with the coil and the condenser, you have a series resonant circuit.
4. If the source for the resonant circuit is connected *directly in parallel with both* the coil and the condenser, you have a parallel resonant circuit.

VARIABLE INDUCTANCES

You know that a circuit can be tuned by varying either the capacity of the condenser or the inductance of the coil, but how do we actually vary these things? You know the answer as far as variable condensers are concerned, since they have been fully covered in another lesson. Variable inductances were mentioned

in a previous lesson, but now let's spend a little time learning more about how variable inductances work, because inductance tuning is becoming increasingly more important in modern radio receivers. (It has been used in transmitters for years.)

You will recall that anything which increases or decreases the magnetic flux linkage per ampere of current flowing through a coil will increase or decrease the inductance of the coil. For example, increasing the number of turns on the coil increases its inductance, and increasing the amount of flux flowing through the coil like-

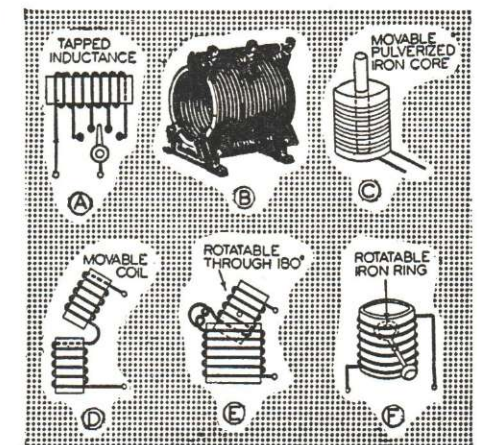

FIG. 12. Methods of varying the inductance of a coil.

wise increases its inductance. One way of building a variable inductance, then, is to use a coil which has the number of turns required to give the maximum desired inductance for a circuit, and provide some means of using fewer turns when we want to reduce the inductance in the circuit. One scheme which has been widely used for this purpose is shown in Fig. 12A. Here, various turns on the coil are connected by means of wire leads (taps) to metal contacts over which a contact arm moves, thus permitting

the operator to select as many or as few turns as he requires.

Earlier radio receivers used this tapped inductance extensively, while a variation of it is still being used in transmitters. Fig. 12B shows a transmitting coil with movable clamp type contacts which can be placed on any desired turns. Only those turns which carry current are effective in producing flux linkages.

► You can increase flux through a coil and thereby increase its inductance by placing inside the coil a material which offers less opposition than air to the flow of magnetic lines of force.

For low frequencies, iron and steel in either solid or laminated (thin sheets in layers) form make satisfactory coil cores, but for radio frequencies, solid or laminated cores act as a multitude of tiny short-circuited secondary coils which serve to reduce the useful magnetic flux. Radio manufacturers get around this difficulty by pulverizing the steel core material and mixing this steel powder with liquid bakelite (a good insulator). The resulting mixture can be molded into a core of the desired shape for use with radio frequency coils. The metal particles are insulated from each other by the bakelite and so do not produce the short-circuiting effect just mentioned. However, enough iron is in the mixture to reduce the reluctance of the magnetic field and thus to increase the inductance. If the core is designed so that it can be moved in and out of the coil, as indicated in Fig. 12C, we have another form of variable inductance. This style of inductance variation is used most commonly today in radio receivers.

► Two coils are often connected together in series. If the coils are some distance apart, so that there is no

coupling between them, their combined inductance is the sum of the separate inductances. As the coils are moved closer to each other, so that the flux of one links the turns of the other, the combined inductance will increase if the two fluxes are in the same direction and will decrease if the two fluxes are in opposite directions. A variable inductance of this type is illustrated in Fig. 12D.

A more convenient way of using the combined inductance of two coils to produce a variable inductance is shown in Fig. 12E. Here, one of the coils is made smaller and mounted on a shaft inside the other. It is possible, by rotating the inner coil, to vary the combined inductance of these coils over a wide range. When the coils are arranged so that their currents flow in the same direction, the fluxes will be in the same direction and the combined inductance will be high. When the inner coil is turned halfway around (180°) so that the currents flow in opposite directions, the fluxes will oppose each other and the inductance will be greatly reduced. A variable inductance of this type is known as a *variometer*.

► Another method of constructing a variable inductance is illustrated in Fig. 12F. A rotatable metal ring is mounted in the center of the core; when this ring is at right angles to the axis of the coil, it acts as a short-circuited secondary winding having one turn. The induced voltage causes a high current in this secondary, which in turn produces a flux which partially balances out the coil flux, reducing the inductance of the coil. Rotating the ring lessens the amount of flux which can induce a voltage in the ring. This reduces the "bucking" effect of the flux produced by the ring and increases the coil inductance. A metal disc will work equally as well as a

ring in this variable inductance, for a disc really consists of a great many rings, one inside the other. A very important fact to remember is that the presence of any conducting material near a coil, such as a metal shield surrounding a coil, will reduce the inductance.

► Of course, a fixed condenser is used in the tuned circuit when the inductance is variable, while a fixed induct-

ance is used with a variable condenser for any one tuning range. Where several ranges are to be covered, as in a receiver designed to tune over short-wave bands as well as the broadcast band, tapped coils (or separate coils, exchanged by a switch) usually are used for the extra bands. You will learn more about this when you study r.f. stages and all-wave receivers.

How Resonant Circuits Are Used

Now, since you have learned how resonant circuits function, let us put both the series and the parallel circuits to use in practical radio applications.

WAVE TRAPS

Using a Parallel Resonant Circuit. When a radio receiver is located so near a powerful short-wave or broadcast band transmitter that signals from this station interfere with those of stations broadcasting on adjacent frequencies, a wave trap similar to that shown in Fig. 13A is quite often used. The wave trap weakens the signal of the undesired local station before this signal gets into the amplifying section of the receiver. A parallel resonant circuit made up of coil L and condenser C is inserted in the antenna lead-in wire and tuned to resonance at the frequency of the undesired signal.

Fig. 13B shows schematically how this wave trap works. The antenna and ground system can be considered a voltage source, while the radio itself acts as a load for this source. Our wave trap is inserted in the circuit between the source and the load. Now, the source voltage will always divide between the wave trap and the load

in proportion to their impedances. When the source voltage (that is, the input signal) has the frequency to which the wave trap is tuned, the wave trap has a very high impedance, while the load (the radio) has its usual moderately low impedance. Therefore, nearly all of this particular signal voltage is developed across the wave trap, and very little is fed to the radio. At other frequencies, to which the wave trap is not tuned, the trap will have much lower impedance than the radio. Then most of the signal voltage will be developed across the radio, and very little will be wasted in the trap. Thus, our wave trap acts as a *signal rejector*; it keeps one narrow band of frequencies out of the radio, but lets all frequencies above and below this band go on to the set. This circuit is actually a filter. Since it eliminates a narrow band of frequencies and lets those above and below pass, it is called a *band-elimination* filter.

A coil and a condenser connected to form a parallel resonant circuit which can be used as a wave trap are shown in Fig. 13C. The trimmer type condenser need be adjusted only once, at the time when the wave trap is installed.

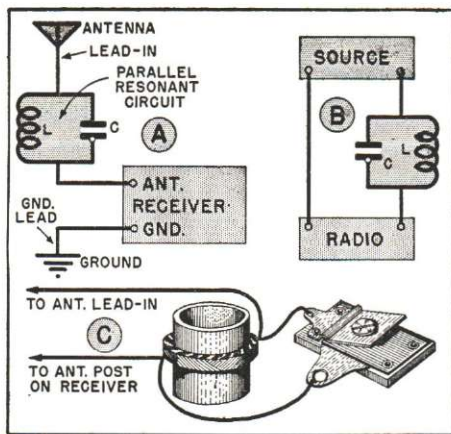

FIG. 13. Using a parallel resonant circuit as a wave trap.

Using a Series Resonant Circuit.

A series resonant circuit, when connected to the antenna and ground terminals of a receiver in the manner shown in Fig. 14A, also serves as a wave trap. We can analyze the action of this trap with the schematic diagram in Fig. 14B. Again, the antenna-ground system is represented as a voltage source and the receiver is shown as a load. The series resonant circuit is across this load. Notice—we have included an impedance Z in the voltage source. This is the impedance of the antenna-ground system. (This impedance was present also in the circuit we just discussed, but was not mentioned because there it was unimportant in the analysis of that circuit.)

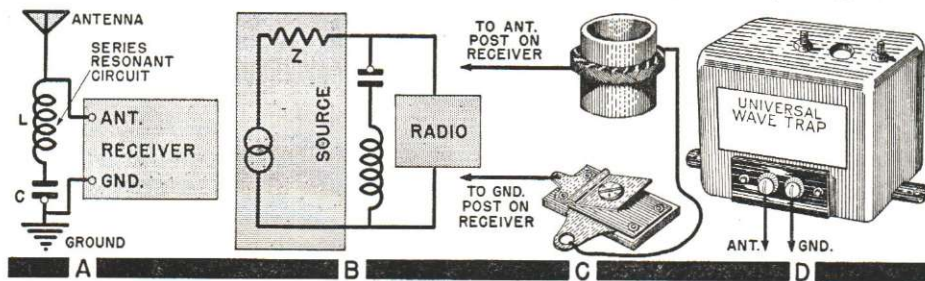

FIG. 14. How a series resonant wave trap should be connected.

Since the load and the series resonant trap are in parallel, there always will be the same voltage drop across each. The source voltage will divide between the impedance Z of the source and the combined impedances of the trap and the receiver. At the resonant frequency of the trap, its impedance will be very low—and, of course, the combined impedances of the trap and the receiver will be even lower. Thus, when the input signal is of the frequency to which the trap is tuned, practically all the voltage will be dropped across impedance Z , and very little will be dropped across the trap and the receiver. At other frequencies, the trap-receiver combination will have much higher impedance than Z , and nearly all the input signal voltage will be dropped across them. Again, we have a *signal rejector* which keeps one narrow band of frequencies out of the radio receiver.

The actual connections of a coil and condenser used as a wave trap of the series resonant type are shown in Fig. 14C. A completely assembled wave trap in a neat metal housing is illustrated in Fig. 14D. This is of the series resonant type, with connections like that in Fig. 14A; hence its two terminals are connected directly to the antenna and ground terminals of the receiver. The condenser can be adjusted by inserting a screwdriver through a hole in the top of the housing, and turning the adjusting screw.

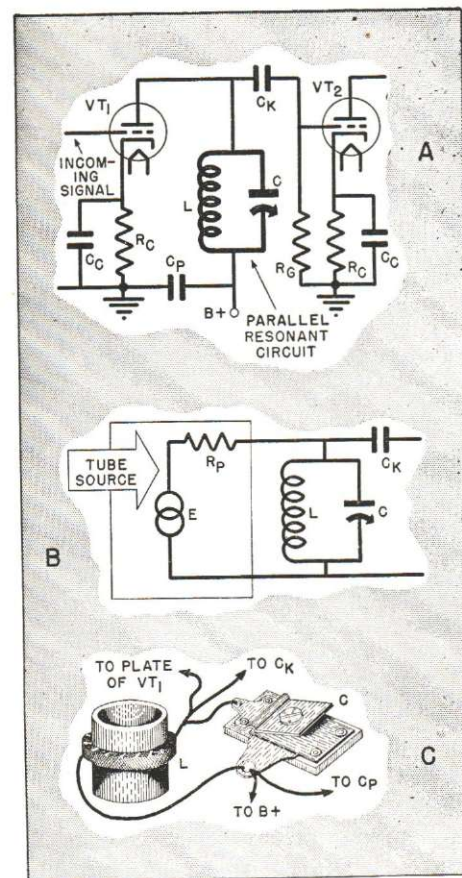

FIG. 15. A parallel resonant circuit used as a plate load in a vacuum tube circuit. A variable condenser may be used instead of the trimmer shown at C.

► Be sure to remember two very important facts about the two types of wave traps. A *parallel* resonant trap is connected *in series* with the receiver. A *series* resonant trap, on the other hand, is connected *in parallel* with the receiver. (A parallel resonant trap is often called a *series trap*, and a series resonant trap is often called a *parallel trap*, because of the way they are connected into the circuit. These terms, however, refer only to the method of connection, not to the kind of resonant circuit used.)

Wave Trap Data. Wave traps of the parallel resonant type generally

give best results on receivers which have a low input impedance, while those of the series resonant type will work best with receivers having a high input impedance. When the impedance of the receiver input is unknown, the practical radio man usually tries both types, selecting the one which gives the greater interference reduction.

Adjusting a wave trap is a simple matter. Connect it to the receiver in the proper manner, tune the receiver to the offending station, and then adjust the condenser in the wave trap until the offending signal is as weak as possible. If more than one station interferes, use one wave trap for each interfering station. Many all-wave superheterodyne receivers have built-in wave traps, which can be adjusted by the serviceman to tune out offending low-frequency code stations.

A wave trap is not a cure-all; there are many types of interference which it cannot reduce. You will learn more about the types of interference in later lessons.

TUNING CIRCUITS

Parallel Resonant Circuits in R.F. Amplifiers.

Tuned or resonant circuits are widely used for feeding radio frequency signals from one tube to another, as in tuned r.f. amplifiers. The tuned-impedance or high-gain amplifier circuit shown in Fig. 15A is an example. We are interested primarily in the action of the L - C circuit drawn in heavy lines, since the other parts of this circuit will be taken up in detail later in the Course.

For our purpose, we can represent the input side of this circuit (tube VT_1 and the L - C circuit) by the schematic diagram in Fig. 15B. Here we consider tube VT_1 to be an a.c. voltage source with a resistance R_p . You can see at once that any voltage produced by the tube source will

divide between the resistance R_P and the parallel resonant circuit.

If we tune the parallel circuit to resonance at the frequency of the incoming signal, it will have a very high resistance at this frequency. Consequently, most of the signal voltage of tube VT_1 will be developed across the parallel circuit and will be passed on to the grid of tube VT_2 through C_K . The parallel resonant circuit will have a low impedance for input signals of other frequencies, however, so they will be largely dropped in R_P and little energy will be passed on.

A parallel resonant circuit connected this way passes on signal voltages at the frequency to which it is tuned, and rejects voltages at all other frequencies. This means that the circuit possesses selectivity characteristics which make it very valuable for separating r.f. signals, so we can "pick out" and accept those from a desired station.

The picture diagram in Fig. 15C shows you the actual connections for a parallel resonant circuit, just as you might find them in the chassis of an r.f. amplifier. Notice how much simpler it is to draw the schematic diagram (Fig. 15A) than the picture diagram. Except for keeping certain leads (such as grid and plate leads) as far apart as possible, the manner in which parts are physically connected together is generally not important as long as the proper terminals are connected together electrically.

Series Resonant Circuits in R.F. Amplifiers. Another typical r.f. amplifier which uses a resonant circuit is shown in Fig. 16A. There is no difficulty here in recognizing the resonant circuit made up of condenser C and coil L , but the question is: Where is the source of voltage for this circuit? We must locate this source before we can tell whether the circuit

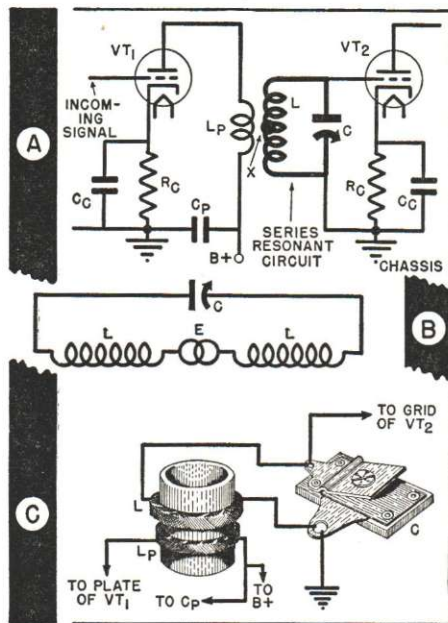

FIG. 16. A series resonant circuit used in a vacuum tube circuit. The connections at C are typical, although the coil and condenser may be of different shapes.

is of the series or the parallel type.

The answer to this question lies in the transformer made up of coils L_P and L . The r.f. signal current supplied by the plate of tube VT_1 flows through coil L_P and induces an r.f. voltage of corresponding wave form in coil L . The field about L_P links with L , inducing a voltage WITHIN L , just the same as if a voltage source were placed in series with L . In fact, we can represent the resonant circuit by the diagram in Fig. 16B, where the voltage induced within L is shown as the generator E .

By tracing from the generator in Fig. 16B, you can see that to make a complete circuit we must go through part of coil L , through condenser C , and through the other part of coil L back to the generator. Therefore, this is obviously a series circuit—as is any resonant circuit in which the voltage is induced in the coil.

The identification of a circuit of this kind puzzles many radio men. Remember this one fact, and you'll have no difficulty in identifying the circuit:

Whenever a voltage is induced in the coil of a tuned circuit, the circuit is series resonant.

When L and C in this series resonant circuit are tuned to the frequency of the induced signal voltage, they act as a resistance of very low ohmic value. A large r.f. current, therefore, flows through the series resonant circuit, developing a correspondingly large voltage across condenser C , and this voltage acts on the grid and cathode of tube VT_2 . At all other frequencies, the $L-C$ circuit acts as a high reactance. The r.f. currents at these other frequencies are therefore low, so the voltages developed across C are low, thus the desired signals are favored. A series resonant circuit thus gives selectivity besides giving resonant amplification of the desired signal. Chassis connections as they might be for a series resonant circuit in an r.f. amplifier are shown in Fig. 16C.

Resonant Circuits in a Superheterodyne Receiver. You have just seen how series and parallel resonant circuits each contribute a certain amount of selectivity. In superheterodyne receivers, series and parallel resonant circuits are often connected together, in the manner shown in Fig. 17A, to secure even greater selectivity. Again the resonant circuits are shown in heavy lines.

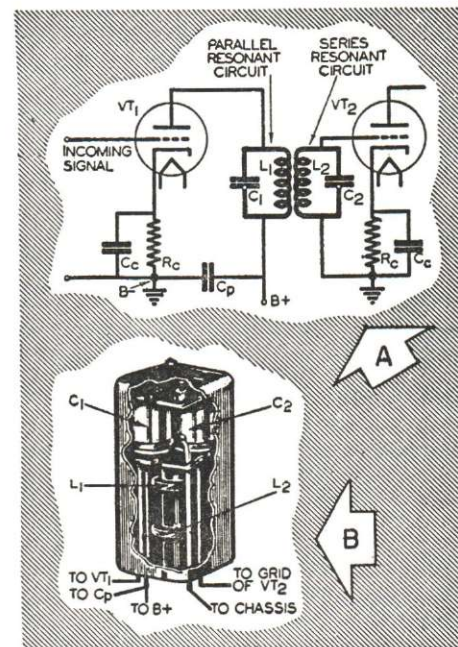

FIG. 17. In the i.f. section of a superheterodyne, both series and parallel resonant circuits are used.

First consider only circuit L_1-C_1 ; clearly, this is a parallel resonant circuit as is that shown in Fig. 15A, because tube VT_1 is its signal source. At resonance, then, a large current flows through coil L_1 and condenser C_1 .

Now let us bring the L_2-C_2 circuit into our picture. The r.f. current flowing through coil L_1 induces in coil L_2 an r.f. voltage which acts in series with L_2 and C_2 , just as in Fig. 16A. Thus L_2 and C_2 form a series resonant circuit. The actual chassis connections for this double resonant circuit might be as shown in Fig. 17B.

Coupling Radio Circuits

Now that we are well acquainted with resonant circuits and with a few of their applications, we are ready to take up the different ways in which a resonant circuit can be coupled (connected) to a source of voltage.

ANTENNA COUPLING METHODS

The antenna circuit of a radio receiver is one of the simplest and best-known applications for coupling systems, so we will use it as our practical example in connection with this study of coupling methods. Suppose we have an antenna and a ground,

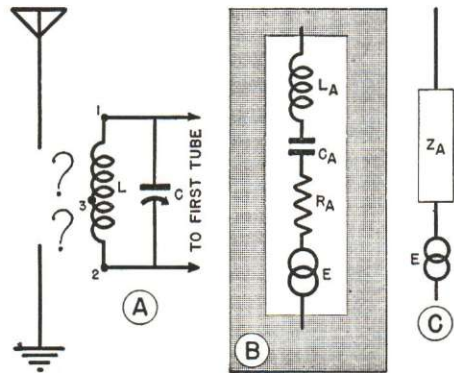

FIG. 18. How can we couple the resonant circuit to the antenna-ground?

and want to connect or couple them to the resonant or tuned circuit which feeds the first r.f. stage of a radio receiver, as shown in Fig. 18A.

The antenna-ground circuit will be a source of voltage, as it picks up energy from the traveling radio waves. However, like all other sources, the antenna-ground circuit has an impedance. It has a certain amount of resistance and also has some inductive and some capacitive reactance. Hence, the antenna-ground circuit can be represented as in Fig. 18B. As you can see, it is a series resonant circuit

itself, but in practice antennas are so dimensioned that they are resonant only in the short-wave bands. Thus, at the lower or broadcast frequencies, the combination is far off resonance, and acts like a condenser in series with a resistance.

We can lump together all the opposition as an impedance, as shown in Fig. 18C. We don't need to know the exact amount of either the impedance of Z_A or the voltage of E , but we do want to know how we can couple from this circuit into the resonant circuit.

There are four simple ways to couple an antenna to a single resonant circuit:

1. Direct coupling.
2. Capacitive coupling.
3. Direct inductive coupling.
4. Inductive coupling.

Let us consider them one by one.

1. Direct coupling, as shown in Fig. 19A, is the first and simplest solution to this problem. The entire antenna voltage is applied across our L - C circuit, making it a *parallel resonant circuit*. The resonant circuit then becomes the load, and forms a voltage divider with the antenna impedance Z_A , as shown in Fig. 19B.

As you have learned, this tuned circuit will act as a resistance of high ohmic value to a signal having the resonant frequency to which L and C

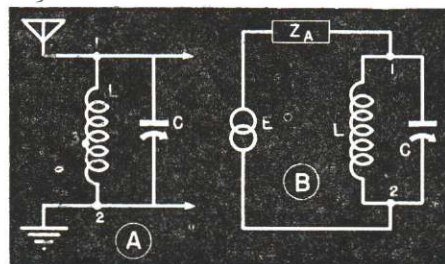

FIG. 19. Direct coupling.

are tuned. At this desired frequency, then, the resistance of the input circuit is much higher than the antenna impedance, and the greatest part of the signal voltage will exist across the resonant circuit and be passed on to the grid of the first tube. At all other frequencies, however, this resonant

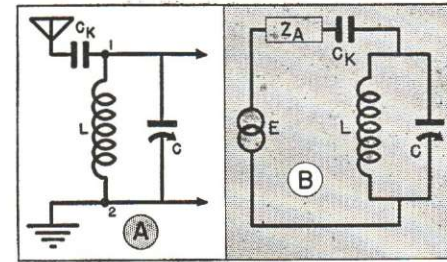

FIG. 20. Capacitive coupling.

circuit will act as a low impedance, and a far smaller voltage will be developed across it.

2. Capacitive coupling, as illustrated in Fig. 20A, is the second method. As you can see, it is simply direct coupling with a low-capacity condenser C_K inserted in the antenna lead-in.

Using the condenser gives an improvement over the direct coupling circuit shown in Fig. 19. In direct coupling, the selectivity is more sharp the higher Z_A becomes. The voltage division for off-resonant signals is not effective until the resonant circuit impedance has dropped to some value near (or below) the Z_A value. Therefore, when Z_A is small, the parallel resonant impedance must drop a great amount before off-resonant signals are eliminated. This means signals near the resonant frequency are not cut out, so the tuning is broad.

Inserting the condenser C_K as shown in Fig. 20A places its reactance in series with the antenna impedance as shown in Fig. 20B. Hence, it is added to the series impedance, increasing the

effectiveness of the circuit. Now the parallel impedance does not have to drop so far before its value compares with that of the series impedance, so the circuit rejects frequencies closer to the resonant value.

3. Direct inductive coupling of the form shown in Fig. 21A applies the antenna voltage to only a part of the resonant circuit. By having the tap 3 well up on the coil (near 1), the circuit still acts as a parallel resonant circuit, but only a part of its impedance will be between 2 and 3, and hence in the antenna-ground circuit. This can result in a better voltage-dividing action, and transformer step-up can be used to increase the voltage slightly. The position of point 3 can be chosen to secure maximum gain with fair selectivity or low gain with good selectivity, as desired.

4. Inductive coupling, shown in Fig. 22A, is perhaps the most widely used of all methods for coupling the antenna system to a resonant input circuit. (Inductive coupling is also known as transformer coupling or sometimes as indirect inductive coupling.) Antenna current flowing through

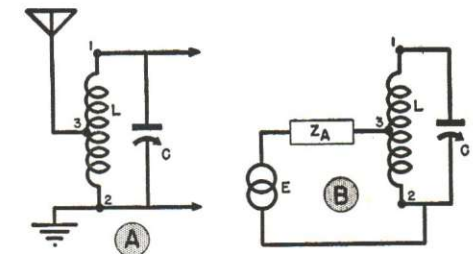

FIG. 21. Direct-inductive coupling.

coil L_1 sets up a varying magnetic flux M which links coil L and induces in it a voltage which acts as if it were in series with L . Inductive coupling can be designed to give very high gain, to give high selectivity, or to give a satisfactory compromise between the two, as desired, by varying the num-

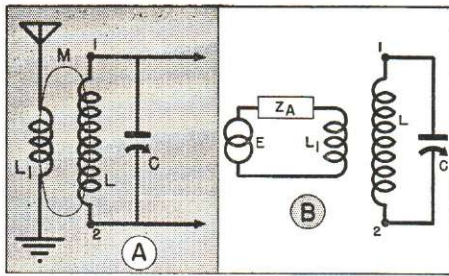

FIG. 22. Inductive coupling.

ber of turns in coil L_1 and its position with respect to coil L .

► The coupling methods shown in Figs. 19 to 22 for antenna circuits are essentially the same as those you will encounter in a host of other radio applications, the most common of which is the coupling together of the plate circuit of one tube and the grid circuit of the following tube. We will study these circuits in detail in later lessons, when we take up complete radio stages.

INDUCTIVE COUPLING FACTS

Any inductively coupled circuit can be simplified to the three essential parts shown in Fig. 23: a source, a coupling transformer, and a load. The source may or may not have appreciable impedance, and may be delivering either an a.f. or an r.f. signal voltage. The transformer may be of the air-core type, if its two windings (coils) are separated only by air or some other insulating material, or it may be of the iron-core type. The

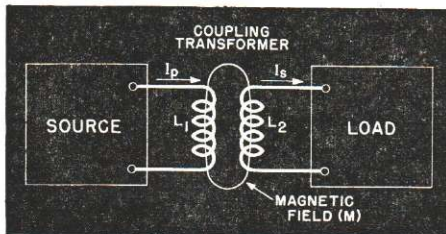

FIG. 23. Any inductively coupled circuit can be represented by this simplified circuit.

load likewise may have impedance. Either the source, the load, or both, may be resonant circuits. In an inductively coupled circuit of this sort, the source sends through the transformer primary (coil L_1) a current I_P which induces in coil L_2 a voltage that acts directly on the load, making current I_S flow through the load.

The current flow through the load means that the load is taking power from the coupling transformer, and further, this power must be given to the coupling transformer by the source. Hence, the source "feels" the load through the coupling, and the current flow I_P is automatically ad-

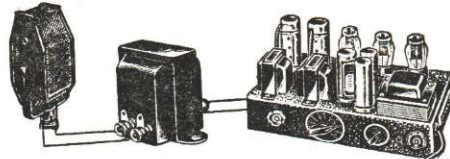

FIG. 24. An audio frequency example of inductive coupling.

justed so that the required power is delivered, provided the coupler is properly designed. You will go into this in more detail in later lessons.

Practical A.F. Application. A very common and practical low-frequency application of inductive coupling is that shown in Fig. 24, where a microphone serves as a source of a.f. signals, an audio amplifier serves as a load, and an iron-core coupling transformer serves to transfer to the source the effects of the load. This coupling transformer can be designed to deliver maximum voltage or maximum power to the load.

Practical R.F. Application. A radio frequency application of inductive coupling is the little "pill-box" you see connected between the two halves of some short-wave antennas in an arrangement similar to that shown in Fig. 25A. A close-up view of this box

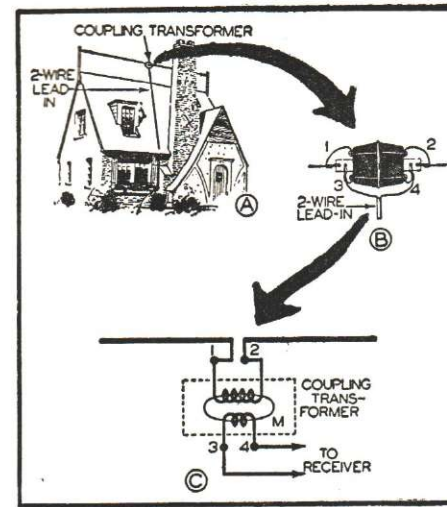

FIG. 25. An r.f. application of inductive coupling.

appears in Fig. 25B. Generally, all you will find inside it are two coils forming an air-core transformer, which is connected between the two halves of the antenna and the two-wire lead-in (transmission line) in the manner shown in Fig. 25C.

► We might get a little in advance of our subject here to explain why this transformer is used. You know that an antenna has an impedance at its connecting terminals; likewise, the input of a radio receiver has impedance. As later lessons will show, maximum power can be transferred from one circuit to another only when their impedances are equal—or, as radio men say, matched. The simplest way to match impedances is to couple the circuits with a transformer which has a certain calculated number of turns in its primary and secondary windings. Thus, the transformer in Fig. 25B is used as an impedance-matching transformer so that maximum signal power will be transferred from the antenna to the set.

Types of Inductive Coupling. The action of a coupling transformer, as

you already know, depends upon the fact that current flowing through the primary winding produces a varying magnetic flux. When all of the magnetic flux produced by the primary winding links with (passes through) the entire secondary winding, we have what is known as *unity coupling*. While unity coupling is just about impossible to secure in a practical transformer, a very close approach to it can be made; this is called *tight coupling*. On the other hand, when only a part of the magnetic flux links with the secondary winding, the coupling is said to be *loose* or *weak*, and the load will have less effect upon the source. If none of the magnetic flux links with the secondary winding, there is *zero coupling*. Let us consider how tight or weak coupling can be secured in actual coupling transformers.

Tight Coupling. When the two wires which form the primary and secondary windings of a coupling transformer are wound side by side on the coil form, as indicated in Fig. 26A, we have tight coupling; now practically all of the flux produced by the primary winding must link with or

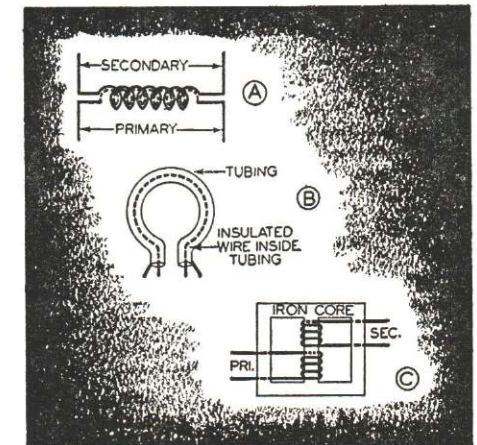

FIG. 26. Unity coupling can be secured as shown here.

pass through the entire secondary winding. In ultra-high-frequency apparatus, the same result often is secured by using one or more turns of copper tubing as the primary coil, and threading an insulated wire through this tubing to serve as the secondary coil. This is illustrated in Fig. 26B. When an iron core is used, as in Fig. 26C, tight coupling is secured without the necessity for having the turns of the two windings close together. In fact, the primary and secondary may be two separate coils placed one inside or alongside the other, as long as nearly all of the magnetic flux passes

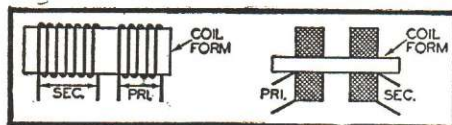

FIG. 27. Loose coupling.

through both coils. Iron cores are used in coupling transformers designed for audio amplifier circuits.

Loose Coupling. Where loose coupling is desired, as in some r.f. transformers, the two coils generally are arranged in one of the two ways shown in Fig. 27, so that there is considerable space between the coils. Only a small fraction of the magnetic flux thus links with the secondary coil.

► When two coils are loosely coupled to each other, we really have a condition where a small part of the primary coil is *tightly coupled* with a small part of the secondary coil, and the remaining parts of the primary and secondary coils are not coupled to anything. These uncoupled parts of

the primary and secondary coils can be considered as separate, extra coils in their respective circuits. Thus we can, if we wish, think of a loosely coupled circuit as being a tightly coupled circuit with an extra coil in its primary circuit and an extra coil in its secondary circuit. It is often very convenient to analyze a loosely coupled circuit this way. These extra inductances are known as the *primary leakage inductance* and the *secondary leakage inductance*, since they exist because some magnetic flux leaks off without linking the other coil.

As you learn more about radio apparatus, you will see how important is this left-over or leakage inductance in the actual operation of radio circuits which employ loose coupling. Also, you will discover that moving the original coils closer together increases the coupling, reduces the values of these leakage inductances, and affects the operation of the circuit in many other ways.

Looking Forward. Now that we have a general understanding of resistors, coils, condensers, vacuum tubes, and tuned circuits, we can proceed to connect all these into actual vacuum tube circuits and study their operation in connection with tubes. This we will do in our next lesson, in which you will be introduced to a number of typical circuits actually being used in radio receivers and other radio apparatus. You will probably be surprised, after you have completed your study of this next lesson, to see how much you have learned from the first ten lessons in your Course.

Lesson Questions

Be sure to number your Answer Sheet 9FR-3.

Place your Student Number on every Answer Sheet.

Send in your set of answers for this lesson immediately after you finish them, as instructed in the Study Schedule. This will give you the greatest possible benefit from our speedy personal grading service.

- Does *reducing* the resistance of a series resonant circuit: 1, increase; or 2, *decrease* the selectivity of the circuit?
- When a series resonant circuit is tuned to resonance, is the circuit current flow: 1, at its highest value; or 2, *at its lowest value*?
- Suppose the capacity of C in a series resonant circuit is increased. Will the circuit now tune to: 1, *the same frequency*; 2, *a higher frequency*; or 3, *a lower frequency*?
- At resonance, does a parallel resonant circuit act like: 1, *a coil*; 2, *a condenser*; 3, *a high resistance*; or 4, *a low resistance*?
- When not tuned to resonance, does a parallel resonant circuit act like the part: 1, *having the higher reactance*; or 2, the part having the lower reactance?
- To obtain the highest possible selectivity, would you use a coil having: 1, a high Q; 2, *a low Q*; or 3, *a medium Q*?
- What will happen to the inductance of an air-core coil when a powdered-iron core is placed inside the coil? DECREASE THE MAGNETIC FLUX
- When a voltage is *induced* in the coil of a resonant circuit, is the circuit: 1, series resonant; or 2, *parallel resonant*?
- Name the four methods of coupling an antenna to a resonant circuit.
DIRECT COUPLING. CAPACITIVE COUPLING. DIRECT INDUCTIVE COUPLING. INDUCTIVE COUPLING!
- What condition is necessary for *unity coupling*?
When ALL OF THE MAGNETIC FLUX PRODUCED BY THE PRIMARY WINDING LINKS WITH THE ENTIRE SECONDARY WINDING.



DETERMINATION

Did you ever watch a steamroller — an old-fashioned one with clanging gears, escaping steam and great clouds of black smoke belching from the stack? Wasn't it a thrill to see that great machine level out obstacles in its path, leaving a perfectly smooth roadway? The word "determination" always brings to my mind that picture of a steamroller — a machine which goes places once the "full steam ahead" lever is thrown.

So, too, are *you* determined to go places, to achieve success and happiness. One by one you are completing your lessons, studying hard and making sure you understand everything; step by step you are approaching that greatest of all goals—SUCCESS.

Of course, the way is long and not always easy. But whenever the going gets a little tougher than usual or you feel a bit discouraged, just bring out that old determination, and back it up with every single ounce of ambition you have.

J. E. Smith