

**RADIO COILS AND HOW  
THEY WORK**

**6FR-3**



**NATIONAL RADIO INSTITUTE**

**WASHINGTON, D. C.**

**ESTABLISHED 1914**

## STUDY SCHEDULE NO. 6

This schedule will help you to master the sixth part of your N.R.I. Course. For each step, read the specified pages first at your usual reading speed, then reread slowly one or more times. Finish with one quick reading, then answer the Lesson Questions specified for that step.

- 1. Quickly Review Pages 12 to 18 of Lesson 1FR-3.  
Start with "Radio Uses for Magnetism" on page 12, and read to the bottom of page 18 just once.
- 2. Coil Fundamentals . . . . . Pages 1-6 of this Lesson  
You learn basic facts about magnetic circuits of coils, and find out what determines the amount of magnetic flux a coil will produce. Answer Lesson Questions 1 and 2.
- 3. Using Coils to Produce Motion . . . . . Pages 6-8  
Three different ways to explain the operation of motion-producing coils are studied. You can use them to explain the operation of radio parts like relays, headphones, magnetic loudspeakers, electrodynamic loudspeakers, p.m. dynamic loudspeakers, and moving-coil meters. Answer Lesson Question 3.
- 4. Using Coils to Produce Voltage . . . . . Pages 8-14  
Step by step you learn the meaning of the basic coil rule that the induced voltage depends upon how fast the flux linkages are changing. Finally, you fix this knowledge in your mind by considering three examples of voltage-producing coils: Dynamic microphone, magnetic phono pick-up and transformer. Answer Lesson Questions 4, 5, 6, and 7.
- 5. Basic Idea of Inductance . . . . . Pages 15-23  
Important principles which govern the behavior of coils in a.c. circuits are taken up one by one. You also learn about combinations of coils and about variable inductances. Answer Lesson Questions 8 and 9.
- 6. Simple Coil-Resistor Circuit . . . . . Pages 24-28  
Here's where you learn how to combine voltages correctly in a.c. circuits containing a coil. Phase relationships and uses for vectors are explained simply from a practical standpoint. Answer Lesson Question 10.
- 7. Mail Your Answers for Lesson 6FR-3 to N.R.I. for Grading.
- 8. Start Studying the Next Lesson, on Condensers.

## RADIO COILS AND HOW THEY WORK

### Coil Fundamentals

**Radio Uses for Coils.** Coils have many important jobs in radio receivers and transmitters. Working alone or in partnership with condensers and resistors, coils make it possible to tune in stations, to remove hum from power supply circuits, to keep signals in proper paths, to change a.c. voltages to higher or lower values, to transfer signals from one circuit to another without wire connections, and to do a host of other equally important jobs, all of which we will take up in this Course.

**Definition of a Coil.** In its simplest form, a *coil* is nothing more than

one or more turns or loops of wire, usually wound in a circular or helical shape. More often, however, a radio coil also has certain accessories, such as a coil form, an iron core, or a metal housing or shield.

**Basic Action.** Coils produce magnetic lines of force, known also as *magnetic flux*. No matter what kind of coil we have—large or small, thick or thin, wound around air or iron—it produces magnetic flux whenever we send current through the coil.

Many different types and sizes of coils are used in radio, in order to get a particular desired amount of this



In this Western Electric magnetic-tape sound recorder, coils have many important jobs. A coil in the dynamic microphone produces the audio signal. An a. f. input transformer inside the cabinet transfers the signal to the first a. f. amplifier stage. Other transformers transfer the signal to succeeding amplifier stages to boost its strength, then feed it to a coil which magnetizes a moving steel tape. Sounds are thus recorded on the long tape. A flip of a switch reverses the process, enabling the speaker to hear her own voice from the loudspeaker, which has two more coils. Still another coil demagnetizes the tape to erase previous recordings.

magnetic flux in a particular and definite location inside or near the coil. This flux makes it possible for a coil to offer more opposition to the

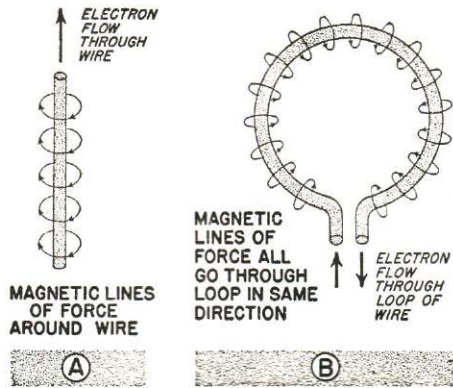

FIG. 1. Review of the basic principle applying to coils—that magnetic lines of force are produced whenever electrons flow through a wire or other object.

flow of alternating current than direct current, to transfer energy to another circuit without connecting wires, to produce mechanical motion, to convert mechanical motion into a correspondingly varying voltage, and do all the other jobs which are described in connection with coils in this and later lessons.

### Fundamental Facts About Coils.

You have already learned that whenever we send current through a straight piece of wire, magnetic lines of force are produced around the wire. These lines of force encircle the wire in much the manner shown in Fig. 1A. They are distributed along the entire length of the wire, because the electrons are distributed throughout the wire and each electron has its own circular magnetic field. The larger the current (the greater the number of electrons) we send through the wire, the more lines of force there will be—just as we might naturally expect. Furthermore, reversing the direction of the

current will reverse the direction of the magnetic lines of force.

If we bend the wire into a loop or single-turn coil as shown in Fig. 1B, the lines of force all pass through the center of the loop in the same direction and give a concentration of magnetic flux there. The greater the current, the more flux we have passing through the coil.

If we add more turns of wire as in Fig. 2, still more flux is concentrated inside the coil. Each current-carrying turn of wire contributes its share of flux to the total amount, so the more turns of wire we have in a coil, the more flux we get from a given current.

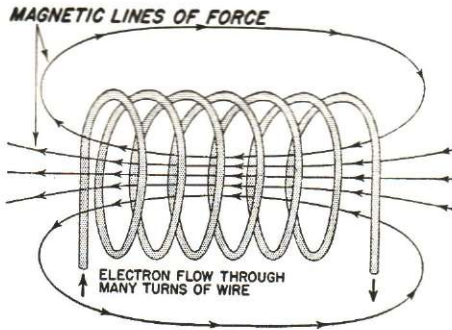

FIG. 2. A coil is simply a device which concentrates in a useful manner the magnetic lines of force produced by moving electrons.

The number of turns is, therefore, just as important a factor as current in determining how much flux a coil will produce. Many of these facts you will recognize as a review of what you have already studied about magnetic lines of force.

### MAGNETIC CIRCUITS

The magnetic lines of force which are produced by a coil can exist *only as complete loops having no ends, passing through and around the coil turns which produced the lines*. Thus, the lines of force going out of the coil at the left and into it at the right

in Fig. 2 are each portions of complete loops like those shown above and below the coil. In many cases, it would be impractical to show complete loops on diagrams, so for convenience we show only those portions of the loops in which we are most interested.

Each coil may have thousands of such loop paths, all passing through part or all of the coil and going out in all directions from the ends of the coil. Together, the paths of these magnetic lines of force make up the *magnetic circuit* of the coil.

The material inside a coil is called the *core* of the coil. Sometimes the core material is continued around the outside of the coil, and then forms the chief magnetic circuit of the coil.

When the path for the magnetic lines is entirely through air, as it is in Fig. 2, we have an *air-core coil*.

When a coil of wire is wound or placed around an iron or steel ring, as shown in Fig. 3, magnetic lines of force are produced in this core by the current flow in the coil turns. As we will shortly see, the iron core is a better magnetic circuit than air, and a greater number and concentration of flux lines exists. This is called an *iron-core*

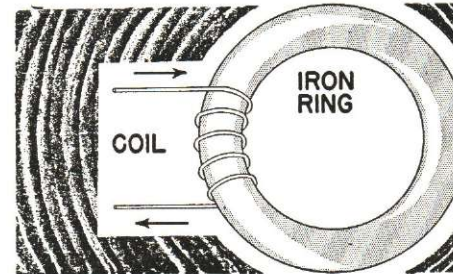

FIG. 3. A coil wound on an iron ring produces more flux and a greater concentration of flux than a similar coil having only air for a core.

coil, and you will often meet it in radio work. The iron core will usually have some other shape than a ring, but there will usually be a continuous



Courtesy Western Electric Co.

The direction-finding loop antenna of this 30-ton Douglas DC-4 transport plane, being inspected here by a United Air Lines communication engineer, is nothing more than a coil enclosed in a tubular aluminum hoop. It is mounted inside the nose of the plane, but the magnetic fields of radio waves from beacon stations go right through the non-magnetic metal covering of the loop and through the loop housing.

path through iron for the magnetic lines of force.

**Three Magnetic Terms.** The magnetic circuit of a coil is just as important to us as the electric circuit in which the coil is connected. In fact, magnetic circuits are similar to electric circuits in many ways, and have terms which correspond to the voltage, resistance and current of an electric circuit. The terms are *magnetomotive force*, *reluctance* and *flux*, and they have the same relationship to each other as that expressed by Ohm's Law for voltage, resistance and current in an electric circuit.

**1. Magnetomotive Force.** Just as we have an electromotive force or voltage which forces current around

an electric circuit, so do we have in every current-carrying coil a *magnetomotive force* which forces the flux around the magnetic circuit.

A true indication of the strength of the magnetomotive force of a coil can be obtained by multiplying the coil current in amperes by the number of coil turns, giving the number of *ampere-turns*. The greater the magnetomotive force (ampere-turns), the more flux it sends through the magnetic circuit, other things being equal. This corresponds to the Ohm's Law relationship that increasing the voltage will increase the current.

A clear understanding of ampere-turns can prevent plenty of headaches if you ever wind experimental coils for electromagnets or relays. For example, adding more turns of the same size wire doesn't do any good if you still use the same coil voltage, because it doesn't change the ampere-turns. Here is the explanation: The extra wire increases the coil resistance, and this reduces the current just enough to offset the increase in turns.

**EXAMPLE:** A 50-turn coil carrying 4 amperes gives 200 ampere-turns. Adding 50 more turns of the same wire gives 100 turns, but doubles the coil resistance. Therefore, if the coil voltage is the same as before, the extra turns just about cut the current in half, to 2 amperes. Multiplying 2 by 100 gives 200 ampere-turns, so the strength of the magnetic field stays the same even though the turns were doubled.

It should be pointed out that many radio coils are used in circuits where the resistance of the coil is negligibly small in comparison to the total resistance of the circuit. Here the coil current stays essentially the same even though we double the coil resistance, so increasing the number of turns in-

creases the ampere-turns and gives a more powerful coil.

Remember, then, that the magnetomotive force (the force which sends magnetic flux around the magnetic circuit of a coil) depends upon the number of ampere-turns in the coil. The more ampere-turns we have, the more flux we get.

**2. Reluctance.** Just as resistance limits the amount of current flow in an

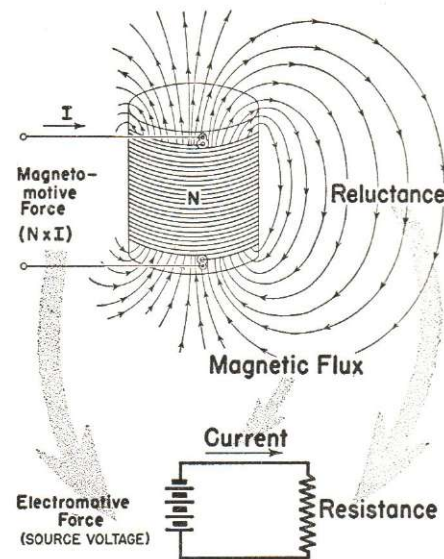

FIG. 4. Similarity between magnetic and electric circuits. The total reluctance is here the reluctance of the air through which the magnetic flux loops flow. Lines of force go out of the ends of the coil in all directions, but only a few of the lines can be shown in a diagram of this nature.

electric circuit, so does the flux path of every magnetic circuit have *reluctance* which offers opposition to magnetic flux. This reluctance is distributed along the entire path taken by the flux, but for study purposes it can be considered as concentrated at one point like a resistor. The comparison between reluctance and resistance is shown in Fig. 4. Here the magnetic path is through air.

The lower we make the total reluctance of a magnetic circuit, the more flux we will get from a given magnetomotive force. This corresponds to the Ohm's Law relationship that lowering the resistance increases the current. On the other hand, increasing the reluctance cuts down the amount of flux.

From the standpoint of reluctance, all materials can be divided into two groups: 1. Non-magnetic materials; 2. Magnetic materials.

**Non-Magnetic Materials.** In this group, we have air and other non-magnetic materials, like paper, glass, bakelite, wood, brass, aluminum and copper. A coil having only non-magnetic materials in its core and in the form which supports the wire is an air-core coil, because the magnetic circuit has the high reluctance of air.

**Magnetic Materials.** This group includes iron, steel, ferrous (iron) alloys, and a few other metals and alloys which give magnetic circuits a lower reluctance than air.

Magnetic materials make it possible to secure large amounts of flux with only moderate values of magnetomotive force. A coil having magnetic material in its magnetic circuit is known as an iron-core coil.

**How Reluctance Affects Flux.** You can think about reluctance much as you do about resistance. Thus, the longer the magnetic circuit, the higher is its reluctance. (Compare with an electric circuit, where increasing the length of a wire increases its total resistance.) Conversely, shortening the path for flux decreases the total length of the magnetic circuit and thereby decreases the total reluctance.

The greater the cross-sectional area of a magnetic circuit, the lower is its reluctance. (In electricity, the thicker a wire, the lower is its resistance for a given length.) Conversely, reducing the cross-sectional area of the magnetic path increases the reluctance.

The kind of magnetic material used has considerable bearing on the total circuit reluctance. Some materials are better magnetic conductors than others; the technician says the material has better *permeability*, just as copper has better conductivity than iron and therefore provides a lower-resistance path for current.

**Permeability.** The radio term which most conveniently expresses how much more flux we will obtain with a given magnetic material than with air is

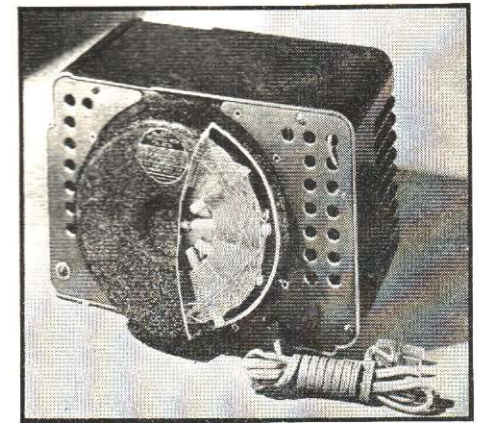

Courtesy Continental Radio & Television Corp

Coils are wound in many different shapes and sizes. In this cut-away view of the rear of a table-model Admiral receiver you see a basket-weave coil known by the trade name "Aeroscope," serving as a built-in loop antenna.

*permeability*. In a practical sense permeability expresses how well a material can conduct magnetic flux. (*Permeability* comes from *permeate*, which means to pass through.)

The permeability of a core material determines what the total reluctance of the core will be; when the permeability goes up, the reluctance goes down, and vice versa.

The permeability of air and all other non-magnetic materials is by agreement given the numerical value of 1. Magnetic materials all have higher permeability values than 1, with ac-

tual values ranging from about 50 all the way up to 10,000, or even higher for certain special alloys.

**Air Gaps.** In electrical circuits, we often find paths with different resistances in series. In magnetic circuits, we often find different magnetic materials in series, as shown in Fig. 5. Here we have a magnetic circuit made chiefly of iron having low reluctance, but with a high-reluctance air gap at one point.

This is an actual case where most of the reluctance is concentrated at one point (in the air gap), with the rest of the circuit having such low reluctance.

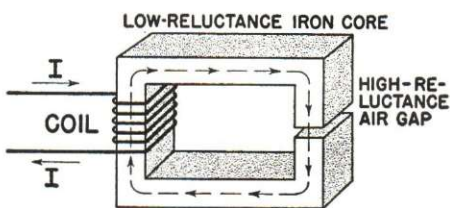

FIG. 5. The flux produced by this coil travels along a magnetic circuit consisting of an iron core and a short air gap. The total reluctance is but slightly higher than the air gap reluctance.

## Using Coils to Produce Motion

There are a great many radio devices in which we use flux to produce motion. Typical examples are meters, loudspeakers and automatic switches (called relays).

**Three Explanations.** There are three fundamental ways of explaining how current-carrying coils can produce motion. Once you clearly understand these fundamental explanations, you can choose whichever is the most convenient for explaining the action of any motion-producing coil you may encounter.

**1. Attraction and Repulsion of Magnetic Poles.** The basic law of

tance that it is comparable to the conducting wires in the electric circuit of Fig. 4.

**3. Magnetic Flux.** Finally, corresponding to current in an electric circuit we have magnetic flux (magnetic lines of force) in a magnetic circuit. Just as current is equal to voltage divided by resistance, so is flux equal to magnetomotive force divided by reluctance.

**Summary.** The Ohm's Law relationships for these three magnetic characteristics can be summarized as follows:

*You can INCREASE the amount of flux either by increasing the magnetomotive force or decreasing the reluctance.*

*You can DECREASE the amount of flux either by decreasing the magnetomotive force or increasing the reluctance.*

Every change in flux is thus due to a change either in magnetomotive force or reluctance. This thought is well worth keeping in mind during the remainder of your study of coils.

magnetism which you took up in an earlier lesson (like poles repel, and unlike poles attract) is highly convenient for explaining the operation of many types of coil devices.

Whenever a magnetic circuit made of iron or other magnetic material is broken by an air gap, the ends of the iron core on each side of the air gap will have opposite magnetic polarity due to the flux which flows through the iron magnetic circuit. The end which magnetic lines of force enter will be the S pole, and the end which lines of force leave will be the N pole. In other words, flux mag-

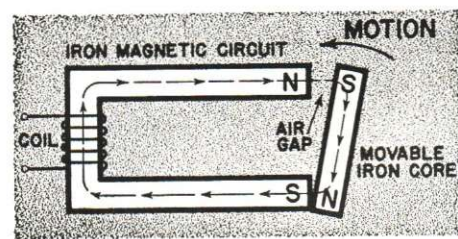

FIG. 6. Movement due to the attraction of unlike magnetic poles.

netizes any magnetic material through which it passes.

When you place a nail or other piece of iron on the pole of a permanent magnet, this nail acts like a magnet, and is capable of picking up small iron objects. The nail alone would not do this, so we say that the nail is *inductively magnetized* by the flux from the permanent magnet.

Since the core ends which are on opposite sides of an air gap have opposite polarity, they tend to attract each other in accordance with the law of magnetism. If a portion of the iron magnetic circuit of a coil is movable, as is the case in Fig. 6, this attraction across the air gap will result in a motion which tends to bring the N and S poles closer together.

If an electromagnet is pivoted in the air gap between N and S poles in the manner shown in Fig. 7A, the repelling action between like poles will cause rotation in a clockwise direction as indicated by the arrows. If there

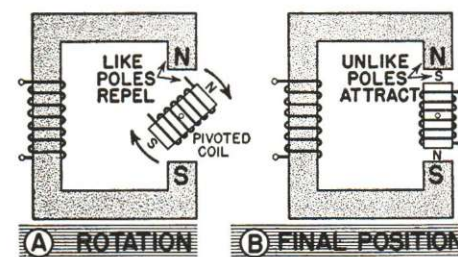

FIG. 7. Rotation due to repulsion of like poles (A) and attraction of unlike poles (B).

is no retarding force, this coil will finally come to rest at the position shown in Fig. 7B, in which the unlike poles are as close as they can get to each other. Magnetic poles thus attract and repel in the same manner regardless of whether they are on permanent magnets, electromagnets or inductively magnetized pieces of iron.

### 2. Position of Maximum Flux.

In some cases it is more convenient to explain the action of a coil device by means of the following basic rule: Whenever a movable magnetic object is in or near a magnetic circuit, this object will tend to move to the position which gives *maximum flux* in the magnetic circuit.

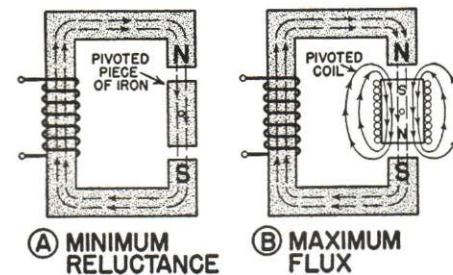

FIG. 8. Pivoted objects in magnetic circuits take the positions shown here.

In the case of a movable iron object, this rule means that it will move to a position wherein its longest dimension is parallel to the magnetic lines of force in its vicinity. The movable object is then placing as much as possible of its length in the magnetic circuit, thereby lowering the reluctance of the magnetic circuit and giving maximum flux.

In the case of a movable electromagnet, this coil will take a position wherein its flux acts in the same direction as the original flux. The two fluxes then add, so as to give maximum flux as specified by the rule.

Thus, an iron object pivoted in the air gap between N and S poles of a

magnetic circuit will take the position shown in Fig. 8A, with its longest dimension parallel to the lines of force in the air gap. You will shortly learn that in this position the magnetic circuit also has minimum reluctance.

A current-carrying coil freely pivoted in the air gap between the N and S poles of a magnetic circuit will take the position shown in Fig. 8B. Its flux is then aiding the air-gap flux, thereby giving *maximum flux*.

**3. Position of Minimum Reluctance.** Last to consider, but equally as useful, is the rule which says: A movable magnetic object located in or near a magnetic circuit will tend to take a position which makes the reluctance of the magnetic circuit a *minimum*.

Minimum reluctance occurs when the greatest possible portion of the magnetic circuit is through iron or some other low-reluctance magnetic material.

The movable piece of iron in Fig. 8 is moving to the position of minimum reluctance, because the reluctance is a minimum here when the air gap is closed up. Likewise, the pivoted iron object in Fig. 8A is in the position of minimum reluctance, because it is in the position which gives the shortest possible air gaps.

Since lowering of reluctance makes flux increase, the position of minimum reluctance is identical with the position of maximum flux. It is simply more convenient sometimes to think of reluctance rather than flux. Likewise, since opposite poles at an air gap attract each other and tend to close up the air gap, thereby lowering the reluctance and increasing the flux, the law of magnetic attraction expresses exactly the same result as the other two ways of explaining the motion produced by a current-carrying coil.

## Using Coils to Produce Voltage

Some microphones and some phonograph pick-ups are coil devices which use changes in magnetic lines of force (flux) to produce a voltage. The basic rule is: *Whenever the flux linkages of a coil are changed, a voltage is induced in the coil.* Before going into the explanation of this rule, let us first see what flux linkages are.

### FLUX LINKAGES

Let us imagine that we have four lines of flux (4 magnetic lines of force) passing through a 5-turn coil, as illustrated in Fig. 9A. These lines of force can be produced by another coil or by a permanent magnet. (We will let straight lines represent flux, although we know that each of these

straight lines is actually a portion of a complete loop of flux.) The electrical characteristics of this coil depend both on the number of turns in the coil and on the number of lines of flux passing through the coil. For convenience, radio men use the term *flux linkage* to describe this combination of flux and turns in a coil.

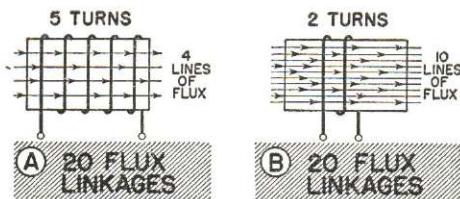
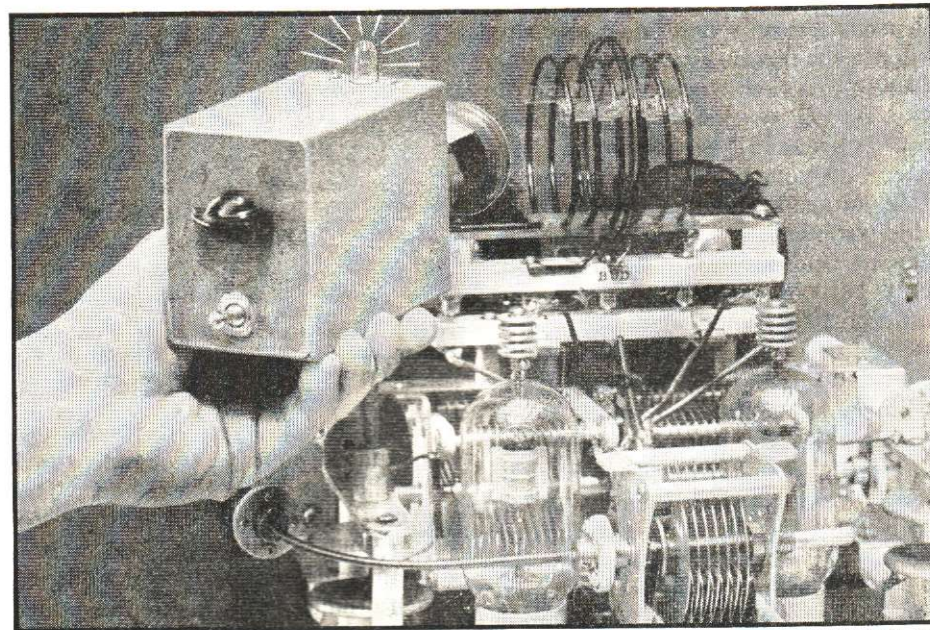

FIG. 9. Multiplying turns by lines gives flux linkages for a coil.



There are plenty of coils in this interesting view of the r.f. section of a short-wave transmitter. The transmitter coils, without cores and with plastic spacer bars instead of forms, are prominent on top of the assembly. The box with a coil projecting from its back is a wavemeter, used to determine the approximate frequency at which the transmitter is operating. The bulb on top of the box lights up when the transmitter is properly adjusted.

**Definition of Flux Linkage.** One *flux linkage* is equal to *one* line of flux passing through (linking with) *one* turn of the coil. Thus, 1 line of flux passing through 10 turns gives 10 flux linkages.

When all the flux passes through all of the turns of a coil, the total flux linkage is obtained by multiplying the number of turns in the coil by the number of magnetic lines of flux passing through all of the turns of the coil.

As an example, with our 4 lines passing through the 5 turns, we would have  $4 \times 5$ , or 20 flux linkages. Clearly, it is much easier to say "20 flux linkages" than to say "4 lines of flux passing through 5 turns."

We can get the same number of flux linkages in a number of different ways, all of which will give exactly the same result. Thus, we can get 20 flux linkages by having 10 lines of force pass-

ing through 2 turns as in Fig. 9B, because  $2 \times 10$  is 20. We can have 5 lines of force passing through 4 turns, because  $5 \times 4$  is also 20. The important thing for you to remember is that flux (lines) times turns is equal to flux linkages.

**Changing Flux Linkages.** Now imagine that we have the 5 turns shown in Fig. 9A, but we increase the number of lines of flux from 4 to 8. This increases the flux linkages from 20 to 40, because  $5 \times 8$  is 40. Whenever we increase the flux linkages of a coil in this manner, a voltage is induced in the coil, and this voltage is known as an *induced voltage*.

If we decrease the number of flux linkages in a coil, such as by changing them from 40 back to 20 or from 40 all the way down to 0, we will again have a voltage induced in the coil.

The strength of the induced voltage

depends not only upon *how much* we change the flux linkages, but also upon how long a time we take to make the change. If we change from 20 to 40 flux linkages in 1 second, we will get a certain voltage (the exact value of this voltage is not important to us in this explanation). If, however, we change from 20 to 40 flux linkages in only 1/1000 of a second, we will get exactly 1000 times as much voltage as before. The faster the rate of change in flux linkages, the greater will be the induced voltage.

There is no need to figure exact values of flux linkage in practical radio work, because we are concerned chiefly with the effects produced when flux linkages *change* from instant to instant. The one thing you *should* remember, however, is this simple induced voltage rule:

Whenever the flux linkages of a coil are *changing*, a voltage is induced in the coil.

**Lenz's Law for Coils.** The induced voltage in a coil always acts in a definite direction. This direction at any given instant depends on just two things—on the direction of the original flux, and on whether its flux linkages are increasing or decreasing.

The exact relationship between these things is expressed by a famous electrical law. It is known as Lenz's Law, because he was the first to realize that the direction in which an induced voltage acts can always be predicted beforehand. The law in its basic form is expressed as follows:

### LENZ'S LAW FOR COILS

The induced voltage always acts in such a direction that it tends to *oppose* the original change in flux linkages.

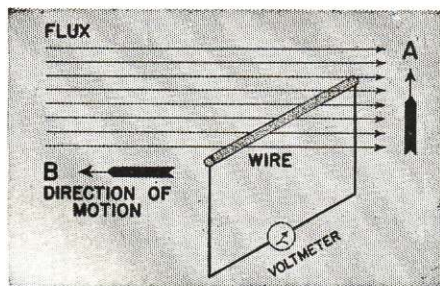

FIG. 10. Diagram illustrating how a conductor cutting across a magnetic field changes the flux linkages and gives an induced voltage.

If the flux linkages are *increasing*, the induced voltage will tend to prevent the flux from increasing. This means that the induced voltage will be in such a direction that it will tend to send through the coil a current which produces a magnetic flux which *opposes* the original coil flux. The induced voltage thus tends to prevent the increase in flux linkages.

On the other hand, if the flux linkages are *decreasing*, the induced voltage will be in such a direction that its current (when the coil circuit is complete) will produce a flux which *aids* the original flux, and thus tends to prevent the flux from *decreasing*.

### METHODS OF PRODUCING CHANGES IN FLUX LINKAGES

The three basic methods of producing changes in the flux linkages of a coil are: 1. *Cutting lines of force*; 2. *Changing the reluctance*; 3. *Changing the coil current*. Each method will now be taken up in turn, after which actual radio devices using these methods will be studied.

**1. Cutting Lines of Force.** Imagine a steady magnetic field produced by a permanent magnet or electromagnet, with a conductor (wire) located in this field and connected to a voltmeter, as shown in Fig. 10. When we move this conductor upward

through the flux in direction *A*, we induce a voltage into the conductor, and the voltmeter will indicate the presence of the voltage.

We get this induced voltage because motion of the conductor changes the flux linkages of the single-turn coil formed by the conductor and the voltmeter circuit. Moving the conductor upward, for example, *increases* the number of flux lines which are passing through the loop, thus increasing the flux linkages.

Sometimes it is easier to visualize and explain the production of an induced voltage by thinking of cutting lines of force. Whenever the conductor is moved through a line of force, it is cutting that line of force

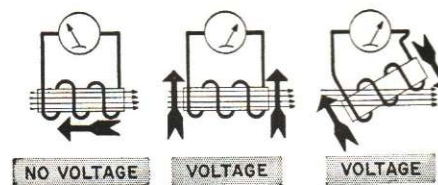

FIG. 11. FIG. 12. FIG. 13.

The large heavy arrows indicate the direction of coil motion.

momentarily, and this produces an induced voltage in the conductor.

If we move the conductor parallel to the lines of force, as indicated by direction arrow *B* in Fig. 10, however, we do not get an induced voltage. We have neither cut lines of force nor changed the amount of flux passing through the coil, hence we have not changed the flux linkages of the coil.

Exactly the same explanation applies to Fig. 11, where an entire coil is being moved parallel to lines of flux. There is no cutting of lines, no change in flux linkages, and hence no induced voltage.

When we move a coil across a magnetic field as in Fig. 12, however, we are definitely cutting lines of force

and changing the flux linkages of the coil, so we get an induced voltage.

Likewise, we cut lines of force and get an induced voltage when we rotate a coil in a magnetic field, as illustrated in Fig. 13. Here we are changing the amount of flux which passes through the various turns of the coil.

The faster we cut across lines of force with a conductor or coil, the faster we will be *changing* the flux linkages and the higher will be the induced voltage.

### 2. Changing the Reluctance.

Motion of a movable iron portion of the magnetic circuit of a coil will change the reluctance. Any change in the reluctance of the magnetic circuit will change the amount of flux which passes through the coil, thus changing the flux linkages of the coil and inducing a voltage. Remember, whenever there is a change in flux linkage, a voltage will be induced.

### 3. Changing the Coil Current.

When two coils are arranged as shown in Fig. 14, whereby the flux produced by current-carrying coil *L* passes through coil *L*<sub>1</sub>, we can induce a voltage in coil *L*<sub>1</sub> simply by changing the current through coil *L*. By changing

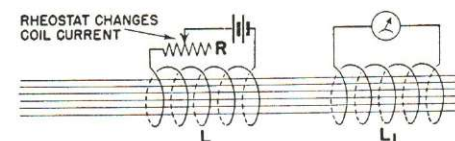

FIG. 14. This diagram shows how a change in current in one coil can induce a voltage in another coil.

the current, we change the amount of flux produced by *L*. This changes the amount of flux passing through *L*<sub>1</sub>, thereby changing its flux linkages and producing the induced voltage. The faster the current is changed, the faster the flux linkages will change and the greater will be the induced voltage.

Changes in current are usually secured in radio coil devices simply by sending alternating current through the flux-producing coil. An alternating current is varying continually in value from zero to maximum values in either direction, so it makes flux linkages change continually.

The higher the frequency, the more cycles of change there are per second and the faster is the current changing at all times. Therefore, increasing the frequency makes current, flux, and flux linkages all change faster, giving a higher induced voltage.

### EXAMPLES

The best way to *understand* (not memorize) basic radio principles is by seeing how they are applied in actual radio parts. The following examples of voltage-producing devices will therefore familiarize you with these important principles and at the same time make you acquainted with the

15A. A strong fixed magnetic field is produced by a permanent magnet inserted in the central soft iron core. Two return paths through iron, with an air gap in each one, are provided to complete the magnetic circuit of the permanent magnet from its lower end to its upper end.



Modern Dynamic Microphones

The voice coil is attached to a flexible metal diaphragm in such a way that this coil moves in and out of the flux in the air gap whenever the diaphragm is moved up and down by sound waves.

When the voice coil is at the normal at-rest position determined by the springiness of the diaphragm (Fig. 15A), only a few turns of the voice coil are in the air gap. Only a part of the total air gap flux passes through these few turns, hence the number of flux linkages is quite small. These flux linkages are constant when the coil is at rest, hence no voltage is induced in the coil.

When sound waves push the diaphragm down, the coil moves farther into the air gap, as in Fig. 15B, cutting magnetic lines of force and thus increasing the flux linkages of the voice coil. This induces a voltage in the voice coil.

When sound waves pull the diaphragm up, the coil moves out of the air gap as in Fig. 15C, cutting those lines of force which formerly were passing through some of the coil turns. Now we are *reducing* the flux linkages, and again we have an induced voltage.

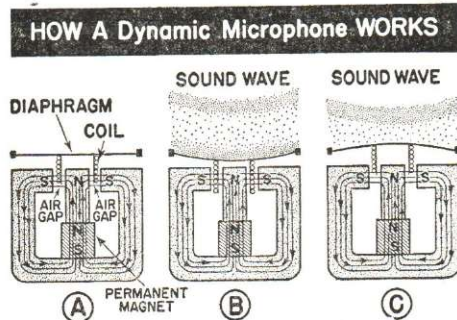

FIG. 15. Simplified cross-section views of a dynamic microphone.

construction and operation of some highly important radio parts.

**Dynamic Microphone.** This is an example of a voltage-producing radio device in which the changes in flux linkages are produced by making a coil cut magnetic lines of force.

The general construction of a dynamic microphone is shown in Fig.

The voice coil thus cuts magnetic lines of force and changes its flux linkages whenever the coil is in motion. As a result, the voltage induced in the coil is an a.f. voltage corresponding to the sound wave which causes the movements of the diaphragm and voice coil.

**Magnetic Phono Pick-up.** Here is an example of a unit which depends for its action upon a *change in reluctance*. The series of diagrams in Fig. 16 will help you to understand the construction and operation of one of these units.

This phono pick-up unit is designed for lateral-cut phonograph records, where the groove is always the same depth but wiggles from side to side in accordance with the audio signal. In following the wavy path of a groove, the phonograph needle moves from side to side. This causes the pivoted iron armature to rock back and forth between the two U-shaped soft iron pieces, one of which is on the inside of each pole of the horseshoe-shaped permanent magnet.

When the groove in the phonograph record is straight, as during a moment of silence in a recording, the pivoted armature has the mid-position shown in Fig. 16A. Flux now divides about equally over the two paths from the N poles to the S poles because both paths have about the same reluctance, and there is essentially no flux traveling vertically through the armature. As a result, there is no flux passing through the coil and no flux linkages in the coil.

When the needle tilts the armature to one side, as shown in Fig. 16B, the lowest-reluctance path is that shown by the dotted arrows in this diagram. The farther the top of the armature tilts to the left, the lower becomes the reluctance and the more flux flows through the armature. This

changing flux induces a voltage in the coil which surrounds the armature. The flux is changing continually because the phonograph needle is moving continually from side to side as it rides in the groove.

When the needle tilts the armature the other way, the flux will travel in the opposite direction through the armature, as indicated in Fig. 16C

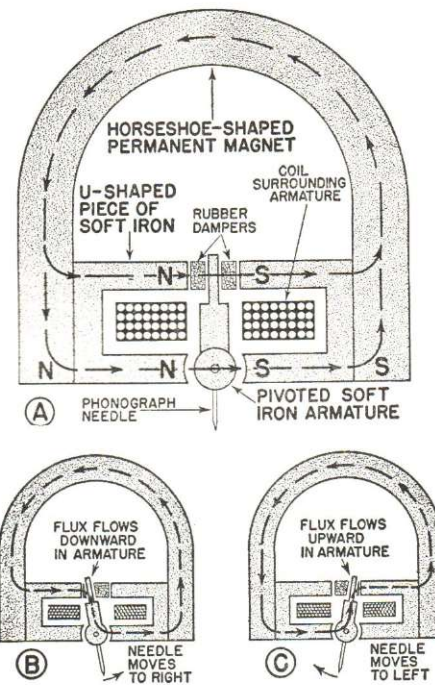
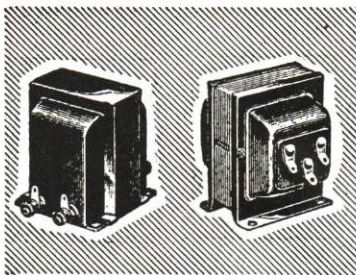

FIG. 16. Cross-section views illustrating the basic operating principles of a magnetic phono pick-up.

When the needle moves continually back and forth between the positions of Figs. 16B and 16C during the playing of a record, the continually varying and reversing flux in the armature and in the coil keeps the flux linkages of the coil changing continually, thereby inducing in the coil an a.f. voltage corresponding to the sounds recorded on the phonograph record.

Rubber dampers prevent the top of the armature from "sticking" in any





**A.F. TRANSFORMERS**

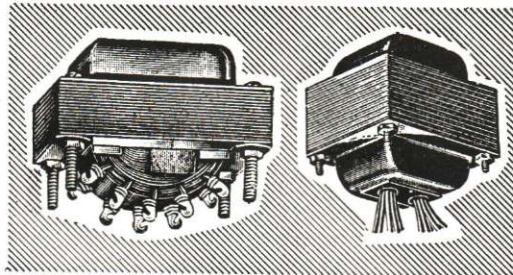

**POWER TRANSFORMERS**

Examples of iron-core transformers you will encounter in radio receivers.

one position, and also prevent it from vibrating too greatly under certain conditions.

**Transformer.** The best-known example of a radio part in which changes in flux linkages are secured by changing the coil current is the *transformer*. The basic construction of one type of transformer, an iron-core unit, is shown in Fig. 17 to illustrate the basic principles involved.

Two coils are wound around the central part of the iron core. These coils could be placed side by side as shown in the diagram. In actual units, however, one is usually wound over the other, with insulating cloth between, because this gives lower manufacturing costs without affecting performance.

The winding through which we send the current from our voltage source is called the *primary winding*, and is usually marked PRI. or P. The other winding, in which the voltage is induced, is called the *secondary winding* and is usually marked SEC. or S. A transformer will have only one primary winding, but can have any number of secondary windings.

When steady direct current is sent through the primary winding, this current produces magnetic lines of force which take the paths shown in Fig. 17. This flux passes through the secondary winding and gives it a definite num-

ber of flux linkages. With direct current, however, the number of flux linkages does not change, and hence no voltage is induced in the secondary winding.

Whenever we change the value of the primary current, the flux in the iron core changes accordingly, and hence the flux linkages of the secondary winding change. As a result, a voltage is induced in the secondary whenever the primary current changes.

When an alternating current is sent through the primary, we have a continually varying primary current and correspondingly varying flux linkages in the secondary winding. The voltage induced in the secondary under this condition is an a.c. voltage of the same frequency. A transformer thus transfers an a.c. voltage from one circuit to another without wire connections.

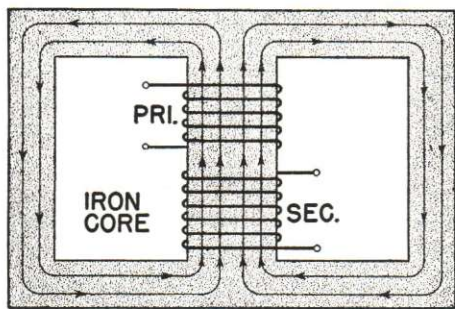

FIG. 17. This diagram illustrates the basic principles of an iron-core transformer. Arrow lines indicate paths taken by magnetic flux.

## Basic Idea of Inductance

**Self-Induced Voltage.** Up to the present time, we have studied what happened when coils were placed in magnetic fields produced by other devices. However, a coil can be entirely by itself, far away from other magnetic fields, and still have an induced voltage. Here is how this "self-induced" voltage is produced.

When current is sent through a single coil, the coil produces its own magnetic field. And when this coil current changes, due to a change in the applied voltage, the magnetic field also changes in strength. Naturally, this magnetic field links with the coil, so we have changing flux linkages in the coil. This means that there is an induced voltage in the coil, produced by the coil itself and hence called a *self-induced voltage*. Lenz's Law says that this *self-induced voltage* must be in such a direction that it *opposes* the original change.

As an example, when we increase the coil current by boosting the applied voltage, we get an induced voltage which opposes the applied voltage and thus opposes the increase in applied voltage. The important thing for you to realize is that the induced voltage always *opposes* the *change* which is producing the induced voltage. If we didn't have this natural opposition to changes—if instead the induced voltage aided the change—then the induced voltage would build up to tremendously high values and destroy the coil.

**Inductance.** The characteristic which determines how much voltage will be induced in a coil by a given change in current is called *inductance*. Inductance is one factor which determines how much the self-induced voltage will be. More specifically,

the electrical size or inductance of a coil determines how much *change* in flux linkages will be obtained with a given change in coil current. The higher the inductance, the greater will be the change in flux linkages for a given current change.

**Units of Inductance.** The basic unit of inductance is the *henry*. It is named after Professor Joseph Henry, an outstanding American scientist who announced the results of his coil experiments in 1832. The henry specifies the amount of flux linkages produced by an ampere of current. If one ampere produces 100,000,000 flux linkages in an air-core coil, the coil has an inductance of *one henry*.

All coils, including iron-core coils, are said to have an inductance of one henry when a current change of one

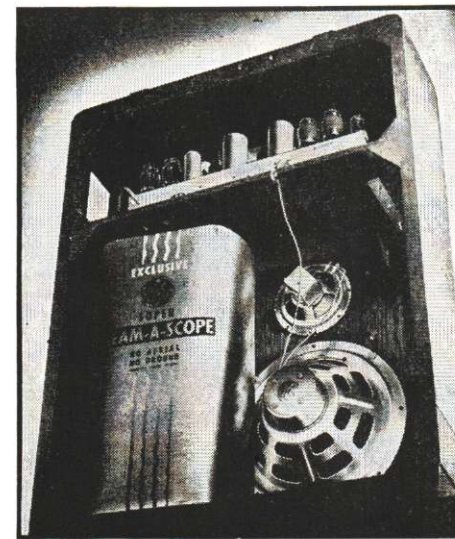

Courtesy General Electric Co.

Inside the cardboard housing of the "Beam-A-Scope" in this General Electric console receiver is a large coil which serves as a built-in loop antenna. The three cylindrical shield cans on top of the chassis contain r.f. and i.f. coils, and the two loudspeakers have iron-core coils.

ampere in one second produces a self-induced voltage of one volt.

Although some of the iron-core coils used in radio have inductance values ranging as high as 1000 henrys, air-core radio coils have inductance values of only a small fraction of a henry. For convenience in specifying inductance values of air-core coils and small iron-core coils, we frequently use another unit of inductance called the *millihenry*. One millihenry is equal to one-thousandth of a henry, hence there are 1000 millihenrys in one henry. Here are some examples: 500 millihenrys is equal to .5 henry; 9000 millihenrys is equal to 9 henrys.

A still smaller unit of inductance occasionally encountered in radio is the *microhenry*. It is equal to one-millionth of a henry. It takes one thousand microhenrys to make one millihenry.

#### Factors Affecting Inductance.

The inductance of a coil is determined by the number of turns in the coil, by the shape of the coil, and by the material used in the core of the coil. It is possible to calculate by means of formulas the inductance which will be obtained with any combination of these factors, but practical radio men do not particularly need to know such design procedures.

It is entirely sufficient to know that when you increase the number of turns in a coil, the inductance will increase likewise. If you reduce the number of turns, the inductance will go down. Furthermore, the change in inductance will be somewhat faster than the change in turns.

It should be pointed out that inductance is not necessarily limited to coils. Even a straight wire has inductance; in fact, straight wires or straight pipes are actually used as in-

ductances in ultra-high-frequency equipment. The inductance value is too small for the type of radio receivers we use in our homes, but becomes effective and useful at ultra-high frequencies.

#### A. C. Voltage Drop of a Coil.

We have learned that whenever the flux linkages of a coil are changed in any way, a voltage is induced in the coil. Therefore, if we send alternating current through a single coil, the continually changing flux linkages will cause an a.c. voltage to be induced in the coil itself.

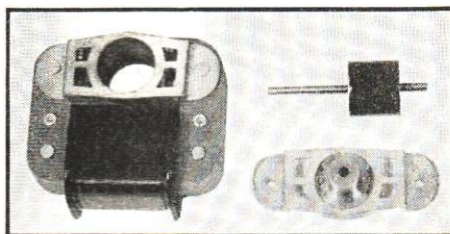

Courtesy Barber-Colman Co.

A single coil wound on an iron core provides the varying magnetic field which operates this small a.c. motor, used to drive the magnetic tuning unit of a radio receiver. The "squirrel-cage" armature at the upper right fits into the hole above the coil, being supported there by two bearing assemblies like that shown at the lower right.

Since an induced voltage always opposes whatever force is producing it, a self-induced a.c. voltage in a coil opposes the a.c. source voltage. This is why a self-induced voltage is sometimes known as a *back e.m.f.* or *counter e.m.f.*

The back e.m.f. in a coil is the a.c. voltage drop appearing across the coil. Just as the voltage drop across a resistor is due to current flowing through the opposition in ohms of a resistor, so is the a.c. voltage drop (back e.m.f.) of a coil due to the opposition in ohms which the coil offers to alternating current. This coil opposition is known



Courtesy Henry L. Crowley & Co., Inc.

These two molded cup-shaped outer pieces and the cylindrical iron core of pulverized iron will, when assembled, form a complete magnetic core for the r.f. choke coil, greatly increasing its inductance.

as *inductive reactance*, and is well worth thorough study now because it determines how much alternating current will flow through a coil in a particular radio circuit.

**Inductive Reactance.** The opposition in ohms which a coil offers to the flow of alternating current varies with frequency. This explains why the frequency value is included in the following rule for figuring the inductive reactance of a coil:

*The inductive reactance in ohms of a coil is equal to the inductance of the coil in henrys multiplied by 6.28 times the frequency in cycles.*

By using letter notations for some of these terms, we can express this relationship more conveniently by an equation or formula. The notation  $X_L$  is used to represent inductive reactance. The smaller letter  $f$  is used to represent frequency. The letter  $L$  is used in formulas to represent inductance. With these notations, the inductive reactance in ohms of a coil can be expressed by means of the following formula:

$$X_L = 6.28 \times f \times L$$

You will occasionally find this formula written as  $X_L = 2\pi fL$ ;  $\pi$  is the

Greek letter pi (pronounced *pie*) which is commonly used to represent the mathematical number 3.14, and  $2\pi$  is  $2 \times 3.14$ , or 6.28, the number in our first formula.

*Example:* Suppose we wanted to know the inductive reactance of a 30-henry choke coil at 120 cycles. The formula is:

$$X_L = 6.28 \times f \times L$$

Substituting 120 for  $f$  and 30 for  $L$  gives

$$X_L = 6.28 \times 120 \times 30$$

Multiplying these three numbers together gives 22,608 as the value of  $X_L$ . This coil would therefore have an opposition (inductive reactance) of about 22,600 ohms in a 120-cycle alternating current circuit.

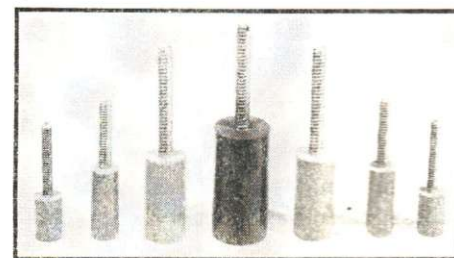

Courtesy Henry L. Crowley & Co., Inc.

Examples of pulverized iron cores used in adjustable r.f. coils. Each screw is slotted at the end for adjusting purposes; rotating the screw with a screwdriver moves the core into or out of the coil, thereby changing the inductance. This method of changing the inductance of a coil is often called permeability tuning.

At 60 cycles, the inductive reactance of this coil would be  $6.28 \times 60 \times 30$ , or 11,300 ohms, which is exactly half the reactance at 120 cycles. At 120,000 cycles, the inductive reactance would be  $6.28 \times 120,000 \times 30$ , or 22,600,000 ohms. Inductive reactance thus varies directly with frequency. These examples are given not because you will solve such problems as a technician, but to show you how reactance varies with frequency, and to show

that the reactance also varies with the inductance of a coil.

Just as a matter of comparison, we might point out that in a direct current circuit, the only opposition this 30-henry coil would offer to the flow of current would be that due to the resistance of the copper wire in the coil—about 400 ohms for a coil of this size. This d.c. resistance will also affect alternating current, and will produce an a.c. voltage drop. This resistance value is negligibly small in comparison to the 22,600-ohm inductive reactance at 120 cycles, so we normally neglect the a.c. voltage drop due to the resistance of the coil.

**Ohm's Law for Coils.** Ohm's Law tells us how much alternating current will flow through a particular coil under given conditions, just as it does for resistors in direct current circuits. We need to know only the inductive reactance of the coil in ohms and the effective value of the a.c. voltage applied to the coil. The effective alternating current value in amperes is then equal to the a.c. voltage in volts divided by the reactance in ohms. (This assumes that the d.c. resistance of the coil is negligibly small in comparison to its reactance.)

The simple formula is  $I = E \div X_L$ ; you will recognize this as being very similar to  $I = E \div R$ , the d.c. version of this Ohm's Law formula.

*Example:* A coil having a reactance of 6000 ohms is to be connected across a 120-volt a.c. power line. What current will flow through the coil?

Since  $I$  is equal to  $E \div X_L$ , we divide 120 by 6000, and get .02 ampere as the a.c. coil current.

The other two Ohm's Law formulas for coils having negligibly small resistance are  $E = I \times X_L$  (for use when you want to figure the a.c. voltage drop across a coil) and  $X_L = E \div I$  (for use when you want to

figure the inductive reactance of a coil).

**Mutually Coupled Coils.** When the two coils of a transformer are wound side by side or one over the other on a paper or fiber form, without any magnetic material in the core, we have an *air-core transformer*, and the two coils are mutually coupled through their magnetic fields. Air-core units are usually called *r.f. transformers* or *i.f. transformers*, because they are used chiefly in radio fre-

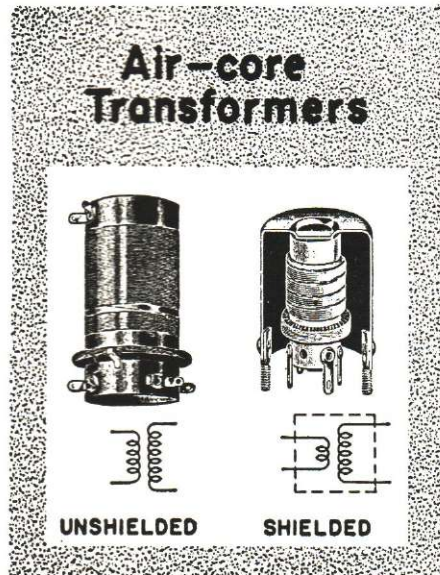

quency (r. f.) and intermediate frequency (i.f.) circuits.

Radio men often speak of *r.f. coils* when they mean *r.f. transformers*. An r.f. transformer does consist of two or more r.f. coils, so there is some justification for this. Anyway, the terms are a part of the radio man's everyday language, so we might as well accept them.

In two coils which are mutually coupled, the voltage induced in the second coil depends on three things: 1. The *frequency* of the primary cur-

rent; 2. The *effective value* of the primary current; 3. The *mutual inductance* of the two coils. Increasing any one of these three things will increase the induced voltage in the secondary, as explained later.

*Effect of Frequency.* The higher the frequency of the primary current, the faster will the flux be changing and the greater will be the induced voltage in the secondary.

*Effect of Current.* The higher the value of primary current, the more flux it will produce. Since this flux varies from a maximum value in one direction to zero and then to a maximum in the other direction, more flux means a greater change in flux per unit of time and a higher induced voltage in the secondary.

*Mutual Inductance.* This is a factor which expresses in a practical manner the amount of coupling (flux linkage) between the primary and secondary coils of an air-core transformer. The greater the mutual inductance value, the greater will be the voltage induced in the secondary of the transformer by a given change in primary current.

Mutual inductance depends upon the sizes of both air-core coils, the number of turns on each coil, their relative positions and their distances apart.

Mutual inductance is specified in henrys just like ordinary inductance, and is represented in formulas by the letter  $M$ . The higher the value of mutual inductance, the greater will be the induced voltage in the secondary coil.

Sometimes you will find mutual inductance defined as follows: When a change of one ampere per second in primary current produces one volt in the secondary, the mutual inductance is one henry. This applies to any mutually-coupled coil.

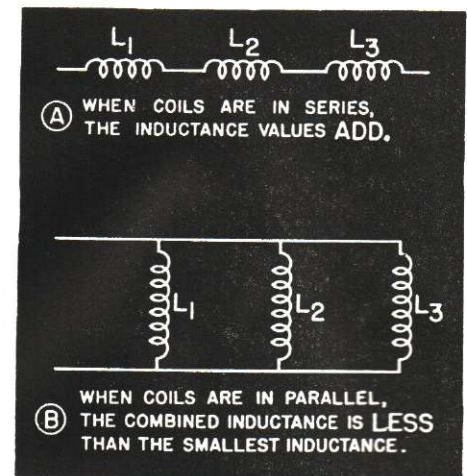

FIG. 18. Coils combine exactly like resistors.

### COILS IN SERIES AND PARALLEL

It is worth knowing in a general manner what happens when coils are combined in series or in parallel, the coils being far enough apart so that their magnetic fields do not affect each other, or shields being used to prevent interaction of the coils.

When coils are connected together in series, as shown in Fig. 18A, the combined inductance is the *sum* of the individual inductances.

When coils are connected together in parallel, as shown in Fig. 18B, the combined inductance is *less than* the smallest inductance in the group.

These rules for combinations of coils are exactly the same as for combina-

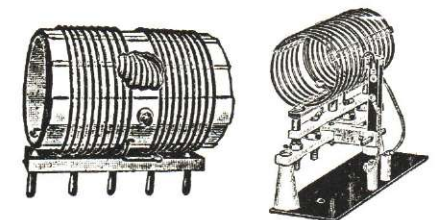

Air-core transformers for short-wave transmitters. The amount of coupling between the two coils is varied in the left-hand unit by rotating a small inner coil, and in the right-hand unit by moving a link (one or two-turn coil) between the two coils.

tions of resistors. This fact makes it easy for you to remember how coils combine.

### Mutually-Coupled Coils in Series.

When two coils are connected in series and are close enough together so that mutual inductance exists, we have interaction between the coils, and the combined inductance will be either increased or decreased by a factor equal to twice the value of the mutual inductance in henrys. Thus, if coil connections are such that the magnetic fields of the two coils aid each other, the combined inductance will be equal to  $L_1 + L_2 + 2M$ . If the connections are such that the magnetic fields of the two coils oppose each other, the combined inductance will be  $L_1 + L_2$

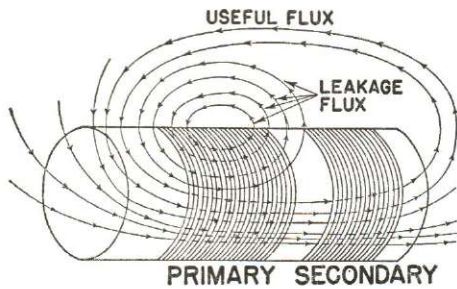

FIG. 19. Leakage flux. In the average coil, the leakage flux is only a small proportion of the total useful flux.

—  $2M$ . Reversing the connections to one of the coils will reverse the effect of the mutual inductance factor.

**Leakage Flux.** Flux which is produced by the primary winding of a transformer but does not produce the maximum possible number of flux linkages with the secondary winding is called *leakage flux*. Two mutually-coupled air-core coils do not give the maximum possible transfer of voltage from primary to secondary because of this leakage flux.

In a single coil by itself, the flux which is produced by some of the turns but does not link with all of the

turns of the coil is called *leakage flux*. This is basically the reason why certain shapes and sizes of coils give greater inductance for a given length of wire.

The name leakage flux is used because this flux "leaks" back around a path whereby it does not do its full quota of useful work. Examples of both types of flux are shown in Fig. 19. You will frequently encounter the subject of leakage flux as you continue your study of radio.

## VARIABLE INDUCTANCES

In some receiver and transmitter circuits, it is necessary to provide means for changing the inductance value of the coil in a radio circuit. Thus, in receivers having more than one band, different inductance values are needed for each band. This can be done in a number of different ways, which we will now consider, one at a time.

**Changing Entire Coils.** One way to change quickly from one inductance value to another is by means of plug-in coils, which fit into sockets in the chassis and can be changed just like tubes are changed. Plug-in coils are used today chiefly in experimental receivers, communications receivers and transmitters, for band-changing purposes so as to permit reception or transmitter operation in a particular band of frequencies.

A more convenient way of changing coils, used in many modern all-wave



Examples of plug-in coils used in experimental short-wave receivers.

receivers and communication transmitters, is by means of a band-changing switch which disconnects one set of coils completely and connects another set in its place when the switch knob is rotated. Sometimes the coils are provided with taps, and the band-changing switch makes connections to the taps which place the desired numbers of turns in the circuits.

**Variometers.** The inductance of a coil can be varied gradually between two values with a *variometer*. This is simply a variable inductance in which one coil is rotated inside a larger coil. The two coils are connected in series. Rotation of the inside coil changes the amount of coupling between the two coils, changing the mutual inductance of the two coils and thus changing their combined in-

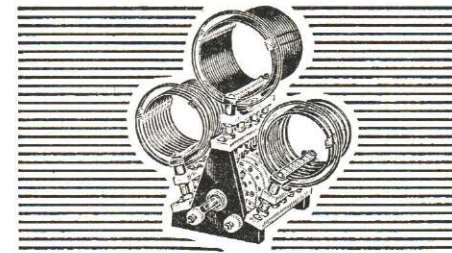

Transmitter band-switching arrangement which makes it possible to connect any one of three coils into the circuit merely by turning the switch. Many all-wave receivers have similar band-switching arrangements, using smaller coils and more compact switches.

ductance. Variometers were once widely used in receivers for tuning purposes, and are still to be found in some types of radio transmitters.

**Permeability Tuning.** The inductance of a coil can be varied by moving a small cylindrical core of pulverized iron into or out of the coil. This varies the reluctance of the magnetic circuit of the coil, which changes the amount of flux the coil can produce, and thus varies the inductance.

This method of varying inductance

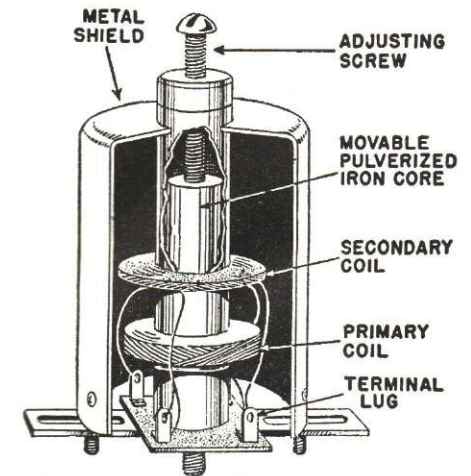

R.F. transformer with adjustable pulverized iron core. Tightening the adjusting screw raises the core out of the primary coil, thereby reducing the amount of coupling between the two coils.

is usually known as *permeability tuning*, because as we include more of the iron in the magnetic path of the coil we change the permeability of the magnetic path. Some modern receivers are now using variable inductances like this with fixed condensers for tuning purposes, in place of variable condensers with fixed inductances.

## RESISTANCE OF A COIL

When a coil is connected to a d.c. voltage source, direct current flows through the coil. The value of this steady direct current depends only on the *d.c. resistance* of the coil, which is simply the resistance of the copper wire used in constructing the coil. (The inductive reactance of the coil has no effect whatsoever on the amount of direct current which flows through the coil, as reactance exists and offers opposition only in a.c. circuits.)

Although copper wire has a lower resistance per unit length and thickness than almost any other material you encounter in radio, coils are sometimes made with so much fine copper

wire that they have d.c. resistance values even higher than 1000 ohms. On the other hand, some coils are made from only a few turns of large wire, so their d.c. resistance is considerably less than 1 ohm.

A knowledge of d.c. resistance values of coils is extremely useful when hunting for trouble in radio equipment. Just by comparing the measured d.c. resistance of a coil with the value specified on the circuit diagram, you

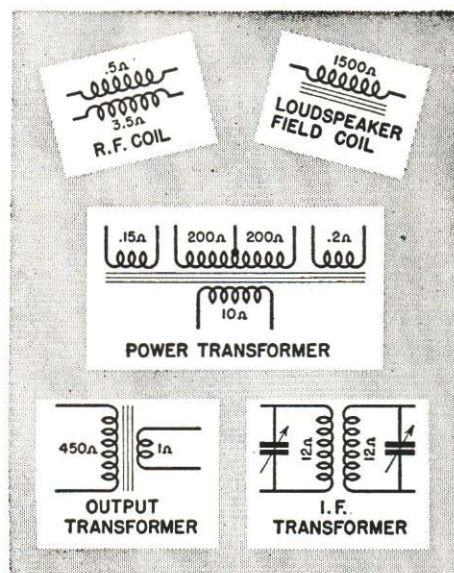

FIG. 20. The d.c. resistance values of coils are often given on circuit diagrams of radio receivers, much in the manner shown here.

may be able to tell whether or not a coil is defective.

You will often find resistance values specified near the coil symbols on circuit diagrams, much in the manner shown in Fig. 20 for typical coils of different types. This information is particularly useful when checking resistance or continuity in a circuit with an ohmmeter in order to locate a defective part, as you will learn when you begin mastering radio servicing techniques.

Another practical use for d.c. resistance values of coils is in identifying the coils in the various bands of an all-wave receiver. Coils for short-wave bands always have less inductance than broadcast band coils. This means that short-wave coils have fewer turns, less wire and less resistance. The tuning coil having the lowest resistance can therefore be identified as belonging to the lowest short-wave band (the highest-frequency band). The tuning coil having the most resistance will belong to the broadcast band.

**Using Ohm's Law.** A coil in a direct current circuit acts exactly like a resistance insofar as the d.c. voltage source is concerned. This means you can use Ohm's Law to figure voltage, current and resistance values for coils in d.c. circuits, just as you do for resistors. For example, to figure the amount of direct current which will flow through a coil, you divide the d.c. voltage applied to the coil by the d.c. resistance of the coil ( $I = E \div R$ ).

**Coils Can Get Hot.** In the previous lesson, you learned that whenever current flows through a resistance, heat is produced. The copper wire in a coil has resistance, and therefore heats up exactly like a resistor. If you overload a coil by sending too much direct current through it, the wire in the coil melts and burns out just like an overloaded wire-wound resistor. When coils are sealed with pitch, as is the case in some output transformers and filter chokes, overloading may melt the sealing compound, causing smoke and a characteristic burned odor.

**Magnet Wire.** Coils are usually wound with one or more layers of insulated copper wire. You will find three types of insulation in common use—enamel, cotton and silk, used singly or in combinations like silk

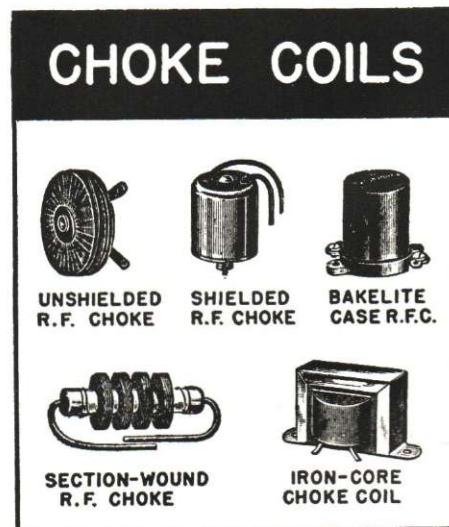

Examples of choke coils you will encounter in radio receivers and transmitters. Single coils by themselves are called choke coils by radio men, and are used individually in radio circuits to offer opposition to alternating current without appreciably hindering the flow of direct current. Basket-weave windings (like that of the unshielded r.f. choke) and criss-cross windings give low distributed capacity (explained later), thereby improving the effectiveness of the coil at high radio frequencies.

over enamel and cotton over enamel. Wire in the sizes and types used for coils is popularly known as *magnet wire*, because at one time such wire was used chiefly for electromagnets.

Coils are sometimes baked in a hot oven during manufacture to drive off moisture, then dipped in insulating varnish or molten wax to make them moisture-proof and to hold the turns of wire in position despite rough handling.

### NON-INDUCTIVE RESISTORS

Wire-wound resistors made by winding nichrome resistance wire around an insulating form are really small coils having high resistance. Oftentimes, the coil characteristics of these wire-wound resistors are highly undesirable. This is particularly true

in the high frequency radio circuits used in frequency modulation receivers and transmitters, in television receivers and transmitters, in ultra-high frequency police radio equipment, and in radio airplane locators. For these circuits we must use non-inductive resistors, which have no coil characteristics.

Carbon and metallized resistors are considered as non-inductive resistors, for each one is a single straight rod without any turns or coils, having negligible inductance.

Special windings are used on wire-wound resistors to get non-inductive characteristics. One example is the so-called "hairpin-type winding" shown in Fig. 21A. In this winding,

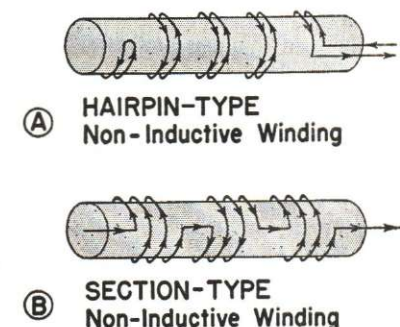

FIG. 21. Two ways of winding wire-wound resistors so they have practically no inductive characteristics. Arrows indicate directions of electron flow.

the electron flow is in opposite directions through any two adjacent wires, hence the magnetic fields produced by the adjacent wires are in opposite directions and cancel each other. The result is zero inductance.

Another type of non-inductive winding is shown in Fig. 21B. Here the resistor is made of an even number of sections, connected so current flows in opposite directions through adjacent sections. The magnetic fields of adjacent sections cancel each other, and again we have zero inductance.

# Simple Coil-Resistor Circuit

We have already seen that when a coil alone is connected to an a.c. voltage source, its reactance determines what current will flow. We now come to a practical case where a coil is used in series with a resistor in an a.c. series circuit.

If we connect a coil and a lamp in series to a 115-volt d.c. source, as in Fig. 22A, then connect d.c. voltmeters to measure the voltage drops across the coil and lamp, we will find that these voltages check with Kirchhoff's Voltage Law. In other words, the voltage drops will add up to 115 volts, the source voltage.

Suppose, however, that we change to a 115-volt a.c. source, as in Fig. 22B. With a.c. voltmeters being used now to measure the voltage drops, we find that the two voltage drops add up to 154 volts, which is much higher than the source voltage. Clearly, we cannot apply Kirchhoff's Voltage Law directly to a.c. circuits.

We know this law must hold true because it is a fundamental radio law, so let us now see *why* it doesn't apply directly. Let us also investigate the special procedure a radio design engineer might have to use in order to make the law apply. This problem brings us for the first time to the subject of *phase*.

**Phase.** The voltage drops across the coil and lamp in Fig. 22B do not add up to the a.c. source voltage because these a.c. voltage drops do not reach corresponding peak values at the same instant of time in each cycle. In other words, one a.c. voltage may be at the zero point in its cycle at the instant when the other a.c. voltage is at its maximum or peak value. We encounter this situation whenever we use coils or condensers along with resistors in radio circuits, and we say

that there is a *phase difference* between these a.c. voltage drops.

The only time we can add directly the a.c. voltages which a.c. meters measure is when these voltages are in phase with each other (when all reach corresponding peak values in each cycle at the same instant of time, and all drop to zero together). This occurs only when all the parts in the circuit are identical (all are resistors, all are perfect coils or all are condensers). Let us see how phase enters into the picture when we use a coil in an a.c. circuit.

First of all, we can definitely say that the same value of alternating current flows through both the coil and the lamp in our a.c. circuit of

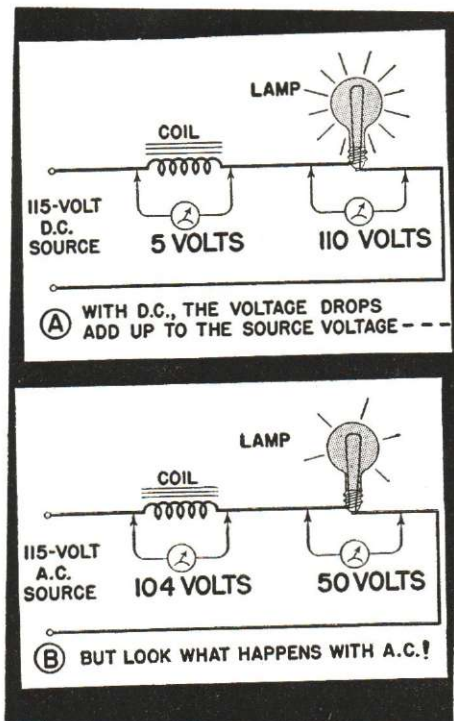

FIG. 22. Circuits illustrating the effects of phase in a.c. coil circuits.

Fig. 22B, because these two parts are in series. The curve in Fig. 23A shows how this current varies during each complete cycle. On diagrams of this type, time is always assumed to be zero at the extreme left of the curve, so the beginning of the cycle is at the left on the diagram. Time therefore increases to the right, and the end of the cycle is at the right.

A lamp is a resistance, so this current produces across the lamp an a.c. voltage drop which is *in phase* with the current. The resistor voltage curve is shown in Fig. 23B for the same interval of time covered by the current curve in Fig. 23A. Compare these two curves, and you will see that voltage and current values for a resistor reach corresponding peak values in each cycle at exactly the same instant of time.

The a.c. voltage across the coil is definitely not in phase with the circuit current. Technically speaking, the

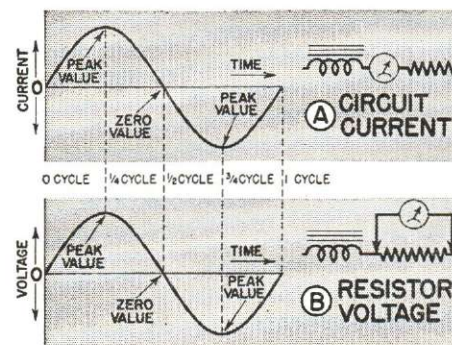

FIG. 23. These two curves show that voltage and current values for a resistor reach corresponding values at exactly the same instant of time. This means that voltage and current for a resistor are **IN PHASE** with each other.

current in a perfect coil always *lags* the coil voltage by 90° (one-quarter cycle). The reason for this can be explained in a few sentences, with the aid of the circuit current curve in Fig. 24A.

First of all, we must remember that the a.c. voltage drop of a coil depends upon how fast the coil current is changing.

Examining the current curve in Fig. 24A, we see that the current changes

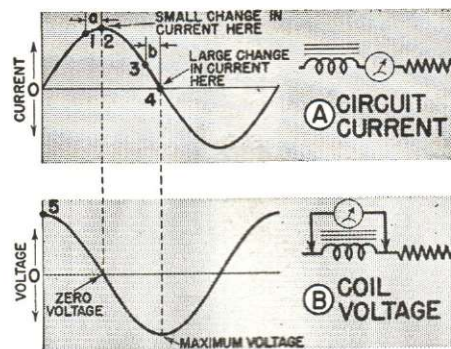

FIG. 24. The basic fact that a coil voltage is **OUT OF PHASE** with the coil current is shown by these two curves.

very little—hardly at all—during time interval *a*. The current on this diagram is represented by the distance a point on the curve is from the horizontal reference line. Since points 1 and 2 are both almost the same distance above this line, the current is essentially the same at 2, the end of time interval *a*, as at the beginning (1). When the current doesn't change, the flux doesn't change, and hence the flux linkages do not change. No changes in flux linkages mean no induced voltage to act on an a.c. voltmeter connected across the coil, which explains why we find the coil voltage to be zero when we trace downward from point 2 to the coil voltage curve in Fig. 24B.

At time interval *b* (Fig. 24A), however, the current is changing very rapidly (it drops from the value at point 3 all the way down to zero at point 4).

The steeper (more vertical) the curve, the more change there is in current during a given interval of time. We therefore expect the a.c.



olution is one cycle or  $360^\circ$ , so  $90^\circ$  will be one-quarter of a revolution. We must go one-quarter cycle counter-clockwise to get ahead  $90^\circ$ , so we draw coil voltage vector  $V_L$  straight up from  $O$ , as in Fig. 26A. Coil voltage and current vectors  $90^\circ$  apart like this would be obtained for any perfect coil in any a.c. circuit.

Only one voltage remains to be placed on our vector diagram—the source voltage. And now we learn the secret of making Kirchhoff's Voltage Law apply to our a.c. circuit: If we take the *vector sum* of the voltage drops, they will add up to the source voltage  $E$ .

To get the vector sum of voltage drops  $V_L$  and  $V_R$  on our diagram in Fig. 26B, we simply draw in dotted lines to complete a rectangle, then draw the diagonal of this rectangle from  $O$ . This diagonal line is the vector sum of the coil and resistor voltage drops, and is also equal to the source voltage, so we place an arrow on its other end and label it  $E$ . Since this vector is ahead of current vector  $I$  (remember that we have assumed counter-clockwise rotation), we say that source voltage  $E$  *leads* the circuit current. If we prefer to express it the other way, we would say that the current  $I$  *lags* the source voltage.

If we made the lengths of the voltage vectors in Fig. 26B proportional to the actual effective a.c. voltage values (for instance, if we let each inch of length along the vector represent a definite amount of voltage), then measured the length of voltage vector  $E$  in Fig. 26B and converted it back to volts, we would find that it was exactly equal to the source voltage value. Kirchhoff's Voltage Law holds true for all a.c. circuits if we apply it

in this way so as to take phase into account.

The vector diagram in Fig. 26B thus tells us the complete story about voltage and current relationships in our coil-resistor circuit shown in Figs. 22B and 26B.

**Importance of Phase.** A general knowledge of phase and vector diagrams will help you to understand the actions of coils and condensers in a.c. radio circuits, and will make you a better-than-average radio man. You will understand *why* you do certain things when making adjustments or repairs, instead of just blindly following instructions. It is the men who know *why* and *how* who command the highest salaries in the modern world of radio.

Later in your course, you will learn that the opposition of a coil can be balanced or cancelled by the opposition of a condenser because of *phase*; you will find that hum can be balanced out of a receiver because of *phase*; pictures are black when they should be white in television receivers because of *phase*; radio beacons guide aircraft in the skies because the designer took account of *phase* among other things; and so the examples pile up. Phase, however, is not a subject which you can grasp in one lesson; you will understand it better and better with each succeeding lesson.

### LOOKING AHEAD

You have now finished your study of the basic facts about resistors and coils. When you complete a similar study of condensers in the next lesson, you will have secured a thorough basic knowledge of these three important radio parts.

## Lesson Questions

Be sure to number your Answer Sheet 6FR-3.

Place your Student Number on every Answer Sheet.

Send in your set of answers for this lesson immediately after you finish them, as instructed in the Study Schedule. This will give you the greatest possible benefit from our speedy personal grading service.

- What effect does an increase in the number of ampere-turns have on the amount of magnetic flux produced by a coil?  
*AMPERE TURNS THE MORE THE FLUX THROUGH THE MAGNETIC*
- Copy the following list on your Answer Sheet, and indicate after each material whether it is magnetic or non-magnetic.
 

(a) Copper.	<i>NON-MAGNETIC</i>	Examples (do not copy these):
(b) Sheet steel.	<i>MAGNETIC</i>	(x) Brass. Non-magnetic.
(c) Plywood.	<i>NON-MAGNETIC</i>	(y) Air. Non-magnetic.
(d) Aluminum.	<i>NON-MAGNETIC</i>	(z) Alnico alloy. Magnetic.
(e) Cast iron.	<i>MAGNETIC</i>	
- When a pivoted iron object takes the position which gives minimum reluctance to the magnetic circuit of a coil, will we get *maximum flux* or *minimum flux*?  
*MAXIMUM FLUX*
- How many flux linkages do we have when 25,000 magnetic lines of force pass through a 3-turn coil?  
*3 x 25,000 = 75,000*
- Will we get an induced voltage if we suddenly reduce the number of flux linkages in a coil?
- Is any voltage induced in a coil when the flux linkages are not changing?  
*NO*
- Why do we get an induced voltage in a current-carrying coil when we change the reluctance of the magnetic circuit of the coil?
- If a coil has an inductance of 2 henrys, what is its inductance in millihenrys?  
*2000 mH*
- Is the inductive reactance of a coil the same at all frequencies?  
*NO*
- How many degrees out of phase with each other are the voltage and current in a perfect coil?  
*90°*





## SINCERE APPRECIATION PAYS

Have you ever watched a dog respond to a friendly pat as a reward for obedience? Have you noticed how a child glows with joy when praised for good behavior? Have you ever felt your own brain cells respond with increased effort when you praise them by saying, "*That's a fine piece of work, even if I did do it myself!*"?

Yes, everyone responds to sincere and merited praise. It is a tonic to both giver and receiver. It brings greater praise and appreciation back to you. It costs nothing more than a smile and a few sincere words, but it can truly achieve miracles in happiness and success, and put real money in your pocket.

Time spent in figuring how to give sincere and deserved praise is well worth while. Let people know that you appreciate *their* fine work, and watch the breaks come *your way*.

*J.E. Smith*