

PRACTICAL ELECTRONIC CONTROL EQUIPMENT

REFERENCE TEXT 64RX

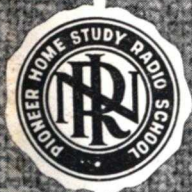

NATIONAL RADIO INSTITUTE

WASHINGTON, D. C.

ESTABLISHED 1914

PROPHECIES

Training in a new and specialized field like Electronic Control is peculiar in that it prepares you to be a better man in your chosen profession rather than for a new job in a new field. Later, when Electronic Control assumes its rightful position of importance alongside the other professions, you will be ready. Study and experience will gradually make you an expert, and a steadily increasing reputation for ability can very easily build up your business to the point where you will be able to devote full time to Electronic Control jobs, should you so desire.

This reference book and the preceding books dealing with electronic subjects together give you a thorough knowledge of the basic ideas—the fundamental principles of practical electronic control equipment. In the near future you will recognize these books as among the most important you have ever studied—that you will refer to them continually, regardless of what your field of endeavor may be.

In the years to come, the electronic control systems which today appear as miracles to the uninitiated public will form the very backbone of our civilization—of an electronic civilization in which man's ingenuity will bring about greater happiness, better health, more comfort and more leisure to mankind.

A LESSON TEXT OF THE N. R. I. COURSE
WHICH TRAINS YOU TO BECOME A
RADIOTRICIAN & TELETRICIAN
(REGISTERED U. S. PATENT OFFICE) (REGISTERED U. S. PATENT OFFICE)

COPYRIGHT 1947 BY NATIONAL ELECTRONICS INSTITUTE, INC., WASHINGTON, D. C.

(An affiliate of the National Radio Institute)

FM4M550

1950 Edition

Printed in U.S.A.

Practical Electronic Control Equipment

OPPORTUNITIES IN A NEW FIELD

JUST as electrical power has largely replaced human muscles, so is the "electric eye" gradually replacing the human eye in industry, the "electric feeler" replacing the human sense of touch, the "electric taster" replacing the human sense of taste, and the "electric nose" replacing the human nose. Since electronic tubes play an important part in making these electrical senses carry out desired control operations, we call the entire field *electronic control*.

Electronic control is a new and fast-growing field, and pioneering will be in order for many years yet. Because of your thorough training in radio, you are now in a position to take a leading part in the development of this field and in the application of the already-available electronic devices to industrial needs. There will be only a few precedents to guide you in individual electronic applications (most of these being given in this book), but with an understanding of the standard circuits and setups, you can become an electronic control specialist—if you want to.

Opportunities for the application of practical electronic control equipment exist in almost every industry. If you are now working for an organization which has a need for improved machine controls, you can make your knowledge of electronic control serve as a key to promotions and salary boosts.

Like the field of public address systems, electronic control can be at first simply a side-line for an active, progressive Radio-Trician; eventually it may become even more important than your servicing business. In order to gain the attention of those who need electronic control equipment, make your store or shop "the showroom of modern industrial magic"; install electronic devices which will arouse the interest of your regular customers, who in turn will tell their friends, giving you free advertising. Study the needs of store owners and others in your neighborhood, sell them electronic controls and gradually your ability will attract the attention of factory owners and industrial agents in your town. Remember, though, that while merchants may want only trick devices to attract customers, industry accepts new devices only when they can profitably perform a definite, desired task accurately and dependably.

As the electronic control industry expands, manufacturers of electronic equipment and the agencies which specialize in selling, installing and maintaining the equipment will need more men; those trained in both radio and electronics, as you are, will get first chance at these jobs and will command the highest salaries.

ADVANTAGES OF ELECTRONIC CONTROLS

A few of the more common advantages and reasons for installing electronic control equipment are listed below, to give you some idea of the great variety of projects covered by this new field.

1. Reduction in the cost of producing a product.
2. Reduction in equipment maintenance costs.
3. Insuring more uniform quality of manufactured products.
4. Safeguarding and protecting life and property.
5. Speeding up industrial operations.
6. Counting objects accurately.
7. Inspecting and adjusting manufactured products with greater accuracy and speed than is possible even with the best workers.
8. Acting as a constant attendant in supervising actions which occur at irregular intervals or when least expected.
9. Attracting and holding the attention of prospective customers.
10. Controlling things which cannot be detected by the human senses.
11. Controlling objects too fragile for mechanical controls.
12. Improving the efficiency of human workers.

ANALYZING THE JOB

No matter what application of electronic control equipment you may be considering, first study and analyze the job. Be absolutely fair; will a simple mechanical or electrical control work as efficiently and be less expensive? If it will, suggest it even though this may mean less profit to you. If a simple push-button set into a door frame will set off an alarm when the door is opened, it is unwise to recommend a light beam and photocell control device for this purpose. If an overflow of liquid can be detected by a floating ball on a hinged arm, it is folly to recommend a photoelectric control here. The customer will eventually discover the least expensive way, and if you have erred, intentionally or not, you will lose prestige. Be fair and you will go far in this field.

If the request for a control originates with some one else, be sure to get a clear statement of what is to be accomplished; if the control is to be a part of an existing machine or process, study the machine or process. You must not upset the existing conditions. If the job originates with you, then you should already have all necessary data. Place your ideas and plans on paper, work out the design, study the results, and when you are convinced that your project will prove valuable, prepare a written report, giving: 1, the purpose of the control; 2, the advantages; 3, the design; 4, the estimated cost; 5, savings to be gained by its use; 6, estimated time required to make the installation. This report constitutes your bid for the job; always secure the written approval of the customer on the entire job and on your price, and secure an advance payment when you think it necessary. When the job is finished and in operation, call back periodically to inspect its operation. Purchase commercially available equipment made by reliable concerns, making full use of their engineering consultation service; construct only those parts which are not standard or readily obtained.

BASIC PARTS OF A CONTROL SYSTEM

In every electronic control system you will find some or all of the following important parts:

1. *The detector*, which converts the physical change being controlled into a desired electrical change, either directly or by means of mechanically actuated contacts. With photoelectric controls the electric eye is the detector; with temperature controls, a thermostat, mercury column thermometer, or some other device which responds to changes in temperature serves as detector; with humidity controls a special indicator using one or more pieces of blonde human hair may be the detector.
2. *The introductory system*, which brings before the detector the object or agent to be analyzed. For example, the introductory system may be a conveyer belt which makes the packages being counted pass in front of the electric eye; it may be the railing on each side of the approach to a door, which compels a person to walk through the light beam; it may be a special pipe or wire which makes the liquids, gases or the electric current being supervised pass in front of or through the detecting device. We must include in the introductory system all of the devices which insure proper operation of the detector; for example, with the electric eye the entire optical arrangement is a part of the introductory system.
3. *Amplifying and power relay devices* are often essential components of an electronic control system. In one sense the amplifier is the "automatic brain" of the system, building up the weak current changes produced by the detector to give sufficient energy for a positive control, and at the same time selecting and handling in an orderly, prescribed manner the controlling impulses. Vacuum and gas amplifier tubes, relays of all kinds, circuits with unique characteristics, and electromechanical "gear switching" systems play vital parts in the final control operation.
4. *The device being controlled* is naturally the most important part of an electronic control system, for it must perform the desired action. The operation of this device is of far more importance to its owner than the means of controlling the device. If the device is to open and close a door automatically, we must consider the electric motor, the worm and drive gears, the reversing switch, the limit-of-travel switches and the door itself.

PHOTOELECTRIC CONTROL SYSTEMS

Photoelectric control holds an important position in the field of electronic control; commercial apparatus for all standard photoelectric jobs has been on the market for many years, and is available at reasonable prices in a wide range of models. Existing equipment is easily modified by electronic engineers to meet special requirements of individual applications, when necessary. For these reasons we will pay special attention to the photoelectric branch of electronic control.

In analyzing the average light-sensitive control circuit, you will find the following basic units: 1, the light-sensitive cell; 2, the light source with its associated optical system; 3, the amplifier and sensitive relay (or super-sensitive relay with sensitive relay); 4, the power relay; 5, the device being controlled. Before going into specific photoelectric applications, a general discussion of these essential units will be helpful.

The Light-Sensitive Cell. This is the detector in a photoelectric system, changing its electrical characteristics in response to changes in the quantity and quality (color) of light. The three basic types of cells are the *photoemissive*, *photoconductive*, and *photovoltaic cells*. When the light

beam is to be invisible to the human eye, infra-red light is generally utilized; photoconductive (selenium) cells and photoemissive cells are generally used with "invisible" beams, for they have high infra-red response.

Light Source and Optical System. A source of artificial light and an optical system for directing the greatest possible amount of this light on the light-sensitive cell are necessary in all photoelectric control systems except those which are designed especially to respond to general illumination.

The 6-8 volt, 32 candlepower automobile headlight bulb has become more or less standardized as a photoelectric light source, but in some units a 110 volt home movie projector type of lamp is used in order to permit operation of the bulb on either 110 volts A.C. or D.C. With the low voltage lamp a step-down transformer is needed, the secondary having several taps. The lamp should always be operated at the lowest voltage which gives sufficient illumination, to secure long lamp life. Twin filament lamps are generally used; when one filament burns out, the position of the lamp in its bayonet type socket is merely reversed. These lamps have a high infra-red output and can, therefore, be used with an infra-red filter to produce an invisible beam.

Either parabolic mirrors or convex spherical lenses can be used to concentrate light from the source into a narrow beam. Lenses are more widely used than reflectors for this purpose, since lenses are lower in cost, simpler to adjust, and permit focusing of the beam to any desired position.

Photoelectric light sources must be rugged in construction, for they are often subjected to considerable abuse. In some cases, as in door-opening installations, persons or trucks may bump the unit or its support; inquisitive persons will seek to discover what is inside that "cute little box," and in outdoor installations snow, rain, ice and sleet will batter the unit. Representative commercial light sources are shown in Figs. 1A, 1B, 1C and 1D; in each, a step-down transformer is built into the lamp housing, and a spherical lens is placed in front of the lamp. The position of either the lamp socket or the lens is adjustable; the lamp is set at the focal point of the lens when an approximately parallel beam is wanted, and back of the focal point (but at less than twice the focal distance) when the converging beam is to be focused on the light-sensitive cell. In general, the beam of light is adjusted to have a greater diameter (at the light-sensitive cell) than the cell cathode; this prevents vibration in any part of the optical system from throwing the beam off the cell and causing improper operation of the control system.

The average photoelectric control unit requires an illumination of about 5-foot candles on the light-sensitive cell; the maximum distances at which this intensity can be obtained for the light sources shown in Figs. 1B and 1D, and for two sizes of ordinary incandescent lights without lenses or reflectors are given on the graph in Fig. 2. With ordinary 110-volt lamps the illumination varies inversely as the square of the distance, and therefore drops off rapidly as the light-sensitive cell is moved away from the lamp. Ordinary lamps are unsuited for producing powerful beams, principally because their filaments have too large an area.

The photograph in Fig. 3 illustrates a practical photoelectric application, where a beam of light directed across the punch press prevents the press from operating until the operator's hands are out of danger. The light-sensitive cell, placed in the dust-proof metal housing at the right, has a tubular visor to keep out all light except that reaching it from the light source at the left. When the distances involved are as short as this, no

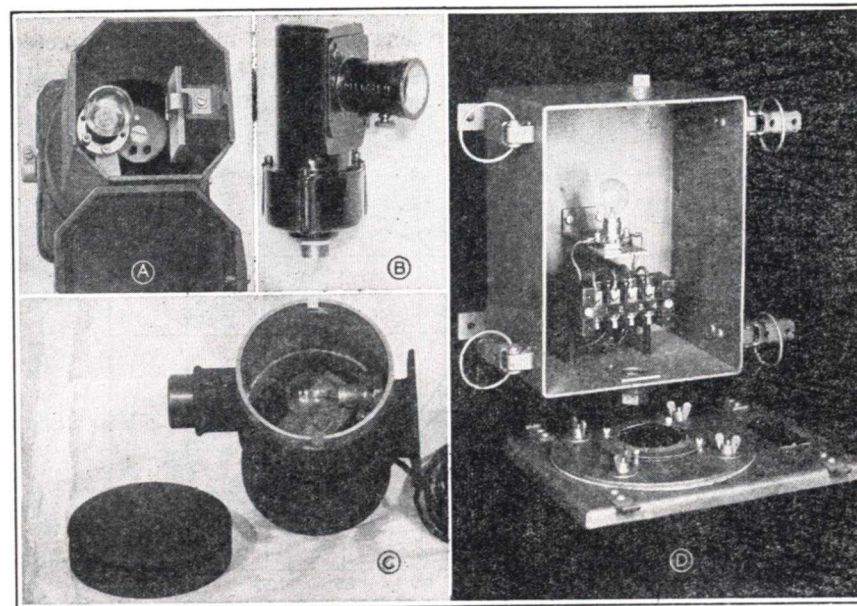

FIG. 1A. This light source, a *Western Electric* product, has a light filter (two panes of colored glass) held in place between the lamp and the lens barrel by a spring clip. Careful design of the castings used for the housing gives a sturdy, weather-proof unit.

FIG. 1B. *Westinghouse* type F general purpose light source, designed for indoor use. The transformer is housed in the lower casting; the adjusting screw on the lens barrel is loosened while focusing, then tightened to hold the lens in the desired position. Provisions are made for attaching metal conduit at the base, through which the wires to the transformer can be run.

FIG. 1C. Another simple light source with transformer, in a weather-proof cast iron housing. Adjusting screw clamps lens tube in desired position.

FIG. 1D. View of interior of *Westinghouse* type B long range light source, designed for either indoor or outdoor use. Light-concentrating lens is rigidly mounted in cover, but lamp socket can be moved backward or forward for focusing. Unit is designed to deliver a parallel beam which is about 5 inches in diameter at a point 10 feet away from lens. Note that in each of these four light sources, a step-down transformer is mounted below the lamp, and no reflectors are used.

light-collecting lens is needed, and even the light-concentrating lens on the source can often be dispensed with if a simple reflector is used back of the lamp. When protecting the operators of machines against their own carelessness in this way, electromagnetic devices are usually attached to the operating lever of the machine to prevent release of the lever when the operator's hands are in the danger zone; a careful study of each installation is necessary, for the machine must not be slowed up unless the operator actually is in danger.

A photoelectric control unit utilizing a light-collecting lens is shown in Fig. 4; this lens concentrates a large-diameter beam on the photocell cathode. Light-collecting lenses like this are generally required where the

light beam is transmitted for distances greater than 15 to 40 feet (depending upon the type of light source used).

Mirrors can be placed in the path of a light beam to change its direction, but each reflection from an ordinary mirror results in a loss of about 40% of the light reaching the mirror. This loss can be compensated for by using a stronger light source and better optical system. The mirror used must be large enough to reflect all of the light beam.

Some light is also lost (through reflection) when a beam is directed through a plate glass window or a pane of glass; the loss is about 5% for zero angle of incidence (at right angles to the glass), and increases to 25% for a 45 degree angle of incidence.

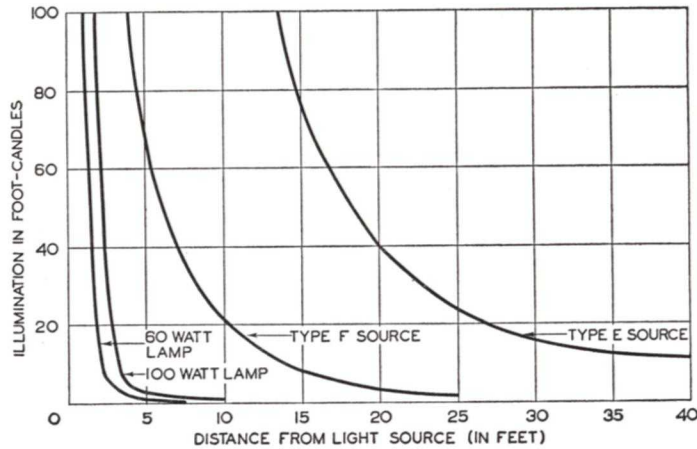

FIG. 2. This graph gives maximum intensities of illumination at different distances from the type F Westinghouse light source (pictured at B in Fig. 1), from the type E Westinghouse unit (pictured at D in Fig. 1) and from two sizes of ordinary incandescent lamps.

The light-sensitive cell may either be housed in the amplifier and relay box, as shown in Fig. 4, or may be placed in a special housing similar to the housing used for light sources. A separately mounted photocell is pictured in Fig. 5, connections being made between cell and amplifier by wires running through a grounded BX cable; since the photocell is essentially a high impedance device, these precautions must be taken to reduce undesirable pickup in the connecting leads. Manufacturers supply special cable for making connections to photocells like this.

Visors of the forms shown in Figs. 4 and 5 are essential where a beam of light is directed on a photocell, for these visors exclude light from other sources and thus prevent improper operation of the equipment.

Amplifier and Relay Unit. This is the "brain" of the control system, interpreting what the light-sensitive cell sees; it can be made to act on impulses of light, on gradual changes, or on differences in the color of light; it can be made to ignore anything but slow permanent changes; it can be made selective in its action. All the peculiarities of radio and electrical circuits can be put to use to get actions which appear nothing short of magical to the general public.

It is customary to place the amplifier stages and sensitive relays in a single housing; the photocell is often placed in this housing too, as it is in Fig. 4. The power pack, the special circuits and the circuit-adjusting controls are housed in the same box, giving a compact, easily serviced unit. Heavy-duty relays are usually placed in a separate housing mounted close to the device being controlled. Bear in mind that when photovoltaic cells are used, only relays are needed; the cell feeds directly into a super-sensitive relay which may control motor-operated switches or relays.

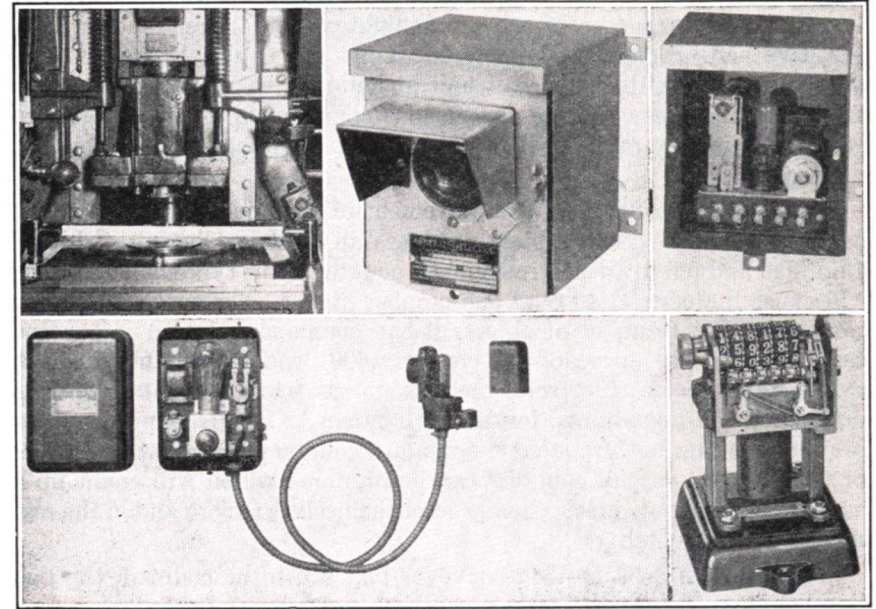

FIG. 3 (upper left). A beam of light may here save a worker's hand some day. The powerful punch press cannot operate while the beam of light is interrupted, for the photoelectric amplifier and relays are interlocked with the press controls.

FIG. 4 (upper center and right). Two views of General Electric CR7505-M1 outdoor photoelectric relay with self-contained photocell and light-collecting lens. Light intensities as low as 3 foot-candles will cause relay to pull up; light beam should be completely intercepted for relay

to drop out. Note metal visor over lens to keep out slanting rays of sun.

FIG. 5 (lower left). General Electric CR7505-A5 indoor type photoelectric relay with covers removed. Photocell is in separate housing, connected to relay unit by BX armored cable.

FIG. 6 (lower right). Typical electromagnet counter (made by Production Instrument Co.) with cover removed to show the six number wheels. The maximum operating speed is here 25,000 counts per hour.

The Device Being Controlled. Photoelectric equipment is essentially designed to control electrical apparatus, the largest relay in the system being connected to start and stop the electrical device which is to be controlled. Where the desired operation is of a mechanical nature, additional devices are sometimes needed; for example, when the flow of gas or water to a device is to be controlled, the final relay would be connected to an electromagnetic valve. In some cases, as in automatic door openers, motors are used to give the required mechanical motion.

Basic Considerations. In applying photoelectric controls to industrial or commercial jobs, the manner in which the optical system will react

should be given full consideration. In fact, the types of light-sensitive controls can be grouped according to whether: 1, the light beam is cut off or on; 2, the light beam merely varies in intensity; 3, the color content of the light beam varies. A better understanding of photoelectric control systems will be obtained if typical systems are studied according to these classifications.

CONTROLS WHERE LIGHT IS CUT OFF OR ON

The commonest type of photoelectric control is that which involves interruption or turning on of a beam of light which is directed on a light-sensitive cell. Standard photoelectric units are available from various manufacturers; with the correct unit at hand, there remains only the installation and connection of the various components to give the desired results. A few examples will be taken up to show how simple this is in most cases.

Counters (Slow Speed). The movement of an object through the light beam of a photoelectric system produces an electrical impulse which, if amplified and fed to an electromagnetic counter of the type shown in Fig. 6, will cause the counter to read one number higher. The speed of the control equipment (number of objects it can count per minute) is governed essentially by the speed of the counter; 600 "counts" per minute is an average top speed. Electromagnetic counters require about 5 watts of power and can be obtained for use with either A.C. or D.C. power of any practical voltage and frequency. Standard counters will count up to 9,999 or 999,999, but special counters can be obtained which will count up to any desired amount, automatically reset themselves to zero and in the reset process trip a switch.

When objects on a moving conveyer belt are to be counted, the light beam is directed across the belt; each object interrupts the beam once, and the photoelectric amplifier sends one impulse to the counter. The conveyer here places the objects in the proper position for counting, and no other introductory devices are needed. On the other hand, when persons are being counted, it is necessary to design the introductory system so that only one person can pass through the beam at a time. This is done by constructing a passageway or entrance just wide enough for a single person.

Another interesting photoelectric counter application is that where definite quantities of some small object are to be placed in containers. The reset type of counter can be used here, the final switch action being used to control a conveyer which will bring an empty container into position ready for a new count.

One-Way Counter. When objects pass through the beam in both directions, as in the case of automobiles going over a highway or bridge, a special counting circuit can be used to count only the cars moving in one direction. This circuit, given in Fig. 7, uses either selenium cells or photo-cells. With the cells connected as shown, illumination on a cell lowers the cell resistance, makes the amplifier tube grid more negative and thus

lowers the plate current; interruption of a light beam therefore increases the plate current of the associated amplifier tube.

With a circuit like that shown in Fig. 7, only objects moving upward will be counted. When light is on both cells, the plate currents of the two tubes are a minimum and all three relays are in their drop-out positions as shown; an object moving upward first interrupts the beam on P_B , causing relay R_B to pull up. The contacts of R_A and R_B are both closed now, but R_C cannot pull up for the simple reason that plate current in VT_A is still a minimum and is insufficient to operate both R_A and R_C , now in parallel with each other. The object moves farther up, to a position where it interrupts both beams; the plate current of VT_A increases, but—and here is the secret of this circuit—the coil of R_C has so much lower a resistance than the coil of R_A that only R_C pulls up. In other words, relay R_A cannot get sufficient current for its operation when R_C is in parallel with it. The pulling up of R_C closes the contacts which control the electromagnetic counter, and one count is registered. As the object moves on, the beam of

FIG. 7. One form of selective circuit for a one-way photoelectric counter. Objects moving upward over the shaded path are counted; those moving down do not give a count. In some installations the electromagnetic counter can be connected in place of R_C , eliminating one relay, provided that the operating coil of the counter has the same electrical characteristics as the coil of R_C .

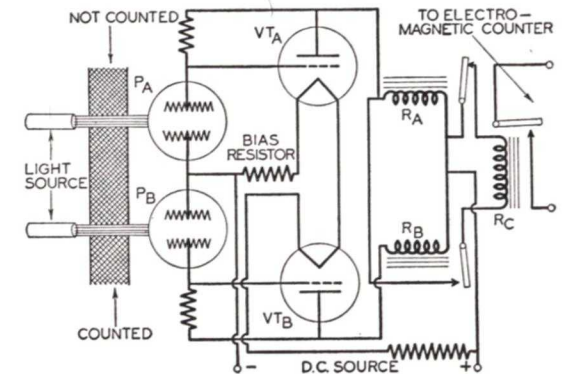

P_B is restored first, causing R_B and R_C to drop out; with R_C no longer "stealing" current from R_A , the latter relay pulls up, but nothing else can happen. When the object leaves the last beam, restoring light to P_A , R_A drops out, closing its contacts, and the system is ready for another count.

Now let us see why no count is made for an object moving in a downward direction. The beam of P_A is interrupted first, and R_A pulls up. Nothing else happens until the object moves into the lower beam, cutting off light to P_B ; relay R_B now closes, but since the contacts of R_A are open, R_C is not energized and there is no count. When light is restored to P_A , the contacts of R_A close; R_C cannot pull up now because VT_A has minimum current and the electromagnetic counter does not operate. Finally, when light is restored to P_B , the contacts of R_B open, and the system is restored to its original condition.

Objects shorter than the separation between the two beams are not counted, since both beams must be interrupted at some instant, and in the proper order. Special counting systems like this are usually built to order

by electronic equipment manufacturers, since they are required only for specialized applications.

High-Speed Counters. In industries where small products such as cigarettes, nuts, bolts, etc., are produced at speeds far in excess of the counting ability of an ordinary electromagnetic counter, special circuits have been developed which will "memorize" impulses and operate the counter once for a definite number of impulses.

One type of high speed counting arrangement, shown in Fig. 8, uses one small size gas triode for each impulse which is to be "memorized"; the multiplying factor for the registered count is therefore four when four tubes are used. The grids of all tubes are fed simultaneously by impulses from the light-sensitive cell amplifier, through coupling condensers C , but the cathode bias resistances and connections are such that only one tube is "fired" (passes current) at any time, and this "firing" primes the following tube so it can be "fired" by the next impulse. The plates of the tubes are connected to a D.C. source; you will remember that once a gas triode in a D.C. circuit fires, the grid loses control and plate current can be stopped only by interrupting the plate current or removing the plate voltage.

Let us trace through the operation of the circuit from the time it is turned on. The D.C. voltages applied to the plates and the grid bias batteries are of such values that no tube can fire when voltage is first applied, even when signal impulses come through. The circuit must therefore be initially primed (one tube made to fire) by throwing switch SW momentarily to position 1, placing zero bias on tube VT_A and causing it to fire; the switch is then thrown to position 2 permanently, applying the bias voltage of battery B_D to tube VT_A . With tube VT_A passing current, the voltage drop in the lower part of potentiometer R_A opposes the bias voltage of battery B_A (applied to the grid to VT_B) and the net bias on VT_B is made less negative. The first signal impulse to come from the photocell circuit will fire tube VT_B now, but will not affect tubes VT_C and VT_D , which are still biased highly negative, or tube VT_A , which is passing current. The firing of tube VT_B causes condenser C_A to act momentarily as a short circuit, drawing a large current through R_A . The voltage drop across R_A momentarily becomes so great that the voltage between plate and cathode of VT_A is insufficient to maintain ionization. Current flow in VT_A stops, and its grid regains control.

The first signal impulse has thus fired tube VT_B , extinguished VT_A and "primed" the grid circuit of VT_C ; the next impulse will fire VT_C , extinguish VT_B and prime VT_D ; the third impulse will fire VT_D , making the electromagnetic counter read one digit higher, and will extinguish VT_C and prime VT_A , completing the cycle. Since the first impulse was created artificially by manipulating SW , the total number of actual impulses will be (in this circuit) one less than four times the counter reading (provided VT_D is firing when the reading is taken).

Photoelectric Alarms. It has often been suggested that photoelectric controls be used as burglar alarms or for announcing the arrival of a person or car, the interruption of either a visible or invisible light beam causing the alarm to sound; in the majority of such cases, however, it is cheaper

and more practical to use simple mechanical switches for the purpose. These switches might be simple make-and-break affairs mounted on all doors and windows which must be opened to enter a room or, in the case of filling stations, might be metal plate switches in the driveway or a pneumatic switch which operates when a car drives over a rubber hose. Capacity controls utilizing feedback-controlled oscillators, to be described shortly, should be considered.

Where open passageways or definite areas in a room are to be guarded, and where mechanical systems are impractical, undesirable or too costly, photoelectric controls can be used to advantage. Standard photoelectric amplifier units can be used, with an ordinary power relay if the alarm is to operate only when the beam is interrupted, or with a latch-in type relay if the alarm is to operate until the relay is reset manually.

Many unique photoelectric alarm systems have been devised. In one case the interruption of the light beam opened and closed the shutter of a camera and set off a photoflash bulb, taking a picture of the intruder; an

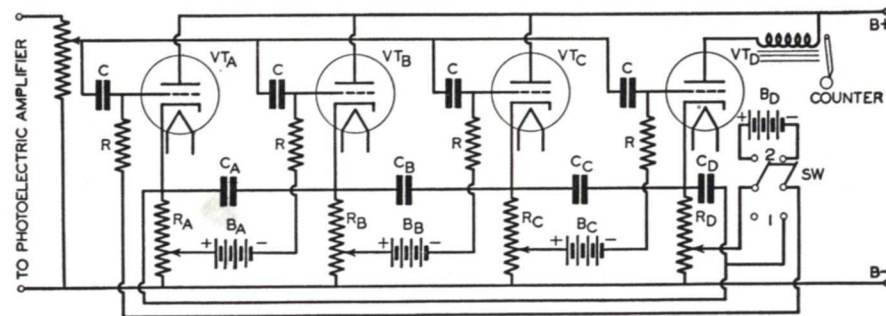

FIG. 8. High speed photoelectric counter circuit, which "memorizes" impulses fed to it by a photocell and amplifier, and operates the electromagnetic counter once for every four impulses.

alarm gong was also set into operation, scaring off the intruder before he could locate and wreck the camera.

Effortless Action Switches. Where an action is desired with no effort on the part of the operator and no mechanical pressure on the product or object being controlled, the photoelectric control fills an important need. Standard photoelectric control equipment can generally be used, the introductory system being designed to meet the requirements of each particular application.

An automatic sanitary drinking fountain is a good example of an effortless action switch. It is a simple matter to arrange the light source and light-sensitive cell so that a person bending over the fountain interrupts the light beam. The regular fountain valve is replaced by an electromagnetic valve which is controlled by the contacts of the power relay in the photocell amplifier circuit. The light beam can be made invisible when a mystery effect is desired.

The general appearance of an electromagnetic water valve is shown in Fig. 9; the mechanism is usually quite simple, consisting of a soft steel plunger with a conical bronze point which is normally held against the

orifice (water outlet) by a spring. When the solenoid or coil surrounding the plunger is energized, the plunger is pulled away, allowing water to flow through the valve.

Effortless controls find many uses in manufacturing plants. Where strips of cloth, cellophane and similar materials which are subject to shrinkage have woven patterns or printed designs whose positions are critical, shrinkage causes errors in cutting and considerable waste when automatic cutting machinery is used. Errors due to shrinkage accumulate rapidly, especially in high-speed machinery, with the result that the machine must be stopped and reset at frequent intervals. Photoelectric control of the position of the printed pattern with relation to the cutting knife completely eliminates these troubles. A dot or other mark woven or printed in the margin of the sheet at each point where a cut is to be made is all that the electric eye needs to do its work. Light source and electric eye are mounted close to each other in a manner similar to that shown in Fig. 10, so that the

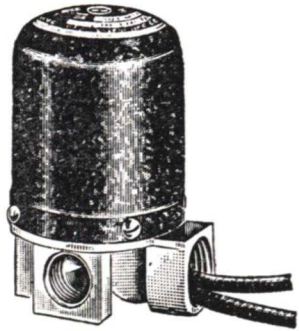

FIG. 9. A typical electromagnetic water valve.

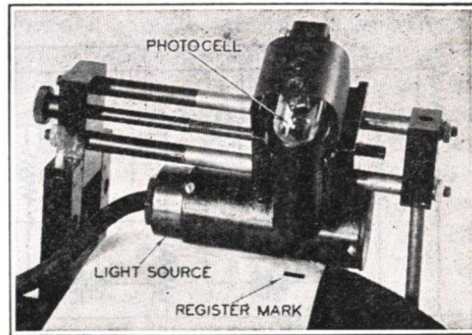

FIG. 10. The "detecting" section of a photoelectric registry control.

light-sensitive cell can detect the changes in light reflected from the moving sheet of material.

Photoelectric register controls like this are now being used extensively in connection with package wrapping machinery like that shown in Fig. 11; here a friction brake is used to correct the speed of the moving paper at the command of the photoelectric control system, to insure correct register.

Automatic Door Openers. The opening of doors automatically as a person or vehicle approaches is becoming a very popular job for photoelectric controls. Doors in garages, stores, hospitals, restaurants, factories and public buildings are today controlled by interruption of beams of light.

Door opening mechanisms are available for the opening and closing of three general types of doors: 1, doors which open inwardly or outwardly, or swing in both directions; 2, sliding doors; 3, overhead doors. The door opening mechanisms can be divided into two general groups: 1, those using electric motors operating worm gear drives, cables running over pulleys, or a link motion mechanism; 2, pneumatically operated openers, in which the motion of one or more pistons under the action of compressed air is transferred into motion of the door by link mechanisms.

Each door opening installation requires a complete photoelectric control at the approach, to cause the door to open when some one enters the introductory system, and generally another complete photoelectric control to close the door after the person or vehicle has passed through and interrupted a light beam on the other side. In many installations, of course, it is more feasible to arrange a manual control for closing the door; in private garages this especially holds true, for here the door must remain open as long as the engine of the car is running, to prevent an accumulation of deadly carbon monoxide gas. In this particular case the driver must get out of his car anyway, so it is no hardship for him to turn a switch on the wall to close the doors.

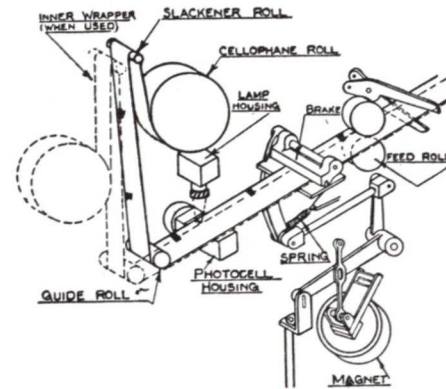

Courtesy Package Machinery Co.

FIG. 11A (above). Simplified sketch of photoelectric registry control mechanism.

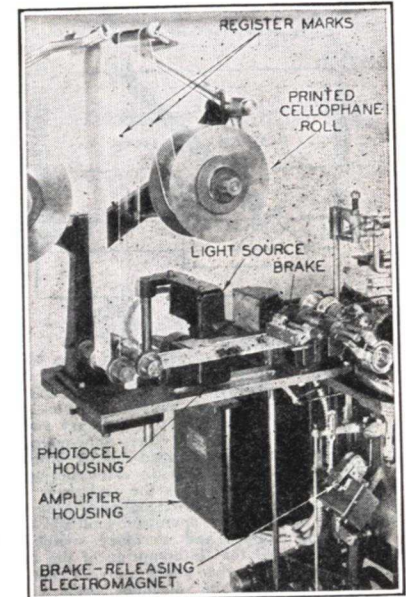

FIG. 11B (right). View of modern packing machine; cellophane rolls containing printed designs are accurately cut to required size sheets by means of photoelectric registry control, insuring that the pattern is perfectly centered on each sheet.

When very long objects, such as a truck and trailer or a long string of trailers, may pass through a door, the truck may intercept the closing light beam before the last car has cleared the door; in cases like this it is necessary to use an additional light beam or some other means of indicating to the "brain" of the photoelectric system that the doorway is being blocked. One solution to this problem, a light beam directed diagonally through the doorway, is shown in Fig. 12.

In Fig. 13 is shown a typical photoelectric door opening installation; a photoelectric cell and light source are mounted inside the railings placed on either side of the entrance, while the pneumatic door opening mechanism is mounted above the door. A motor driven air compressor and storage tank, located in a remote place, provide air pressure at the correct value. Interrupting one beam opens the doors and interrupting the beam on the other side of the door closes the doors.

The advantage of a pneumatic door opener lies in its ability to open and close doors almost instantly, with a minimum of noise. Where slower acting doors are permissible, as in garages and in industrial plants, motor driven mechanisms can be employed; typical examples of these are shown in Figs. 14A, 14B, 14C and 14D. A reversible motor is generally used; note that in Fig. 14A the cable actuates a link mechanism; in Fig. 14B an endless cable running over two pulleys moves the sliding doors in and out; in Fig. 14C a gear box operates levers connected to the two swinging doors; in Fig. 14D an endless cable pulls the door up overhead. Worm and screw mechanisms driven by electric motors are also widely used for these types of doors. The possibility of power failure must always be considered in a door opening

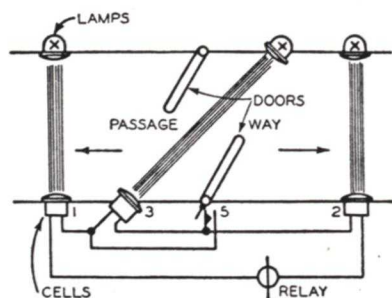

FIG. 12 (above). Arrangement of light beams for fool-proof photoelectric door-opening system. Three photovoltaic cells connected in series feed into one super-sensitive relay whose contacts in turn control a rotary switch, power relays and finally the door-operating mechanism. Cell 3 is shorted out by switch 5 when the doors are closed. Interruption of either cross-beam increases the resistance of a cell about five times, lowering circuit current enough to cause relay operation and make the doors open. Relays and a rotary switch are so interconnected that interruption of the other cross-beam closes the doors only if nothing is blocking the diagonal beam.

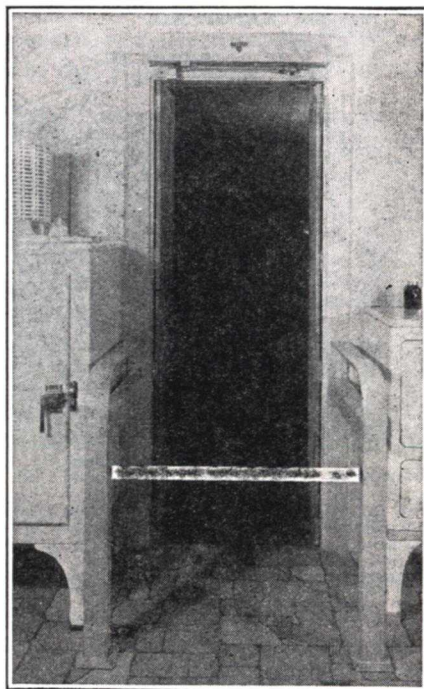

FIG. 13 (right). Installation of Stanley automatic door opener in kitchen of modern home.

mechanism; it should be possible to open and close the doors manually when power is off. Detailed information on door opening mechanisms can best be obtained from the literature supplied by the various manufacturers.

Automatic Inspection. Photoelectric controls can be applied to practically any automatic inspection application, but as a rule considerable ingenuity is required to design and install the system. A description of a typical application will give some idea of the problems involved. In the automobile manufacturing industry it is necessary to test a large number of steel parts for hardness. The instrument ordinarily used for testing hardness contains a diamond pointed weight which is dropped on the object from a fixed height, the hardness of the object being determined by the

height of rebound of the weight. The higher the rebound, the harder is the material. The weight (often called the hammer) moves inside a vertical glass tube alongside which is a scale indicating the height; the hammer is drawn to the top of the tube by suction, then allowed to drop. Objects which do not give a rebound to a certain definite height are rejected. To make the hardness inspection automatic, a light beam is focused so its cross-over point is inside the glass tube; if this beam is intercepted by the hammer on the rebound, the object is considered okay and is moved along by the conveyer system; if the hammer does not reach the light beam, a rejecting mechanism kicks the object into a basket for further treatment

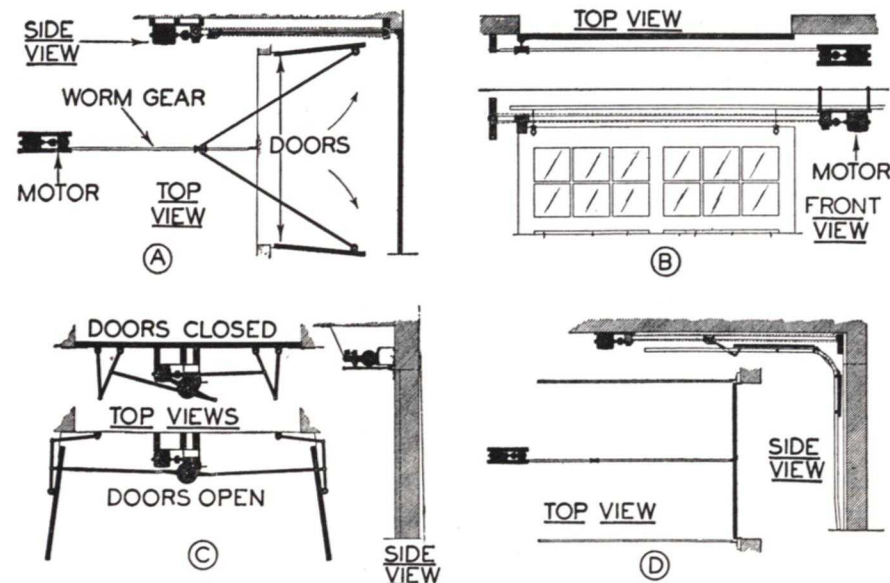

FIG. 14. Types of electric door-operating mechanisms. A—top and side views of motor-driven worm gear mechanism for opening outward-swinging double doors; B—motor-driven endless cable for opening single-section sliding door; C—motor-driven crank and link mechanism for opening inward-swinging double doors; D—motor-driven endless cable type opener for overhead doors.

or scrapping. A second light beam directed through the glass tube below the first beam is so connected to the amplifiers and relays that the descending hammer resets the latch-in relays in readiness for another monitoring operation as the hammer ascends. Naturally the rejecting mechanism must be carefully designed to give the desired results and make the entire testing procedure automatic.

CONTROLS FOR VARIABLE LIGHT INTENSITIES

Variations in the *amount* of light reaching the light-sensitive cell (rather than complete cut-off of the light beam) cause relay operation in a number of photoelectric control systems. Controls like these are possible because relays can be made to pull up or drop out at definite values of coil current corresponding to definite values of illumination on the cell; general illumi-

nation in a room or outdoors, which is gradually changed by movement of clouds or the sun, can be utilized to actuate the photoelectric control system. The passage of dust, smoke or fog through a light beam, the change in opacity of a liquid through which the light beam is directed, or the partial blocking of a light beam by a moving object are a few other examples of variable illumination. Some practical applications where variable light intensity is used will now be taken up.

Spark Plug Gap Adjustments. As automotive spark plugs are now manufactured and assembled, it is necessary to adjust the gap between the points to the correct value by a separate operation after assembly. Previously an accurate thickness gauge was held in the gap and a vibrating hammer used to bend the outer electrode against this gauge; unless the operator was very careful in stopping the hammer, a few extra blows would be delivered, cracking the porcelain insulator. At least one spark plug manufacturing plant has now replaced the steel thickness gauge with a light beam gauge, so arranged that when the outer electrode blocks off the light by an amount corresponding to the correct gap, the photoelectric control system automatically stops the vibrating hammer. Naturally a very small diameter but high intensity light beam is needed; this is obtained by focusing light to a cone having a minimum diameter at the gap. All light passing through the gap is collected by a light-sensitive cell, which is connected to an amplifier in such a way that a definite decrease in light intensity actuates the relay.

Smoke Detectors. Many towns and cities now have laws limiting the amount of smoke which factories, apartment buildings and other large users of coal and other fuels can release from chimneys and smoke stacks. Aside from the fact that smoke is a nuisance to the public, its presence indicates incomplete combustion and wastage of fuel, the amount of smoke being a direct indication of the inefficiency of combustion. If a beam of light is directed through the chimney or smoke stack to a photoelectric cell, as shown in Fig. 15A, increases in smoke will reduce the light reaching the photoelectric cell. If this cell is connected to an amplifier, the plate current of the amplifier tube will change in value according to the amount of smoke. A relay can be inserted in the circuit and adjusted to close its contacts and sound an alarm when the amount of smoke exceeds a certain definite value. A meter can be inserted in the plate circuit of the amplifier stage to indicate the relative amount of smoke present at all times, or a recording instrument can be connected to the amplifier to give a continuous record of the amount of smoke passing up the chimney. Various combinations of relays can be used for special indicating purposes; in one system, shown in Fig. 15B, a red light is made to flash on to indicate improper combustion, and a green light is illuminated when combustion efficiency is satisfactory. Relays can also be connected to correct the excessive smoke condition automatically; this is usually done by having the relay start a blower which feeds more air to the furnace and improves fuel combustion.

In most cases, the light beam intensity and the amplifier circuit must be adjusted, after the equipment is first installed, by making an analysis of

the gases going up the chimney, and computing the percentage of efficiency of combustion for various amplifier settings. Special measuring instruments are available for this purpose. In general, combustion efficiency is at a maximum when a haze appears at the top of the chimney. Since the correct installation of a photoelectric smoke detector requires considerable knowledge of steam engineering, these systems are generally installed by firms which specialize in this one field. While some manufacturers of smoke detectors prefer to carry out the entire installation themselves, others will cooperate with you and your customer in working out a satisfactory system for a particular location.

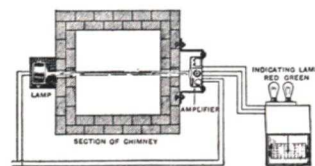
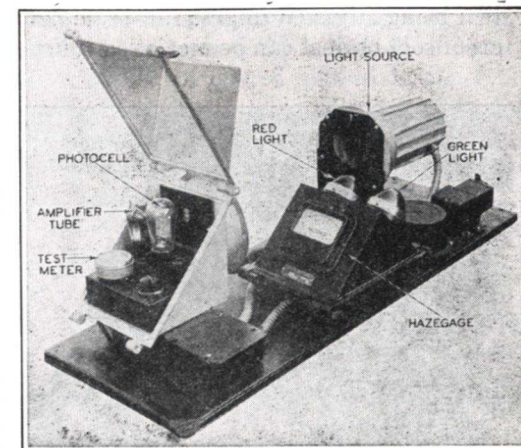

FIG. 15A (above). Simplified diagram of a representative photoelectric combustion efficiency recorder and smoke alarm.

Courtesy Ess Instrument Co.

FIG. 15B (right). All parts of the Ess Model HGL-4 Combustion Indicator system appear here, mounted on a "breadboard" for display purposes. Hazegage with signal lights is ordinarily mounted in boiler room.



In some photoelectric smoke detectors, the panes of glass which protect the light source and the photoelectric cell are kept clean continually by a motor driven wiping mechanism, while in others some provision is made for adjusting the voltage of the light source to compensate for dust and smoke on the glass. In the latter case it is generally necessary to clean the glass windows about once a week.

Turbidity and Opacity Measuring Devices. The turbidity of a solution (the amount of foreign material in the liquid) is easily estimated by measuring the reduction in the intensity of a beam of light which is directed through a sample of the solution, the emerging light beam being directed on a light-sensitive cell which is connected to a suitable amplifier and indicating meter. Where a continuous indication or record of the turbidity of a solution is required, as in chemical processes, or where pure water is required for drinking purposes or for manufacturing processes, it is customary to by-pass a small portion of the main water supply, allowing this water to run through a short length of glass tubing through which the light beam can be directed. One light beam is directed through this glass tube which carries water to be analyzed, and another light beam is directed through a similar tube carrying pure distilled water. The two light-sensitive cells are connected to a special linear amplifier circuit known as a differential circuit, which responds to the difference in the outputs of the two cells and

causes an indicating meter to register the amount of turbidity in the solution being analyzed. Recording instruments and alarm devices may also be connected to the amplifier if desired. Colored liquids or dyes can be continually monitored in this way; sometimes color filters are used in the optical system to make the photocell respond to changes in the most important color present in the liquid under test.

Opacity, the ability of a material to block light, and transparency, the ability of a material to transmit light, can both be measured in a manner similar to that used for checking turbidity. The material to be inspected is either placed in the light beam or drawn slowly through it; the associated amplifier is connected to a meter which reads from zero to 100 per cent, the system being adjusted to give full-scale percentage transparency directly. Films of soot or dust can be measured if deposited on a clear pane of glass;

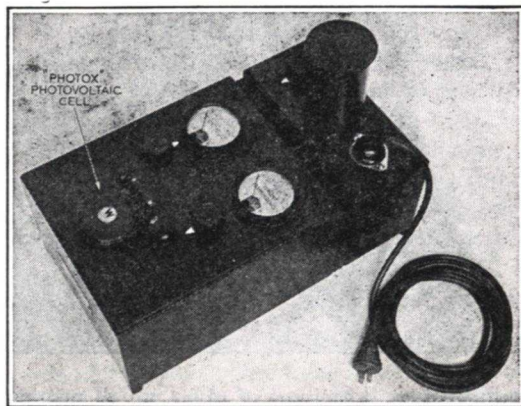

FIG. 16. Westinghouse Trans-O-Meter, a simple portable device for measuring the percentage of transparency of paper, films, fabrics or any other thin flat material. Housing of photovoltaic cell raises so material can be slipped under it.

the meter is adjusted to read 100 per cent with only the glass in the light beam, to counteract losses of light in the glass itself.

A representative transparency measuring instrument is shown in Fig. 16; this can also be used to measure opacity and turbidity by following the directions supplied with the instrument. The photovoltaic cell used here is corrected with filters to have the same color response as the human eye.

Photoelectric egg candling systems operate on much the same principle as the transparency measuring instrument. The eggs are first sorted by operators for size and color of the shell, and are then placed on a conveyer system which carries them through the egg candling machine. A rejecting mechanism controlled by an electromagnetic lever pushes eggs of inferior quality off the conveyer belt.

Illumination Controls. The importance of adequate illumination in securing maximum efficiency of workers is rapidly becoming recognized. Today we want light when it is needed, and not necessarily when it is time for the sun to set or when some one suddenly notices "it is getting pretty dark." If sunlight returns after artificial lights have been on for a while, the effects of the sun so greatly overshadow the effects of the artificial sources that no one realizes lights are on and power is wasted. Ad-

vertising signs, highway lights, window display lights and school room lighting systems are just a few examples where automatic control of illumination is today being used to great advantage. It is generally recognized that for working purposes, between fifteen and thirty foot-candles of illumination are ordinarily required; for street illumination between .5 and 2 foot-candles are sufficient, while about 6 foot-candles are needed for proper illumination of advertising signs. It is the light-sensitive cell with its discriminating control apparatus which makes automatic control of illumination at different levels possible. Various types of commercial illumination controls are now on the market, these being adjustable to turn lights on at a certain minimum level of illumination, and to turn the lights off again when illumination exceeds a prescribed maximum value.

Illumination controls are, as a rule, quite easy to install. The control box containing the light-sensitive cell is, of course, placed in the room whose illumination is to be controlled, it being so located that the cell sees the average light coming from the area being monitored. The contacts of the illumination control relay are connected into the circuit containing the lights being controlled.

There are many different types of illumination control circuits, each manufacturer generally showing a preference for a particular circuit. That shown in Fig. 17 is a good example, however, and will therefore be studied in detail. In this circuit, P is a photocell connected between cathode and grid of vacuum tube VT , while potentiometers R_2 and R_3 control the negative grid bias of VT . Although the plate of this tube receives A.C. power, the circuit is in operation only for that half of each cycle when the plate is positive (when transformer polarity is as indicated). Since the photocell anode and the plate are positive at the same time, the photocell passes current and acts like a variable resistance during the active half-cycle.

The operation of this circuit is as follows: When the photocell is dark (insufficient illumination), the resistance of the cell is high and the grid bias (determined by the ratio of the resistances $R_1 + R$ to the cell resistance) is highly negative. Plate current of VT is therefore a minimum, and relay A is in the drop-out position, as shown. Contacts a are closed; relay B is getting power directly from the A.C. line, and is therefore in the pull-up position shown. Contacts S , controlling the load, are closed, and artificial lights are on. Note that under these conditions R_3 is out of the circuit; R_2 therefore determines the level, as natural illumination increases, at which plate current is sufficient to actuate relay A .

When natural illumination increases to the level at which the customer decides artificial lights are no longer needed, the increasing illumination on P has lowered its resistance, making the grid of VT less negative (closer to the cathode in potential), and thus increasing the plate current of VT to a value which causes relay A to pull up. Armature K now moves to contact b and relay B now receives its current through time delay button (or time delay relay) M , whose contacts were closed. Current passing through the heater resistance in M causes its contacts to open in a definite time interval. With relay armature K pulled up and the contacts at M open, relay B drops out; contacts S open, turning off the artificial lights;

contacts 2 open, and time delay button *N* is now in series with the coil of relay *B*; contacts 1 close, connecting potentiometer R_3 in the circuit. The moving arms of R_3 and R_2 are thus connected together through resistor R , which has a sufficiently high ohmic value to prevent overloading of the transformer, and the grid bias will be determined solely by the setting of R_3 .

The lights are now off; when natural illumination drops below the level determined by the position of R_3 , the resistance of the photocell increases, plate current of *VT* decreases to the drop-out value for relay *A*, and armature *K* drops out to make contact with *a*. Remember that relay *B* is still in the drop-out position; the coil of *B* now gets its power through the heater resistor of time delay button *N* (whose contacts are open when cold), but this heater resistance keeps the current through *B* below its pull-up value. In a definite time interval the contacts of *N* close, allowing relay *B* to pull up. Now contacts 3 turn on the lights; contacts 2 close, shorting out *N* and allowing it to cool in readiness for the next cycle of operation, contacts 1 open, cutting out R_3 and allowing R_2 to take control again.

This system provides separate adjustments for low and high values of illumination, eliminating any need for adjusting the relays to certain pull-up and drop-out values. The two time delay buttons act to prevent flashing of lights on and off where changes in illumination are temporary, such as changes caused by passing clouds in the daytime, flashes of lightning at night, or persons walking directly in front of the light-sensitive cell.

Sorting According to Size. Objects having a definite geometrical shape but different sizes can be accurately sorted according to size if passed through a beam of light which is a part of a photoelectric control system. In some cases the light is beamed through a tunnel whose cross-section corresponds to the shape of the largest object being inspected, the inside of the tunnel being painted black to prevent reflections of light. The objects being inspected are carried through this light-tunnel by a conveyer system, and the amount of light passing around the object is condensed onto a photoelectric cell by a collecting lens. The smaller the object, the more light will reach the photocell; the amplifier and a rejecting circuit can be adjusted to reject all objects under a certain size. One form of rejecting mechanism, which can be used to "kick" objects off a moving belt, is shown in Fig. 18.

When more than two sizes of objects are to be sorted, one photoelectric analyzer is usually required for each size. The objects are passed through each analyzing position in turn, a separation into two sizes being made at each position. Even tape, ribbon or wire can be monitored for size in this way; the material is made to pass through the analyzing beam, and when its width exceeds certain dimensions, an alarm or signal system either warns the operator or stops the machine. Thousands of other photoelectric sorting and inspection applications are possible, but in general, standard photoelectric amplifier circuits can be used. Your job is to choose the correct relays and the optical system.

CONTROLS WHERE COLOR OF LIGHT VARIES

Photoelectric cells, as you know, have varying responses to light of different colors, each type of cell having its own peculiar color response characteristic. It is therefore possible to use photoelectric controls in sorting objects like beans, eggs, sliced pineapple, cigars and sheets of paper as to shades of whiteness or color; similar photoelectric controls can be used to supervise the roasting of coffee, the baking of cake and bread, the pre-heating of steel before treatment for tempering, and the control of any other products whose final quality is determined by the color of light which it reflects or emits.

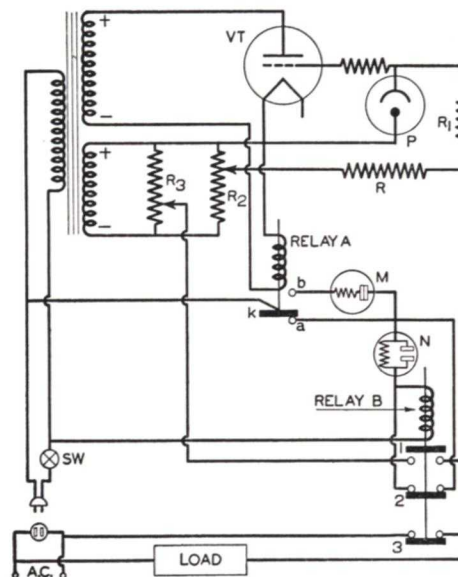

Fig. 17 (left). Photoelectric illumination control circuit.

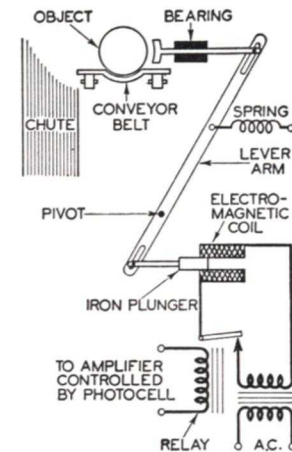

Fig. 18 (above). One type of mechanism which kicks objects off a conveyer belt in response to impulses from a light-sensitive cell. A special mechanism must be developed for each installation.

Sorting Closely-Related Colors. Sorting of light and dark objects is comparatively simple, for here the difference in the amount of light reflected from the object is quite appreciable; ordinary photoelectric control units are generally quite satisfactory for sorting objects which differ greatly in color. When there are only slight variations in the color of a certain product, and the variations in the amount of white light reflected are not sufficient for accurate photoelectric sorting, an expert sorter first separates a large number of samples of the product into the desired number of groups according to shades of color; in other words, this expert sets an example which the photoelectric color sorter must follow. The products in each group are now put through a special color-analyzing process which determines the average percentages of the primary colors, red, blue and green, in that group. The controlling color for all groups (that color which varies greatest in amount in all objects sorted) is then determined, and a filter is selected which will allow only the one particular color to pass.

Since one photoelectric color sorter can ordinarily separate objects into only two groups (corresponding to relay pull-up and relay drop-out positions), an extra sorter is needed for each extra group (above two) into which a product is to be sorted; a filter of the selected color is inserted in each of the light beams, so that the different shades of color produce the greatest possible differences in light-sensitive cell response. Each sorting unit is then adjusted to "pick out" objects belonging in one of the groups originally set up by the expert sorter.

Only a single photoelectric color analyzing system is needed when controlling a process where the color of the object changes gradually, such as in the roasting of coffee. When the electric eye "sees" the correct color, it causes relays to cut off the heat and sound an alarm.

Color Analyzing. In many manufacturing processes where the color of a product is important, the sensitivity of the human eye to shades of a color is not sufficiently accurate for production purposes. Photoelectric color analyzers have been designed to replace the human eye for this purpose; although many different types of analyzers are on the market, the basic principles of these can be secured by studying the simplified diagram shown in Fig. 19. Here a photovoltaic cell whose color response has been corrected with filters to approximate that of the human eye is arranged to "see" light which is reflected from the object being analyzed by a lamp which is filtered to make it approximate sunlight. The meter connected across the photovoltaic cell gives a minimum deflection when a pure white surface is being analyzed, and for other colors gives readings which are proportional to the amount of light reflected. By inserting red, blue and green filters in the path of the light beam in turn, the amounts of each primary color reflected from the product can be determined.

Photoelectric Installation Questionnaire. To be certain that you are ordering the proper equipment for a particular photoelectric job, it is wise to check over the following list of questions, making sure that each factor has been properly considered:

LIGHT BEAM

1. Can visible light be used, or must the light be practically invisible?
2. Will the light beam be horizontal or at an angle?
3. How many mirrors, if any, are required for the beam?
4. What is the total length of the light beam?
5. What is the size of the intercepting object?
6. How far will the intercepting object be from the light source?

LIGHT-SENSITIVE CELL

1. Will the cell be in the relay housing?
2. If the cell is mounted separately, how far is it from the relay?
3. Will direct or reflected sunlight or strong artificial light enter the cell housing?
4. What is the temperature range at the location of the installation?
5. Is the equipment subject to excessive dampness?
6. Will any housings be subject to direct heat of the sun?
7. If equipment is used outdoors, in what direction will light be sent from source to cell?

RELAYS

1. What is the maximum number of relay operations per minute?
2. What is the voltage, current and frequency of the circuit to be controlled?
3. What is the nature of the load? (Is it highly inductive?)
4. Will relay be in pull-up or drop-out position when light is on cell?
5. What is minimum duration of complete light change which is to actuate relay?

INSTALLATION

1. Are there any limits on size of housings?
2. Are cell and light source housings readily accessible for cleaning?
3. Are units to be mounted on floor, walls or ceilings?
4. What are maximum and minimum values of line voltage?
5. What is the power line frequency?
6. If unit is to be used at night, what is the night voltage range?
7. Is one side of the power line solidly grounded?
8. How many hours a day, days a week and weeks a year is unit to be in use?

OTHER TYPES OF DETECTORS

It has already been pointed out that many of the other human senses besides that of sight can be replaced by man-made devices which produce a change in electrical or mechanical characteristics, corresponding to a change in the effect being supervised. These detectors can be used with all of the circuits just described, where they replace only the light-sensitive cell. Each type of detector will be considered in turn, and a few of the practical applications taken up in each case.

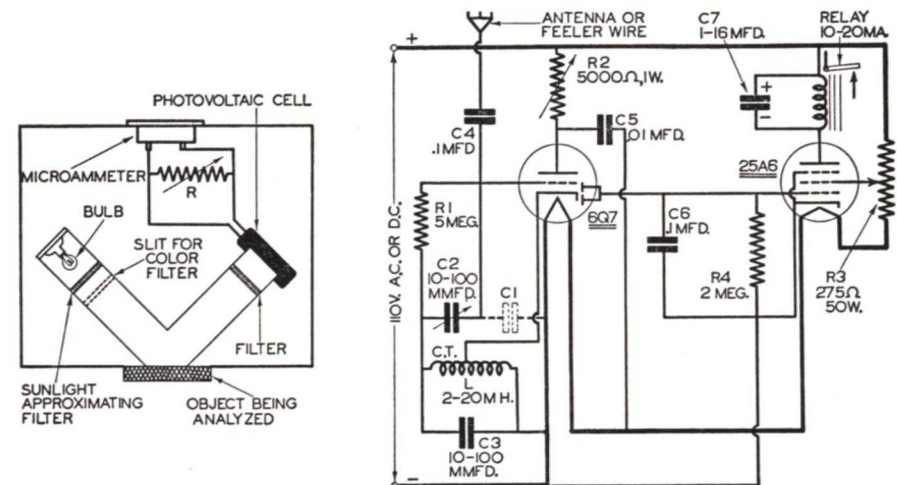

FIG. 19. Simplified sketch of one form of photoelectric color analyzer. Photovoltaic cell has filter which gives it color response of human eye. *R* adjusts meter sensitivity.

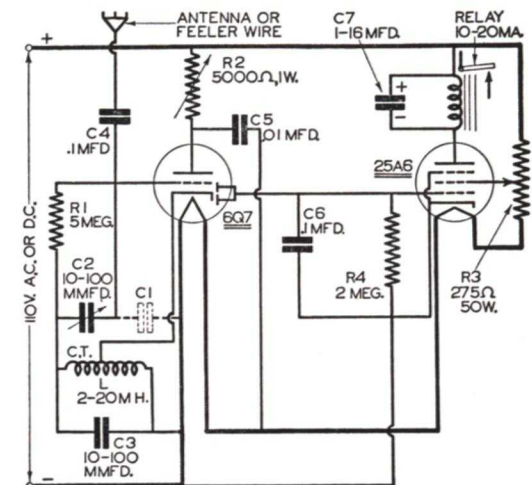

FIG. 20. Schematic circuit diagram of capacity control circuit. Condenser *C7* is needed only for A.C. operation, to prevent relay chatter; the indicated polarity must be observed if an electrolytic condenser is used. Any external capacity between antenna wire and ground has the same effect as would a condenser at *C1*.

Feeler (Capacity) Controls. It is often desirable to have an alarm system which will operate when a person or object approaches within a definite distance of the object or area being protected. Photoelectric alarm systems are impractical for protecting areas of irregular size, since the light beam can travel only in a straight path, and reflection by mirrors introduces heavy losses in light. The solution to the problem lies in a feeler or capacity control, which consists essentially of a feed-back oscillator in which the degree of oscillation is controlled by the feed-back capacity introduced by the feeler or antenna circuit. The feeler may be a single wire stretched around the area being protected, at a height of about three feet above ground; it may be a metal plate located underneath a display table containing valuable jewelry or other articles, or it may be a metal object such as a safe.

A simple and practical feeler control circuit, designed by F. H. Shepard, Jr., of R. C. A. Mfg. Co., is shown in Fig. 20; the triode section of a 6Q7 duo-diode triode tube forms an oscillating circuit with coil *L* and condenser *C3*, the feed-back voltage of which is controlled by variable condenser *C2* and the capacity existing between the feeler wire and ground (represented by *C1* in Fig. 20). The antenna is simply an insulated wire

acting alone or connected to the metal object being guarded. Condenser *C4* is inserted in series with the antenna lead to prevent a direct connection to the power supply, since no transformer is used. The diode sections of the 6Q7 tube, connected in parallel, rectify the oscillator current; the resulting D.C. output, which is proportional to the strength of the oscillations, is fed to the grid of the 25A6 amplifier tube. Potentiometer *R3* varies the screen voltage applied to the amplifier tube.

The circuit is initially adjusted to give maximum oscillator output when nothing is near the antenna. The output of the diodes is therefore a *maximum*, the bias on the amplifier tube is *highly negative*, plate current through the relay is *low* and the relay armature is in its *drop-out* position. When a person or vehicle approaches the antenna, increasing the antenna-to-ground capacitance (*C1*), the intensity of oscillation is reduced and the diodes feed a less negative bias to the amplifier; the amplifier plate current goes up, operating the relay. When first adjusting the circuit, potentiometer *R3* is adjusted until the relay just drops out when nothing is near the antenna; the next step is to adjust condenser *C2*, with a person in the position at which operation of the control is desired, until the relay pulls up.

Temperature Controls. Millions of temperature control devices of various types are in use today, opening and closing contacts in response to changes in temperature. Some of these devices actuate the contacts either directly or through mechanical levers, while others require amplifiers followed by relays. Let us study a few typical detectors.

The bi-metallic strip type of temperature control, in which two dissimilar strips of metal (welded together) curl and uncurl, causing a lever arm to move from one contact to another in response to changes in temperature, is pictured in Fig. 21A. This detector is extensively used in room heating control systems and in other applications where a large movement but only a relatively small force is required.

Another temperature detector, one which depends upon the expansion and contraction of a liquid with changes in temperature, is shown in Fig. 21B; here considerable force is exerted by the expanding liquid. The liquid is placed in a specially constructed metal bellows which readily changes its shape as the liquid changes in volume. One side of the bellows is fixed, while the other presses against a lever arm which is held down by a small spring. Contacts mounted on this arm may move between fixed contacts, or the arm can be made to tilt a mercury type switch.

The change in the resistance of a wire with temperature is the operating principle of the temperature detector shown in Fig. 21C. The resistor here forms one arm of a Wheatstone bridge, the circuit being balanced for a definite temperature. Deviations from this temperature produce an unbalanced circuit; the resultant voltage and current are used as a means of controlling the heat-producing device or for operating an alarm or indicating system.

The thermocouple shown in Fig. 21D must be connected either to a super-sensitive relay or to an amplifier circuit. The temperature range of the thermocouple can be changed by adjusting the pull-up current value of the relay or by changing the bias on the grid of the amplifier tube.

When the temperature being controlled varies between definite known limits, mercury column thermometers having wire contacts imbedded in the glass walls can be used as temperature controls; the arrangement is shown in Fig. 21E. The rise and fall of the column of mercury makes and breaks the circuit between the two contact wires.

When the temperature being controlled is subject to change from time to time, the photoelectric scheme shown in Fig. 21F is sometimes used. Here the rising column of mercury intercepts the coned beam of light at its cross-over point.

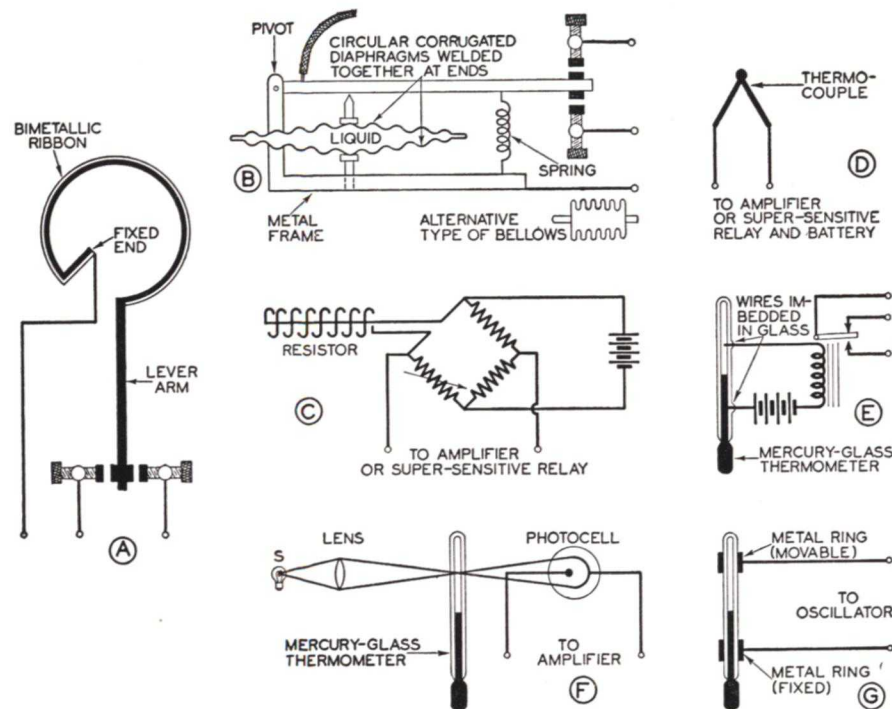

FIG. 21. Seven different methods of converting changes in temperature into electrical changes.

An alternative adjustable thermometer method is pictured in Fig. 21G. The column of mercury varies the capacity between two metal rings slipped over the thermometer, this change in capacity changing the intensity of oscillation of a capacity control like that shown in Fig. 20, and thus causing a relay to pull up.

Humidity Controls. All practical humidity controls operate upon the principle that a porous detecting material, such as paper or human hair, will stretch more when damp than when dry. A humidity control depending upon the expansion of paper when damp is shown in Fig. 22A; a thin layer of the paper is cemented carefully to a very thin coiled strip of hard brass. The paper keeps the coil spring under tension (wound up) when dry, but when humidity rises the paper becomes damp and offers

less resistance to the uncoiling of the spring, thus closing the contacts. Naturally, in a system like this, high contact pressures are difficult to obtain; this scheme is used extensively, however, in direct indicating humidity meters.

A more reliable humidity control, which in one case is used to tilt a heavy-duty mercury switch, is pictured in Fig. 22B. Human hairs arranged in bundles are here kept under tension by a spring; as the hairs become damp with rising humidity, the spring stretches the hairs to a greater length, moving the lever arm and tilting the mercury switch. By adjusting the position of the switch pivot, the control can be set for any desired humidity value within its range, and by changing the position of the pivot on the lever arm the sensitivity of the control can be adjusted.

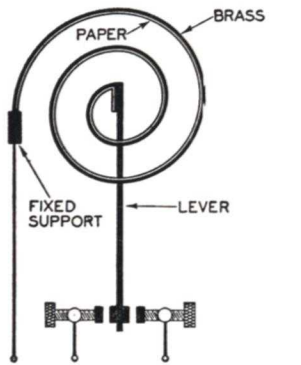

FIG. 22A. Humidity detector using special moisture-absorbing paper cemented to spring brass strip.

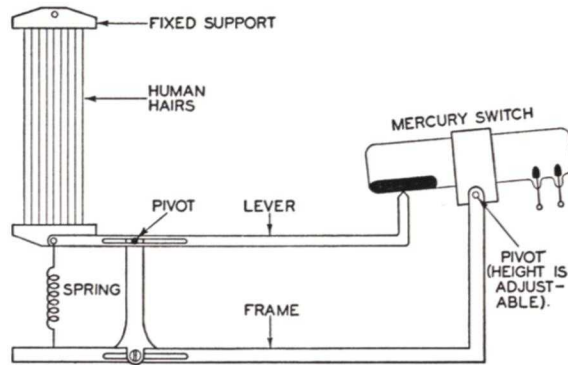

FIG. 22B. Humidity detector for heavy duty operation, using stretched human hairs whose lengths vary with the amount of moisture in the air.

Sound Controls. An ordinary radio microphone serves as a detector in a system where a sound is to start or stop a certain device or machine. The output of the microphone must be amplified and then passed to a vacuum tube stage whose output is practically independent of the frequency of the sound, but is dependent upon the signal intensity.

A self-rectifying A.C.-D.C. audio amplifier circuit for a sound control system is given in Fig. 23; the type 38 output tube is here highly negatively biased by variable resistor R_6 . The relay is of the latch-in type, so any sound whose duration is greater than the pull-up speed of the relay will operate the relay and give the desired control. This sound control system can be used, for example, to make garage doors open when an automobile horn is blown. A directional microphone is in this case placed above the doors, and directed outward toward the driveway. Potentiometer R_5 is adjusted to give relay operation with the lowest horn noise which will be encountered. With this adjustment completed, extraneous noise from the street or shouting will have no effect upon the system.

Taste Testers. At present it may be stretching the imagination a little too far to say that a simple detecting device can tell you whether one chocolate bar has more of the chocolate taste than another bar, but it is

perfectly possible to tell whether one food product is more sour than another. For example, we can tell whether one lemon, apple, grapefruit, pineapple, or even a glass of vinegar is more sour than another, since all these products contain acids. A taste detecting device consists simply of two probes, one of copper and the other of zinc, which are inserted in the product to be tasted. In an acid fruit or solution these two probes generate an e.m.f., and a microammeter connected across the probes indicates a current flow which is proportional to the acid concentration. By fixing the separation of the probes and the depth of immersion, citrus fruits can be accurately compared as to taste. The sensitivity of the taster can be increased by using a D.C. amplifier.

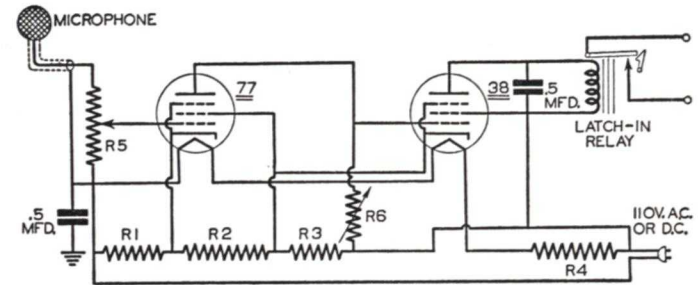

FIG. 23. Two stage audio frequency amplifier for sound control circuit. Circuit constants are: R_1 —75 ohms, 2 watts; R_2 —500 ohms, 5 watts; R_3 —500 ohms, 5 watts; R_4 —325 ohms Cordohm; R_5 —.5 megohm potentiometer; R_6 —.5 megohm variable resistor.

The water content of any product can be checked in much the same manner, if the microammeter is replaced with a megohm meter (an ohmmeter capable of measuring resistance up to about 50 megohms, sometimes called a *megger*). The moisture content of wood is readily checked in this way by driving steel needle into the wood a short distance apart and measuring the resistance between the needles.

Automatic control of the taste of a product can be secured simply by connecting suitable amplifiers and relays to the taste detecting device.

Gas Detectors. It is a well-known fact that gases like carbon monoxide, illuminating gas and hydrogen can cause wires or discs made of platinum black (spongy platinum) to become very hot. This is due to an action called adsorption or surface combustion of gas. Flameless cigarette and gas stove lighters operate on this principle. Naturally the resistance of the material increases with its temperature; this change in resistance can be utilized in a Wheatstone bridge circuit to give any desired control or to operate an alarm when gas is present. A thermocouple placed in contact with the spongy platinum to measure its temperature can also be used as a means of detecting gas.

A wire made with a platinum-iridium alloy exhibits slight surface combustion effects in the presence of various gases (becomes warm), but is not sufficiently sensitive by itself for gas detection purposes. If the wire is primed, however, by sending a steady heating current through it, combustion of the gas increases and temperature changes in the wire become suffi-

ciently great for detection. Platinum is the essential element here; iridium is included only to harden the platinum and make it more resistant to the high temperatures involved.

Unfortunately, spongy platinum makes no distinction between various kinds of gas; this gas detector is therefore limited in its use to conditions where only one kind of gas exists. If hydrogen is a component of the gas in question and the detector is to be operated cold (without a priming current), a mixture of palladium and platinum gives considerably greater sensitivity to gas. Practical applications include searching for leaks in gas pipes and monitoring the amount of hydrogen escaping from alkaline (Edison) storage batteries. Where a selective device is required, such as for detecting the presence of deadly carbon monoxide gas in airplanes, automobiles and garages, a chemical converter type of detector must be used. The chemist sets up a system which causes the carbon monoxide gas to change from one form to another, this action producing a change in heat which can be detected by a thermocouple.

Radio Off-On Controls. Many different schemes have been devised for operating small devices or even airplanes and battleships by radio from distant points. The principle of remote controlled radio operation is quite simple; a low-power, high frequency (about 50 megacycles) oscillator is used at the control station, and a simple tuned input detector receiver whose output feeds a relay is located at the receiving end of the system. The starting of the oscillator causes the plate current in the receiver to rise or fall, depending upon how connections are made, thus actuating the relay which starts or stops the device being controlled. In more complicated systems the oscillator sends out different code signals, and a selective relay connected into the output of the receiver responds to these various codes and performs the desired switching operation. If the codes are kept secret, only the correct transmitter can actuate the selective relay.

Conclusion. Although no attempt has been made in this book to analyze all possible forms of detectors, sufficient information to stimulate your imagination has been given. Radio and mechanical experience, together with an inventive mind, are the requirements for developing electronic controls to replace man's natural senses of seeing, hearing, feeling, tasting and talking.



SINCERITY

We are often told that a man must rely on himself for success. In one way this is true—but it is not true that a man can become successful in any line of work without the cooperation of others. Were it not for the fact that we are all living together in associations of various kinds, there would be no point in striving for success, or in being successful.

For this reason, men who desire to become successful can not ignore other people; they can not ride rough-shod over the feelings of others; they must be considerate, courteous, fair, honorable.

Possibly we can sum up all this in two words—be sincere. If you are really sincere, you will be honest, fair, kind and considerate.

All truly successful men are sincere. Success built on insincerity is not success; it can not last, nor is it complete and satisfying. Only merited success is complete and satisfying. Be sincere—if you want the kind of success that brings happiness.

J. E. Smith