

**TV RECEIVER POWER SUPPLIES,
SOUND CHANNELS, AND A.G.C.**

Finish

57RH-3

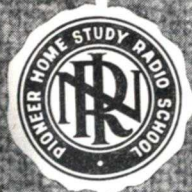

NATIONAL RADIO INSTITUTE

WASHINGTON, D. C.

ESTABLISHED 1914

STUDY SCHEDULE NO. 57

For each study step, read the assigned pages first at your usual speed, then reread slowly one or more times. Finish with one quick reading to fix the important facts firmly in your mind. Study each other step in this same way.

- 1. **Introduction**Pages 1-11
The four major kinds of high-voltage power supplies, basic high-voltage distribution systems, and methods of producing extra-high voltages are described in this section.
- 2. **Low-Voltage Power Supplies**Pages 11-18
Here you study the power supplies that are used to furnish plate and filament power in TV sets.
- 3. **The Sound Channel**Pages 18-27
The characteristics and operation of the sound channel in sets using the standard and the intercarrier sound systems are described in this section.
- 4. **Automatic Gain Control**Pages 28-36
You study the circuits used to produce automatic control of video gain in this section.
- 5. **Answer Lesson Questions, and Mail your Answers to NRI for Grading.**
- 6. **Start Studying the Next Lesson.**

COPYRIGHT 1950 BY NATIONAL TELEVISION INSTITUTE, WASHINGTON, D. C.
(An Affiliate of the National Radio Institute)

BP5M250

Printed in U.S.A.

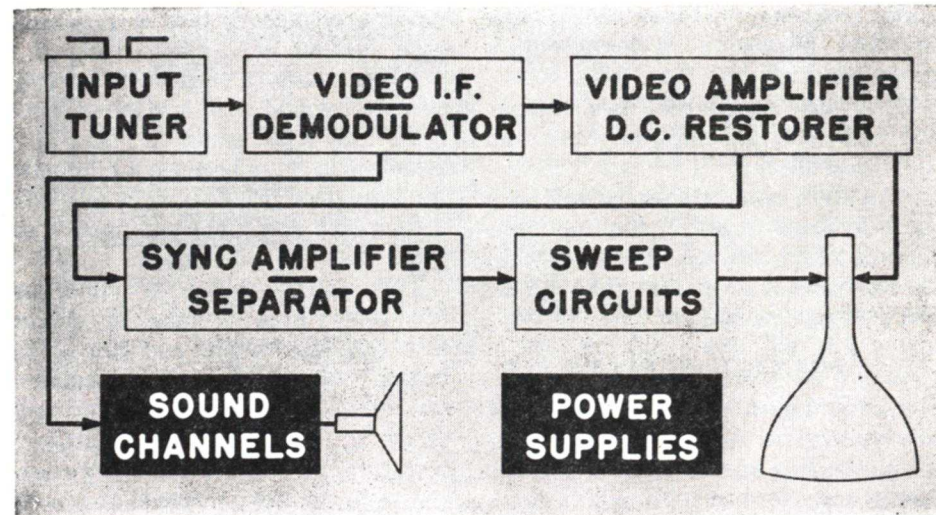

TELEVISION RECEIVERS differ from sound receivers rather markedly in their power supplies. First, a TV receiver always has two supplies: 1, a high-voltage, low-current supply; and 2, a "low-voltage" B supply that is required to furnish voltages in the range from 100 volts to 400 volts at a rather high current level.

The "low-voltage" supply more or less corresponds to the B supply of sound receivers, but because of the large number of stages in the video chain from the antenna to the picture tube, plus the sync and sweep stages, plus the stages in the sound section (which you are going to study in this Lesson), the current and voltage demands made on it are unusually large. Later in this Lesson, we are going to study the B supply in detail.

First, however, let's learn how the high-voltage supply operates.

TYPES OF HIGH-VOLTAGE SUPPLIES

The electrons in the beam in the picture tube must be accelerated by a high voltage if they are to strike the screen with enough velocity to make the fluorescent material glow. The

small direct-view picture tubes (7 inches or smaller) will operate reasonably well with voltages under 5000 volts between the second anode and the cathode, but the larger direct-view tubes all require considerably higher voltages—as much as 15,000 volts for a 16-inch tube. The tube in a projection system is commonly operated at 25,000 to 30,000 volts. A TV set must therefore have a power supply capable of furnishing a voltage somewhere between 3000 and 30,000 volts, depending on its type. This supply must be reliable and as safe as possible.

Since it is impractical to get such a high voltage from the same power supply that is used for all the other tubes in the receiver, a TV set always has a separate high-voltage power supply. There are four types of these power supplies now in use, and we shall describe them in turn. They are:

1. A 60-cycle power supply that uses a conventional power transformer and rectifier-filter system almost identical with the low-voltage types with which you are already familiar.

2. A rectified r.f. power supply that uses an r.f. oscillator operating on

some frequency between 50 kc. and 300 kc., followed by a rectifier-filter arrangement.

3. A pulse supply that uses a blocking oscillator, an amplifier tube, and a rectifier-filter.

4. A kick-back supply (also known as a fly-back supply) that operates from the high voltage kick-back from the horizontal scanning yoke of an electromagnetic system.

60-CYCLE SUPPLY

As you know, it is possible to get any voltage we want from a 110-volt a.c. power line by the use of the proper power transformer. To get a high voltage, all we need is a secondary with a sufficient number of turns to give the proper step-up ratio between the secondary and primary. Of course, the secondary windings must be insulated to withstand the high voltage, making such a transformer costly and bulky.

The number of secondary turns needed depends, as Fig. 1 shows, on whether full-wave or half-wave rectification is used. A full-wave rectifier (Fig. 1A) delivers a voltage equal to half the voltage across the secondary, because only half the secondary is used at a time. The same secondary winding in a half-wave rectifier circuit delivers twice as much voltage, because the voltage across the entire winding is used. Of course, the full-wave output is easier to filter, and a higher current may be drawn from it for a given regulation; but these characteristics are not important in a TV high voltage supply, from which very little current is drawn.

At such high voltages, there must be a maximum spacing between the filament and the plate leads to prevent breakdown. For this reason, the plate lead is brought out through a top cap on the tube.

The filter is a standard condenser-

input type except that a resistor is used instead of a choke coil. It is practical to use a resistor because the current demand is so low that there is little d.c. drop across it; and it is desirable to do so because it eliminates the insulation problem we would have with a coil and greatly increases the safety factor of the supply.

This safety factor is important. Electricity kills because of current flow through certain portions of the human body. The body possesses a fair amount of resistance, so ordinarily a reasonably high voltage is necessary before a lethal current can be made to flow through the body. However, people vary a lot in this respect—people with weak hearts may well be killed by currents that would

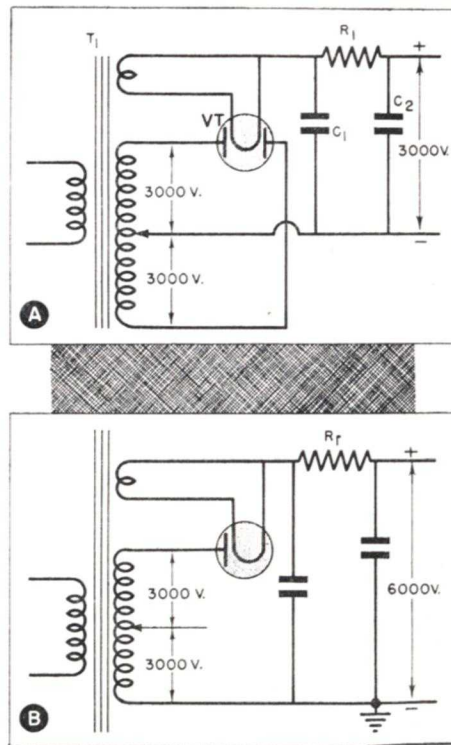

FIG. 1. For the same number of turns on the secondary of the power transformer, a half-wave supply (B) gives twice the output voltage of a full-wave supply (A).

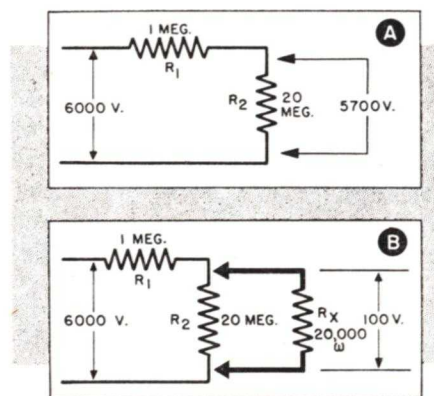

FIG. 2. The use of the series resistor, R_1 , gives the power supply very poor regulation, thus making it safer to work with.

not have much effect on others, and of course the body resistance changes drastically with the state of the health, the dryness of the skin, and other such factors. It is possible to get a severe and even dangerous shock from the voltages present in an ordinary radio set; obviously, the danger from the high voltages of a TV set is even greater.

This danger can be reduced very considerably by using a high resistance instead of a choke coil in the power-supply filter section. If any attempt is made to draw much current from a circuit of this kind, the output voltage will be drastically reduced because of the large drop across the series resistor of the power supply.

This effect is illustrated in Fig. 2. In Fig. 2A is shown a simplified circuit in which a 6000-volt power supply having an internal or filter resistance, R_1 , of 1 megohm is delivering power to a load of 20 megohms. Under these conditions, there will be a voltage of 5700 volts across the load.

Now, suppose a person having a body resistance of about 20,000 ohms happens to get across the load. This will reduce the load resistance to about 20,000 ohms, thus causing a change in

the voltage division in the circuit. As Fig. 2B shows, the load voltage will drop to about 100 volts, and all the rest of the voltage will be dropped across R_1 , the filter resistor.

Therefore, the power supply is made safer if a high-resistance R-C filter is used with it. For extra protection, additional resistors may also be added in series with the plate lead going to the rectifier tube, and the power transformer secondary may be wound with very fine wire so that it will have considerable resistance.

These precautions all help, but they still do not make this kind of power supply completely safe. Even though the current drain on such a supply is very small, it may be necessary to use condensers having capacities of as much as .1 mfd. in the filter circuit to remove all traces of hum ripple. A condenser of this size charged to 5000 or 6000 volts contains enough stored energy to kill. Therefore, NEVER touch a power supply of this type under any circumstances while it is operating. In fact, the supply is not safe even when it is turned off unless the filter condensers have been completely discharged. All sets using power supplies of this kind have safety interlocks so arranged that the power is automatically cut off if the shield around the high-voltage supply is opened. Some even use relays to short-circuit the filter condensers. It is never safe to assume that these safety devices are operating, however. If you work on such a power supply, short the filter condensers individually with a test lead having high-voltage insulation.

Because it is so dangerous, the 60-cycle power supply was used only reluctantly by set manufacturers. Just as soon as the types we are now going to describe proved practical, the 60-cycle power supply fell into disuse.

You are likely to find it now only in some of the older sets that may come in for service.

R.F. POWER SUPPLIES

The amount of current needed from the high-voltage supply for the picture tube is exceedingly small—a matter of a few microamperes. This low drain has made it possible to develop several other methods of obtaining the high voltage.

One of the simplest of these power-supply systems is shown in Fig. 3. The circuit contains a tuned-plate oscillator in which tube VT_1 is used. The tank circuit for this tube is C_4 - L_3 , and the feedback tickler coil is L_1 .

Arranged on the same coil form is a closely coupled winding L_2 . This coil is tuned to resonate with the frequency of the oscillator by its distributed capacity (C_5) and is designed to have a high Q. By resonance step-up, the voltage across this winding can be made to be a number of times higher than that across the oscillator tank (which is practically equal to the B supply voltage of the oscillator).

The high voltage produced across coil L_2 is rectified by VT_2 and is applied to the filter C_6 - R_3 - C_7 . (The output capacity C_7 may be the capacity between the inner and outer coatings on an electromagnetic picture tube. If

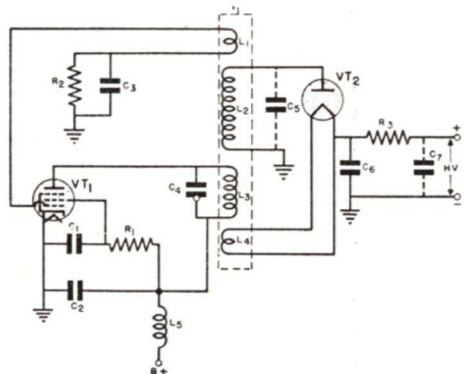

FIG. 3. A simple form of r.f. power supply.

an electrostatic tube is used, it will be an actual condenser.)

Notice that there are a number of important innovations in this circuit. To begin with, this is an r.f. oscillator that operates somewhere in the frequency range between 50 and 300 kc., so r.f. design practices can be followed in its construction. The coil assembly T_1 is a fairly small air-core type rather than a bulky iron-core transformer. Insulation is no great problem, as the spacing between windings gives most of it. Coil L_2 does not need to have a vast number of turns, because the high voltage across it is produced by resonance step-up, not by transformer action.

The oscillator tube is an ordinary receiver-type low-power output tube, because the high-voltage supply requires a power of only about .5 to 1 watt.

The high-voltage output is dependent upon the tuning of the secondary coil L_2 —as a matter of fact, the output voltage is adjusted by varying the tuning condenser in the tank circuit to make its frequency match the resonant frequency of L_2 - C_5 . If this circuit drifts off resonance, the output will drop appreciably. For this reason, this circuit is commonly modified as shown in Fig. 4 so that there is a feedback path from the high-voltage circuit to the oscillator. A coil of wire or a sheet of tinfoil wrapped around the rectifier tube VT_2 is used to couple the oscillator grid to the high-voltage output through the capacity between this coupler and the electron stream in the rectifier. The feedback connections could be made to the end of the high-voltage winding, but using the tube this way is preferable because it gives close coupling and high-voltage insulation at the same time. This coupling makes the high-voltage secondary L_2 become the frequency-controlling winding be-

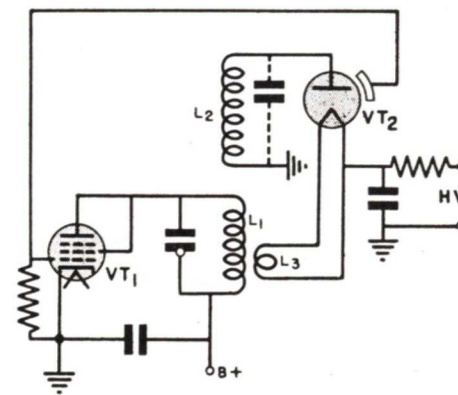

FIG. 4. This method of coupling reduces the possibility of drift in this r.f. power supply.

cause of its high Q, so changing the tuning of the primary has little effect on the output. In other words, the circuits are locked to the resonant frequency of the high-voltage winding, with the result that there is much less danger that frequency drift will reduce the output.

A rectifier tube that has a very low filament-power drain is needed for this circuit. If the rectifier tube filament were supplied from the power transformer as other tubes are, its supply winding would have to have high-voltage insulation, which would make it necessary to use an expensive transformer of special design. Instead, a tube is used that has a filament rating of 1.5 volts and 200 ma. and hence draws only about .3 watt. This low power requirement makes it possible for the tube to get its filament power from the r.f. oscillator as shown in Figs. 3 and 4. The filament winding consists of a one- or two-turn winding on the coil form that is coupled to the primary just tightly enough so that the proper power is removed for lighting the tube filament.

Since there is no way to measure the heating power of the rectifier tube filament directly, you must usually make a visual test to determine

whether the tube is operating properly. Examine a tube while its filament is lighted from a 1.5-volt dry-cell battery to get a good idea of the normal filament brilliancy of the rectifier tube used in this circuit. If the filament is not lighted to its normal brilliancy when the tube is in the power supply, the r.f. oscillator is not producing the right output, and it must be retuned.

Since this is an r.f. power supply, the frequency of the ripple is much higher than that of the ripple in a 60-cycle supply and therefore can be filtered out with much smaller capacities. You will recall that the efficiency of a filter depends on the ratio of the choke (or resistor) impedance to the capacitive reactance. The higher the frequency, the less the reactance of a condenser, so a small condenser can be used to filter out high-frequency ripple; in fact, the filter condensers needed here may be as small as .0005 mfd. Such low-capacity condensers are incapable of storing enough charge to be very dangerous. The use of a high series resistance and low-capacity condensers makes this power supply far safer than the 60-cycle types. Of course, this kind of power supply can still give you a nasty shock, but a person in reasonably good health is not in extreme danger from its output voltage.

An r.f. burn may be experienced if the rectifier tube is approached too closely. Of course, this tube is inside the shield that surrounds the entire power supply, and there should be no danger as long as the supply is not in operation with the shield removed.

The r.f. voltage supply we have just described has two basic faults. One is that it can produce interference. In an ordinary radio, a frequency of 150 kc. or so would be ignored. In a television set, however, this signal will produce a visible interference with the

picture if it gets into the video system. (Remember that the video amplifier is capable of passing frequencies from 10 cycles out to 4 megacycles, so the r.f. oscillator frequency is well within this range.) Careful shielding and filtering of the supply leads are necessary to keep this interference at a minimum.

Another fault is that the high-voltage supply is independent of the sweep circuits. Should the sweep system fail and the high-voltage supply remain on, the electron beam would be concentrated in a single spot on the face of the picture tube. This concentrated beam would burn the fluorescent screen away and thus ruin the tube. (This disadvantage is also possessed by the 60-cycle supply.)

Both these objections are avoided in the two types of power supplies we are now going to describe.

PULSE SUPPLY

The pulse supply shown in Fig. 5 contains a blocking oscillator, an amplifier, and a rectifier. The blocking oscillator produces pulses, just as a similar type does in sweep circuits. These pulses are amplified, then stepped up by transformer T_1 . Since the blocking-oscillator half-wave pulses have a frequency around 150 kc., T_1 is an r.f. transformer.

For reasons that we shall give in a moment, we want this circuit to operate in synchronism with the horizontal sweep. To produce this action, resistors R_2 and R_3 are connected across the B supply. Their resistances are such that the drop across R_2 , which is in the cathode circuit of VT_1 , is a bias sufficient to keep the tube blocked. The oscillator therefore cannot operate until a control pulse is received and is applied across R_2 in such a way that the polarity of the control pulse opposes that of the d.c. drop across this resistor.

This trigger pulse for firing the blocking oscillator is obtained from the output of the horizontal sweep amplifier and occurs only during the retrace portion of the horizontal sweep. Thus, the oscillator VT_1 is unblocked only during the horizontal retrace. As soon as it is unblocked, it generates a pulse. This pulse is completed before the horizontal retrace ends; then the oscillator is blocked again by the action of R_2 and R_3 until the next sweep retrace.

The pulses produced by the oscillator are amplified by VT_2 , rectified by VT_3 , and stored in the input filter condenser. Because very little current is needed, it is possible for a low-capacity

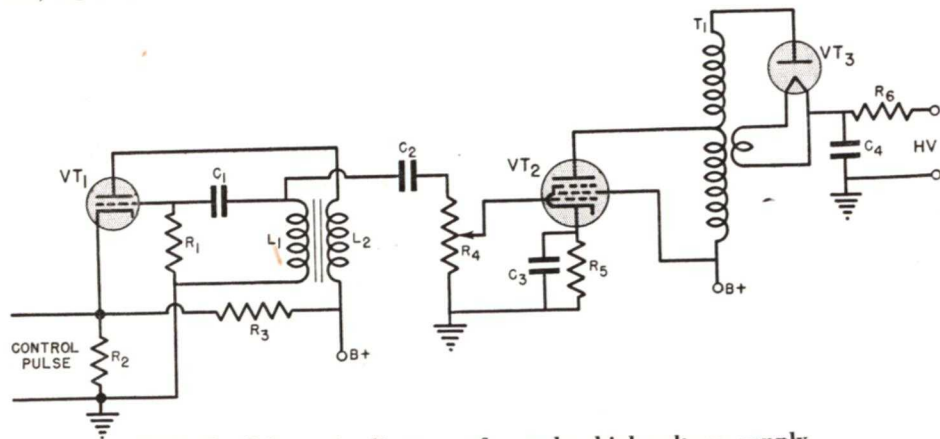

FIG. 5. Schematic diagram of a pulse high-voltage supply.

condenser to hold this charge reasonably well during the long time interval from pulse to pulse.

Since this power supply cannot operate at all unless a trigger pulse comes from the horizontal sweep, the high voltage will be removed from the picture tube at once if anything happens to block the operation of the sweep. Furthermore, the oscillator is allowed to operate only during the time of the sweep retrace. Since the face of the picture tube is kept blank during that interval by the pedestal and the sync pulse, any interference that might be produced by the oscillator will be invisible. Therefore, this circuit eliminates both the objections we found to the r.f. supply.

Another respect in which this pulse supply is better than the r.f. supply is that its output is not dependent upon resonance and therefore is not subject to variations caused by frequency drifts. The step-up transformer T_1 depends upon its turns ratio, not on resonance, for the voltage step-up. The output is controlled by the variable resistor R_4 , the setting of which determines the amount of signal fed to the grid of the pulse amplifier.

Of course, more parts are used in this supply than in an r.f. type, but its advantages have made it popular in spite of its greater cost.

THE FLY-BACK SUPPLY

You will recall that when the horizontal sweep amplifier tube of an electromagnetic sweep system cuts off, the energy stored in the horizontal deflection yoke produces a half-sine-wave oscillatory surge of very high amplitude. This current flows through the secondary of the horizontal sweep output transformer and induces a high voltage in the primary. As a result, a peak plate voltage of 5000 or 6000 volts is applied to the horizontal out-

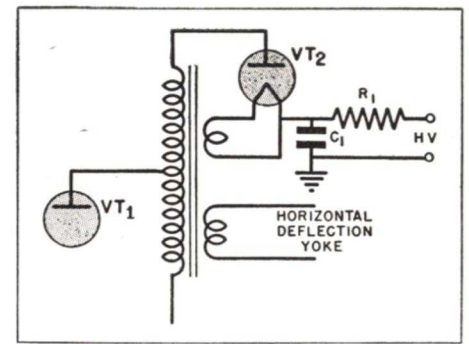

FIG. 6. Schematic diagram of a fly-back high-voltage supply. This supply can be used only in sets using electromagnetic deflection.

put tube in the usual circuit arrangement of this type. By adding a few more turns to the primary winding, as shown in Fig. 6, we can easily arrange for a voltage of from 9000 to 12,000 volts to be developed across the full primary winding. Therefore, in an electromagnetic system, we can get the high voltage directly from the horizontal sweep circuit simply by adding a few more turns to the primary of the horizontal output transformer and adding a small secondary to supply the filament voltage for the high-voltage rectifier. Obviously, this is by far the most economical power supply arrangement, since it entails mostly only a redesign of the horizontal output transformer. The only new parts needed are a rectifier tube and a filter.

Besides being a very inexpensive power supply, it has the advantage of operating only during the retrace time, when the screen is dark. If anything happens to the horizontal sweep oscillator circuit that makes the sweep fail to operate, the high-voltage pulse will not be generated either.

The only basic difficulty with this power supply is the fact that the amount of voltage produced depends on the amplitude of the horizontal sweep, which of course must be adjusted to get the proper picture width.

In most sets, this problem is solved by using a dual amplitude control—one a size control in series with the deflection yoke, and the other a control that varies the input or drive to the horizontal sweep amplifier. It is usually possible to find settings of these controls that will let you get the proper high voltage and the desired picture size.

This system is usable, of course, only in a set that has a horizontal deflection yoke—it cannot be used with electrostatic tubes. It differs in this respect from the other systems discussed, all of which can be used with either kind of picture tube.

HIGH-VOLTAGE DISTRIBUTION

When an electrostatic picture tube is used, a voltage divider is usually connected across the high-voltage supply to furnish the necessary voltages for all the elements within the picture tube. This is almost invariably done when a 60-cycle high-voltage supply is used, because this supply can furnish all the required currents very easily.

A typical basic voltage divider of this kind is shown in Fig. 7A. It is of course nothing but a series of resistances, arranged to give the proper voltage division, and also arranged to act as a bleeder across the power supply. When the supply is turned off, this bleeder permits the filter condensers to discharge.

A modification of this circuit is shown in Fig. 7B. As you know, the horizontal sweep output tube used with an electrostatic tube requires a rather high plate voltage (but very little current). If the power supply can furnish the needed current, the plate supply for this sweep amplifier can be obtained from the voltage divider.

Of course, all the elements of elec-

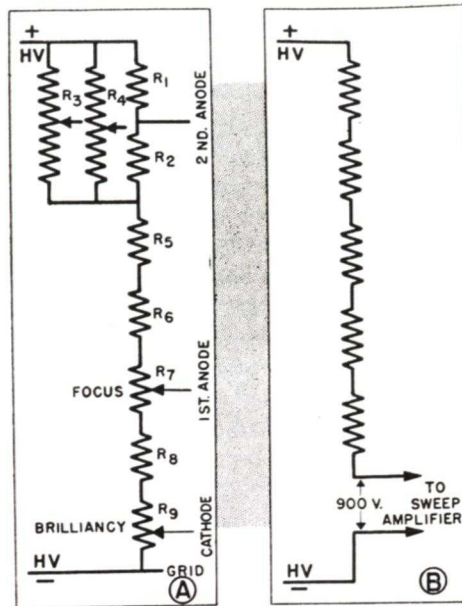

FIG. 7. Typical voltage-divider circuits used with electrostatic picture tubes.

tromagnetic picture tubes could be similarly supplied. Here, however, it is much more common to supply the first anode and the bias voltages of the picture tube from somewhere in the low-voltage supply (normal B supply) and to reserve the high-voltage supply purely for use between the second anode and the cathode as an accelerating voltage. This reduces the load on the high-voltage supply and also insures that the picture tube will go off if the low-voltage supply fails. A voltage divider is seldom used with such a supply. For safety, however, there may still be a bleeder that will discharge the filter condensers soon after the supply is turned off.

EXTRA-HIGH VOLTAGES

The power supplies we have discussed up to now are the kinds that are commonly used to produce voltages under 10,000 volts. Much higher accelerating voltages are necessary for the larger direct-view tubes and for projection tubes, however. Most of

the larger direct-view tubes require from 12,000 to 18,000 volts for proper operation, and most of the projection tubes used in home receivers need from 25,000 to 30,000 volts. (Voltages as high as 80,000 volts are used in some of the very large theater-size projection units.)

Such high voltages are secured in home receivers by using a pulse or fly-back supply in combination with a voltage-doubling or voltage-tripling circuit. This arrangement makes it unnecessary to use a transformer and a rectifier capable of handling extremely high voltages, both of which would be expensive.

The most popular form of voltage-multiplying circuit is shown in Fig. 8. Transformer T_1 is the output transformer for either the fly-back or pulse circuit and supplies pulses for the high-voltage supply. The resistance R_1 is the low-voltage bleeder; it is so low in resistance that it serves only to complete the circuit from C_1 to T_1 insofar as the high-voltage supply is concerned. Here is how the circuit works:

On the first pulse, rectifier VT_2 charges condenser C_1 to the full output voltage rating of T_1 through the path shown in Fig. 9A. When the pulse cuts off, there is a relatively long period (during the horizontal

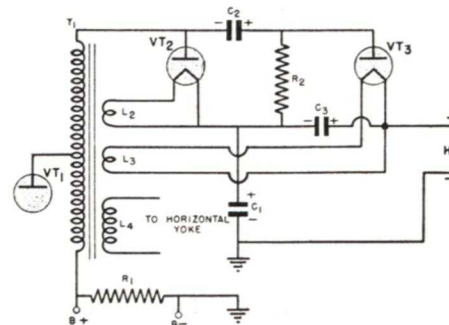

FIG. 8. A voltage-doubler circuit commonly used in home projection sets.

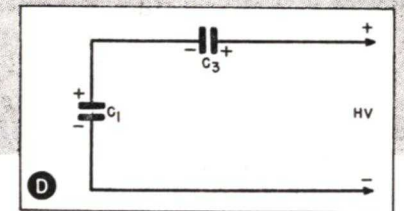
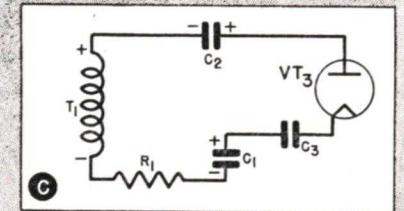
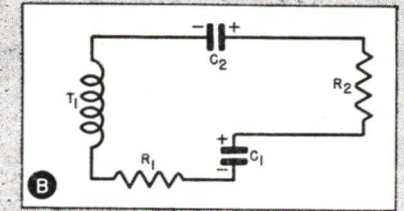
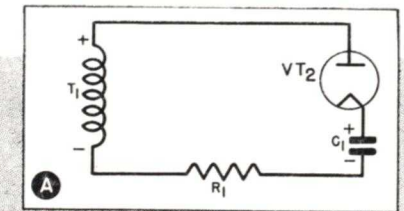

FIG. 9. This series of drawings shows how the voltage doubler shown in Fig. 8 works.

trace time) in which there is no voltage pulse. As Fig. 9B shows, C_1 is always connected across C_2 through paths consisting of R_2 on one side and R_1 - T_1 on the other. During the time that VT_2 is off, C_1 discharges somewhat, charging C_2 with the polarity shown. (After several cycles of operation, the voltage across C_2 becomes practically equal to that across C_1 .)

Now, on the next forward pulse, when the upper end of transformer T_1 is positive, VT_2 again conducts to recharge C_1 . At the same time, voltage is applied to VT_3 through the path

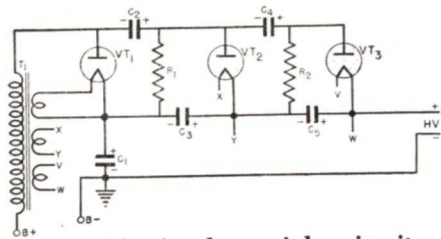

FIG. 10. A voltage-tripler circuit.

shown in Fig. 9C. The voltage applied is the sum of the pulse voltage across T_1 plus the voltage across C_2 and minus the voltage across C_1 . Since the voltages across C_1 and C_2 are equal and opposite, the voltage developed across T_1 is what is applied to VT_3 . This tube then conducts, allowing the full T_1 voltage to be applied to C_3 . As a result, C_3 is charged to the same voltage as C_1 is.

As Fig. 9D shows, the high-voltage output is the voltage across C_1 and C_3 in series. Hence, each condenser supplies half the voltage: if the output is, let us say, 20,000 volts, the voltage across C_1 is 10,000 volts, and the voltage across C_3 is likewise 10,000 volts. Hence, neither of these condensers has to have an extremely high voltage rating, which means they can be relatively inexpensive. That is an important feature of this circuit: in some other voltage-doubling circuits, at least one condenser has to be able to withstand a higher voltage.

This feature is even more important if the voltage must go up to 30,000 volts or more. A voltage tripler, using the same basic circuit (Fig. 10), is used to produce such voltages. In the circuit in Fig. 10, conduction of VT_1 initially charges C_1 . Then, while VT_1 is off, C_1 charges C_2 . On the next pulse of the input voltage, VT_2 conducts, charging C_3 ; on the next, C_3 charges C_4 ; and on the next, VT_3 conducts, charging C_5 . All five condensers in the circuit then have the same volt-

age across them. The high-voltage output is the sum of the voltages across C_1 , C_3 , and C_5 .

Notice that filament-type rectifier tubes are used in the circuits in Figs. 8 and 10, thereby eliminating the cathode-to-heater leakage problem that would exist if rectifiers having separate cathodes were used. Separate filament windings, insulated from each other by high-voltage insulation, must be used to supply these filaments.

In the circuits in Figs. 8 and 10, the high-voltage supply usually feeds into a filter resistor and from it directly to the second anode of the picture tube. If the tube is glass, as you know, the output filter condenser is formed by the coatings inside and outside the

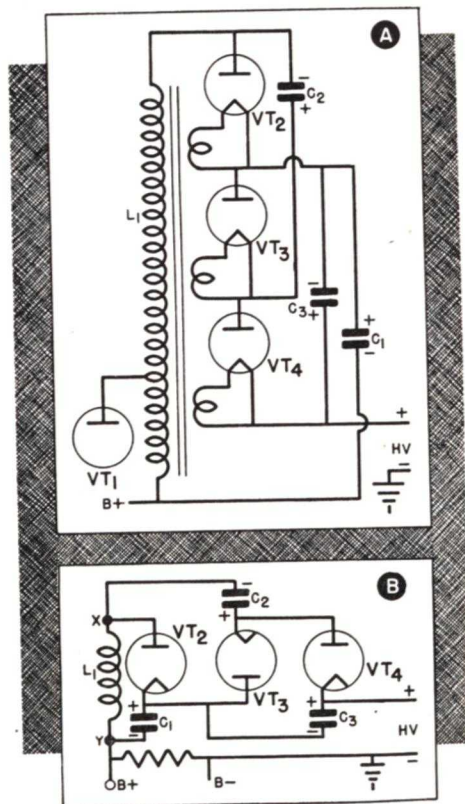

FIG. 11. The action of the voltage-tripler circuit (part A) is shown in part B.

funnel of the picture tube, which are separated by the glass of the funnel. The inner coating is connected to the second anode within the tube, and the outer coating is grounded.

Another form of voltage tripler is shown in Fig. 11. This circuit uses fewer parts than the one in Fig. 10, but two of the condensers must have twice the voltage rating needed in the other circuit. This supply, which is unusual in that it is driven by a sine-wave voltage instead of by pulses. Although the amplifier VT_1 is driven by a pulse from a blocking oscillator, it excites L_1 , which acts as a resonant tank circuit and, by fly-wheel action, produces a sine-wave voltage that is applied to the tripler circuit.

The voltage-multiplying action is shown in Fig. 11B. When the polarity of the oscillatory tank voltage makes the upper end (X) of L_1 positive, current will flow through the rectifier tube VT_2 and thus charge condenser C_1 to a voltage equal to that across the coil (about 8500 volts).

When the polarity of the oscillatory voltage reverses so that Y is positive with respect to X, the voltage across

L_1 plus that across C_1 is applied to VT_3 , causing VT_3 to pass current. When VT_3 conducts, C_2 is charged; since the applied voltage is equal to the sum of the voltage across C_1 and L_1 , C_2 is charged to about 17,000 volts and must be rated accordingly.

On the next reversal of the oscillatory cycle, when X is positive with respect to Y, the conducting path is from the source L_1 through condenser C_1 , condenser C_3 , tube VT_4 , and condenser C_2 back to the source. If you trace this path, you will see that the polarities are such that the voltages across L_1 and C_1 buck each other; as a result, C_3 is charged by the voltage across C_2 , meaning that it is charged to twice the source voltage.

The output high voltage is the sum of the voltages across C_3 and C_1 ; in other words, it is twice the source voltage plus the source voltage, or three times the source voltage. As we pointed out earlier, this tripler uses fewer parts than the one in Fig. 10, but both C_2 and C_3 in Fig. 11 must have at least twice the voltage rating needed for any of the condensers in the other circuit.

Low-Voltage Power Supplies

The high-voltage power supply that we have described is intended primarily to furnish the accelerating voltage for the picture tube. In a set using an electromagnetic picture tube, all other stages, including the low-voltage elements of the picture tube, require normal B voltages from a separate supply. In a set in which an electrostatic tube is used, the high-voltage supply may also supply the lower operating voltages for the picture tube and perhaps the plate volt-

age for the output sweep amplifier. However, all other stages require normal B supply voltages.

Just as in standard radio receivers, there are two basic forms of B supplies—one that uses a power transformer and one that does not. Let's see how the B supply of a TV set is different from the basic types with which you are familiar.

TRANSFORMER SUPPLIES

Fig. 12 shows a basic full-wave rectifier-filter-divider arrangement like

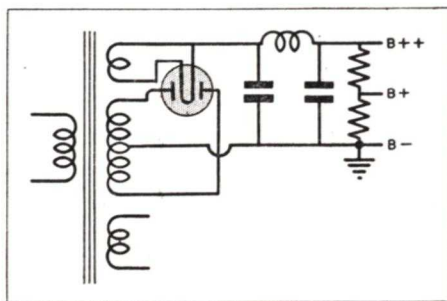

FIG. 12. Basic full-wave rectifier circuit.

that used in a standard radio receiver, and Fig. 13 shows a typical transformer power supply of a TV receiver. Let's analyze the latter supply to see how it differs from the former.

One major difference is that two rectifier tubes in parallel are used in the TV supply. This is necessary because a TV set has three or four times as many tubes as the average radio has and therefore uses much more current.

Notice that one plate of each tube is connected in parallel with the corresponding plate of the other tube. It would also be possible to connect the two plates of each tube in parallel, thereby making each tube a high-power half-wave rectifier, and then use the two tubes in a full-wave circuit. If this were done, however, and one tube

should fail, we would get half-wave rectification and consequently hum and a considerably reduced output. With the arrangement shown in Fig. 13, failure of one tube will overload the other one but will not cause hum, because we will still get full-wave rectification. Therefore, the circuit will continue operating until the second tube fails.

The filter arrangement is standard except that condensers are used in parallel to furnish the very high capacity needed to filter when the current demand is high. Thus, C_1 and C_2 form an 80-mfd. input capacity, and C_3 and C_4 give an output capacity of 120 mfd.

The voltage divider is made up of resistors R_1 to R_7 inclusive, plus the focus coil. Different amounts of B-supply voltage are available from the taps that are above ground potential; the taps below ground potential furnish bias voltages.

A large number of electrolytic by-pass condensers are used to provide additional filtering. Notice that nearly every tap is heavily by-passed. The bias taps are not by-passed in the power supply, but additional by-passing is used in the receiving circuits to which the bias voltages are fed. This extra by-passing helps to reduce hum

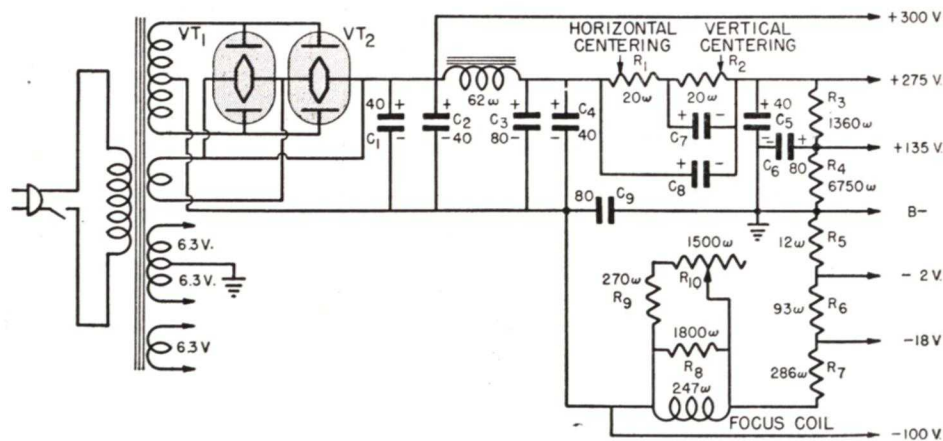

FIG. 13. Typical TV low-voltage supply using a power transformer.

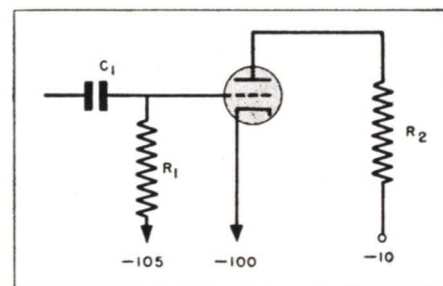

FIG. 14. Although all the elements of this tube are connected to negative voltage sources, there is a normal relationship between the cathode, grid, and plate voltages.

and interaction between stages.

The voltage divider resistors are designed to draw a rather high current so as to stabilize the output voltages at the various terminals. Since the focus coil must have a high current flowing through it for it to be effective, it is placed in the circuit at a point where all of the bleeder current plus the B supply current for all of the tubes (except for the amount that returns through the -100-volt lead) will flow through it. In this set, the focus is adjusted by varying the resistance in parallel with the focus coil and thus changing the current through it. This adjustment is not provided in some sets; in these, the focus is changed by moving the coil on the neck of the picture tube.

Most tube circuits get their B-supply voltage from the +275- or +135-volt tap, and the cathode returns are made through ground to the terminal at the junction of R_4 and R_5 . Fixed biases are usually taken from the -2- and -18-volt taps.

The -100-volt tap permits a higher voltage to be applied to certain circuits, such as the sweep output circuit. For example, if the plate of a tube is connected to the +275-volt tap and its cathode to the -100-volt tap, the total voltage between these two elements is $275 + 100$ or 375 volts.

Remember that the voltage applied between any two elements of a stage is equal to the voltage difference between the elements. For example, it is not at all uncommon to have an arrangement like that shown in Fig. 14 in which all of the tube elements apparently go to negative voltage terminals. However, this just means that each voltage is negative with respect to ground. The plate of the tube is at -10 volts, whereas the cathode is at -100, so the plate is 90 volts positive with respect to the cathode. Since the grid is at -105 volts, it is negative with respect to the cathode by 5 volts. It is not uncommon to find an arrangement of this sort in TV circuits, particularly when a d.c.-coupled video amplifier is used.

From what we have said, you can see that a television B-voltage supply in which a transformer is used is not very much different from those used in radio sets. Even the filament supply is relatively ordinary. The circuit shown in Fig. 13 is a little unusual in that the major filament winding produces a voltage of 12.6 volts. This winding has a center tap, however, so each half furnishes 6.3 volts, which is what most of the tubes in the set use. This design is used in some sets because there is some economy in making one continuous winding with a tap on it instead of making two separate insulated windings, although the latter construction is also common. In some sets, also, a 12.6-volt supply is needed for one or two tubes: this can be gotten by connecting the tube across the full winding.

TRANSFORMERLESS SUPPLIES

A power transformer of the kind just described, which can handle powers up to 500 watts, is large, heavy, and expensive. Bulk, weight, and manufacturing costs are reduced in many TV

sets, particularly the smaller ones, by using transformerless supplies similar to those used in a.c.-d.c. radios. In such TV sets, the high B-supply current requirements are met by using rectifier tubes in parallel and by using selenium rectifiers.

These selenium rectifiers consist of "washers" coated with selenium, which has the property of conducting far better in one direction than in the other. They are satisfactory, if not perfect, rectifiers, and they are small

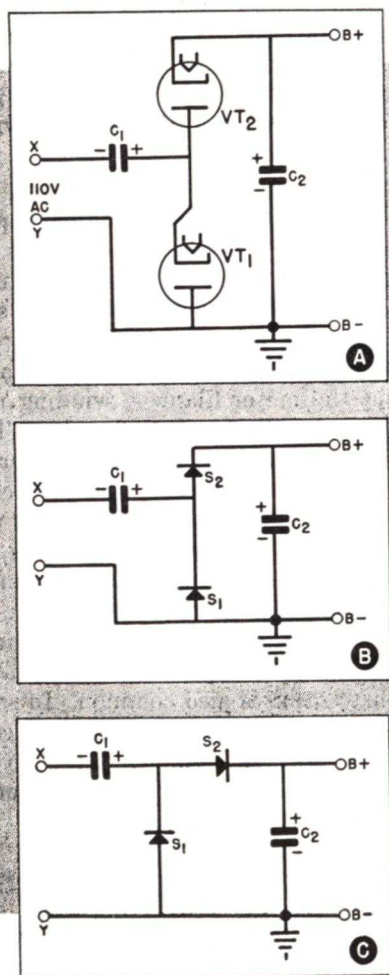

FIG. 15. Typical transformerless TV low-voltage supplies using voltage-doubler circuits.

and easy to mount in any position on or underneath the chassis.

A TV receiver requires B voltages that are at least twice the usual power-line voltage, so voltage doubling is always used in transformerless TV supplies. In fact, voltage triplers and even quadruplers are used.

Fig. 15A shows the usual voltage doubler, which operates like the one described earlier. When the source voltage makes terminal Y positive with respect to X, VT₁ conducts, charging C₁ to the source voltage with the polarity shown. When the polarity of the source reverses, the line voltage plus the voltage across C₁ are applied to VT₂, causing it to conduct and thus charging C₂ to about twice the line voltage. Since both C₁ and C₂ have relatively high capacities (120 to 150 mfd.), they are able to retain considerable charge and consequently remain fairly constant in voltage even when a certain amount of power is drawn from them.

The selenium rectifier circuit shown in Fig. 15B is exactly like the tube circuit in Fig. 15A in its operation. (The "arrow" of the selenium symbol corresponds to the tube plate; the "plate," to the tube cathode.) This latter circuit has been redrawn in Fig. 15C to show how it is usually represented in the schematic diagram of a set.

Incidentally, the ground symbol in these circuits represent the set chassis, not an actual ground. As in any a.c.-d.c. power supply, a condenser must be used between the chassis and any external ground as a protection in case the wrong side of the power line is connected to terminal Y.

Fig. 16 shows a somewhat more elaborate transformerless power supply in which two rectifier tubes and a selenium rectifier are used. With this arrangement, it is possible to get four different B voltages. One is the same

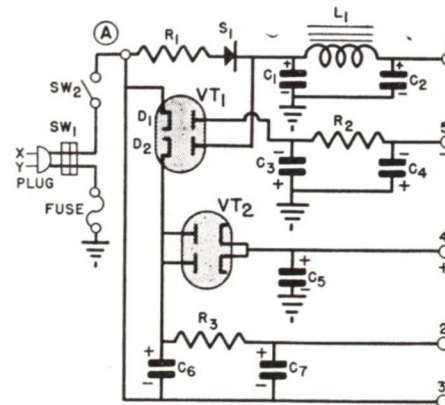

FIG. 16. A transformerless power supply that can furnish four different B voltages.

as the power-line voltage; the others are respectively twice, three times, and four times the line voltage. Each of these voltages can be fed independently to the circuits requiring it.

The selenium rectifier S₁ is used to provide half-wave rectification in the circuit from the power plug through R₁, S₁, and C₁ to ground, and thus back to the power line. The d.c. voltage developed across C₁ (which is approximately equal to the line voltage) is filtered by L₁ and C₂ to produce an output voltage across C₂ that is about equal to the line voltage.

There is also a connection from the junction of rectifier S₁ and condenser C₁ to the plate of diode D₂ of the rectifier tube VT₁. The cathode of this rectifier tube goes to an input filter condenser C₆, the other terminal of which is connected to one side of the power line. This is a voltage-doubler circuit: when the polarity of the power line voltage is such that terminal Y is positive with respect to X, the line voltage will add to the voltage across C₁ and charge condenser C₆ through diode D₂ to approximately twice the power-line voltage. The doubled output voltage across condenser C₆ is then filtered by the combination R₃-C₇

and appears between terminals 2 and 3.

On the next half-cycle, when X is positive with respect to Y, the power-line voltage will add to the voltage across C₆ to charge C₅ through VT₂ to three times the power-line voltage. This tripled voltage appears between terminal 4 and ground.

Finally, diode D₁ of VT₁ acts as a half-wave rectifier to permit condenser C₃ to charge directly from the power line. The voltage across C₃ is filtered by R₂-C₄ and appears between terminal 5 and ground. The connections are such that terminal 5 is negative with respect to ground. Therefore, the voltage between terminals 5 and 4 is equal to four times the line voltage. This quadrupled voltage is used for the sweep output amplifier in the electrostatic set using this supply.

Fig. 17 is a final example of an elaborate power-supply system. The trans-

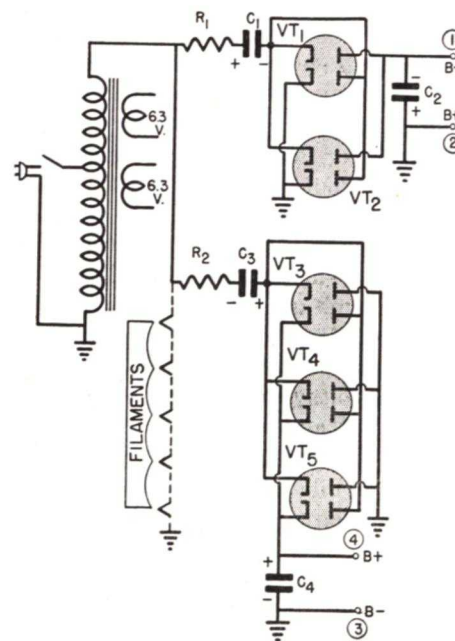

FIG. 17. A compromise power supply that uses an auto-transformer, principally to supply tube filament voltages.

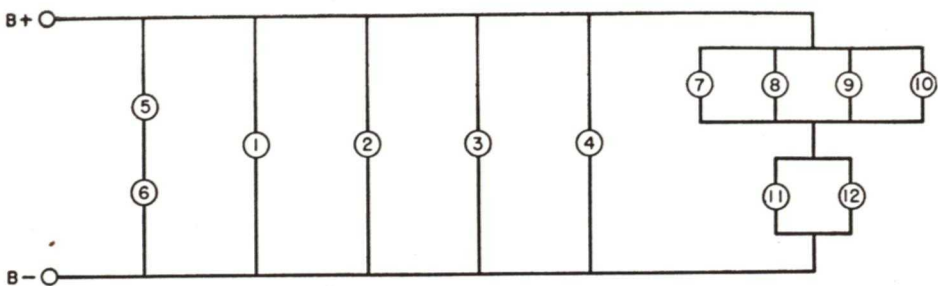

FIG. 18. Typical voltage distribution system used with a transformerless supply.

former used in this circuit is an autotransformer, the output of which is only slightly higher than the power-line voltage. It is used primarily to supply filament voltages for the tubes in the set.

The upper two rectifiers act as a voltage doubler. One section of one tube is in parallel with a corresponding section of the other tube so that twice the current can be handled. On one half-cycle, condenser C_1 is charged; on the next, the voltage across C_1 adds to the line voltage and charges C_2 to twice the line voltage. Notice that the output voltage of this section of the power supply is negative with respect to ground.

The lower three tubes also make up a voltage doubler, this time with three sections—one of each tube—in parallel so that very high currents can be handled. This section supplies the normal B voltage to the receiver. Since its output is positive with respect to ground, a voltage equal to four times the line voltage is available between terminals 1 and 4 of the supply.

B-Supply Distribution. Since the current available from any voltage-multiplier circuit is rather limited, it is common practice not to use a bleeder with transformerless supplies but to arrange the tube circuits insofar as possible to use the full output of the B supply. If some stages are to operate at lower voltages, the stages may be connected so as to divide the volt-

age between them, as shown in Fig. 18. Here, the stages numbered 1, 2, 3, and 4 are connected directly across the full B supply. Stages 5 and 6, however, are in series across the supply. This arrangement is permissible if the two stages are to operate from half the total supply and draw identical currents.

In the remainder of the circuits, the stages 7, 8, 9, and 10 are in parallel, and their currents flow through the stages 11 and 12. In this case, the plate current sum of the first four must equal that of the latter to give the proper voltage division.

Fig. 19 shows how two tubes may be connected in series across the power supply. In this case, the d.c. path, starting from B-, goes to the cathode of VT_1 , then through this tube and its load resistor R_2 to the cathode bias resistor R_4 of VT_2 . From here, the path is through tube VT_2 and its load resistor R_5 back to B+.

Fig. 20 shows a typical example of

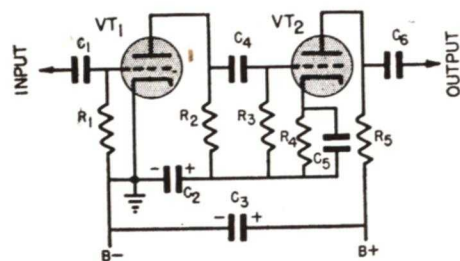

FIG. 19. How two tubes may be connected in series across the B supply.

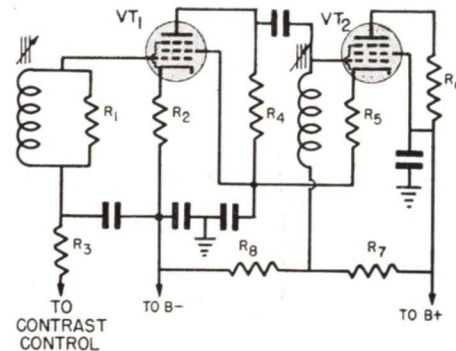

FIG. 20. An example of the use of the circuit shown in Fig. 19 in a practical receiver.

this kind of connection in the i.f. section of a TV receiver. Once again the two tube plate circuits are in series across the B supply. (Trace from B- through R_2 , VT_1 , R_4 , R_5 , VT_2 , and R_6 to B+.) Notice that the contrast control is connected to the grid of VT_1 . If you change the bias on this tube by changing the setting of the contrast control, the plate current through VT_1 will change. The plate current of VT_2 will then also have to change, since the two are in series, and the same current must flow through all the elements in a series circuit. Therefore, adjusting this control changes the current and hence the gain of two stages simultaneously.

FILAMENT DISTRIBUTION SYSTEMS

When a power transformer is used, the tube filaments are usually operated from filament windings, just as they are in standard radio receivers. When a transformerless type of B supply is used, on the other hand, the tube filaments are usually in some series-parallel arrangement so that they may be operated from the power line directly, as they are in a.c.-d.c. radios.

The power supply shown in Fig. 17 uses a compromise arrangement in which the filaments of all the tubes

except the rectifiers are supplied from the 6.3-volt windings on the transformer. The five rectifier tubes, which have 25-volt filaments, are connected in series across the "high-voltage" winding of this transformer—which, in this case, is practically the same as connecting the five filaments in series across the power line.

Notice that the manufacturer has obviously made a compromise. He could have used rectifiers having higher current ratings had he wanted to use tubes with 5-volt filaments. Doing, so, however, would have made it necessary for him to have added another filament winding to the transformer; furthermore, he would have had to use a much larger transformer to take care of the extra power needed.

In those receivers that have no power transformer at all, the tubes are of course chosen to have the proper filament voltage and current ratings so that a reasonable filament string can be set up. Of course, it is impossible to connect so many tubes in a single string, particularly since the picture tube, which has a fairly high filament-current rating, must be in the string. Therefore, you will ordinarily find that the filaments are in some series-parallel arrangement such as is shown in Fig. 21. Here, five tubes in series with R_1 form one string, and eight tubes plus R_2 form another. These two series strings both pass current through tubes VT_1 and VT_2 . Tube VT_1 has a current rating twice that of any tube in the series strings so

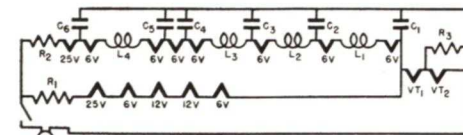

FIG. 21. Some series-parallel arrangement of this sort is always used in transformerless sets to supply the proper filament voltages.

that it can carry both currents. Tube VT_2 does not have as high a rating, so it is shunted by resistor R_3 , which carries the extra current.

The resistors R_1 and R_2 have the proper resistances to reduce the supply voltage to the amount required by each series string. They also usually have a ballast action so that they will protect the tubes when the set is first turned on. This is necessary because the tube filaments have low resistance when cold, so a high current can flow through them until they warm up. If this were allowed to happen, the lives of the tubes would be shortened. To prevent it, the series resistors used are

usually either ballast tubes or special "Globar" resistors so made that their resistances decrease as they get warm. The cold resistances of these resistors are high enough to limit the starting current to a safe value; then, as the tubes warm up, the resistances of the ballast resistors decrease enough to permit the filaments to get the proper currents. If these burn out, it is important to replace them with exact duplicates.

The by-pass condensers and r.f. choke coils shown in Fig. 21 act as filters on the r.f. and i.f. tube filaments to prevent stray coupling between stages along the filament leads.

The Sound Channel

In general, the sound channel of a TV receiver resembles very closely the i.f., detector, and audio portions of an f.m. sound receiver. There are some differences between them, however, which we shall now discuss.

First, let's make sure you understand the difference between the so-called "standard" or "conventional" and the "intercarrier" or "intermodulation" sound systems.

STANDARD RECEIVERS

Fig. 22A shows in block-diagram form the arrangement of stages in the standard TV receiver. In this set, the mixer-first-detector (or converter) produces two i.f. frequencies—a video i.f. carrier that is amplitude-modulated by the video signal and sync pluses, and an audio i.f. carrier that is frequency-modulated by the sound signal. The transmitter radiates two separate carriers with these modulations, and the local oscillator beats with both to produce the two new i.f. carriers. The sound i.f. carrier is 4.5

mc. below the video i.f. carrier when the oscillator is above the frequency of the incoming signal, as it is in most receivers. If, for example, the video i.f. carrier is 25.75 mc., the sound carrier will be 21.25 mc. In most modern TV receivers the video carrier is somewhere between 25 and 46 mc., and the sound carrier is therefore somewhere between 21 mc. and 42 mc.

Since the sound and video carriers

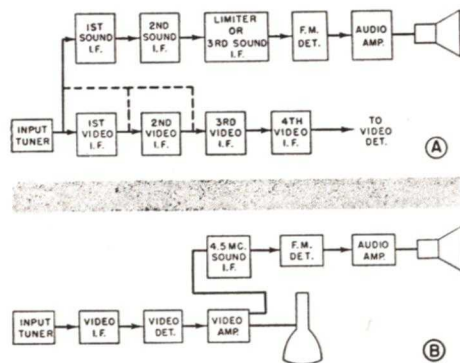

FIG. 22. Block diagram of a standard TV receiver (A) and of an intercarrier set (B).

are two entirely separate signals, the two can be separated by tuned circuits. In some sets, the sound take-off point is right at the output of the converter. However, if greater gain is desired, the sound may be taken out after the first or second video i.f. amplifier, in which case these stages must have a sufficiently broad response to handle both carriers.

After the sound i.f. is removed from the video i.f. path, it is applied to a regular i.f. amplifier having a pass-band of about 300 kc. Usually, there are two sound i.f. amplifier stages, followed by one or two limiter stages, the latter of which feeds into a discriminator. In some sets, a ratio detector is used instead of a discriminator, in which case the limiter stages may be converted into regular sound i.f. amplifiers or may be missing altogether. In general, however, there will be at least three stages in the sound i.f. portion of the set, including the limiter (if one is used).

From the discriminator, the sound signal passes through a normal two-stage audio amplifier before being applied to the loudspeaker. The power output stage may be push-pull in the larger sets.

INTERCARRIER SYSTEM

At first glance, the only difference between the intercarrier system shown in Fig. 22B and the "standard" shown in Fig. 22A appears to be that the sound take-off is at the output of the video amplifier in the former. Actually, in the intercarrier system, there is rarely more than one stage in the sound i.f. portion, which is why the circuit is popular with the manufacturers of smaller receivers.

In the intercarrier system, the two carriers pass through the video i.f. amplifier together. When both are applied to the video detector, a beat of

4.5 mc. occurs between the two carriers. This difference frequency is frequency-modulated by the sound signal and somewhat amplitude-modulated by portions of the video signal. This new 4.5-mc. carrier then passes through one or more stages of the video amplifier. At some point, it is trapped out of the video path and applied to the 4.5-mc. sound i.f. section. The sound i.f. is tuned to 4.5 mc. regardless of the video and sound i.f. carrier frequencies. This 4.5-mc. signal with its complex modulation is amplified by the sound i.f. and then fed to either a discriminator or a ratio detector. Here any amplitude modulation is wiped out, with the result that only the frequency modulation produces an audio signal. (Of course, if any stage in the chain handling the 4.5-mc. signal is overloaded by this or any other signal, cross-modulation products will be set up with the result that some of the video modulation may cause a hum from the loudspeaker.)

The audio amplifier used with the intercarrier system is just like that found in the standard system.

To sum up, the major differences between the standard receiver and the intercarrier type are:

1. In the standard receiver, the sound take-off point is in the video i.f. amplifier, either immediately following the converter or after the first or second video i.f. amplifier stage. In the intercarrier system, the sound take-off is in the video amplifier.

2. In the standard receiver, the sound i.f. amplifier is tuned to a frequency 4.5 mc. below that of the video i.f. amplifier. There are usually two amplifying stages followed by a limiter or two in the sound i.f. section. In the intercarrier system, the sound i.f. amplifier is tuned to 4.5 mc. and rarely has more than one stage.

3. Since the video section of a set

using the intercarrier system handles the sound signal also, it must have a greater band width than is necessary in a standard set.

Whether the standard or the intercarrier system is used, the sound signal must be kept out of the picture as much as possible. In the standard set, the video i.f. stages following the point of sound take-off always have one or two sound i.f. traps. These traps, which are tuned to the sound i.f. frequency, are intended to attenuate the sound signal so that very little of it will reach the video detector. If even a small portion does reach the video detector, the 4.5-mc. beat that is a characteristic of the intercarrier system will be produced, and in addition, because of slope detection in the video detector, the sound modulation will be converted into an amplitude signal. Both these signals can appear in the picture. The 4.5-mc. beat will produce a very fine-grained dot pattern, and the audio signal will produce bars across the picture. Some sets have a 4.5-mc. trap in the video amplifier to remove the 4.5-mc. "grain" pattern.

In spite of the sound i.f. traps, the sound signal may reach the detector if the set is not properly tuned to the station or the circuits are out of alignment. This is why sound bars show up when the fine tuning control is improperly set.

In the intercarrier system, 4.5-mc. grain traps are usually found at or following the point of the sound i.f. take-off. Some of the small (7") sets using the intercarrier system do not use grain traps, since the fine-grained pattern produced by the 4.5-mc. beat is not too apparent at the normal viewing distance for a 7" tube.

PRODUCING THE INTERCARRIER BEAT

The f.m. detector is supposed to remove all amplitude variations from

the i.f. beat signal produced in the intercarrier system. To make it easier for the detector to do so, the amplitude modulation in the beat signal is kept as small as possible. This is done by taking advantage of two facts:

1. When two signals are allowed to beat together, and one signal is very much weaker than the other, the amplitude of the beat signal is approximately equal to the amplitude of the weaker signal and practically independent of the amplitude of the strong signal.

2. If either of two beating signals is frequently-modulated, the complete frequency modulation appears in the beat signal.

These characteristics of beat signals are made use of in the intercarrier system by reducing the strength of the sound i.f. carrier so that it is far weaker than the video i.f. carrier when the two signals are applied to the video demodulator. As a result, the 4.5-mc. beat has the full f.m. or sound modulation but very little amplitude modulation from the picture signal.

The sound i.f. carrier can be reduced to the desired strength (about 5% or 10% of the video i.f. carrier strength) in an intercarrier set by using video i.f. stages having the response shown in Fig. 23A. Notice that this response has a small flat plateau around the sound i.f. carrier frequency; as a result, there is little possibility of slope detection of this carrier and consequently little chance of cross modulation. The shape and amplitude of the response at this frequency are determined by the alignment of the i.f. amplifier and by the judicious use of traps. These traps are not tuned directly to the sound carrier; instead, they are tuned near and to either side of it to produce the desired response.

Because of the difficulty of securing the response shown in Fig. 23A, the

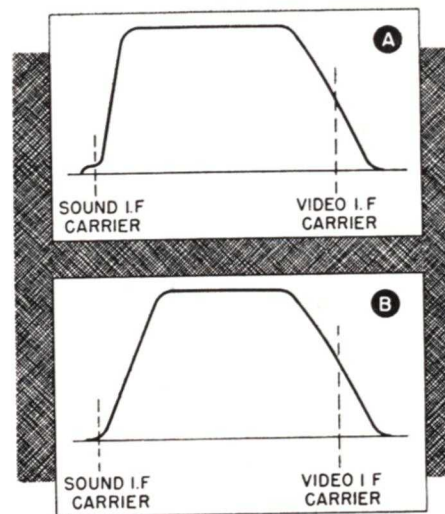

FIG. 23. The ideal video i.f. response of an intercarrier set is shown in part A. The response shown in part B is more commonly used in practice.

one pictured in Fig. 23B is more commonly used in intercarrier sets. There is no plateau at the sound-carrier frequency in this latter; instead, the response is merely made low at this frequency. Cross modulation can therefore occur in a set in which this arrangement is used.

Since the sound i.f. carrier is held at a fairly low value in passing through the i.f. section in the intercarrier system, most of the amplification it is to get must be received in some later section. Usually the video amplifier is used to furnish the desired gain so that it will not be necessary to add a stage to the 4.5-mc. amplifier.

There are a few disadvantages to the intercarrier system that have limited its acceptance. One is that during bright portions of a picture, the video carrier is low, with the result that more of the picture signal gets mixed with the audio signal. During such bright portions or during any overmodulation of the picture signal, therefore, the sound signal may have hum in it. It will be basically a 60-

cycle hum, since 60 cycles is the frame repetition rate of the picture signal, and the effect causing the hum occurs in each frame.

Another disadvantage is that if the picture carrier disappears at any time because of difficulty with the picture at the transmitter, the sound will automatically disappear too.

Furthermore, the picture contrast control will also control the sound level. This is not desirable, but there is no easy way to avoid it unless the set has a.g.c., in which case the contrast control can perhaps be placed in a video stage beyond the point of sound take-off.

An advantage of the intercarrier system is that it is far less subject to difficulty because of oscillator drift than the standard system is. In the conventional system, any considerable drift in the oscillator frequency may shift the sound i.f. outside the pass band of the sound i.f. section, distorting the sound or wiping it out altogether. If this occurs, it will be necessary to retune the oscillator, which is done either by adjusting the fine tuning control or by realigning the receiver.

In the intercarrier system, the 4.5-mc. sound i.f. is not produced by the local oscillator. The only thing that an oscillator shift can do is change the relative levels of the sound and video i.f. carriers to such an extent that the sound signal may have an undesired amount of video signal in it; or, if the shift is very large, the sound beat signal may become somewhat weakened. In general, however, the oscillator can drift far more in an intercarrier system than it can in the conventional system before the sound signal is upset to any great extent.

Now that you have a general understanding of the two systems, let's look at the circuits in a little more detail.

TYPICAL CONVENTIONAL SOUND I.F. SYSTEM

In the conventional system, as we have said, the sound i.f. is extracted from the video signal path either immediately following the converter stage or after the first or the second video i.f. stage. It is taken off by inserting a trap circuit tuned to the sound i.f. in the video signal path and using the signal developed across this trap at the source for the first sound i.f. stage.

Sound Take-off. Fig. 24 shows several different sound take-offs. In the arrangement shown in Fig. 24A, the sound trap L_2-C_2 is tuned to the sound i.f. carrier frequency. This trap is coupled to the coil L_1 , which is the plate load for the mixer stage and resonates with distributed circuit ca-

pacities. The resonant circuit L_2-C_2 absorbs a considerable portion of the sound carrier energy that is in the plate circuit of the mixer and therefore reduces the amount of the sound signal that is applied to the video i.f. stages.

To have the greatest effect, this trap circuit should have a high Q, so it must be loaded as little as possible by the grid circuit of the first sound i.f. amplifier, to which it is connected. This loading is minimized by taking the input for the sound i.f. stage from a tap on the coil.

The arrangement shown in Fig. 24B is somewhat similar. Here, the trap L_3-C_3 is coupled to the primary circuit L_2-C_2 and once again absorbs the sound signal. The video signal is passed on through L_4-C_4 .

In the arrangement shown in Fig.

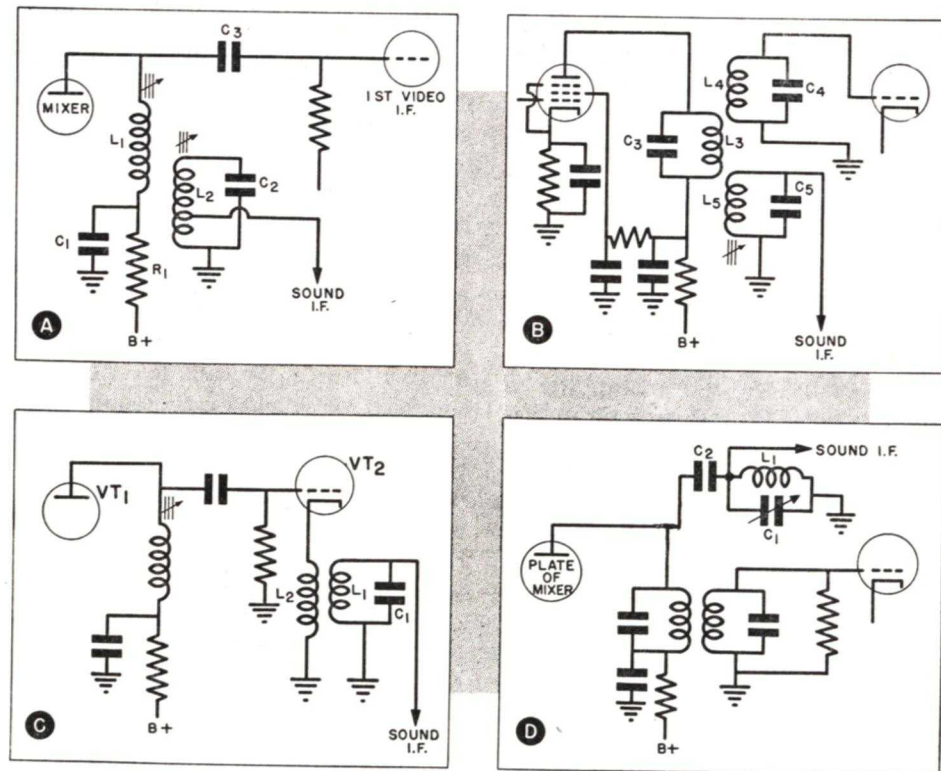

FIG. 24. Various sound take-off systems used in conventional TV sets.

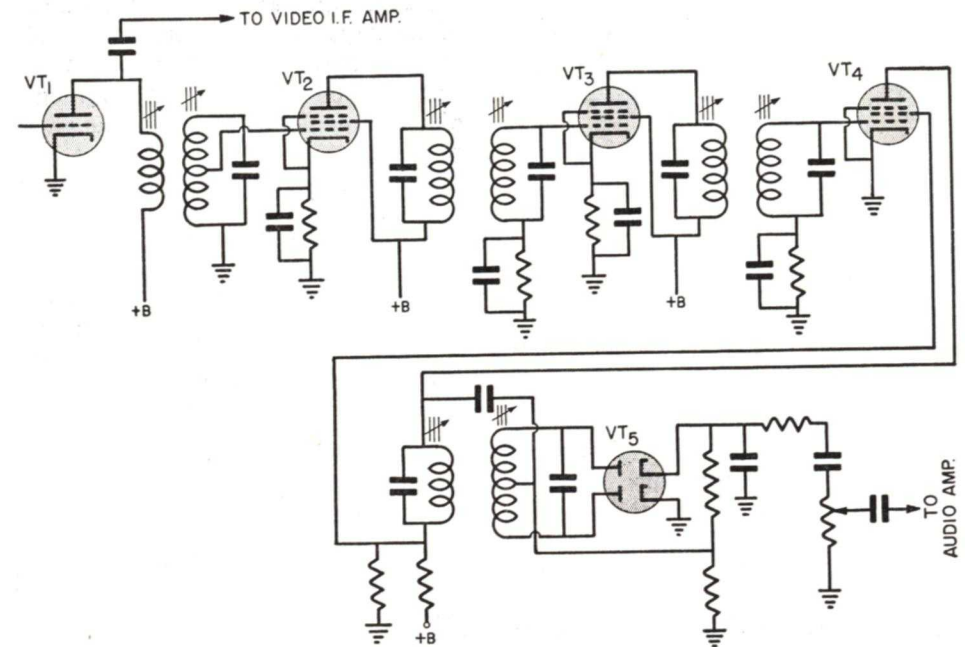

FIG. 25. Typical 3-stage sound i.f. system used in conventional sets.

24C, the sound trap L_1-C_1 is coupled to coil L_2 , which is in the cathode circuit of VT_2 . The resonant circuit extracts the sound i.f. signal. Further, the reflected effect of this circuit makes L_2 a fairly high resistance for 4.5-mc. signals. There is therefore an appreciable drop across L_2 at the beat-signal frequency. Since L_2 is in the cathode circuit of VT_2 , this drop produces degeneration; as a result, only a minimum of the 4.5-mc. audio signal is passed on to the following video stages.

The arrangement shown in Fig. 24D is somewhat similar to that in B, except that the trap L_1-C_1 is capacitively coupled through C_2 to the plate tank coil instead of being inductively coupled to it.

Notice that two desirable effects are produced in each of these circuits when the sound take-off trap is properly resonated: 1, a maximum sound signal is fed to the sound i.f. stages; and 2, a

minimum sound signal is passed on to the succeeding video i.f. stages.

If the sound take-off point is at the output of the mixer or after the first video i.f. stage, three or four sound i.f. stages are always used. If the take-off point is beyond the second video i.f. stage, however, one less sound i.f. stage may be used.

Sound I.F. A typical conventional 3-stage sound i.f. system is shown in Fig. 25. Here, tubes VT_2 and VT_3 are the sound i.f. amplifiers, feeding through band-pass tuned circuits that are 200 kc. to 300 kc. wide. (If the signal for this sound i.f. section is taken from the second video i.f. stage, one of these amplifiers will probably not be used.) Tube VT_4 is a limiter stage of the sort used in most f.m. receivers that use a discriminator as the video detector. Tube VT_5 is the discriminator. Both the limiter and the discriminator will be described briefly later in this text.

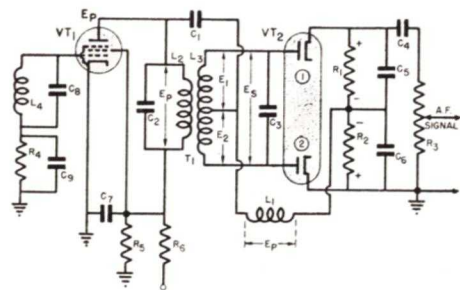

FIG. 26. Schematic diagram of a typical f.m. limiter-discriminator section.

A ratio detector is used in some receivers instead of the limiter-discriminator combination. We shall describe this detector in a moment.

Limiter. Let's review the action of a limiter and a discriminator very briefly, using the typical circuit shown in Fig. 26. (This will be a quick review of a rather complicated subject: if you do not understand it all, read the earlier sections of your Course in which this circuit is described in detail.) Here, the VT₁ stage is much like any other i.f. amplifier stage except that the bleeder resistor R₅ and the series resistor R₆ make the screen grid and plate voltage on this stage very low—only about 48 volts. These low operating voltages make the upper knee of the characteristic response of this stage very low and sharp.

The grid circuit contains the grid leak and condenser combination R₄-C₉. Condenser C₉ tends to keep charged to the average voltage of the peaks of the input signal, thus maintaining a steady bias on the tube that will keep its output constant even if the input signal undergoes sudden momentary changes in amplitude. This condenser therefore minimizes the effect of noise when the signal is weak.

When the signal is strong, the low voltages applied to the screen and plate effectively wipe out amplitude changes in the input signal. Because

these voltages are so low, the output of the stage will not go above a certain limit no matter how strong the input signal becomes. Thus, if the strength of the f.m. signal is great enough to drive the stage to its full output, any increases in signal strength caused by noise accompanying the f.m. signal will not affect the output. In other words, the noise will be wiped out by the limiter stage. (In an intercarrier system, this limiting action will also tend to wipe out any portions of the video signal that may accompany the sound carrier.)

Discriminator. The transformer T₁ transfers the signal from the limiter VT₁ to the discriminator circuit, in which tube VT₂ is used. The primary circuit L₂-C₂ is tuned to the incoming signal. This signal is transferred to the tuned secondary circuit L₃-C₃ and is also fed through C₁ so that it appears across L₁.

The voltage induced in L₃ produces the voltages E₁ and E₂ across the two sections of this coil. These voltages are always equal in magnitude and 180° out of phase with each other.

The voltage applied to diode 1 of VT₂ consists of E₁ plus the signal E_p that exists across L₁. (The path from L₁ to the cathode of this diode is through the by-pass condenser C₅, which is virtually a short at the frequencies involved.) Similarly, the voltage applied to diode 2 of VT₂ consists of E₂ plus E_p, the path being completed through by-pass condenser C₆. At resonance and with no modulation, therefore, equal voltages are applied to the diodes; as a result, equal and opposite currents flow through the resistors R₁ and R₂. The voltage between the two cathodes of VT₂ is zero under such conditions.

Off resonance (that is, at frequencies other than the resting or no-modulation frequency), however, the

voltages applied to the two diodes are not equal. When the applied signal swings below the setting frequency, the voltage applied to diode 1 of VT₂ becomes greater than that applied to diode 2; consequently, a greater current flows through R₁ than flows through R₂. As a result, the voltage drops across the two resistors become unequal, and a net voltage appears across them that has the same polarity as the drop across R₁. Conversely, when the applied signal swings above the resting frequency, a net voltage appears across R₁ and R₂ that has the polarity of the drop across R₂.

Thus, swings of the applied signal above and below the resting frequency produce an a.c. voltage across R₁-R₂. This voltage feeds through C₄ to appear as the output voltage across R₃. At each instant, the value of this output voltage is proportional to the deviation of the incoming signal frequency from the resting frequency. Thus, it is an audio signal voltage that corresponds to the one used to modulate the f.m. transmitter.

THE RATIO DETECTOR

Some manufacturers prefer to eliminate the limiter circuit and instead use detector circuits that are themselves insensitive to amplitude variations. The only circuit of this kind that is found commonly in television sound systems is the ratio detector. Fig. 27 shows a typical example.

At first glance, this circuit is very similar to that of the discriminator, you have just studied. However, there are two important differences—one of the diode tubes is reversed, and a charge storage condenser C₄ has been added to the circuit.

At the resting frequency, the voltage E_p adds to E₁ and to E₂ to make both diodes conduct equally, just as in the discriminator. Because of the way

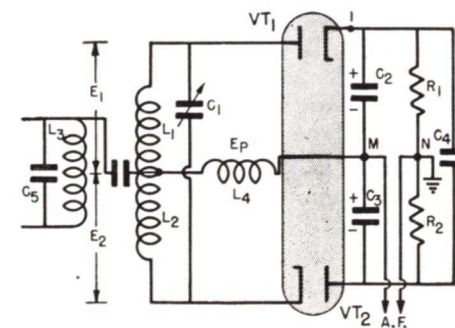

FIG. 27. A typical f.m. ratio detector.

they are connected, both diodes conduct at the same time, charging the equal condensers C₂ and C₃ to the polarities shown. At the same time, condenser C₄ is charged to a voltage that is equal to the sum of the voltages across C₂ and C₃.

The size of condenser C₄ is such that the voltage across it cannot change very fast. As a result, the voltage at the midpoint N of the voltage divider R₁-R₂ will remain relatively constant at a voltage equal to half that across C₄.

To take an example, let's assume that the voltage across C₄ is 10 volts, and that only the resting frequency is being applied. In this case, the voltages across C₂ and C₃ will each be 5 volts, so point M will be 5 volts negative with respect to point 1, which we will take as a reference point. Since point N will also be 5 volts negative with respect to point 1, there will be no net voltage difference between points M and N, as shown in Fig. 28A.

Now let's suppose that the incoming signal varies in frequency. When it shifts in one direction, one diode will conduct more than the other, so that the instantaneous voltages across condensers C₂ and C₃ will no longer be equal. However, their sum will remain that of the charge across C₄—namely, 10 volts—because the voltage across C₄ cannot change readily. Let's assume that diode VT₁ momentarily

conducts more current so that the voltage across C_2 goes up to 8 volts, and the voltage across C_1 drops to 2. There will now be a voltage difference of 3 volts between points M and N, as shown in Fig. 28B, because the voltage between point 1 and point M has changed, while that between point 1 and point N has not.

When the incoming frequency swings in the other direction, the opposite action will occur—the voltage across C_3 will become greater and that across C_2 will become less. As a result, the voltage relationship shown in Fig. 28C will be produced.

The voltage difference between points M and N will therefore be an a.c. signal whose amplitude depends on the amount the incoming signal deviates from the resting frequency and whose frequency depends on the rate at which the deviation occurs. In other words, it will be a reconstruction of the audio signal that was originally used to modulate the f.m. carrier.

This circuit will not respond to amplitude variations in the input signal, because such changes will merely make both diodes conduct either more or less without making them conduct unevenly. As we have seen, the diodes

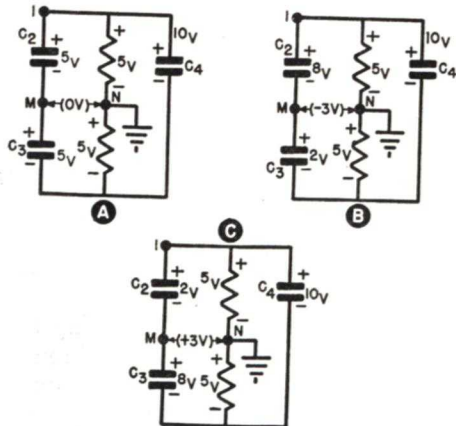

FIG. 28. This series of diagrams shows how a ratio detector works.

must conduct different amounts of current to make any voltage difference appear between points M and N, and this difference in their conduction can be produced only by a change in the frequency of the applied signal. Therefore, any amplitude variations caused by noise or a video signal accompanying the f.m. signal will not appear in the output of the circuit.

INTERCARRIER SOUND I.F. SYSTEM

When the intercarrier system is used for the sound, the 4.5-mc. beat can be taken right from the output of the video detector, but since it is necessary to increase the strength of the signal, the usual practice is to take this signal from the output of the video amplifier. Trap circuits are commonly used as sound take-offs.

Various forms of trap take-offs are shown in Fig. 29. In the simplest (Fig. 29A), a parallel resonant circuit L_2 - C_2 tuned to the 4.5-mc. carrier is placed in the grid circuit of the sound channel amplifier VT_2 and is fed through coupling condenser C_1 from the plate of the video amplifier VT_1 .

A disadvantage of this arrangement is that it does not reduce the amount of the 4.5-mc. carrier in the video signal. The circuit shown in Fig. 29B is more satisfactory in this respect. Here, the coupling condenser C_1 resonates with coil L_2 to form a series resonant circuit at 4.5 mc. At resonance, this circuit offers a minimum load for the video amplifier VT_1 , so the output of VT_1 at the 4.5-mc. carrier frequency is minimized. On the other hand, since this is a series resonant circuit, whatever 4.5-mc. signal does appear across it will produce a maximum voltage across L_2 for application to the sound amplifier.

The arrangement shown in Fig. 29C also minimizes the amount of the beat

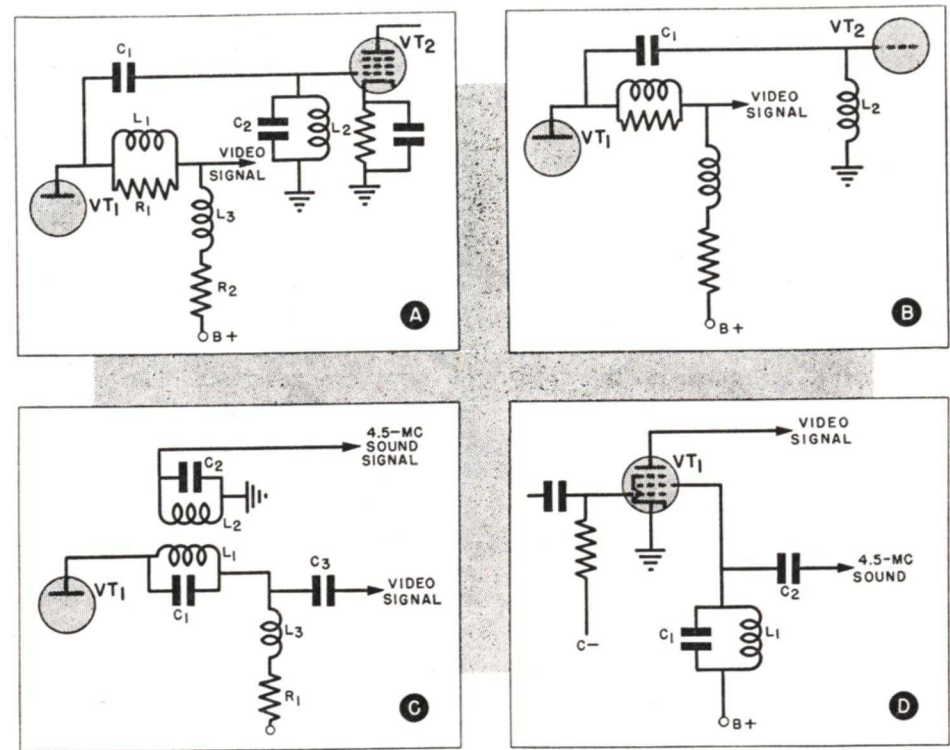

FIG. 29. Various kinds of sound take-off circuits used in intercarrier sets.

signal in the picture signal. Here, a parallel resonant circuit tuned to 4.5 mc. is connected in series with the load circuit of VT_1 . Most of the 4.5-mc. beat signal in the output of VT_1 is developed across this circuit, so very little is passed on through C_3 with the video signal. The sound carrier is fed to the sound amplifier from the resonant circuit L_2 - C_2 , which is tuned to 4.5 mc. and inductively coupled to L_1 - C_1 .

In the arrangement shown in Fig. 29D, the take-off circuit is in the screen-grid circuit of one of the video amplifier stages. It is possible to take the sound from here because any signal in the plate circuit also exists in the screen circuit. (Ordinarily, of course, we get rid of the signals in the latter circuit by by-passing the screen grid.) With this arrangement, there is a minimum of interaction between the sound and video circuits.

When the take-off systems shown in Figs. 29A and 29D are used, grain traps that are tuned to 4.5 mc. are needed in the stages following the sound take-off points to reduce the effects on the picture of this 4.5-mc. beat signal.

As we mentioned earlier, the 4.5-mc. sound amplifier in the intercarrier system usually consists of only a single stage (tuned to 4.5 mc. but otherwise like a conventional sound i.f. stage). It is usually followed by a ratio detector; if not, the single stage is adjusted to act as a limiter, and a discriminator is used.

In all TV sets, the sound detector is followed by a standard audio system. This is usually a high-gain audio voltage amplifier followed by a single-ended or push-pull pentode power amplifier that feeds the loudspeaker. These stages are identical with those found in the better sound receivers.

Automatic Gain Control

All TV receivers require a gain control, just as a sound receiver needs a volume control, because the signals from different stations are likely to be of different strengths at the receiving location. Within the range of normal signal levels, adjusting the gain of a TV set affects the contrast (range of grays from white to black), so the TV gain control is known as the "contrast" or "picture" control.

Since most of the video gain is obtained in the video i.f. amplifier, these stages are the logical ones in which to control the gain. The simplest contrast control is an adjustable bias on two or three of the video i.f. stages. This can be either a self-bias or a

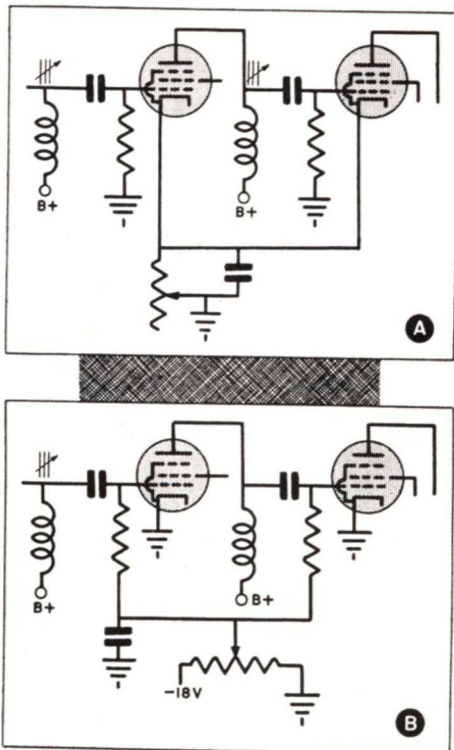

FIG. 30. Two ways of adjusting the bias on video i.f. stages to control the video gain.

bleeder bias arrangement, as shown in Figs. 30A and 30B. It may not be possible to use this system to control very strong signals, however, because if the bias on the i.f. stages is increased too much, the stages may be operated so near cut-off that distortion will be introduced. Therefore, it is desirable to control the gain of the r.f. stage also on very strong signals. The gain of the r.f. stage should not be reduced on normal signals, however, because the r.f. gain is needed to overcome converter noise.

In general, it is desirable to have an arrangement that permits the bias to increase first on the i.f. stages, then, as the overload level is approached, to increase on the r.f. stage. Manufacturers differ in the ways they arrange controls to achieve this—some use dual controls, others use voltage dividing and bleeding arrangements. Fig. 31 shows one example.

The i.f. bias network is shown in Fig. 31A. Basically, this consists of a bleeder R_1 , R_2 , and R_3 arranged across a C-bias section of the bleeder resistor in the power supply. The bias applied to the i.f. grids is adjusted by the setting of R_2 —as the slider is moved to the right in this figure, the bias becomes more negative.

The voltage divider R_4 - R_5 is arranged so that the i.f. grid bias can never be as much as the total voltage across R_2 , for reasons that we shall explain shortly.

The complete biasing arrangement that also supplies bias to the r.f. grid circuit is shown in Fig. 31B. When the slider on R_2 is at the left, so that there is little bias applied to the grids of the i.f. tubes, the diode VT_1 conducts heavily because a positive voltage is applied to it from the B+ source

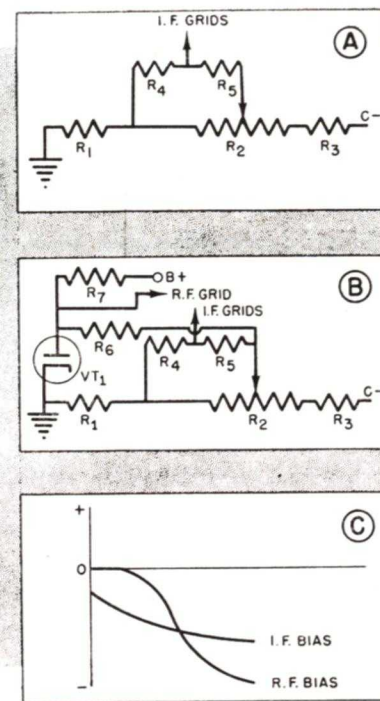

FIG. 31. These drawings show the workings of a contrast control that affects the bias on both the r.f. and video i.f. stages.

through R_7 . Since R_7 is a high resistance compared to the diode resistance, there is very little voltage drop across the diode, so the grid of the r.f. tube (which is connected to the plate of VT_1) is effectively at ground potential and has practically no bias.

As the setting of R_2 is changed, however, the negative voltage across R_2 is applied to the diode. Eventually, this voltage will cancel that applied from the B supply; the diode will then cease to conduct. When this happens, the grid of the r.f. tube will be tied through R_6 directly to the slider in R_2 , and the full voltage at that setting of R_2 will be applied to this grid. As the slider is moved more to the right, as it must be if the strength of the incoming signal is high, the bias on the grid of the r.f. tube will become greater than the bias applied to the i.f. tubes; in

fact, it will approach the cut-off bias for the r.f. tube rather rapidly.

The manner in which the two bias voltages vary is shown in the curves in Fig. 31C. As you can see, the i.f. bias increases gradually and steadily with the rotation of the contrast control. The r.f. bias is zero for a time, then increases rapidly with further rotation of the control. Thus, it is possible to arrange the circuit so that overloading can be prevented, yet at the same time to keep the r.f. gain at maximum until it is necessary that it be reduced.

Although this contrast control arrangement permits the gain to be adjusted manually, there are a number of good reasons why an automatic, self-adjusting control would be better. For one thing, it is annoying to have to readjust the contrast control every time a new station is tuned in. More important, many receiver owners find it difficult to set the control properly. This means that the receiver must be designed so that the video and sync circuits following the i.f. stages will be capable of operating from signals that may not be of the optimum strength, which calls for design compromises. Also, although we do not have the fading with TV signals that is common in distant a.m. reception, we can have a variation in signal due to swinging antenna and transmission lines. Finally, the TV signal may at times undergo violent fluctuation because airplanes or moving automobiles happen to pass through the signal transmission path.

For all these reasons, it is desirable to put into the TV set an automatic gain control (a.g.c.) system, comparable to the a.v.c. system of an ordinary radio, that will arrange the gain of the set so that the signal fed to the video detector will be relatively constant under all normal conditions. When such a system is used, resetting the contrast

control is an infrequent and simple operation.

Let's see how practical a.g.c. systems work in TV receivers.

BASIC A.G.C.

An a.g.c. system must operate from some component of the signal that is proportional to the strength of the carrier, since it is the carrier strength at any moment that determines what the gain of the set should be at that moment. The only part of a TV signal that meets this specification is the height of the sync pulses. These extend upward from the no-signal or black level pedestal by a fixed percentage of the carrier strength. (This percentage may be different for different transmitters, but is always the same for one transmitter.) If the carrier strength changes, the amplitudes of the peaks of these sync pulses from the black level and from the zero level will change proportionately.

There are two ways in which we can get a signal voltage from the sync pulses that we can use for a.g.c. One way is to strip the sync pulses from the video signal and use the pulses themselves, depending on the fact that their amplitude is proportional to that of the carrier. The other way is to use the peak value of the sync pulses above the zero level, since the height of these peaks is also proportional to the carrier amplitude.

Of course, the sync pulses exist during only a small fraction of the whole TV signal. If the pulses are to furnish a control voltage, therefore, we must find some way to make their effect last from at least one pulse to the next. This is most easily done by using the pulses to charge a condenser in an R-C network.

A simple a.g.c. circuit that uses the peaks of the sync pulses is shown in Fig. 32A. This consists of a diode rec-

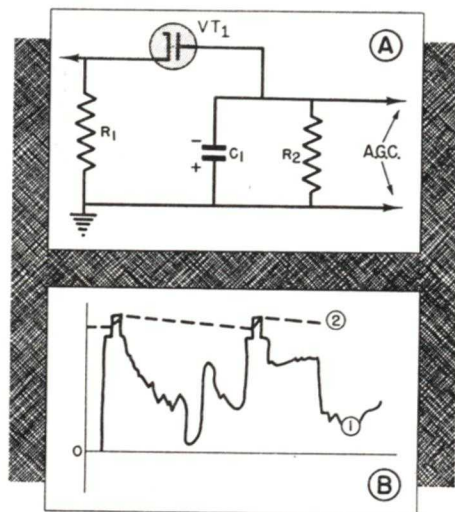

FIG. 32. A simple a.g.c. system.

tifier with a time constant filter C_1 - R_2 . When a TV signal like that shown by curve 1 in Fig. 32B is applied to R_1 , VT_1 conducts whenever the signal exceeds the charge stored in C_1 . Since the diode then has low resistance, C_1 charges rapidly up to the peak voltage of the sync pulses during the time that VT_1 conducts.

When the signal swings below the peak level, C_1 must then discharge through R_2 . This discharge is slow, since R_2 has a high resistance—so slow that C_1 discharges very little during the period of one line. At the end of this line, another sync pulse recharges C_1 at once to the full peak voltage. Therefore, the voltage across C_1 follows curve 2 in Fig. 32B, and, as you can see, remains nearly at the peak value at all times.

We can use the voltage across C_1 as an a.g.c. voltage by applying it to the video i.f. stages as a bias. When we do so, the bias on these stages will be proportional to the strength of the carrier; it will increase on strong signals and decrease on weak ones, thereby varying the gain so that the signal applied to the video detector will be very nearly constant.

Selecting the proper time constant for the R_2 - C_1 circuit in Fig. 32A is somewhat of a problem. There are reasons for making it short and others for making it long. If we make it short (that is, use a value of R_2 that will permit C_1 to discharge fairly rapidly), the circuit will be able to follow more rapid fluctuations in the signal and will offer more freedom from noise interference than it will if we make the time constant long. On the other hand, a short time constant may make the set lose vertical sync. Let's see why these effects can occur.

First, let's suppose a sharp noise pulse that is higher than the peak of the sync pulse is received. The gain of the set will automatically and suddenly be reduced by the a.g.c. circuit. If the time constant is long, C_1 will hold its high charge for several lines, during which time the gain of the set will be reduced. Therefore, the use of an a.g.c. circuit having a long time constant means that there will be "holes" (large blacked-out areas) in the picture when noise is present, whereas the picture on a set with a manual contrast control would show nothing more than nearly un-noticeable short black streaks under the same conditions.

Suppose, on the other hand, that we make the time constant quite short. Condenser C_1 will then discharge considerably in between the horizontal sync pulses, so the average a.g.c. voltage (the voltage across C_1) will be relatively low. When a vertical sync pulse (which is much broader than a horizontal pulse) is received, however, C_1 will be charged for a much longer time than it is during the horizontal pulses; consequently, the average voltage across C_1 will increase during the vertical pulse. This means that the gain of the set will be reduced during the vertical pulse, an effect that may make the set lose vertical sync.

Since synchronization is extremely important, a simple a.g.c. system like this is usually made slow-acting (that is, given a long time constant). Such a system will compensate for signal changes like those produced by switching stations, but cannot take care of rapid fluctuations, and of course is extremely poor when noise is present. Therefore, it is not used much; instead, more elaborate systems that are not bothered excessively by noise and do not interfere with the vertical sync are preferred. Before we discuss these circuits, let's see where the a.g.c. system normally gets its signal and what is done with the control voltage produced.

Obviously, the a.g.c. rectifier can be connected to the output of the video detector. However, it is undesirable to load the video detector circuit or to shunt it by the capacities of the tube used in the a.g.c. circuit, so a connection farther along in the video amplifier is often preferred. An important point is that we must obtain the signal from a point where it has its normal d.c. level so that the pedestals will be lined up (since otherwise the peaks of the sync signals will not be proportional to the carrier strength). If we use an a.c. coupling, a d.c. restoration circuit must be incorporated in the a.g.c. circuit or used ahead of the a.g.c. rectifier.

The d.c. voltage that is obtained as a result of the a.g.c. action is usually applied as a bias to the i.f. amplifier stages, appropriate R-C decoupling networks being used to prevent coupling between the stages. The signal may also be applied to the r.f. stage ahead of the converter, in which case some arrangement is generally used so that the bias applied to the r.f. stage will be unaffected on weak signals but will increase rapidly on strong signals.

There is usually some control in the

a.g.c. network to set the threshold beyond which it operates. This may be the contrast control for the set or may be a separate non-operating control mounted at the rear of the set.

In the latter case, a contrast control is used in the video amplifier at some point beyond the take-off point for the a.g.c. voltage. This is generally a control that can be used to vary the bias on one video stage by a limited amount. When this arrangement is used, the a.g.c. system is adjusted to deliver normal signal to this stage; the contrast control can then be used by the set owner to adjust the picture to the contrast he wants. It should not be necessary to use the control to prevent overloading or to compensate for changes in signal strength.

NOISE LIMITER A.G.C.

One way of getting the proper a.g.c. action and a certain amount of freedom from noise at the same time is to use a limiter circuit in the a.g.c. When a system of this sort is properly arranged, the a.g.c. circuit responds to normal signal levels, but any very sharp and sudden increase is clipped by the limiter so the a.g.c. voltage does not rise unduly. The limiter is

therefore much like the amplitude limiter that is used with an f.m. signal.

A typical limiter a.g.c. system is shown in Fig. 33. This circuit has three special features. First, an initial bias set up by the contrast control gives an operating point about which the a.g.c. system performs. Second, it is arranged so that the a.g.c. bias voltage will be divided between the r.f. stage and the i.f. stages on strong signals. Finally, it is relatively insensitive to the changes produced when noise pulses are received. Let's study each of these actions.

The initial bias (the bias when no signal is tuned in) is set by R_6 , the contrast control, which is part of the voltage divider R_5 , R_6 , and R_7 that is connected between ground and a negative voltage source. The grid of VT_2 is tied through R_4 , R_3 , and R_2 to the negative terminal of this supply, so the cathode of VT_2 is made positive with respect to the grid by an amount determined by the setting of the contrast control. At the same time, the cathode of VT_2 is negative with respect to ground. Since the plate of this tube is tied to ground through R_8 and R_9 , it is positive with respect to the cathode; as a result, there is a plate current flow through R_8 and R_9 that produces

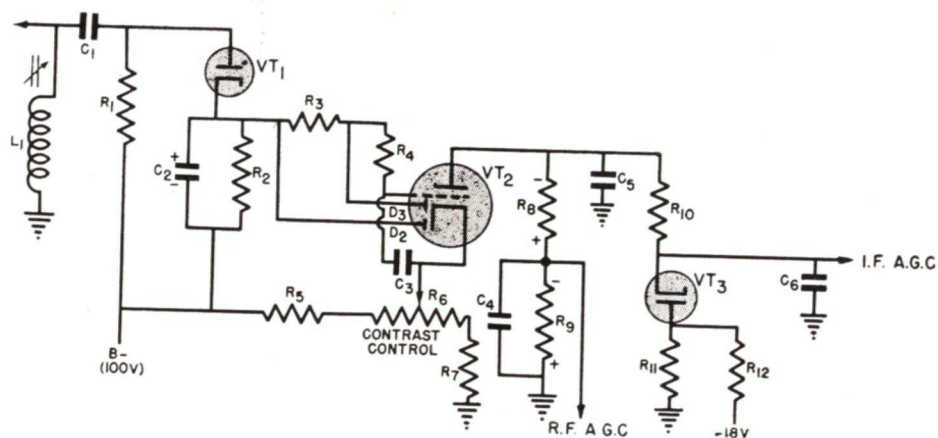

FIG. 33. Typical noise-limiter a.g.c. system.

voltage drops across these resistors having the polarities shown. The relatively small voltage across R_9 is applied as a bias to the r.f. tube; the entire drop across R_9 and the larger resistance R_8 is applied through the filter C_5 - R_{10} to the i.f. stages as a bias. (Of course, the amount of the bias that is applied to the i.f. stages will be affected if VT_3 conducts; but, as we shall see in a moment, this tube conducts only when the signal is strong.)

The initial setting can be changed, if desired, by adjusting the contrast control. Doing so varies the bias on the grid of VT_2 , thereby changing its plate current and therefore either increasing or decreasing the drop across R_8 and R_9 , as desired.

Now, let us suppose a signal of normal strength is tuned in. This signal appears across the video i.f. transformer L_1 and is applied through C_1 to the a.g.c. diode VT_1 . The basic a.g.c. action occurs in this diode circuit: VT_1 conducts on the peaks of the sync signal; and C_2 charges to the peak voltage each time VT_1 conducts, losing only a small amount of its charge through R_2 in between the sync pulses, so the voltage across C_2 follows the peaks of the sync pulses. As you can see from the diagram, the plate of VT_3 is usually slightly negative with respect to its cathode because it is connected to a point on the voltage divider R_{11} - R_{12} that is below ground. When the signal is very strong, however, the voltage across R_8 and R_9 will exceed the negative voltage applied to the plate of VT_3 , so this tube will conduct. When this happens, the voltage that is across R_8 and R_9 will divide between R_{10} and the resistance of VT_3 and R_{11} in series, and only the part across R_{11} and VT_3 will be applied to the i.f. stages as a bias. The current passed by VT_3 will remain constant even if the applied signal be-

comes stronger, so the voltage drop across VT_3 and R_{11} (in other words, the i.f. bias) will remain constant. The r.f. bias will increase if the signal becomes stronger, however, since this bias is the result of the flow of the plate current of VT_2 through R_9 . Thus, the i.f. bias increases in proportion to the strength of the applied signal until a certain critical signal strength is reached; if the signal then becomes stronger, the i.f. bias remains constant and the r.f. bias increases. As you learned earlier, this is the most desirable action for a contrast control.

Now let's see how the noise eliminating section of this circuit works. This section makes use of the diodes D_2 and D_3 , which form part of VT_2 .

As long as the strength of the received signal is normal, the voltage developed by the a.g.c. diode VT_1 across C_2 never equals the bias voltage developed across R_5 and that portion of R_6 that is in the biasing circuit. As a result, the diode plates D_2 and D_3 are always at least slightly negative with respect to the cathode, so they do not conduct.

If a sharp, high noise pulse comes along, however, the voltage across C_2 may exceed this bias voltage momentarily. When this happens, the two diodes are driven positive, and both conduct heavily. In effect, each diode acts as a short circuit across C_2 and thus drains off the additional charge that the noise pulse tries to place on this condenser. As a result, noise pulses are unable to produce more than a momentary change in the voltage applied to the grid of VT_2 .

Furthermore, the integrating circuit consisting of R_4 and C_3 also helps to limit noise effects. As you can see by examining the circuit, the voltage across C_3 is the bias that is applied to the grid of VT_2 . The R-C circuit consisting of R_4 and C_3 has a fairly long time constant: therefore, any sudden

exactly the same time, however, the voltage developed across L_3 drives the cathode of VT_2 negative. There are, therefore, two conflicting influences on the plate current of VT_2 : the bias applied to the grid tends to decrease the plate current, the voltage applied to the cathode tends to increase it.

Whether the plate current can change or not therefore depends on the *difference* between these two voltages. If the signal level is very low, the bias developed across R_2 will be small; then the high negative voltage applied to the cathode of VT_2 will produce a large pulse across R_3 , a large drop across R_5 , and hence a small drop across R_7 as the a.g.c. voltage.

As the signal becomes stronger, however, the bias developed across R_2 will reduce the size of the pulse across R_3 , thus causing less drop across R_5 and so permitting more plate current to flow through VT_4 to increase the drop across R_7 . Thus, the amount of a.g.c. voltage varies in accordance with the strength of the signal.

Since tube VT_2 conducts appreciably only during the horizontal sync pulses, any noise pulse that occurs in between these sync pulses is ignored. If a noise pulse happens to occur at the same time as the sync pulse, the following action takes place:

The noise pulse develops an even

higher bias voltage across R_2 than do the sync pulses. As a result, the pulse produced across R_3 is so small that it is less than the voltage across C_2 ; consequently, VT_3 does not conduct, and no charge is produced in the bias applied to VT_4 . Thus, this circuit tends to ignore noise under any circumstances.

Naturally, you are going to find many different kinds of a.g.c. networks in TV receivers. In general, however, each will adjust the gain of the set so that the signal applied to the video detector will be reasonably constant. Each will probably have either a limiter or a keying arrangement to make the circuit insensitive to noise.

There may or may not be an arrangement that will permit the a.g.c. bias to be distributed between the r.f. and i.f. stages. If there is, it will operate so that the bias applied to the r.f. stage will not increase on weak signals but will increase rapidly on strong signals to prevent overloading.

On any set in which a.g.c. is used, the contrast control does not need constant adjustment, but only occasional re-setting for unusual picture conditions. When the set is switched from station to station, or when noise or rapid fading occurs, a good a.g.c. system should maintain the output almost constant.

Lesson Questions

Be sure to number your Answer Sheet 57RH-3.

Place your Student Number on every Answer Sheet.

Send in your set of answers for this Lesson immediately after you finish them, as instructed in the Study Schedule. This will give you the greatest possible benefit from our speedy personal grading service.

1. Why is it necessary to shield an r.f. high-voltage supply?
2. Why cannot a high-voltage supply that is locked with the sweep produce visible interference in the set in which it is used?
3. Why are voltage-multiplying circuits used in preference to conventional supplies to produce voltages over 10,000 volts in home receivers?
4. Why are ballast tubes or Globar resistors used instead of fixed resistors in the filament strings of a.c.-d.c. TV sets?
5. In what *section* is the sound take-off point in (1) a standard TV set and (2) an intercarrier TV set?
6. What two effects will be produced on the picture of a standard TV set if all the sound signal is not trapped out before it reaches the video detector?
7. What two desirable effects result when the sound take-off circuit is properly resonated in a standard set?
8. Why is the 4.5-mc. beat signal usually taken from the output of the video amplifier instead of from the output of the video detector in an intercarrier set?
9. Why is it desirable to have the contrast control affect the gain of the r.f. stage as well as that of the video i.f. stages?
10. What undesirable effect is produced if the time constant of an a.g.c. system is (1) too short; or (2) too long?

Be sure to fill out a Lesson Label and send it along with your answers.



GOOD RESOLUTIONS

When you make a good resolution, put it into effect *at once*. To postpone it is deadly. Anything that can be done next month or next year can be done NOW—or at least a start can be made toward it.

Millions of people dream about doing fine, worthwhile things. But only a *few hundred* people ever get around to actually doing these things.

The *few hundred* may not be as smart as the others—may not be as talented, as capable, or as well educated. But they ACT and achieve concrete results—while the plans and good resolutions of *the millions* fade out into airy nothings.

Remember this when you make plans—when you make good resolutions. Put your plans and resolutions into effect *at once*. Get started!

J. E. Smith