

**TELEVISION
SYNCHRONIZING CIRCUITS**

Finish

56RH-3



NATIONAL RADIO INSTITUTE

WASHINGTON, D. C.

ESTABLISHED 1914

STUDY SCHEDULE No. 56

For each study step, read the assigned pages first at your usual speed, then reread slowly one or more times. Finish with one quick reading to fix the important facts firmly in your mind. Study each other step in this same way.

1. Introduction Pages 1-6

In this section, you first learn the general methods used to separate the sync signals from the video signal and to use them to control the sweep oscillators; next, you review the operation of R-C networks, which are widely used in sync separator circuits; and finally, you learn what constitutes a transmitted television signal.

2. Sync Clippers Pages 6-12

You study the various kinds of clipper circuits in this section.

3. Sync Amplifiers and Segregating Circuits. Pages 12-18

In the first part of this section, you study the amplifier chains that are often used in networks; in the second part, you learn how the horizontal and vertical sync pulses are segregated.

4. Sync Locking Circuits. Pages 19-28

Here you study various a.f.c. systems and a pulse-width system that are used to lock horizontal oscillators to the horizontal sync pulses.

5. Answer Lesson Questions, and Mail your Answers to NRI for Grading.

6. Start Studying the Next Lesson.

COPYRIGHT 1949 BY NATIONAL TELEVISION INSTITUTE, WASHINGTON, D. C.

(An Affiliate of the National Radic Institute)

1950 Edition

Printed in U.S.A.

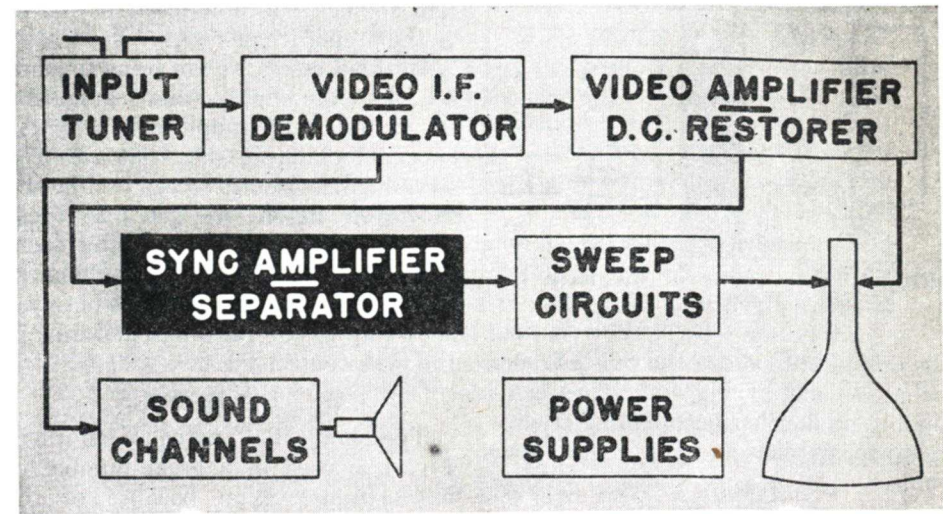

TELEVISION PICTURES can be produced properly only if we are able both to modulate the electron beam in the picture tube and to sweep the beam vertically and horizontally with sweep systems that can be locked with (controlled from) the transmitter. In previous Lessons, you have followed the picture signal to the grid of the picture tube and have learned how the sweep circuits operate. Now we are ready to see how it is possible to control the sweep circuits with the synchronizing pulses that are a part of the television signal as it comes from the transmitter.

As you have learned, the oscillators of television sweep circuits are made free running so that voltages will be produced to protect the face of the picture tube when no signal is tuned in. The frequency at which each runs free is approximately the correct one for the sweep circuit in which it is used. These oscillators are arranged so that they can be made to fall in step with the synchronizing signal, thus making the sweep generators follow the transmitter scanning and reconstruct the picture properly, element by element and line by line.

The signal at the output of the video detector contains the picture information that is used to determine the brightness of the spot. It also contains blanking pedestals, on each of which are the synchronizing pulses—one set of pulses for horizontal or line synchronization and another set for vertical or frame synchronization. Therefore, we must separate these pulses from the picture signal and then separate the line pulses from the vertical pulses. Once we have done so, we can obtain synchronization by applying the pulses to the sweep circuits.

As we shall show in this text, it is possible to separate the synchronizing pulses from the picture signal in a separator stage. Filter circuits may then be used to separate the two kinds of pulses from each other. Since there is more than one separation involved here, it is common practice to call the first operation "clipping," since effectively we "clip" the sync pulses from the rest of the signal. The operation of separating the two kinds of pulses is usually called "segregation."

The synchronizing pulse amplitudes may not be as high as is desired, the polarity may be wrong, and it may

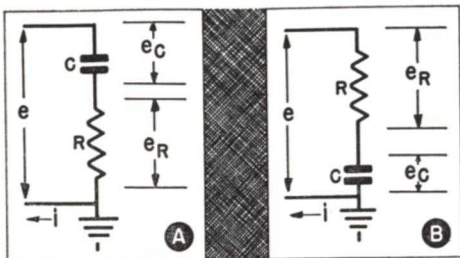

FIG. 1. Two forms of the basic R-C circuit.

be desirable to shape the pulses somewhat, so amplifying stages are commonly used either before or after clipping to amplify and correct the sync pulses.

In the simplest kind of synchronizing systems—known as “trigger” systems—the vertical and horizontal pulses are fed directly to the sweep oscillators after they have been segregated. These simplified trigger systems work satisfactorily as long as there is not a great amount of noise interference and not too much variation in amplitude between pulses coming from stations of different strength. Even in the face of considerable interference and signal variation, the vertical or field sweep can usually be made to lock satisfactorily with a trigger system, because the low-frequency vertical oscillator is relatively stable, and the kind of pulse that is used for controlling the vertical oscillators is of such shape that minor interferences are not too troublesome.

The horizontal sweep is much more susceptible to variations in the controlling pulse, because loss of synchronization for even one line produces a “tearing” across the picture. Therefore, in many receivers you will find that the horizontal sweep oscillator is fed control pulses through a locking or automatic frequency control arrangement of such a nature that the average sync pulse spacing over several lines is used in a comparison sys-

tem to lock the horizontal oscillator to the proper frequency.

In this Lesson, we are going to learn all about the clipping and segregating of pulses, sync amplifiers, and the special locking circuits that are used to control horizontal sweep oscillators. However, before we get into these subjects, let's learn something more about the operation of an R-C charging circuit. This rather simple network shows up in several different forms in the sync control chain.

R-C RESPONSES

The simple R-C network shown in Fig. 1 is used in a great number of ways in television because of the amazing variety of responses this circuit has to waves of different shapes. We have shown two circuits in this figure. As far as a.c. is concerned, their actions are the same. In most cases, the circuit in Fig. 1A (in which the lower end of the resistor is grounded) is used; sometimes, however, it is necessary to ground the condenser, in which case the circuit in Fig. 1B is used. You may, therefore, find either arrangement in television circuits. Just remember that the response of each is the same.

When the input voltage e applied to the circuit in Fig. 1A is a *sine wave*, the only effects produced on the voltage are that it is divided and is shifted in phase. That is, as the frequency decreases, more voltage appears across the condenser and less across the resistance, and the resistance drop gets more out of phase with respect to the source voltage. However, the wave shape is still that of a sine wave. It is important for you to remember this fact—the response of this network to a *sine-wave* voltage is that a sine-wave voltage appears across each of the parts. The relative amplitudes of these voltages depend on the ratio of the reactance to the resistance. When we apply a voltage

that is not a sine wave, however, the response of this circuit becomes very different.

Square-Wave Response. Let us briefly review the response of a circuit of this sort to the kind of wave shapes used in the sweep chain. You will recall that if a d.c. voltage is applied suddenly by turning on a switch, the condenser will charge up at a rate determined by the time constant of the R-C parts. Therefore, when a d.c. voltage is applied suddenly as in Fig. 2A, there will be at first a rush of current to charge the condenser. This current flow is limited by the series resistor R. Initially, the condenser will have no voltage across it, but the charge will build up until eventually the condenser voltage equals the voltage of the source. Thus, the condenser voltage curve is somewhat like curve 1 in Fig. 2B.

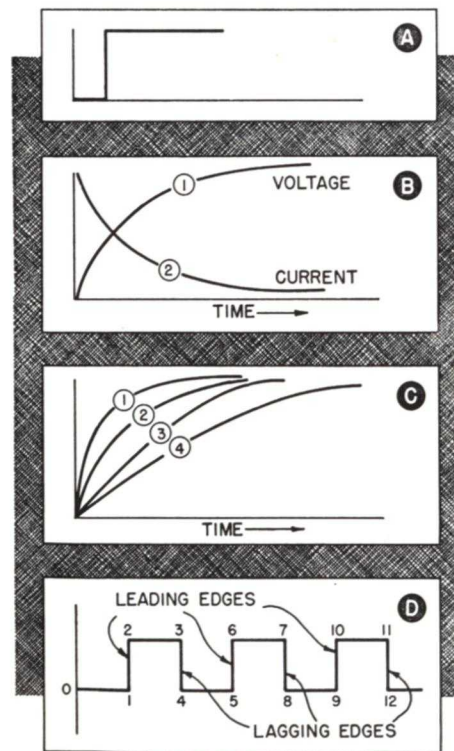

FIG. 2. Response of an R-C circuit.

The current through the circuit (curve 2) goes down as the condenser voltage goes up. The voltage drop across the resistor is in phase with the current flow through the circuit, so that curve 2 can also represent the voltage across the resistor. Thus, the resistor voltage is maximum and the condenser voltage is minimum when the circuit is first turned on; the condenser voltage then goes up, whereas the resistor voltage goes down.

Since the rate at which the condenser charges depends on both the size of resistor R and the size of the condenser, the charging curve changes in shape if different part values are used. For example, if either the condenser or the resistor (or both) is made larger, it will take longer for the condenser to charge, so the charging curve will be flatter. Fig. 2C shows curves for the condenser charging action in circuits having different time constants. Curve 1 is the curve for the circuit having the shortest time constant, curve 4 that for the circuit having the longest time constant. From these curves, you can see that the voltage across the condenser at a particular time depends on the time constant of the circuit: shortly after the switch is closed, the voltage can be high if the circuit has a short time constant but fairly low if the time constant is long. After a while, of course, the condenser in either kind of circuit will charge to approximately the source voltage.

If the applied voltage is turned off and the circuit is short-circuited, it will discharge along a curve much like the charging curve except that it will be inverted. If we apply power and turn it on and off regularly, or apply a square-wave a.c. signal, we will get a charging action that begins at the start of each pulse and a discharging action that starts at the end of each

pulse. Thus, if we have the pulses 1-4, 5-8, and 9-12 shown in Fig. 2D, the condenser will start to charge when the "leading" edge of each pulse (the change 1-2, 5-6, or 9-10) occurs, and will start to discharge in step with the "lagging" edges (3-4, 7-8, or 11-12).

Fig. 3 shows the action for different time constants. Notice how the voltages across the condenser and resistor depend on the time constant of the circuit.

If the time constant is long, the condenser can charge but slowly. Hence, the resistance voltage rises to a maximum in step with the leading edge of

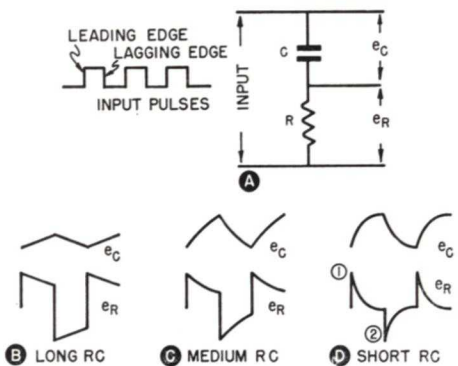

FIG. 3. Variations in output voltages produced by changing the time constant of an R-C network.

the square wave, then drops off gradually. At the lagging edge, the current flow reverses its direction, and since the condenser voltage adds to the supply voltage on each alternation, the resistor voltage changes sharply to the opposite polarity. Therefore, when the time constant is long, the voltage across the condenser and that across the resistor have the shapes shown in Fig. 3B. During the time the pulse is applied, the voltage across the resistor will remain at a high value because there is current flow through it all the time until the condenser is fully charged. Since the

condenser is charging very slowly, there is practically a constant voltage across the resistor during the charging time.

If the circuit has a medium time constant, the condenser charges more rapidly, and the voltage across the resistor drops more rapidly. The curves for such a circuit are shown in Fig. 3C.

If the time constant is very short, the voltage curves are like those shown in Fig. 3D. Notice particularly the resistor voltage. Effectively, what we get is a very high, sharp pulse (point 1) in step with the leading edge of the applied square-wave voltage, and another similar pulse (point 2) at the time of the lagging edge of the square-wave voltage.

This ability to produce a very sharp pulse in synchronism with the leading and lagging edges of the applied pulse is quite important, as we shall show later.

Incidentally, the low-frequency components of the signal appear across the condenser because the condenser reactance becomes higher at these frequencies. Therefore, the resistor voltage represents the high-frequency elements in the applied signal. If this network is arranged so that the desired output is taken from across the resistor, it is known as a "differentiating" network, whereas if the output is taken from across the condenser, it is called an "integrating" network. These terms will be met again later in this text.

Special Wave Shapes. There are occasions in the circuits we are going to study in which more than one of these R-C networks may be used in cascade. In particular, you may find two or more integrating circuits used after one another to get a wave of some particular shape.

For example, Fig. 4A shows a kind of pulse that is applied to an inte-

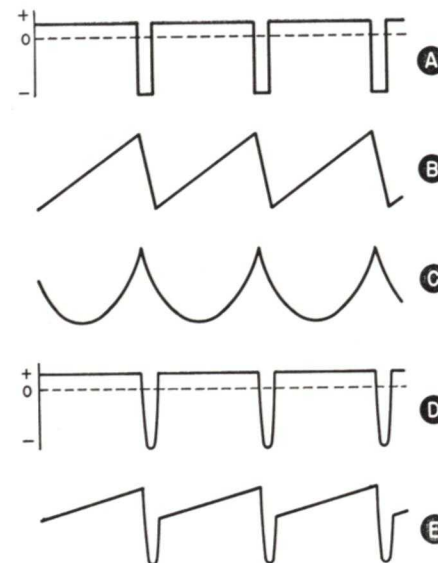

FIG. 4. Responses of integrating circuits to various wave forms.

grating circuit in one part of a TV set. The very high swings in the negative direction are sufficient to force the discharge of the circuit; as a result, the voltage across the condenser has the saw-tooth form shown in Fig. 4B. Then, this saw-tooth voltage can be fed into another integrating circuit from which we will get the parabolic curves shown in Fig. 4C.

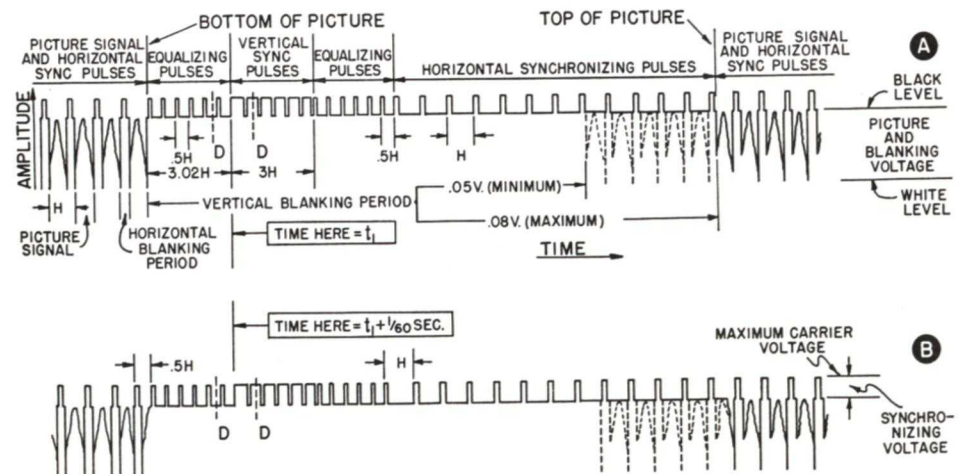

FIG. 5. The voltage forms that make up a complete television signal.

It is important when we consider the operation of a circuit like this to realize that the pulses shown in Fig. 4A are actually squared pulses. For example, the wave form in Fig. 4D looks very much like that in Fig. 4A until you realize that the pulses in D are really halves of sine waves. Since a sine wave comes through an integrating circuit unchanged, the result of feeding pulses like those in D to an R-C circuit is much as is shown in Fig. 4E. Here, integration occurs during the flat portions of the wave, but the "dip" in the wave E looks exactly like the sine-wave portion of the original signal in D.

Naturally, the exact wave shape produced by an R-C circuit will depend upon whether it has a short, medium, or long time constant, and hence there are very many different possible shapes that are obtainable.

STANDARD TV SIGNAL

The various signals that are sent out by the transmitter in the region of the vertical blanking during the scan of one frame (two fields) are shown in Fig. 5. Among these is the picture signal for each line, at the end of which there is a blanking pedestal.

This blanking pedestal represents a voltage that is capable of cutting off the electron beam when it is applied to the picture tube; therefore, the pedestal represents a "black" signal. On this pedestal is the line (horizontal) sync pulse.

The vertical blanking period starts when the bottom of the picture is reached. It exists for the time that it takes to scan about nineteen or twenty lines. At a time approximately three lines from the beginning of the vertical blanking period, the vertical sync pulse begins. It lasts for a time duration of three lines. It is followed by horizontal synchronizing pulses during the vertical blanking period in which the vertical retrace carries the beam back up to the top of the picture. At the top of the picture, several lines are blanked out; during this time, the circuit settles down and prepares for the actual visible portion of the picture.

You can see from Fig. 5 that the horizontal and the vertical sync pulses are on blanking pedestals; therefore, they extend above even the signal levels that represent a black picture,

and, as a result, cannot produce a visible picture on the face of the picture tube. A further examination of the sync pulses will show that the sections of the vertical pulse are quite broad compared to the horizontal sync pulses.

Pulses of a third kind—the equalizing pulses—also exist in the transmitted signal. These are even narrower than the horizontal sync pulses and occur at half-line intervals rather than at one-line intervals. These equalizing pulses, as we shall show elsewhere, are needed so that we can maintain horizontal sync during the otherwise solid vertical sync pulse. Therefore, we have three different kinds of pulses, all of the same amplitude but of quite different widths, in the transmitted signal. All these pulses are capable of being separated from the signal by an amplitude clipper, because each of them is above the level of the highest signal voltage. Let's go on to see how this is done.

Sync Clippers

The job of separating all the sync pulses from the picture information is made easier by the fact that the former are all above and the latter are all below the level of the blanking pedestals. If we feed a signal like that shown in Fig. 6A into a properly designed clipping circuit, it can cut off the picture information from the sync pulses, producing an output like that shown in Fig. 6B. All pulses above the pedestal level can be removed in

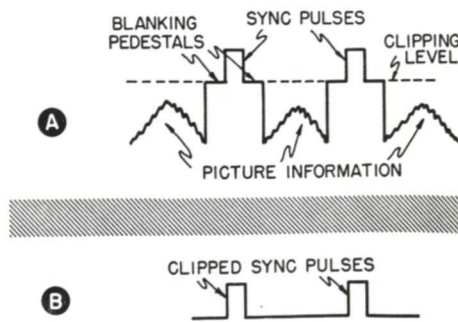

FIG. 6. How sync pulses are clipped.

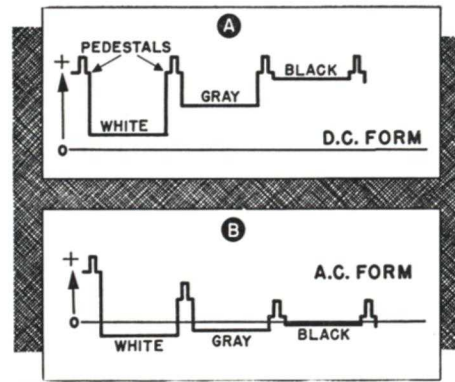

FIG. 7. The d.c. and a.c. forms of a TV signal.

this way—it does not matter to the clipper circuit whether they are horizontal sync, vertical sync, or equalizing pulses.

It is possible to use diode, triode, or pentode tubes in clipper circuits. Before we study the many different kinds of clippers, let us learn a little more about what the requirements for clipping are.

D.C. Level. The first requirement is that the pedestals must be lined up before a television signal can be clipped. That is, we must have the signal in its d.c. form. You will recall that all the pedestals are at the same level, as shown in Fig. 7A, when the signal is in its d.c. form. When it is in the a.c. form, on the other hand, the pedestals are not at the same level. As a simple example, let us suppose that we are using a clipper stage that has an operating curve like that shown in Fig. 8. When the signal is in the d.c. form shown in Fig. 8A, and the pedestals are lined up with the cut-off bias value, the plate current will contain only the sync pulses (Fig. 8B). On the other hand, if we apply the signal in its a.c. form (Fig. 8C), the output will have the form shown in Fig. 8D. In this case, if we set the bias so that the pedestals for a gray line match up with the cut-off value,

we will get the pulses from this line. However, the black line pulses will be rejected completely, and part of the video signal will pass along with the white line sync pulses.

From the foregoing, you can see that we can get clipping quite easily by lining up the pedestals with the cut-off point of a tube as long as we have a d.c. signal form. Therefore, as a requirement for clipping, either the clipper must be d.c. coupled to some point in the video amplifier where the signal exists in a d.c. form, or we must introduce restoration to get it back to this form at the input of the clipper.

BASIC DIODE CLIPPER

Fig. 9 shows a basic diode clipper circuit. As you will recall, it is possible for a television picture to have either a negative or a positive picture phase at the output of the video detector or in the video amplifier.

Let us suppose first that we have the negative picture phase shown in

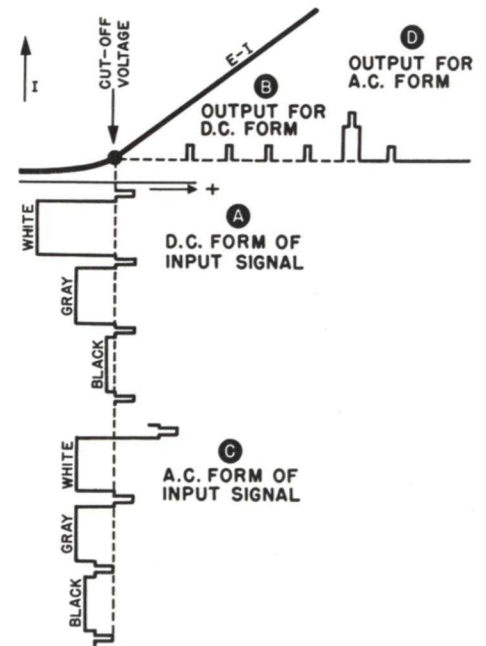

FIG. 8. Why a d.c. signal form must be used for clipping.

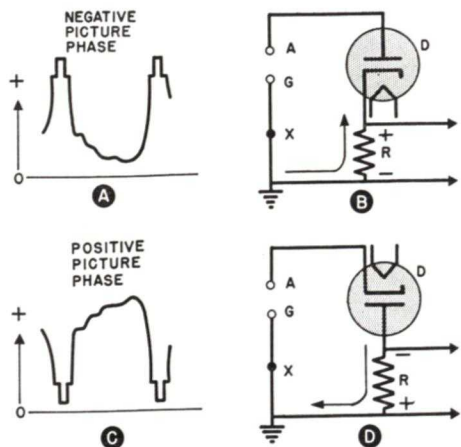

FIG. 9. Basic diode clipper circuits.

Fig. 9A. (The whiter the scene, the more negative the voltage in this case.) If we apply this to the diode circuit shown in Fig. 9B, we will get an exact replica of the signal across the load resistor R. In this case, clipping has not occurred. However, if we introduce a bias at point X of such a polarity that point G is made negative with respect to ground, the picture signal must overcome this bias before any current can flow through the diode tube. Hence, if we arrange this bias so that only the sync pulses can make the diode plate positive and cause current flow, we can secure the form of clipping that was shown in Fig. 8. Of course, we must start with a signal in which the pedestals are lined up.

If the signal has a positive picture phase (Fig. 8C), we must invert the diode as shown in Fig. 8D. With this arrangement, terminal G will always be negative with respect to A when a signal is applied, so no current will flow. However, the pulses are in such a direction that the terminal G will become less negative during the sync pulses. Therefore, we must introduce a bias voltage at point X of such a polarity that point G will be made negative with respect to ground. If

this bias voltage is properly adjusted, the sync pulses will drive the plate of the diode sufficiently positive with respect to the cathode for current to flow, but the rest of the signal will overcome the bias and cut off current flow.

With these diode circuits, the output pulses will have the polarities indicated across the load resistor R in either B or D in Fig. 9. In both instances, we need to apply a bias voltage to the diode so that it will conduct only on the sync pulses. Of course, this bias voltage need not come from a separate source—it is possible to obtain it as a result of signal rectification in the diode itself. A more typical diode circuit arrangement in which self-bias is used is shown in Fig. 10.

With the arrangement shown here, the tube VT_1 acts as a clipper and is independent of the video detector and video amplifier. It gets its signal from the i.f. transformer L_1 , which is tuned by condenser C_1 . This signal is applied to the video detector and also to the clipper VT_1 . On the positive pulses of the signal, rectification takes place in the clipper tube, and con-

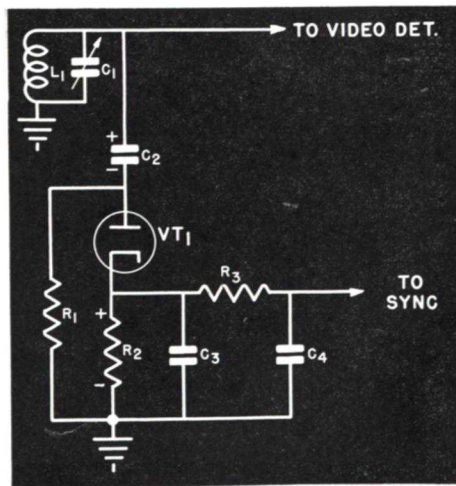

FIG. 10. Practical self-biased diode clipper.

denser C_2 becomes charged with the polarity shown. It cannot discharge rapidly through the high resistance R_1 , so its voltage becomes an average bias value that follows the signal levels. Hence, we have effectively a form of d.c. restoration that lines up the pulses. At the same time, this bias voltage is of such value that only the sync pulses can overcome it and cause current flow through resistor R_2 .

Here, condensers C_3 and C_4 and resistor R_3 act as a low-pass filter to remove any r.f. that appears across R_2 ; thus, the output of the clipper contains only the sync pulses. These pulses may be fed to either a sync amplifier or a segregation network. If the polarity of the pulses is wrong for the sweep oscillator, either an amplifier must be used to invert the polarity, or tube VT_1 must be inverted so as to obtain pulses having the opposite polarity.

Since the clipper tube VT_1 can act as its own d.c. restorer, we are now free to connect it to any point we wish in the video amplifier, whether the pedestals are lined up at that point or not. This allows us to take advantage of the extra gain of the video stages. It is becoming common practice to take the sync pulses from the output of the video amplifier. However, it is possible to take these pulses from another stage if polarity is a problem.

It is even possible to d.c. couple, as shown in Fig. 11, to some point where the video signal exists. Here, the signal exists across R_1 , which may be a grid resistor or even a load resistor in the video circuit. Tube VT_1 is arranged in a network such that the bias developed by R_2 and C_1 will either act as a bias to provide clipping (if the signal across R_1 is in the d.c. form) or act as a restorer if the signal across R_1 is in the a.c. form. The sync pulses are produced across the resistor R_3 .

Although the diode clipper is perfectly satisfactory as a means of separating the picture signal from the synchronizing pulses, it does not amplify; also, it tends to load the source, thus affecting the frequency response of the video amplifier. Clipper circuits in which triodes and pentodes are used have been developed that do not have these disadvantages. Let us see how they work.

TRIODE CLIPPER

A simple triode clipper is shown in Fig. 12B. When the signal shown in Fig. 12A is applied to this circuit, grid current will flow, charging condenser

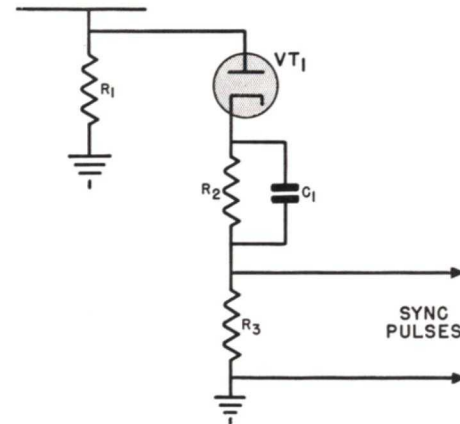

FIG. 11. D.C. coupling to a diode clipper.

C_1 . If the proper values are used for C_1 and R_1 , this charge will reach such a point that all of the signal below the clipping level will be beyond cut-off, and only the sync pulses will drive the tube into the conducting region. The amplification of the tube will cause the output pulses developed across R_2 to be larger than the original sync pulses. Since it is quite desirable to have large pulses, circuits of this sort are frequently used in TV sets.

Of course, such a tube inverts the phase of the pulses 180° . If the input pulses are going in the positive direc-

tion as shown in Fig. 12A, they will be going in the negative direction across R_2 . Pulses of this polarity can be used to operate a multivibrator oscillator but not a blocking oscillator; if the latter is used in the sweep circuits, therefore, it will be necessary to invert the phase of the sync pulses.

Such phase inversion may be obtained by following this clipper stage with an amplifier or by inverting the phase of the signal at the input to the clipper. If the latter method is used, some changes must be made in the circuit. That is, if a signal of the kind shown in Fig. 12C is applied, the circuit must be modified as shown in Fig. 12D, and the tube must be made to operate at the plate current saturation point at the upper knee of its characteristic curve. When this operation is used, signal swings will drive the grid more positive, but no more plate current can flow. On the other hand, the sync pulses will decrease the

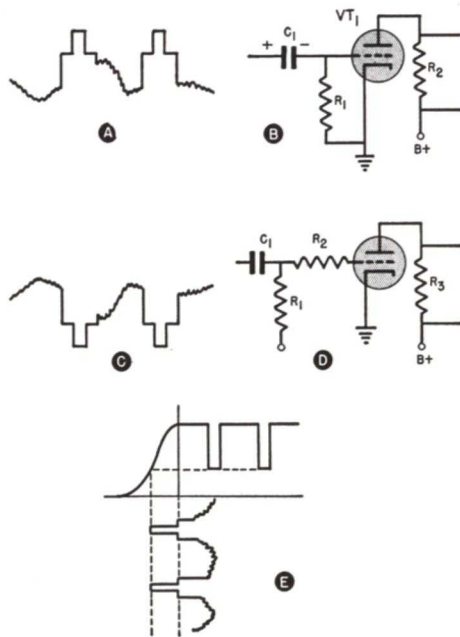

FIG. 12. Two triode clipper circuit arrangements.

grid voltage and thus reduce the plate current.

The operation of this circuit over the upper knee of the characteristic curve is shown in Fig. 12E. The bias applied through resistor R_1 from a separate source must hold the tube grid near zero bias or even slightly positive to produce this operation. In

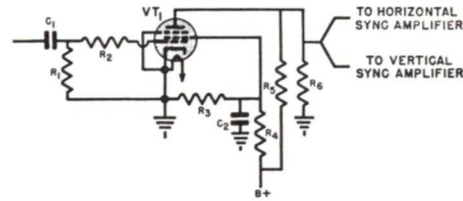

FIG. 13. Typical pentode clipper circuit.

addition, the plate voltage in this stage is made low so that saturation occurs near zero bias.

Resistor R_2 is added to the circuit shown in Fig. 12D so that if the tube should draw an abnormally high grid current, as it may when a strong noise pulse comes through, the circuit will not be blocked and rendered inoperative.

The output pulse is of course opposite in polarity to the plate current change—a drop in the plate current causes a rise in the plate voltage, with the result that the sync pulses are positive at the output of this circuit.

PENTODE CLIPPER

The pentode tube lends itself very well to use as a clipper. A typical circuit arrangement is shown in Fig. 13. The initial bias that produces tube cut-off is obtained by grid rectification—condenser C_1 charges when the grid goes positive and then must discharge through the relatively high resistance R_1 . Therefore, the basic clipping action of this circuit is much like that of those we have already described.

However, we can get another action from the pentode circuit by reducing

the plate and screen grid voltages to very low values. The voltage division produced by resistors R_5 and R_6 in the circuit in Fig. 13 is such that the plate voltage is quite low—it may be only about 5 to 10 volts. The screen grid voltage, which is determined by the voltage division between R_3 and R_4 , is also low.

With both these voltages very low, the circuit will saturate quite easily, producing the action shown in Fig. 14. Once the initial clipping bias has been set up, the picture signal (which swings below the cut-off point) will cause no plate current. The sync pulses will cause plate current, but, because of the upper saturation bend of the characteristic, there is a limit to the amount of plate current they can cause. If the sync pulses are higher than the saturation level, they will be cut off as shown here. Therefore, the circuit can take sync pulses of different amplitudes and produce pulses of constant amplitude from them. Hence, noise pulses and increases in the signal strength that might change the amplitude of the sync pulses will all be wiped out by this circuit. This feature makes the pentode clipper rather popular. With other clippers that do not have this limiting feature, you will generally

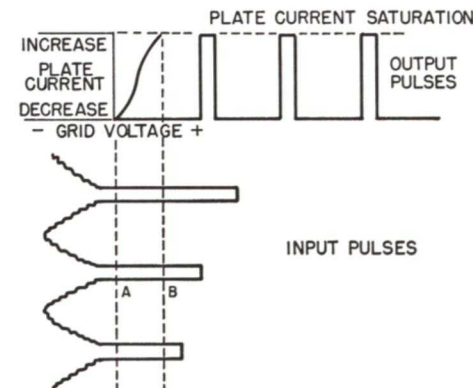

FIG. 14. Limiting action of a pentode clipper.

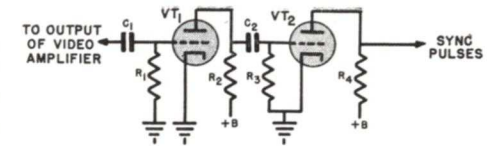

FIG. 15. A double clipper circuit.

find that one or more of the associated amplifiers (we are going to study these) will be arranged to provide a limiting action like the one that is obtained in the pentode stage.

Resistor R_2 is added in the circuit of the pentode clipper in Fig. 13 so that strong noise pulses will not cause excessive grid currents and thus develop a blocking bias.

DOUBLE CLIPPER

The same clipping plus amplitude limiting that is obtainable with a pentode can be obtained with two triodes used in the circuit shown in Fig. 15. These two triodes can be in the same envelope in the form of a dual triode.

Initially, the basic clipping occurs in the grid circuit of VT_1 , where the grid current flow charges condenser C_1 .

The pulses existing across R_2 are therefore separated by VT_1 from the video signal, but the pulses may be of unequal amplitudes. However, VT_1 has inverted the phase, so that the pulses are now swinging in the negative direction. When these pulses are applied to tube VT_2 , the pulses above a certain amplitude will be beyond cut-off, so amplitude limiting (or second clipping) occurs. VT_2 inverts the phase again, so that the output pulses across R_4 now swing in the positive direction.

Notice that the grid circuit of VT_2 does not provide a bias to follow the pulses. Such a bias is unnecessary because the pulses swing negative. This is fortunate, because it makes it

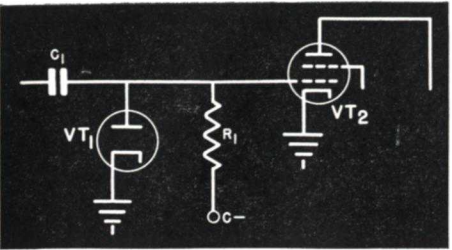

FIG. 16. Sync-clamper circuit.

possible to use a low resistance as grid resistor R_3 ; it is necessary to use a low resistance here to provide wide band response so that the sync pulses can get through without distortion.

Sync Clamper. Although it is possible to produce d.c. restoration in the clipper circuit quite simply by grid rectification, it is sometimes undesirable to do so, particularly when we

want the clipper to act reasonably well as an amplifier. In such cases, often a fixed bias is applied to the clipper; a separate diode rectifier is then used for d.c. restoration. A typical circuit is shown in Fig. 16. The diode rectifier VT_1 acts in conjunction with C_1 and R_1 as a d.c. restorer just like those used in the video amplifier. The restored signal across R_1 is fed to the clipper tube VT_2 . This tube is so biased that the pedestals line up at the cut-off point, and plate current will flow only on the swings of the sync pulses into the less negative grid region.

Although tube VT_1 acts exactly like any other d.c. restorer, it is given the name of "clamper" to distinguish between it and the true d.c. restorer that operates on the picture signal.

Sync Amplifiers and Segregating Circuits

As we have pointed out, it is possible to obtain the desired signal for the clipper (the picture signal plus the sync pulses) anywhere in the video amplifier, from the second detector to the grid of the picture tube. Whether or not the signal is in its d.c. form at the point from which it is taken is not particularly important; as we have shown, it is always possible to produce d.c. restoration in the clipper circuit if necessary. Of more importance are the phase of the signal and the level of the sync pulses.

The picture phase on which the clipper is designed to operate restricts the number of points from which the signal can be taken. Obviously, if the clipper requires positive pulses, we must take the signal from some point

in the video amplifier where the pulses are swinging in the positive direction, and conversely for a clipper that requires negative pulses.

The strength of the sync pulses (and consequently the definiteness of the control action) depends upon the point in the video amplifier from which the signal is taken, increasing as the point is moved farther along. Therefore, there is a growing tendency to get the signal for the clipper from near the output of the video amplifier. In most modern receivers, in fact, you will find that the sync pulses are obtained either from the plate circuit of the output video stage or from its grid circuit, depending upon the point at which the signal phase is proper for the clipper circuit.

Many manufacturers do not feel that even the signal from the video amplifier is strong enough for best clipping. For this reason, they very frequently include an amplifying stage ahead of the clipper. This amplifier may be either a triode or a pentode tube. When such an additional amplifying stage is used, the fact that it inverts the picture phase 180° must be taken into consideration so that the clipper itself will be fed with signals having the proper phase.

It is also common practice to include amplifiers following the clipper. There may even be amplifiers following the point at which the synchronizing signals are segregated—an amplifier for the vertical pulses being entirely separate from one that is used for the horizontal sync pulses.

As a matter of fact, the double clipper shown in Fig. 15 acts as a double amplifier. It is possible to set the bias so that the second tube will serve only as an amplifier rather than as a second clipper (amplitude limiter). Usually, however, the circuit is arranged so that the amplifier gives the second clipping and thus removes noise pulses that might drive the sync pulses to amplitudes that would be higher than normal.

Fig. 17 shows a typical chain consisting of an amplifier, a clipper, and a second amplifier. In this circuit,

tube VT_1 is biased for normal operation as an amplifier. In this example, instead of using self-bias, the grid bias is obtained from a voltage divider arrangement that operates from taps on the power supply. This voltage divider is adjusted so that the proper operating bias is obtained. Manufacturers use arrangements like this rather than furnish additional taps on the voltage divider in the power supply.

The sync pulses obtained from the video output in this instance are in the negative direction. Tube VT_1 amplifies both the pulses and the signal components. However, the arrangement is such that if any sync pulses are driven very far negative by noise pulses, they will be beyond the tube cut-off point. This tube therefore provides an initial clipping of the amplitude of the pulses.

Since VT_1 inverts the phase of the pulses, it feeds positive pulses into tube VT_2 . The operating voltages applied to this tube are such that the picture signal is cut off at the pedestal level because all the picture signal is below the cut-off level set for the tube. D.C. restoration occurs in the grid circuit of this tube to align the pedestal levels.

At the output of VT_2 , the pulses are again negative. If positive pulses are needed—for application to the grid of

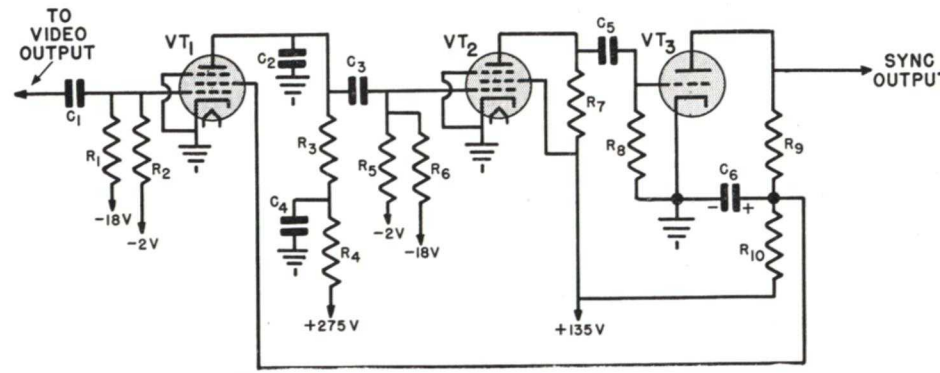

FIG. 17. Typical sync amplifier-clipper chain.

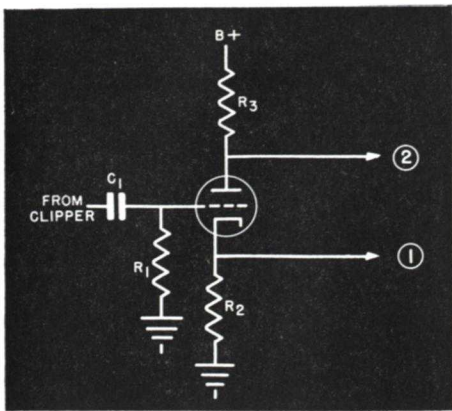

FIG. 18. Circuit furnishing positive and negative pulses.

a blocking oscillator, for example—an additional amplifying tube VT_3 is used to increase the strength of the pulses again and to invert their phase to give an output of the proper polarity. At the same time, any pulses that swing too far negative will be clipped again by VT_3 ; at its output, therefore, the pulses are restricted and are practically all of the same amplitude. This removes any increases in the pulse levels caused by noise or other interferences.

Although we have spoken of the “proper” polarity for the pulses, it may be that we want pulses of both polarities after clipping, since one of the sweep chains may use a multi-vibrator and the other a blocking oscillator. Fig. 18 shows a circuit that will furnish pulses of both polarities at the same time. The amplified pulses across R_2 in the cathode circuit of the tube have the same phase as the signal that comes from the clipper, whereas the phase of the voltage in the plate circuit, across R_3 , is inverted 180° . Thus, if the pulses from the clipper have a positive phase, the output from terminal 1 will also be positive, but that from terminal 2 will be negative.

To sum up, the chain of stages used to extract the sync pulses from the transmitted signal may consist only of a clipper, but it is more usual practice in the receivers of today to have at least one amplifying stage in addition to the clipper and possibly to have as many as three or four amplifiers—one ahead and one after the clipper, plus an additional one either in the horizontal or in the vertical chain, or in both. One or more of these amplifiers may serve as an amplitude limiter (second clipper) as well as perform as a normal amplifier. In addition, you may find a clamper tube used to give d.c. restoration.

SYNC SEGREGATION

The final product at the output of the clipper or at the output of a following amplifying stage consists of three kinds of pulses. We have the line pulses that occur at the end of each line. Then, we have the vertical pulse, which exists for a space occupied by three lines, but which is cut up at half-line intervals so that the horizontal or line synchronization may be maintained during it.

For a space of three lines before the vertical pulse and for another three-line space after the vertical pulse, there exists a series of equalizing pulses. These pulses occur at twice the horizontal or line pulse rate—at half-line intervals, in other words. These equalizing pulses serve to cut up the vertical pulse and to provide line synchronization at the end of each field. You will recall that one field ends in the middle of a line, but the next one ends exactly at the end of a line. Therefore, there is a half-line difference in the two fields, a condition that is necessary for interlaced scanning. Since the equalizing pulses are at half-line intervals, alternate equalizing pulses are used just like



FIG. 19. The line, equalizing, and vertical sync pulses in a TV signal.

the line pulses to control the horizontal sweep chain. One set of equalizing pulses is at the end of one field and the other set at the end of the next, but the action is the same.

The various pulses are shown in Fig. 19. This figure shows the relative widths of the pulses; as you can see, they are different in their widths as well as in their frequencies.

Once the sync signal containing these three kinds of pulses has been separated from the video signal, we must separate the line and equalizing pulses from the vertical pulse so that the horizontal pulses can be applied to the horizontal sweep chain and the vertical pulses can be applied to the vertical sweep chain. To separate these two types of pulses, we use R-C networks.

Horizontal Separation. We can obtain a control pulse that will be timed exactly by the leading edge of the horizontal pulses by using a differentiating network like that in Fig. 20 having a short time constant. Fig. 21 shows what happens when the group of pulses in Fig. 19 is fed to such a network.

In Fig. 21A, we have repeated the group of pulses that we had in Fig. 19. When the pulses are fed into the differentiating network, the output across R_1 will be like that shown in Fig. 21B. Every time there is a sharp change in the voltage caused by either the leading or lagging edge of a pulse, a corresponding sharp pulse will be developed across R_1 . As Fig. 21B shows, these pulses will be caused by the edges of each pulse in the output of the clipper, whether the original

pulse is a horizontal (line) pulse, an equalizing pulse, or the serrations in the vertical pulse.

Notice that the leading edges produce pulses having a polarity that is opposite to that of the pulses produced by the lagging edges. Only the pulses produced by the leading edges (the pulses numbered from 1 to 22 in Fig. 21B) are properly spaced to be usable for horizontal synchronization, because they are spaced so that they are either one-half line or one line apart. The space from pulse 1 to pulse 2 in Fig. 21B, for example, is equal to one line. The same is true of the spacing between pulse 2 and pulse 3. The pulses from 3 to 21 are a half-line apart, because they occur in step either with the equalizing pulses (those from 3 to 8 or from 15 to 21) or with the half-line intervals in the vertical sync pulse (those from 9 to 14).

On the other hand, the pulses produced by the lagging edges in Fig. 21B cannot be used, because they are upset at the beginning and end of the vertical pulse. They are spaced properly from pulse 23 to pulse 24, but the space from pulse 24 to pulse 25 is not equal to either one line or a half line. Then, the space from pulse 26 to pulse 27 is less than a half line.

Of course, since the pulses produced by the leading and lagging edges are

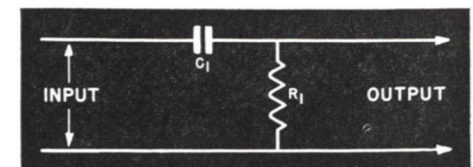

FIG. 20. Typical differentiating network.

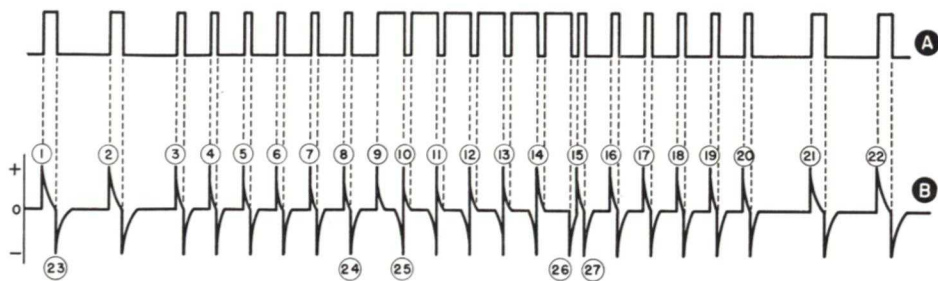

FIG. 21. The pulses in B are produced by feeding those in A into a differentiating network.

opposite in polarity, it is simple to arrange for only those produced by the leading edges to be used. For example, let's assume that the pulses 1 through 22 are all in the positive direction, which makes the other pulses extend in the negative direction. If we apply these pulses to the input of a blocking oscillator, only those moving in the positive direction will be able to set off the circuit. Suppose, for example, that the pulse chain shown in Fig. 22 is applied to the grid of a blocking oscillator. Since the pulses S_1 , S_2 , and S_3 swing in the positive direction, they will force the grid voltage above the cut-off level, so that the blocking oscillator will produce its pulses in step with these synchronizing pulses. Pulses of the opposite polarity (S_4 - S_7 - S_8 - S_9 - S_{10}) will be ignored by the circuit.

We mentioned that there are pulses at half-line intervals during the equalizing and vertical pulse intervals. However, as Fig. 22 shows, half-line pulses S_4 and S_5 , although of the right polarity, are not of sufficient amplitude to drive the blocking oscillator grid voltage above the cut-off level. Hence, these pulses are simply ignored—only those occurring at the right time (that is, near the time when the oscillator would operate by itself) can control the horizontal blocking oscillator.

At the end of every alternate field, however, these half-line pulses take over control of the horizontal oscillator. This occurs because alternate fields end in the middle of a line. During one vertical sweep, therefore, the pulses S_4 and S_5 occur at the wrong times to exert control; during the next field, however, they occur at the right times and trigger the horizontal oscillator.

If the horizontal system uses a multivibrator, we need pulses with a negative polarity if the signal is to be applied to the grid of the first tube. As you saw a moment ago, the negative pulses (Fig. 21B) produced by the trailing edges cannot be used because they are not properly spaced. Hence, either we must invert the clipper so as to produce pulses of the opposite polarity, or we must feed the pulses shown in Fig. 21B through an amplifier stage to invert the phase 180° and therefore make the positive pulses

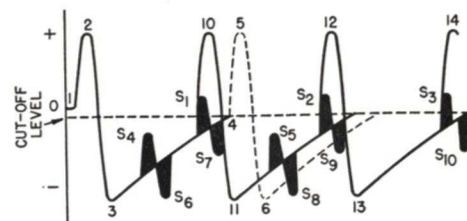

FIG. 22. How alternate positive half-line pulses can control a blocking oscillator.

become negative ones. In this case, we don't want the pulses that go in the wrong direction, so this amplifying stage can act as a clipper, as shown in Fig. 23, to remove the pulses that swing in the wrong direction. If we overdrive this amplifier and use a low plate voltage, the pulses will be reshaped and limited in amplitude and thus be better for use as control

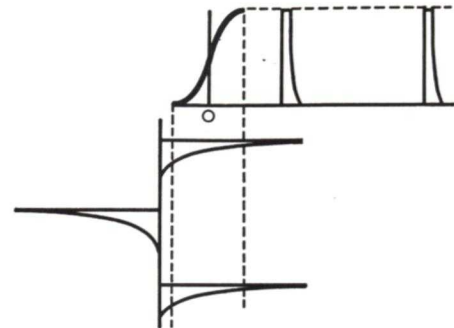

FIG. 23. Using a horizontal sync amplifier as a clipper.

pulses. Since the use of such a circuit makes it necessary to have one more tube, it is more common to arrange the clipper to give pulses of the proper polarity.

Vertical Separation. Now that we have satisfactorily arranged for getting the horizontal pulses, we need to get the vertical control pulse. We can do so by using an integrating circuit like the one shown in Fig. 24 that has a fairly long time constant.

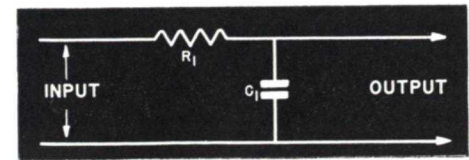

FIG. 24. Typical integrating network.

When the pulses shown in Fig. 25A are fed into this circuit, its output will be like that shown in Fig. 25B. Because of the long time constant, the condenser is charged only slightly during each horizontal line pulse, and somewhat less during each of the narrower equalizing pulses. The voltages produced by these chargings are ignored by the circuit to which the signal is fed, because they are too small in amplitude to affect the circuit.

During the vertical pulse interval, however, there is time for the charge across C_1 to build up to a much higher level. (Since the vertical pulse shown in Fig. 25A is much wider than the horizontal pulses, the vertical pulse is applied to condenser C_1 for a much longer period of time, so the condenser is charged much more by the vertical pulse than it is by the horizontal pulse.) Naturally, C_1 discharges a little during the gaps in this pulse, but since these gaps are of relatively short duration, the long time constant keeps the discharge slight. Therefore, the voltage across C_1 builds up as shown in Fig. 25B from the value at 1 to the peak value at 2 during the vertical sync pulse interval. When the verti-

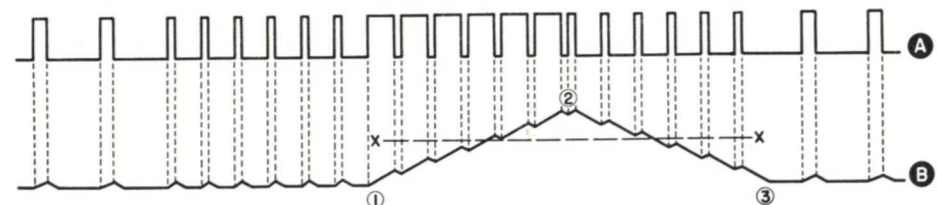

FIG. 25. The long pulse in B is produced by feeding those in A into an integrating network.

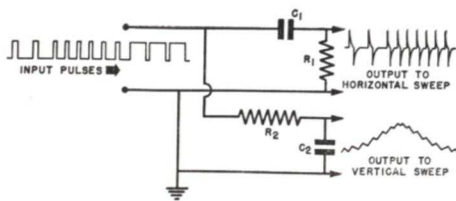

FIG. 26. Sync-segregation circuit.

cal sync pulse stops, the condenser discharges from the value at 2 back to its original value at 3.

From this, by the use of an integrating R-C circuit, we can arrange a gradual charging action on the pulses, and by having a sufficiently long time constant, the horizontal pulses can be ignored (they produce little charge) but the vertical pulse will produce the desired single control pulse.

All we need to do now is to arrange to feed this pulse into a blocking oscillator or a multivibrator and to see to it that this pulse is high enough to initiate the oscillator action. Thus, we can arrange matters so that whenever the voltage across C_1 gets above the value represented by the line X-X, the oscillator will operate and start the retrace.

Generally, both the horizontal differentiating network and the vertical integrating network are connected in parallel, as shown in Fig. 26, to the output of the clipper or of an amplifying stage. Then, when the pulses are fed in, the respective outputs are led off to either the horizontal or the vertical sweep chains.

In some receivers, you will find that a chain of integrating networks, as shown in Fig. 27, will be used to separate the vertical pulse from the other pulses. This double integrating network (or a triple one) serves to smooth out the "teeth" in the pulse that a single integrating network produces. Curve 1 in Fig. 27B represents the output of a single integrating network,

and curve 2 approximates that of the second network. Although the peak value produced by double integration is lower than the one a single network gives, the curve is smoother and therefore produces more precise synchronization. When a single integrating circuit is used, there is a chance that the synchronization may be uneven, because one of the teeth in the curve may happen to fall at a time when the vertical synchronization should occur.

You will notice that there is a difference between the times when the vertical and horizontal circuits "fire." In the case of the horizontal circuits, the synchronizing pulse that is fed to the sweep oscillator occurs exactly in step with the leading edge of the line (horizontal) pulses. On the other hand, the vertical oscillator is not fired until some time late in the vertical pulse interval, the exact time depending upon the R-C time constant. The precise point in the vertical pulse at which the vertical oscillator is set off is not particularly important as long as it is always at the same point in each succeeding frame. If this is accomplished, vertical synchronization will be obtained.

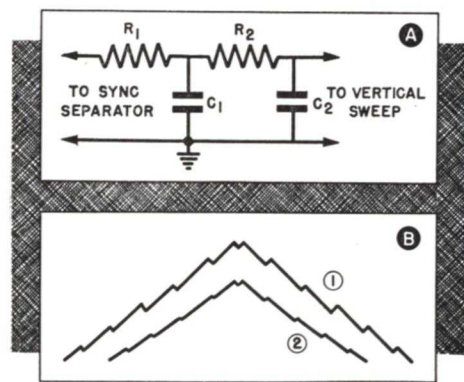

FIG. 27. Effect of double integrating network.

Sync Locking Circuits

In the preceding sections of this Lesson, we have shown how it is possible to separate the sync pulses from the picture signal and to segregate them into vertical and horizontal control pulses. These pulses may be used to trigger the oscillators in the vertical



FIG. 28. Clipping removes amplitude changes.

and horizontal sweep circuits. This method of triggering the sweep circuits is entirely satisfactory for the vertical synchronization; it is also satisfactory for horizontal synchronization provided there is not any great amount of interference being picked up along with the signal.

Even if there is interference, the synchronization is not greatly affected as long as only the amplitudes of the pulses are changed by the interference. The use of double-clipping or clipper-amplifier combinations that square off the pulses in both directions will prevent any amplitude changes in the pulses from being passed on. Thus, if we feed the pulses shown in Fig. 28 through such an arrangement, the pulses will be cut off along the dotted line marked "clipping level." Should any interference or noise signal come along as is shown on pulses C, E, and F, it will automatically be clipped off. As a matter of fact, even the normal pulses A, B, D, and G will thus be reduced somewhat in height.

However, noise and interference pulses can also change the pulse widths. This doesn't matter much as far as the vertical pulse is concerned, because it is already so wide that it

would take a very long burst of interference to increase its width much, and if the interference is that steady, the picture probably will not be very good anyway. Therefore, the vertical sync system will ordinarily hold, even on an interference that changes pulse widths.

This is not true of the horizontal sweep, however. Should any interference broaden the pulse in such a way as to change the time of the leading edge of the pulse, the horizontal sync will be thrown out for that line.

Fig. 29 shows what may happen. The normal pulse A is clipped in amplitude and is otherwise not affected.

The noise interference on pulse B has changed its amplitude, but the change does not matter because it will be removed by the clipper action. It has also widened the pulse so as to move the trailing edge: the pulse should end along the line 4, but it has been widened so that it extends out to position 5. This broadening of the

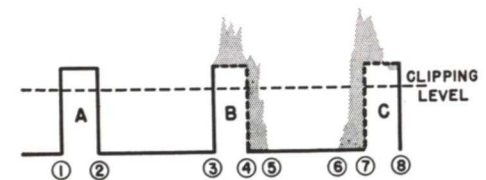

FIG. 29. Clipping does not remove width changes.

pulse is also unimportant, because the trailing edge is not used for synchronization.

However, the interference on pulse C has affected the leading edge. The pulse should start at 7, but actually starts at point 6. Therefore, the spacing from leading edge 3 to leading edge 6 is not correct for a line, so the circuit is kicked off too soon. This puts

one line out of position and results in a tear across the picture. If several lines are affected this way, the picture will be torn up to a considerable degree; if they happen to be consecutive lines, it may well be that the horizontal oscillator will get out of synchronization altogether, making it necessary to readjust the hold control to bring the set back into sync.

Therefore, if there is any appreciable local interference or noise, it may well be that the horizontal oscillator cannot be properly operated from the simple trigger system we have described so far. Remember, this system will work where there is freedom from such interference, so it is still quite widely used. However, a more complicated system is necessary if the set is to work properly in areas where the interference level is fairly high.

There are, in common use, three basic locking circuits designed to solve this interference problem. They all operate on the principle that it is possible for the horizontal oscillator to operate by itself and stay in sync for at least a few lines before it drifts off synchronization. Each system is then designed so that the *average* of the pulses for several lines controls the oscillator; as a result, any abnormal individual pulses are ignored.

Each of these locking arrangements makes use of some form of comparator circuit in which the output of the oscillator is compared with the sync pulses. The difference (if any) between the two is used as a control voltage that ultimately causes the frequency of the horizontal oscillator to shift to the proper value. First, however, this control voltage is applied to filter circuits that tend to cause it to follow the average of the difference between the sync and oscillator pulses. Therefore, if the difference between them is only momentary (caused by a disturbance that lasts for only a line

or two), there will be practically no average difference between them, and the oscillator frequency will therefore not be affected.

HORIZONTAL A.F.C.

One of the most popular means of controlling the horizontal oscillator is through the use of a standard automatic frequency control (a.f.c.) network like that shown in Fig. 30.

Here, tube VT_3 is the horizontal sweep oscillator. This is a sine-wave oscillator in a relatively stable Hartley circuit. The tank circuit consists of coil L_1 plus the distributed and other shunting capacities. This oscillator is designed to operate at exactly the line frequency of 15,750 cycles.

Shunted across the sweep oscillator tuned circuit is a reactance tube VT_4 . You will recall that in a.f.c. systems, the reactance tube is made to draw a plate current that either leads or lags its plate voltage by 90° . Thus, the tube can be made to act either as a capacity or as an inductance, whichever is needed. The amount of reactance simulated by the tube depends on the amount of its plate current. Therefore, the frequency produced by the sweep oscillator depends on how much current the reactance tube is drawing at any particular moment. This current can be controlled by varying the bias on VT_4 ; in fact, this is the method of control used in the a.f.c. system.

To get this control voltage, a standard discriminator circuit using diodes VT_1 and VT_2 is employed. The differentiated horizontal sync pulses are fed from the sync amplifier through C_1 and developed across R_3 ; they are thus applied through the coil L_2 to both diodes simultaneously. Coil L_2 is coupled to the oscillator inductance L_1 . A resonant circuit, tuned to the sweep oscillator frequency, is formed by C_2 and variable inductance L_2 .

The voltages at the two ends of coil L_2 are 180° out of phase—as one end of coil L_2 is going positive, the opposite end is going negative. Also, as you will recall from your study of discriminators, these voltages are mutually 90° out of phase with the voltage that is applied through the coil center tap to both the diodes.

In this arrangement, the sync pulses across R_3 are applied to the diodes in series with the sine-wave voltage across L_2 . Thus, we have the voltages shown in Fig. 31 on the plates of the diodes. When the sweep oscillator is operating at the proper frequency, the phases are such that the pulses occur just as the sine waves go through zero. Therefore, the voltage E_1 applied to one diode is exactly equal to the voltage E_2 applied to the other (since both these voltages at this instant represent only the pulse voltages, which are always equal). Hence, the diodes will pass equal currents through their load resistors (R_1 for VT_1 and R_2 for

VT_2); and since these are equal resistors, the voltage drops across them will therefore be equal. Since the current flow is in opposite directions through the two resistors, their drops will exactly cancel.

The bias applied to tube VT_4 comes through these resistors to the grid of this tube. Therefore, when the phase relationship is that shown in Fig. 31A, the only bias on tube VT_4 is made up of the fixed bias coming from the power supply plus the small additional bias drop across R_3 in its cathode circuit.

Let us suppose now that the frequency of the sweep oscillator changes slightly so that it is lower than the correct frequency. The incoming sync pulses continue to occur at exactly the same time, but the sine-wave voltage now lags behind. As a result, the pulses no longer occur just as the sine-wave voltages go through zero (Fig. 31B); and the voltages E_1 and E_2 therefore consist of the algebraic sum

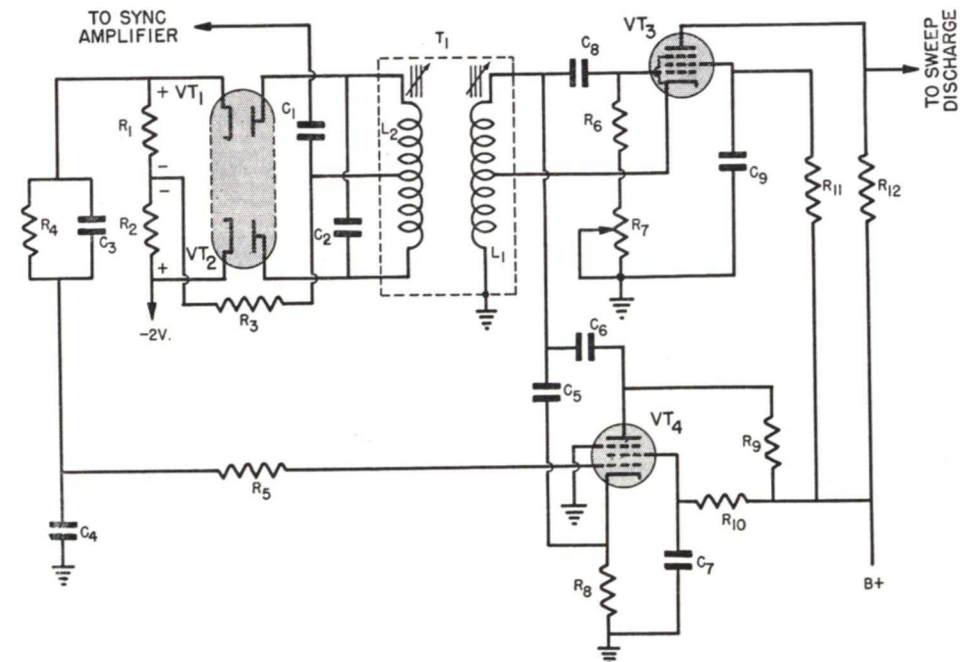

FIG. 30. Horizontal oscillator controlled by an a.f.c. network.

of a sine-wave voltage and a pulse voltage. In this case, E_1 consists of the pulse voltage plus the sine-wave voltage, and E_2 consists of the pulse voltage minus the sine-wave voltage (since this latter sine-wave voltage is going through the negative part of its cycle at this instant). Voltage E_1 is therefore larger than voltage E_2 .

Since the voltages applied to the two diodes are no longer equal, the currents through their respective load resistors are also no longer equal. If E_1 is applied to diode VT_1 , the drop across R_1 will be greater than that across R_2 , with the result that there will be a net voltage across the series combination of R_1 and R_2 having the polarity of the drop across R_1 . Therefore, a positive voltage will be added to the bias of VT_4 , causing this tube to draw more plate current. This circuit is arranged so that tube VT_4 acts as an inductance (the plate current lags behind the a.c. plate voltage). The addition of a positive voltage to its bias will make it act as a smaller inductance in parallel with L_1 , thereby raising the frequency of the sweep oscillator and causing the sine-wave signal to speed up so that the pulse will return to its proper position shown in Fig. 31A.

Conversely, if the local oscillator operates at a higher frequency than it should, E_1 will be a lower voltage than E_2 , as shown in Fig. 31C. As a result, the net additional bias applied to VT_4 , which will be the difference between the two drops across R_1 and R_2 , will have the polarity of the voltage across R_2 . This added bias will increase the negative bias on VT_4 , thereby reducing its plate current, making it act like a higher inductance, and therefore shifting the oscillator to a lower frequency.

Thus, if the frequency of the horizontal oscillator becomes higher or lower than that of the incoming sync

pulses, the action of the circuit is to bring the oscillator back to the correct frequency. This is accomplished automatically.

The circuit is insensitive to pulse amplitude changes because the same pulse is applied to both diodes, and should its amplitude change, both voltages would change to the same degree. If the pulse width should be changed by noise, however, the pulses may effectively occur either sooner or later than they should, causing a shift in the frequency of the sweep oscillator. That is, such a change could occur if the control action were instantaneous. However, the control is not exerted instantaneously; instead, the

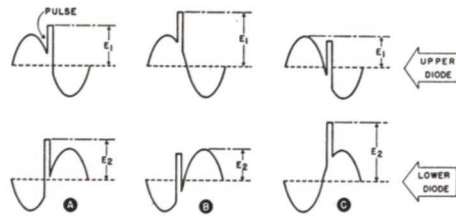

FIG. 31. Possible phase relationships in discriminator output.

output voltage of the discriminator circuit is fed to the R_4 - C_4 network (Fig. 30), and the voltage built up across C_4 by this control voltage is what is applied to VT_4 as a control bias. Since the R_4 - C_4 network has a fairly long time constant, a voltage difference must exist across R_1 - R_2 for several lines before the voltage across C_4 will change appreciably; and, of course, tube VT_4 does not learn of the change until the voltage across C_4 has reached its new level. Therefore, if only one or two pulses get out of line, normal pulses will come along to restore conditions to what they should be before the bias on tube VT_4 can change appreciably. The effect is that one or two bad pulses may change the

bias very slightly, but not enough to make any real difference in the operation of the circuit.

Should the sweep oscillator drift off frequency, however, it will get out of step with a number of the pulses, with the result that there will be time for the voltages across C_4 to change and hence for the reactance tube to pull the sweep oscillator back into frequency. Effectively, therefore, we have a circuit that uses the average of the sync pulses to control the output of the sweep oscillator. Because of the time constant network through which the control voltage is applied to the reactance tube, the circuit will tend to ignore irregularities in just a few of the pulses.

SAW-TOOTH A.F.C.

The a.f.c. system we have just described operates with a sine-wave oscillator. To get the sweep signal, this sine wave must be "treated" specially—it is squared and differentiated before application to the discharge-shaping network. To avoid this, many manufacturers desire to operate from either a blocking oscillator or a multi-

vibrator circuit rather than a sine-wave type. Therefore, a somewhat different form of a.f.c. system has been developed for use with these oscillators. Since both these oscillators can be controlled by varying the bias voltages applied to them, it is unnecessary to use a variable-inductance or variable-capacity tube; instead, the simpler system shown in Fig. 32 is usable.

Here, the sync signals are fed through the transformer T_1 and are applied to the two diodes VT_1 and VT_2 in such a way that the voltages applied to the tubes are equal and of opposite polarities. (Some manufacturers use triode tubes instead of diodes as VT_1 and VT_2 ; in such a case, the grid is tied to the plate to make a diode of the tube.) The circuit is arranged so that the plate of VT_1 is made positive at the same moment as the cathode of VT_2 , so both tubes conduct strongly when the sync pulses are applied. As a result, the condensers C_1 and C_2 are charged the first time the tubes conduct. They then place a bias on the system such that the plates of both VT_1 and VT_2 are

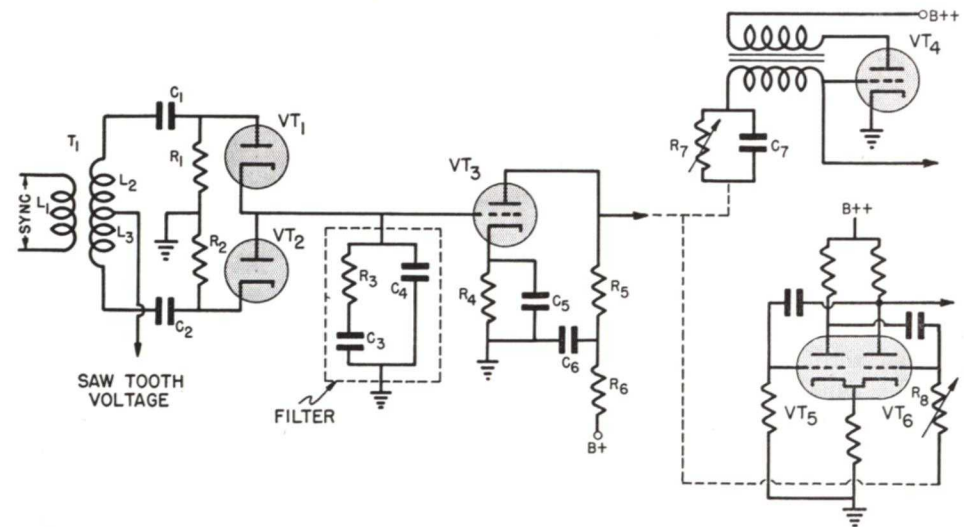

FIG. 32. A saw-tooth a.f.c. sync-locking network.

negative with respect to their cathodes except when the pulses are applied.

A small saw-tooth voltage is applied to the center tap of the secondary of T_1 . This saw-tooth voltage can be obtained from anywhere in the sweep circuit beyond the wave-shaping circuit; it is customary to use a portion of the sweep output voltage for this purpose.

The bias produced by the charges on C_1 and C_2 is just enough to prevent tubes VT_1 and VT_2 from conducting when only the saw-tooth voltage is applied to them. Thus, this voltage has no effect on the circuit except when the sync pulses are applied.

In fact, the saw-tooth voltage has no effect at all when the sweep system is operating properly, because the circuit is arranged so that the sync pulses occur just as the retrace of the saw-tooth crosses the zero axis—at the points marked X in Fig. 33. Hence, the saw-tooth voltage has no effect on the diodes even when they are conducting as long as the sweep oscillator is operating at the proper frequency.

Because of the symmetry of the circuit, the mid-point between the plate of VT_2 and the cathode of VT_1 will be at ground potential as long as the two tubes conduct equally. Therefore, no voltage will be applied to the filter $R_3-C_3-C_4$.

However, if the saw-tooth gets out of step with the sync pulses, the tubes will no longer conduct just as the retrace of the saw-tooth voltage goes through zero but will instead conduct when the retrace is above or below zero. If, for example, a sync pulse occurs when the retrace has not yet reached zero, the saw-tooth voltage and the sync pulse voltage will add together for VT_1 , increasing the plate voltage on this tube and making it conduct more than usual. On the other hand, the saw-tooth voltage will subtract from the pulse voltage applied

to VT_2 , causing the plate current of this tube to decrease. As a result, the voltage at the mid-point between the plate of VT_2 and the cathode of VT_1 will rise above ground potential, thus causing a positive voltage (with respect to ground) to appear across the filter. This voltage will increase the bias on VT_3 in the positive direction,

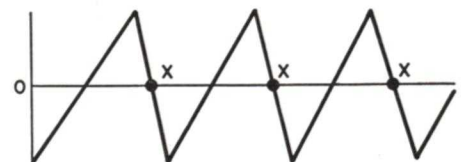

FIG. 33. The sync pulses occur at points X when the horizontal oscillator is in sync.

causing this tube to draw more plate current and hence produce a higher voltage drop across resistor R_5 .

On the other hand, if a sync pulse occurs after the saw-tooth retrace has gone below zero, the voltage applied to VT_1 will be decreased and that applied to VT_2 will be increased. As a result, the voltage at the midpoint between the plate of VT_2 and the cathode of VT_1 will drop below ground potential (with respect to ground) and a negative potential (with respect to ground) will be produced across the filter. This voltage, applied to the grid of VT_3 , will cause a reduction in its plate current and so decrease the voltage across R_5 .

The voltage across R_5 can be applied either to a blocking oscillator or to a multivibrator. The VT_4 circuit shown here is a typical blocking oscillator; that in which VT_5-VT_6 are used is a multivibrator. In either instance, the voltage across R_5 is applied in the proper grid circuit as a bias. When this voltage is fixed by the normal operation, the oscillators will both operate at the frequencies determined by the time constants of their grid circuits. On the other hand, when this average bias is changed, the oscillators

will be forced to fire sooner or fire later, depending on whether the voltage is more positive or more negative. Thus, the oscillators can be speeded up or slowed down and maintained in step with the sync pulses.

Once again, an important action occurs in the filter. Condenser C_4 and the series combination R_3-C_3 tend to delay the application of the signal change to the amplifier VT_3 . Irregular sync pulses and noise pulses cannot build up sufficient voltage across C_4 to cause any great change in the bias that is eventually applied to the sweep oscillators, so this system is also relatively unaffected by noise.

SIMPLIFIED SAW-TOOTH A.F.C.

Fig. 34 shows an even simpler a.f.c. system that may be used to control a blocking oscillator.

Here, tube VT_1 is a sync amplifier tube after the clipper. In the plate circuit of this tube, the signal path divides: part of the signal is fed directly from the plate to an integrating network from which the vertical control pulse is secured, and the rest is fed to the horizontal pulse circuit shown in Fig. 34. Notice that no differentiating network is used in this circuit to separate the horizontal pulses from the vertical pulses. Instead, the transformer primary circuit

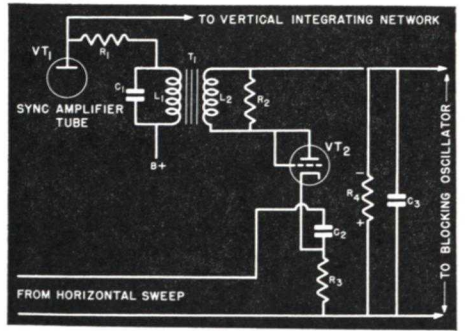

FIG. 34. Simplified saw-tooth a.f.c. system.

L_1-C_1 is tuned to resonate at the frequency of the horizontal sync pulses. It will therefore be forced into oscillation by the horizontal sync pulses and will produce a sine wave in step with each pulse.

This sine-wave voltage that is manufactured from the sync pulses (Fig. 35A) is applied through the transformer to the diode tube VT_2 .

In addition, the saw-tooth output of the sweep circuit (Fig. 35E) is applied to the differentiating network C_2-R_3 ; the resulting pulses that are produced across R_3 are in the cathode circuit of VT_2 .

Therefore, both the sine-wave sig-

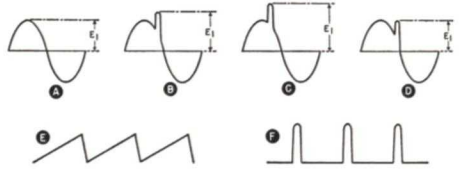

FIG. 35. Possible phase relationships in circuit shown in Fig. 34.

nal shown in Fig. 35A and the differentiated pulses shown in 35F are applied to this tube. The two will combine to produce the signal shown in Fig. 35B. If we choose the proper value for resistor R_4 , which is in the grid circuit of the blocking oscillator, the average voltage produced across this resistance will be such that the circuit will stabilize around the desired operating point.

However, if the frequency of the sweep oscillator drifts in one direction, the pulses will move up on the sine wave as shown in Fig. 35C, thus increasing the voltage across R_4 . This will increase the bias across R_4 in the negative direction, thereby slowing down the speed of the blocking oscillator so that the pulses can move down on the sine wave to the proper position.

On the other hand, should the blocking oscillator shift in the other

direction, the pulse will move down too far on the sine wave as shown in Fig. 35D; this will reduce the drop across R_4 and allow the blocking oscillator to speed up.

The circuit is protected from noise pulses in two ways. Changes in amplitude of the sync pulses caused by noise have no effect, because the amplitude of the sine wave that is used in the control circuit is determined by the Q of the tuned circuit and not by the amplitude of the pulse fed into it. The effect of a variation in pulse width caused by noise is eliminated by C_3 in Fig. 34. Should the pulse width vary, the position of the sine wave would shift with respect to the position of the pulse obtained from the output of the sweep circuit. This would cause a sudden change in the voltage across R_4 . However, condenser C_3 must be charged by the average voltage across R_4 before any change can be produced in the voltage applied to the grid of the blocking oscillator; any sudden change in the voltage across R_4 will be ignored, because the condenser cannot charge fast enough to follow very sudden changes. Therefore, only the average change in

the voltage across R_4 will be passed on to the grid circuit of the sweep oscillator.

PULSE WIDTH SYSTEM

The next locking circuit we are going to describe is rather different from all the others in that it sets up a system in which the width of a pulse is used to control the blocking oscillator or multivibrator circuit.

The basic circuit for a typical arrangement of this kind is shown in Fig. 36. Here, tube VT_2 is the blocking oscillator. The transformer T_1 is an auto-transformer rather than the two-winding type, but otherwise the circuit is that of a conventional blocking oscillator. The grid condenser is C_9 ; the resistors R_9 and R_7 make up the grid resistance that determines the "hold" range of the circuit.

Condenser C_{10} and resistor R_{11} make up the charge-discharge circuit that is operated by this blocking oscillator. At the output, across C_{10} , there is the usual saw-tooth voltage, which is applied to the rest of the sweep chain through coupling condenser C_{11} . In addition, a portion of this saw-tooth voltage is taken off and brought back

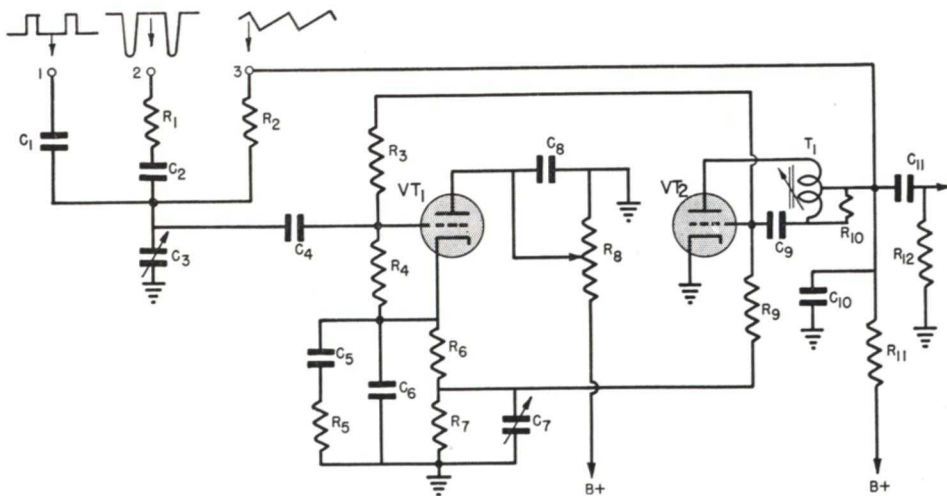

FIG. 36. Pulse-width horizontal sync-locking system.

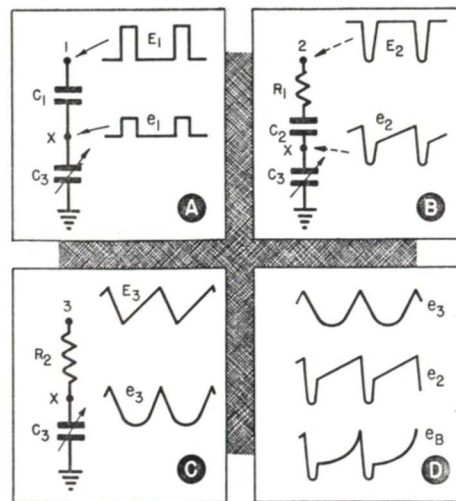

FIG. 37. Effects of shaping networks in Fig. 36.

to point 3, from where an integrated product of it is applied to the grid of the control tube VT_1 . Three different pulses are applied through R-C networks to the grid of VT_1 —in addition to the saw-tooth, sharp pulses are applied to point 2. It is important to note that these pulses which are obtained from across the yoke of the electromagnetic sweep system, are not square—they represent halves of sine waves. However, they are of high amplitude, because they are produced by the inductive kick that occurs when the deflection coil goes into oscillation during the sweep retrace.

Finally, the horizontal sync pulses from the clipper circuit are applied to point 1.

The networks through which these three different signals are applied to VT_1 have the effect of changing the shapes of the signals. Let's see what each does.

As shown in Fig. 37A, the network C_1 - C_3 sets up a voltage divider for the sync pulses, so that sync pulses of rather small amplitude are developed across C_3 for application to the grid of VT_1 . Thus, the voltage at point X

as a result of the sync pulses is represented by the voltage e_1 in Fig. 37A.

The sine-wave pulses that are applied from the output circuit through path 2 are applied to what amounts to an integrating network made up of R_1 , blocking condenser C_2 , and the condenser C_3 . The integration of these pulses produces the trapezoidal wave e_2 in Fig. 37B.

Finally, the saw-tooth wave applied through path 3 is integrated by R_2 - C_3 , with the result that the parabolic wave e_3 is produced.

These three signals combine into one before they are applied to VT_1 , since all are developed across C_3 . Fig. 37D shows the result of combining only e_2 and e_3 . As you can see, the resultant signal e_B has a shape similar to the trapezoidal wave, but because of the parabolic wave, it comes up to a very sharp peak and then falls off very abruptly.

The phases of the various signals are arranged so that the midpoint of the sync pulse will be at the peak of the resultant signal e_B if the horizontal oscillator is operating at the proper frequency. Thus, the three signals will combine to form the signal shown in Fig. 38B when the sweep circuit is operating properly. Because of the extremely steep drop-off in e_B , approximately half the sync pulse (shown by broken lines) is cut off when the signals are combined.

The lines marked "cut off" in Fig. 38 show the grid voltage level below which tube VT_1 is cut off. As you can see, only the sync pulse portion of the combined signal is above cut-off; under normal conditions, which are shown by Fig. 38B, the part of the sync pulse that is above cut-off is only half as wide as the original sync pulse.

If the horizontal oscillator drops out of sync, the sync pulse may occur

Lesson Questions

Be sure to number your Answer Sheet 56RH-3.

Place your Student Number on every Answer Sheet.

Send in your set of answers for this Lesson, immediately after you finish them, as instructed in the Study Schedule. This will give you the greatest possible benefit from our speedy personal grading service.

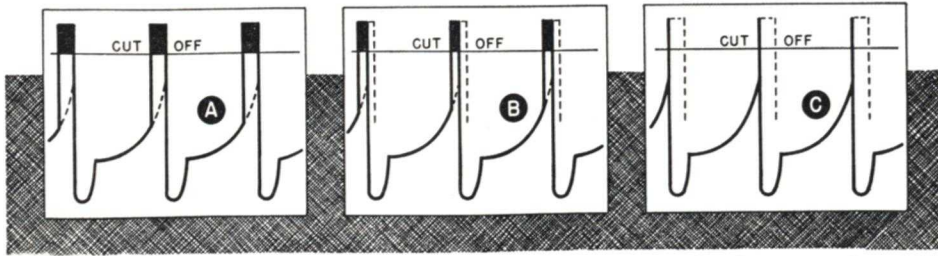

FIG. 38. How phase differences change the width of the control pulse in a pulse-width system.

before or after the right position with respect to the peak of signal e_B . Fig. 38A shows what happens when the pulse occurs early; as you can see, the width of the sync pulse above cut-off is increased. If the pulse occurs late, as Fig. 38C shows, the pulse width above cut-off is decreased.

The amount of time that tube VT_1 can conduct depends on how wide this pulse happens to be. The wider it is, the longer the tube conducts, and the more condenser C_7 in the cathode circuit is charged. The average voltage across this condenser is applied in the grid circuit of the blocking oscillator, so the blocking oscillator frequency is controlled as in the other arrangements we have studied earlier. If the blocking oscillator speeds up, the peak in e_B will occur before the sync pulse, so a narrower pulse will be fed to VT_1 . This means that the drop across R_7 will become less, which is the same as making the grid of the blocking oscillator more negative (less positive); therefore, the oscillator will slow down. If it runs slow, on the other hand, the pulse width will increase, so the drop across R_7 will also increase. In effect, therefore, a positive bias will be applied to the grid of the

blocking oscillator, which will then speed up.

As in the other control circuits we have studied, a filter system is used to make the system follow the pulse averages. The charging of C_7 and the filtering provided by C_6 and the C_5 - R_5 network serve to prevent any sudden change.

The hold control of this circuit consists of the variable resistor R_8 in the plate circuit of the control tube VT_1 . Varying R_8 changes the normal plate current of VT_1 through R_7 and thus sets the operating point of VT_2 .

The range over which the hold control operates is determined by the setting of adjustable condenser C_3 . Varying C_3 will set the amount by which the grid of VT_1 can be driven into the conducting region and will hence also change the range of the hold control. Some sets also use a variable condenser as C_7 , an arrangement that offers an extra control over the range of the hold control. When more than one control of this kind is used, one of them (usually the variable resistor in the plate supply) is brought out to the front panel of the receiver to furnish a fine control for the range, and the others are used to give a coarse setting of the range.

1. What is the difference between "clipping" and "segregating" the sync signals?
2. If a square-wave signal is fed into an R-C circuit having a short time constant, will the signal pulses across the resistor be: *square*; *saw-tooth*; *sharply peaked*; *parabolic*?
3. Why must the signal be in its d.c. form before it can be clipped?
4. To get a strong signal for clipping, is the signal usually taken from: 1, *the video detector*; 2, *the first video amplifier*; 3, *the output video stage*?
5. What advantage does a pentode clipper have over single-triode types?
6. If the clipper output is to be used to control the grid of a blocking oscillator with no intervening amplifier stage to be used, what phase must the output pulses have?
7. Why must the RC circuit used for segregating the vertical pulse have a long time constant?
8. Which edge of a horizontal sync pulse is used to produce synchronization?
9. In a simple trigger sync system that uses amplitude limiting in the sync amplifiers, which of the following will upset horizontal synchronization: 1, *noise increasing the amplitude of the sync pulse*; 2, *noise moving the lagging edge of a sync pulse*; 3, *noise moving the leading edge of a sync pulse*?
10. Why are horizontal sync locking circuits designed to operate on the average of the sync pulses?

Be sure to fill out a Lesson Label and send it along with your answers.



TO BE INDEPENDENT, PRACTICE ECONOMY

To become truly independent, the practice of *simple economy* is necessary. And *economy* requires neither superior courage nor great virtue. It requires only ordinary energy and consistent attention. Essentially, *economy* is the spirit of orderliness applied to the administration of your own *personal affairs*. It means management, regularity, prudence, and the avoidance of waste.

Economy also requires the power to resist present gratification of your wants, in order to secure future benefits. And even wild animals practice this *economy* when they store food for the winter!

Yes—the practice of *economy* is necessary unless and until you figure out some fool-proof way to make money faster than you can spend it! I'll admit that a few men have been able to do this—but until you can discover this golden secret, your best road to independence will be the day in and day out practice of *reasonable economy*.

J.E. Smith