

**HOW TO CHOOSE AND INSTALL
REPLACEMENT PARTS**

Finish

47RH-2



NATIONAL RADIO INSTITUTE

WASHINGTON, D. C.

ESTABLISHED 1914

STUDY SCHEDULE No. 47

For each study step, read the assigned pages first at your usual speed, then reread slowly one or more times. Finish with one quick reading to fix the important facts firmly in your mind. Study each other step in this same way.

- 1. Replacement Parts Pages 1-2
The kinds of parts, what to stock, and where to buy parts are covered here.
- 2. Power Transformers Pages 2-9
Practical information on how to determine whether a transformer is just overloaded or has been damaged. The requirements for replacing and a discussion of how to replace power transformers conclude this section.
- 3. Iron-Core Chokes and Audio Transformers Pages 10-14
It is a problem to get a replacement if a duplicate is not available. However, once you know the characteristics which must be considered, it is possible to choose a satisfactory replacement.
- 4. R.F. and I.F. Transformers Pages 14-18
These coils may be replaced by exact duplicates or you can have duplicates wound for you by firms specializing in this service. Also, replacement primaries can be used in some cases.
- 5. Replacing Condensers Pages 19-21
Next to tubes, condensers require the most frequent replacement. However, a relatively small stock will serve for most cases, as is pointed out here.
- 6. Replacing Resistors Pages 21-24
This section gives information on replacing both fixed and variable resistors. Practical hints are given on how to make a small stock do for most jobs.
- 7. Replacing Loudspeakers Pages 25-28
Speakers may be repaired by replacing the cone or field coil, or the entire speaker may be replaced. The best practice to follow depends on the condition of the original, the ease of replacement, and the availability of replacements. There are firms specializing in speaker repairs—many servicemen use these services.
- 8. Answer Lesson Questions and Mail Your Answers to N.R.I.
- 9. Start studying the Next Lesson.

HOW TO CHOOSE AND INSTALL REPLACEMENT PARTS

Replacement Parts

WHILE the final steps in making a repair — removing the defective part and obtaining and installing a replacement—are purely mechanical, it is possible to waste a great deal of time in taking these steps unless you know what to buy, where to buy it, and how to install it. We will give you this important information in this lesson, along with a number of hints on testing parts. Let's start by learning something about the kinds of radio parts which are usually available.

KINDS OF REPLACEMENT PARTS

Replacement parts fall into three groups: exact duplicate replacements; universal replacements; and general replacement parts.

Exact Duplicate Parts. These parts are exact duplicates of the originals, both physically and electrically.

Universal Parts. There are a number of universal radio parts so designed that, with minor physical or electrical alterations, they can be used as replacements for a wide variety of radio parts. For example, volume controls come with extra-long shafts. Once you have chosen a control of the proper electrical characteristics, you can make it fit the receiver by cutting off the shaft to the required length. Thus, the same control can be used in any receiver which its electrical characteristics will fit.

As another example, output transformers come with tapped secondaries; by choosing the proper taps, you can match practically any loudspeaker to almost any output tube (or tubes).

General Replacement Parts. Final-

ly, we have parts, such as tubes, resistors, and condensers, which can be used in any receiver as long as the proper electrical characteristics are chosen and as long as there is sufficient room for the parts.

We include, among these, parts not designed for the particular radio, but which can be used by making some slight change in the original circuit to "fit" the new part characteristics. Changes of this kind are rare, as the widespread distribution of exact duplicate and universal replacement parts generally makes it possible to make a direct replacement.

STOCKING RADIO PARTS

You can start a radio service business with a surprisingly small stock of parts. However, you will want to build up your stock gradually, both so you can cut down the number of trips or orders to the parts suppliers and so you can render the fastest possible radio service.

When you start in business, you will need a kit of resistors, a small number of electrolytic, paper, and mica condensers, a stock of tubes, an assortment of pilot lights, and a certain amount of hook-up wire and hardware. With this small stock as a beginning, you can increase gradually the amount and variety of these parts. Also, you can add items like universal output transformers, a volume control kit, i.f. transformers, tube sockets, dial cords and belts, and an assortment of knobs.

Some servicemen make the mistake of acquiring too large a stock. It is not wise to invest much money in slow-moving parts. Increase the quantity

and variety of your stock only as your service experience indicates the need for such expansion. At the beginning, ask your local distributor to help you choose parts which, according to his sales records, move rapidly in your area. This is particularly important in the case of tubes. There are about a thousand different types of radio tubes, yet perhaps in your district only seventy-five to one hundred types are widely used.

WHERE TO BUY RADIO PARTS

There are many sources of supply available to the serviceman. Perhaps the best known are the large mail-order radio parts suppliers, who carry very complete stocks of parts and who can usually obtain any special parts you may need. In large cities there are also radio parts supply houses and distributors who carry a wide selection of radio parts.

In addition, there are distributors scattered throughout the country who handle various popular makes of radio receivers. Exact duplicate parts for these receivers can be obtained through these distributors. Where there are no distributors, parts can sometimes be obtained directly from the factory. Also, many *parts* manufacturers (condenser and resistor manufacturers, etc.) deal directly with servicemen, although in recent years, mail-order and local parts supply houses have acted

as distributors for these lines.

Collecting Service Data. All servicemen collect wholesale parts catalogs, both to locate sources of supply and to obtain information on the electrical and physical characteristics of different parts. Be sure to collect all the volume control guide booklets, vibrator replacement guides, transformer replacement guides, tube charts, and other service data which are available from your local distributors or supply house. Many of these are free, while others are sold for just a few cents.

► While we are on the subject of collecting information—try to get all possible information on radio receivers themselves. You will find that your parts distributor will help you obtain service manuals.

Many set manufacturers publish their own manuals, which are kept up to date by supplements or come out in yearly editions. You may find it desirable to get those covering any particular brands of receivers which predominate in your locality.

Let us turn now to certain specific radio parts and learn more about the problems of obtaining the proper replacement and installing it quickly. We shall deal chiefly with transformers, condensers, resistors, and loudspeakers, as other parts—line cord resistors, tubes, batteries, etc.—are replaced most generally by exact duplicates.

Power Transformers

There are two ways in which a transformer can fail: 1, a winding may open; or 2, a short circuit may develop.

The first is rare, as electrolysis seldom occurs in a sealed transformer, and an open is seldom caused by an overload. If an open occurs, the fact is

obvious, since one of the secondaries will not deliver voltage. A continuity check with an ohmmeter will lead you to the defective winding.

Watch particularly for an open center tap. You may still have continuity across the entire winding, so make a

check to the center tap from each end of the winding.

► A short circuit is the usual transformer defect, and it is invariably caused by excessive heat. If too much current is drawn from a transformer winding—that is, if the transformer is overloaded—so much heat will be produced in it that the paper insulation between the layers of wire in the winding will char (carbonize). Since carbon is a fairly good conductor, the winding, or part of it, will be short-circuited. Once an internal short has developed, the transformer must be rebuilt or discarded. Under normal conditions, it is not economical to rebuild, so a replacement would be installed.

CHECKING FOR AN OVERLOAD

Your nose will first discover a short circuit or an overload. The pungent odor of burning enamel and paper insulation is unmistakable. Smoke may come from the transformer, and perhaps some tar or wax sealing compound will boil out of it.

These symptoms indicate that the transformer is overheated, but not necessarily that it is damaged. Simple tests will show where the trouble lies.

► When you find an overheated or smoking transformer, turn off the set and remove all the tubes, including the rectifier. Now turn the set back on and wait to see if the transformer cools off.

If the transformer *does* cool and stop smoking, it has been overloaded but is probably not seriously damaged. The overload was probably caused by a B supply defect, the effects of which were stopped by removing the rectifier tube. Repairing the defect will usually restore normal operation.

► On the other hand, if the transformer continues to overheat with the tubes out, it is being *overloaded* by shorted secondary leads or by a filament circuit short, or else it has been

damaged by: 1, a B supply defect; 2, operation on the wrong power line frequency; or 3, by an internal transformer defect.

If you live in a district with 25-cycle power, check the receiver label to see if the transformer is meant for 60-cycle operation. Such a transformer will draw too much primary current from a 25-cycle line, and eventually will be ruined. The only cure is to replace it with a transformer designed to operate on 25-cycle power.

Shorted Leads. Next, remove the chassis from the cabinet. Then, with the tubes out, turn the set on and examine the bottom of the chassis for signs of arcing between the transformer secondary leads. Push the wires around with an insulated probe or stick. If you see or hear an arc, the insulation probably has become frayed on the wires. Tape or replace the leads in order to cure this.

Also, examine the rectifier tube socket. An arc may have occurred between a plate terminal and the chassis, between the two plate socket terminals, or from one of the rectifier filament socket terminals to the chassis. Often the arc can be seen or its charred path can be observed on the bottom of the socket.

If the rectifier has a wafer socket, the arc path may be between the two wafers of the socket and so may be invisible. If the transformer continues to overheat, disconnect the leads going to the rectifier socket to see whether this removes the overload.

Replace any socket which shows evidence of arcing, as the carbonized path is sure to give further trouble.

If there are no apparent shorts but the transformer continues to overheat, it is probably damaged.

A Transformer Short Checker. If you have taken the set to your shop, you can test the transformer with the

simple checker shown in Fig. 1. This device consists of a 60-watt lamp bulb in a socket wired in series with a power cord and an outlet. To use it, remove the tubes and pilot lamps from the radio and plug the set into the outlet. The lamp then will be in series with the primary of the power transformer and will indicate the amount of primary current.

Under these conditions, if the set is normal there will be so little drain on the power transformer that the lamp will barely glow—if it lights at all. If the lamp burns brightly, however, there is a short circuit between the high-voltage wires or in the rectifier socket, or else the transformer itself is defective. Examine the high-voltage wiring for shorts, then disconnect the leads going to the rectifier tube socket to see if the lamp glow decreases. If it does, the socket is defective. If not, the transformer itself is defective.

Circuit Defects. Whether you have an overheated transformer or a damaged one, be sure to clear up any overload conditions existing in the radio. Otherwise, the transformer (or its replacement) is certain to be damaged.

► Short circuits in the filament circuits are rare, as the low voltage is not likely to cause insulation breakdowns and there are usually no condensers in these circuits. One possibility of a short circuit is a grounded pilot light socket in a receiver which has a grounded center tap on the filament winding. This shorts half the filament winding. (However, many modern receivers use the chassis as *one side* of the filament circuit, so the pilot light is deliberately grounded to complete the circuit. Don't confuse this intentional ground with a short circuit.)

► On the other hand, the high voltages in the B supply cause frequent breakdowns, particularly of by-pass and filter condensers.

To check the B supply circuit, first test all the tubes, looking especially for shorted elements in the rectifier and power tubes. Then, *with the set turned off*, check the resistance from the *cathode* terminal of the rectifier socket to the chassis with an ohmmeter. Be sure to observe polarity. The *positive* ohmmeter terminals must go to the B+ side of the circuit. (When in doubt, reverse the leads after taking a reading. Then, the polarity permitting the *higher resistance* reading is the correct one.)

The receiver diagram will show what the resistance should be. Usually, the resistance between B+ and B— should be only the leakage of the electrolytic filter condensers (over 100,000 ohms).

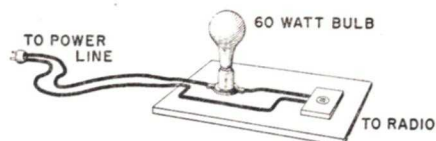

FIG. 1. A simple lamp device, used to check for shorted power transformer windings.

(Some receivers have bleeder resistors which reduce the reading to some value between 5,000 and 25,000 ohms.) If the reading is less than that which is expected, look for a short. Such a short could overload the transformer and also could be the cause of a shorted rectifier tube. The electrolytic filter condensers, the most likely sources of trouble, should be checked first.

CHOOSING THE REPLACEMENT

When you have determined definitely that the transformer is defective and have cleared up any overload conditions, the next step is to make the replacement—preferably with an exact duplicate transformer. Such a transformer may be obtained from the distributor of the receiver, from the manufacturer, from a wholesale mail-order house, or from one of the large trans-

former manufacturers who specialize in exact duplicate replacements. When you order, give the following information:

1. The make of the receiver.
2. The model number of the receiver.
3. A complete list of the tubes used in the receiver.

If your customer does not wish to wait while you send for an exact duplicate, or if none is available, you must choose a universal or general-purpose replacement transformer which has physical and electrical characteristics similar to the original.

ELECTRICAL REQUIREMENTS

To choose a suitable universal replacement transformer, you need to know the ratings of the windings on the old transformer. You can usually learn this from the service information on the receiver, from your parts distributor, or from catalogs of transformer manufacturers. They list receivers by make and model number and recommend as replacements specific transformers of their line. (If you cannot obtain the recommended transformer, its characteristics, given in the manufacturer's listing, at least will give you the information you want.)

Check these points to see that the proper transformer is obtained:

1. Primary. The transformer must be designed for the power line voltage and frequency. The frequency rating is usually given in the data on the primary winding.

The original transformer may have had taps on the primary to adjust it for a power line voltage range of, say, 100 to 125 volts. Most universal replacements will not have these taps; if not, wire the replacement primary directly to the power line terminals.

2. Wattage Rating. If the proper voltages and currents are delivered, you need not worry about the wattage

of a transformer. Just ascertain that *each* winding is properly rated for the load it must carry.

3. Filament Windings. There will be from one to four filament windings, each with a voltage and current rating. The voltage rating depends on the types of tubes to be connected to the winding, and the current rating depends on the total current drawn by them.

Both the voltage and current demand for a winding can be found by determining *which* tubes are connected to it, whether they are in series or parallel, and (from a chart) what the requirements are for each tube. When tube filaments are in *parallel*, the filament winding must supply the voltage required for any *one* of the parallel tubes, while the current will be the *sum* of all of the current ratings of that group of tubes. When tube filaments are in *series*, the voltage required is the *sum* of all the voltage ratings (plus any series resistance drops), while the current rating will be that of a single tube in the group.

Of course, the current rating of the winding can be any amount equal to or *above* the current drawn by the tubes—this rating just gives the *maximum current* the winding can deliver without overheating.

► Most universal replacement transformers come with center taps on some of the filament windings. If the original transformer has no corresponding center tap, just cut this tap off or wrap the end with tape.

► Some very old receivers used a center tap on the rectifier tube filament winding as the B+ connection. Generally, replacement transformers will not have such a center tap, but you can make the B+ connection to either side of the rectifier tube filament circuit.

► It is perfectly all right to use a transformer having extra filament windings.

Just tape the extra leads or ignore the terminals on the transformer.

4. The High-Voltage Secondary. The high-voltage secondary must furnish sufficient voltage to give the proper B and C voltages, and must have a current rating equal to or greater than the amount drawn by the tubes and any bleeders.

► You'll have to be careful in figuring the proper voltage rating for this winding. If the voltage is too high, it may damage the filter and by-pass condensers and introduce excessive regeneration, while a voltage below normal may lower the sensitivity and output of the receiver.

Many universal replacement transformers are designed for average receiver conditions, and you need know only the number and types of tubes to get approximately the right transformer. For example, you can buy a transformer designed for a 5- or 6-tube receiver and the rating of the high-voltage secondary usually will be close to the requirements for the receiver.

It is better, though, to compute the rating from the normal operating voltages for the tubes used. Radios differ somewhat in their actual applied voltages, but a tube chart will show you the probable voltages used. Any set with 71A, 6G6, or 6A4 output tubes will need plate voltages of about 180 volts. If the output tubes are 42, 6F6, 6V6, or 6L6, the voltage may be 250 volts, but can be higher (depending upon whether the output is class A, AB, or B). Certain special class B tubes take voltages up to 400 volts. Most other common power tubes take 250 volts as the plate supply.

When the output tubes are triodes, the C bias voltage will be 40 or 50 volts and should be added to the plate voltage supply. You can ignore the bias requirements for pentode and beam power tubes.

If the speaker field is used as a choke in the B supply circuit, allow about 100 volts as the drop across it. Adding this value to the plate voltage requirement gives the d.c. voltage needed at the filter input, which is approximately equal to the a.c. peak voltage when a condenser input filter is used. Since transformers are rated in r.m.s. values, multiply this filter input voltage by .7 to get the approximate r.m.s. rating necessary to give this peak value. Then, add about 50 volts to this r.m.s. value to approximate the rectifier and transformer secondary drops. The total will be the r.m.s. rating for one-half the high-voltage winding.

For example, if we need 250 volts for the plate supply and 100 volts for the field, we need 350 volts d.c. The r.m.s. voltage needed is $350 \times .7$, or about 245 volts. Adding 50 volts to this gives a rating of about 300 volts for one-half the high-voltage winding, or 600 volts for the entire winding. This is a common rating for average size receivers.

The current requirement for the high-voltage winding can be found by adding the plate and screen grid currents of all the tubes except the rectifier. If a bleeder resistor is used, add about 20 milliamperes to this value. The total will be near the proper rating for the high-voltage winding. To be safe, you can choose a transformer with a current rating higher than this value if one is available.

MECHANICAL REQUIREMENTS

Several typical transformer mountings are shown in Fig. 2. The type shown at A is mounted above the chassis, with the leads going down through chassis holes. The important dimensions are the height (if the cabinet is small) and the mounting centers. (By mounting centers we mean the distance between the centers of the holes through which pass the bolts holding the transformer case to the

chassis.) This measurement may be made with a pair of calipers by spreading them until their points reach to the centers of each pair of holes, then checking the spread on a ruler.

The types shown in B and D mount through a large hole so part is above and part below the chassis. The dimensions of the cut-out area on the chassis are important, as well as the mounting centers. When the replacement listing does not give the "window" size needed, check the mounting centers and core sizes. If they are simi-

lar, showing their colors and their connections. Then, to be sure you get the new leads on the right places, cut the old transformer leads near the transformer, leaving the other ends of the leads still connected in the radio. If the transformer is a lug type like that in Fig. 2D, unsolder the leads at the lugs. Some servicemen fasten marked slips of paper to the leads to identify them.

► If you have an exact duplicate transformer, the replacement will be easy. Just unfasten the original trans-

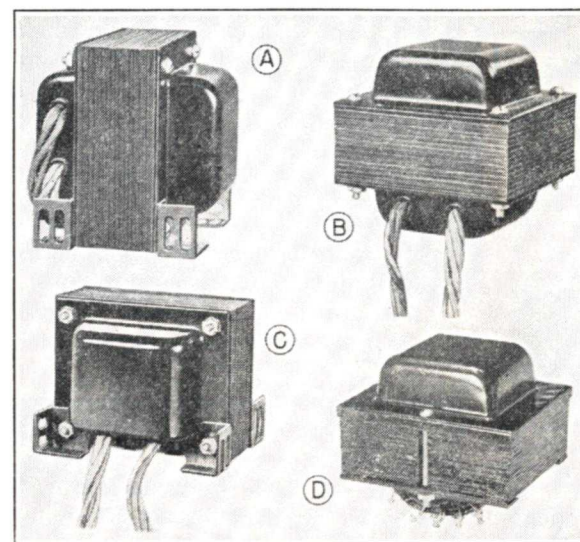

Courtesy Thordarson
Elec. Mfg. Co.

FIG. 2. Typical replacement power transformers. The style shown at A, B, and C is a universal type; it may be mounted in many positions by moving the mounting feet to the proper corners. The style at D represents a "half-shell" transformer, which is mounted so that the lugs pass through a large chassis cut-out.

lar, then the winding dimensions will probably be similar.

Figs. 2A and 2C are two views of an above-chassis type with universal mounting brackets. These can be put on any of the transformer bolts in such a way that many mounting center distances can be accommodated.

TRANSFORMER INSTALLATION

Don't remove the defective transformer until you've obtained the replacement. This will make it much easier to identify the connection.

When you are ready to take out the defective unit, make a sketch of the

former, put the new one in place, and make the proper connections. If the new transformer has leads, they will be colored the same as those of the original, and you can easily find the proper connections from the leads you left in the radio. Remove identifying pieces of wire as you solder the new leads in place.

If the replacement has lugs, the lug positions will be the same as those of the original, and your sketch showing the colors of the wires connected to each lug will aid in your making the proper connections.

Universal Replacements. If the re-

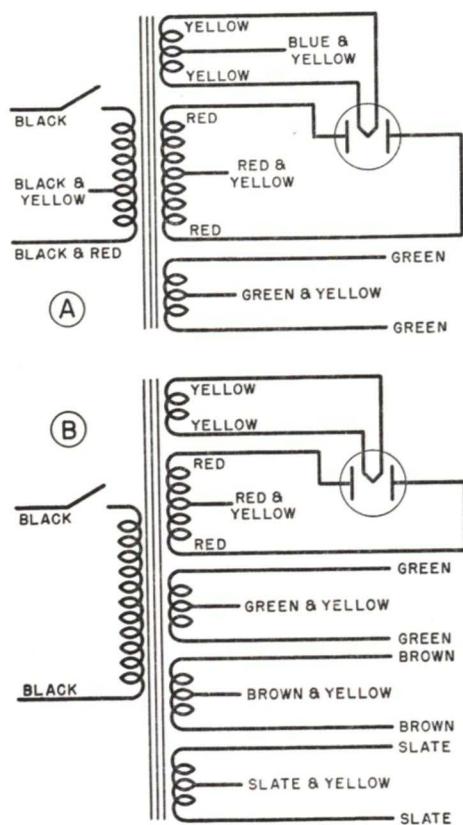

FIG. 3. The RMA standard color code for power transformer leads. Not all transformers have their leads colored according to this code, so watch for those having different arrangements.

placement is not an exact duplicate, mounting and connecting it may be more of a problem.

First, cut off the leads near the defective transformer and make an identification sketch of the connections, then remove the defective transformer and set the new one in its place. If the new transformer has universal mounting brackets, see if you can place it so the brackets fit over the original mounting holes. If not, you will have to drill new holes.

► A universal transformer may be entirely different from the original in the color code of its leads or in its terminal arrangement. There should be a slip packed with the transformer which

will identify its terminals, and your sketch of the original transformer connections will show the proper connecting points. Any extra terminals can be ignored. Extra leads, such as unused center tap connections or extra filament windings, can be insulated with tape and tucked out of the way.

IDENTIFYING LEADS

If you have no lead identification slip for your transformer, you may be able to identify the leads from the standard R.M.A. color code for power transformers shown in Fig. 3—especially if it is a universal type made within recent years. However, there are many variations in the color codes used, particularly in transformers used in earlier receivers.

► If the color code is not helpful, you can identify the windings of an unmarked transformer with an ohmmeter and a simple lamp testing device.

First, use the ohmmeter to discover which leads show continuity to each

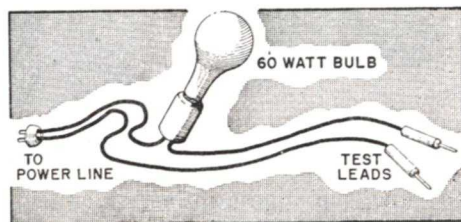

FIG. 4. A simple continuity tester.

other; these leads go to the same winding. Next, put a 60-watt light bulb in series with a power cord and test leads, as shown in Fig. 4. Separate the transformer leads so that their ends do not touch, then touch the test leads to each pair of wires which show continuity. When you put the test leads across filament windings, you will have a full, bright light; across the high-voltage winding, no light; and across the primary, a faint glow.

Once you have identified the primary, connect it to the 110-volt a.c. line and measure the voltages developed by the secondaries. This will identify each winding. Since you know from the lamp test which is the high-voltage winding, you need not measure its voltage unless you want to know what it is.

Remember that the voltages produced by a transformer with no load

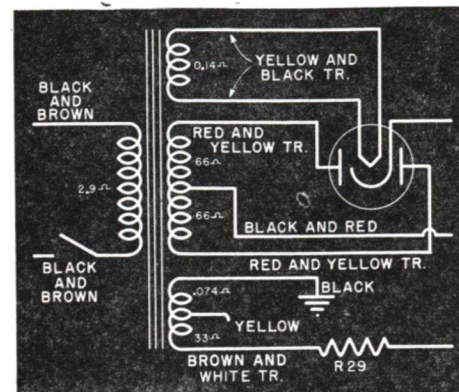

FIG. 5. A typical example of a transformer which is not color-coded according to the RMA code. Notice the special filament winding. Only an exact duplicate transformer can be used to replace this one.

connected to it may be somewhat higher than the rated voltages. Thus, a 6.3-volt filament winding may produce 7 to 7.5 volts with no load, while a 5-volt filament winding may produce 5.5 to 6 volts.

► When the resistance values are given on a diagram, as in Fig. 5, you can identify the windings with an ohmmeter. Notice that the transformer shown in Fig. 5 has a tapped filament winding. (A check of the circuit diagram of the receiver in which it was used shows that the tube filaments operate from the 6.3 volts produced by the .074-ohm winding, while a special tuning circuit indicator uses the total voltage produced by this secondary.)

Also notice that the color code is not the standard R.M.A. code.

Another example is given in Fig. 6. Here, two of the filament windings have about the same resistance, so the ohmmeter reading only identifies them as filament windings. If you did not have a wiring diagram to show the connections or voltages, you would have to measure the voltages to identify these windings.

AUTO-SET TRANSFORMERS

As the transformer, vibrator, and buffer condenser of an auto radio are usually designed to "work together," and since the transformer is usually in a shielded compartment of limited size, it is best to use an exact duplicate replacement. However, universal types are available. The auto-set transformer has only one secondary, and its voltage and current ratings are the

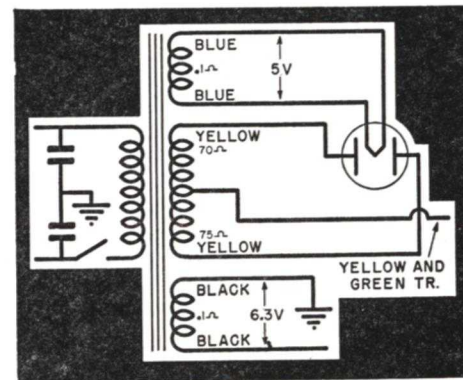

FIG. 6. Filament windings have such low resistances that an ohmmeter is not reliable as a means of distinguishing between these windings. Voltage measurements should be made to complete the identification.

only ones to consider. Follow the same rules as for the high-voltage winding of a power line transformer. Remember that the plate voltages range from 180 to 250 volts, and that the speaker field is never used as a choke.

Iron-Core Chokes and Audio Transformers

FILTER CHOKES

A properly moisture-proofed filter choke will rarely open or otherwise become defective unless subjected to a severe overload, such as one caused by shorted or leaky filter or by-pass condensers.

If possible, order an exact duplicate for ease in mounting. Simply ask for a filter choke for the make and model number of the receiver on which you are working. If you cannot get an exact duplicate, order one with about the same physical dimensions and mounting centers. If the original choke was shielded the replacement should also be shielded.

The resistance of a power supply filter choke is not important unless it is in the negative side of the circuit and the voltage drop across it is used for

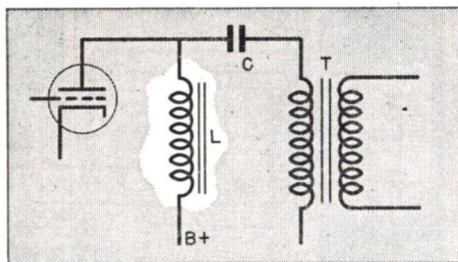

FIG. 7. A high-inductance choke, used as a plate load.

biasing. In this latter case, the resistance of the replacement should be approximately the same as that of the original part (which you may find on the wiring diagram).

Since high-capacity electrolytic condensers are now used universally in filter systems, an inductance of 10 henrys (or more) is satisfactory. Remember, however, that the choke inductance is figured for a particular d.c. current, and will be lowered if the current rat-

ing is exceeded. Thus, if a 60-ma., 10-henry choke is used in a 100-ma. circuit, the inductance may drop to 2 or 3 henrys, and the choke may overheat. You must use a replacement with a current rating equal to or somewhat higher than the actual current flow in the circuit to obtain a proper inductance value.

You can compute the current roughly by adding the normal cathode currents of all tubes (get these from a tube chart) with the exception of the rectifier. Add on 20 ma. if a bleeder system is used. Receivers using a power transformer and about six tubes will require a 60- or 70-ma. choke. Larger receivers will need a choke rated at 100 ma. or more.

In general, satisfactory chokes for a.c.-d.c. sets are obtained just by asking for a choke to use in an a.c.-d.c. set.

AUDIO CHOKES

High-inductance chokes are sometimes found in impedance-coupled a.f. amplifiers and in stages where a coupling transformer or load device is isolated as in Fig. 7. These chokes must have high inductance to pass on low audio frequencies and, like other chokes, the amount of inductance will depend on the d.c. current flow.

If an exact duplicate is not available, use a choke intended to operate in the plate circuit of the particular tube used in the stage, or choose one which has a current rating above the normal d.c. value of that tube.

The higher the inductance of your choke, the better the low-frequency response will be. However, remember that a high inductance means many turns, and the distributed capacity may reduce high-frequency response.

If the original choke was shielded,

the replacement should be also (to minimize hum pick-up).

INTERSTAGE AUDIO TRANSFORMER REPLACEMENTS

An interstage a.f. transformer is one which is used to couple two audio stages together. The windings may open, short, or become noisy. In such cases it is best to use an exact duplicate, for then the response of the receiver will be unchanged and mounting difficulties will be eliminated. When ordering, state the make and model number of the receiver and the position of the transformer in the circuit (first a.f. or second a.f. transformer).

If a duplicate is not available, use an a.f. transformer with a step-up

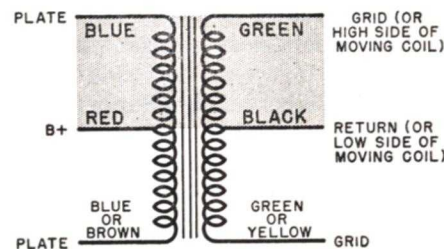

FIG. 8. The RMA color code for audio transformer leads. The shaded upper half is the code for an interstage transformer.

turns ratio of 3:1. The receiver tone quality and hum level may be affected by the change in transformer characteristics, but may even be improved if you use a good quality replacement. As a practical hint—don't deliberately try to change the tone quality unless the receiver owner indicates a desire for a change. He may like the tone quality and be dissatisfied with any change, no matter how much better it may sound to you.

To replace the defective transformer, first cut its leads close to the case (leaving the other ends of the leads connected in the chassis for identification), then remove it. The trans-

former may be held to the chassis by screws, bolts, or rivets, or by turned-over ears which project through holes in the chassis. Cut off rivet heads with side-cutting pliers, or drill out the rivets. Straighten turned-over ears with a heavy screwdriver.

Next, solder the leads from the new transformer into their proper places, removing each old lead when it has served its purpose as an identifier. The standard color code for a.f. transformers is shown in Fig. 8. Be sure that you follow any instructions accompanying the replacement.

Turn on the set and listen for excessive hum. Should the hum be abnormally high, see if you can rotate the new transformer to a position where the hum disappears or is at a minimum. If you find such a position, bolt the transformer to the chassis there—if not, bolt it in the most convenient location.

Bear in mind that hum might be caused by other defects—isolate the hum to the new transformer, as described elsewhere in the Course, before you consider special mounting angles or positions.

Emergency Repairs. If a replacement is not readily available for an a.f. transformer with an open winding, you can make a temporary repair by changing to impedance coupling. Shunt the open winding with a resistor and connect a coupling condenser between the plate and grid leads of the transformer. Fig. 9 shows this arrangement for a transformer with an open primary. The resistor used across an open primary should have a value of from 50,000 ohms to 100,000 ohms, while a 250,000- to 500,000-ohm resistor can be used to shunt an open secondary. A condenser of from .01 to .05 mfd., rated at 600 volts, will be a satisfactory coupling condenser.

This is usually a temporary repair.

to be used only while you are waiting for a replacement transformer. It will change the tone quality, and it may decrease the volume so much that the set will be unsatisfactory. Be careful to cut the leads going to the *defective* section (a and b for the primary, or c and d for the secondary in Fig. 9) to prevent it from "coming alive" and causing noise.

If the transformer is noisy, cut both the primary and secondary out of the circuit and use resistors in place of both windings. This, with the coupling condenser, gives ordinary resistance-capacitance coupling.

REPLACING INPUT PUSH-PULL TRANSFORMERS

Input push-pull transformers have the same troubles as interstage types—shorts, opens, and noise. If an exact duplicate is not available, you must first determine the class of operation of the output stage. Sometimes, looking up the output tubes in a tube chart will tell you this. Several tubes—type 46's, for example—are used only in class B amplifiers.

If the output tubes are triodes and are not class B types, you are usually safe in assuming that the stage is a class A amplifier. However, if the output tubes are pentodes or beam-power tubes, such as types 42, 6F6, 6V6, or 6L6, they may be operated as class A, class AB, or class B.

You can sometimes tell the type of operation from the operating voltages. Sometimes, also, class B stages are driven by a power tube. For example, a pair of 42 tubes operated from a single 42 tube acting as the driver would probably mean class B operation.

If the secondary winding is not open, you can tell the transformer class by checking the secondary resistance. A class B input transformer will have

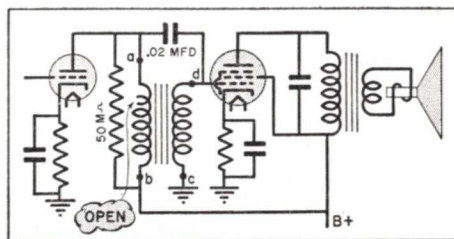

FIG. 9. How to change to resistance-capacitance coupling when there is an open transformer winding.

very low secondary resistance, usually between 100 and 300 ohms. On the other hand, a class A input transformer may have a secondary resistance of from 1500 to 3000 ohms.

► Any high-grade input push-pull transformer which fits the space available will make a satisfactory replacement in a class A output stage. These transformers usually have ratings of 3 to 1.

On the other hand, a duplicate input transformer is necessary for a class AB or B stage. These transformers are designed to work from a particular driver tube into the grid circuit of particular class AB or B stages.

► Hum pickup caused by the transformer's being too near the power transformer, speaker field, or filter choke may make it necessary occasionally to change the position of the replacement.

► Temporary repairs can be made if the primary of an input push-pull transformer opens. Simply shunt the open primary with a .5-watt resistor of between 50,000 and 100,000 ohms, and connect a .01- to .05-mfd., 600-volt condenser from the plate lead of the transformer to either (not to each) of the grid leads. The secondary will then act as an auto-transformer and will deliver equal signal voltages, 180° out of phase, to each push-pull grid.

Phase Inverters. If your customer is interested in improved tone quality

(at additional expense) and the output stage is class A, you may suggest using a phase inverter stage in place of the original input push-pull transformer.

The before-and-after circuits for making this conversion are shown in Figs. 10A and 10B. Since the phase inverter is self-balancing, no adjustments should be necessary. The phase inverter tube (a dual triode in a single envelope) must operate at the same filament potential as the original tube VT₁.

OUTPUT TRANSFORMERS

The primaries of output transformers frequently burn out. While an exact duplicate replacement is preferable, universal output transformers will give very good results in ordinary class A output stages. These transformers are equipped with tapped primaries and secondaries, which make it possible to match either single or push-pull output tubes to any of the common voice coil impedances.

While complete instructions are packed with each transformer, the general procedure is to connect the primary first. For push-pull operation, the two outside leads go to the plates and the center tap to B+. For a single output tube, follow the instructions. In some cases, the center tap is not used, and one of the outside primary leads goes to B+ and the other to the plate of the tube. In other cases, half of the primary is used.

Then, solder the correct secondary leads to the points from which the original secondary leads were removed. If you know the voice coil impedance, the instructions will tell you which two of the secondary leads can be used. If you don't, you can calculate the voice coil impedance roughly by measuring its d.c. resistance with a low-range ohmmeter. The impedance will be about 1.5 times the d.c. resistance. Modern speakers usually have voice

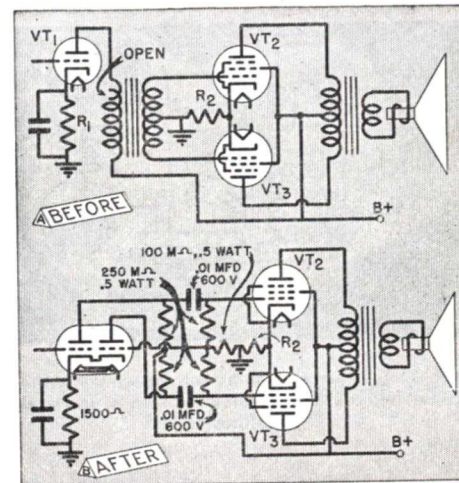

FIG. 10. Substituting phase inversion for an input push-pull transformer.

coil impedances of 6 to 8 ohms, but others range from 2 to 15 ohms.

A slight mismatch is unimportant. However, a large mismatch will decrease the volume to some extent and will cause a noticeable change in response (the high notes will be either too weak or too strong). If the reproduction does not sound normal (*with the receiver in its cabinet*), try different taps, listening for best response.

If the set has pentode or beam-power output tubes, *don't disconnect the secondary leads while the set is turned on*. Removing the load this way can damage the output tube.

Of course, turning off the set each time you try another secondary tap makes it hard to compare results, since by the time you've connected a tap, you'll probably have forgotten how the set sounded when the previous tap was used. To avoid this difficulty, some servicemen use a test output transformer and "shorting" switch combinations like that shown in Fig. 11. This switch will not break contact with one point before making contact with another, so there will always be a load on the transformer. Clips are used to connect to the output tubes and to the

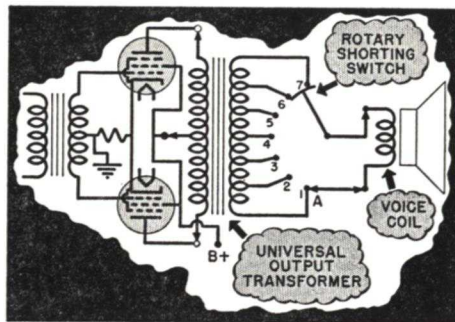

FIG. 11. An arrangement for determining the proper impedance-matching taps on a universal transformer.

voice coil. The lead A also has a clip, and is fastened to one of the transformer terminals. The switch then can be rotated to various taps and responses can be compared rapidly. If optimum results are not obtained, lead "A" can be clipped to another terminal and a new combination tried. Thus, starting on 1, we can compare the outputs using terminals 1-2, 1-3, 1-4, 1-5, etc. Then, with A on 2, we can compare the outputs of 2-3, 2-4, 2-5, etc. (The set should be turned off while A is being moved, and the switch should not be set on the same terminal as A, to avoid removing the load.) The impedance of the taps which give the best output can be found on the chart furnished with the transformer. Now, knowing the

R.F. and I.F. Transformers

I.F. windings require more frequent replacement than r.f. coils, but their replacement is usually simpler. Both have opens, noise, and lowered Q as their troubles. Short circuits are not so common, but do occur in multi-layer windings. Let's run through the problems for both transformer types.

R.F. TRANSFORMERS

In any receiver, the r.f. (tuning)

proper impedance to use, you can install a transformer having this rating, or can find the proper terminals to use on another universal transformer.

► A universal transformer should not be used in high-fidelity receivers, p.a. systems, high-power circuits (here the types of output tubes are a clue), or if class B operation is used. For such circuits, order a replacement (if you can't get a duplicate) by stating the type numbers of the output tubes, the model number and make of the loudspeaker, and its d.c. voice coil resistance.

► In some receivers, the secondary of the output transformer is tapped to provide inverse feedback. Use an exact duplicate here if possible. Should howling occur when a duplicate is installed, the feedback is causing regeneration rather than degeneration; reverse the connections to the primary of the output transformer. This will reverse the phase of the voltage across the secondary.

If such a transformer must be replaced by a universal transformer, disconnect both ends of the lead which ran to the tap on the old transformer. If the lead is left connected in the circuit, even though it is not connected to the new transformer, it may provide a feedback path and so cause instability and howling.

coils must have equal inductance and distributed capacity values so that they will track when they are used with identical ganged condensers. This means the tuned secondaries must be held to close tolerance values, so most servicemen use exact duplicate replacement coils when anything is wrong with the tuning winding.

If a duplicate is not available, you can: 1, have one wound by a coil manu-

facturing company (your supply house will forward your order to one if you do not wish to order direct); 2, get a universal coil with an adjustable inductance; or 3, replace all the r.f. coils with a matched set. Let's consider these steps in order.

Case 1. In ordering coils, give the following information:

1. Name and model of radio.
2. Number of chassis and any chassis identification such as a series or code number.
3. Name of coil or of circuit in which it is used (antenna, 1st or 2nd r.f.).

This is usually enough information if the receiver is a popular brand, as coil winding firms know the specifications on these coils and can wind a du-

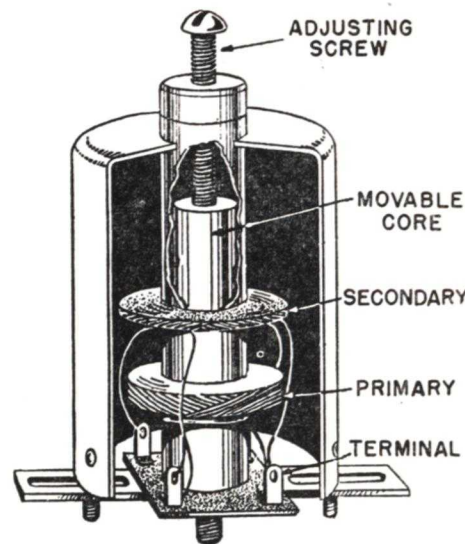

FIG. 12. A universal r.f. transformer.

plicate. However, if the coil is removed from an "orphan" or unidentified chassis, send a schematic diagram of the section of the circuit in which it was used. If requested, send in the defective coil as a sample. (When ordering from a distance, it is a good idea to

send the defective coil in as a model, whether requested or not.) If any lugs, leads, or mounting brackets are missing, make a note of their locations. If a shield is used, give its dimensions.

If the coil is one of an identical series of coils, such as are found in a t.r.f. set, a good coil can be sent in as a sample, but be sure to request that it be returned to you.

Case 2. The inductance of a universal coil can be varied over a wide range by an adjusting screw, so if its distributed capacity is not too far off, a universal coil can be made to track reasonably well. Fig. 12 shows a cut-away view of such a coil.

It's easy to adjust a universal antenna or r.f. coil in a t.r.f. receiver. Use a condenser of about 200 mmfd. (.0002 mfd.) as a dummy antenna; connect it between the hot side of a signal generator and the antenna connection of the receiver. Connect an output meter to the receiver, tune the signal generator and the receiver to 600 kc., and rotate the adjusting screw of the coil until you obtain maximum output. Next, tune the receiver and signal generator to 1400 kc. and align the circuits by adjusting the trimmers on the gang for maximum output. This may throw the adjustment at 600 kc. off somewhat, so retune the signal generator and receiver to this frequency and reset the screw for maximum output. Continued adjustment of the 600-kc. and 1400-kc. adjustments usually will give reasonable tracking over the band. However, if the responses are very unequal, or adjusting one throws the other completely off, the distributed capacity of the universal coil winding is widely different from that of the other coils; you should then use an exact duplicate coil or a matched set of coils.

► A slightly different procedure must be followed when you replace an antenna or r.f. coil on a superheterodyne,

since the 600-kc. and 1400-kc. receiver dial settings depend upon the receiver oscillator, rather than upon the coil being replaced. First install the new coil, then adjust the oscillator high-frequency trimmer and the low-frequency padder, if one is used, so that the receiver tracks its dial. Next, adjust the new coil inductance at 600 kc. and its trimmer at 1400 kc. for maximum output. Repeat the low- and high-frequency adjustments for the new coil just as for a t.r.f. set. Do not adjust any of the other trimmers on the gang at this time—only the one for the new coil. Complete realignment can be made after the inductance of the replacement coil is satisfactory.

Case 3. When you have an a.c.-d.c. t.r.f. set using a single stage of r.f., in which either the antenna or r.f. coil is defective, simply order a matched antenna coil and an r.f. coil. Specify that they are to be used in an a.c.-d.c. midset. Get shielded coils if the originals were shielded. In most cases shields are not used, the antenna coil being mounted above the chassis and the r.f. coil under the chassis. The instructions which come with the coils will facilitate their installation, but of course you should identify each lead on the old coils before unsoldering them. Fig. 13 shows a typical pair of replacement coils.

Defective Primaries. The foregoing procedures are necessary if the secondary or tuned winding is defective. However, the secondaries seldom fail; it is the primaries, which carry appreciable amounts of plate current, that usually open up. The primaries of antenna coils (these are also called r.f. coils) are sometimes burned to a crisp by lightning or by a customer's carelessly plugging the aerial and ground leads into a lower line outlet rather than an antenna outlet.

Most servicemen replace the entire

coil if the primary is defective, particularly when a replacement is easy to obtain. However, the inductance of the primary is not critical, so it is possible to use a replacement primary winding which can be slipped on the coil form and wired in the circuit to replace the original.

Since r.f. coils vary in physical size you should have an assortment of these windings on hand if you intend to use them. Both low- and high-impedance types are available, but most modern radios use the high-impedance types.

The replacement primary is slipped over the secondary as shown in Fig. 14. Be sure to follow the manufacturer's instructions carefully, for the position and direction of the winding are important. If it is necessary to disconnect the transformer to get the primary on, be sure to make a connection sketch.

OSCILLATOR COILS

An open primary is the usual defect of an oscillator coil. It is best to install an exact duplicate rather than a

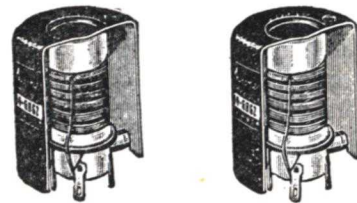

FIG. 13. A cut-away view of a set of shielded, matched r.f. transformers. These are also available unshielded.

new primary, because the primary controls the amount of feedback.

If necessary, the coil can be repaired by one of the firms specializing in this business. If you send a coil off to be repaired, include a schematic diagram of the circuit in which it is used, give the make and model number of the receiver, the intermediate frequency, the type number of the oscillator tube, and state if the oscillator section of the con-

denser gang has specially shaped plates.

Be certain that you draw and keep a diagram of the exact connections to the coil lugs—so you'll have no trouble in making the new installation.

Universal oscillator coils are available, but their installation and adjustment is quite a problem, particularly if the padder adjustment has been disturbed. If you get a universal coil, be sure to follow the detailed instructions furnished by its manufacturer.

Multi-Band Coils. When the receiver has several wave bands and uses a tapped coil or multiple windings on the same form, either an exact duplicate or a rewinding job is necessary. Matched sets of coils with taps for the police band are available for a.c.-d.c. receivers, but these are almost the only exceptions.

I.F. TRANSFORMERS

The i.f. transformer assembly includes the coils and their tuning condensers. Occasionally the trimmers will short or become leaky, or a high-resistance joint will develop. Generally, though, the trouble is an open coil, which you can repair by installing either a replacement coil or a complete transformer assembly. If a new transformer is available, use it in preference to new windings, since far less time will be spent in making the replacement.

Any large coil manufacturer can furnish either duplicate or satisfactory universal replacements. Sometimes, mounting holes for the new shield will have to be drilled in the chassis. When you order a replacement transformer, state the make and model number of the receiver, the i.f., and the position occupied by the transformer in the circuit. For example, if two i.f. transformers are used they are spoken of as the first (or input) i.f. transformer and as

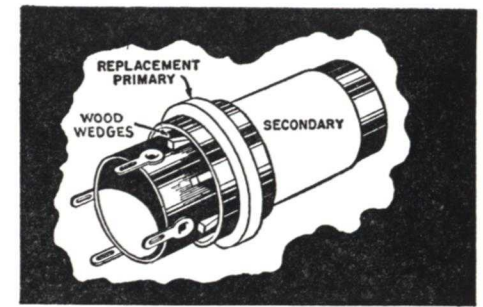

FIG. 14. How a replacement primary winding is installed.

the second (or output) i.f. transformer. If three i.f. transformers are used, the first is called the input i.f. transformer, the second is called the inter-stage i.f. transformer, and the third is called the output i.f. transformer. It is very important to get transformers which are designed to work with the number of i.f. stages used. Transformers designed for a single i.f. stage have very high gain, and if they are placed in a set using two stages of i.f. amplification, the amplifier will be unstable and may oscillate.

Try to get a replacement with the same physical dimensions—give the size of the transformer shield and the mounting centers.

The leads on the replacement transformer may have a different color code than the original transformer leads had. Replacement i.f. transformers use the color code shown in Fig. 15 unless otherwise specified.

The blue (plate) lead and the green (diode or control grid) lead should be kept as far as possible from each other, and away from other grid and plate leads. The position of the original leads is usually a reasonable guide, but if the new transformer has a higher gain than the original, it may be necessary to separate the leads more to prevent oscillation.

In general, the blue and green leads should be as short as possible. The

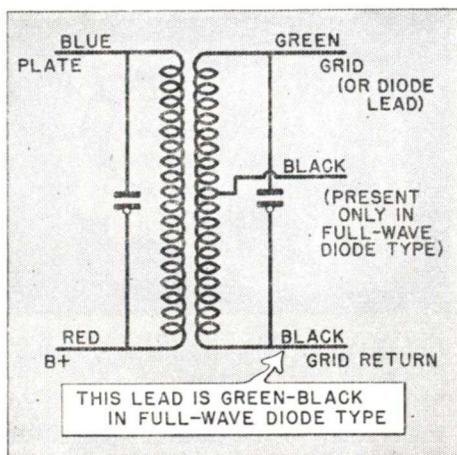

FIG. 15. RMA color code for i.f. transformer leads.

length and routing of the red (B+) lead is ordinarily unimportant. The length and route of the black lead is important only in output transformers; in them, this lead carries i.f. to the diode load and is quite "hot," so should be kept short.

► If you can't get a replacement i.f. transformer which will fit on the chassis, install replacement coils—preferably exact duplicates. Again, your order must identify the receiver by make and model number and also identify the i.f. transformer. If an exact duplicate is not available, order a replacement designed to operate at the intermediate frequency of the receiver and equal or close to the original in physical dimensions. Typical replacements are shown in Fig. 16.

► The spacing between the primary and secondary coils is important, but is usually factory-adjusted. Should you get a set of coils with adjustable spacing, however, measure the distance between the original coils before removing them, and use the same spacing on

the replacements. This will give average satisfactory results.

An exact adjustment can be made by getting a response curve for the transformer with a c.r.o. and a frequency-modulated (wobulated) oscillator in the manner you learned earlier in your Course. If the coils are somewhat overcoupled the curve will be flat; if they are very much overcoupled it will be double-humped. If the coils are undercoupled the curve will be "low." Overcoupling causes poor selectivity; undercoupling results in poor sensitivity. You should adjust the spacing of an ordinary i.f. transformer so that the response curve just starts to flatten at resonance. An adjustable band-expanding transformer should have no flattening of the response curve in the sharp or selective position, but in the broad or "fidelity" position the curve should have a flat top or even a double-

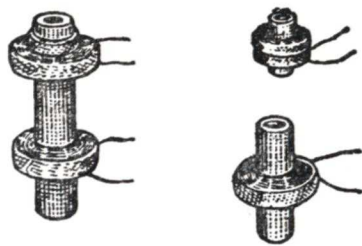

FIG. 16. Typical replacement i.f. windings.

hump. High-fidelity transformers (which are usually factory-adjusted) will be overcoupled and should have a broad flat-top or double-hump characteristic.

Once you've found the right spacing, cement the coils in place with coil dope.

Some i.f. transformers have three windings, for band-pass operation. Use a duplicate instead of a universal replacement for these.

Replacing Condensers

You may have to replace all kinds of condensers—even tuning condenser gangs. However, you will usually carry only an assortment of paper and electrolytic types, and perhaps a few fixed mica condensers in stock. Let's take up condenser replacements according to type.

PAPER CONDENSERS

The most important ratings for any condenser are the capacity and the working voltage. The rating of the original part usually can be found from the schematic diagram or from the condenser label, but an exact duplicate replacement is seldom needed for a defective paper condenser. A wide variation in capacity is usually permissible.

If you don't know the original capacity, use .01 mfd. to .1 mfd. for r.f. and i.f. by-passing, .25 mfd. to 1 mfd. for a.f. by-passing, .00025 mfd. for grid leak detectors, .002 mfd. to .05 mfd. for a.f. coupling condensers, and .001 mfd. to .05 mfd. for buffer condensers. This gives a clue to the sizes you should stock. A few each of the .01, .05, .1, .25, and .5-mfd. sizes will be adequate for practically all by-pass and audio coupling purposes.

A more important factor is the condenser working voltage rating, *which should always be greater than the voltage across the terminals to which the condenser is connected*. Many servicemen never use a paper condenser with less than a 600-volt rating (space permitting) even if the condenser is to be used in a low-voltage circuit. It costs only a few cents more and is excellent insurance against a call back. Buffer condensers in vibrator power supplies should be rated at 1600 volts or more. Filter condensers of the paper type (very rare today) should have a 600-

volt to 1000-volt rating.

Sometimes one end of a tubular paper condenser will have a black ring on it and be marked "outside foil" or "ground." The foil connected to the lead at this end of the condenser is the final outside layer and surrounds the rest of the condenser. If a condenser goes either directly or through a low-impedance path to ground, this ground connection should be made to the outside foil end of the condenser—the outside foil then acts as a grounded shield and prevents undesirable coupling between the condenser and other circuits. In most well-designed receivers, however, it won't make any difference which end of a paper condenser is grounded. If the condenser is used for coupling (neither end grounded), ignore the outside foil marking.

ELECTROLYTIC CONDENSERS

Electrolytic condensers often prove puzzling to newcomers in the service business. When replacements are to be made, many questions about capacity, working voltage, and types come up.

Let's consider capacity first. A replacement should not be much below the capacity of the original, but can be much higher. For example, a 10-mfd. output filter condenser should not be replaced by one smaller than 8 mfd., but a much larger condenser can be used and will give better filtering. However, do not replace an input filter condenser with one of more than twice the capacity of the original, for the peak current through the rectifier tube may increase to the point where the tube will be damaged. This is particularly true of a.c.-d.c. sets.

In replacing electrolytic by-pass condensers, never use a capacity lower than the original; a larger capacity will give better results. In replacing

condensers used across the filament strings of three-way receivers, stick to the original capacity if possible.

Here is a good rule to remember about working voltage. *The working voltage of the replacement must be at least as high as the original*; if it is higher there will be less chance that the new condenser will break down. If you are in doubt about the voltage applied to the condenser, check it with a d.c. voltmeter. When the set is first turned on, the voltage may be considerably higher than when the tubes start drawing current. It is this initial high voltage that the condenser must withstand. A working voltage of 150 volts is standard for filter condensers in a.c.-d.c. sets (voltage doublers use 250 volts), while 450 volts is standard for a.c. receivers. C bias by-pass condensers are usually rated at 25 or 50 volts.

Dry electrolytics usually—but not always—can be substituted for wet electrolytics. Remember the fundamental difference between the two. The dielectric of wet electrolytics can be broken down by an overload, but when the overload is reduced the dielectric film will reform. If dry electrolytics are overloaded for any length of time, their dielectric film breaks down *permanently* and the condenser must be discarded. In some sets using wet electrolytics, the initial starting surge breaks down the dielectric film each time the set is turned on. If you want to substitute dries, be sure to check this starting voltage. If it exceeds the working voltage of the condensers, either install wet electrolytics, or try a 50,000-ohm, 5- or 10-watt bleeder resistor across the output filter condenser. The resistor will draw current as soon as the rectifier tube starts passing current and usually will reduce the starting voltage to a safe level. Be sure to measure the voltage again after installing

the bleeder, however, to be certain it does not lower operating voltages too much.

The type of can or container used for electrolytic condensers has nothing to do with replacements. For example, a condenser in an aluminum can may be replaced by a tubular paper type electrolytic with similar ratings.

► If there are a number of condensers in a case and only one is bad, you can connect a single-section replacement unit outside the case in the place of the defective section. However, it is best to replace them all, since the others will not last as long as the new one. Not only must the replacement contain the correct number of con-

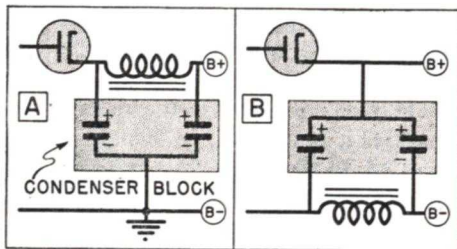

FIG. 17. Two styles of filter condenser blocks. These are NOT interchangeable, so be sure you get the proper replacement.

densers, but also their leads must be arranged so that they can be properly wired into the circuit. As an example, look at Figs. 17A and 17B. Each condenser block contains the same condensers and each has three leads. Yet the blocks could not be interchanged—the block in Fig. 17A has a *common negative* lead for both condensers, while the block in Fig. 17B has a *common positive* lead for both condensers. If any of the leads in a block are common to two or more condensers, say so when you order a replacement. Two separate condensers, or two condensers in a block with separate positive and negative leads, could be used to replace the condensers in Figs. 17A and B.

MICA CONDENSERS

Mica condensers rarely go bad; when one does, it is best to use a replacement of the same capacity. Because different color codes are often used on micas, it is usually easiest to identify the proper size from the wiring diagram. If you have no service information, examine the original. You may find the capacity value is stamped on the condenser, or it may be marked according to the standard color code (see Fig. 18). Remember, *private* color codes are sometimes used, so if you come out to some unreasonable capacity value, the marking is probably *not* the standard code.

GANG TUNING CONDENSERS

In modern receivers the tuning condenser gang seldom becomes so defective it cannot be repaired. Even badly bent plates usually can be straightened with a thin putty knife. However, if they are beyond repair, the shaft is bent, or the bearings are damaged, a new gang—an exact duplicate—should be installed. Unless you order from the set manufacturer, remove the old gang and send it with your order to make certain you get the correct replacement. Be sure to give the make and model number of the receiver.

RMA COLOR CODE FOR MICA CONDENSERS			
COLOR A is first figure of capacitance.	COLOR B is second figure.	COLOR C is third figure.	COLOR D is number of zeros after third figure.
COLOR E is tolerance.	COLOR F is working voltage.		
Capacitance in MMFD for condensers smaller than .01 mfd, capacitance in MFD for larger condensers. Arrow or lettering usually shows right direction for reading dots.			
COLOR	FIGURE	TOLERANCE	WORKING VOLTAGE
BLACK	0	—	—
BROWN	1	1%	100 V.
RED	2	2%	200 V.
ORANGE	3	3%	300 V.
YELLOW	4	4%	400 V.
GREEN	5	5%	500 V.
BLUE	6	6%	600 V.
VIOLET	7	7%	700 V.
GRAY	8	8%	800 V.
WHITE	9	9%	900 V.
GOLD	—	5%	1000 V.
SILVER	—	10%	2000 V.
NONE	—	20%	500 V.
		case color	

FIG. 18. The RMA color code for mica condensers.

The plates of older condensers were often set in white metal castings. This metal may warp, throwing the condenser out of line and causing the rotor and stator plates to scrape against each other. Don't try to bend the plates, unless no replacement is available, as the casting will continue to warp and the trouble will reappear in a short time.

Replacing Resistors

Resistors fall into several classifications: fixed, semi-variable, and variable types. They may have carbon, a metallic deposit, or resistance wire as the resistive element. Let's take up each type in turn.

FIXED RESISTORS

You're usually safe in suspecting excess current as the reason for a metalized or carbon fixed resistor's going

bad, particularly if the resistor has a burned or charred appearance. (Wire-wound resistors rarely burn out—electrolysis at the junction of the terminal lug and the resistance wire is the usual trouble.) Look carefully for the cause of this excess current before installing a new resistor. A check from the low potential end of the resistor to the chassis with an ohmmeter will show whether a broken-down condenser or

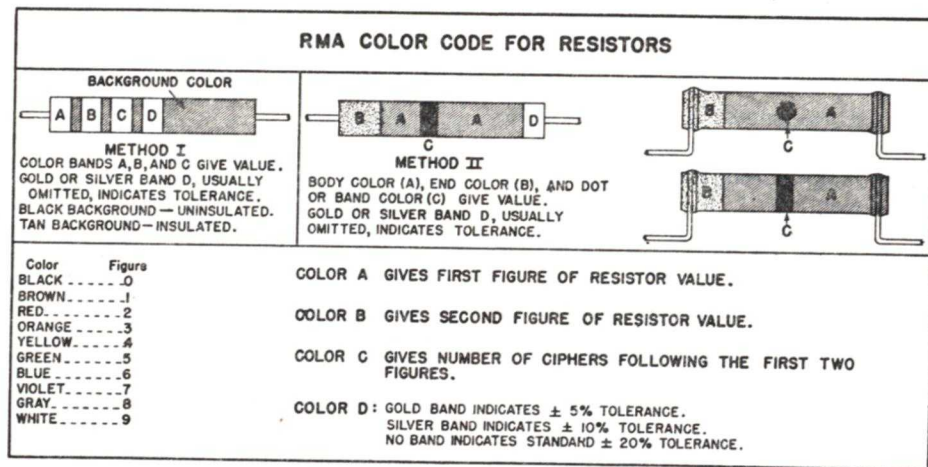

FIG. 19. The RMA color code for resistors.

some other short burned out the resistor. If the resistor is not changed in appearance and no short can be found, the element is probably cracked.

After you've repaired the short (or made sure there is none), determine the proper size for the replacement.

Resistance values are not critical and a variation of 20% is of little importance. You can find the value of the original resistor from the schematic diagram, or from the color code markings (if it follows the standard code). The color code for resistors is shown in Fig. 19.

The circuit in Fig. 20 shows some typical resistor value ranges. If you can't determine the resistance of the burned-out resistor, install one that is shown by this figure to be appropriate for the circuit involved. If the set works satisfactorily and the voltages seem to be normal, leave the resistor in—otherwise, experiment with different values until you get the results you want.

► Always use a replacement resistor with a wattage rating equal to or higher than that of the original—never lower. Otherwise, the replacement will burn out. You can use the physical size of the resistor as a guide if the re-

placement is the same type (carbon, metallized, or wire-wound) as the original. The replacement should be the same physical size, or larger.

If carbon resistors used as bleeders or voltage dividers are defective, replace them with 10- or 20-watt wire-wound types.

When sections of a candohm unit fail, it is generally best to replace the entire unit with a duplicate or with individual wire-wound units. Don't use the lugs on the candohm as anchor points for individual resistors, because the defective unit may "come alive."

Your stock of resistors should include a kit of carbon or metallized resistors in the $\frac{1}{2}$ -, 1-, and 2-watt sizes. You will usually find that values of 200, 300, 1000, 5000, 25,000, 50,000, 100,000, 250,000, and 500,000 ohms are used most. Then, you can add a kit of wire-wound 10- and 20-watt types. The most used sizes of these depend on the kinds of radios you service most, and they can be learned best from experience.

► Most wire-wound voltage dividers have fixed, predetermined values. If a duplicate divider cannot be obtained and the section values cannot be determined from the service data, install

a 25,000- to 50,000-ohm, 50-watt semi-variable unit and adjust it to give the proper voltages. Then, measure the sections and use fixed resistors as replacements for them.

► Some of the new molded resistors look like the small mica condensers. These resistors are ordinarily black, marked with three colored dots. Read these dots in the same order as you would those on a three-dot condenser; they then have the same meaning as the body, end, and dot colors respectively, on regular carbon resistors.

There are also condensers shaped like resistors. The condenser values are indicated by bands of color. Two groups of bands may be used, with the bands in each group being the same width, and the groups of bands being different in width. The bands of greater

width indicate the significant figures of the capacity, while the bands of smaller size indicate the number of ciphers, the tolerance, and the voltage rating respectively.

VARIABLE RESISTORS

Volume and tone controls are the most important variable resistors. Exact duplicate controls are available and are the simplest to install. Some special dual control units can be replaced only by exact duplicates. However, a kit of universal sizes will permit replacement of most controls; sooner or later you will probably stock such a kit.

The physical size of a volume or tone control will not matter as long as it is not too large for the space provided. However, there are several types of

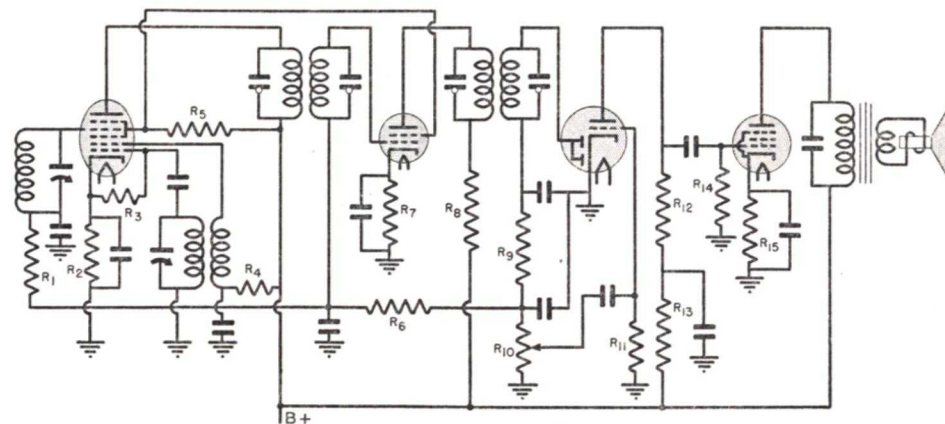

FIG. 20. This circuit shows the locations of most of the resistors used in modern radio receivers. (The diagram is incomplete otherwise.) Here are typical values used:

- R₁—a.v.c. decoupler—50,000 to 250,000 ω (100,000 most common)
- R₂—1st det. bias resistor—200 to 300 ω
- R₃—osc. grid resistor—50,000 ω for a.c., 100,000-200,000 ω for battery tubes
- R₄—osc. plate resistor—20,000 ω
- R₅—screen dropping res.—50,000 ω if no bleeder
- R₆—a.v.c. decoupler—500,000 ω to 2 megs. (1 meg. most common)
- R₇—i.f. bias—200-600 ω (usually 300 ω)
- R₈—i.f. plate decoupler—1,000 to 10,000 ω (usually 2000 or 5000 ω)
- R₉—i.f. filter—50,000 ω
- R₁₀—diode load—50,000 to 500,000 ω (100,000 ω most common)
- R₁₁—1st a.f. grid—500,000 if biased; 10 to 20 megs. if convection biased
- R₁₂—R-C plate res.—50,000 to 250,000 (100,000 most common)
- R₁₃—plate decoupler—5000 to 50,000 (10,000 or 20,000 most common)
- R₁₄—R-C grid res.—100,000 to 500,000 (250,000 most common)
- R₁₅—power tube bias—150 to 600 ω (depends on tube, and whether bias is for single or push-pull tubes)

shafts, and if the wrong one is used the knob may not fit. Most shafts which are not exact duplicates are considerably longer than necessary and must be cut to the right length with a hacksaw.

The original control may have been equipped with an ON-OFF switch. If so, a switch can be attached to the back of a universal control by following the manufacturer's instructions. Consult a control guide book if the original switch is a special type, such as may be found in battery sets; you may have to use a duplicate control.

The electrical size of a volume control depends on the circuit in which it is used. Some representative circuits are shown in Fig. 21. (Volume control guides show many more.) These guides will also prove helpful if you can't determine resistance values from the schematic diagram or the original control. Actually, the resistance value is seldom critical.

Of the three types of connections commonly used today, the combination antenna-C bias control (Fig. 21A) may have any value between 10,000 and 25,000 ohms; the a.f. grid control (Fig. 21C) may be between 250,000 ohms and 2 megohms; and the diode load type (Fig. 21E) may be from 50,000 to 250,000 ohms.

More important than the resistance value is the control taper—the manner in which the resistance varies with the shaft rotation. You don't have to worry about this, however; just name or sketch the circuit in which the control is used and your supplier can furnish the proper replacement. (Your kit of universal types will have a guide book showing the proper types.)

Some controls have taps for automatic bass compensation circuits. Be sure the replacement has similar taps.

► Tone controls are ordered and re-

placed the same as volume controls. Again, a guide book will prove helpful.

► Before removing an old control, always draw a connection diagram so you'll have no trouble wiring up the new control. When the old control is removed, measure the distance from the end of the shaft to the threads on the bushing. If necessary, cut the new control shaft to the same length with a hacksaw. Hold the end of the shaft in a vise while cutting it.

When one terminal of a control must be connected to the set chassis, you will sometimes find that the connection was made internally in the original control. An *exact duplicate* replacement will have a similar connection, but a *universal* replacement will not. In this last case, you have to run a wire from the proper terminal lug to the chassis, in addition to making the other connections.

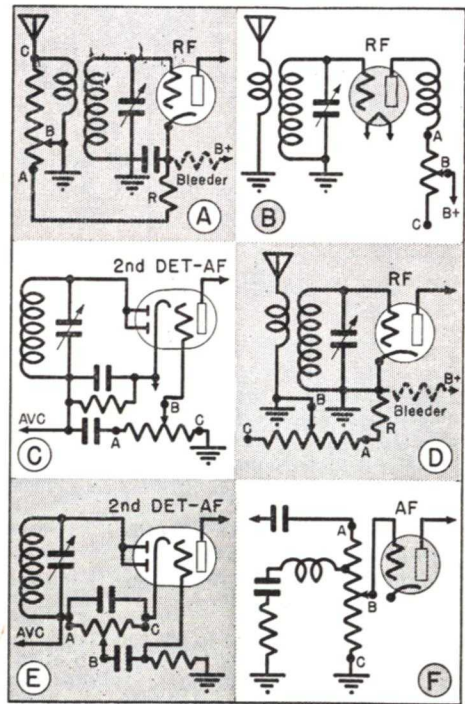

FIG. 21. Typical volume control connections.

Replacing Loudspeakers

Speaker repairs generally are made by the manufacturer or by firms specializing in this service, although occasionally you may find it profitable to replace a cone-voice coil assembly or a field coil yourself. Very often, particularly in small sets, the cheapest course is to buy a new speaker. Let's see just how you should go about ordering new parts, repairs, or new speakers, and how you should install replacements.

Replacement Cones. If you are going to have a cone replaced by the set manufacturer or by a firm specializing in this service, send in the entire speaker. It will come back with the proper cone installed.

If you decide to replace the cone yourself and can get the old cone out of the speaker intact, send it to the set manufacturer or to a firm manufacturing cones and request a duplicate. Include the make and model number of the receiver with your order.

If the old cone is completely torn up or missing, or if you are servicing some private brand or orphan* receiver, you can send the speaker to a cone manufacturer and have an acceptable cone installed. Should you prefer to install the cone yourself, and don't know the name of the set manufacturer, examine the speaker carefully to see whether you can determine the name of the speaker manufacturer and the model designation of the speaker.

If you can't find this information, specify the diameter of the cone, the diameter of the voice coil, and the im-

pedance of the voice coil when you order a replacement from a cone manufacturer. Be sure to state whether the diameter is that of the cone opening or that of the speaker frame rim. You should specify also the depth of the cone housing from the front pole piece to the front edge of the housing. It is advisable to make a drawing showing just what measurements you are giving, to help the manufacturer determine the right size for the cone.

Field Replacements. What we've said about cone replacements applies also to the speaker field. You can return the original speaker to the set manufacturer or send it to a firm specializing in replacements, allowing them to install the proper type for you. If you want to do the work yourself, be certain that you specify the make and model number of the set, as well as any other numbers which may appear on the speaker itself.

If an exact duplicate replacement is unavailable, you must give the resistance of the field and its physical dimensions (length, and inside and outside diameter). Universal replacement speaker fields are available which have two windings; the resistance of these can be adjusted by making series or parallel connections, but the range of the adjustment is limited, so the field selected must be near the right size in the beginning.

You may wonder how you can give the field resistance when the original field is burned out. A service manual or a speaker field replacement guide usually will tell you what the resistance should be. If these sources fail, you can make a reasonable estimate of the resistance from the way the speaker is used, or you can find it by a resistance substitution method.

*A private brand set is manufactured for department stores, chain stores, or small retail outlets. An orphan is one which does not have the manufacturer's name on the set, or one of which the manufacturer is out of business.

► For example, you know that usually the speaker field of an a.c.-d.c. receiver either is connected across the output of the rectifier, as shown by coil L_1 in Fig. 22A, or is connected to a single diode as in Fig. 22B. In either case, the field value will be 2500 to 3000 ohms, and any value in this range will prove satisfactory.

Should the speaker be used as a choke in an a.c.-d.c. receiver, in the position indicated for coil L_2 in Fig. 22A, the resistance is low—usually 300 to 400 ohms.

► In the standard a.c. receiver, the speaker field is usually used as a choke coil, illustrated as coil L_1 in Fig. 23. If this coil is burned out, a resistance

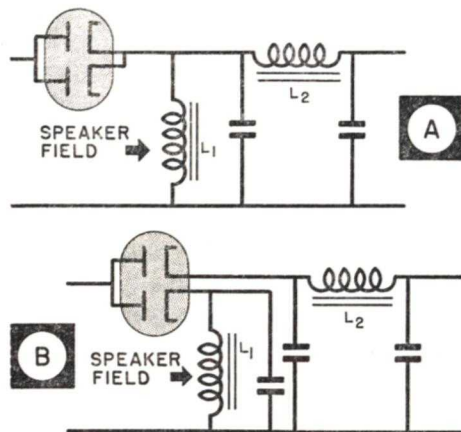

FIG. 22. Two methods of connecting speaker fields which are used in universal a.c.-d.c. sets.

substitution method will let you find its approximate resistance.

First, check the set to be certain that no short circuits have passed excess current through the field and caused the burnout. Repair any shorts that you find. Next, connect a resistor in place of the field as shown in Fig. 24. Use a 5000-ohm variable resistor, rated at 20 watts or more, which has one or more sliding taps. First move the slider to the end of the resistor, placing all the

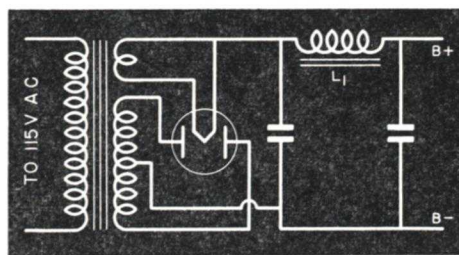

FIG. 23. The speaker field is used here as the choke.

resistance in the circuit. Then turn on the set and measure the voltage between B+ and B-. Compare this voltage with the voltage given in the service diagram or with the normal voltages usually applied to the output tubes. If the measured voltage is too low, decrease the value of the resistor by moving the tap (turn off the set before doing this). Experiment with the tap position until the correct B supply voltage is secured, then disconnect the resistor and measure the resistance of the section finally used with an ohmmeter. This is approximately the resistance of the field.

A speaker in the negative side of the circuit may have a tap for bias connections, as shown in Fig. 25. If an open is found between the tap and ground, in the bias section, it is frequently possible to replace this section of the field with a resistor, allowing the remainder of the field to act as a choke coil.

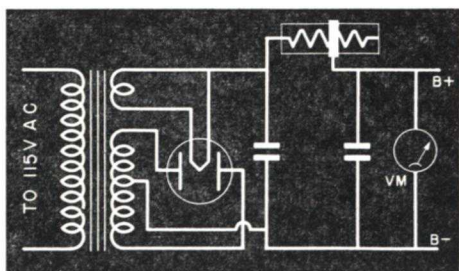

FIG. 24. Finding the resistance of a burned-out field by resistance substitution.

Since the tapped section of the field usually has a resistance of only 300 ohms or so, a 500-ohm, 10-watt resistor with a slider tap can be used. (See Fig. 25.) To adjust the resistor, first put all the resistance in the circuit; then, with the receiver turned on, gradually reduce the resistance until the proper bias voltage appears across it.

If the open is in the main section (L), a replacement is necessary.

ORDERING AND INSTALLING REPLACEMENT SPEAKERS

There is, of course, no particular problem involved in ordering or installing an exact duplicate speaker. Simply order the replacement from the set manufacturer or distributor, giving the model number of the set and the make and model numbers of the speaker.

Some set manufacturers sell new speakers on a "trade-in" basis. When you send in the old speaker to get a new one on this plan, give the model number of the receiver. Any other information the manufacturer needs he can get from the old speaker.

► If you want to use a speaker which is not an exact duplicate, you must be sure the voice coil impedance, the speaker field resistance, and the physical size of new speaker are acceptable. For instance, the new speaker should not have a cone diameter larger than the opening in the baffle of the radio cabinet—if it does, it will be necessary to cut a larger opening in the cabinet, which may not be practical. (Of course if the speaker is smaller, you can always mount it on a board which has an opening of the proper size and fasten this board over the original baffle opening.) And when you order a speaker for a table model cabinet, you must be sure to get one of such size or shape that it will fit into the cabinet with the radio.

As you have learned, the voice coil impedance can be found by measuring the voice coil resistance with an ohmmeter, then multiplying this resistance by 1.5. This is just an approximation, and it is possible for some mismatch to occur. Therefore, if you're not positive that the voice coil impedance of the new speaker is the same as that of the old one, replace the output transformer as well as the speaker. You can usually buy an output transformer with the speaker which will match it to the output tubes used. Specify the make and model number of the speaker and the number and types of output

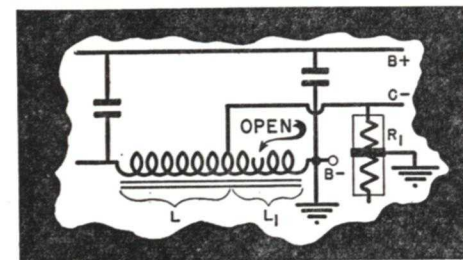

FIG. 25 A tapped speaker field.

tubes when you order the transformer.

You might use a universal output transformer, adjusting it in the manner you learned earlier in this lesson.

Replacing Magnetic Speakers.

Since magnetic speakers are far inferior in performance to p.m. dynamics, many servicemen use p.m. replacements for them. Usually, magnetic speakers are found in midgets, where space limitations are important. However, p.m. type speakers are made with diameters as small as 2 inches, and usually take no more space than the equivalent magnetic speaker.

Although a matching transformer is necessary with the p.m. speaker, those used with little speakers are generally small enough to fit into even a midget receiver without trouble. When you order your p.m. speaker, specify that it be equipped with an output trans-

former which will match it to the power tube used.

Replacing P.M. Speakers. You should always replace a defective p.m. speaker with another p.m., to avoid having to energize a field. You have to consider only the size of the replacement and the voice coil impedance. A new output transformer is necessary if the voice coil impedance differs from the original.

Replacing Electrodynamc Speakers. Should you wish to replace an electrodynamic speaker with a p.m. speaker, you must match the voice coil impedance of the p.m. unit to the set output (using a new transformer if necessary) and also make whatever set adjustments are necessary to compensate for the loss of the field coil.

If the field of the original speaker was in parallel with the voltage source (like L_1 in Figs. 22A and 22B), as it is in many a.c.-d.c. receivers, just remove the original field connections. If

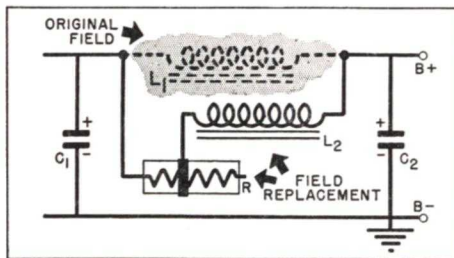

FIG. 26. A choke-resistor substitute for a speaker field.

the field is used as a choke like L_2 in Fig. 22A or L_1 in Fig. 23, you will have to provide a choke coil to obtain equivalent filtering. For an a.c.-d.c. set, order an a.c.-d.c. filter choke, which is usually rated at 10 henrys and 50 ma. The resistance of this choke will be

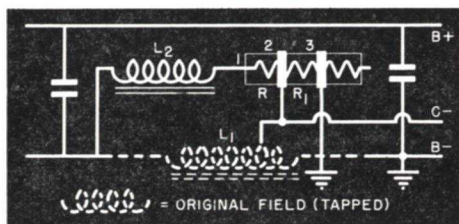

FIG. 27. A substitution for a tapped speaker field.

comparable to the field resistance.

You will have to use both a choke and a resistor in a standard a.c. receiver, since the average choke coil has a resistance of only 300 to 600 ohms, while a speaker field resistance may be anywhere from 1000 to 3000 ohms. The proper connections are shown in Fig. 26, where the choke L_2 and the resistor R replace the original field (shown as L_1).

The replacement choke coil should have an inductance rating between 10 and 30 henrys and a current rating at least as high as the receiver current. A choke rating of 75 to 100 ma. is usually sufficient.

If the field was tapped and used to supply bias for the power output tubes (Fig. 27), you can follow the same general method of replacement used in Fig. 26, except that the resistor must have two slider taps. Connect one of these sliders to the point connected to the tap on the original field, and connect the other slider to the set chassis (see Fig. 27).

Make the resistance between points 1 and 3 of this figure approximately equal to the original field resistance. Then bring slider 2 toward slider 3 until the voltage drop across section R_1 delivers the proper bias for the output tubes.

Lesson Questions

Be sure to number your Answer Sheet 47RH-2.

Place your Student Number on every Answer Sheet.

Send in your set of answers for this lesson immediately after you finish them, as instructed in the Study Schedule. This will give you the greatest possible benefit from our speedy personal grading service.

1. Suppose a power transformer stops smoking and cools off when the tubes are removed, even though the on-off switch is still turned on. Was the overheating due to an overload, or is the transformer defective?
2. Suppose the tester shown in Fig. 1 is being used to check the primary current of a transformer having an internal short. Should the lamp light: 1, dimly; 2, brightly; 3, or should it show no light?
3. Suppose a power transformer is available which has a filament winding rated at 6.3 volts and 4.5 amperes. The set in which you want to use it has tubes rated at 6.3 volts, and they draw a total of 2.7 amperes. Can the transformer be used?
4. An input push-pull transformer has a defective primary, and a check of the secondary shows a resistance of 300 ohms. Is the transformer an input for a class A output stage, or for a class B stage?
5. Suppose a plate by-pass condenser in an i.f. stage becomes defective. Would you use 50 $\mu\text{mf.}$, .01 mfd., .5 mfd. or 8 mfd. as the replacement capacity?
6. If a 10 mfd., 150-volt electrolytic condenser becomes defective, could a 16-mfd., 250-volt condenser be used as a replacement?
7. When you install a replacement r.f. coil having a variable inductance, is the coil inductance adjusted at 600 kc., or at 1400 kc?
8. Suppose a receiver using the a.f. volume control circuit of Fig. 21C has a defective control rated at 500,000 ohms. Could you use a 1-megohm audio type control as a satisfactory replacement?
9. If a receiver uses a dual electrolytic filter condenser having a common positive lead, can you replace it with a dual electrolytic condenser having a common negative lead?
10. If you do not know the voice coil impedance of a loudspeaker, how can you approximately determine its value?



YOUR REPUTATION

Success in business depends on a number of things, but your reputation is probably the most important of these. Your sense of "fair play," and of honest dealing will determine your reputation, whether you operate a store or work as a serviceman. To help you get started properly, here are a few of the business rules you should memorize well:

Keep your promises. Be careful to make only promises which you are reasonably sure you can keep.

Keep accurate records. Only records can show what your profits are; what your costs are; and what your tax bill is. Adequate records are needed to show you how to adjust your charges so that you can be fair to both yourself and your customer.

Be honest in all your dealings. Honesty goes far beyond "dollars and cents"—it includes fairness to your employees; telling the truth in your advertising; guaranteeing your work and your merchandise; and reasonableness in dealing with your suppliers.

Yes, a *good* reputation is certainly to be desired. With it, you are well on the road to success!

J. E. Smith