

**SERVICING NOISY  
AND  
INTERMITTENT RECEIVERS**

*Finish*

43RH-1

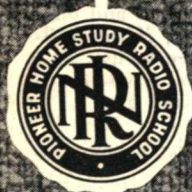

**NATIONAL RADIO INSTITUTE**

**WASHINGTON, D. C.**

**ESTABLISHED 1914**

## STUDY SCHEDULE No. 43

For each study step, read the assigned pages first at your usual speed, then reread slowly one or more times. Finish with one quick reading to fix the important facts firmly in your mind. Study each other step in this same way.

1. How Noise is Produced ————— Pages 1-6

Some noise is always present, due to atmospheric disturbances and normal circuit disturbances. However, the loud popping, crackling, sputtering sounds that result in a hurry-up call to a serviceman are caused by poor connections (which in turn produce arcing or partial open circuits) or by partial short circuits. Electrolysis, mechanical stresses, poor soldering and aging all produce these poor connections. A list of common parts defects is included.

2. External Noise Sources ————— Pages 6-9

The antenna system and man-made electrical disturbances can cause a great amount of noise. Hence, you must first determine whether the noise originates within the set or is external. If external and due to antenna system defects, you should go over the system and put it in good order. Certain household appliance defects can also be cured, but man-made interference is the subject of another lesson.

3. Localizing Noise Within the Set ————— Pages 9-17

Again we follow the standard service procedures to localize the defective stage, circuit and part. Stage-blocking or signal-tracing are the most useful techniques to use.

4. Intermittent Reception ————— Pages 18-21

The manner in which parts defects produce intermittent operation or intermittent hum, oscillation, noise, etc. is given here. You are shown that just certain parts defects are likely to cause intermittent trouble, which helps to narrow down the possibilities in all cases except intermittent operation or intermittent noise. This section shows how and why intermittent troubles occur.

5. External Intermittent Troubles ————— Pages 21-24

First, determine the exact nature of the complaint. In many instances, you will find that atmospheric conditions are the cause of the complaint. In cases of intermittent noise or fading, the antenna system may be at fault.

6: Localizing Intermittent Troubles ————— Pages 24-36

Having localized the trouble to the set, you are ready to locate the defect. Here is a case where wiggling parts and connections, thumping tubes and other parts, and pulling on wires may disclose the defect. However, if this fails, localization must be made. The signal tracer is the best device to use, as it breaks the receiver circuit up into smaller sections and makes it possible to find the trouble more quickly. However, other methods are given also.

7. Answer Lesson Questions, and Mail Your Answers to N. R. I.

8. Start Studying the Next Lesson.

COPYRIGHT 1944 BY NATIONAL RADIO INSTITUTE, WASHINGTON, D. C.

## SERVICING NOISY AND INTERMITTENT RECEIVERS

### How Noise Is Produced

NOISE is another of the annoyances which always exist to a certain extent in a radio receiver. The residual noise level may be very low in low-sensitivity midget receivers, but it is liable to be rather high in larger sets having more tubes and greater amplification.

What is noise? It may perhaps best be described as an unpleasing sound or sounds with irregularly-produced, sharp peaks—for example, popping, crashing, hissing, frying, clicking and scraping sounds. Whether a sound is a noise or not depends on the materials used in producing it. Striking a board with a hammer produces a noise, as the board structure and shape produce irregular sound waves. However, when a piano string is struck by the hammer in the piano action, a pleasing musical sound is produced, because the string vibration produces a regularly repeated wave form consisting of a sine wave fundamental plus harmonics. That is another characteristic of a noise—it is not a sine wave nor is it produced by a sine wave source. Thus, hum, squeals and whistles are not classed as noises and are therefore treated in other lessons.

► You can demonstrate one kind of noise to yourself with the simple circuit shown in Fig. 1. Place a pair of headphones in series with a flashlight cell, attach one side of the circuit to the file, then draw lead A across the file teeth. You will hear a clattering noise in the phones which will be quite similar to the noise caused by several radio difficulties.

► The irregular nature of noise is easily demonstrated by a c.r.o. With *no signal* tuned in on the receiver and the c.r.o. connected to indicate the audio output, you should get a straight line pattern similar to that shown in Fig. 2A. (You may get a small hum ripple.) Should you notice irregular jagged lines instead, as in Fig. 2B, then noise is present.

If a sine wave signal is fed through a noisy set, the noise will distort the pattern, as in Fig. 2C.

On the c.r.o. screen, a regular broadcast signal may look somewhat like a noise signal because it is continuously changing and is so crowded and complex. The noise pattern is more

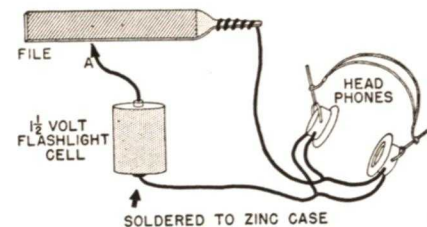

FIG. 1. While scratching the file with contact "A," a clattering, static-like noise will be heard in the phones.

broken up, but to avoid confusion, do not have a broadcast signal tuned in while looking for the noise source.

► The very sharp changes in noise signals mean that noise pulses contain frequencies ranging from low audio frequencies on up into the r.f. spectrum. If any noise pulse gets into a tuned circuit, some component of the pulse will probably be at the right frequency to pass through the tuned circuit just like a radio signal, or it

may "shock excite" the tuned circuit into momentary oscillation, producing a noise-modulated signal capable of being passed on through the radio. The tuned circuits do help keep out noise at other frequencies, however. We may pick up more noise at some frequencies than at others, but this is either caused by the noise source radiating better at those frequencies or by the receiver being more sensitive at those points.

### BACKGROUND NOISE

Before studying noises produced by defects, let's learn something about the kinds of noises which may be heard at any time from a sensitive receiver.

**Atmospheric Disturbances.** Practically any radio will pick up atmospheric noises at times. (F.M. receivers using limiters have the ability to wipe out the amplitude variations producing noises, and so do not reproduce atmospheric noise when an incoming signal has the limiter saturated.) These noises, caused by electrical disturbances in the atmosphere, are usually much worse as thunderstorms approach. The short waves are particularly subject to both these and man-made noises (to be described later.) You may be called in at some time to see if you can get rid of atmospheric noise on the short-wave bands. Since the amount of noise varies with the season and the wave bands used, suggest the trial of other bands. Sometimes a better aerial system, particularly the noise-reducing variety, will prove helpful by giving a better signal-to-noise ratio. However, since you have no control over atmospheric disturbances, you must explain the trouble to the customer instead of making any actual repair.

**Circuit Noise.** We usually consider

that each and every electron is perfectly controlled in ordinary circuit actions. Actually this is not true—there is always a certain amount of random electron motion. This random motion will have no effect as long as it is small compared to the electron movement we introduce as a signal. However, when we try to amplify signals so weak that they are not much larger than the random electron movement, we run into trouble with circuit noises.

► Similarly, tubes contribute greatly to the amount of noise. We think of the electrons emitted from the cathode as moving steadily to the plate. Actually, they tend to form small bunches and go over to the plate in shots or spurts. (This is called the "shot effect.") The average number of electrons emitted over a period of time is constant, but from instant to instant there are small variations in the number of electrons emitted. This effect is particularly noticeable in the first detector of superheterodynes. However, as long as these variations are small with respect to the signal, little noise is heard.

If a high gain radio receiver is tuned to a point on the band where no signals are picked up and the volume control is turned up, you will hear considerable amounts of noise. Then, as you tune in a signal, the a.v.c. circuits reduce the sensitivity of the set. If this signal is large enough, the amplification drops considerably. This reduces the noise level, but the strong signal is still reproduced at full volume. When this happens, the noise becomes unnoticeable, because the signal-to-noise ratio is so high. Therefore, you will always find receivers more noisy between stations, or when you attempt to pick up weak long-distance signals, than they are on strong local stations.

### BASIC CAUSES OF NOISE

Now let's turn to noise-producing defects. The sharp, ragged peaks and breaks in the signal produced by noise show that the noise is caused by a sharp and sudden change in current or voltage in a signal circuit or electrode supply circuit.

If we open and close a circuit rapidly, we make sharp changes in the circuit current and so cause noise. Similarly, if a short circuit across part of a circuit opens and

shown by a visible sparking, then starts through the air space. Since the resistance of the air gap varies rapidly, the circuit current is changed erratically and noise is produced. This arcing often occurs in circuits where oscillations may be set up, with the circuit in turn radiating electric and magnetic fields. This circuit then acts as a small transmitter, introducing its noise signal into other circuits.

*Thus, we can say any circuit condition producing an irregular current change will produce noise. Hence, a rapidly closing and opening contact of any kind can cause noise by producing either a partial open circuit or a partial short circuit. An arc also will produce noise.*

### HOW POOR CONTACTS ARE PRODUCED

Since some sort of faulty contact is normally responsible for noise, let's learn how these poor contacts develop so we will know where to look for them.

**Electrolysis.** One of the most prevalent sources of a partial open or arcing contact is a form of corrosion produced by electrolysis. This corrosion exists where moisture or chemical deposits on the surface of a wire provide a conductive path for current flow in and out of the wire. This flow sets up an electrochemical action, producing a form of oxidation or corrosion which eventually eats away the conductor. This action is hastened if the surrounding air is salty (near a seashore) or contains industrial fumes, or if there is a deposit of corrosive soldering flux on any of the circuit wiring. Tropical climates, which have high humidity, cause so much corrosion that sets for use in these climates must be specially insulated and moisture-proofed.

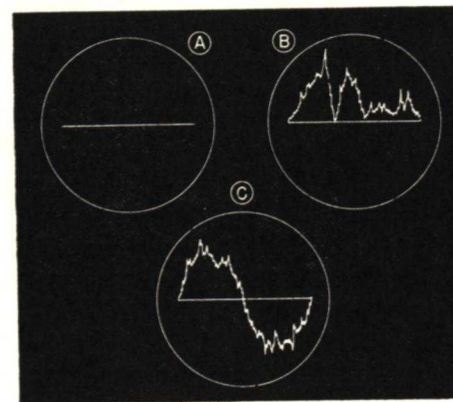

FIG. 2. The c.r.o. pattern for no noise (when no signal is tuned in and the hum level is low) is shown at A. A noise pattern is shown at B, while C shows noise mixed with a sine wave signal. Noise patterns resemble the rapidly changing patterns produced by voice or music modulations, except for being more irregular in shape and timing. To avoid confusion it is best not to have a broadcast signal tuned in while testing for noise.

closes rapidly, it will cause large changes in the current flow or in the signal voltage and will produce a noise.

Noise may also be produced by sparking or arcing at a poor contact. An arc is formed when two points at different potentials are so close together that a spark can jump between them. When this happens, the air in the gap ionizes and becomes semi-conductive. A current flow,

We can particularly expect corrosion to occur at exposed joints. The action will be retarded if the joint is wax-coated or is insulated by a compound or insulating tape which does not absorb and hold moisture and contains no active chemical ingredients itself.

► Similarly, when coil windings are well protected, corrosion rarely develops on the winding itself. However, there is always the possibility of chemical deposits from the sweaty hands of workers, soldering fluxes and other material, being under the protective coating. In windings with many layers, such as audio transformers and speaker fields, electrolysis is liable to be set up between layers.

Remember, this electrolysis sets up an action which will eat through the wire itself. As the wire is eaten away, the reduced cross-sectional area produces resistance at this point. The resulting heat will burn away the remaining wire, providing a momentary open circuit. If the voltage is sufficiently high, an arc may form across the break. The heat of the arc may then melt enough of the copper to close the circuit again, and the action may be repeated over and over.

**Mechanical Stress.** Often, wires or parts are mounted so that contraction and expansion resulting from temperature changes may cause a break. Thus, you may find a resistor or condenser with its leads pulled so tightly between two mounting points that contraction caused by cooling will pull the leads loose from the part. Coil forms may expand when heated and thus break wires pulled tightly to the terminals. If the broken ends of the wire are held in place by wax or coil dope, an arc may form.

**Poor Soldering.** Again we must

emphasize the importance of good soldering. Usually the original soldered joints in a receiver are well made. However, servicemen all too frequently do sloppy soldering work. A cold-soldered joint almost invariably traps a considerable amount of soldering flux within the joint, where it may cause a high resistance between the wires being joined together. Always be suspicious of any

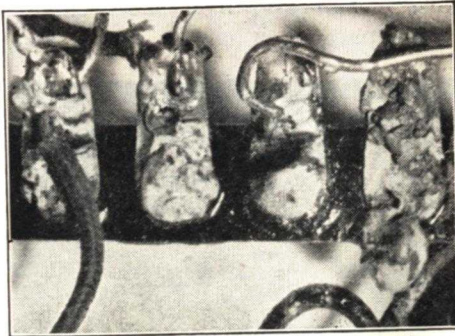

An example of poor soldering. The lumpy, cracked appearance shows too much solder was used and the joints were not heated enough.

joint with a large blob of solder on it. Upon heating such a joint, you will frequently find that soldering flux boils out of it.

Also, the average serviceman uses entirely too much solder. Great amounts of it often drip down between terminals. These may form a path between terminals and provide partial short circuits which can cause noise.

**Watch your own soldering.** Heat the joint thoroughly before applying solder, then use solder sparingly. If you have a receiver for repair and observe poor soldering, go over these joints with a hot soldering iron to remove excess solder. Be certain excess amounts of flux are completely removed.

**Effects of Aging.** Insulation is greatly affected by aging. It will

dry out and crack, so that when wires are bundled together partial shorts can exist between them. If an arc occurs between terminals of a tube socket, the socket may carbonize and thereafter provide a semi-conductive path between terminals.

► Dust and dirt will inevitably collect on a radio receiver and will produce leakage paths between tube socket terminals, between parts mounted on terminal strips, and between the plates of tuning condensers.

► Wave-band switches and other contacts which depend on spring tension will eventually lose this tension with use and thus become noisy.

► The volume control is one of the most frequent sources of noise. Poor contacts may develop between the rotor arm and its contacting ring and

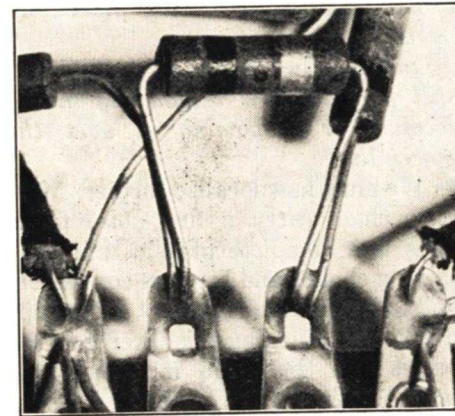

Good soldering produces a smooth, even coating of solder. The joints have been heated sufficiently to melt the solder and just enough solder has been used to coat the joint thinly.

between the rotor arm and the resistance element. The element itself wears away and becomes pitted, presenting differing contact resistances at different points.

#### COMMON PARTS DEFECTS

The following list shows the more common sources of noise within the radio receiver. The items are ar-

ranged in approximately the order in which they are most commonly found.

#### Tubes:

Internal shorts; poorly welded connections; gas.

#### Volume Controls:

Worn resistance strips; poor contact to resistance strip; poor contact between rotor and contacting ring.

#### Coils, Air or Powdered-Iron-Core:

R.F., oscillator or i.f. coils partially opened by corrosion; shorts between turns; leads snapped near lugs; coil shields making poor contact to chassis.

#### Coils, Iron-Core:

A.F. transformers, power transformers, chokes and speaker fields corroded where the winding and external leads join; shorted layers in windings; shorts between windings and core; loose laminations; poorly grounded shielding.

#### Tuning Condensers:

Dust and metal particles between plates; worn wiper contacts; plates bent or warped out of shape.

#### Resistors, Candohm (5- or 10-watt resistor mounted in a metal housing, used for voltage dividers):

Poor contacts between taps and resistor elements; internal arcing; shorts between turns on wire-wound resistor elements.

#### Switches:

Dirt and corrosion on contacts; possible loss of spring tension.

#### Carbon Resistors:

Cracks in the resistor element.

#### Condensers, Wet Electrolytics:

Internal arcing caused by sludge partly shorting the plates; scintillation (arcing) caused by high-voltage peaks breaking down the

dielectric film, poor contact to grounding bracket on chassis.

### Leakage Paths:

Leakage between terminals of a tube socket or along terminal strips, caused by dust, dirt, soldering flux, excess solder, or carbonization of the insulating material.

The preceding list gives just the

*more common* troubles in their approximate order. You may find other troubles, or you may find the order of troubles is different, depending on the kinds of receivers you work on and the type of climate you have. The more moist the climate (particularly if the percentage of salt or corrosive fumes is high), the greater the amount of trouble.

## External Noise Sources

Noises are not always caused within the set. It is well to know what external sources can cause noise, because you will be called on to cure these troubles as well.

### LOCALIZING NOISE TO SET

As with other complaints, question the customer carefully. Find out if there is anything about the noise which will reveal its source. A noise that occurs at a certain definite time every day, and at no other time, is undoubtedly caused by some external source, perhaps some machinery in the neighborhood. If noise is heard every time the oil burner comes on, it is probably caused by the oil burner electrical system. Also, be sure the customer is not complaining about normal atmospheric disturbances.

If no clue leads you to the source of the noise, turn on the radio to confirm the complaint.

► If again no clue leads to the trouble, the next step is to disconnect the aerial and ground leads from the set, connect them together, and short the aerial and ground posts on the receiver with a small length of wire. (If the set has only an antenna, disconnect it and ignore the statement about shorting the aerial and ground terminals.)

With the antenna and ground leads

moved well away from the radio, turn the volume control all the way up and rotate the tuning dial. Adjust the other controls also. *If the noise is not present, the trouble is outside the set*, and is either in the antenna-ground system or is caused by an external noise source being picked up by the antenna.

On the other hand, *if the noise is still present, it is originating in the receiver or is coming in over the power line.*

► We must now localize further. Most servicemen carry a line noise filter. This is a complete plug-in unit containing chokes and by-pass condensers and is obtainable from any radio supply house. Plugging this filter into the outlet and the radio into the filter blocks noises from coming in over the power line. Hence, if the noise stops, it is coming in over the power line; if it continues, it is probably originating in the receiver.

Usually, if the noise is traveling over the power lines, disconnecting the antenna and ground will reduce its intensity (because the noise is probably being radiated from the power lines and introduced again via the antenna).

**Using a Test Set.** A test receiver—a three-way (a.c.-d.c.-battery) portable receiver with a built-in loop and

provision for an external antenna—is excellent for localizing the noise source. To use it, treat the customer's radio as directed in the previous section, and at the same time operate the test receiver on its batteries (not plugged into the power outlet). If noise is heard in both receivers, it is of external origin.

You can check the customer's antenna by connecting the test receiver (still operating on batteries) to the antenna, and you can plug the test receiver into the power line outlet and switch to power line operation to determine if noises are coming in over the power line.

► If the customer's receiver has a loop antenna, it is not practical to disconnect the loop. However, you can rotate the loop if it is adjustable, or rotate the entire cabinet if a fixed-position loop is used. If the noise varies in loudness when the loop is rotated, the loop is probably picking up the noise. This test will not always work, because the noise field may be so strong that it apparently has no direction. If so, using an extra receiver is the only sure test in the customer's home.

► Of course, you can always carry the customer's radio to your shop. If the set is quiet in the shop, the noise is probably originating in or near the home of the customer (unless jarring the set in transit has temporarily cured some internal trouble). However, if the same noise continues, it is definitely originating within the set.

### OUTSIDE NOISE

There are many external sources of noise which you will often be expected to run down.

**Man-Made Interference.** Noises are caused by faulty switch contacts, arcing at motor brushes, and other faults of man-made apparatus. This

subject is so broad that complete details for running down and curing such interference are given in another lesson in your N.R.I. Course.

**Antenna System Troubles.** Many things may happen to make an antenna system a source of noise. You may find the antenna is down altogether, or is touching another wire, a tree, or some other object. Some one may have connected another lead-in to the same aerial wire. There are liable to be corroded contacts where the lead-in wire joins the antenna, as well as at any other point where the lead-in wire is not a continuous wire

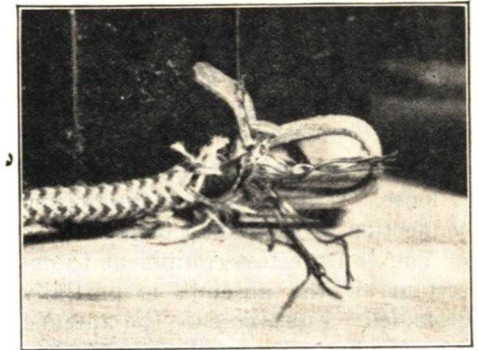

Loose wire ends touching the chassis will produce noise. Be sure ALL strands of wire are twisted together and contact ONLY the terminal to which a connection is intended.

—at a lightning arrester or at a lead-in strip, for example.

You may find a loose connection at the binding post or Fahnestock clip where the antenna or ground leads fasten to the receiver—or even frayed ends of the lead-in wire shorting to the set chassis. Carefully examine all these items, even going all the way up to the antenna wire if it is a logical suspect. If any of these defects are found, repair the condition and try the receiver again.

► If nothing is visibly wrong with the antenna system, reconnect the antenna and ground leads to the re-

ceiver. Wiggle the wire from the receiver to the window strip to see if noise is produced. Also wiggle the strip and shake the lead-in wire itself. If there is a poor connection at any point, you will notice an increase in the noise level as the joint is moved.

Many modern all-wave antennas have a two-wire, twisted-pair lead-in. After these antennas have been up for several years, the insulation between the pair of wires may rot to such an extent that shorts can develop between these leads. Shaking the lead-in wire vigorously will usually show up the trouble by increasing the noise greatly.

If you suspect the lightning arrester is defective, disconnect it and see if the noise stops. Be sure the connections at the arrester are clean and tight.

Wiggle the ground lead to see if it is loose. If it is, tighten the ground connection or grounding clamp.

► You can use test equipment to determine if the antenna is partially grounded. First, be sure the antenna is not in any way involved with electrical wiring by checking with a voltmeter between the antenna lead-in and ground. (Use an a.c. meter in districts where the power lines are a.c. and a d.c. meter in a d.c. district.) You should get no voltage reading. If you do find voltage, be careful to clear up the short before reconnecting the antenna to the receiver.

If you find no voltage, check for grounds with an ohmmeter. Connect one ohmmeter probe to the antenna lead-in and the other to ground. Shake the lead-in and watch for an intermittent or continuous reading, showing a short between the antenna and some grounded object. Use the highest range of the ohmmeter.

► When the customer complains of noise that occurs during rainstorms or

when there is wind, watch out for an antenna erected so that it can sway in the wind and touch foreign objects (such as metal gutter piping, another antenna, or metal weather-stripping). You may find that rainstorms change the resistance to ground by providing leakage paths across insulators. Usually a high-range ohmmeter will show if any leakage exists. If you find any, the antenna system should be repaired before going further.

**House Plumbing and Wiring.** If the complaint is noise when any one walks around in the room, the resulting vibration may be jarring the radio (this condition will be discussed later), but probably, some water pipes or electric cables are rubbing together under the floor. This will cause a great amount of noise. It can be cleared up either by wiring the pipes together to make a good electrical connection between them or by wedging the pipes apart with a piece of wood so they cannot touch. Move electric cables apart and away from pipes.

An unusual case is one where static discharges are produced when walking across a thick rug. This annoyance will occur only under certain conditions of temperature and humidity. If these conditions cannot be controlled, moving the radio or the rug to another room is the only cure, although a more efficient antenna system may be helpful.

► Sometimes noise will be caused by loose connections in the electrical wiring system. Be sure to wiggle the receiver plug in its wall or floor outlet. If a great amount of noise occurs, bend the plug prongs to make better contact or advise installation of a new wall outlet.

Many people use cube taps (devices for connecting three or more fixtures to a single wall outlet). These devices quickly lose spring contact

tension and become noisy, so should be eliminated if possible. Remove all such extra appliances and plug the radio directly into the outlet to see if this clears up the noise.

Be on the lookout for a line cord with a frayed covering near the plug. Too many radio owners grab the cord to pull the plug out of a wall socket. This soon frays the insulation and loosens the connections between the cord leads and the plug.

**Electric Fixtures.** A great amount of noise is caused by light bulbs which are just ready to fail and by poor wiring in floor lamps and other electrical appliances about a home. Always be sure to ask the customer if the noise is noticed only when he turns on his floor lamps, the light in the dining room, or some other switch about the house. If so, recommend the fixture be examined by an electrician (or go over it yourself if you also repair lamps, etc.).

Noise impulses of this kind will usually travel to the receiver over the power line. They are particularly apt to occur where antenna leads run

parallel to power cords for any distance, or where the defective lamp is plugged into the same outlet as the radio.

### SYMPATHETIC VIBRATIONS

Sound waves from the receiver loudspeaker may cause mechanical noise by setting parts of the radio or objects in the room into vibration. The mounting bolts holding the receiver in the cabinet, and the glass or celluloid covering over the dial are common offenders. Receiver cabinet doors and handles, and loose ornaments on or near the set are other noise sources you may find. Careful listening, and touching objects with your hand to feel or stop the vibration will lead you to the offender. Obviously, the part or object must be fastened more securely or removed from the room to correct this condition.

You will probably be called in oftener than you expect to correct conditions like these. Customers often think such noises come directly from the speaker.

---

## Localizing the Noise Within the Set

Once you know the noise source is within the radio, you must localize it to a particular section, stage, circuit and part.

Noises have certain characteristics that sometimes help and sometimes hinder localization steps. If noise acted only as a signal and followed the signal paths exactly, you could use the ordinary methods of localization. However, a source of noise will often radiate electric and magnetic waves which may be introduced at several points in the receiver. For example, arcing at a corroded fuse

clip, as in Fig. 3, will not only introduce a signal which may follow the power supply leads to all stages, but will also produce radiated fields which may enter any stage directly in spite of the receiver shielding.

Mechanical shocks caused by jarring the receiver, or electrical shocks caused by a sudden change in current (snapping the receiver or a lamp switch off and on) may make the noise stop or start. This fact puts noise in a class with intermittent reception and at times makes the source of trouble rather difficult to locate.

## EFFECT-TO-CAUSE REASONING

Once you decide the noise is in the set, pay careful attention to the effect of rotating the various controls. If turning the volume control to zero cuts the noise off altogether, and the set is a modern one with the volume control at the input of the audio amplifier, then the noise is developed in the r.f.-i.f. section of the receiver. If

and forth a few times to see if this introduces unusual noise or clears up the noise temporarily. Either effect will indicate that the wave-band switch itself is the source of noise, provided you are not jarring associated parts or wires. If an examination leads you to the switch, clean it carefully, bend its contacts, or replace it—depending on the nature and extent of the trouble.

**Tuning Condenser Troubles.** Try tuning the receiver. Any loud noise occurring while the dial is being rotated indicates dirt or metal particles between plates, touching plates, or poor wiping contacts in the tuning condenser gang. Reception may be cut off altogether at low frequencies; this usually means shorted plates. Oscillations may occur when poor wiping contacts develop.

Bent or warped plates can sometimes be straightened. Some older types warp so badly they must be re-

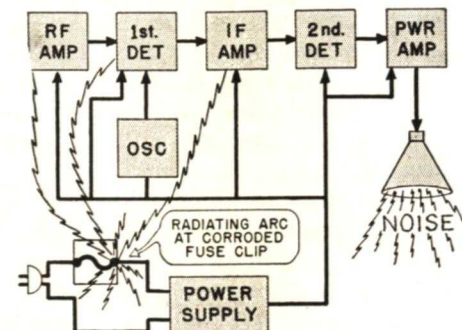

FIG. 3. Arcing produces a noise radiation which can travel directly to several stages at once.

the noise is just reduced, however, it is getting into more than one stage and will have to be localized by other means. On the other hand, if the noise remains as strong as ever, it must be in the audio amplifier or power supply.

► Notice whether the noise becomes much worse while the volume control is rotated. If so, the volume control itself is probably the source of the noise.

Watch for additional clues. If the volume control is defective, you will frequently find that noise is accompanied by erratic changes in volume and, in some cases, by hum.

► Rotate the tone and sensitivity controls also. These are made just like volume controls and are frequently a source of noise. Obviously, replacing them will clear up the noise they cause.

► Throw the wave-band switch back

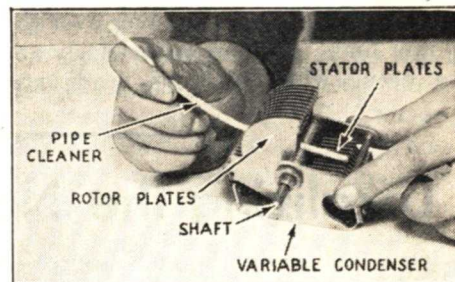

How to clean between tuning condenser plates with a pipe cleaner. (You do not have to remove the condenser from the chassis to do this cleaning; this one is used for illustration only.)

placed. The plates may be cleaned of dust by running a pipe cleaner between them.

► Metal particles, or condensers which are difficult to reach, may require the more drastic treatment of burning out the dust and metal flakes with high voltage. Make up a circuit like that in Fig. 4, using a power transformer

with a protective lamp bulb (60 to 100 watts) in series with the primary. **DISCONNECT THE R.F. COIL LEADS FROM THE TUNING CONDENSER BEFORE USING THIS DEVICE.** Otherwise, the high voltage will burn out the coil. To use it, connect the high-voltage winding across the tuning condenser section, close switch *SW*, and rotate the condenser plates. Large sparks will occur as metal slivers are burned out. If the plates touch, the protective lamp will light; you should then open switch *SW* and clear up the short if possible. After the repair, remove the transformer connections and reconnect the r.f. coil leads.

## STAGE ISOLATION

If the tests so far have not localized the trouble, you can localize the defective stage either by using a stage blocking or stage interruption test, or by using a signal tracer.

**Stage Blocking.** The volume control test previously described is a form of stage blocking, since it prevents noise signals originating in the r.f. section from being passed on to the a.f. amplifier through normal channels. Of course, if the noise is being radiated, it may get around the volume control anyway.

In using the following methods, always remember that the noise may radiate around stages or travel through supply leads, as well as travel along the normal signal paths. However, the noise will always be diminished as long as you are blocking between the noise source and output, and will usually disappear entirely when the defective stage is blocked.

► There are several ways of blocking stages, all of which are intended to make it impossible for the stage to pass a signal.

One of the most effective ways is to

pull out tubes, working from the output back toward the input. The noise will stop or decrease greatly each time you remove a tube, as long as the noise originates further back toward the input. When you pull out a tube and find the noise remains as loud as ever, the trouble is probably in the last stage interrupted (that is, the next stage toward the loudspeaker). Both tubes must be pulled out simultaneously to block a push-pull stage. ► Of course, the tube-pulling technique cannot be used in a.c.-d.c. receivers where pulling out a tube would interrupt the entire filament circuit.

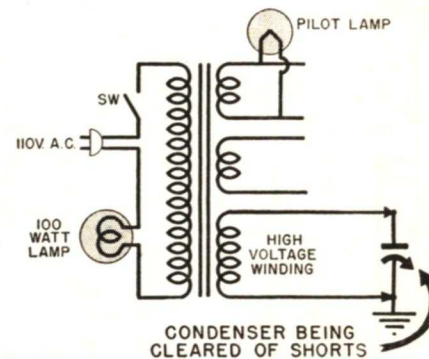

FIG. 4. A high voltage applied to the plates of a tuning condenser will burn out metal peelings from between the plates.

or in battery sets where removal of one tube might put excessive filament voltage on the others. In these cases, you must short the signal input circuit, stage by stage, by shorting the resistor or transformer secondary across which the signal normally appears. If one end of the input part connects to chassis or ground, you can hold a test lead between the control grid terminal and the chassis. However, if the return end of the part connects to some bias source, you must hold the test lead right across the part terminals.

Block each grid input in turn, moving the test lead along from grid circuit to grid circuit toward the an-

tenna. The noise will be blocked altogether or reduced greatly as long as the source is further back toward the antenna. When you come to a grid circuit where blocking does not affect the noise, however, the noise is either in that same stage plate circuit or in the coupling device to the next stage toward the loudspeaker. In other words, the defect is between the blocked grid circuit and the next grid circuit toward the loudspeaker.

It is possible to block the output device also, if you are careful to avoid short circuiting the plate supply. The

the volume control all the way up and rotate the tuning condenser gang. The noise will still continue, which shows it is originating in the receiver or coming in over the power line. A line filter does not affect the noise, so you know it is in the set.

Rotate the volume control to zero volume. This partially cuts out the noise, showing that it is in the r.f.-i.f. section of the receiver.

Turn the volume control back up again. If this is a standard a.c. radio, pull out the second detector tube. This will block the noise or reduce

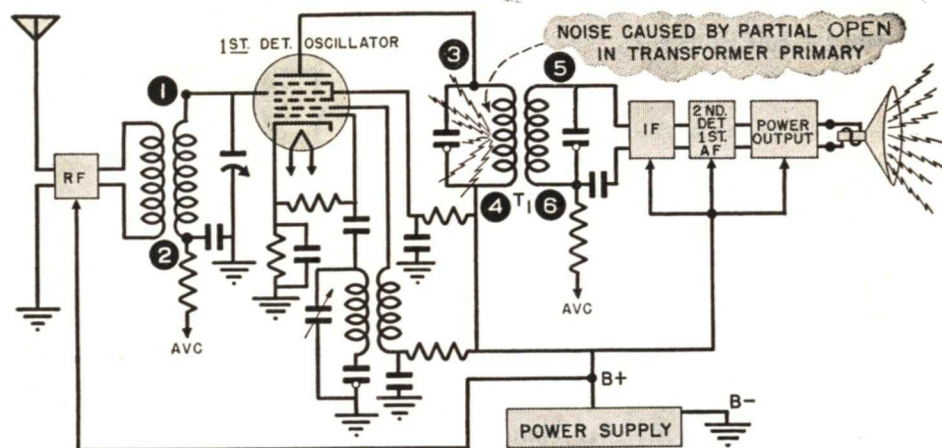

FIG. 5. A typical converter stage, with noise produced by a partial open in the i.f. transformer primary.

test lead must be held *across the load only*. The same procedure as for grid blocking is then used.

**Examples of Blocking.** Suppose you have the receiver shown in Fig. 5, in which a partial open in the primary of the first i.f. transformer  $T_1$  causes a noise-producing variation of the mixer plate current, and produces a rapid machine-gun-like crackling in the speaker. Here's how you could localize the trouble:

First disconnect the aerial and ground and short the binding posts together with a piece of wire. Turn

it to a very low value. Replace the second detector in its socket, then pull out the i.f. tube. The same blocking will occur. Replace the i.f. tube, then pull out the detector-oscillator tube. This time the noise will stop completely.

Replace the detector-oscillator tube, then pull out the r.f. tube. The noise will continue. This shows you that the noise source is in the detector-oscillator stage.

► Now suppose the receiver is an a.c.-d.c. set or is battery operated, so the tubes cannot be removed. You should

localize the noise to the set, then to the r.f. or a.f. section, as you did with an a.c. receiver. You can then find the defective stage by blocking the stage input or output circuits (or both), one at a time, moving from the output toward the input.

Fig. 6 shows how to use test leads for blocking the audio amplifier circuits. Positions 6 and 7 block the outputs of tubes  $VT_3$  and  $VT_4$  respectively. Positions 4 and 5 block the inputs of tubes  $VT_3$  and  $VT_4$  respectively. If only one of these positions is used, only one of the push-pull tubes will be blocked, and noises originating nearer the set input will pass through the tube which is not blocked. This is all right if you are trying to determine which output stage is defective, but trouble in another stage requires blocking both tubes in the push-pull circuit. Therefore, you should apply the test leads at both 6 and 7 or both 4 and 5 simultaneously. (Test leads with clips at each end should be used for this purpose), or use one test lead from plate-to-plate or from grid-to-grid.

If the tests at positions 6 and 7 or at 4 and 5 block the noise, you can move back either to position 3 at the output of tube  $VT_2$  or to position 2 at the input of tube  $VT_2$ . Finally,

move back to position 1 or to the grid circuit of tube  $VT_1$ .

► Blocking the output as well as the input lets you determine just which circuit in the stage contains the defect. For example, if the test lead held at position 3 eliminates the noise but the noise continues when you short-circuit the grid input at position 2, the noise must originate in the plate circuit of tube  $VT_2$ . If, on the other hand, you shorted only input circuits, you would go from positions 4 and 5 back to position 2 and wouldn't know whether the trouble was in the plate circuit of  $VT_2$  or in the grid circuit of tube  $VT_3$  or  $VT_4$ . (Usually, however, the noise source is in a d.c. circuit, so the plate circuit would be the logical suspect.)

► One difficulty of shorting the output circuit of a stage is that you deal with a high-voltage circuit and must be very sure you get between the right points. *Never short from plate to chassis*; this shorts the plate supply and may damage some parts in the plate circuit.

► This shorting procedure can be applied to the r.f. circuits shown in Fig. 5. Here, if the i.f. transformer were faulty, shorting between terminals 5 and 6 would eliminate the noise, but shorting between terminals 1 and 2

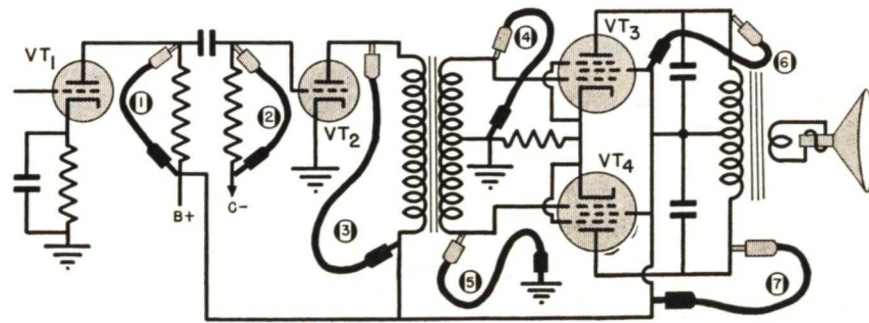

FIG. 6. Here are the positions for using test leads for the stage-blocking technique. Instead of blocking the output tubes individually, many servicemen block the entire push-pull stage with one test lead by holding it from plate to plate, or from grid to grid, of tubes  $VT_3$  and  $VT_4$ .



would not. This shows the trouble is in the detector-oscillator circuit.

Notice—you should short directly across the input part, not go from 5 to ground or from 1 to ground. There may possibly be a bias supply in the a.v.c. network somewhere; so going from 1 to ground or from 5 to ground would remove the bias and upset the circuit.

If you notice the noise diminishes as you block each stage but does not disappear, you can be fairly certain that the noise is arising in the power supply or is being fed through it.

**Signal Tracing.** Servicemen who have signal-tracing equipment generally use it instead of the signal blocking technique to localize noise. Remember that the noise is the signal, and in tracing to find its source you may move the signal tracer in either a forward or a reverse direction. If you move from the loudspeaker toward the antenna, the noise will decrease in intensity, since fewer stages of amplification are between the noise source and the signal tracer. When you pass through the defective stage, the noise will disappear entirely or become very weak.

If you move the signal tracer from the antenna toward the loudspeaker, no noise will be heard, or the noise will be at a very low level until the defective stage is reached. Then the noise will at once increase to a much higher level.

A visual indicator on the signal tracer, such as a magic eye or a meter, is not very satisfactory for noise tests. Use the audio output or feed the output of the signal tracer into the vertical plates of a c.r.o.

#### LOCATING THE DEFECTIVE CIRCUIT AND PART

After localizing the noise to a particular stage, first test the tube or,

better yet, try another one. If the noise continues the tube is not at fault, so you must again use effect-to-cause reasoning. You will recall that noise produces erratic changes in current flow. Therefore, if there is no signal coming into the set but the noise is heard from the loudspeaker just the same, an operating current is changing. This means that the noise source is probably in a plate or screen grid supply circuit.

An intermittent open in the control grid circuit would also cause noise by removing bias and thus changing the plate current. However, this kind of trouble is far rarer than a defect in a current-carrying circuit. If in the control grid circuit, it is probably caused by a defective connection of such a nature that mechanical jarring makes it open and close rapidly. Arcing will not be the cause, for there is no current flow to form an arc.

► On the other hand, if the noise is heard only when a signal is tuned in, the trouble may be in the speaker or may be caused by speaker vibration of some part or connection. If jarring the set and speaker does not make the noise appear or disappear, the source is in a signal circuit (a grid circuit or a circuit isolated by blocking condensers so no supply currents flow through it).

► A defect in an i.f. transformer makes a different noise from that caused by, say, a defective volume control. The actual sound produced will be a valuable clue, when you have had sufficient practical experience to recognize the many different noises which may develop.

► Once you localize the noise to a particular stage by the stage blocking method, you can use several different tests to determine just which circuit contains the defect. If you pulled out tubes, you wouldn't know just

which circuit it might be, although it is logical to first suspect a current-carrying circuit such as the plate or screen grid. If you used a test lead and blocked the input circuit, you would usually be justified in assuming the noise source was in a plate circuit.

Make a careful examination of the parts in and about the suspected stage. Look for the characteristic green spots which mean corrosion. Corrosion, by the way, is of course far more likely to occur in a current-carrying circuit than in a signal circuit which carries no direct current. If you put out the lights on your work bench, you can frequently see arcing if it is present.

**Meter Tests.** Since noise means that the current is changing rapidly, there will be a voltage variation somewhere in the set. Using a voltmeter between B— and the various tube electrodes, you should notice a quiver in the meter needle each time a burst of noise occurs if you are in the circuit containing the defect. Remember, however, that both the plate current and the screen grid current flow through the cathode resistor; also, sometimes the voltage change in one circuit will produce a change in another. Therefore, a voltage variation test may or may not locate the defect.

A voltmeter is particularly useful when the plate circuit is suspected. Remove the tube from the socket, which will stop the noise. Now, connect the voltmeter between the plate terminal of the tube socket and B— or the set chassis. If an erratic meter reading results, and the noise appears when the meter is connected but disappears when the meter is disconnected, the noise source is in either the plate load or the supply circuit. The reason you can hear the noise

even with the tube out is that the meter draws sufficient current through the defective part to start the noise again.

Should the noise not appear, connect the meter between the plate and the cathode terminals of the tube socket. If noise now appears and the meter reading varies erratically, the trouble is in the cathode circuit for that stage.

If the noise does not appear in either case, it is in another circuit. The screen grid and control grid circuits are logical suspects.

► With the set turned off, you can

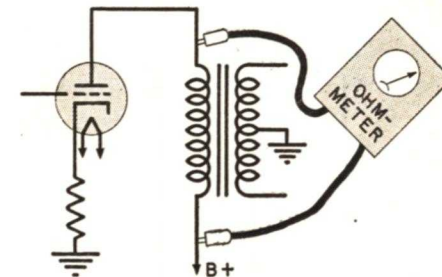

FIG. 7. How to connect an ohmmeter when looking for noise. The ohmmeter current flow is frequently sufficient to cause the defect to "act up," causing a wavering reading when the ohmmeter is connected across the defective part.

check with an ohmmeter directly across a suspected part (see Fig. 7). The ohmmeter will frequently provide the necessary current to cause the source of noise to act up. An erratic reading will show the part is defective.

**Shock Testing.** When the noise source is an i.f. or a.f. transformer in an a.c. set using a power transformer, you might short-circuit the plate terminal of the tube socket to the chassis momentarily with a screwdriver, while the set is turned on. The resulting high current will either burn out the defective spot altogether or will temporarily heal it. In either case, whether the noise disappears or

the set goes dead, you will have definitely localized the trouble to the plate load and can go ahead with a replacement.

You should replace the transformer even if this treatment temporarily heals it, for almost always the open will again occur or the part in question will have another corroded spot forming.

You don't have to worry about accidentally burning out a good part when making this test on an a.c. set with a power transformer, for a part in good condition can stand such a momentary overload without trouble.

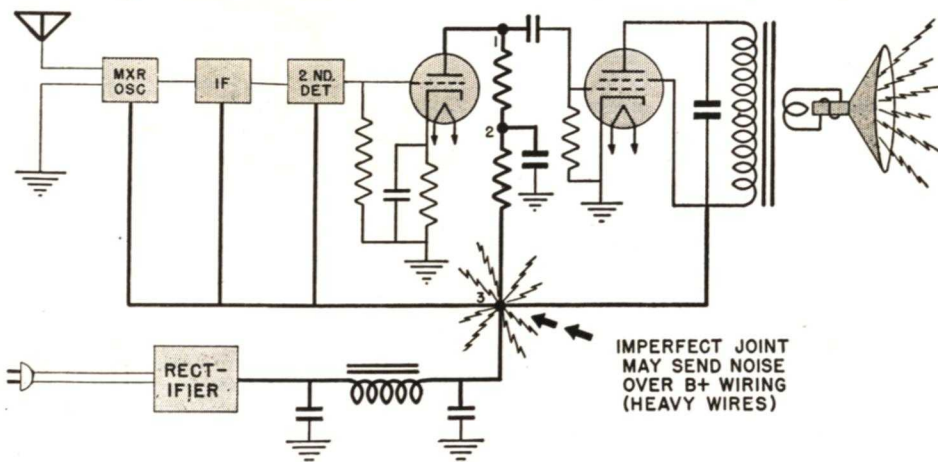

FIG. 8. How noises may travel over the wiring and thus get into several stages at once.

Any part which does burn out would fail sooner or later, anyway.

This shock test cannot be used safely on a.c.-d.c. or battery sets. In an a.c.-d.c. set, even a momentary short might ruin the rectifier tube, while in battery circuits there are no limiting factors on current flow and parts may be burned out or the batteries unnecessarily discharged.

**Signal Tracing.** Since noise is a complex pulse with components of many frequencies, you can often use the a.f. section of a signal tracer to locate noise in any part of the receiver. Bringing the probe near the

source of noise will frequently let you pick it up; you can thus localize the source by determining where the noise sounds loudest.

If this fails, you can touch the signal tracer probe to various points in the suspected stage to find the point where the noise is most intense. For example, the imperfect joint in Fig. 8 will radiate noise and send noise pulses over the B+ wiring. As you move from point 1 to points 2 and 3 the noise will get louder; right at the defect, it will be loudest.

► You can use a c.r.o. as a signal tracer by connecting the grounded

vertical plate terminal to the chassis or B— and the hot vertical terminal to a test probe. This probe is used exactly like the hot probe of a signal tracer. Turn on the c.r.o. vertical and horizontal amplifiers and turn up the gain controls. Keep the sweep frequency at some low frequency. The sweep will cause a line to be traced across the c.r.o. screen. When noise is picked up by the hot vertical lead, you will get a pattern similar to Fig. 2B, which will constantly shift.

If a sine wave is sent through an amplifier and the c.r.o. sweep is adjusted to the same frequency, any

noise picked up by the probe will cause sharp peaks, lines, and breaks on the sine wave (Fig. 2C).

**Mechanical Tests.** Many noises respond to mechanical shocks. If you find rapping on the chassis will make the noise appear, disappear, or become louder, it will frequently pay to search for the trouble by tapping suspected parts with a small wooden dowel or an insulated probe. The defective part will be the one which, when rapped, has most effect on the noise.

Be careful to rap lightly. Remember that a severe jar will be carried to the defective part through the chassis even if you are probing some distance away.

Shields should be shaken or twisted gently to see if they are making good electrical contact with the chassis. This test may also disclose a short between the shield and the device within it. If you wish, pull on the leads going to a suspected joint, or push the joint with a wooden stick—but going over all suspected joints with a hot soldering iron is perhaps the quickest procedure. Continue to operate the receiver for some time after thumping on parts or resoldering, as you may have only temporarily cleared up the trouble.

**Noise in Signal Circuits.** Occasionally the noise-producing defect

may be in a signal circuit—for example, a trimmer used to tune an i.f. transformer secondary may be partly shorted or may short at intervals. There is no current flow through such a circuit when signals are not being received, except that caused by between-station atmospheric and residual noises, so the defect usually will be heard only with a station tuned in. Thus, when you remove the ground and antenna leads, the noise may disappear. This may lead you to blame the antenna rather than a set defect.

A test receiver will keep you from making this error, since it will show that the set, rather than the antenna, is defective. If you have no test set but suspect the receiver, you might try another aerial. Better yet, feed the full *unmodulated* output of a signal generator (tuned to the receiver dial setting) into the aerial and ground posts. If noise is then heard, an r.f. defect is indicated; if modulation of a signal generator is necessary before the noise appears, the trouble may be in the a.f. section, or the sounds from the loudspeaker are vibrating some mechanically poor joint, which may be anywhere in the radio. You can then localize the noisy stage either by using a signal tracer or by moving the signal generator along from stage to stage.

# Intermittent Reception

A radio may be described as intermittent if it operates normally *part* of the time, but stops, cuts down in volume, squeals, gets noisy, distorts, or hums *some* of the time.

The intermittent receiver has a bad name among servicemen, for, at one time or another, most servicemen have been stumped by some stubborn case which refused to yield to their best efforts, or which consumed hours of time for which they couldn't collect.

Naturally there is always a definite cause for any intermittent action, but the difficulty lies in the fact that while the receiver is playing normally the defect does not exist, and no amount of testing will disclose it. Only when the receiver is in an intermittent condition is the defect present. At this time tests can lead to the defective part, but disturbing the receiver in any way, even by attempting to take voltage measurements,

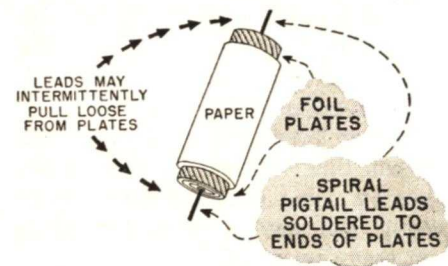

FIG. 9. Paper condensers are a common source of intermittent reception.

may cause it to snap back and play properly. You may then have to wait hours — even days — for the trouble to show up again.

Thanks to the modern methods of servicing, much of the uncertainty of dealing with intermittents has been eliminated. The most stubborn case of intermittency can be licked by a combination of searching for surface defects, effect-to-cause reasoning, and

section and stage isolation. Modern equipment even allows the serviceman to do other work while waiting for the intermittent action to make its appearance.

## INTERMITTENT DEFECTS

You know already the ways in which parts may become defective—how paper condensers may open or short, how electrolytics may open, leak, or develop a high power factor, how interelectrode leakage may take place in tubes, etc. Now we will see how some of these defects can occur intermittently.

**Paper Condensers.** The internal construction of a paper condenser is shown in Fig. 9. The leads of the condenser are ordinary bare wires whose ends have been curled into a loop. The loop is soldered to the foil if tinfoil is used. With aluminum foil, the loop is filled with solder, making a solder disc, and then pressed into the soft face of the exposed foil to give an electrical contact. The foil may be crimped around the solder disc. Both ends of the condenser are then dipped in a wax which, on hardening, holds the discs in contact with the foil plates. When we say that a condenser has opened, we mean that one of the discs has pulled away from its foil plate. The effect is the same as if the condenser lead were cut or a resistance were inserted between the disc and the condenser plate.

Now, suppose one of the flat discs is barely in contact with the foil, instead of being completely pulled away from it. Slight jars or electrical surges may make the connection open and close. For example, the disc may be in contact with the foil at a single point, and a signal surge may cause

enough current to flow to burn out the connection. Another voltage surge may start an arc or may cause the disc to again come in contact with the foil and the cycle of troublesome events may be repeated.

Another possibility is that the condenser may be open at the disc-foil connection, and a signal surge may

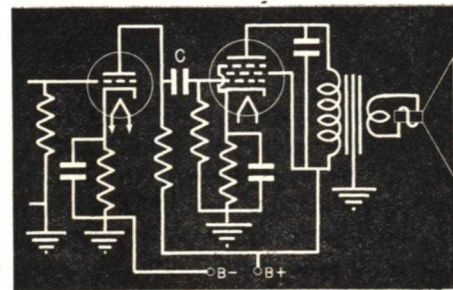

FIG. 10. A typical resistance-coupled audio stage.

increase the voltage between the foil and the disc enough to allow an arc to form between these two points. This arc will be self-sustaining and will complete the connection, thus restoring the condenser to operation. If the arc fails for any reason, the condenser will again be open.

► Notice—either of the conditions just described would cause noise, rather than intermittent reception, if it occurred frequently enough. For example, if one of the connections to coupling condenser *C* in Fig. 10 were to open, then close again in a few seconds, the signal level will jump up and down, and you would diagnose the condition as intermittent reception. But if exactly the same effect occurred much more frequently—say several hundred times a second—the set would be noisy. Similarly, other rapid open-and-closing actions will produce noise, while a slower tempo will cause another form of intermittent reception. For instance, if the screen grid by-pass opens and closes

at relatively long intervals of time, intermittent oscillation results; if the same action occurs rapidly, noise is produced.

Thus, you are not entering brand-new territory when you search for the sources of intermittent reception. The intermittent defect that produces intermittent noise, hum, oscillation, distortion, or decreases in volume would produce these same conditions continuously if the defect were continuous. You have already learned which defects may cause *continuous* noise, hum, etc.; now, all you need learn is which of these defects can occur *intermittently* and you will be prepared to solve the most puzzling cases of intermittent reception. Let's see, briefly, what these defects may be.

**Electrolytic Condensers.** Dry electrolytics normally do not open or short intermittently—in them, such defects are permanent. However, some dry electrolytics are anchored



Leakage through the case to the mounting bracket may cause intermittent hum.

to the chassis by a metal clamp around the condenser housing, and leakage sometimes develops between the condenser and the chassis through the paper housing. The trouble may be intermittent, disappearing when the paper dries out after several hours of operation, and reappearing when the receiver has not operated for some time or when the air is particularly humid.

► Wet electrolytics sometimes have intermittent defects. A conductive

sediment may form and settle to the bottom of the container, causing leakage. This deposit may dissolve, thus temporarily eliminating the leakage path, after receiver operation has heated the electrolyte. Suspect this condition if you see a white deposit around the vent of a wet electrolytic.

**Other Condensers.** Tuning condensers may intermittently short because of dust or metal particles between the plates. Midget-sized condensers may short due to bent plates, as even a small vibration can cause the plates to touch due to the close spacing. Watch for broken leads to the condenser gang, as it moves considerably during tuning. If the electrical connection is made to the stators via the bolts securing them, corrosion on the bolt threads may cause a varying resistance in the connection. Dirt or improper spring tension in wiping contacts may cause a varying resistance between the rotors and the condenser frame.

Fixed mica condensers do not ordinarily have intermittent defects. However, intermittent changes in capacity or short circuits may be caused in trimmer condensers by cracked mica or fatigue of the spring metal rotor plates.

**Volume Controls.** Volume controls frequently have carbon resistor strips which are pitted, or the carbon may have flaked off. Only a small portion of the slider may be in contact with the strip, so may be thrown out of contact by the slightest mechanical jar or by a current surge which burns out the section which the slider touches. Also, high-resistance joints between the slider contact and its terminal on the case may intermittently open the slider arm circuit. Troubles caused by burned or pitted strips are most apt to occur in controls through which d.c. flows, as in

the diode load circuit or in a grid circuit having grid currents.

**Tubes.** Tubes are one of the most prominent causes of intermittent reception. Quite often electrodes will expand with heat and touch other electrodes, thus causing intermittent shorts. Also, the filament may expand and break. This interrupts the current flow; the filament then cools, the broken ends come together, and current flow resumes. This is sure to cause intermittent reception.

Gas in a tube will often cause erratic operation, as will a faulty cathode. Sometimes particularly active emission spots appear on a cathode; as these lose their excess emission ability, the gain in the tube will vary.

**Resistors.** Wire-wound resistors may have intermittent opens at their terminal connections — particularly metal-clad “candohm” resistors. Heavy current through molded carbon resistors may cause uneven resistance distribution, resulting in varying resistance values and erratic current flow. This condition may not occur until the receiver has been in operation for some time and the resistor has become thoroughly heated. The carbon rod in a resistor of this type may sometimes break, causing an intermittent open.

**Coils.** Electrolysis in coil windings that carry d.c.—particularly the primary windings of i.f. transformers, a.f. transformers and oscillator coils—may cause intermittent opens. Frequently the form on which an r.f. coil is wound will expand with heat, snap a lead from the coil to its terminal lug, and so produce an intermittent contact.

**Connections.** Connections made to the chassis through rivets frequently work loose or corrode and so cause intermittent contacts. A poor contact may also develop between the chassis

and the can of a grounded electrolytic. On the other hand, if the condenser is insulated from the chassis by a fiber washer, leakage may develop across the washer and allow the condenser case (condenser negative terminal) to short to the chassis intermittently.

**Vibration.** Vibration is very apt to cause intermittent operation, particularly in car and portable receivers. Many parts in these sets may be mounted on rubber feet to reduce mechanical shock; even so, leads to such parts may be snapped and the broken ends may make intermittent contact.

**Mice.** Mice will frequently nest in radio receivers. They may drag in paper scraps, chew the insulation on wires, eat the cone of the loudspeaker, or wet insulation or some vital part and cause almost any effect on the receiver.

**General.** We have given the more common intermittent defects. There are, of course, many more. There are also some defects which almost never contribute to intermittent difficulties. A by-pass condenser is more commonly open intermittently than it is intermittently shorted, yet this last

possibility should be kept in mind. The power transformer rarely is intermittently defective, nor are properly soldered connections. (However, servicemen frequently introduce intermittent troubles by poor soldering; examine all connections carefully if you find a wire loose in a radio after the set has been serviced by some one else.)

Now for some general rules: All intermittents respond to some stimulus—a voltage surge, a mechanical shock or a thermostatic expansion or contraction—which opens and closes a circuit.

Tapping the radio will show whether mechanical shocks cause the trouble. Troubles due to heat are usually very regular; the radio is on and off at rather definite time intervals, depending on the part or circuit containing the defect. A short time interval usually indicates a defective tube or part carrying a high current. If the time period between cut-off intervals is rather long, you usually have trouble in a circuit carrying small amounts of current in which less heat develops, or trouble in some large slow-heating part.

---

## External Intermittent Troubles

Relatively few parts can cause intermittent distortion, intermittent hum, etc. However, literally hundreds of things might cause an intermittently dead receiver or one in which the volume cuts to a low value and then snaps back. For such complaints, a professional means of localization is definitely required. We will deal with this kind of intermittent reception first.

### HOW TO DETERMINE THE COMPLAINT

When a customer complains of intermittent reception, you should satisfy yourself that trouble actually exists, and that it occurs with sufficient regularity, before you accept the job. Here are some highly important questions you should ask:

1. *Does the receiver fade only on distant stations or on all stations?*

2. Does the fading occur only at night, only in the daytime or both?

3. How long must the receiver be on before the fading occurs?

4. Does the fading occur at regular or irregular intervals, and about how long a time elapses between the cut-on-cut-off intervals?

► If the fading occurs on all stations, you can assume that something is wrong with the radio or the installation. Should the customer say that locals come in all right and that fading is on distant stations, the action is normal. It is caused by the sky wave (on which distant reception is obtained) fading in and out as the height of the Heaviside layer shifts. Complaints on this score are more prevalent during the fall and winter months when long-distance reception on the broadcast band improves in the northern hemisphere. Then, more distant stations can be heard during favorable periods, but they are subject to more fading.

You won't have many complaints of this kind with customers who have had their receivers a year or longer. However, many people buy new radios around Christmas. They are unfamiliar with the characteristics of the set and may happen to encounter a favorable night or two before the fading becomes noticeable. At once they become alarmed.

When the normal summertime drop-off in reception of distant stations occurs, you may again encounter some customer complaints which are caused entirely by normal conditions rather than by the receiver.

► If the fading takes place only at night, it is probably caused by fading of the sky wave, unless nearby locals fade. However, stations normally considered to be locals may fade at night if the transmitting antenna is more than ten miles away and if the sta-

tion operates near the high-frequency end of the broadcast band.

Fading in the daytime generally indicates a receiver defect, for then reception is by ground waves which are constant in intensity. Bear in mind, however, that if the receiver fades and the volume remains weak for definite periods of the day or night, line voltage fluctuations rather than a receiver defect may be the cause.

► Be careful to learn from the customer how long the receiver is actually operated. You may find that he rarely turns the set on for more than a few minutes in the daytime, and so may not notice that the fading does occur in the daytime as well as in the night, or vice versa.

**Line Voltage Fluctuations.** If you suspect line voltage variations (which are most apt to occur in industrial districts), attach a voltmeter to the power outlet and watch it for a short time. Also watch lights for blinking or varying brilliancy. If line voltage fluctuations occur at the same time as the fading, you have tracked down the source of trouble.

If the line voltage variations appear to be the source of trouble, you might take the matter up with the local power company as they will frequently cooperate by correcting their systems.

Line voltage regulators are available which will sometimes prove helpful. Essentially, these are resistances which change radically in value with changes in current flow. One of them in series with the receiver power cord will usually correct the rises in line voltage, but it cannot correct for large voltage drops.

**How Often?** Since some intermittent conditions will not start for a half hour or an hour after the receiver is turned on, to save time you should arrange to have such a set operated

long enough for the intermittent condition to occur before you arrive.

► Should the customer tell you that the receiver cuts off only once or twice a day or even more infrequently, and comes back to normal almost immediately, the trouble has not progressed far enough to repair. You should tell the customer to continue to use his receiver, calling you when the trouble becomes more frequent or when the set stops entirely. Explain that this will result in a less costly job and that the chances of anything else in the receiver being damaged are remote. Point out that it is a difficult, time-consuming process to repair the set in its present condition, so it is to his best interest to postpone repairs for a time.

Now, let's go through the servicing procedure you should follow if the receiver fades with sufficient regularity for you to accept the job.

#### INSTALLATION DEFECTS

Your first step, of course, is to turn the receiver on and confirm the complaint. When the intermittent condition shows up, or while you are waiting for it to occur, you should make sure the defect is not in the installation. The installation can make the receiver go dead or fade intermittently, or produce intermittent noise or intermittent modulation hum. On the other hand, it cannot normally cause intermittent distortion, steady hum, or oscillation.

A poor antenna or ground is a common cause of intermittent reception. For example, if a set playing at a normal level suddenly becomes quite loud when some appliance or light is turned on, a poor ground on the receiver is to blame. The set is depending on the power line for a ground, and the chassis happens to be coupled to the ungrounded side of

the line. Connecting lights or other devices across the power line reduces the impedance of the ground path and so changes the level of the signal fed to the input of the receiver. On the other hand, should the signal level drop when an appliance or light is turned on, the set is depending on stray coupling to the ungrounded side of the line for an antenna. The light reduces the impedance to ground, thus reducing the signal level.

A.C. sets using a power transformer are more subject to this form of trouble than a.c.-d.c. sets, as a.c.-d.c. sets are connected directly to the line while a.c. sets are isolated from it by a transformer, so stray capacity or inductance provides the coupling. Often a cure may be effected by connecting .01-mfd., 600-volt condensers from *each side* of the power transformer primary to the chassis. However, a better antenna and a good ground are the best cures.

In these cases, notice that turning a switch on or off causes a change in volume, *but the volume then remains steady until a switch is again operated.* Should turning on or off switches cause an intermittent change, or should snapping a switch on and off clear up the trouble, the receiver is intermittent in such a way that it is subject to electrical shocks.

► Checking the installation further, inspect the antenna-ground system for mechanical failures which could cause either opens or shorts. Check it just as suggested earlier in this lesson for noise. Check the flat top to see if it touches anything or if it can sway in the wind and so short to some object. Shake the lead-in vigorously to see if this action causes the intermittent or any noise to appear. Frayed insulation on the lead-in will often permit a short to occur when wind moves the lead-in about.

Check the connections to the lightning arrester and lead-in strip. See if the latter can short on the window weather-stripping. Trace the lead-in right up to its point of connection to the receiver; at the set, look for loose strands of lead-in wire shorting to the chassis. Investigate all connections covered by tape to make sure none are bad. Any one of these little things may cause intermittent reception, and no amount of work on the chassis at your shop will locate the trouble.

The surest way to check the antenna-ground system is to connect your own test receiver to the system in place of the customer's radio. If the customer's complaint shows up in the test receiver while you make your inspection, you know that the installation rather than the customer's radio is at fault.

► If a shielded antenna lead is used, find out if rain always accompanies the trouble. If so, rain water may be

getting inside the shield and shorting the antenna wire lead.\* Since poor ground connections frequently cause trouble, check the ground clamp carefully—make sure a clamp is used if the ground connection is made to a pipe. A cold water pipe makes the best ground; make the connection near the point where the pipe enters the home if possible. Avoid gas pipes for two reasons—it is against fire regulations to use one as a ground, and the sealing compound in the joints has considerable resistance, thus reducing the effectiveness of the ground system. The hot water heating system does not always make a good ground either. ► Bad connections, loose appliances and loose wiring at outlet plates cause intermittents. Check for such conditions by connecting a low-wattage bulb to the radio outlet in place of the receiver and watching for flickering.

\* This trouble frequently occurs in auto radio installations.

## Localizing Intermittent Troubles

Let us presume we still have a case where the set is intermittently dead or where the volume cuts to a low value and then snaps back. If nothing is wrong with the installation, you must go to work on the receiver. However, before removing the chassis and speaker from the cabinet, make a check for surface defects. Look in the back of the cabinet. Make sure that the tubes, shields and any chassis or speaker plugs used are firmly in place, and that the top cap connectors clasp the top cap studs on the tubes tightly. If the lead to the top cap of a shielded tube comes from the chassis, make sure the shield has not cut the lead insulation and created a short. If the lead comes through the

chassis inside the tube shield, see that it remains inside the shield; otherwise, keep it outside. Gently shake any cables or wires in the cabinet; any intermittent effect produced shows a loose connection or broken lead.

Test the tubes. Tap each tube as it is checked and watch for intermittent flashes of the short indicator or intermittent meter readings. Intermittent troubles won't always show up in a tube tester, so remember that this test does not eliminate the tubes as suspects.

► If you find no surface defects, take the set to your shop. Curing intermittent reception calls for tests which may appear quite aimless to the receiver owner, so it is psychologically

better to take the set away. Further, you need room to work comfortably, you should test the receiver carefully by operating for some time after the repair and, often, you'll need shop equipment to localize the trouble.

► Once you get the receiver on the workbench, set it up for normal operation. If the radio has a tuning indicator, see whether it is affected when intermittent reception develops. Should the tuning indicator change when the volume drops or the set goes dead, you can be fairly sure that the trouble is between the antenna terminal and the second detector (although occasionally it may be in the power supply). On the other hand, if the tuning indicator does not vary, the audio section of the receiver is faulty.

Next, notice whether the residual or background noise level increases when fading occurs. An increase in the residual noise level usually means a defect in the oscillator, the r.f. stage or the input circuit, which reduces the input signal so the first detector noise level is more prominent.

### BRUTE-FORCE SERVICING

Intermittent reception is one of the few troubles where the "brute-force" method pays dividends. Remember, it may take some time for the set to act up; anything you can do which will produce defective operation and localize the trouble at the same time is definitely worth while. However, don't let your methods fall into a "try everything," aimless probing and testing. Limit yourself to no more than five minutes of probing.

Now, let's see how you can use "brute-force" and effect-to-cause reasoning at the same time.

You have already learned the general causes of intermittent action. The most common is the joint which opens

and closes under mechanical or electrical stress, and here's the point on which this first five minutes of testing depends: *If you can disturb the bad joint so that you can make the set cut off and on at will, your problem is solved.*

How can you disturb defective joints? Easily—just pull on leads, wiggle parts, thump tubes and resistors, or apply mechanical pressure to joints. Let's see how this should be done.

**Checking Controls.** First, check the various controls. The volume control can be checked by rotating it over its full range. If noise is produced, the control is badly worn and is a possible cause of the intermittent condition.

Intermittency caused by poor contacts in wave-band, manual push-button or tone-control switches can be located by wiggling the switch knob or button back and forth (but not moving it enough to change from one position to another). The switch is defective if you can make the intermittency appear and disappear at will. Cleaning the contacts and bending them to make better contact will often clear up this trouble. Sometimes you must install a new switch.

Noise when the tuning condenser gang is rotated indicates shorting particles between the plates; perhaps dust or dirt is lodged there or plating has peeled off the plates. Poor wiping contacts may also be to blame. Tighten them by bending the springs.

► While the set is right-side up, check the tube socket contacts by wiggling each tube to make it move around a slight amount in its socket. If a tube is too hot to handle, hold it with a heavy cloth or a kitchen pot-holder.

Tubes may also have internal shorts and intermittent contacts at the points where the electrodes are welded to

their leads. These may be found by snapping the tube vigorously with your finger. When any doubt exists, try another tube.

Of course, you must be careful not to jar surrounding parts when wiggling or thumping tubes. A mechanical shock may travel through the chassis to another part, cause the intermittent to act up, and lead you to believe the tube is faulty. If a new tube acts just like the old one, the trouble is probably somewhere else.

► Now let's check underneath the radio. You will need a pair of long-nose pliers and some sort of an insulated probing tool. An ordinary test lead can be used in a pinch. Some servicemen use a pencil; however, since pencil lead is conductive and so may permit you to be shocked, we suggest you make up a tool similar to the one shown in Fig. 11 instead.

This can be a hard rubber or bakelite rod or a wooden dowel, from  $\frac{1}{4}$  to  $\frac{3}{8}$  inch in diameter and about 8 inches long. Cut one end off square and file the other end to a point resembling a screwdriver blade. Cut a notch in the square end. If a wooden dowel is used, it should be varnished or shellacked (not painted) so it will not absorb moisture.

With a tool of this kind, you can pull and push on parts at will without any danger of shocks.

**Avoiding Shocks.** While we are talking about shocks, let's take a moment to see how you can avoid getting them when you work on a live receiver.

To get a shock, you must touch two points which are at different potentials. Therefore, use only one hand, if possible, when you probe in a live receiver; this will make touching two points less likely. Further, don't lean on the radio, and make sure it is firmly supported. You will uncon-

sciously grab for a receiver that is falling over and may get "bit."

► Sometimes, especially when working on an a.c.-d.c. receiver, you will get a shock when you touch the chassis. This may happen if the receiver power plug is inserted in such a way as to connect the chassis to the ungrounded side of the power line (there is often a direct connection between the chassis and one power cord lead). Then, 110 volts a.c. will exist between the chassis and earth, and you'll get a shock if you touch the chassis while you're grounded. If you reverse the power plug at the wall outlet, the chassis will be at earth potential and no shock will result from touching it. However, it's best not to be grounded, since you can't tell whether the chassis is "hot" just by looking at it.

Also, in some a.c. receivers, a condenser is connected from one side of the power transformer primary to the chassis. If the power plug is inserted into its socket in such a way as to connect the chassis to the ungrounded side of the line through the condenser, you'll get a small shock if you are grounded and touch the chassis. If the chassis is connected to an earth ground with a ground wire, you can touch it without fear of being shocked. (There may be a spark when you attach the ground wire to the chassis, but it will not harm you.)

► Your best single precaution against shocks is to insulate yourself from the earth. Don't stand on a concrete floor (an excellent ground) unless you are wearing dry rubber-soled shoes. The best insulation is dry wood—so sit on a wooden stool or, if you must work in a place with a cement floor, put a wooden flooring in around your workbench. Don't just lay boards down on the concrete—they will absorb moisture and soon become con-

ductive. Space the floor up from the concrete by strips of wood.

► You can insulate your tools with rubber tape, or buy properly insulated electrician's tools. However, tape will eventually rot and get sticky, while factory-insulated tools may make you careless—which means you'll be almost sure to get a heavy shock some day.

► Be careful how you touch the case of a metal-clad electrolytic condenser mounted on top of a chassis. Remember that the can is the negative terminal of the electrolytic condenser and, if the can is insulated from the chassis, 100 volts or more may exist between



FIG. 11. This home-made tool is helpful when pulling on wires and moving parts.

the can and chassis. If you see a fiber washer between the base of the condenser and the chassis, don't touch the condenser case and chassis at the same time. If the condenser case is in electrical contact with the chassis, both can be touched at the same time without danger of getting a shock.

The important thing to remember is that to get shocked you must make your body part of a complete electrical circuit. Remember this always and you need never worry about getting shocked.

**Under-Chassis Defects.** If you have localized the trouble to the audio or the r.f. end of the receiver by watching a tuning meter, tune the set to a station and gently wiggle the paper by-pass condensers and the coupling condensers in the suspected section with a pair of long-nose pliers. If the intermittency occurs when you do this to one of the condensers, this

condenser is at fault and should be replaced. Be careful not to short terminals together with the long-nose pliers.

Rather than waste a lot of time trying to identify the condensers when they are mounted on terminal strips, wiggle all of them. Be sure you wiggle them gently. If you are too vigorous, you are liable to pull loose a good condenser.

If the condensers are mounted so that you cannot grasp them easily with the pliers, use the insulated probing tool to move them.

► One manufacturer encloses his condensers in black bakelite cases which are bolted to the chassis. The condenser leads are brought up through eyelets and soldered to mounting lugs. Check the connections to the plates of such a condenser by probing through the eyelet with a sharp probe and gently lifting up on the wire connected to the lug. (The hooked end of a small crochet needle is ideal for this purpose.) If movement of this wire cuts out the receiver, you have found the defective part. Remember,

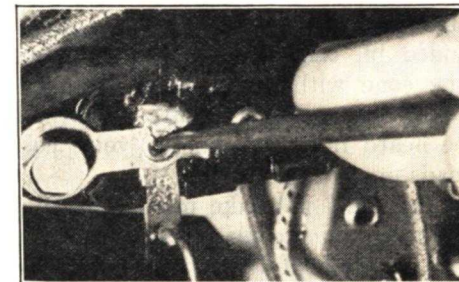

Probing in the eyelet of a bakelite-enclosed condenser to see if disturbing the lead will cause the intermittent reception condition to appear.

be gentle—internal condenser connections are so delicate that undue stress may ruin a good condenser.

► Check connections by pulling on leads. If the receiver cuts on and off when you do this, applying a hot soldering iron to the joint in question

should clear up the trouble. Make certain that excess solder on the joint is not shorting to the chassis or to an adjacent connection.

► Ordinary resistors seldom cause trouble, but should be tapped lightly with your probing tool to see if intermittent action can be caused. The metal-clad candohm resistor, which is usually bolted to the chassis wall, frequently develops poor connections at its taps and ends. Check for this source of trouble by wiggling all terminals with a pair of pliers.

Tap exposed coil forms with the probing tool and move their lugs back and forth a *slight* amount with long-nose pliers. This will check for broken wires near the terminal lugs.

► Sometimes jarring shielded parts mounted on the chassis will show a partial open or short in the enclosed part. This is particularly true of i.f. transformers and, to a lesser extent, of a.f. transformers and chokes.

► The leads on loudspeaker voice coils sometimes become loose at their terminals, perhaps only during maximum movements of the cone. With the set turned on but with no signals tuned in, check for this by moving the cone with your hands, listening for a characteristic "plop" which will be heard if tension on the voice coil leads opens the circuit.

► It should not take more than five minutes to make these tests, and they will solve about 75% of the intermittent cases you encounter. However, effect-to-cause reasoning and signal-tracing equipment—and often plenty of patience!—are necessary to solve the remaining 25% of really obscure cases.

## SECTION AND STAGE ISOLATION

We have already mentioned how the receiver tuning indicator may localize the defective section. If,

when fading occurs, the indicator shows a loss in the strength of the signal delivered to the second detector (or a.v.c. diode), the trouble is either between this point and the antenna or in the power supply. If the tuning indicator is unaffected, the trouble must be between the second detector (or a.v.c. stage) and the loudspeaker cone. These observations at once tell which section is at fault.

If the receiver does not have a tuning indicator, you can connect a high-sensitivity d.c. voltmeter or a d.c. type vacuum tube voltmeter across the a.v.c. circuit and get the same indication.

**Signal Tracing.** Should you have a signal tracer, however, the problem is vastly simplified. The average signal tracer contains a section, known as an r.f.-i.f. channel, which is capable of tuning over the i.f. and the broadcast band. It may also contain a less sensitive section, called an oscillator channel, which will cover the oscillator and broadcast range of the receiver, also an a.f. channel, and perhaps a d.c. vacuum tube voltmeter. A typical instrument of this type is shown in Fig. 12. The advantage of this type of signal tracer is the fact that the signal progress can be observed at a number of points simultaneously. Let us see how you can use an outfit of this sort to check the typical a.c.-d.c. receiver shown in Fig. 13.

► First, let's make connections so as to use all the channels at one time. We will need the *r.f.-i.f. channel* for the i.f. stages, so let's connect the *oscillator channel* to point 2 to check the constancy of the r.f. signal delivered by the 12SK7 tube.

The *r.f.-i.f. channel* can be connected to point 4 to check the mixer-oscillator.

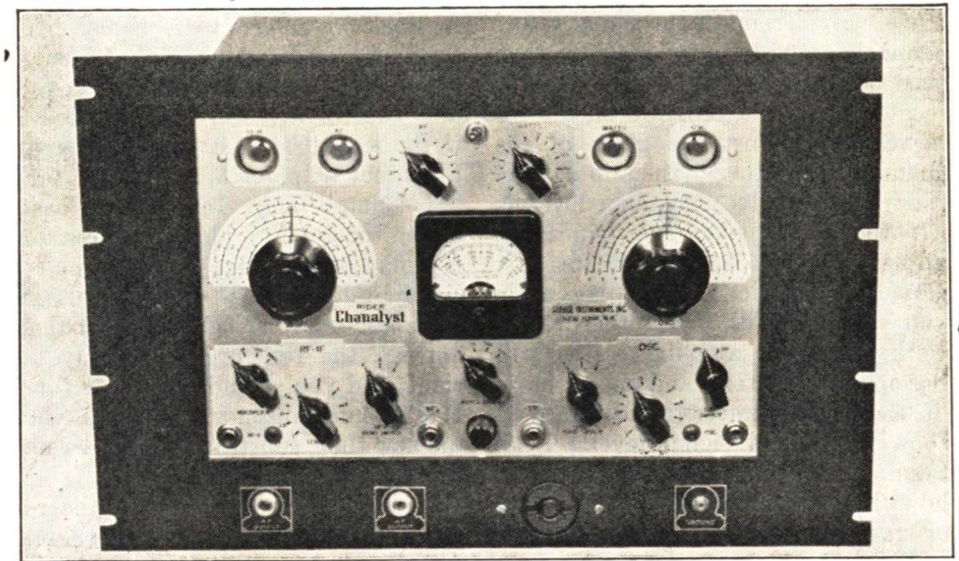

FIG. 12. A multi-channel signal tracer. Tuning eye tubes act as indicators, except for the d.c. type v.t.v.m., which uses the meter. This instrument has a tunable r.f.-i.f. channel; a tunable r.f. channel (called the "oscillator" channel); an audio channel; the d.c. type v.t.v.m., and a wattage indicator. By using all the channels (except the wattage indicator) at one time, a radio can be broken into four sections, making it possible to localize the defect quickly.

The *d.c. type v.t.v.m.* can be connected to test either the a.v.c. or the power supply. The a.v.c. can be checked at point 12 (at the volume control) if the meter does not by-pass the audio signal too much; otherwise, point 13 is preferable. The power supply can be checked at point 14.

The *a.f. channel* can be connected to point 9 (the 35L6 input) to check the progress of the signal from the volume control to the input of the 35L6 power tube. (The loudspeaker output would indicate conditions from point 9 onward, as any change not indicated by the channel at 9 must be due to an output stage or speaker defect.)

► The test probes usually end in peewee clips which may be clamped onto a terminal or tube socket lug. However, the probes generally fall off if you try to turn the chassis right-side up. If it is necessary to turn the

chassis over, you'll save time by soldering wire leads to the points where you are checking. You can then clip the signal tracer probes to the ends of these wires and turn the chassis over without disturbing the connections.

► You must make a ground return connection to the receiver. In standard a.c. sets, the ground lead of your signal tracer can be clipped to the set chassis. However, in a.c.-d.c. receivers (like that in Fig. 13) where there is no electrical connection to the chassis, you must find the B-circuit, particularly to measure a.v.c. and power supply voltages. Point 15, or any other point on the B— bus or lead, may be used for this connection. Many servicemen use the set side of the ON-OFF switch as a convenient connecting point.

Here's the general procedure to follow to isolate the defective section or



stage. First, connect the signal tracer channels properly to the receiver, then turn on the set and the test instrument. Tune in a program on the receiver and adjust the gains of the channels until their visual indicators show some easily remembered value. (If they are magic eye indicators, adjust them so the eyes are just closed.) Then let the set play while you take care of your other bench work. Sooner or later the receiver will become intermittent, and one or more of the signal tracer indicators will show a changed signal level. Let's take a few practical examples to see how this will point out which section or stage is defective.

**Example 1.** Let's start with connections at points 2, 4, 9 and 14. Suppose that the signal level remains normal at points 2 and 4, and that the power supply at 14 remains constant, while the signal level at point 9 decreases. This is definite proof that the cause of the trouble lies between points 12 and 9.

How can you be sure that the trouble is between points 12 and 9 and not between points 4 and 12? The steady readings at points 2 and 4 are proof. You see, a defect between points 4 and 12 would drop the signal input to the second detector. The a.v.c. voltage would then drop, permitting an increase in the gain of the r.f. and converter tubes, and the channels connected at points 2 and 4 would show a larger signal. Since, in our example, the signal level remains constant at points 2 and 4, no defect exists between 4 and 12.

To localize further, remove the a.f. probe from point 9 and touch it to point 8. If the signal indicated here is much greater than at point 9,  $C_{21}$  is open.

If the signal is still weak, move the probe to the junction of  $C_{20}$  and  $R_{10}$ .

A weak or intermittent signal here shows  $C_{20}$  is defective or the slider is not making a good contact on the volume control  $R_9$ . On the other hand, if the signal is as strong or stronger than that at point 8, the 12SQ7 tube is not amplifying. In the latter case, either the tube or plate load resistor  $R_{11}$  may be defective. Check the resistor by measuring the plate voltage. If it is normal or slightly higher than normal, the resistor is probably all right, and you should try a new tube. If the intermittency continues with the new tube, substitute a new resistor for  $R_{11}$ .

It is entirely possible that the receiver may snap back to full volume while you are changing the signal tracer connection or while some other test is being made. If this happens, make the new signal tracer connection to the point where the probe was at the time the volume snapped back, readjust the channel gain for the new point, and go about your other business until the intermittent appears again, then continue to move back, step by step. In this way you can gradually narrow your search until part substitution becomes feasible.

**Example 2.** Suppose the signal level indicated at points 2 and 4 increases, while that at point 9 decreases, and the supply voltage (point 14) remains constant. As you learned in the first example, this indicates trouble between terminals 4 and 12. Shift the d.c. type v.t.v.m. from point 14 to either 12 or 13; if you find the a.v.c. voltage decreases when the trouble occurs, you have confirmed this diagnosis.

► Now remove the r.f.-i.f. probe from terminal 4 and move it to point 5, the control grid of the i.f. tube. The signal level should be at least half the value it was at point 4. If it is considerably lower, either transformer  $T_2$ ,

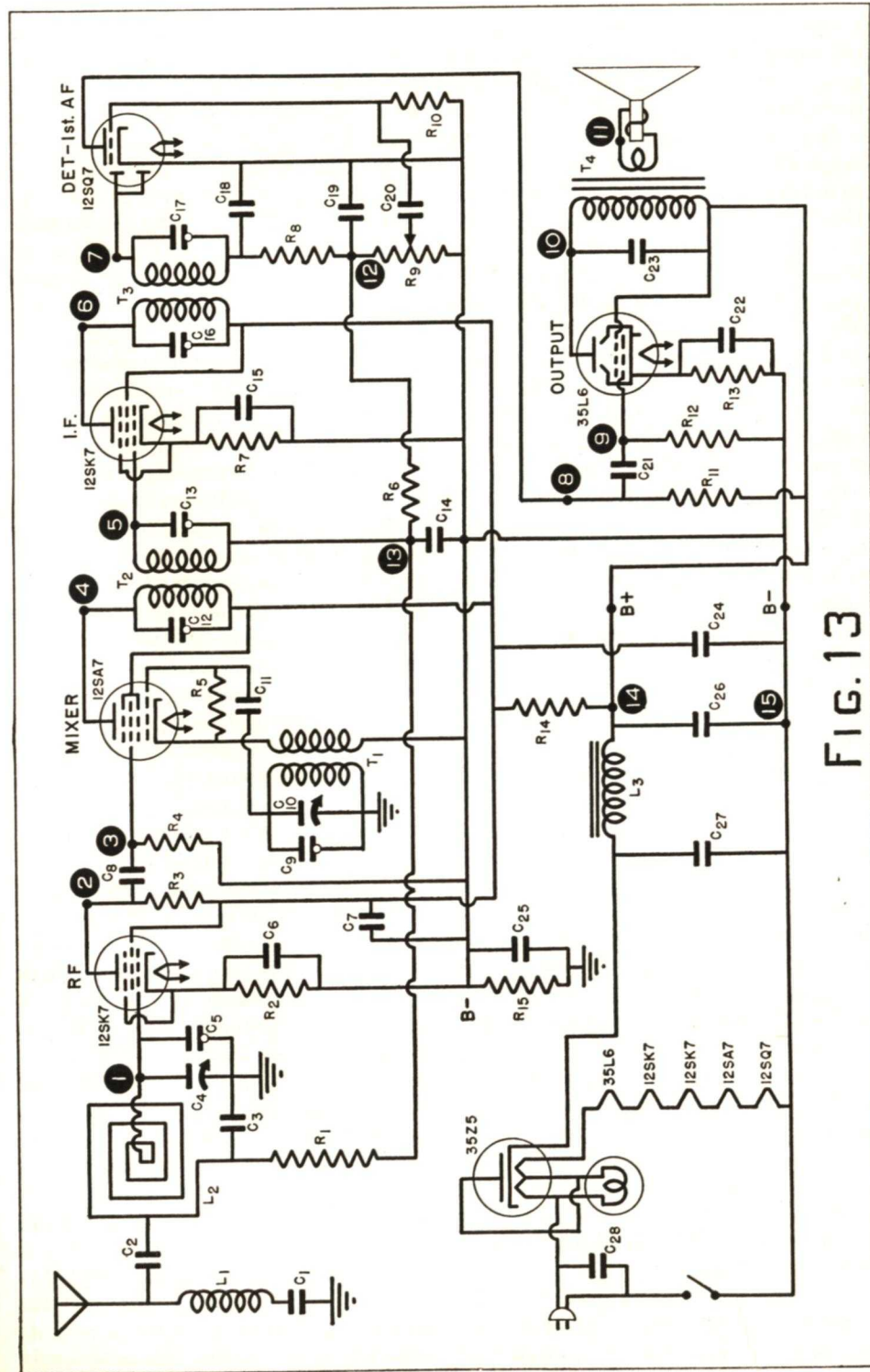

FIG. 13

or condenser  $C_{14}$  is defective. Hold the probe across  $C_{14}$ . You should *not* get a signal here if the condenser is working.

If you prefer, shunt  $C_{14}$  with a test condenser. The signal will jump up to normal at point 5 if  $C_{14}$  is defective. However, remember that charging this condenser may provide an electrical shock, restoring operation anyway. Leave it temporarily connected and see if the trouble recurs before making a permanent repair.

► Should the signal at the i.f. grid be normal, move to the plate of the i.f. tube, point 6. If there is no gain in signal, the i.f. tube is defective, the trimmer  $C_{16}$  is shorted, the primary of  $T_3$  is defective, or possibly condenser  $C_{15}$  has opened. Try another tube. If this does not clear up the trouble, move your signal tracer probe to the cathode of the i.f. tube. You should *not* be able to find an i.f. signal across  $R_7$ ; if you do, condenser  $C_{15}$  is defective and should be replaced. Should this condenser be normal,  $C_{16}$  is the remaining suspect. Disconnect it and test it with an ohmmeter.

In an a.c. radio using a power transformer, the screen grid may be supplied through a series resistor and will be by-passed to ground or chassis by a condenser. A defect in either of these parts could easily cause a loss of gain in the affected stage. Of course, there are no such parts in this a.c.-d.c. set.

Should you find the signal normal at the plate of the i.f. tube, move to the second detector diode plate, point 7. A large drop in signal (to less than one half) from the level found at point 6 indicates something wrong with the i.f. transformer  $T_3$  or with condenser  $C_{18}$ .

You can check  $C_{18}$  by taking a reading directly across it with the signal tracer probe at the junction of

$R_8$  and  $C_{18}$ . You should get little r.f. signal at this point. If you find a large signal, replace  $C_{18}$ .

► A normal signal at 7 leaves the second detector and its circuit as the remaining sources of trouble, so the defective stage is localized.

**Example 3.** Now let's see what to do if the signal fades at points 4 and 9, the supply voltage at 14 remains constant (or if the v.t.v.m. is connected to 13, the a.v.c. voltage drops), but the signal remains constant (or increases) at 2. This shows trouble in the 12SA7 stage; the mixer stage may be at fault or the oscillator may have failed. Check the input to the mixer by moving the oscillator channel from 2 to 3. If the signal is considerably less than at 2, condenser  $C_8$  is open; if not, try another 12SA7 tube.

► If the set still does not perform, the oscillator circuit is at fault. Check it by placing the oscillator channel probe on the stator of the oscillator tuning condenser and tuning the channel to a frequency equal to the receiver dial setting plus the amount of the i.f. The oscillator signal, if present, will be picked up and indicated by this channel.

If there is no oscillator signal, check the oscillator coil for continuity, go over all connections in the oscillator circuit with a hot soldering iron, check the tuning condenser and its trimmer, try another resistor in place of  $R_5$ , replace  $C_{11}$ , and finally, install a new oscillator coil if nothing else has remedied the trouble.

**Example 4.** Returning to our connections at 2, 4 and 9, suppose all the readings drop simultaneously—what is indicated? The answer may depend on whether the d.c. type v.t.v.m. is connected to the power supply (14) or to the a.v.c. network (13). If the d.c. meter is connected to 14 and its reading goes down simultaneously

with the others when the fade occurs, there is obviously a defect in the power supply (which, of course, affects every stage in the radio).

But if the meter is connected to the a.v.c. (13) and all readings drop, you can't tell whether the defect is in the radio input or in the power supply. In such a case, you must take a reading at 14 also. If this reading remains constant and the other three drop, the trouble is probably between the antenna and the plate of the r.f. tube (2). The next example will discuss this.

Of course, sometimes only a single power supply circuit is defective—for example, a separate screen grid supply or the plate supply to an r.f. or i.f. stage. This may have so little effect on the main power supply that the reading at 14 won't be appreciably lowered. Such defects will be run down, however, as you check the signal levels in the various stages.

**Example 5.** If the signal tracer channels at all points except 14 show a drop, thus indicating an input circuit defect, you should first move the probe at point 2 to point 1 (the grid of the 12SK7 r.f. tube). If the signal level does not change when the set snaps back, the trouble is in the r.f. tube or its voltage supply circuits. Try a new tube. If the trouble continues, replace  $C_6$ ,  $C_7$ ,  $R_3$  and  $R_2$ , one at a time. In sets which have the plate circuit decoupled by an R-C filter in the B supply, the filter may be defective. Check this by connecting the d.c. meter across the decoupling condenser; if a radical change in voltage occurs when the fade or cut-off takes place, the by-pass condenser is leaky or shorted or the decoupling resistor is open.

If the signal level at the input of the r.f. tube rises when the receiver snaps back, the defect may be in the

r.f. tuning condenser, in its trimmer  $C_5$ , in  $C_3$ , or in the loop. If an outside antenna is used while the receiver is under test, then  $C_2$ ,  $L_1$  and  $C_1$  are possible suspects.

**Other Methods.** You can see from these examples that a signal tracer can be quite valuable in isolating the cause of intermittent reception. Exactly how valuable the instrument is depends on how complete it is. A tracer with all the channels mentioned in our examples is the most useful, but less complete instruments can often be very helpful.

For instance, types which have only a single r.f.-i.f. channel can be used to trace any defect between the antenna and second detector, by moving the probe along until you find the point where the signal level decreases. The types with audio channels can be used similarly to check the audio amplifier.

If you do not have a d.c. type vacuum tube voltmeter, you can use any d.c. voltmeter to measure supply voltages and any high-sensitivity meter to get a rough check of the a.v.c. voltage. Similarly, you can use a high-sensitivity d.c. voltmeter across resistor  $R_5$  to determine if the oscillator is functioning.

Thus, using a signal tracer is not the *only* way to localize the trouble. It is, however, one of the best ways.

## MAKING THE SET FADE

Sets are often exasperatingly slow to cut off when you have them on the bench. To save time and to avoid tying up your test equipment any longer than necessary, you're wise to speed up the process as much as you can. Here are some practical ways to do so.

► You can make a thermal intermittent appear much more quickly by covering the chassis with a heavy

piece of canvas or with a large cardboard box to trap the natural chassis heat.

► Increasing the line voltage may make the intermittent occur, or may permanently break down the defective part (which you can then quickly locate by routine tests). The only other parts which may break down are those that are near the ends of their useful lives and would soon have to be replaced anyway.

You can vary the line voltage most readily by inserting a tapped or variable transformer between the line and the set. The schematic of a simple device you can make yourself with a toy train transformer is shown in Fig. 14. This arrangement will vary the applied voltage from about 85 volts to 130 volts. (Never apply more than 130 volts to an a.c. receiver.) The device will give you voltages higher than the line voltage with the double-pole, double-throw (d.p.d.t.) switch  $SW_1$  in one position, and voltages lower than the line voltage with the switch in its other position.

Lower-than-normal supply voltages are useful if you suspect the oscillator is cutting out. In three-way receivers using low-voltage filament type tubes, even a slight decrease in oscillator filament voltage will stop the oscillator. So, if you encounter a three-way set which fades on power line operation but not on battery operation, try reducing the line voltage to see if you can thus reproduce the observed intermittency.

Sometimes it may be necessary to operate the set for several hours with higher-than-normal voltage. This will not cause you any difficulty, since most toy transformers can supply as much as 5 amperes continuously without overheating.

► Many sets fade in and out when a light switch is thrown. Make sure

this is not caused by a poor ground system at the customer's home. If it is not, duplicate the on and off clicks at the shop by inserting a flasher button (the type used with Christmas tree lamps will do) in series with a 100-watt lamp across power line near the receiver plug. The thermostatic flasher will regularly cut the lamp off and on so surges will travel to the radio. When the set stops, cut off the flasher and start trouble-shooting on the chassis. If the set snaps back on, use the flasher again until the cut-off recurs.

**Testing Parts.** While substitution is sometimes the only way to learn whether or not a suspected part is

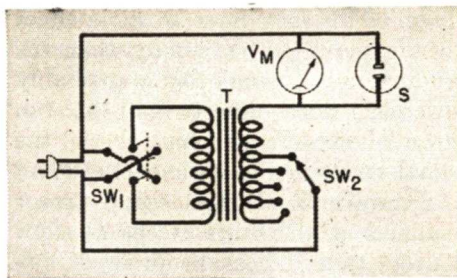

FIG. 14. How to connect a toy transformer to step up or step down the line voltage.

actually defective, often a very careful examination combined with mechanical wiggling will give definite proof.

An ohmmeter will sometimes show up an internal defect in coil windings by giving a varying meter reading.

You can check for tuning condenser short circuits by unsoldering the coil leads and connecting an ohmmeter between the stator and rotor. If the ohmmeter gives a reading or flicker when you rotate the condenser gang, a short exists. To remove it, you must clean between the plates, burn out metal peelings in the manner described in the noise section of this lesson, or bend the plates.

Trimmers can be disassembled and examined under a magnifying glass. This will often let you find cracked mica dielectrics.

## OTHER INTERMITTENT COMPLAINTS

Intermittent fading and cutting off are not the only intermittent troubles you will encounter as a serviceman. On occasion you will deal with receivers which intermittently squeal, hum, distort, and become noisy.

These troubles are easier to conquer than the intermittent fade or cut-off. A hundred and one things might cause a set to cut off or fade, while the other symptoms can be caused by only a limited number of defects. You can usually check these parts readily and isolate the defect in short order.

► For example, suppose a set exhibits intermittent distortion. Leaky coupling condensers are the first logical suspects. You can test for this (as explained elsewhere) while the distortion is present, or simply try new condensers. Gassy tubes are the next possibility—again, you can test or substitute. There are very few other distortion-producing defects which can appear intermittently. However, if you do happen to strike the unusual case, a signal tracer will quickly point out the defect.

► Intermittent oscillation may be caused by a faulty by-pass condenser or by corroded shield contacts.

► In the case of intermittent hum, check the electrolytic filter condensers and the plate and screen by-pass condensers for opens. If an electrolytic in a cardboard case is secured to the chassis by a metal strap, suspect leakage between the strap and condenser through the cardboard cover. (You can eliminate this by removing the strap and allowing the condenser to be self-supporting in the chassis.)

Always be suspicious of tubes—intermittent heater-to-cathode leakage, which produces hum, is fairly common.

► Intermittent noise is more difficult as it can be caused by many of the part defects listed earlier in this lesson. In fact, constant noise will seldom be encountered, but it usually lasts long enough to allow the source to be located. Tubes and transformers are most likely to be intermittently noisy. Jarring these parts will usually show up the offender.

## A CHECK LIST

Always remember that an intermittent, like any other radio defect, has a plain, everyday cause which you can find if you're patient and careful enough. When you get a tough job that seems to defy every rule of servicing, run over the following list of causes of intermittents to see if you have forgotten something. You'll be surprised how often this will solve your problem.

### Antenna Circuit:

Corroded joint between lead-in and antenna; poor contact at rivets in lead-in strip; poor contact between wire and clip on lead-in strip; faulty contact between ground clamp and ground; antenna lead shorted to chassis; antenna rubbing against conductive or semi-conductive material.

### Oscillator Circuit:

Tube checks okay but does not oscillate; tuning condenser plates peeling and partially shorted; electrical breakdown in padding condenser mica.

### Power Supply:

Faulty contacts within filter condenser; improper contact between slider and voltage divider; broken

turn on divider, not apparent before a complete separation occurs; leakage across insulation between two divider taps; high-resistance contact in ON-OFF switch, leakage between wires.

**Speaker:**

Poor connection at voice coil leads; scratch across voice coil winding (intermittently shorting the coil or turns on the coil); voice coil which opens when cone moves too far.

**Power Line:**

Arcing contact at fuse block or at wall plug; leak between transformer winding and core; fused outlet contacts (contacts rough and pitted because of arcing).

**Volume Control:**

Loose terminal wire at inside lug; dirt and wear under slider arm; loose wire in resistance element; increase in ohmic value.

**Tubes:**

Faulty weld at element support (affected by heat); interelement short; cold joint between element lead wire and prong; twisted glass envelope; shorted leads; emission coating drops

between elements after flaking off; poor socket contact to prong; heater-to-cathode leakage; gas in tube.

**By-Pass Condenser:**

Open; shorted; leak between sections.

**Resistors:**

Cracked carbon rod; loose terminal connection; contact with other set parts; in wire-wound type, partial shorts between turns; overheating from overload.

**Tuning Condensers:**

Rubbing or dirty plates; poor connection between rotor and chassis (faulty wiping contacts); poor connection to stator plates; cracked mica in trimmers.

**A.F. Transformers:**

Inter-winding leak; imperfect insulation between winding and core.

**R.F. Transformers:**

Cold soldered joint at lug; shorts between windings because of crossing of wire leads or deterioration of enamel insulation.

## Lesson Questions

Be sure to number your Answer Sheet 43RH-1.

Place your Student Number on every Answer Sheet.

Send in your set of answers for this lesson immediately after you finish them, as instructed in the Study Schedule. This will give you the greatest possible benefit from our speedy personal grading service.

1. Where is the source of noise, if the noise is still heard after removing the antenna and ground connections and installing a line noise filter?
2. Suppose the receiver is noisy when jarred, but the noise disappears when the volume control is turned to the minimum volume position. In which section of the set is the noise source located?
3. The noise stops when a tube is removed, but reappears while the plate-chassis voltage is being measured with a voltmeter. In which circuit of this stage is the noise source located?
4. Name three mechanical defects you would look for if noise is heard only as the station selector (tuning) knob is turned.
5. When following the stage-blocking method of pulling out tubes one at a time, you find the noise is decreased but not completely blocked. In which section of the receiver is the noise source located?
6. If the complaint is intermittent hum, which of the following intermittent defects would you suspect: 1, open coupling condenser; 2, open screen grid bleeder resistor; 3, open output filter condenser; 4, open plate supply resistor?
7. What is the brute force technique (used on intermittent receivers)?
8. Suppose an audio signal tracer shows an intermittent change in volume when at the junction of  $C_{20}$  and  $R_{10}$  in Fig. 13, but a steady signal exists at point 12. Which two parts are the most logical suspects?
9. Suppose the loudspeaker volume varies, but a signal tracer connected to point 9 of Fig. 13 shows a normal steady signal. Where is the trouble?
10. Where in Fig. 13 would you connect a high ohms-per-volt meter to determine whether the intermittent trouble is in the a.f. section or in the r.f. section?

---

THE N. R. I. COURSE PREPARES YOU TO BECOME A  
**RADIOTRICIAN & TELETRICIAN**  
(REGISTERED U.S. PATENT OFFICE) (REGISTERED U.S. PATENT OFFICE)



## HOW AND WHY

There is an exceptionally fine quotation I want to pass on to you. I do not recall the name of the author, but the truth in the quotation makes it unforgettable. Here it is:

*"The man who knows HOW will always have a job—the man who knows WHY will be his boss."*

Your N.R.I. training fits this thought perfectly. You are being taught HOW to service radio receivers, so you can be sure of plenty of work in this, your chosen field. Also, your fundamental training gives you the background of WHY radios function as they do, WHY they break down, and WHY the particular servicing methods we recommend lead directly to the source of trouble.

We not only want you to be a successful serviceman—we want you to have an assured future, with every opportunity to advance to the top. You will need only the touchstone of a little practical experience to weld your "HOW and WHY" training into a single, compact unit of knowledge which can lead you wherever you wish to go.

*J. E. Smith*