

# **SIMPLE RADIO CIRCUITS AND METERS**

**3FR-2**



**NATIONAL RADIO INSTITUTE**

**WASHINGTON, D. C.**

**ESTABLISHED 1914**



## STUDY SCHEDULE NO. 3

By dividing your study into the steps given below, you can master this part of your N.R.I. Course quickly and thoroughly. Check off each step when you finish it.

**How to Study Each Step.** Unless otherwise instructed, first read the pages specified for the step at your usual reading speed. Next, reread them slowly enough so you understand every paragraph. Go over the material as often and as slowly as you find helpful, endeavoring always to *understand* as well as remember. Finish up with one quick reading to tie the ideas together in your mind, then write down roughly on scrap paper your answers to the questions specified for that step. After finishing the lesson, copy all your answers neatly and in order on an Answer Sheet.

- 1. Meters Tell What Circuits Are Doing.....Pages 1-2  
Read this introductory section slowly just once. You will find out why meters are studied along with simple circuits. A few of the interesting ways in which you will use meters in your radio work are described.
- 2. What Radio Men Measure.....Pages 3-5  
In this section, important facts about voltages, currents and resistances which you measure in radio work are given in a straightforward, easy-to-remember manner. Answer Lesson Questions 1, 2 and 3.
- 3. How Voltage and Resistance Affect Current in Simple Circuits..Pages 6-10  
Here is information which you will use in practically every radio job, so give it all you've got! Answer Lesson Questions 4 and 5.
- 4. Load Connections for Radio Circuits.....Pages 10-13  
You'll learn how loads can be connected either in series or in parallel to a voltage source, and you'll find out how a voltage-dropping resistor uses up some of the source voltage. Answer Lesson Questions 6, 7 and 8.
- 5. What Makes Meters Work.....Pages 14-21  
Meters will mean a lot to you after you read this clear and interesting explanation of how the basic meter works, and how it is used with a few simple additional parts to give us all of the meters ordinarily used by radio men. Answer Lesson Question 9.
- 6. Voltage Sources for Radio Circuits.....Pages 21-28  
An interesting section dealing with storage batteries, dry cells, B batteries, and other voltage sources used in radio circuits. Answer Lesson Question 10, then read "Looking Ahead."
- 7. Mail Your Answers for Lesson 3FR-2 to N.R.I. for Grading.
- 8. Start Studying the Next Lesson.

## SIMPLE RADIO CIRCUITS AND METERS

### Meters Tell What Circuits Are Doing

RADIO receivers, transmitters, public address systems and photoelectric controls are all alike in the sense that each one is made up of various combinations of *simple circuits*. Once you are familiar with the few simple circuits which are used over and over again in radio apparatus, you will have a good practical start toward understanding the complete circuits of receivers and other equipment.

This third lesson of the N.R.I. Course is a particularly important part of your training, because it gives the practical facts you want to know about these simple circuits in order to become a capable and well-trained radio man.

In addition, this third lesson explains in detail how different kinds of meters are used to find out what is going on in simple circuits. Since meters are the radio man's most valuable tools, and since this is definitely a practical training course in radio, it is logical that you study meters along with circuits.

As you study this lesson, you are going to be pleasantly surprised at how much the previous two lessons are already helping you. You have really acquired a wealth of information about radio, and you will already be using this knowledge.

To illustrate the importance of knowing how to use meters, we will now consider a few of the ways in which meters are used by radio servicemen and radio operators on actual jobs.

**How a Serviceman Uses Meters.** Let's look into the future for a few minutes now, and imagine that you are the owner of a prosperous radio servicing business on the main street of your home town. A customer brings in his table model radio receiver, say-



Serviceman using a d.c. voltmeter to check the plate voltages of tubes in a defective receiver. A few simple measurements with meters are often enough to locate a defective part.

ing: "It went completely dead last night, right in the middle of my favorite program. This never happened before!"

Taking the receiver to the test bench, you transfer the tubes one by one from the receiver to your tube tester, an instrument having a meter as its most important part. For every tube, the meter pointer swings to the green area marked *GOOD TUBE*.



The tubes are okay, so now you begin using your knowledge of radio fundamentals and servicing techniques. With the receiver turned on, you momentarily remove each tube in turn or touch its top cap. The resulting clicks or thumps in the loudspeaker for some but not all tubes tell you which stage of the receiver is at fault.

Now you reach for another instrument (a *voltmeter*) and measure the voltage at each electrode of the tube in this stage.

"Ah ha! No plate voltage. Something wrong here!", you exclaim in triumph. You have traced the trouble to one simple circuit, and a few quick measurements reveal the breakdown part which made the set go dead.

Your meters thus locate for you in a few minutes a part which is defective even though it looks perfectly good. After the meters have done their work, it takes just a few minutes longer to remove the defective part, put in a brand-new replacement part, then give the receiver a final complete check-up before handing it back to your customer and collecting your money.

Watching you at work in that imaginary radio shop of the future is a great deal like watching a doctor meet his daily assortment of patients. Just as the doctor uses thermometers, X-ray machines, stethoscopes and other instruments to supplement his medical knowledge in analyzing and treating human ailments, so do you use meters of various types to supplement your radio circuit knowledge in locating the causes of receiver ailments.

**How a Radio Operator Uses Meters.** The scene changes. Imagine that you are a radio operator temporarily assigned to the evening shift at a powerful broadcasting station.

From your control desk in the center of the transmitter room, you can see dozens of meters, arranged in rows on the metal panels of the transmitter. Each meter has its own particular story to tell you about one of the simple circuits in that transmitter.

Let's say it is 10 o'clock, with three more hours to keep the station on the air, when the pointer of one meter begins slowly creeping downward. The meter is telling you that one of the tubes is starting to fail.

You get a new tube and place it on your desk, ready for speedy replacement if necessary. But you don't put in the new tube now, because that would mean shutting off the transmitter. From experience, you know the tube will probably last quite a few hours yet anyway.

Fortunately, the tube does last. The announcer signs off for the night, you open up the master switches and disconnect all power from the transmitter, then you pull out the failing tube and put in the new tube.

Clearly, meters help you to keep a transmitter on the air. Without meters, you wouldn't know anything was wrong until a tube actually failed, and then would lose many precious minutes in finding out which tube had failed.

In addition to helping you locate trouble, the meters in a transmitter tell you when each circuit is correctly adjusted so the transmitter and the transmitting antenna will be operating at maximum efficiency. Even the monitor operator in the control room relies on a meter to aid in adjusting the volume control.



## What Radio Men Measure

There are only three *values* which radio men ordinarily need to measure in a radio circuit: *voltage*, *current* and *resistance*.

You already have a general idea of what *d.c.* and *a.c. voltages* are like, and are also somewhat familiar with both *alternating current* and *direct current*, so we need only review these subjects briefly before taking up the new subject of electrical *resistance*.

A great many technicians think of voltages, currents and resistances as *things which can be measured with meters*. If you mention 45 volts to them, they immediately think of a meter with its pointer at 45 volts. Practical slants like this are emphasized throughout your N.R.I. Course, along with essential technical information.

### Voltage

The electrical "pressure" which is capable of setting electrons into motion in a circuit is called *voltage*. Any device which produces a voltage is a *voltage source*. Storage batteries, dry cells, and generators are all voltage sources.

The stronger the voltage, the greater the effect it has on electrons. The term *volt* is used by radio and electrical men as a convenient unit for specifying the *strength* of a voltage source. For example, a 6-volt storage battery is stronger or *higher in voltage* than a 2-volt storage battery.

Voltages are measured with meters called *voltmeters*. Though scientists have elaborate ways of specifying how much a volt is, a radio man is satisfied to rely upon his voltmeter to tell how many volts a particular voltage source has.

**D.C. Voltage.** A voltage which

always moves electrons in the same direction is a *d.c. voltage*. It always has the same polarity. (One terminal is always + and the other always -).

The *d.c. voltage* sources most often used in radio are dry batteries, storage batteries, *d.c. generators*, and power packs. (A power pack converts *a.c. voltage* to *d.c. voltage*.)

**A.C. Voltage.** That type of voltage which reverses its polarity regularly, sending electrons through the circuit alternately in one direction and then in the opposite direction, is known as an *a.c. voltage*. The electrons do useful work, however, even though they just move back and forth many times each second without getting anywhere.

*A.C. generators*, ranging in size from the huge units in power plants down to small units driven by gas engines, are *a.c. voltage* sources. In addition, every radio signal source produces an *a.c. voltage*. Microphones, oscillator circuits, transformers and receiving antennas are thus all *a.c. voltage* sources.

**How A.C. and D.C. Voltages Act Together.** Here is a fact which is sometimes hard to believe: Both *a.c.* and *d.c. voltages* can exist in the same circuit.

When there are *a.c. voltages* in the same circuit with a *d.c. voltage*, *each voltage will act independently* just as if the others didn't exist. By using the proper meters, you can even measure these voltages independently.

Every amplifier stage is an example, for you have in the grid circuit a *d.c. voltage* (the C bias voltage), and an *a.c. signal voltage* provided by the signal source.

**Pulsating D.C. Voltage.** When a *d.c. voltage* is varying regularly in



value above and below a fixed value, without reversing its polarity, we have a *pulsating d.c. voltage*. It is simply a d.c. voltage combined with a smaller a.c. voltage, and these two voltages can be considered independently just as if they were separate voltages.

The most familiar example of a pulsating d.c. voltage is that produced by the rectifier tube in the power pack of a radio receiver. Remember, a pulsating d.c. voltage always has the same polarity, but changes in strength or value continuously.

**Other Names for Voltage.** You will sometimes find the terms *potential* and *electromotive force* (abbreviated *e.m.f.*) used in place of voltage. Potential means essentially the same as voltage, while e.m.f. is used only for voltages produced by true basic voltage sources like batteries or generators.

### Current

The electron movement produced by a voltage is called a *current*. More generally speaking, any flow of electricity is a current.

The more electrons we have moving past a given point per second, the *stronger* is the current. The *ampere* (pronounced *AM-peer*) is the basic unit used for specifying the *strength* of a current. For instance, an automobile storage battery supplies about 5 amperes of current to an auto radio receiver, about 200 amperes to the starter, and about 7 amperes to each headlight bulb.

In radio work, we deal so much with currents smaller than one ampere that we frequently use a smaller unit called the *milliamper* to specify the strength of a current. A milliamper is *one-thousandth of one ampere*, so 1,000 milliamperes is equal to one ampere.

Current values are measured with meters called *ammeters* or *milliam-*

*meters*. Ammeters indicate the current value in *amperes*. Milliammeters indicate the current value in *milliamperes*.

Since current-measuring meters give current values in amperes or thousandths of an ampere, there is no need for you to know how many electrons per second are involved in a current flow of 1 ampere. The actual figure is unimaginably large, and is presented here only as an oddity of science: *It takes 6.3 million million million electrons moving past a given point in one second to give a current of 1 ampere.*

**Direct Current.** A current which consists of electrons flowing always in the same direction is a *direct current*. It is produced by a d.c. voltage.

With direct current, the direction in which electrons are moving is of importance only when we need to figure out the correct polarity for connections to batteries, meters or radio parts. When direction is important, we speak of *electron flow* and specify a direction; when direction does not matter, we just speak of *current*.

Both batteries and radio tubes can serve as "signposts" in circuits, just as is shown in Fig. 1. These parts tell us which way electrons are moving. Thus, electrons always move away from the *negative* battery terminal,

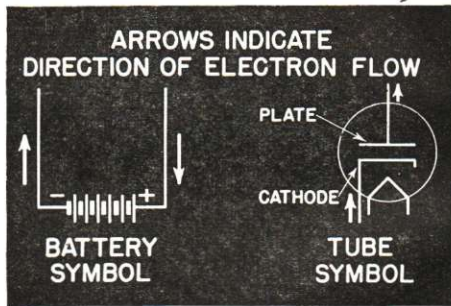

FIG. 1. Batteries and tubes are the signposts of radio circuits, for they tell you the directions of electron flow in d.c. circuits.

and move through the circuit towards the *positive* terminal of the battery.

In a tube circuit, the electron flow is always in such a direction that the electrons flow from the cathode to the plate in the tube.

**Alternating Current.** A current which consists of electrons which regularly reverse their direction of motion is an *alternating current*.

**Pulsating Direct Current.** A current which changes regularly in strength but still consists of electrons flowing always in the same direction is a *pulsating direct current*. It is produced by a pulsating d.c. voltage, which is really a combination of a d.c. voltage and an a.c. voltage.

### Resistance

The opposition which a wire, radio part or circuit offers to the flow of electrons is called *resistance*.

Everything has resistance, but metals like copper and aluminum have very low resistance. These metals offer little opposition to electron flow, and are therefore considered to be good paths for electrons and good conductors of electricity. Copper is the metal most frequently used when resistance should be very low, such as in the connecting wires of radio circuits. The resistance of a copper connecting wire is so low that it is usually neglected by radio men, and the wire is assumed to have *zero resistance*.

Materials like carbon and nichrome have quite a high resistance, and are used in radio circuits when it is necessary to reduce the strength of a current to a desired value.

**The Ohm.** The unit used for expressing the *amount* of resistance is the *ohm* (pronounced like "ome" in "home," and named after the scientist George Simon Ohm). Radio men use

meters called *ohmmeters* to tell how many *ohms* of resistance a part has.

**Resistors.** When we want to reduce the amount of direct current flowing through a circuit, we connect into the circuit a radio part called a *resistor*. (*Resistance* is the actual opposition to electron flow, while a *resistor* is a part which has *resistance* or opposition to electron flow.)

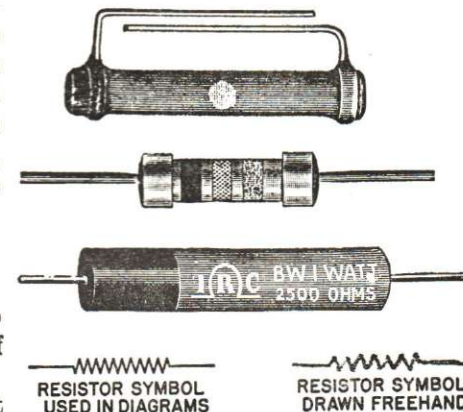

FIG. 2. Here are some illustrations of typical radio resistors. The symbol used to represent resistors is shown in two forms—as it appears in printed diagrams, and as it would be roughly sketched by a radio man.

Two types of resistors are widely used in radio apparatus. *Carbon-type resistors* are made from a mixture of powdered carbon and a special cement. *Wire-wound resistors* are usually made from nichrome wire.

Examples of resistors you will work with are shown in Fig. 2, along with the symbol used on diagrams to represent a resistor. Practice drawing this zig-zag symbol which says to radio men "Here's a resistor."

The fifth lesson in your Course is devoted entirely to resistors, so we won't say much more about them now. For this lesson, all you need to remember is that a resistor is a radio part which *limits current*.



# How Voltage and Resistance Affect Current in Simple Circuits

Every complete circuit has at least two parts, a *voltage source* and a *load*. The source and load can be connected together either by wires or radio parts.

The two things which affect the amount of *current* flowing in a complete circuit are the *voltage* of the source and the *resistance* of the load and other parts in the circuit. With the aid of meters, we can find out exactly what happens to the current when changes are made in voltage or resistance.

Continuing with our practice of talking in the radio man's language, we shall use throughout this lesson two terms which describe the two basic ways of connecting radio parts together in circuits. Here are the meanings of these terms:

**In Series.** When radio parts are connected together end to end, so that electrons flow through one part after

another, we say that they are *in series*.

**In Parallel.** When radio parts are connected all to the same two terminals, so the electron flow divides among the parts, we say they are *in parallel*.

## How Voltage Affects Current

Suppose you have a simple circuit consisting of a  $1\frac{1}{2}$ -volt dry cell as voltage source and a 500-ohm resistor as load. You want to find out what happens to the *current* in the circuit when you increase the *voltage* by adding more dry cells *in series*.

Let us assume that for the current measurement you choose a milliammeter which reads from 0 to 10 milliamperes (abbreviated 0-10 ma.), and for the voltage measurement you choose a voltmeter which reads from 0 to 5 volts.

**One Cell.** You connect the volt-

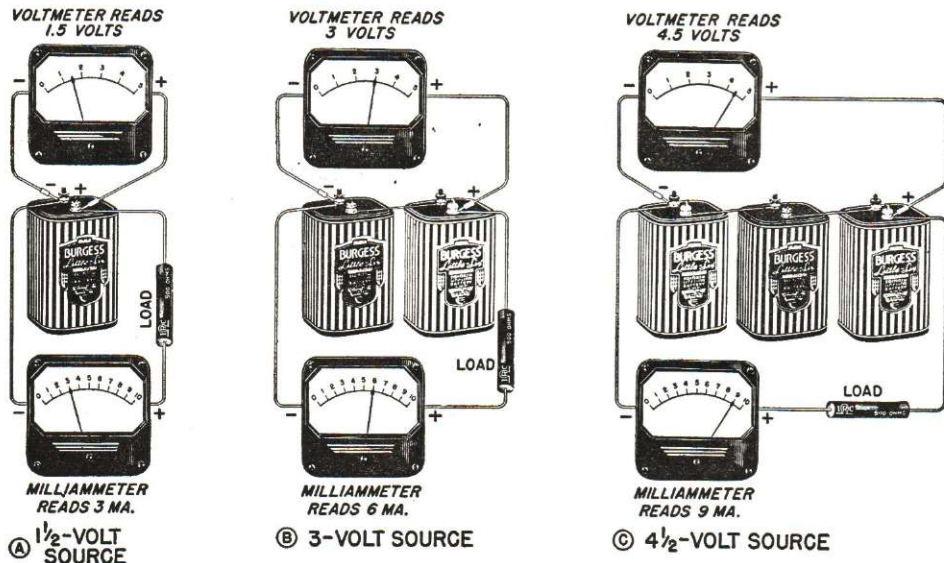

FIG. 3. These simple circuits with meters show you how voltage affects the current in a circuit.

SOURCE VOLTAGE	CURRENT
$1\frac{1}{2}$ VOLTS	3 MILLIAMPERES
3 VOLTS	6 MILLIAMPERES
$4\frac{1}{2}$ VOLTS	9 MILLIAMPERES

FIG. 4A. This table gives the results of the measurements pictured in Fig. 3.

meter across the two terminals of the cell which serves as the voltage source, and connect the milliammeter *in series* with the load resistor, as shown in Fig. 3A. The voltmeter reads  $1\frac{1}{2}$  volts and the milliammeter reads 3 milliamperes (usually abbreviated as 3 ma.), so you record these values on a piece of paper, somewhat as shown in Fig. 4A.

**Two Cells.** The next question is—what will happen to the current if you double the voltage? To find out, you add another cell in series to your circuit, as shown in Fig. 3B, and read the meters again. The voltmeter reads 3 volts (twice the first voltage) and the milliammeter reads 6 ma. (twice the first current), so you record this set of values also in Fig. 4A.

**Three Cells.** Suppose you are still in an experimental mood, and add another dry cell to your circuit, as in Fig. 3C. Now the voltmeter reads  $4\frac{1}{2}$  volts and the milliammeter reads 9 ma., so these values are recorded in Fig. 4A.

**Conclusion.** Now, what do these results mean? Well, by carefully studying and comparing the values in Fig. 4A, you could figure out for yourself the conclusion that *current increases when you increase the voltage*.

**Graph Diagrams.** It is not always easy to make correct conclusions just by studying a list of measured values, however. This is why radio men so often use a special diagram called a *graph* (pronounced *GRAFF*), which gives an easily-understood picture of the story hidden in a series of measured values.

**Bar Graphs.** For example, we could take the values obtained in our little experiment and use them as the basis for a bar graph like that shown in Fig. 4B. One glance at this graph is almost enough to tell you that the current goes up when the voltage is increased.

**Radio Graphs.** The bar graph has

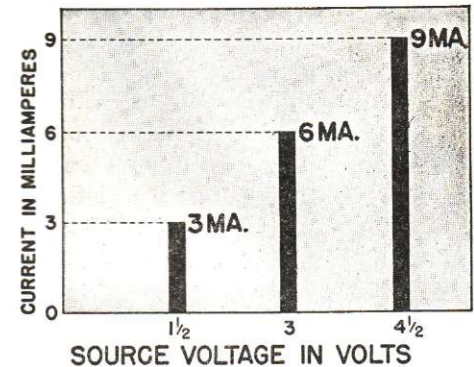

FIG. 4B. This graph presents the results of the Fig. 3 measurements in a manner more quickly understood than the table in Fig. 4A. You will often find bar graphs like this in newspapers, where they are used to show such things as the number of homes built each month of the year.

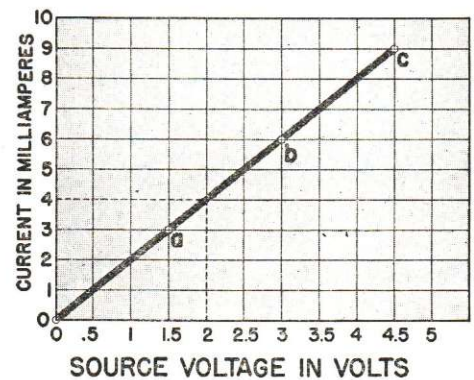

FIG. 4C. Here's the way a radio man would present the results of his measurements for the circuits of Fig. 3. This type of graph is easily drawn, and has the added advantage that it tells what the current will be for other values of voltage besides those measured.



one drawback for the radio man—it does not tell anything about values in between those actually measured. The radio man almost always uses a graph like that shown in Fig. 4C, because he can determine from this graph what the current will be for *any* value of voltage between 0 and 4.5 volts. Here is how this graph would be made up from the values in Fig. 4A.

**Making a Graph.** Starting with the first set of values in Fig. 4A, you locate 1.5 volts on the voltage scale at the bottom, and note the vertical (up and down) line which goes through this value. Next, you locate 3 on the current scale at the left and note the horizontal line which goes straight across the graph from this value. Move to the right along this line until you come to the vertical line going down to 1.5 volts, and at the crossing draw a dot or small circle, just as at *a* in Fig. 4C. This first point on your graph corresponds to the top of the shortest bar in Fig. 4B.

In the same way, you go up from 3 volts and to the right from 6 ma. until you reach point *b* on your graph and place a circle there. Finally, place a circle at *c* for 4.5 volts and 9 ma.

A bit of reasoning tells you that if the voltage is zero, no electrons will be flowing through the circuit, and the current will consequently be zero, so you place a small circle at *0* also.

Placing a ruler on your graph, you see that all four circles (*0*, *a*, *b* and *c*) are on a straight line. Therefore, as the final step in making this radio graph, you connect the four small circles together with a straight line.

**Radio Curves.** Whenever radio men connect together a series of points on a graph like this, they call the resulting line a *curve*. In fact, most of the graphs encountered in radio are

actually curves because the points are not on a straight line.

**What a Graph Tells.** A radio graph like that in Fig. 4C gives even more information than the original set of values. For instance, if you wanted to know what the current would be for a voltage of 2 volts in the circuit of Fig. 3, you would simply trace up from 2 volts till you hit the curve, then trace left to the current scale and read 4 ma. as the current. Try this yourself for 2.5 volts. If you get 5 ma. as the current for 2.5 volts, you have the right idea.

**Remember This.** The one important idea for you to get from this entire experiment is that *when you increase the voltage, the current increases too*. This basic rule works backwards just as well—when you *decrease* the voltage, the current goes down.

#### How Resistance Affects Current

**Another Experiment.** Now, let us take the very same circuit shown in Fig. 3C, and see what happens to the current in the circuit when we increase the resistance.

**One Meter is Enough.** The only meter we need for this next experiment is a milliammeter, because we will leave the voltage source value fixed at  $4\frac{1}{2}$  volts. Our new circuit arrangement is shown in Fig. 5A.

The milliammeter can be anywhere in the circuit, because *the same amount of current flows through every part of a complete series circuit like this*.

**One Resistor.** We start with one 500-ohm resistor, and get the same 9-ma. current as for the circuit of Fig. 3C.

**Two Resistors.** How can we increase the resistance in this circuit? Well, the simplest way is by adding more 500-ohm resistors. If we con-

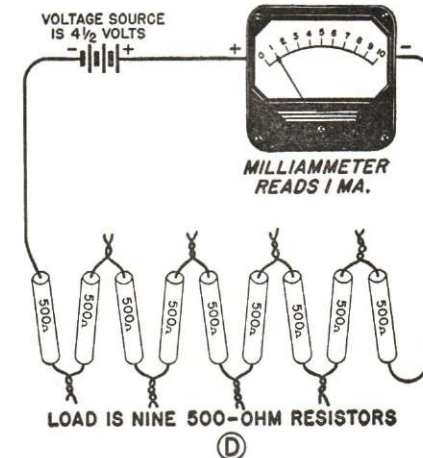
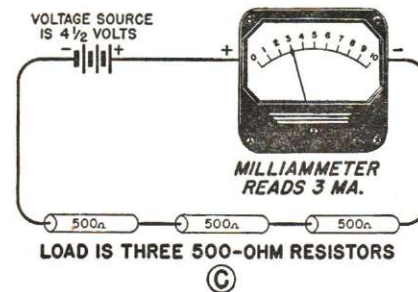
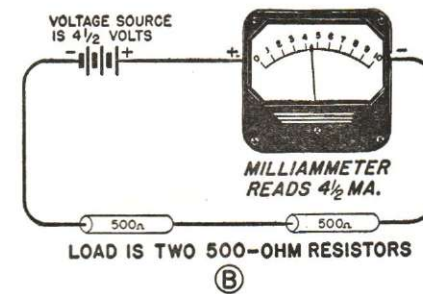
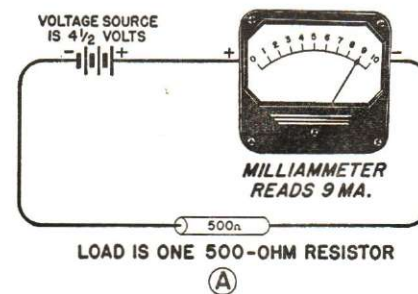

FIG. 5. These experimental circuits illustrate the basic fact that current GOES DOWN when you INCREASE the resistance in a circuit by adding resistors in series. If you start at circuit D and work back through C and B to A, these circuits will also illustrate the reverse condition, that current WILL INCREASE when you REDUCE the resistance in a complete circuit.

nect them *in series*, their resistance values will *add*.

Thus, two resistors in series as in Fig. 5B give us a total circuit resistance of  $500 + 500$ , or 1000 ohms. We now have twice as much resistance in the circuit as before, and the milliammeter now reads  $4\frac{1}{2}$  ma. This, incidentally, is exactly one-half of the reading we obtained in Fig. 5A.

**Three Resistors.** We continue increasing the resistance in the circuit, and make another measurement with three 500-ohm resistors in series to give a total of 1500 ohms. The milliammeter reads 3 ma. now, which is less than for either of the two previous measurements.

**Nine Resistors.** Finally, we take nine 500-ohm resistors in all, and con-

nect them in series as shown in Fig. 5D. Adding the values of these resistors together gives us now a total circuit resistance of 4500 ohms. With this resistance, the milliammeter reads 1 ma., which is still lower than before.

**The Reverse Situation.** If we start with high resistance in our circuit, as in Fig. 5D, we will have an initial current of 1 ma. Now if we *decrease* the amount of resistance in our complete circuit by removing six resistors, the current will *increase* to 3 ma., as in Fig. 5C. Decreasing the resistance still more, as in Figs. 5B and 5A, makes the current increase more yet.

**Conclusion.** The important facts to remember are that circuit current *decreases* when we *increase* the circuit



resistance, and circuit current *increases* when we *decrease* the circuit resistance.

### A. C. Measurements

Measurements in a.c. circuits are made in essentially the same way as d.c. measurements. Special a.c. meters must be used for a.c. measurements, and polarity of connections does not matter, but a.c. meters measure voltage and current just like d.c. meters. You're interested in actual values—

volts, amperes or milliamperes—and that's what a.c. meters show.

The amount of current flowing in an a.c. circuit depends upon the source *voltage* and the circuit *resistance*, just as it did for d.c. circuits.



Just two terminals—that's all you'll find at the back of practically any radio meter. On d.c. meters, the positive terminal will usually be marked +. The other terminal, not marked, is negative (-).

## Load Connections for Radio Circuits

**Radio Loads.** In radio, loads are grouped together quite frequently. For example, a radio receiver may have from 4 to 10 or even more tubes, with each tube filament acting as a load and hence requiring a voltage. Instead of using a separate filament voltage source for each tube, we can connect the filaments together either in series or in parallel and use one common

voltage source (or two at the most) for all of the filaments.

In a series connection of loads, the same current flows through all of the loads, one after another. In a parallel connection of loads, a different current flows through each load. With this distinction between series and parallel connections in mind, let us consider examples of these connections in radio receivers.

**Loads in Series.** When loads are connected together *in series*, the same current flows through all the loads. The total available voltage is divided among the loads, however, in proportion to the resistance of each load. The *sum* of the individual load voltages is then equal to the total voltage available for all the loads. Let us see how this applies to such well-known loads as tube filaments.

**Filaments in Series.** The filaments of radio tubes can be connected together *in series* if all of the filaments have the *same current rating* and the available voltage is *high enough* to take care of *all the required filament voltages added together*. The filament

circuit arrangement shown in Fig. 6 for a 5-tube universal a.c.-d.c. receiver is a practical example of this. All the tubes have the same filament current ratings, and the power line provides a voltage which is just about equal to the sum of the required filament voltages. (A tube will operate satisfactorily even if the filament voltage is a bit higher or lower than the rated value.)

**Loads in Parallel.** When loads are connected together in parallel, all loads get the same voltage. The current flowing through each of the loads will depend upon the resistance of that load. Again we have tube filaments as examples, so let us consider the conditions under which these familiar loads can be connected in parallel.

**Filaments in Parallel.** The chief requirement for connecting the filaments of radio tubes together *in parallel* is that all of the tubes must have the *same filament voltage rating*. The available source must, of course, provide this voltage value, and in addition must be able to furnish a current

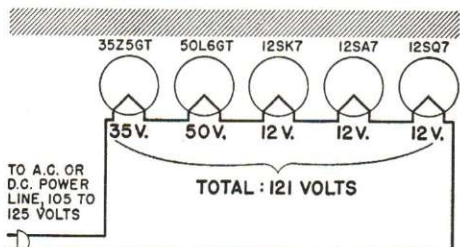

**FILAMENTS IN SERIES (UNIVERSAL A.C.-D.C. SET)**



FIG. 6. Practical example of loads connected in series. This example is taken from an actual receiver, and the type numbers of the tubes used in the receiver are given above the tube symbols. Notice how the first two numerals in the type number of a tube tell its filament voltage. This holds true only for newer tubes, however.



Courtesy Zenith Radio Corp

Before each man on this final inspection line of a huge radio factory are meters which tell whether or not each receiver performs as it should. No matter what radio factory you visit, you will see hundreds of meters in use, telling radio men what is going on in radio circuits.

and all five filaments are connected in parallel to this winding.

### Voltage-Dropping Resistors

**Too Much Voltage.** Very often in radio, we have a voltage source which provides a certain definite voltage value, and we have a load which requires a lower voltage value. In other words, the load requires only a portion of the source voltage, and there are no other loads which can use up the remainder of the voltage.

**Getting Rid of Voltage.** We take care of a surplus-voltage condition in radio work simply by inserting in the circuit a *resistor* which will use the undesired part of the source voltage. This resistor uses up surplus voltage in much the same way that automobile brakes use up part of the forward-

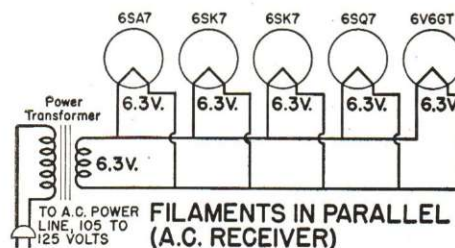
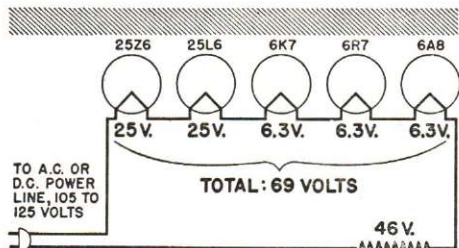

FIG. 7. Practical example of loads connected in parallel. The tube numbers are those of an actual receiver using this connection, so you are already studying real receiver circuits.

equal to the sum of all the rated filament currents.

The arrangement in Fig. 7 is a practical illustration of filaments connected in parallel. The five tubes each require a filament voltage of 6.3 volts. On the power transformer is a secondary winding which provides 6.3 volts,





**VOLTAGE-DROPPING RESISTOR**

**FIG. 8.** Universal a.c.-d.c. receivers usually have a voltage-dropping resistor which uses up that portion of the line voltage not needed by the tube filaments.

**NOTE:** When a radio man encounters a number like 68.9, he calls it 69 because that is sufficiently accurate for practical radio purposes.

acting force of an automobile when we want to slow down.

**Here's an Example.** A practical example would be a universal a.c.-d.c. receiver having a tube line-up like that shown in Fig. 8. Here the line voltage provides somewhere between 105 and 125 volts, but the tube filament voltage requirements only add up to about 69 volts. Assuming for convenience a line voltage of 115 volts, this leaves 46 volts to be

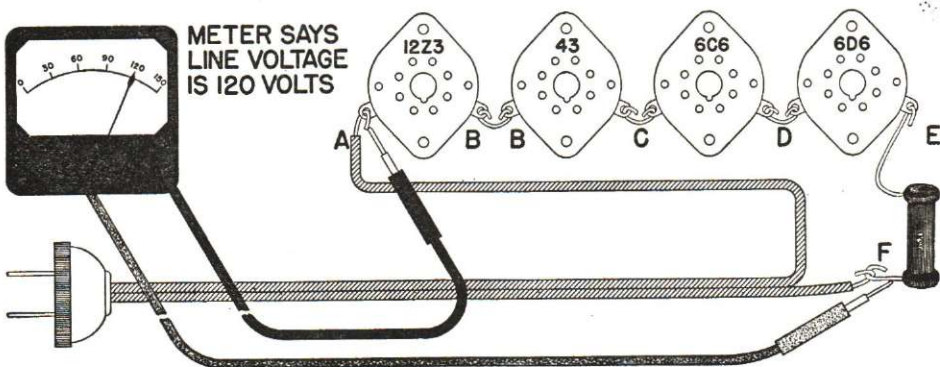

**FIG. 9.** This is how you would measure the power line voltage in a four-tube universal a.c.-d.c. receiver.

used up somewhere in the circuit.

We use up this unwanted 46 volts with a resistor of the correct value, inserted in series with the filaments just as shown in Fig. 8. We can insert this resistor anywhere in the circuit, because the same current flows through all parts of this series circuit.

**What's Its Name?** When a resistor is used in the manner just described, the resistor is called a *voltage-dropping resistor*. In effect, it *drops* the source voltage to the correct value for the load.

**Voltage Rule.** This example illustrates one of the basic rules in radio, that in any one circuit you have to use up *all* of the source voltage. If you don't need it all in the load, you have to insert resistance. Otherwise there'll be too much voltage for the load and something will burn out.

**Voltage Drops.** A voltage drop is simply *some portion of a source voltage*, appearing across a load, resistor or other radio part. Whenever electrons flow through some part, a *voltage drop exists across that part*.

When there are no voltage-dropping resistors in a circuit and there is only one load, the entire source voltage will act on the load. The voltage drop across the load will in this case be ex-

actly the same as the source voltage. An example of this is an ordinary electric lamp bulb. It is connected directly across the 115-volt voltage source, so the voltage drop across the lamp is likewise 115 volts.

**Experimental Proof.** Imagine that you are going to prove for yourself the basic rule *that all of the voltage drops across loads and resistors in a circuit do add up exactly to the source voltage*. You decide to use a universal a.c.-d.c. receiver having the tube arrangement shown in Fig. 9.

First of all, you measure the line voltage by connecting your voltmeter exactly as indicated on the diagram. Suppose you find it to be 120 volts. Now, if the basic rule is to be proved, you must show that the voltage drops across the tube filaments and across the resistor add up to this value.

You measure these individual volt-

MEASURE BETWEEN	VOLTAGE IS	COMMENTS
A and B-----	12 VOLTS	Filament voltage of Type 12Z3 tube
B and C-----	25 VOLTS	Filament voltage of Type 43 tube
C and D-----	6 VOLTS	Filament voltage of Type 6C6 tube
D and E-----	6 VOLTS	Filament voltage of Type 6D6 tube
E and F-----	71 VOLTS	Voltage drop across resistor
<b>TOTAL</b> -----	<b>120 VOLTS</b>	This is equal to the Line Voltage

**FIG. 10.** Here are the results you would obtain if you made measurements on the receiver represented in Fig. 9 to prove that the sum of the voltage drops equals the line voltage.

ages one at a time and jot down their values in the manner shown in Fig. 10, then add up the five measured values. Yes, they do add to 120 volts, so you have proved conclusively that the resistor voltage drops in this series circuit add up to the source voltage.

**Terminals.** Whenever two termi-

nals are connected together by a wire, as are the two terminals marked B in Fig. 9, a connection can be made to either terminal for voltage-measuring purposes, because there is no noticeable voltage drop in the short length of wire which joins these terminals.

**Adding Voltage Drops.** The voltage across two or more parts is simply the sum of the individual voltage drops. Thus, if you measure between points A and C in Fig. 9, you will be measuring the sum of the voltage drops across the filaments of the types 12Z3 and 43 tubes. The data in Fig. 10 indicates that these voltages are 12 volts and 25 volts respectively, and consequently you would measure 37 volts between A and C.

The voltage drops across the resistors in a series circuit must add up to a value exactly equal to the source voltage. This is an important fact for you to remember.

**Polarity of Voltage Drops.** It is occasionally necessary to measure the voltage drop across a load with a voltmeter. Whenever we work with d.c. voltages, the + terminal of the voltmeter must go to the + terminal of the voltage being measured, and hence we may sometimes have to figure out the polarity of the voltage drop across a resistor.

When you know the direction in which electrons are flowing through a resistor or load, the polarity of the voltage drop across the part can be determined by the following simple rule:

*When electrons are flowing through a resistor, the polarity of the resistor terminals WITH RESPECT TO EACH OTHER is such that electrons ENTER the - terminal and LEAVE the + terminal.*



# What Makes Meters Work

**The Basic Meter.** The d.c. milliammeter is the heart of practically all meters used in ordinary radio work. Once you have a general idea of how this basic meter is constructed and how it works, you can very quickly learn how the d.c. milliammeter movement is used in d.c. voltmeters, ohmmeters, a.c. milliammeters, and a.c. voltmeters.

**Looking at a Meter.** From the outside, about all you can see of any meter are the terminals at the back, the glass window at the front through which can be seen the pointer which moves over the meter scale, and possibly also a part of the meter coil. Inside the case is where the differences between meters occur.

**It Works Like This.** The basic idea underlying a d.c. milliammeter can be expressed very simply. Suppose we have a permanent magnet of the modified horseshoe shape shown in Fig. 11A, with a much smaller permanent magnet pivoted between the poles of the large magnet.

Remembering the law of magnetism which says that like poles repel, you can see that when the small magnet is in the position shown in Fig. 11A, there will be a repelling action which

rotates the small magnet in the direction indicated by the curved arrow.

## D. C. Milliammeter

In a practical d.c. milliammeter, we have exactly the same situation except that our imaginary small pivoted magnet is replaced by a pivoted meter coil or electromagnet like that shown in Fig. 11B, through which we send the current to be measured.

The meter coil is pivoted on tiny jewel bearings so it will turn easily. A pointer attached to the top of the coil sweeps over the meter scale. Delicate spiral springs hold the coil in a position which places the pointer at zero on the scale when no current is flowing.

**How a Meter Coil Acts.** When current is sent through the meter coil, the coil becomes an electromagnet. For one direction of electron flow through the coil, this electromagnet might have the polarity indicated in Fig. 11B, which is the same as the polarity of the small pivoted magnet in Fig. 11A. The coil will react in the same way as the pivoted magnet; that is, the coil will rotate *clockwise*, and make the pointer move to the right.

The greater the current sent through

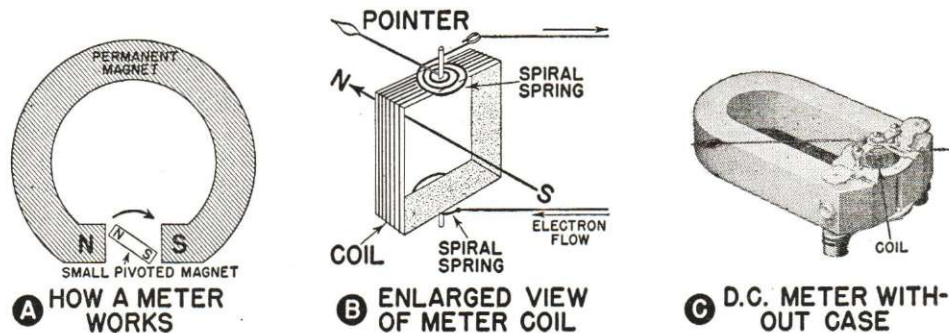

FIG. 11. How a d.c. milliammeter works, and what the inside of an actual meter looks like.

a meter coil, the stronger is the magnetic effect and the farther the coil rotates against the retarding action of the spiral springs. The meter coil always moves to a position at which the electromagnetic force which turns the coil is equal to the retarding force of the spring.

The divisions on the meter scale are spaced and numbered so the pointer will indicate the amount of current flowing through the meter coil.

**We Take a Meter Apart.** Figure 11C shows what you would see if you removed the case of a typical d.c. milliammeter. It should be pointed out, however, that radio men rarely if ever remove the case from a meter. Meters are even more delicate instruments than watches, and are easily damaged once the case is removed. Meters should be sent to the factory or to a meter repair expert when damaged.

**Uses for D.C. Milliammeters.** D.C. milliammeters are used by radio men to measure small values of direct current. Usually, milliammeters have coils which are designed to give a maximum (full-scale) reading for a current of 1 milliampere. Quite often, however, you will encounter milliammeters which are even more sensitive than this, and give full-scale readings on only a fraction of a milliampere.

**Warning!** Any current appreciably larger than the full-scale value of a milliammeter may damage the instrument. Excessively large currents will overheat the coil enough to melt the wire, and radio men then say that the meter is *burned out*.

Remember that whenever you use a milliammeter, make sure the current to be measured is within the safe current range of the meter.

**Second Warning!** Another equally important rule when using milliammeters is that a milliammeter must

always be placed *in series* with the circuit. In other words, you must actually cut into a circuit in order to connect a milliammeter properly. NEVER connect a milliammeter across a voltage source or across any part having a voltage drop, because this is almost certain to burn out the meter.

**Higher Meter Ranges.** Milliammeters and ammeters of all sizes employ essentially the same basic meter

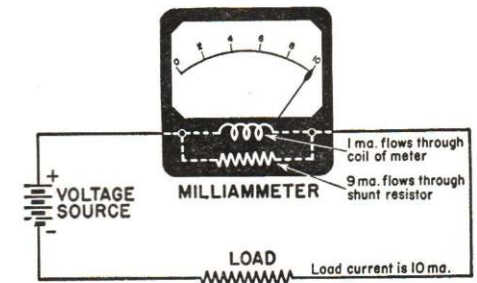

FIG. 12. This milliammeter, which reads currents up to 10 ma., is nothing more than a basic 0 to 1 ma. d.c. milliammeter with a shunt resistor.

construction illustrated in Fig. 11. Higher ranges are secured simply by adding to this basic meter a resistor which provides a short-cut or shunt path for some of the current being measured. The resistors used for this purpose are known as *shunts*, and are usually built right into the meter.

Figure 12 illustrates how a shunt is connected to a basic meter. By using various sizes of shunts with a basic 0 to 1 ma. d.c. milliammeter, you get milliammeters which can read from 0 to any higher maximum value such as 5 ma., 30 ma., 100 ma., or 500 ma. By using shunts still larger in dimensions, so that they have lower resistance and take a still greater portion of the current, you get ammeters which can read from 0 to any desired maximum current value in amperes.



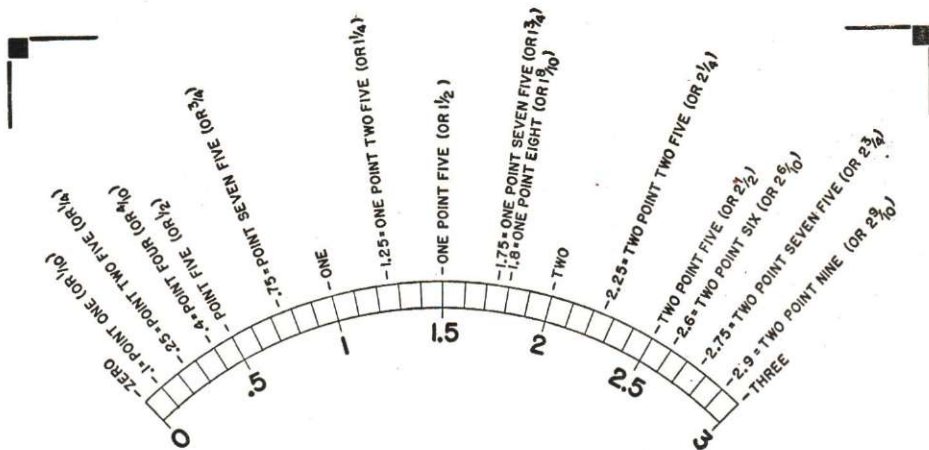

FIG. 13. The notes above this typical meter scale tell you what a radio man would read at various pointer positions. Figure out for yourself the value of each unmarked division line on the scale. Thus, the first line to the right of 1 is 1.1; the second is 1.2; the third (just past 1.25) is 1.3; the fourth (one line to the left of 1.5) is 1.4; etc.

**Polarity for Meters.** Radio men usually try to get the correct polarity the first time when connecting a d.c. milliammeter, because this saves quite a bit of time.

The correct polarity of connections for a milliammeter is such that the + terminal of the milliammeter goes to the + terminal of the voltage source, directly or through radio parts. The - terminal of the milliammeter then goes to the - terminal of the voltage source directly or through radio parts.

Just remember: *Plus to plus, and minus to minus.* This rule applies to d.c. ammeters, d.c. milliammeters and d.c. voltmeters.

If there is any doubt as to the correctness of a milliammeter connection, the radio man turns on the power for just a brief instant after making the connection and watches the meter pointer. If it starts to move backward (to the left of zero), he knows he must reverse the meter connections.

### Reading a Meter Scale

A careful study of the enlarged meter scale in Fig. 13 will give you a good start toward reading meters.

Once you understand what various pointer positions on this scale mean, you can apply your knowledge to practically any other meter scale which you may encounter in radio work.

**Marked Divisions.** When the pointer stops on a marked division such as .5, 1, 1.5, 2, 2.5 or 3, you simply read the printed number for that division line.

**Unmarked Divisions.** When the pointer stops on a small unmarked division, note the values of the marked divisions on either side, then figure out the value of the mark underneath the pointer just as you would figure out the value of one of the marks between 2 inches and 3 inches on a one-foot ruler.

**In Between Divisions.** If the pointer stops halfway between two unmarked divisions, determine the value of each of these unmarked scale divisions, then read a value halfway between them.

**Estimating is O.K.** It is entirely adequate in radio work to estimate meter readings roughly, when the pointer does not fall directly on a division line.

Study the diagram in Fig. 13 until you are sure you could give the value corresponding to each division line on this scale. The notes above the diagram will help you to determine what these values are and how they would be read by a radio man.

### D.C. Voltmeter

A d.c. voltmeter is nothing more than an ordinary d.c. milliammeter with a resistor placed in series with the meter coil.

This resistor uses up or drops a definite portion of the voltage being measured, and thus limits the current which can flow through the milliammeter.

**Multiplier Resistor.** The higher the resistance in ohms of a voltmeter resistor, the higher is the voltage range of the meter. The resistor in a voltmeter is usually called a *multiplier resistor*, for in a sense this resistor *multiplies* the useful range of the meter.

By using a printed scale made especially for use with the resistor in the meter, the pointer will correctly indicate the d.c. voltage which is being measured.

**Uses for Voltmeters.** Radio men use d.c. voltmeters to measure the d.c. voltages which exist between various tube electrodes and the chassis of a receiver, for these voltages are an important clue to trouble. In addition, d.c. voltmeters are used to check battery voltages, measure d.c. voltage drops across resistors and other radio parts, and for all other voltage measurements in direct current circuits.

**Polarity Is No Problem.** Although d.c. voltmeters must be connected with correct polarity before an accurate reading can be made, radio men ordinarily do not bother to figure out what the polarity is in case it is not marked.

They connect one voltmeter lead to the circuit, then tap the other voltmeter lead momentarily on the other circuit terminal while watching the meter pointer. If the meter pointer starts to move backward (to the left of zero on the scale), they disconnect the meter and reverse its connections.

**One Warning.** The important thing to remember when using a d.c. voltmeter is that the voltmeter range must be *higher* than the voltage being measured.

Whenever in doubt as to what a voltage may be, start with the highest-range voltmeter you have, and get a rough idea of what the voltage is before selecting a lower-range meter which gives a more accurate reading.

D.C. meters are built ruggedly



Courtesy Western Electric Co.

Meters tell this radio operator what's going on in each circuit, and thus help him to locate the defective tube or part speedily when trouble occurs. This transmitter is at the Springfield, Illinois, headquarters of the Illinois State Police radio system. It operates on a Federally-assigned frequency of 1,610,000 cycles (1610 kilocycles), which is only slightly higher than that of a broadcast station.



enough to stand considerable voltage overload. However, a voltage which is much too high for a meter may slam the pointer to the extreme right and bend it, or may even cause the meter coil to burn out.

### Ohmmeter

An ohmmeter is nothing more than a d.c. milliammeter with a small battery and a resistor mounted inside the meter and connected in series with the coil of the meter, essentially as shown in Fig. 14.

**Ohmmeter Uses.** An ohmmeter is used by radio men to measure the resistance values of resistors or other radio parts.

**Scale is Backward.** The commonest type of ohmmeter has a scale which reads from right to left, which is *backward* when compared to the other meters we have studied. In other words, zero ohms on the scale is at the extreme *right*, and the highest resistance value in ohms is at the left. A typical ohmmeter scale is shown on the meter in Fig. 14.

### Ohmmeter Zero Adjustment.

The resistor inside an ohmmeter is variable in value, and is adjusted by means of a knob or screwdriver adjustment so as to bring the pointer to 0 on the scale when the test probes are held together to give zero resistance. Since the ohmmeter battery voltage drops with use, the resistor must be adjusted from time to time. This is known as an *ohmmeter zero adjustment*, and takes only a few seconds to do.

**How an Ohmmeter Works.** When a resistor is placed between the test probes of the ohmmeter, this resistor reduces the amount of current which flows through the meter, and consequently the meter pointer takes a position somewhere on the scale. (Remember that the meter itself is still

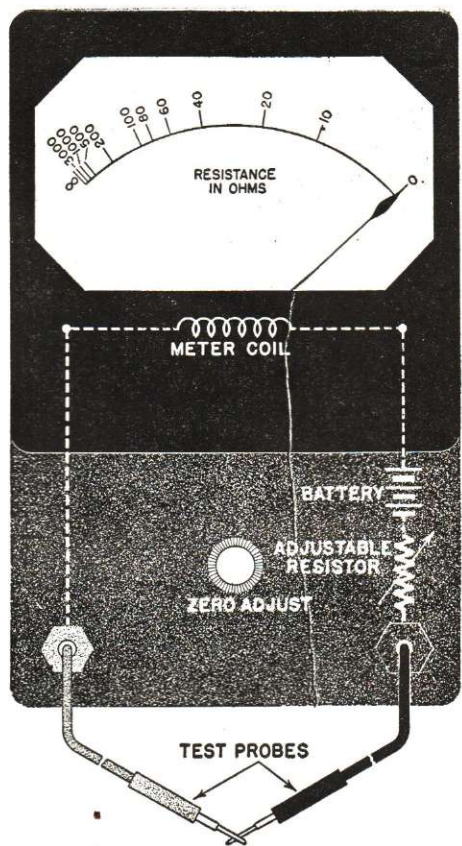

FIG. 14. Put a resistor and battery of the correct values in series with the coil of a d.c. milliammeter, and you have an ohmmeter for use in measuring resistance values. Polarity does not ordinarily matter when using an ohmmeter.

our basic d.c. milliammeter, with its pointer dropping to the extreme left when current is zero.)

The higher the value in ohms of the resistor being measured, the greater will be the total resistance in the ohmmeter circuit, the lower will be the current flowing through the circuit, and the closer to the left end of the scale will be the meter pointer. This is why resistance values on the scale of an ohmmeter must be zero at the extreme right and must increase gradually toward the left.

**What Infinity Means.** When the

test probes are apart, there is an *open circuit*. This is the same as having an *extremely high resistance* between the ohmmeter terminals. Under this condition, no current flows through the meter, and the pointer drops to the extreme left. We say that the resistance is then *infinitely high*, which means that it is the highest value it is possible to think of—many million million ohms. Sometimes we use the symbol  $\infty$ , called *infinity*, at the extreme left on the meter scale to designate an infinite resistance.

**Warning.** An ohmmeter must never be used in a circuit in which a voltage exists. Apparatus should always be disconnected from its power source before the ohmmeter is used. The ohmmeter has its own voltage source, and sends its own current through the part to be measured. Any additional voltage in the circuit would send extra current through the ohmmeter, possibly ruining the meter coil.

### A.C. Milliammeter

The a.c. milliammeter used most often in radio work is nothing more than an ordinary d.c. milliammeter with one additional part called a *rectifier*. This rectifier is a tiny unit mounted inside the meter case, and has the job of changing the alternating current being measured into a direct current. The d.c. milliammeter responds to this direct current, but its scale is made to read in terms of the alternating current being measured.

**Shunts.** The ranges of a.c. milliammeters are increased by using shunts, just as with d.c. milliammeters. These shunts are usually built right into the instrument.

**What the Meter Reads.** You will recall that an alternating current is one which varies continually from a maximum value flowing in one direc-

tion to a maximum value flowing in the opposite direction. What is the a.c. milliammeter going to read in a case like this?

Here is the answer—the meter reads the a.c. current value which will produce the same amount of heat as the corresponding direct current value. Thus, an alternating current of one ampere will produce *the same amount of heat* as a direct current of one ampere.

### A.C. Voltmeter

If you take an a.c. milliammeter and place a resistor in series with everything else inside the instrument, you have an *a.c. voltmeter*. The value of the resistor determines the range of the voltmeter.

**Uses.** A.C. voltmeters are used by radio men for checking the a.c. power line voltage, the filament voltages of tubes, and the various voltages across the secondary windings of the power transformer in a receiver or other piece of radio equipment. A.C. voltmeters are sometimes also used for measuring audio signal voltages.

**What the Meter Reads.** You will recall that an a.c. voltage is one which varies continually from a maximum value acting in one direction to a maximum value acting in the opposite direction. What is the a.c. meter going to read in this case?

The answer here is the same as for current—the meter reads the a.c. voltage value which will do just as much useful work as the corresponding d.c. voltage value. We call this a.c. voltmeter reading the *effective value* of the a.c. voltage. It so happens that the effective value of an a.c. voltage is equal to about seven-tenths of the maximum a.c. voltage acting in either direction.

**Effective Value of Voltage.** All you need to remember is that a.c. volt-



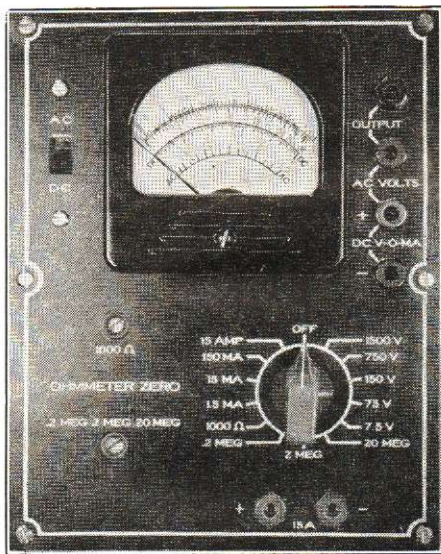

FIG. 15. Multimeter section of a typical professional all-purpose tester used by Radio-tricians.

meters measure the *effective* value of an a.c. voltage. The a.c. voltages you will deal with are effective values unless otherwise specified. Thus, if you have an ordinary a.c. power line coming to your home, its 115-volt value is an effective value, and the voltage actually reaches about 165 volts during the peaks of each cycle.

### Multimeters

Since every one of the meters ordinarily used in radio work consist of a d.c. milliammeter used alone or with resistors, rectifiers, shunts or batteries, it is only logical to make a single d.c. milliammeter serve for all purposes. This can be done by means of a switching arrangement which automatically connects the correct parts to the meter for a particular measurement. The resulting many-purpose instrument is known under various names, such as a *multimeter*, an *all-purpose tester*, a *multi-tester*, or a *volt-ohm-milliammeter*.

**All-Purpose Tester.** A typical ex-

ample of an all-purpose tester used by radio men is shown in Fig. 15. This one instrument is equal to twenty different separate meters, including five d.c. voltmeters with different ranges, five different a.c. voltmeters, three different d.c. milliammeters, one d.c. ammeter, four different ohmmeters and two different audio output voltage meters. This tester is thus capable of making practically all of the measurements required by radio men.

To prepare this all-purpose tester for use as a particular type of meter,

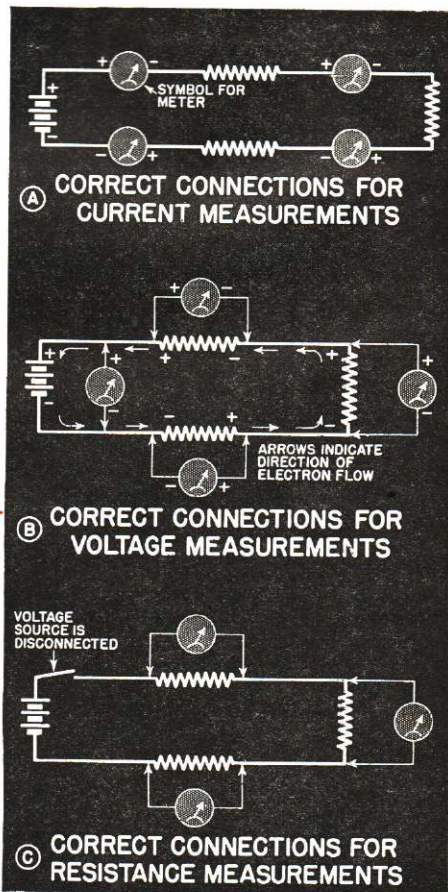

FIG. 16. Reference chart showing correct meter connections for current, voltage and resistance measurements and correct polarity for d.c. measurements.

all you need do is plug the test leads into the correct jacks on the panel, then set the two switches to the correct positions for the type of meter and range desired. Each jack and switch is clearly marked, so this can be done without even referring to an instruction book.

The meter in this tester has four scales. One serves for all d.c. readings, another for all a.c. readings, and the remaining two are used for the ohmmeter ranges. The two ohmmeter zero adjustments are of the screwdriver type, and are located at the lower left of the meter.

When the switch at the left of the meter is in its a.c. position, a rectifier is automatically inserted in the meter circuit for a.c. measurements. When this switch is in the d.c. position, the rectifier is disconnected.

Although for convenience and clarity we usually show individual meters in lessons, remember that a radio man

would normally use a multimeter or all-purpose tester for a measurement.

### Summary of Meters

The three important rules you should keep in mind whenever making meter measurements are:

1. For current measurements, always break into a circuit, so that the meter is in series with the circuit. This rule is illustrated in Fig. 16A. The current measurement can be made at any one of the four meter positions shown in this diagram.

2. For voltage measurements, connect to the points across which is the voltage to be measured. This rule is illustrated in Fig. 16B.

3. For ohmmeter measurements, connect *across* the resistance to be measured, but be sure to disconnect all batteries or other voltage sources, so no voltage exists in the external circuit. This rule is illustrated in Fig. 16C.

## Voltage Sources for Radio Circuits

Since every radio circuit must have a *voltage source* of some kind, a general knowledge of the different kinds of voltage sources is highly desirable.

Many of the voltage sources used in radio are quite simple and familiar to most people. You may already know quite a bit about dry batteries and storage batteries, but even if you don't, you will undoubtedly find them easy to study.

The sections on d.c. and a.c. generators will particularly help you with radio work, because they give you a clearer understanding of what a.c. and d.c. voltages are like.

### Batteries

**Uses.** Dry batteries are used in battery-operated farm radios, in port-

able radio receivers, in the portable two-way radiophone sets of the Army and the U. S. Forest Service, in radio test instruments and in many other types of radio equipment. Storage batteries are the main voltage sources for radio equipment in airplanes, boats, automobiles, and other large mobile units. Thus, batteries are still used enough in the field of radio to make a general knowledge of their construction and connections desirable.

**Two Types.** Two distinct types of units or *cells* are used in batteries: 1. *Primary cells*, which are used in dry batteries, and cannot be recharged when exhausted; 2. *Secondary cells*, which are used in storage batteries, and can be recharged.





FIG. 17. Construction of a standard dry cell.

Both primary and secondary cells produce a d.c. voltage by chemical action, and supply direct current. Scientists would say that both types of cells convert chemical energy into electrical energy.

### Dry Cells

The *dry cells* generally used in portable radio receivers and in flashlights are perhaps the best known examples of primary cells. The chemical materials in a dry cell are gradually used up when current is drawn from the cell. When the supply of the chemical material is exhausted, the useful life of the cell is ended, and the cell must be replaced.

**Construction.** The construction of an ordinary dry cell is shown in Fig. 17. Flashlight cells are made in much the same way, but are smaller. In a flashlight cell, the negative connection is made *directly* to the exposed zinc case at the bottom of the cell,

instead of to a top terminal attached to this case.

**Voltage Produced.** All ordinary dry cells deliver the same voltage of slightly over  $1\frac{1}{2}$  volts (1.5 volts) when new. This voltage drops during use, and the cell must be replaced when its voltage becomes too low for its intended purpose.

**Current Furnished.** The larger the physical dimensions of a dry cell, the greater the amount of current it can deliver, or the longer it can deliver some definite value of current.

**Dry Cells in Series.** When a voltage higher than  $1\frac{1}{2}$  volts is required, dry cells are connected together in series until the desired voltage is obtained. In this series connection, the  $-$  terminal of one cell goes to the  $+$  terminal of the next cell. You would connect cells together in series whenever you needed a voltage equal to the sum of the individual cell voltages.

For example, when a voltage of 45

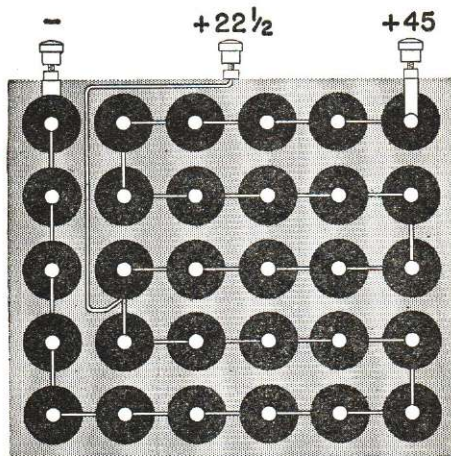

FIG. 18. How 30 dry cells are connected together in series to make a 45-volt B battery.

volts is desired, thirty individual dry cells are connected together in series in the manner shown in Fig. 18. This arrangement gives us a 45-volt B bat-

tery, of which a cut-away view is shown in Fig. 19.

**Dry Cells in Parallel.** When you require more current than it is desirable to draw from a single cell, you can connect additional cells *in parallel*. Each cell then furnishes its share of current to the load, so you increase the current-furnishing capacity without affecting the voltage. Examples of parallel connections are shown in Fig. 20.

**Remember This.** When you want



FIG. 19. Part of this 45-volt radio B battery has been cut away to show some of the individual dry cells.

to get the greatest possible voltage from a group of dry cells, connect them together *in series*. When you want to get the greatest possible current or the longest life from a group of dry cells, without any more voltage than is provided by a single cell, connect them together *in parallel*.

**Series-Parallel Connections.** When both higher voltage and higher current-delivering ability are desired, a series-parallel connection can be used. This involves connecting one group of cells together in series until it has the desired voltage, then connecting



FIG. 20. Parallel connections of dry cells. Remember that when cells are connected together in parallel, the voltage is that of one cell, but the current-furnishing ability is increased.

this group of cells in parallel with two or more similar groups of cells until the desired current-handling ability is obtained. Examples are shown in Fig. 21.

### Storage Batteries

The *storage battery* used in automobiles is the best-known example of a battery using rechargeable secondary cells.

**Construction.** A storage cell has two groups of plates, one group attached to the positive terminal and the other group attached to the negative terminal. These positive and negative groups of plates are made of lead (the metal, pronounced *LED*), and fit together alternately in the manner shown in Fig. 22A. Each plate has holes filled with the active chemical material of the cell, which is in paste form.

Between the plates are sheets of insulating material called separators, made either from porous wood or perforated rubber (Fig. 22B). Separators prevent the plates from touching each other and short-circuiting the cell.

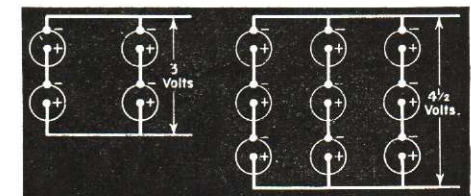

FIG. 21. Examples of series-parallel connections of dry cells.



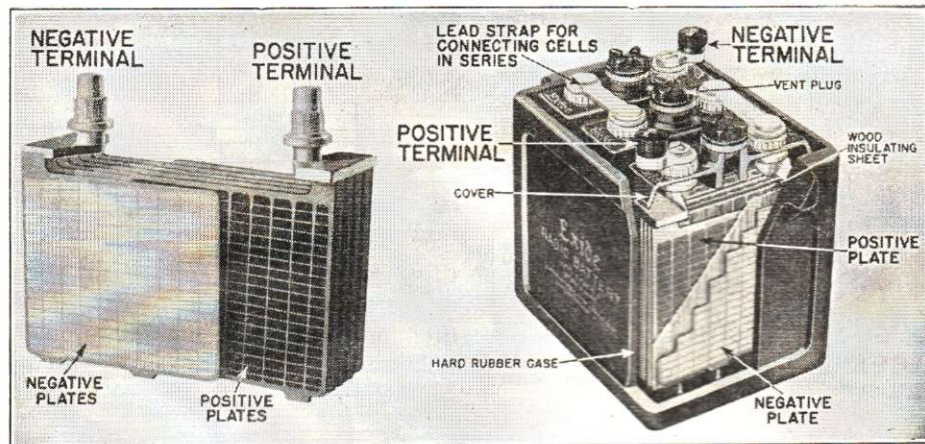

FIG. 22A. How the two groups of plates in a storage cell fit together. Insulating sheets prevent adjacent plate from touching.

**Hydrometer Test.** The plates of a storage cell are suspended in a container filled with a solution of sulphuric acid and pure water. The amount of sulphuric acid in the solution is an indication of how much the cell is charged (how much energy it contains in chemical form). The device shown in Fig. 23, called a *hydrometer* (pronounced *hie-DRUM-shur*), is used to test the charge of a storage battery.

**Recharging.** The chemical materials change gradually to inactive forms when electrons flow out of the negative terminal of a storage battery during use. A storage battery is recharged by properly connecting it to a d.c. voltage source having a higher voltage than the storage battery. Charging is completed when the resulting reversed current has changed all of the chemical materials back to their original form.

**Voltage Produced.** The voltage of a storage cell is about 2 volts, and changes very little with use. For automotive purposes, three storage cells are connected in series, so that

FIG. 22B. Cut-away view showing the construction of a typical 6-volt storage battery, which contains three storage cells connected in series.

their voltages add together to give the required 6 volts.

Storage batteries used for radio equipment in boats and airplanes often have six cells in series, to give 12 volts. The new tiny spill-proof storage batteries designed for portable radio receivers have only one cell, and hence deliver only 2 volts.

### Generators

The majority of radio receivers in use today operate from wall outlets



FIG. 23. A hydrometer like this is used to test the condition of each cell in a storage battery. A fully charged battery will give a reading of about 1.280, and a discharged battery will give a reading of about 1.120.

which furnish either a.c. or d.c. voltage. Behind each wall outlet is a complicated network of power lines which eventually leads to a central power station. Here steam turbines or water wheels turn huge generators which can supply thousands of amperes of current. Most of these power plants produce a.c. voltage, but there are still a few, in the older sections

of force extending from the N pole to the S pole.

The coil of wire is mounted between the poles of the magnet in such a way that it can be rotated. Connections are made to the two ends of the coil by means of *slip rings* and *brushes*, as illustrated in Fig. 24. The copper slip rings are mounted on the shaft but insulated from it. The

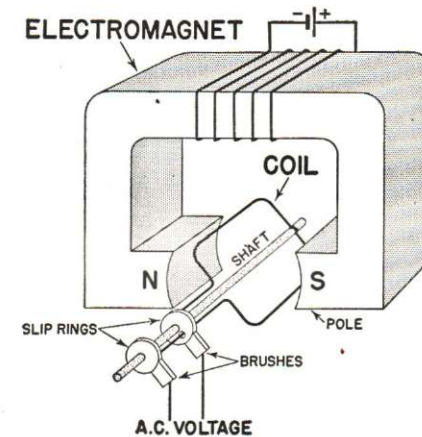

FIG. 24. Simple a.c. generator. Yes, it works!

of large cities, which generate d.c. voltages for home and business use.

A general idea of how these a.c. and d.c. voltages are produced is well worth while, because it will help you to understand how these voltages affect radio circuits.

### A.C. Generator

In its simplest form, an alternating current generator has only the two essential parts pictured in Fig. 24, an *electromagnet* and a rotating coil.

**Construction.** The electromagnet in this elementary generator is a horseshoe-shaped iron piece which is magnetized by a coil of wire connected to a d.c. voltage source. The electromagnet produces magnetic lines

brushes are blocks of carbon which are mounted in fixed holders. The brushes slide easily against the slip rings as the shaft rotates, and provide a complete path for electrons from the coil to any loads which are connected to the generator terminals.

**Operation.** When the coil is rotated, the number of magnetic lines of force which pass through the coil changes continually. This causes a voltage to be generated or induced in the coil.

**Polarity.** During one half of each complete revolution or turn of the coil, this voltage acts in one direction. During the other half of a revolution, the voltage reverses its *polarity* and acts in the other direction.



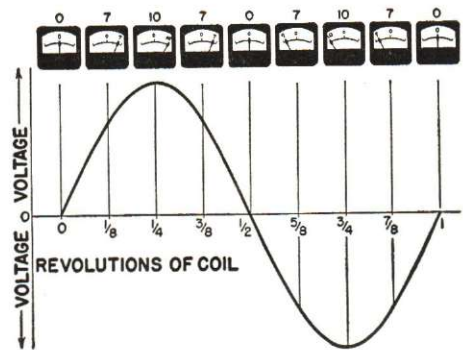

FIG. 25. One cycle of the voltage produced by a simple a.c. generator can be represented by the curve shown here. If the generator were being turned slowly enough so a zero-center d.c. meter could follow its variations, the meter readings at nine different coil positions during a complete revolution of the generator coil would be as shown here.

If we connect between the brushes of our simple a.c. generator a special type of d.c. meter which has zero at the center of its scale, and take photographs of the meter at each 1/8 revolution while turning the coil slowly, the meter photographs might appear as shown across the top of Fig. 25. These photographs give a good idea of how the voltage is varying both in value and polarity, so let's study them a bit.

During the first half-revolution of the coil (from 0 to 1/2), the meter pointer moves from 0 to the extreme right, and then back to 0. During the second half-revolution, the generated voltage has reversed its polarity, and the meter pointer moves from 0 to the extreme left and back to zero again.

**Graph for an A.C. Generator.** Now, if we changed these meter readings into the type of simple graph used by radio men, we would secure a curve like that in Fig. 25. Distances up or down from the horizontal line represent voltage values at different instants of time (at different parts of a complete revolution). The curve is above the horizontal line for one po-

larity, and goes below the line when the voltage reverses its polarity.

**One Cycle.** One complete revolution of our simple generator coil produces one cycle of a.c. voltage. For each additional revolution, the voltage changes would repeat themselves in the same way as shown for the first revolution in Fig. 25. Consequently, the curve represents one cycle of our a.c. voltage.

**60-Cycle Power.** If we turn our simple generator fast enough so it makes 60 complete revolutions in one second, there will be 60 of these voltage cycles per second, and we will have 60-cycle electric power like that used in most sections of this country.

When a generator is rotated fast enough to produce 60 voltage cycles each second, no ordinary meter can follow the instantaneous voltage varia-

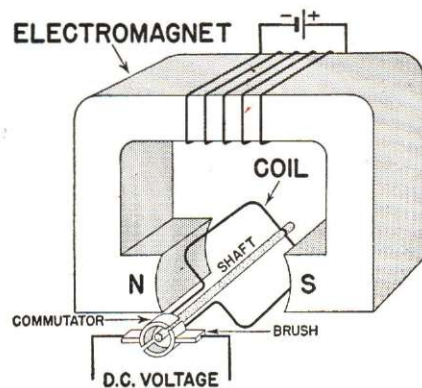

FIG. 26. Simple d.c. generator. It'll work, too! tions in each cycle. A cathode ray oscilloscope can follow fast changes, however, and for one cycle of a 60-cycle voltage it would show on its screen exactly the same curved pattern shown in Fig. 25.

### D.C. Generator

A direct current generator is nothing more than an a.c. generator with a commutator in place of slip rings, as

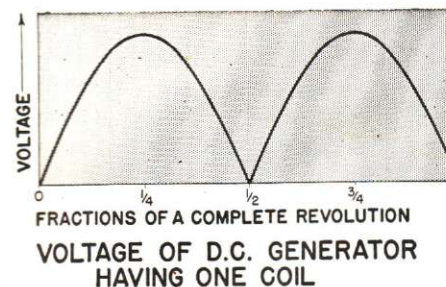

FIG. 27. Example of a diagram which might be used by radio men to show how the voltage of a simple d.c. generator varies during one complete revolution of the coil.

shown in Fig. 26. A commutator is a device which automatically reverses the connections between the generator and its load at the exact instant during each revolution when the generated voltage begins reversing its polarity.

**Polarity.** The automatic reversal of connections by the commutator makes the terminals of a d.c. generator have the same polarity at all times. As a result, a diagram showing the volt-

age between the brushes of a d.c. generator during one complete revolution would appear as in Fig. 27.

**Actual Construction.** In an actual d.c. generator such as would be used in a power plant and in certain types of radio equipment, there are many coils mounted on the rotating shaft of the generator, instead of just one coil. When the voltage in one coil is dropping, the voltage in another coil is rising, and the voltages add together to give an almost constant d.c. voltage.

**Filter.** Even a small variation in d.c. voltage is objectionable in certain types of radio equipment, but this variation can be removed with a filter made up of coils and condensers.

**Field Current.** In commercial a.c. and d.c. generators, the electromagnet coil is known as the field coil because it provides the magnetic field.

In a d.c. generator, some of the direct current produced by the generator

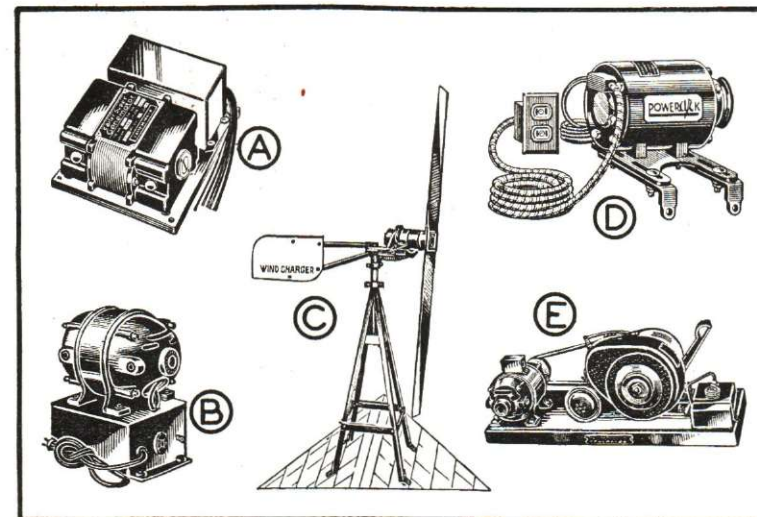

Examples of generator units used with radio equipment. ♦A—Dynamotor, a combination motor and generator operating from a 6-volt storage battery and generating the high d.c. voltages required by police radio equipment or public address amplifiers. ♦B—Dynamotor which changes 32 or 115 volts d.c. to 115 volts a.c. ♦C—Wind-driven generator used for charging storage batteries of farm radios. ♦D—115-volt a.c. generator which can be driven by the fan belt of an automobile or truck. ♦E—Combination 115-volt a.c. and 6-volt d.c. generator driven by a gasoline engine, used with high-power portable radio equipment.



is used for the field coil, thereby eliminating the need for a battery.

A commercial a.c. generator always has a small d.c. generator mounted on its shaft or built right into the a.c. generator housing, to produce the di-

rect current required for the field coils of the a.c. generator.

### Looking Ahead

The general knowledge of radio broadcasting and receiving which you gained from the first two lessons of your Course has now been reinforced by the highly practical information in this lesson.

You have learned a great deal about voltage, current and resistance in radio circuits. You have a working knowledge of voltage source, load and meter connections. You are familiar with the different kinds of voltage sources used in radio work.

You are ready, therefore, at this early point in your N.R.I. Course to take up a typical modern superheterodyne radio receiver. In the next lesson, you will find out what this receiver is like, how it is operated, what each part is, why and how the parts might fail, and what radio men would do to repair the receiver when various parts fail.

Not only will this next lesson prove clearly the importance of the material you have already studied, but it will carry you right ahead to still more interesting and more practical work. You will actually be learning some of the different ways of repairing receivers and radio parts.

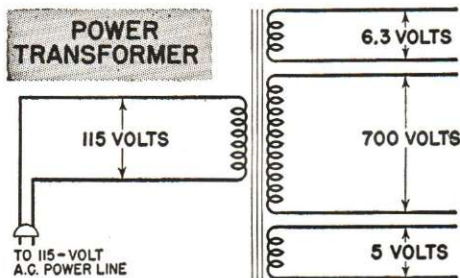

FIG. 28. Diagram of a power transformer similar to those used in a.c. radio receivers.

rect current required for the field coils of the a.c. generator.

### Transformers

In a.c. circuits, the problem of securing a desired a.c. voltage value is greatly simplified because we can change an a.c. voltage to any desired higher or lower value by means of a transformer.

Here is a practical example: A radio receiver which is to operate from a 115-volt a.c. power line requires 5 volts for the filament of the rectifier tube, 6.3 volts for the filaments of the other tubes, and 700 volts for the power pack which is to furnish d.c. voltages to the various tube electrodes.

The power transformer for this receiver will have one primary winding

## Lesson Questions

Be sure to number your Answer Sheet 3FR-2.

Place your Student Number on every Answer Sheet.

Send in your answers for this lesson immediately after you finish them, as instructed in the Study Schedule. Do this, and get the greatest possible benefit from our speedy personal grading service.

1. What type of voltage reverses its polarity regularly?  
*AC*
2. Name the unit of current which is equal to one thousandth of an ampere.  
*1 MA*
3. If you want to reduce the amount of direct current which is flowing in a radio circuit, what radio part should you insert in the circuit?
4. If you increase the source voltage in a complete radio circuit, what will happen to the current?
5. If you decrease the resistance in a complete circuit, what will happen to the current?  
*INCREASE*
6. In what way would you connect together the filaments of radio tubes if all the filaments required the same current, and the available voltage was equal to the SUM of all the filament voltage ratings?  
*PARALLEL*
7. When can the filaments of radio tubes be connected in parallel?  
*WHEN THEY ALL REQUIRE THE SAME VOLTAGE*
8. Will the voltage drops across the resistors in this series circuit add up to a value LESS THAN, EQUAL TO, or MORE THAN the 45-volt source voltage?  
*LESS THAN EQUAL TO*
9. What reading is indicated by the pointer on this voltmeter scale? (Study Fig. 13 carefully before you answer this question.)  
*1.4*

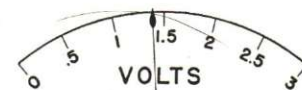
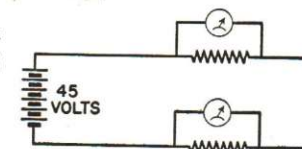

10. Tell how you would connect four 1½-volt dry cells together to get a total voltage of 6 volts?  
*SERIES*





## GETTING YOUR "SECOND WIND"

After an opening burst of speed, a champion long-distance runner drops down to a steady natural pace. This brief period of relaxation releases that reserve of power called "second wind." He is then able to overtake and pass the now nearly exhausted leaders in the race.

No matter what you are doing, you also can do it better once you get your *second wind*. Instead of fighting that sleepy feeling which sometimes comes when you are studying, stop and relax for a few minutes so as to release your own supply of reserve power. Here are some ways to relax, all worth trying.

Get up and exercise for a few minutes. Get a drink of cold water. Step outside for a few *deep* breaths of fresh air. Take a brisk walk up and down the road or once around the block.

If you "shake yourself awake" in one of these ways, you'll find it isn't at all hard to get that second wind which enables you to study longer and makes the going easier. Then you'll get in some real worthwhile studying—then you'll get things done!

*J. E. Smith*