

**HOW TO ISOLATE  
THE DEFECTIVE CIRCUIT  
AND PART**

38RH-2

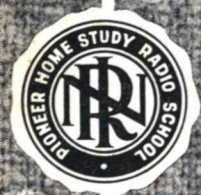

**NATIONAL RADIO INSTITUTE**

**WASHINGTON, D. C.**

**ESTABLISHED 1914**

# STUDY SCHEDULE NO. 38

For each study step, read the assigned pages first at your usual speed. Reread slowly one or more times. Finish with one quick reading to fix the important facts firmly in your mind. Study each other step in this same way.

1. Analysis of the Defective Circuit . . . . . Pages 1-8

Once you get the trouble pinned down to a particular stage in a receiver, a few minutes study of the circuits for that stage will often suggest one or two simple tests which will lead you directly to the defective part. A number of actual examples in this section show you exactly how to use effect-to-cause reasoning for this purpose in various types of circuits.

2. Isolating the Defective Circuit and Part . . . . . Pages 9-14

There will be plenty of jobs in which effect-to-cause reasoning fails to point out the defective part: Isolating procedures then come next, and you can choose between the methods for which general rules are given in this section. The electrode voltage test uses an ordinary d.c. voltmeter to check the d.c. voltage at each tube electrode, and the electrode continuity test uses an ohmmeter to check the continuity between tube electrodes and reference terminals in the power pack.

3. Examples of Part-Isolating Tests for Power Line Receivers . . . . . Pages 14-22

Basic circuits used in standard a.c., transformerless a.c., and universal a.c.-d.c. receivers are used as examples to show how electrode voltage tests and electrode continuity tests are used to isolate the defective part in a stage. Study the examples carefully, being sure you understand *why* each conclusion holds true, so you can interpret your own meter readings in a similar manner. A meter is of no value whatsoever unless you understand the story each meter reading has to tell.

4. Examples of Part-Isolating Tests for Battery and Vibrator Receivers . . . . . Pages 23-28

The large number of battery-operated portables, farm receivers and auto sets make this an important section. Many important rules are brought out which can be applied to all types of receivers. You will learn that the basic testing procedure is practically the same as is used for power line sets, except for variations introduced by the power supply.

5. Answer the Lesson Questions and Mail Your Answers to N.R.I.

6. Start Studying the Next Lesson.

## HOW TO ISOLATE THE DEFECTIVE CIRCUIT AND PART

### Analysis of the Defective Circuit

THE professional servicing technique covered so far is planned to isolate the defect, first to one section (r.f., i.f., a.f., etc.), and then to one stage in that section. We thus narrow the trouble down to the few closely related parts that contribute to the operation of a single stage in a radio receiver.

In this lesson you are going to learn how to isolate, within the stage, the part that is actually defective and preventing normal operation. This is the objective of all radio servicing since as soon as the defective part is identified, it can be replaced and normal operation restored. Successful servicing means nothing more or less than finding that defective part with professional sureness and swiftness.

The methods you will learn in this lesson for finding that defective part are first, going directly to it by what we have called "effect-to-cause" reasoning, and second, running the part down by specific tests that lead from one symptom to another until the fault is isolated. The actual, practical examples of parts isolation tests to be given later in the lesson will enable the serviceman to handle a large majority of the defective receivers that make up the day-to-day work-load on any service bench.

will be attested to by every successful serviceman—analysis is far quicker and in radio servicing, time is all-important. Instruments are always at hand to uncover additional symptoms if analysis fails. But if you learn to go directly to the trouble from the symptoms, it means that a major part of your time and labor will be saved.

Analysis is particularly useful when the trouble has been isolated to a single stage. It is much simpler to visualize clearly what is going on in a single stage than in all the sections of a complex receiver. It should be clear by now

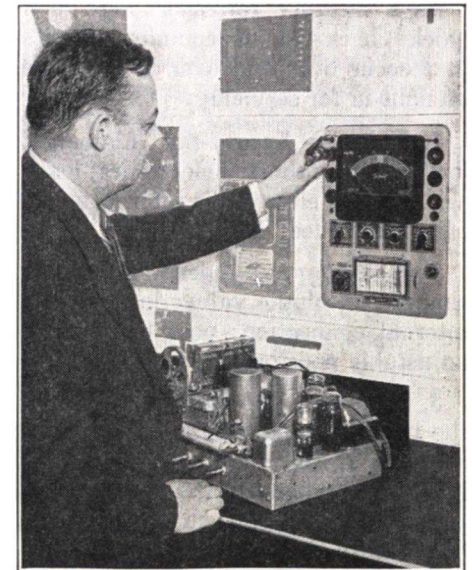

#### ISOLATING THE DEFECTIVE PART BY ANALYSIS

One may ask, why try to find the defective part by analysis? The answer

One of the first steps in a service job is looking for surface defects. Tubes are usually checked at this time, as they make up a large percentage of the service complaints and the customer expects this service.

why you should frequently go back and review the lessons on basic theory whenever you get the chance. The more you get the real "feel" of what goes on in the various circuits of a radio receiver, the quicker and more accurate your analysis of defects is going to be.

The experience of all who study radio is that reviewing theory, the "how-it-works" parts of the course, from time to time after you have practical experience, is a sure way to make the theory vivid and real to the mind. Of course, you must get the fundamentals in the very beginning, but going back over them again will deepen your understanding of the "why" of each circuit and part in a radio. The real emotional satisfaction in radio comes from being thoroughly at home among the complex techniques of this fascinating, ever-expanding science. And this knowledge is one of your most important tools as a serviceman!

As a memory refresher, here is a quick check-list of common defects that occur over and over in receivers brought in for servicing:

1. *Tubes* — burned-out filaments; low emission; shorted electrodes; leakage between electrodes; intermittently open electrodes; gas.

2. *Resistors* — open; shorted; changed in ohmic value; intermittent internal connection; poor contacts in adjustable resistors.

3. *Coils* — open; shorted; some of the turns shorted together; poor connections at terminals, lugs or leads; leakage or ground to the core in iron-core units; intermittent or complete open due to electrolysis.\*

4. *Condensers* — open; shorted; leaky; loss in capacity; high-power open; intermittent open.

5. *Connections* — open; shorted

leads; leakage between leads; intermittent or noisy connections (due to corrosion, thermal action, internal arcing or chassis vibration).

6. *Alignment*—this will be taken up elsewhere in the Course.

You will note three principal types of defects in the above list—shorts, opens, and changes in value. Poor connections and leaks are special cases of opens and shorts. In nearly every case, these defects will change the normal voltage, resistance and current relationships in the stage. That change is the symptom we look for, by means of a voltmeter, ohmmeter, or other instrument. After the discussion of analysis methods, we will learn the standard testing procedures for finding the defective circuit and part in any type of receiver by means of such tests. For our general discussion of "effect-to-cause" reasoning, applied to isolating the defective part within a stage, let us now consider the pentode detector circuit shown in Fig. 1. For purposes of analysis, we can "lift out" the i.f., a.f., and supply circuits as shown in Figs. 2, 3 and 4 respectively. By studying the normal paths, we can see just how a defect in any part will affect the circuit in which it operates. Some parts will affect more than one circuit, so they will be covered under the circuit where their defects are most noticeable. You should refer back to Fig. 1 from time to time, to get an overall picture of the stage operation, as the manufacturer's diagrams do not break the circuit down this way. You will have to do your own analyzing when servicing.

\*Electrolysis is the action which occurs whenever currents cause corrosion by flowing in and out of the surface of a conductor due to resistance developing in a joint or to conductivity in adjoining insulation. The corrosion causes green spots on the copper wire and will eventually break the wire at this point.

## I.F. SIGNAL CIRCUITS

Starting with the i.f. signal circuits of Fig. 2, we have a signal voltage coming in from the preceding i.f. stage. The i.f. plate current of the last i.f. amplifier tube flows through primary  $L_1$  of the i.f. transformer, inducing in the secondary  $L_2$  a corresponding i.f. voltage. This voltage undergoes resonance step-up. Then the voltage across  $C$  is applied across the grid and cathode of the detector tube, reaching the cath-

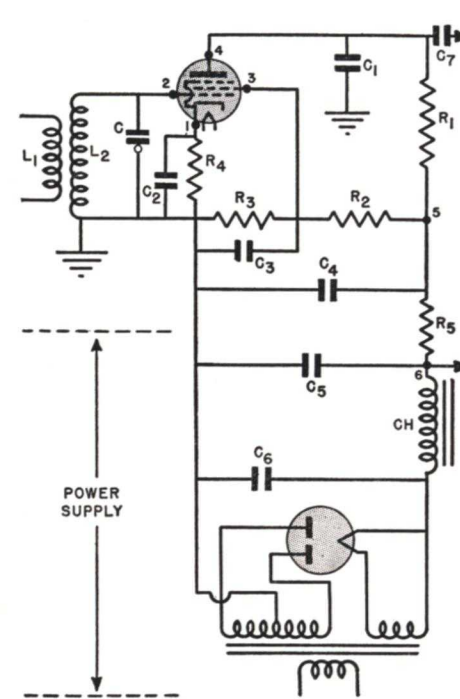

FIG. 1. This typical pentode C-bias detector stage is a good example of combined r.f., a.f. and power circuits.

ode through condenser  $C_2$ , which is a by-pass condenser for i.f. currents. The i.f. signal is carrying with it an a.f. component which represents the voice or music we want to hear. It is the job of the tube to separate the two. It accomplishes this "rectification" because cathode resistor  $R_4$  provides a C bias voltage which makes the tube operate

at the plate current cut-off point. Negative half cycles of the incoming i.f. signal have no effect on plate current because the grid is already so far negative due to the bias that the tube is in "no operation" condition. Positive half cycles counteract the bias voltage and allow pulses of plate current to flow. These pulses have both the i.f. and a.f. components in such form that the a.f. can be separated and sent on to

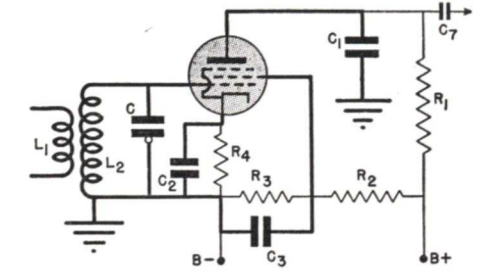

FIG. 2. The r.f. circuits of Fig. 1 are shown here by heavy lines. Refer back to Fig. 1 to see their relationship to other circuits.

the audio amplifier. Condenser  $C_1$  assists this separation, by-passing the i.f. currents to ground, where they travel back through  $C_2$  to the cathode.

Actually, the plate i.f. circuit is a series circuit, consisting of condensers  $C_1$  and  $C_2$ , and the internal tube plate-cathode impedance. Because  $C_1$  and  $C_2$  both have extremely low reactances at radio frequencies, the internal tube impedance is by far the highest, and hence most of the plate i.f. voltage is dropped in the tube.

Screen grid by-pass condenser  $C_3$  keeps the screen at i.f. ground potential so there is practically no r.f. voltage between screen and ground while this condenser is good. The screen then acts as an electrostatic shield between the plate and control grid, thus preventing i.f. voltage on the plate from feeding back to the control grid. Con-

denser  $C_2$  serves as a return path to the cathode for screen grid i.f. current by-passed by  $C_3$ , as well as plate i.f. current by-passed by  $C_1$ .

This analysis indicates that normal flow of i.f. signal current can be interrupted by a defect in any one of these parts, and we can proceed to study what happens to the operation of the stage with a defect in each one. This will enable us to reason back to the defect when we encounter the symptoms that are associated with it. However, certain defects in i.f. signal circuit parts may be easier to find from the effect on the supply or a.f. circuits. Hence, troubles will be covered here under the conditions where they are easiest to find.

**$L_2$  Open.** With a break in the windings of  $L_2$ , the i.f. voltage induced could not send a signal current around the resonant circuit  $L_2-C$ . Hence, there would be no signal voltage developed across the circuit to pass on to the tube and the stage would ordinarily be dead. Whatever technique of isolating the dead stage you used would bring you to the grid circuit of the detector as the point where normal operation ceased. A signal tracer would show a signal across  $L_1$  but none across  $L_2$  or  $C$ ; this would indicate a break in  $L_2$ . A signal across  $L_2$  but none across  $C$  would indicate a broken lead between the two.

**$C_1$  Open.** Condenser  $C_1$  is used to by-pass the i.f. components in the plate circuit of the tube to ground, as explained above. An open condenser is the same as if the condenser was not there, so an open  $C_1$  would permit the i.f. components to enter and probably overload the following a.f. amplifier, causing distortion. Also, since the condenser will normally by-pass a portion of the very high audio frequencies, the tone quality will be more "tinny" than normal. You would have to be familiar

with the normal tone quality of the set to notice this, of course.

The possibility of this condenser being defective probably would be overlooked until the trouble has been localized to this stage. Even then, leakage in coupling condenser  $C_7$  would be suspected first, particularly since the distortion may appear in the first audio stage more definitely than here.

A signal tracer is the quickest way of confirming your analysis of this defect, since if the i.f. signal appeared between the detector plate and ground where it is definitely supposed to be absent, an open in  $C_1$  is indicated. Shunting the suspected condenser with a good one is another quick way of checking your analysis. If the distortion and tinyness clear up when the leads of the test condenser are touched across the old one, the fault is located.

### A.F. SIGNAL CIRCUITS

Let us see what constitutes the a.f. signal path, what parts are in the path, and how defects in those parts affect operation. The audio circuits are shown by heavy lines in Fig. 3. The plate-cathode path inside the tube is the source of a.f. voltage, and the a.f. current flows from plate to cathode through  $R_1$ ,  $C_4$  and  $C_2$ . Very small amounts of a.f. current will go through  $C_1$  to  $C_2$ , also from  $R_1$  through  $R_2$ , and then either  $C_3$  or  $R_3$  to  $C_2$ —or even through the power pack. However, these are not the intended paths for a.f. and more than a very small amount through any of them will interfere with normal operation. Following are the defects that can interrupt this normal flow.

**$C_4$  Open.** A.F. currents normally reach the chassis through  $C_4$ . If  $C_4$  is open, a.f. signals will take the path through  $R_5$  and  $C_5$ . Parts  $R_5$  and  $C_4$  together act as a hum filter to keep

power supply hum out of the following stages. An open in  $C_4$  will destroy the filter action and let hum into the audio amplifier.

A more serious result of an open in  $C_4$  is the "feedback" which occurs because signal voltage is developed across  $C_5$ , and may be sent to other stages in the receiver through the power supply. (The junction of  $R_5$  and  $CH$  is the d.c. supply lead to other stages as shown in Fig. 1.) This unwanted feedback can cause oscillation, usually that low-frequency "put-put-put" known as "motorboating." A complaint of hum or motorboating isolated to a detector stage of this type should therefore lead

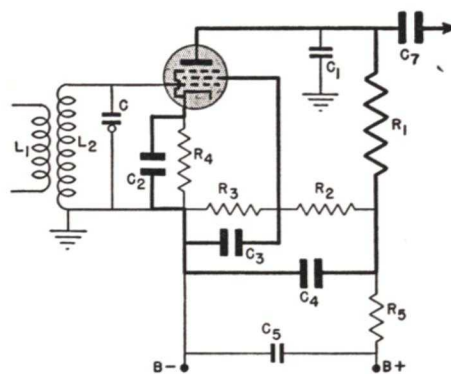

FIG. 3. Here are the a.f. circuits of Fig. 1. Notice that the same parts are sometimes used for both the r.f. and a.f. paths, so a single part may affect more than one path.

you to suspect  $C_4$ . Shunting it with a good condenser will show whether or not your analysis is correct.

**$C_2$  Open.** When cathode by-pass condenser  $C_2$  opens, the i.f. and a.f. impedance of this path from the chassis to the cathode jumps from almost zero up to 10,000 ohms or more, the customary value for  $R_4$  in a pentode detector circuit. Now appreciable amounts both of i.f. and a.f. voltage will be developed across  $R_4$  and act on the grid circuit in opposition to the

signal voltages. Lowered volume is the result of this "degeneration."

Thus the serviceman would be led to suspect an open cathode by-pass condenser if all tubes and voltages checked correctly, but volume coming out of the stage was substantially below normal. Shunting the condenser with a new one would give an immediate jump-up in volume if the defect were an open  $C_2$ .

You can also prove that  $C_2$  is open by connecting across it any type of signal-indicating instrument. If  $C_2$  is good, little signal voltage will develop across it. Appreciable signal voltage across  $C_2$  indicates an open. Here is a case in which you reasoned that an open cathode by-pass was the most likely cause, and confirmed this by making a simple test with a measuring instrument.

**$C_3$  Open.** An open screen grid by-pass condenser permits both an i.f. and a.f. voltage to exist between the screen and ground. The screen no longer acts as a shield between plate and grid and the signal voltages may cause degeneration, reducing the output to a low value. A signal tracer would show either of these voltages and lead you to this condenser.

### SUPPLY CIRCUITS

All d.c. supply voltages come from the power pack, and are shown in Fig. 4. Therefore, there can be no d.c. voltage in the detector circuit exceeding the voltage between point  $\theta$  and the chassis, under either normal or defective conditions. Furthermore, the sum of voltages in any d.c. supply path must add up to this voltage between point  $\theta$  and the chassis. Thus, the voltage drops across  $R_5$ ,  $R_1$ , the tube and  $R_4$  must add up to this supply voltage value.

Two resistors,  $R_2$  and  $R_3$ , act as a

voltage divider which supplies the correct voltage to the screen grid electrode.  $R_2$  alone could do this if of the correct ohmic value, but the addition of  $R_3$  completes a divider circuit which maintains a much more constant voltage under different currents than a single series resistor. Since  $R_3$  is much smaller in value than the screen grid-cathode path of the tube plus  $R_4$ , which are in shunt with  $R_3$ , variations in tube resistance make little difference in the total resistance of the circuit.

With this general picture of the plate and screen grid supply circuits, we can consider a few defects which affect the distribution of voltages in the circuit.

**$R_3$  Open.** Both  $R_3$  and the screen grid-cathode path of the tube in Fig. 4 normally draw current through  $R_2$ . If  $R_3$  opens, only screen grid current will flow through  $R_2$ . As a result, the voltage drop across  $R_2$  will be less and the screen grid will get a higher voltage than before. A high screen grid voltage makes the tube act more like an amplifier than a detector, resulting in weak and possibly distorted reception.

Suppose you were servicing a receiver when the complaint was weak reception. You tested the tubes, analyzed the chassis for surface defects, checked those parts suggested by an over-all effect-to-cause reasoning and failed to isolate the defect. A stage isolating procedure leads you to this detector stage. Several defects here could cause weak reception; an open in  $C_2$ , as previously considered; an open  $R_3$ , and other defects which we can temporarily ignore. You could check both  $C_2$  and  $R_3$ , but analysis may lead you to the defect directly. If distortion is present with the low volume we can forget  $C_2$  and concentrate on  $R_3$ , for an open here may produce distortion while the degeneration caused by an open  $C_2$  actually improves the tone quality. ex-

cept where stray capacity results in a predominance of higher audio frequencies. This technique of considering all symptoms helps you to go directly to the defect.

If  $R_3$  is suspected, a voltmeter test of the screen grid voltage or an ohmmeter check from screen grid to chassis would locate the defect definitely.

**$R_1$ ,  $R_2$  or  $R_4$  Open.** If any one of these resistors in the circuit of Fig. 4 opens, the receiver will be dead because one of the electrode supply circuits will be open. If you were using a signal tracer to isolate the defective stage, you would find r.f. signal voltage across  $C$  but very little (if any) a.f. voltage in the plate circuit. A complete absence of plate or screen voltage should immediately suggest itself.

If  $R_1$  is open, d.c. voltage measurements would indicate that there is no plate-to-chassis voltage but approximately normal voltage between point 5 and the chassis. With  $R_2$  open, there would be no screen grid voltage.

The voltmeter range used in checking from cathode to chassis for an open  $R_4$  will determine the actual reading. Should  $R_4$  be open, then the meter resistance will replace that of  $R_4$ . If a high-voltage range is used first (as it should for meter safety), then it is possible for the meter resistance to be high compared to the sum of  $R_1$  and the tube resistance which are in series with it. Hence, the voltage may be much higher than normal. However, if the meter has low sensitivity, or a low-voltage range is used the voltage may be about normal. The clue here will be the fact that the receiver comes to life as evidenced by noises or signals when the meter replaces the resistor.

**$C_1$ ,  $C_2$ ,  $C_3$  or  $C_4$  Shorted.** A short in  $C_1$ ,  $C_3$ , or  $C_4$  will remove d.c. voltage and kill the stage just the same as an open in  $R_1$ ,  $R_2$ , or  $R_4$ . Notice that

these condensers would furnish unwanted d.c. paths if shorted. Effect-to-cause reasoning cannot tell us whether the trouble is a shorted condenser, an open resistor, or both. A visual inspection might show a charred and blistered resistor, and this would be a strong indication that the condenser at the low-voltage end of the resistor was shorted, allowing excess current to flow through the resistor. Ordinarily, however, with a dead stage, there will be no visible indication, so the serviceman would make a few simple tests with a voltmeter to find whether the d.c. voltages were missing, and if so, which resistor or condenser was the cause.

A glance at the diagram shows that a break-down in  $C_1$  removes plate volt-

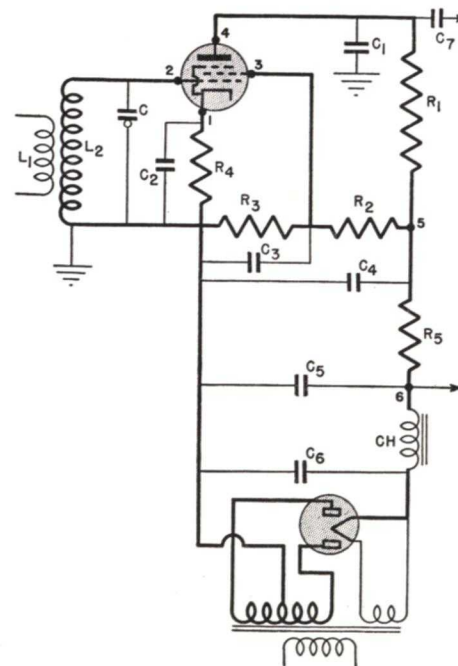

FIG. 4. The power circuits are d.c. paths for supply voltages. An open or short circuit will affect these paths and thus alter one or more of the operating voltages. This circuit is also taken from Fig. 1.

age by grounding the plate, while a short in  $C_3$  will remove voltage from the screen. A shorted  $C_4$  will remove voltage from both plate and screen. Hence, a measurement for these two voltages will determine which condenser or resistor should be suspected.

Should  $C_2$  become shorted, no voltage drop will occur across  $R_4$  and there will be no  $C$  bias. The removal of bias by a shorted  $C_2$  would not kill signal passage through the stage, but detection would be imperfect and the reproduction would be weak and distorted. Effect-to-cause reasoning would lead you to check all the operating voltages in the stage, if weak volume and distortion were the complaint. If normal  $C$  bias voltage did not show up, you would check for continuity from grid to ground, and check the resistance from cathode to ground. A short in  $C_2$  would show up on this test.

## CONTROL CIRCUITS

**A.V.C. Circuit.** Let us consider another kind of circuit, the a.v.c. circuit, to see what kind of help in running down defects we can get from a study of a circuit action.

In Fig. 5, the i.f. signal voltage developed across final i.f. trimmer  $C_4$  is applied between the plate and cathode of the diode  $VT_2$ , reaching the cathode through  $C_1$ . Rectified current flows from the cathode to the plate of the diode, then through  $L_4$ ,  $R_1$  and  $R_2$  back to the cathode. Combination  $C_1$ - $R_1$ - $C_2$  acts as a high-frequency filter which allows only a.f. signals and direct current to flow through volume control  $R_2$ . The a.f. signal is then forwarded to the input of the first a.f. amplifier stage through d.c. blocking condenser  $C_3$ .

The voltage across  $R_2$  will have both d.c. and a.f. components, hence both these voltages will be applied to any

circuits which are connected between point 1 on  $R_2$  and ground.

One a.v.c. circuit which is connected between these points traces from point 1 through  $R_3$ ,  $R_4$  and  $L_2$  to the grid of i.f. amplifier tube  $VT_1$  and from this tube cathode through  $R_5$  to ground and thus back to  $R_2$ . Therefore, the d.c. voltage across  $R_2$  is applied between the grid and cathode of this tube. Condenser  $C_5$  and resistor  $R_3$  act as an a.f. filter, so only d.c. reaches the i.f. tube grid. Any a.f. voltage which is developed across  $C_5$  is further reduced by a similar a.v.c. filter made up of  $R_4$  and  $C_6$ .

In addition, we have a delaying action in these filters whenever any sudden changes in d.c. voltage occur. All this is basic a.v.c. action which you studied earlier in your Course.

Now let us see how certain actions of a receiver suggest an a.v.c. defect, and also see how the effects suggest what to suspect in the a.v.c. circuit.

**$C_5$ ,  $C_6$  or  $C_7$  Shorted.** The symptoms which indicate the absence of a.v.c. are a great difference in volume when tuning from local to distant stations, with overloading on strong signals. Should condenser  $C_6$  or  $C_7$  short, the a.v.c. voltage would be removed from one of the i.f. amplifier tubes and would be reduced on the other, causing similar symptoms. Such marked unevenness in volume between

stations should lead you immediately to check the a.v.c. filter condensers for shorts.

**$C_6$  Open.** If condenser  $C_6$  opens, weak reception will be the symptom because the high resistance of  $R_4$  has, in effect, been added to the path from the tuned circuit to the cathode. A good part of the i.f. signal voltage will be lost across  $R_4$  instead of being applied to the tube. The resistance will also isolate the grid-cathode capacity from across  $C_3$  which will detune the resonant circuit  $L_2$ - $C_3$ , further reducing sensitivity.

This is not a common trouble. However, if the low sensitivity has been isolated to an a.v.c.-controlled stage, consider cathode and a.v.c. condensers after eliminating tubes and alignment. Shunting a good condenser across the suspected one will show whether the original is open.

**$C_5$  Open.** If  $C_5$  is open, the sensitivity of the receiver will not be affected but the time constant of the a.v.c. system will be greatly shortened, that is, the a.v.c. voltage will respond to very quick changes in signal volume such as bursts of static or noise. Such sudden noises may make the receiver go dead for an instant or two. These effects might not be noticed either by the customer or the serviceman, so failure of this part might not be suspected.

## Isolating the Defective Circuit and Part

The foregoing section has furnished you with a number of practical examples of finding a defective part in an isolated stage by reasoning from the symptoms and a knowledge of circuit action in the stage. This method of finding the defect, so that the receiver can be restored to operation has been described first because whenever possible it should be used first in order to "cash in" on the very great savings in time and labor it can afford. As pointed out in case after case, analysis will clearly indicate a certain part as causing a failure, and a simple test or two will then be all that is necessary to confirm the analysis and fix the blame for the trouble exactly where it belongs.

However, when effect-to-cause reasoning does not immediately uncover the seat of the trouble, the professional serviceman needs a systematic testing procedure which will allow him without fail to find the defective part. Standard testing procedures are described in this section, and later in the lesson you will learn how to apply your testing equipment to finding the majority of defects that will occur in each of the main types of receivers now on the market. You will surely be impressed with the fact that while proper testing will in time run down any type of defect, effect-to-cause reasoning may be used at any point in the procedure as a short cut, avoiding the expenditure of a great deal of time and labor.

### SIGNAL-TRACER METHODS

Signal-tracing consists in putting a signal into the input of a receiver, and seeing how far it gets and what happens to it on the way. Since we can, with

signal-tracing equipment, test the condition of the signal in any separate circuit within a stage, this instrument provides a quick method of isolating trouble to an individual circuit.

As an example, consider Fig. 5. Suppose we have a case of weak reception and that we find the test signal behaving normally until we reach the i.f. amplifier grid where the signal voltage drops to a low value. Several parts in the stage may cause this low signal voltage. Condenser  $C_3$  may be out of alignment. The i.f. transformer may have shorted turns or a bad connection. Condenser  $C_6$  may be open.

With the testing probe on the grid terminal, you could readjust  $C_3$  to see if the volume could be brought back up by resonating  $L_2$ - $C_3$ . If you get a

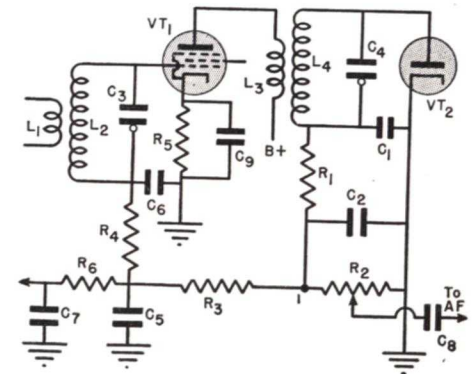

FIG. 5. A typical a.v.c. circuit.

peak reading but the output is still far below normal,  $C_6$  is the most likely suspect. The signal tracer can be used to check this analysis by trying for signal voltage across  $C_6$ . Of course, if the condenser is normal, almost no voltage will be found across it.

Consider a case of weak reception in the circuit of Fig. 1. The signal tracer shows normal i.f. voltage in the grid

circuit, but only a very weak audio signal comes out in the plate circuit.

This could be caused by low d.c. plate voltage, but other troubles must be considered. An open in condenser  $C_3$  or in condenser  $C_2$  could cause the same trouble. Checks across them with a signal tracer would isolate the defective one, as you would find a signal voltage across the defective part.

Signal tracing requires that you have some idea of how strong the signal

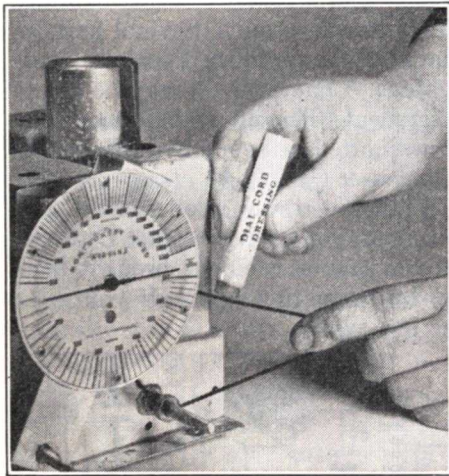

Courtesy General Cement Mfg. Co.

Sometimes a mechanical trouble, like a slipping dial cord occurs. This condition may cause the dial pointer to indicate incorrectly or may even prevent tuning, depending on the mechanism. Rosin can be used, or a handy stick-type dial cord dressing can be used as shown here. The material rubs off on the cord, forming a surface having more friction so the cord does not slip as readily.

should be at each point in the receiver, under normal conditions. Naturally, if you follow the signal from the input through the various amplifier stages, there should be a gain of voltage in each stage. However, converter tubes such as the first or second detector may not show an actual increase in voltage over the preceding stage. Many set manufacturers now furnish stage gain data, and experience will of course also

help you to know when signal voltage readings are normal.

Since defects in power supply circuits usually result in removing the d.c. voltages on the tube electrodes, the stage is likely to be dead, and signal tracing will not be found quite as useful in the case of a dead stage as with weak or distorted reception. Where electrode d.c. voltages are involved, the d.c. voltmeter and ohmmeter are most useful in running down the defective part in the stage. The general methods of using these instruments for maximum results will now be described.

### ELECTRODE VOLTAGE TESTS

Voltmeter tests in a defective stage naturally begin with a check of plate voltage, followed by measurements of the other electrode voltages in turn. The receiver is on but not usually tuned to a station. Abnormal voltage or lack of voltage will lead you to suspect some part or series of parts as being defective, and further tests will then isolate that part. The parts to be tested will of course be those in the supply circuit where voltages are missing or abnormal.

As an example, suppose we find no plate voltage on the tube of Fig. 4. Assuming we have isolated the trouble to this stage, we know that the power supply is working as other stages are operating, so the defect must be somewhere in the plate circuit of this stage only. Inspection of the diagram shows that the plate circuit consists of  $R_5$ ,  $R_1$ ,  $C_4$ , and  $C_1$ , and that defects in these parts could interrupt the plate voltage.

We could begin to run the part down with the voltmeter by checking the voltage at point 5. If voltage existed here, the most likely candidates are an open in  $R_1$  or a short in  $C_1$ . A short in

$C_1$  will make  $R_1$  take the full voltage from point 5 to chassis. The meter will show whether or not the voltage across  $R_1$  is the same as from point 5 to chassis. If it is, count on a shorted  $C_1$ .

If the voltage across  $R_1$  is less than from point 5 to the chassis, however, and the receiver shows signs of coming to life when the voltmeter probes are across the resistor, it means that  $R_1$  is open. You can easily see that in making the measurement you substituted the meter for the resistor  $R_1$ , so that plate voltage reached the tube through the meter resistance.

Making voltage measurements has the advantage of checking the receiver while all parts are under normal voltage stress. This is valuable because many troubles, particularly shorts in condensers, may appear only when full voltage is applied.

The serviceman has a wide choice of meters for use in voltage tests, but the meter should have a sensitivity of at least 1000 ohms-per-volt, and should have several ranges. The d.c. vacuum tube voltmeter can be used to measure all voltages with respect to chassis and does not usually load the circuit as does the ordinary voltmeter. However, where both ends of the part are above chassis potential, the vacuum tube voltmeter must usually be applied by measuring the voltage to chassis at each end of the part, and then taking the difference between the two. For example, the voltage between point 5 of Fig. 4 and chassis may be 200 volts, while that between the plate and chassis may be 75 volts. The difference, 200 — 75, or 125 volts, is the drop across  $R_1$ .

Other precautions well worth observing are to always start on the highest range of a multi-range meter in testing an unknown voltage, and to disconnect the meter from the voltage

under test when changing ranges. Failure to follow these rules is likely to result in a burned-out meter or in arcing at the contacts of the range-changing switch.

The question of what should be considered normal readings at the tube electrodes will depend on the type of meter being used. The values shown in service manuals are generally based on measurements with a 1000 ohms-per-volt meter. If you use a more sensitive meter or a vacuum tube voltmeter, you would expect to get higher values in any high-resistance circuits. Remember, too, that voltages in radio circuits are in most cases dependent on resistor values, and that these can vary as much as 20% from the stated value.

If these limitations are kept in mind, and as you gain experience in making voltmeter readings, you will find that the d.c. voltmeter can be a fundamental part of your servicing technique. Later in this lesson, you will learn exactly how the voltmeter is applied to uncover the defects you will actually encounter in servicing each of the main types of receivers now on the market.

### ELECTRODE CONTINUITY TESTS

After signal tracing and electrode voltage tests, continuity tests with an ohmmeter must be added to make your general servicing technique complete. Ohmmeter measurements must always be made with the receiver turned off and preferably disconnected entirely from any source of power. If you fail to turn off the set, voltages across the parts being tested will not only give erroneous readings but will likely damage the meter. And after turning the receiver off, wait for a minute or so for the filter condensers to discharge or else short-circuit them with a screwdriver or test lead to be sure they are

not storing voltage.

The real value of continuity tests in a servicing procedure is that by testing across the two ends of a given circuit, you get a quick check of every part included in that circuit. This applies, of course, to every circuit having d.c. continuity. By testing for continuity from each positive electrode of the tube to the highest positive point in the power pack, and from each negative electrode to the highest negative point in the power pack, you can quickly discover whether any of the d.c. supply lines is out of order. Checking all of these supply paths will cover most of the parts of a stage.

The location of positive and negative reference points will vary in different types of receivers, and will be covered in detail in the practical examples given later on in the lesson.

Of course, the symptoms of the receiver may give you a clue as to which of the paths to check first. For example, suppose we find the symptoms of no a.v.c. action in the circuit shown in Fig. 5. This could be caused by a shorted a.v.c. filter condenser, and an ohmmeter check from the grid of the i.f. tube to ground will quickly reveal this condition. This path should normally show a d.c. resistance equal to the values of  $R_2$ ,  $R_3$ , and  $R_4$ , and a shorted condenser will read very much less than this, in the case of  $C_6$ . A short in  $C_5$  would give a reading equal to  $R_4$ . A short in  $C_7$ , however, would not stand out clearly because  $R_4$  plus  $R_6$  is comparable in value to  $R_4$  plus  $R_3$  plus  $R_2$ . The measurement for  $C_7$  would have to be made from the grid of the first i.f. tube to chassis.

Ohmmeter tests will not reveal open condensers. Suspicion will fall on such condensers from the symptoms they set up in receiver operation. Many of the symptoms of open condensers have al-

ready been described, and other cases will be taken up later in the lesson. In each case the quickest and most practical test, unless signal-tracing equipment is at hand, is shunt a suspected condenser with a good one.

Many times you will find it most efficient to combine ohmmeter and voltmeter tests. For instance, take the

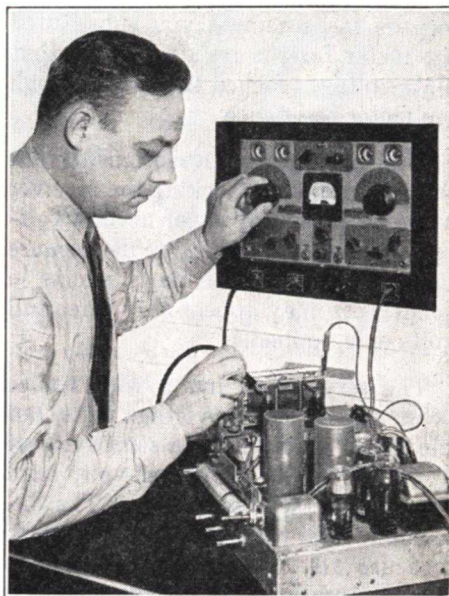

If the preliminary surface defect check and effect-to-cause reasoning do not lead right to the trouble, some means of section and stage isolation is used. If available, a signal tracer can be used as shown here. This instrument is particularly helpful in some of the more difficult jobs, such as weak or intermittent reception complaints.

case in the section on voltage tests where no voltage was found on the plate of the tube in Fig. 4. Two parts are suspected,  $C_1$  and  $R_1$ , and an ohmmeter test of each of these parts will show whether  $C_1$  is shorted or  $R_1$  is open.

Some servicemen eliminate the voltmeter altogether and depend on the ohmmeter alone, using the d.c. supply

continuities from the tube to the power pack to cover opens, and checking across from positive to negative to find shorts. These tests will be covered in detail later on, but you can easily see that the serviceman has somewhat of a choice in his use of instruments. The voltmeter may be used to find trouble and the ohmmeter to check parts, or instead of using both instruments, either can be used alone. As you become highly experienced, you may find that one or the other works quicker for you. But in the meantime, it is necessary to understand thoroughly the use of both, since the serviceman who can use either instrument as the need arises will never be at a loss for means of finding the defective part in a receiver.

**Practical Pointers.** D.C. resistance values of coils are usually given on circuit diagrams, to help in continuity measurements. A few shorted turns in a coil have little effect on the total resistance of the coil, even though the short may cause the receiver to operate improperly. In power transformer windings, a few shorted turns may cause considerable heating and eventually ruin the transformer. In r.f. tuning coils, a few shorted turns can greatly reduce the inductance and the Q factor.

The fact that a measured value of coil resistance differs from that given on the diagram does not necessarily mean that the coil is defective. Normal variations in coil resistance of normal inaccuracies in the ohmmeter itself may result in different readings. Only when the ohmmeter reading is considerably different from the specified value can it be considered as pointing to a defective coil.

When measuring center-tapped coils of iron-core a.f. or power transformers, do not expect the resistance to be the same for both halves of the winding.

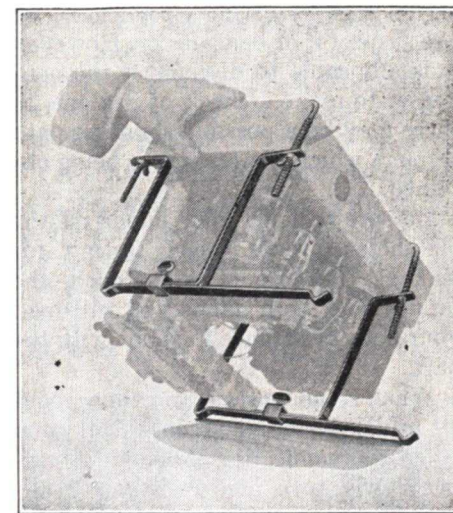

Courtesy General Cement Mfg. Co.

Radio receivers must be turned on edge or upside down to be worked on. They may be so made that they do not stand on edge readily, and the presence of an elaborate dial mechanism and the tubes may prevent turning the chassis upside down. Servicemen then must block up the chassis on old parts or use a manufactured support. The brackets shown here are quickly attachable and serve to protect the delicate parts on top the set as well as hold the set in an easy-to-work-on position.

An electrical center tap means equal turns on each half, but in the usual layer-wound construction of these windings the outer half of the winding will have a larger diameter and hence, more wire and more resistance.

When we test condensers with an ohmmeter, we must remember that it will show continuity only if the resistance being measured is within the range of the particular ohmmeter being used. A good paper or mica condenser should have a leakage resistance above 50 megohms-per-microfarad. Hence, practically any ordinary paper condenser found in a radio should have a leakage resistance above this value which is far beyond reach of the average ohmmeter. Therefore, when a steady reading is obtained



across a paper or mica condenser, we can suspect it of being leaky. However, it is advisable to disconnect the condenser to make a check of it alone, as there may be a possible shunting path through which the reading is being obtained.

Be sure to keep your hands off the ohmmeter probes when testing for leakage, because if you touch the probes with both hands you will read your body resistance in shunt with the part.

When a condenser larger than about .01 mfd. is tested, the pointer will jump when the connection is made, returning slowly to a high-resistance reading. Be sure to wait for the pointer to stop moving. This will take several seconds with large condensers, or with any circuit in which high-capacity condensers are connected.

Electrolytic filter condensers have much lower leakage resistance than other types. Two values will be found, depending on the polarity of the test

probes. The higher value is the correct one.

Whenever there is the least possibility of doubt regarding your interpretation of ohmmeter tests for condensers, always disconnect one condenser lead and try a new condenser of approximately the same capacity in the position of the old one. The working voltage of the test condenser must be as high or higher than the old one. This will give you a positive test and will often save considerable time in trying to interpret confusing ohmmeter readings.

If the receiver has just been turned off, wait for the tubes to cool before making ohmmeter tests. Otherwise, you may get readings through the tube itself if the positive ohmmeter probe is connected to some element while the negative probe is connected to the cathode. Emission continues until the cathode cools, so the ohmmeter battery causes a current flow through the tube.

## Examples of Parts Isolating Tests For Power Line Receivers

Now that we understand the basic procedures for using the voltmeter, ohmmeter, and signal tracer, we can learn the actual tests that form a major part of the day-in, day-out work on any efficient service bench. The examples to be given will cover all of the usually found defects that occur in each of the standard types of power-line receivers:

1. A.C. receivers using power transformers (also vibrator-rectifier systems).

2. A.C. receivers without transformers.

3. Universal a.c.-d.c. receivers.

We repeat, the tests to be described, if thoroughly studied and understood, will give you the ability to solve smoothly and swiftly the major part of the receiver troubles that you will meet in professional servicing. Remember that we have narrowed the trouble to one stage, and that our problem in each case is to find the defective circuit and part in that stage

that is actually the seat of the trouble. The replacement of the defective part is the end toward which all testing methods should be directed.

Further, remember the general rules we will now develop by examples can be applied to all types of receivers—even those using other power supplies as long as the circuit is basically similar.

### A.C. RECEIVER WITH POWER TRANSFORMER

The circuit diagram in Fig. 6 shows the first a.f. amplifier stage and the power pack of a typical a.c. receiver employing a power transformer. The other stages in this receiver have been omitted from the diagram for the essential facts regarding the isolation of the defective part can be more easily realized if we do not complicate our circuit.

**Electrode Continuity Tests.** In all a.c. receivers having power transformers and all receivers using both a vibrator and a rectifier tube, the following basic continuity rules apply:

1. All positive electrodes, such as plates and screen grids, will have a conductive path to the *cathode of the rectifier tube*, which is the most positive reference terminal.

2. All negative electrodes, such as control grids, suppressor grids and cathodes, will have a conductive path to the *center tap of the high-voltage secondary*, which is the most negative point in the receiver. Since the plates of the rectifier tube connect to this center tap through the high-voltage secondary, and since these plates are easier to locate than this transformer terminal, it is common practice to use one of the plates of the rectifier tube as a reference point when checking the continuity of the negative electrodes. Furthermore, if the trouble has been

localized to a stage and we can be sure that nothing is the matter with the power pack through previous tests, the set chassis can be used as the negative reference point.

To make continuity tests in the first a.f. amplifier stage shown in Fig. 6, you could place one ohmmeter probe on a filament terminal of the type 80 rectifier tube (the filament here serves also as the cathode), and place the other probe on the plate of the type 75 tube.

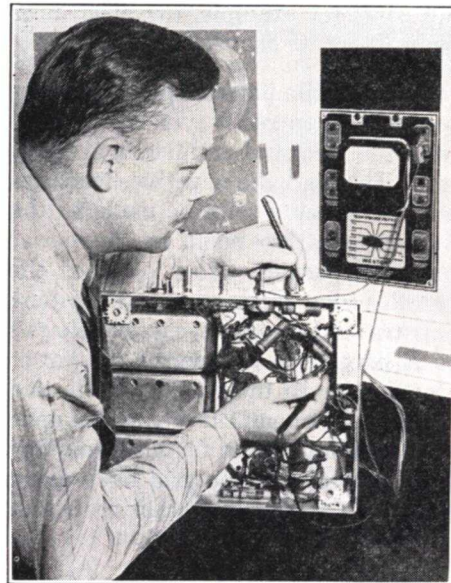

The final step is one of localizing the defective circuit and part. The service multimeter is now used. Voltage and resistance readings, properly interpreted, will lead right to the trouble whenever the defect is of such a nature that any supply circuit is affected.

The ohmmeter should read the total resistance of this circuit which is the sum of 75,000 ohms ( $R_{22}$ ) plus 50,000 ohms ( $R_{23}$ ) plus field coil  $CH$ , another 2000 ohms, or a total of about 127,000 ohms. Any value from about 100,000 ohms to 150,000 ohms should be considered correct.

If the value is radically different, there is a defect of some kind in the



from the socket, with the power on, and measure the drop across  $R_{22}$  and  $R_{23}$ . Naturally, unless the condensers are leaky, there is no path for current to be drawn through the resistors, and there should be no voltage drop across them, with the tube out of the socket. A drop through both resistors points to leakage in  $C_{27}$  or  $C_{32}$ , while a voltage drop across  $R_{23}$  alone points to  $C_{41}$ .

A d.c. vacuum tube voltmeter can be used for this test very effectively by making the measurements to chassis. With the tube out and no leakage, points 1, 3, and 4 should all have the same potential to chassis. If it drops at 3 but no further drop at 1, then  $C_{41}$  is leaky; if it drops from 4 to 3 to 1, then leakage in  $C_{27}$  or  $C_{32}$  is indicated. Only the vacuum tube voltmeter can be used to read the voltages to chassis on this test, since any other meter draws current through the resistors so that drops will occur anyway, making it hard to tell if leakage exists.

The second important electrode voltage in this stage, the grid bias voltage, can be tested with a voltmeter if the resistance of the meter is carefully accounted for. The bias voltage is developed between cathode and ground by the passage of plate current through resistor  $R_{20}$ . If you put a 1000 ohms-per-volt meter, using the 3-volt range; across cathode and ground, you are actually connecting 3000 ohms in shunt with  $R_{20}$ . This reduces the bias resistance to 1200 ohms, and the voltage will go down accordingly. Plate current will increase, but not enough to bring the bias up to normal. If you remember that the voltage you get in making this measurement is lower than the voltage when the meter is removed, the measurement is a valuable indication that some bias voltage exists. A high-sensitivity meter or a vacuum tube voltmeter will of course read close

to the actual bias voltage.

The bias voltage should naturally exist between grid and cathode, but direct measurement across these elements with a low-resistance meter is even more misleading than across the bias resistor. The meter would join with  $R_{21}$  as a voltage divider across  $R_{20}$ , and almost the entire drop would be across  $R_{21}$ , which is several hundred times the value of the meter resistance. This measurement can be made only with a very high-resistance meter.

If you have found approximately normal bias voltage across  $R_{20}$ , you can make sure that it reaches the grid by removing the tube (to prevent false readings through it) and measuring the voltage from plate to grid. If you get a reading here, it proves that the grid circuit has continuity to chassis as the voltmeter is actually measuring the plate-chassis voltage through the grid resistance. Should the circuit be open, there would be no complete path for the meter current so it would not read. The value of the voltage on this reading is unimportant and highly variable with meter sensitivity and the plate and grid resistors. The test is for the existence of any voltage at all, to prove that grid and chassis are connected.

A last important voltage measurement in the stage of Fig. 6 would be across resistor  $R_{21}$ . Normally, there is no d.c. voltage drop across this resistor because in a receiver voltage amplifier, under normal conditions, there is no d.c. current flow through the resistor. A voltage drop across this resistor, indicating current flow, means that  $C_{26}$  is leaky or the tube is gassy. To eliminate the tube from the test, remove the top cap from the grid. If this stops the current flow, the tube is guilty, but if not, it is  $C_{26}$ .

The foregoing examples show clearly

that it is a combination of logical reasoning with simple measurements that forms the real backbone of professional servicing. If you study your theory to get the real "feel" of circuit action and learn the simple, straightforward testing procedures described in these lessons, these two will go to work together for you and you will honestly go places in radio.

### A.C. RECEIVER WITHOUT POWER TRANSFORMER

Another of the major types of receiver you will encounter as a serviceman uses the voltage-doubler circuit of Fig. 7, which includes one i.f. stage with the power pack. The electrode continuity and electrode voltage tests that serve to run down a defective part in this stage will now be described.

**Electrode Continuity Tests.** Considering the power pack first, note that  $C_{20}$ -CH- $C_{21}$  make up the power pack filter system. Point 3, the cathode of rectifier tube B, is the highest positive terminal. Point 2, which is conductive to the plate of rectifier tube A, is the most negative terminal. We thus return to the same basic reference terminals in the power pack as in an a.c. receiver having a power transformer.

To locate the correct cathode terminal for use as the highest positive reference point, trace visually a lead from the choke coil to the rectifier cathode. (This lead may go to an electrolytic condenser terminal first.) Presuming the power supply is normal, as proved by the fact that a part of the receiver is functioning, we do not have to go to this cathode. We can use the electrolytic condenser positive terminal 3 or 4 if more convenient.

The negative reference point is B — and there are a number of points connecting to it which are easy to locate by visual inspection. Among them are

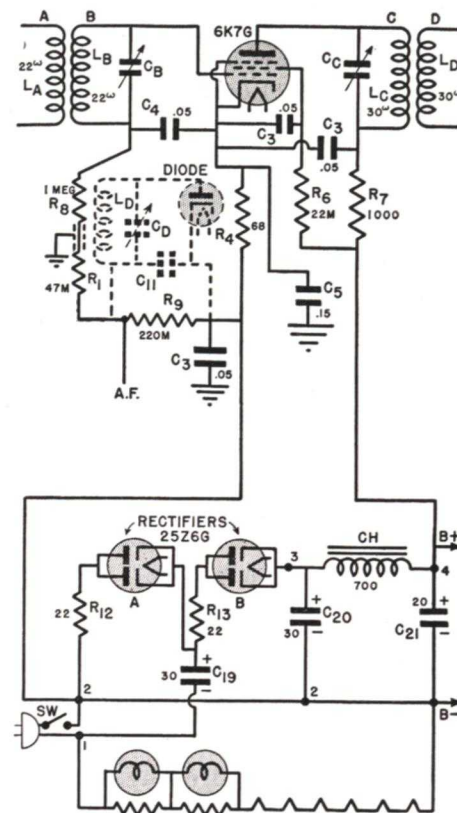

FIG. 7. Power supply and i.f. stage used in the Zenith 5719 receiver. The diode detector circuit has been redrawn in dotted lines to show its relationship to the grid return circuit of this i.f. stage. Coil  $L_D$  feeds this detector. Notice the manufacturer identifies parts having the same electrical size with the same code number. Thus, there are three condensers marked  $C_3$ , all having .05 mfd. capacity.

the set side of the ON-OFF switch SW and the negative leads of  $C_{20}$  or  $C_{21}$ . The switch terminals must be identified unless you turn on the switch, in which case either terminal can be used. The cathode of the diode detector tube (shown by dotted lines) connects to B —. Also, the 6K7G cathode can be used, if you are sure that the 68-ohm resistor  $R_4$  is in good condition.

Remember, the set *MUST* be disconnected from the power line when

making continuity tests, to avoid shocks and possible damage to your ohmmeter. There is no necessity of using the plate of rectifier tube *A* for this reference point.

Continuity tests for screen grid and plate supply circuits are made by using the positive reference point (3 or 4) in the power pack as the common reference terminal for one probe of the ohmmeter and connecting the other ohmmeter probe to the plate and screen grid terminals in turn.

Similarly, point 2 or some part connected to it directly is used as a reference point for continuity tests of the cathode and control grid supply circuits. Notice that the *chassis is not a part of this circuit*. Don't use the chassis as a reference point in a transformerless power pack set (or an a.c.-d.c. set) unless the diagram shows that it is part of the circuit.

Careful analysis of continuity test readings is required to locate shorts in this stage. For example, in the plate supply circuit we have  $L_C$ ,  $R_7$  and  $CH$  in series. A direct short across either  $CH$  or  $R_7$  will be indicated as lower resistance than normal for this circuit (considerably less than 1700 ohms), but a short in  $L_C$  would not be revealed by the initial continuity test because the resistance of this coil is quite low in comparison to the rest of the circuits. In other words, you cannot clear coil  $L_C$  of suspicion of being shorted by making a resistance measurement between the plate and terminal 3; you must measure directly across the coil, on a low ohmmeter range, to make 30 ohms stand out. Should you locate a short across  $L_C$ , you would be required to unsolder one lead of  $C_C$  to prove that the trimmer condenser is not defective. Also remember that you must allow some tolerance from the values shown in the manual, so that the re-

sistance change of a few shorted turns could not be detected by an ohmmeter test.

Shorted turns would change the inductance of the coil greatly, however, and make it difficult or impossible to "peak" the transformer during alignment as you will learn later. Observation of the action of the trimmer condenser or the use of signal-tracing equipment will localize this defect.

Shorts in screen grid and plate by-pass condensers are revealed by ohmmeter tests. However, notice that the short circuit will be to the  $6K7G$  cathode, *not* to the chassis. You could use either the cathode of the i.f. amplifier tube or point 2 as a reference point and move the other ohmmeter probe to the  $6K7G$  plate to check for a short in the plate by-pass  $C_3$ , then to the screen grid for a short in the screen grid by-pass. (This is also marked  $C_3$  on the diagram. Many manufacturers number capacities having the same value with the same number on diagrams. You must study the circuit to see which is meant.)

Sometimes a serviceman will check for continuity and will find an open, such as an open  $R_7$ . Replacing this resistor, he finds the set still does not function and the replacement smokes and overheats. Plate bypass  $C_3$  is probably shorted, which caused the original burnout of  $R_7$ . It is well to check for such possible shorts whenever an open circuit is found, before replacing the open part. Combination troubles like this are quite common.

**Voltage Measurements.** Electrode voltage measurements on this receiver are made in the same way as on an a.c. receiver with power transformer. The only difference is that the measurements are not made from positive points to chassis, *because the chassis in this set is not in the d.c. supply cir-*

*cuit*. Therefore, the measurements must be made between positive points and the cathode of the i.f. tube, or to point 2 in the power pack.

**WARNING.** If the voltage-doubler circuit is like Fig. 8 instead of Fig. 7, then the switch will not connect to *B* — nor can the negative lead of filter condenser  $C_1$  be used as a reference point. You will have to make use of the cathode of the tube in the defective stage or find the negative side of filter condensers  $C_2$  or  $C_3$ .

### UNIVERSAL A.C.-D.C. RECEIVER

**Electrode Continuity Tests.** In a.c.-d.c. receivers, the first job is always to find the reference points for continuity tests by a study of the diagram. For instance, a look at the second detector-1st a.f. stage of a typical a.c.-d.c. set shown in Fig. 9, will show that the highest positive reference point is the cathode of the rectifier tube. However, no d.c. continuity can be traced to the plate of the rectifier

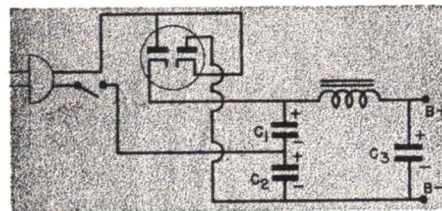

FIG. 8. This full-wave voltage doubler does not have the same reference points as the half-wave type shown in Fig. 7.

tube from *B* — if the filament circuit is broken. The *B* — circuit ends at the set side of the ON-OFF switch, which can therefore be used for all continuity tests to negative electrodes. This use of the ON-OFF switch applies to a great many a.c.-d.c. sets, but it is always necessary to check the position of the switch on the diagram because in some sets it is in the positive side of the power line instead.

The cathode of the  $12SQ7GT$  is seen to connect directly to this negative reference point and the grid connects to it through 15-megohm resistor  $R_6$ .

The detector section of the  $12SQ7GT$  tube of Fig. 9 requires no d.c. supply voltage, but since it does provide an a.v.c. voltage for the grid circuits of other tubes, we can check continuity from the diode plate to the negative

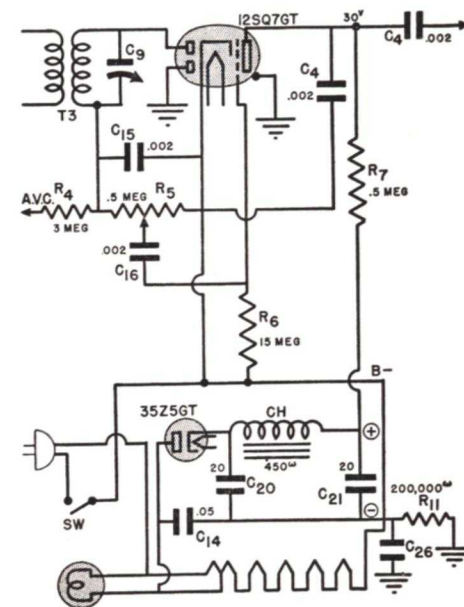

FIG. 9. Power supply and detector-first a.f. stages of the Emerson FC-400 universal a.c.-d.c. receiver.

reference terminal in the power pack, just as we do for negative amplifier tube electrodes. The a.v.c. voltage is developed across volume control potentiometer  $R_5$ , and applied to the grids of the i.f. tubes through resistor  $R_4$ .

**Electrode Voltage Tests.** Just as in the receiver of Fig. 7, it is necessary before making voltage tests to determine whether or not the chassis is in the d.c. supply circuit. In Fig. 9, the chassis is connected to *B* — only

through the high resistance  $R_{11}$ , so the chassis cannot be used for voltage measurements.  $R_{11}$  is provided to discharge  $C_{26}$  when the set is turned off, to reduce the danger of shock.

The 30 volts shown on the diagram as the plate voltage of the triode in Fig. 9 is based on measurement with a 1000 ohms-per-volt meter. It is good to remember that the actual operating voltage is higher and in this case, the difference between measured and actual voltages will be considerable because of the very high resistance of  $R_7$ . If you use a 1000 ohms-per-volt meter, you should of course get a reading not far from 30 volts, but a high ohms-per-volt meter in this plate circuit will give a higher reading.

Grid convection current flowing through grid resistor  $R_6$  of the triode section will produce a self-bias voltage of about 1 volt for the grid. If you measure the voltage between grid and cathode with a 1000 ohms-per-volt voltmeter during electrode voltage tests, however, the reading will be practically zero, since the meter shunts resistor  $R_6$  down to a low value and thus makes the voltage drop across it minutely small. A vacuum tube voltmeter would measure this voltage across  $R_6$  or the continuity of the circuit can be checked with a high-range ohmmeter.

If  $R_6$  opens, you would probably expect a dead receiver on the theory that the grid would then acquire a high enough negative charge to block plate current in the triode section of the tube. Actually, however, it is likely that there would be enough leakage between the grid and cathode terminals of the tube socket (due to dust and moisture) to provide almost normal grid bias.

Hence, instead of a dead set, a more

likely possibility is that with high leakage resistance here, the stage might block at regular intervals with accompanying distortion and hum. An ohmmeter test of  $R_6$  would be the proper procedure here if an ohmmeter with a 15-megohm range is at hand; otherwise, try shunting  $R_6$  with a good resistor having a value around 15 megohms.

When testing the grid circuit for possible defects, condenser  $C_{16}$  should concern us. If  $C_{16}$  becomes leaky, a portion of the d.c. voltage developed across  $R_5$  would be applied across  $R_6$ , producing distortion which becomes more noticeable as volume is increased. As resistor  $R_6$  has a high ohmic value, even a small amount of leakage in  $C_{16}$  will develop an appreciable voltage across  $R_6$ . To check for leakage in  $C_{16}$ , you can unsolder one of its leads and measure its resistance with a high-range ohmmeter, or try another condenser.

Here is a case where a voltage measurement across  $R_6$  would indicate the leakage through  $C_{16}$ . Disconnect the lead to the grid of the tube to eliminate the self-bias normally developed in this resistor. Tune in a station and set volume control at maximum so the maximum a.v.c. voltage across  $R_5$  is applied to  $C_{16}$ , then check for a voltage across  $R_6$ . A high-sensitivity d.c. meter must be used to check this voltage across  $R_6$ .

This is a case where a leaky coupling condenser produces a negative voltage (with respect to B—) across the grid resistor, due to the polarity of the a.v.c. voltage which is acting as the d.c. source. In cases where the coupling condenser connects from the preceding tube plate, the grid end of the following resistor will be made positive.

## Examples of Part-Isolating Tests for Battery and Vibrator Receivers

The basic procedures for these receivers are very similar to those you have just finished studying. Therefore, we can start right in on battery-powered receivers.

### BATTERY RECEIVERS

There are two kinds of battery receivers, those operating entirely from batteries and the combination a.c.-d.c.-battery types. The combination types must be studied both as battery receivers and as a.c.-d.c. receivers. The main difference between combination types and universals is that in the combination types the filaments must get d.c. power, usually from the power supply or the cathode circuit of the output tube, and hence cannot be connected directly to the power line. Here we will limit ourselves to the type operating from batteries only.

What are the differences in the usual battery receiver from those we have already studied? Remember that the methods of using continuity tests and voltage tests which we have learned in this lesson are basic to all types of receivers. Once the fundamental tests are learned, it is only necessary to consider the differences in the different types of receivers in order to figure out the applications of the tests to any type of receiver encountered.

First of all, in battery receivers the filaments are used directly as cathodes. The filaments may be in series or in parallel. In cases where the filaments are in parallel, the chassis will usually be part of the d.c. circuit so it can be used as the negative reference point.

A quick indication of whether the filaments are series or parallel can be had from the relation of the "A" voltage to the rating of the tubes. Natural-

ly, the tube filament voltage ratings must add up to the "A" voltage for series connection, but the "A" voltage is approximately equal to that of a single tube for the parallel connection.

A caution—it is usually not wise to pull out tubes in battery sets with the voltage on. In parallel-connected sets, there may be a series resistor to drop the "A" voltage to the proper value and if a tube is pulled out, the voltage on the remaining tubes may rise enough to damage them.

The leads connecting to the B battery are very convenient continuity reference points in battery sets, and continuity tests will be described below. Voltage measurements can be made between the B— battery lead and any positive point in the set or from chassis if it is in the circuit, and are exactly like those already described earlier in this lesson.

**Electrode Continuity Tests.** Before an ohmmeter is applied to a battery receiver, it is necessary to disconnect all batteries to avoid damage to the meter.

For practical examples of ohmmeter tests, consider the typical battery receiver of Fig. 10. This is the way the diagram appears in service manuals with parts identified only with numbers.

Note that the cathode of the 1C5G1 is connected directly to chassis, as is one terminal of the "A" battery. Since the other side of the filament goes directly to the battery, it is evident that the filaments are in parallel and that each one in the set will be grounded on one side.

The double-pole, single-throw switch SW is typical of battery receivers, as

it will interrupt both "A" and "B" supplies when turned off. This is a necessary arrangement to prevent leakage through electrolytic condenser 13 from ruining the "B" battery if only the filament was turned off. This switch must be closed before making continuity tests from the battery leads after disconnecting the batteries.

In case the battery leads are not marked to show polarity, you must write down the color code before disconnecting the leads from the battery. In the case of battery leads connecting to a plug which fits into a socket on the batteries, you will have to trace the leads into the set or use a voltmeter to find positive and negative terminals of the battery socket, so the corresponding plug pins can be identified, after which the leads can be labeled. A voltmeter will be essential in the case of a receiver having "A," "B" and possibly "C" batteries all in one block and with a plug connector.

Once the polarity of the battery leads is established, continuity checks to the tube electrodes are made in the same way as for the other receivers already discussed.

The isolation of defective parts in the simple circuits of the typical battery receiver is relatively easy. For instance, suppose that part 15 in Fig. 10, an 800-ohm resistor, is open. This is the bias resistor for the output stage but note that the plate and screen currents of all stages go through it. An open in this resistor will remove plate and screen voltages from the whole set, killing all operation. The continuity check from B+ to plate and screen would read correctly, but the test from grid to chassis would indicate an open which would have to be in part 10 or part 15. A check across each with the ohmmeter will quickly find the open.

**Voltage Tests.** This same open re-

sistor could be found with voltage measurements. By any method of stage isolation we would have found the receiver dead and would suspect a lack of voltage on the plate. A measurement from plate to B— would show voltage, but a measurement from plate to chassis would show no voltage. This definitely puts the open be-

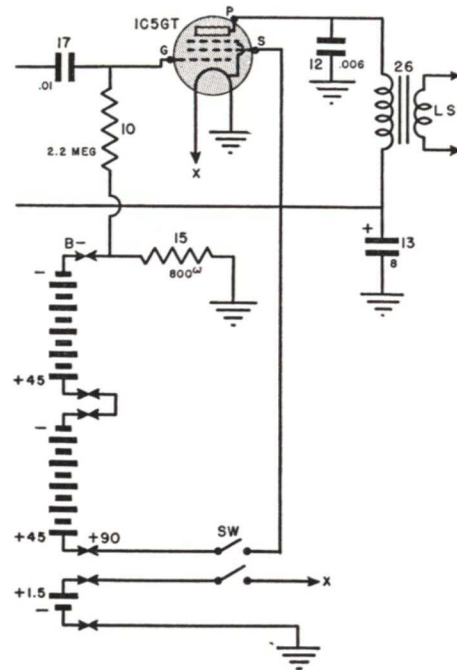

FIG. 10. Output stage of the Stewart-Warner 02-4A battery powered receiver.

tween chassis and B—, and part 15 is the only such connection.

This example shows the importance of using proper reference points, and also shows that the use of more than one reference point is valuable if the circuit diagram is carefully studied.

**Other Defects.** A complaint often found in battery receivers arises from an open in the 8-mfd. electrolytic condenser, part 13. At first thought, it would seem unnecessary to use a large

filter condenser in a battery receiver, with no a.c. hum voltages to filter out. The condenser is not for hum filtering, however, but to provide a path around the "B" battery for r.f., i.f., and a.f. signal currents. With a new battery, this would not be necessary because the resistance of the battery is low but as the battery ages, its resistance will often rise markedly. The signal currents through the battery then develop signal voltages across it which are fed from one stage to another since the "B" battery is common to all stages. This "feedback" is a potent cause of oscillation. With condenser 13 across the battery, such oscillation is eliminated.

Thus, oscillation in a battery receiver should lead you to shunt condenser 13 with a new one. If the trouble stops, replace the condenser.

Opens in condensers 17 and 12 of Fig. 10 would not be revealed by an ohmmeter or voltmeter test but must be found, as previously described, from the operational symptoms of the receiver or with signal-tracing equipment.

## RECEIVER USING SYNCHRONOUS VIBRATOR

Receivers having vibrators followed by full-wave rectifier tubes are handled in exactly the same way as ordinary a.c. receivers with power transformers, once the vibrator circuit is checked and cleared of suspicion.

However, in full-wave synchronous vibrator systems, there is no rectifier tube with cathode and plate terminals to serve as reference points for continuity tests. Furthermore, even after we locate reference terminals in receivers of this type, certain special precautions are necessary to avoid confusing readings. Therefore, let us go through the general procedure involved here for isolating the defective part,

using the typical circuit in Fig. 11 as an example.

**Electrode Continuity Tests.** The diagram shows that the cathode and control grid circuits connect to the chassis. This is typical of synchronous vibrator receivers. Hence, the chassis is the reference terminal for all continuity tests to negative electrodes.

If we trace through the entire plate supply circuit of the 6S7G tube, starting from the plate, we see that there is continuity through parts 47, 46, 2 and 3 to point c, which is the center tap of the secondary of part 66, the power transformer. The center tap c of the high-voltage secondary winding is, therefore, the highest positive terminal in a power pack of this type.

It may not be easy to locate the secondary center tap c, as the transformer may be mounted in a shielded container. This container may even include choke coil 3, condenser 16 and, in some cases, choke coil 2.

Therefore, we may have to find some other point as near the power supply as possible for a positive reference point. The positive terminal of a filter condenser is usually easily found, or you might use the plate or screen grid terminal of the output power tube. Using these output tube terminals as positive reference points—if the output stage is found to have normal voltages—is a very convenient method and can be used in any type of receiver.

When the receiver of Fig. 11 is turned off to make a continuity test, the vibrator arm may be touching contact "B." This grounds one end of the high-voltage secondary, making it impossible to check the positive circuits for shorts to the chassis. This difficulty can be avoided by pulling the vibrator out of the socket. If the vibrator can not be removed but the moving parts are accessible, paper can be put

between the contacts. If the vibrator is sealed up in a metal housing, it is best to break the circuit at point *c* and use the lead so disconnected as the reference point.

Suppose that condenser 27 in Fig. 11 becomes leaky, drawing a high current through resistor 46 and burning it out. Ordinarily, a continuity test from the plate of the tube to the highest positive point would immediately show an open, but if vibrator contact *A* or *B* is closed, there will be a d.c. circuit through 47 and through shorted condenser 27 to the chassis, through contact *B* and the secondary winding to point *c*. This looks as though the plate supply circuit is unbroken. If the vibrator is removed, the open will be immediately apparent.

A continuity check to the plate of the 6S7G would normally read about 400,000 ohms, the total ohmic value of parts 47 and 46. If this value is found, then we can check for shorts to the chassis. These might be in parts 12, 27, 11, or 16. With the chassis as reference point, start with the ohmmeter probe on the plate of the 6S7G tube. As in previous similar tests, a very low reading here means a short in condenser 12. The test could continue as in previous examples by moving the test probe along the circuit to find very low readings or points of lowest resistance to chassis. For instance, if the resistance to chassis at point *d* is lower than at points *p* or *e*, we know that the leakage must be in condenser 27. If point *e* gives a lower reading than *d* or *p*, the leakage must be in the power pack. This principle of searching for the point of lowest resistance to chassis is extremely useful for finding parts that are not completely shorted, when the leakage may be obscured by the resistance in the circuit.

The leakage through the electrolytic

condensers in the power pack should be always kept in mind when checking for shorts from the positive circuit to chassis.

A further useful procedure for finding leakage in a circuit where many parts might be involved, especially if a diagram is not available, is to disconnect parts so that individual circuits or parts can be tested alone. For instance, in Fig. 11, if there is a very low reading from point *f* to chassis, you could begin by unsoldering the choke 2 terminal from *f*. If this does not remove the short between *f* and the chassis, disconnect the lead to the other stages at *g*. If the low reading at *f* disappears, the short is beyond *g* in the other stages and can be run down. This method can be continued by disconnecting junctions right up to the plate of the tube until the short is found.

It is not advisable to make a continuity check of the grid circuit, due to the presence of the bias cell. Even the ohmmeter current flow through this kind of cell can ruin it. Never try to measure the voltage of a bias cell either, except with a vacuum tube voltmeter. If you notice the presence of a bias cell on the diagram or in the receiver, you will avoid using either an ohmmeter or voltmeter in any tests that put the bias cell in the test circuit.

Continuity can be checked through grid circuit parts 40 and 45 by placing one ohmmeter probe on the chassis and the other at point *h*, the junction of part 45 and the bias cell. A normal reading of about .5 megohm will be obtained with the volume control set at maximum, and about 50,000 ohms with the volume control set for minimum.

To test the voltage of a bias cell, if a vacuum tube voltmeter is not available measure the plate-cathode voltage with a d.c. voltmeter, first with the

cell in the circuit and then with the cell removed and the bias-cell socket terminals shorted or connected together. If there is no difference between the two readings the cell must be defective since the difference in plate current caused by a removal of bias should normally cause a sharp drop in the voltage at the plate. If the cell is defective, putting in a new one will cause the plate voltage to rise considerably and will clear up the distortion that is almost certain to be present with a defective cell.

If a new cell is not available, the cell can be replaced in most circuits by a high resistance, on the order of 10 megohms, and the bias is then obtained by convection current as in the circuit of Fig. 5. However, in Fig. 11, the high resistance cannot be placed

in series with the circuit. The problem is solved by placing a condenser of about .01 mfd. across the bias-cell socket, and connecting a resistor of about 10 to 15 megohms between grid and cathode as shown in Fig. 12. The bias cell is removed entirely. With a gassy tube, this system can never be used since the grid will go positive and the tube will soon be ruined.

**Electrode Voltage Tests.** Voltage tests in the stage of Fig. 11 can be made to chassis in the same way as in other receivers having the chassis in the d.c. supply circuit. The first check, as before, is usually from plate to chassis. Even though no voltage values are given on the diagram, comparative readings taken at points *f*, *d*, and the plate, will serve to isolate a defective part. For instance, if the plate reads

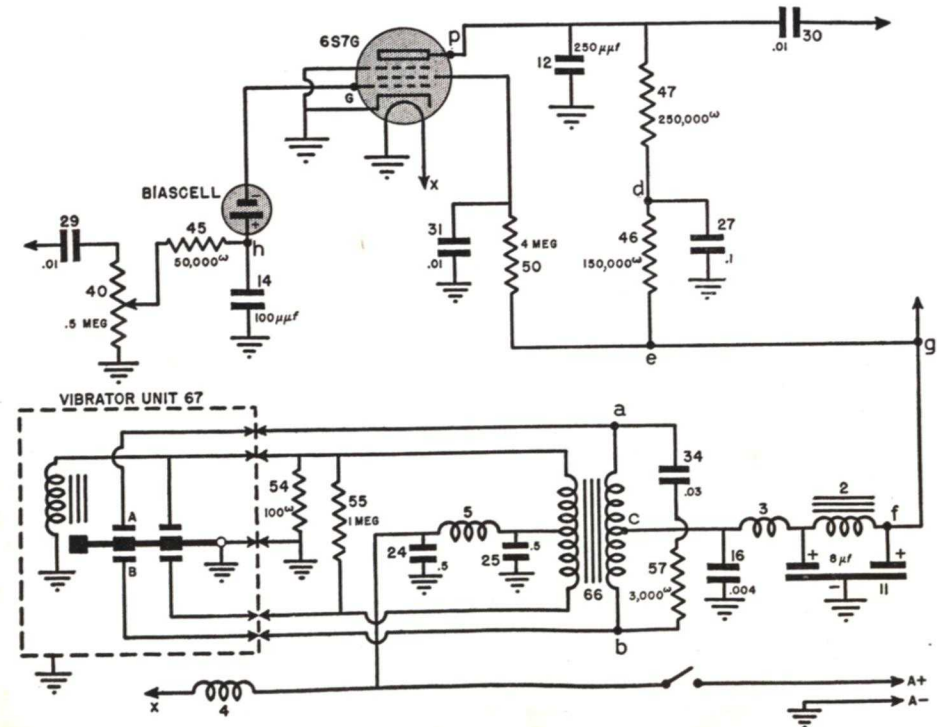

FIG. 11. Power supply and first a.f. stage of the Stewart Warner R-192-D vibrator-powered receiver

# Lesson Questions

Be sure to number your Answer Sheet 38RH-2.

Place your Student Number on every Answer Sheet.

Send in your set of answers for this lesson immediately after you finish them, as instructed in the Study Schedule. This will give you the greatest possible benefit from our speedy personal grading service.

1. A signal tracer measures a large i.f. signal between the screen grid and ground (chassis) of Fig. 1. Which part is defective and what is the matter with it?
2. If a receiver, using the a.v.c. circuit of Fig. 5, goes dead momentarily during strong bursts of static, which part is defective and what is the matter with it?
3. In Fig. 1, would you expect to get the same ohmmeter reading between each rectifier tube plate and chassis?
4. Name three easily identified points in Fig. 7 which could be used as the common *negative* reference point for ohmmeter measurements.
5. If an ohmmeter check between the plate and cathode of the 6K7G tube in Fig. 7 shows a resistance of about 35 ohms, what part is defective?
6. If resistor  $R_7$  of Fig. 7 is replaced, and the replacement smokes and overheats, what part is probably defective?
7. When checking across  $R_6$  of Fig. 9 with a voltmeter to determine if  $C_{16}$  is leaky, should the *positive* or the *negative* voltmeter terminal go to B —?
8. In Fig. 10, normal voltage is found between plate and B — but no voltage is between plate and chassis. What part is defective?
9. In the circuit shown in Fig. 11, what must be done before continuity measurements can be made, in addition to turning OFF the set?
10. With the tube in Fig. 11 removed, suppose your voltage readings between  $d$  and chassis are considerably lower than that between  $e$  and chassis. What other voltmeter reading will tell you whether the leakage is in condenser 12 or is in condenser 27?

no voltage and you find voltage at  $d$  and higher voltage at  $e$ , it is evident that condenser 12 is shorted. Or if the plate again shows no voltage and you get about the same reading at  $d$  and  $e$ , it is obvious that resistor 47 is open, as no current is flowing through 46. This is in line with the standard voltage procedure you have been learning all through this lesson and with your analysis of circuit action in the plate circuit.

If you found about the same voltage-to-chassis reading right up to the plate of the tube, for instance, it means that the circuit is unbroken and unshorted up to the tube terminal but that no tube plate current is flowing. This throws suspicion on the tube itself. To take the opposite case in which we suspect that leakage from the plate circuit to chassis is causing higher than normal current through 46 or 47, we could not tell accurately from voltage readings that leakage current existed because no voltage values are given on the diagram. However, by removing the tube from the socket, as previously explained, the normal plate current is interrupted and any remaining current through the plate circuit must be leakage current.

Remember from our previous example of this kind that measurements for voltage drop across resistors 47 and 46 should not be made by measuring to chassis with a low-resistance voltmeter, since the current through the meter will confuse the readings. The measurement can be made directly across the resistors themselves.

## LOOKING AHEAD

We have now completed the study of the basic testing methods and the

effect-to-cause reasoning which are needed to isolate the defective part and restore the receiver to operation that you, as a professional serviceman, will face in nine out of ten of the servicing jobs. These methods, if thoroughly understood and learned not by heart but so that you really know why they are used, will give you the ability you need for success. And never miss an opportunity to reread the sections that give you the theory of action in every kind of radio circuit, because in this way you will get the finest satisfaction that comes from radio, that of having the basic workings of radio at

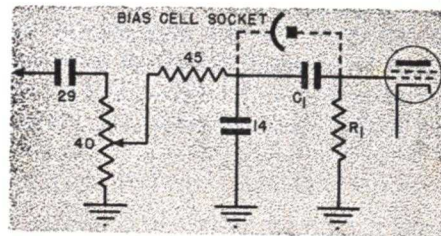

FIG. 12. Parts 29, 40, 45 and 14 are the same as in Fig. 11. Parts  $C_1$  and  $R_1$  are the extra parts used to obtain convection bias.

your fingertips so that you can enjoy being "in" on the thousands of new developments that come in this expanding science every year.

One more most important servicing procedure, the proper adjustment of trimmers—known as alignment—will be taken up in the next lesson. And then we will go on to those highly unusual troubles that require special testing methods and more detailed knowledge. We intend that the serviceman who makes an honest study of this Course shall never be "stymied" because he came up against a case that is far off the beaten run of the average serviceman's experience!





## MAKE BELIEVE IT'S TRUE

A young man once asked a successful friend to state just one rule for success. "*Look as though you have already succeeded,*" the friend advised. Following this rule eventually made this man president of a great bank in New York City.

As Shakespeare expresses it: "*Assume a virtue if you have it not.*" Dress like a successful man, act like a successful man. Be successful in all your thoughts, and you will be successful in the world as well.

David V. Bush states this same thought in terms of radio: "*If we think poverty thoughts, we become the sending and receiving station for poverty thoughts. We send out a 'poverty' mental wireless, and it reaches the consciousness of some poverty-stricken 'receiver.' We get what we think. If we are going to be timid, selfish, penurious and picayunish in our thinking, these thought waves will go forth until they come to a mental receiving station of the same caliber. 'Birds of a feather flock together,' and minds of like thinking are attracted one to the other.*"

Once you learn that you have a legitimate control over your own affairs, that you have the right to win, you will win.

*J. E. Smith*