

**LOW-FREQUENCY AMPLIFIERS
FOR SOUND AND
TELEVISION RECEIVERS**

15FR-2



NATIONAL RADIO INSTITUTE

WASHINGTON, D. C.

ESTABLISHED 1914

STUDY SCHEDULE NO. 15

For each study step, read the assigned pages first at your usual speed. Reread slowly one or more times. Finish with one quick reading to fix the important facts firmly in your mind, then answer the Lesson Questions for that step. Study each other step in this same way.

- 1. Low-Frequency Voltage Amplification Pages 1-8
The low-frequency amplifier consists of a voltage amplifier and an output stage. In this section you learn about the most popular voltage amplifier—the R-C coupled type—and learn how the fidelity of signal reproduction depends on parts values. Answer Lesson Questions 1 and 2.
- 2. More About Voltage Amplifiers Pages 8-13
Amplitude distortion; how stages are cascaded; and the fidelity of transformer-coupled and impedance-coupled voltage amplifiers, are the important subjects of this section. Answer Lesson Questions 3 and 4.
- 3. Single-ended Power Amplifiers Pages 13-19
Loudspeakers require signals with considerable power. Therefore, in sound receivers, the voltage amplifier supplies signal voltage to the grid of a power output tube. This section describes the differences between voltage amplifier and power stages. Answer Lesson Questions 5 and 6.
- 4. Push-Pull Power Stages Pages 19-25
The push-pull output connection offers higher power and better fidelity than does a single-ended power stage. Study this section carefully; there is much to learn about this important circuit. Answer Lesson Question 7.
- 5. Inverse Feedback Pages 25-30
Much of the distortion that arises in pentode and beam power output tubes can be eliminated by feeding back an out-of-phase signal so as to cancel some of the distortion. Here you learn how inverse feedback circuits of this kind work. Answer Lesson Question 8.
- 6. Phase Inverters Pages 31-34
Phase inverters are tube stages used in place of the input push-pull transformer. These stages reverse the signal phase 180° so that the push-pull grids may be properly driven. Answer Lesson Questions 9 and 10.
- 7. Facts about Low-Frequency Amplifiers Pages 34-36
This is a review section for the lesson. If you do not understand all of it, you should review the proper sections. Later on, this summary will help to refresh your mind on the basic characteristics of low-frequency amplifiers.
- 8. Mail your Answers for this Lesson to NRI for Grading.
- 9. Start Studying the Next Lesson.

COPYRIGHT 1946 BY NATIONAL RADIO INSTITUTE, WASHINGTON, D. C.

PM12M949

1950 Edition

Printed in U.S.A.

LOW-FREQUENCY AMPLIFIERS FOR SOUND AND TELEVISION RECEIVERS

Low-Frequency Voltage Amplification

RADIO signals go through several receiver sections to reach the low-frequency amplifier. As a review, you will recall that the signals (picked up by the receiving antenna) consist of radio frequency variations that follow the speech, picture, code, or music intelligence. The desired modulated carrier is selected and amplified by the r.f. and i.f. amplifiers. Next, the signal is fed into the demodulator (also called the detector). The demodulator stage eliminates the carrier, and produces a signal that is the electrical equivalent of the original intelligence—the signal can now be used to reproduce the sounds or picture we want, except that it is too weak to operate the reproducer. The job of the low-frequency amplifier is to increase the voltage or the power of this signal (from the demodulator) sufficiently to operate the reproducer.

Requirements. An increase in the signal voltage is all that is required to modulate the electron stream in the image reconstructor tube of a television set. However, the loudspeaker of a sound receiver may require considerable *power*—it is common to find sound receivers with power outputs ranging from 1 watt to as high as 10 or 12 watts. (Public address systems range up to 100 watts and more.)

By proper design, it is possible to obtain the necessary power from one or more “power” tubes, provided sufficient signal voltage can be applied to the control grid of this tube (or tubes). To obtain this signal voltage, the output of the demodulator is fed through

one or more *voltage* amplifier stages. These voltage amplifier stages plus the power output stage make up the complete low-frequency amplifier. (The cathode ray tube or picture reproducer is the output stage in a television receiver.)

Since the low-frequency amplifier deals with the electrical equivalent of the original intelligence, the amplifier must of course create as little distortion as possible. Amplitude and frequency distortion must be controlled in a sound receiver, and in a television set the designer must worry about phase distortion, also.*

► In this lesson, we shall study the complete low-frequency amplifier. (Future lessons will cover r.f. and i.f. amplifiers and demodulators.) We will begin with voltage amplifiers and then go into power stages.

We find that low-frequency *voltage* amplifiers are classified according to the devices used to couple the stages together. Thus, we have the resistance-capacitance coupled amplifier, the impedance-coupled amplifier, and the transformer-coupled amplifier. Of these the resistance-capacitance type (commonly known as the “resistance-coupled” or as the “R-C” amplifier) is the most widely used, so we will start with it.

*The low-frequency amplifier in a sound receiver is called the *audio amplifier* (because it handles frequencies corresponding to the audible range), and that in a television receiver is called the *video amplifier*

THE R-C AMPLIFIER

Fig. 1 shows the details of resistance-capacitance coupling, so named because resistors and condensers serve to couple one tube to another.

You have met the amplifier before, but let's study its operation in more detail. As you have learned, the filaments are supplied with heater power, even though it is customary not to show the filament connections on schematic diagrams of the kind shown in Fig. 1. (This is purely a convenience to avoid complicating the diagram when it is being used to study the signal paths.) The plate supply is indicated by the signs $B+$ and $B-$. Grid bias is obtained from the self-bias resistors R_2 (for VT_1) and R_5 (for VT_2). The a.c. components of the plate currents are by-passed around these resistors by C_2 and C_5 respectively. That is, there is only a small a.c. voltage drop between the tube cathodes and $B-$, because the reactances of the condensers are lower than the resistances of the resistors they by-pass. However, the d.c. current has to flow through the bias resistors, and the resistor values are chosen so that they provide the voltage drop needed to furnish the desired grid bias.

► The input signal voltage e causes a signal current to flow through C_1 and R_1 . The resulting voltage drop across grid resistor R_1 becomes the grid signal voltage for VT_1 . (The signal current is a.c., so it "passes through" the condenser. Hence, the entire a.c. voltage e appears across R_1 except for the portion lost in the reactance of the condenser, as we shall soon show.) Tube VT_1 amplifies the signal, so an amplified version appears across plate load resistor R_3 . This load a.c. voltage causes a signal current to pass through condensers C_3 and C_4 , and grid resistor R_4 . The resulting voltage across R_4

becomes input for VT_2 .

Condenser C_3 is called the *coupling condenser* because it "couples" the circuits of VT_1 to those of VT_2 . Condenser C_4 also could be considered as a coupling condenser, but instead it is called a by-pass condenser, because it is primarily selected to by-pass the signal so that the signal current does not flow through the B supply. (This condenser completes the a.c. circuit to ground, so that the signal is directly applied to the grounded end of resistor R_4 .) This completes the passage of the signal through the stage using VT_1 ; it now is acted upon by VT_2 .

Frequency Band. Before we can determine the gain of the stage using tube VT_1 , we must consider the range or "band" of frequencies that this amplifier is called upon to pass.

The use to which the receiver is put determines the width of the band of frequencies that the low-frequency amplifier must pass. Communications receivers, intended only for the reception of voice or code signals, have to amplify only those frequencies between about 200 and 3000 cycles.*

Sound receivers for the home must amplify a wider band for musical reproduction. Although sound frequencies range from 30 cycles to above 16,000 cycles, the average inexpensive radio is limited to a frequency range of from about 200 cycles to 5000 or 6000 cycles. Some of the better receivers, including the average f.m. receiver, have ranges of 50 cycles to 8000 cycles. A few high-fidelity a.m. and f.m. receivers have a range of from 30 to 16,000 cycles.

In television, the desired frequency band ranges from 10 cycles to near 4,000,000 cycles. This band is so wide

*Like most radio men, we use "cycles" for "cycles per second," which is the correct term.

that special compensators are necessary, as we shall soon see.

► Even though the low-frequency amplifier is intended to pass a particular band of frequencies (as we just described), the amount that it amplifies the higher and lower frequencies in this band is different from the amplification given to frequencies in the middle of the band. That is, it is not perfect in its frequency response, and it may not be economical to improve the response beyond a predetermined level. Therefore, the parts are chosen to give a certain response, and this places limits on the replacement values that

come from changes in the load, or from voltage-dividing networks that vary with frequency. Let's see what occurs in our R-C amplifier of Fig. 1.

Mid-Frequency Response. First, let's consider the response to frequencies in the middle of the band. If the amplifier is designed to pass (reasonably well) frequencies between 100 cycles and 5000 cycles, then we can call frequencies from 1000 to 3000 cycles the mid frequencies.

When we examine the parts values used in an R-C amplifier in an a.m. or f.m. receiver, we find that the capacity used as C_4 in Fig. 1 is always so large

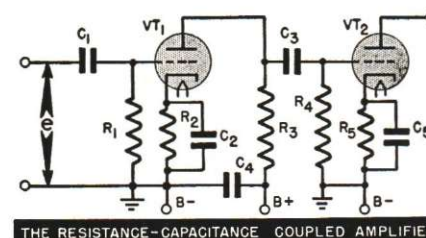

FIG. 1. This R-C coupled amplifier is the basic circuit found in most sound and television low-frequency amplifiers.

can be used. Hence, it is advisable to learn more about how an R-C amplifier (as found in a.m. and f.m. receivers) responds to the middle, low, and high frequencies in its pass band.

FREQUENCY RESPONSE

You know that the gain of a stage depends on the amplification factor (μ) of the tube, the tube's plate resistance, and the value of the load impedance. The grid voltage is stepped up by the factor μ , and the resulting equivalent a.c. plate voltage (μe_g) is then divided between the plate resistance and the load. Therefore, since μ and the plate resistance remain the same almost regardless of frequency, any change in the over-all gain must

that this condenser has negligible reactance to all frequencies in the band to be passed. Also, C_3 has little opposition to the mid frequencies, so there is practically no reactance between R_3 and R_4 at these mid frequencies. Therefore, insofar as a mid-frequency signal is concerned, R_4 is connected in parallel with R_3 and the combination forms the load for VT_1 . Thus, the equivalent circuit at the mid frequencies is as shown in Fig. 2A.

You will recall that the higher the load resistance is made, the greater the voltage gain will be. In fact, we get almost 90% of the μ of the tube as a stage gain when the load resistance is 10 times the a.c. plate resistance r_p . So you might think that we need only to increase the values of R_3 and R_4 in or-

der to get more gain. That is true, but there are practical limits on the values we can use—we will take these up after we see what happens at the low and high frequencies.

Low-Frequency Response. When we go down to low frequencies (those lower than the mid frequencies) we find that the coupling condenser (C_3 in Fig. 1) comes back into the picture, because, as the frequency decreases, the condenser reactance increases. Hence, it begins to act with R_4 as a voltage divider. In other words, as shown by the equivalent circuit of Fig. 2B, the signal voltage developed across plate resistor R_3 is actually fed into a filter C_3 - R_4 , which passes higher frequencies better than lower frequencies. As the frequency decreases, the reactance of C_3 increases; a greater proportion of the signal voltage is then dropped across C_3 , and less appears across R_4 . Since VT_2 is operated *only* by the signal voltage across its grid resistor R_4 , the less this voltage is, the lower the VT_2 input signal will be. Therefore, there is less voltage fed to VT_2 , so the over-all grid-to-grid (VT_1 to VT_2) gain is less, and the gain drops still more as the frequency is decreased further. Hence, in the low-frequency range, this circuit has frequency distortion (unequal amplification of different frequencies).

High-Frequency Response. The equivalent circuit for high frequencies is given in Fig. 2C. Condenser C_3 is no bother because its reactance at high frequencies is negligible. However, we now have a new factor, the capacity C_s , which represents a number of different tube and stray circuit capacities that we have lumped together for convenience. These capacities do not appear in Fig. 1 (we will explain them shortly), but you can see their result at once. Since the reactance of C_s de-

creases as frequency is increased, it will act as a shunt across the resistors at higher frequencies. In effect, this reduces the load value at higher frequencies, so more and more of the signal voltage will be lost across r_p within tube VT_1 . Hence we have frequency distortion at the higher frequencies also, but from another cause.

► We have given the three equivalent circuits together in one drawing so that you can compare them with each other. Notice that the schematic (Fig. 1) shows the electrical connections, but *does not directly indicate how the circuit will act at different frequencies.* Even the equivalent circuits of Fig. 2 indicate only the trend of operation; until parts values are known we cannot tell how serious the frequency distortion may be. As we will now show, *changing the parts values will radically change the response.*

EFFECT OF PARTS VALUES

We can continue to assume that C_4 in Fig. 1 is sufficiently high in capacity to have no effect on any frequencies the amplifier is designed to pass. Therefore, we can concentrate on the limits set for the parts R_3 , R_4 , C_3 , and C_s of Figs. 1 and 2.

Value of R_3 . The value of the load is one of the factors that determine the stage gain. Since we want the stage to amplify, you might imagine that the value of plate resistor R_3 should be high. It is desirable to have this a high resistance at the middle and low frequencies, but not at the higher frequencies. This is because the higher the resistive load is, the sooner C_s becomes an effective shunt. This effect is shown by Fig. 3. Here, curve A shows the frequency response for a high load resistance, and curve B the response for a much lower load resistance (assuming the same value of C_s in each case).

Naturally, the higher the load resistance is, the higher the amplification at the mid frequencies. Therefore, curve A shows fairly high gain at around 2000 cycles—higher than that shown by curve B.

However, compare the output at 2000 cycles with that at 5000 cycles for

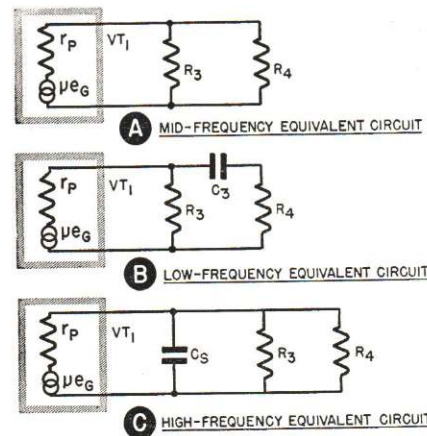

FIG. 2. The R-C amplifier responds differently to the high, middle, and low frequencies in its pass band. These equivalent circuits show how the circuit components affect the response.

curve A. There is a severe loss of higher frequencies (frequency distortion) beginning at about 4000 cycles. On the other hand, curve B shows a much smaller *difference* between the mid-frequency response and that at 5000 cycles. In other words, the gain shown by curve B drops only from 5 to about 3 in the range from 2000 to 5000 cycles, whereas the gain shown by curve A changes from 10 to about 3 over the same frequency range.

The ideal amplifier—one having no frequency distortion—would amplify *all* frequencies in its pass band equally. Hence, curve B approaches the ideal more closely than does curve A. This shows that there is good reason for keeping the effective load for the stage low when high fidelity is desired. (However, this reduces gain, and often

a compromise is necessary to get reasonable gain with good fidelity.)

► In addition, the d.c. plate current of VT_1 passes through R_3 , and this brings up a power supply problem. The drop in R_3 (caused by the d.c. plate current) is subtracted from the B supply voltage. The remainder is the plate-cathode voltage actually supplied to the tube, and we want this voltage to be reasonably high. Since there are limits to the power supply voltage, the value of R_3 must be kept down to avoid too much d.c. voltage drop. The most common values in a.m. and f.m. home receivers range from 50,000 ohms to 250,000 ohms. Therefore, the gain of a practical R-C amplifier stage is not as high as is theoretically obtainable.

Value of R_4 . Increasing the resistance of R_4 seems to be another way of

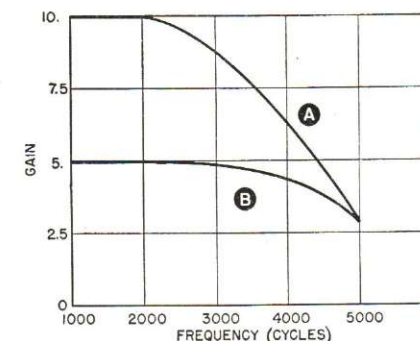

FIG. 3. Using a higher load value gives greater gain (curve A), but there is a more rapid drop-off in the high-frequency response.

getting a higher load value, since this resistor is in parallel with R_3 , and in addition, no d.c. is supposed to flow through it. However, if the following tube (VT_2 in Fig. 1) is a power tube, we may encounter gas trouble.

No matter how well a tube is evacuated in manufacture, some gas (air) remains in it. The heat of operation may drive gas molecules out of the

"pores" of the metal elements. When the gas level upsets operating conditions, we say that the tube is "gassy." This trouble occurs particularly with power tubes because of their high current levels.

When the tube becomes gassy, speeding electrons strike the gas molecules and knock out electrons, leaving positive gas ions. The positive gas ions move toward the cathode, but some "capture" electrons from the grid. This causes an external electron flow to the grid element. This electron flow must pass through R_4 , and therefore, develops a voltage across it. The grid current may be quite small at first. However, if resistor R_4 is very high in value, then even a very small gas current will cause an appreciable drop across it.

The voltage drop that occurs when the tube is gassy has a polarity that makes the grid end of R_4 positive. Hence, the drop opposes the bias voltage, and causes a reduction of the grid bias. Consequently, there is an increase in plate current. Eventually, the higher than normal plate current, and the bombardment of the cathode by the heavy gas ions will destroy the emissive properties of the cathode and thus ruin the tube.

For this reason, there is a definite upper limit to the size R_4 can have. If tube VT_2 is a power tube, R_4 must be no more than 100,000 ohms to 250,000 ohms in most cases.

If the tube is not a power tube, there is less gas trouble, and R_4 can be larger in value. You may find voltage amplifiers using values from 250,000 ohms to as high as 10 megohms.

Value of C_3 . The value of C_3 needed for good low-frequency response depends on the value of R_4 . If R_4 can be a high resistance, then even a small capacity can be used without

excessive loss of the low frequencies. However, we have just shown that R_4 cannot always be made so large; therefore, C_3 may have to be fairly high in capacity.

► The low-frequency response of a radio receiver depends on the design of a number of things—the large amount of audio power needed for good low-frequency response requires an oversized loudspeaker, a large power supply, a high-power output stage, and a large console with a specially designed speaker compartment. All these items are costly, a fact that explains why the low-frequency response is sacrificed in the average receiver.

Once the limits have been set by the design of these components, there is no reason for making the voltage amplifier too perfect in its response; in fact, it is better *not* to have the low-frequency response too good, because if the amplifier can amplify very low frequencies, slight changes in the power supply voltages may cause it to oscillate. This oscillation prevents the passage of the signal, so all that can be heard is either a low-frequency howl or a "putt-putt-putt" sound called *motorboating*. Therefore, C_3 and C_1 of Fig. 1 are made no larger than necessary in practical amplifiers. Values found in the average radio are from .005 mfd. to perhaps .1 mfd., with the most common values being .01 or .05 mfd.

Value of C_s . The shunt capacity C_s is made up of the inter-electrode capacities within the tubes, and the capacities between wires and parts in the circuit.

The tube inter-electrode capacities are shown for a triode tube in Fig. 4. You will recall that a capacity exists between any two conductors separated by an insulator. Therefore, the metallic tube elements, separated by a vacuum,

form tiny condensers. As shown by Fig. 5, the capacity between the grid and the cathode (called C_{GK}) is across the input circuit, and the capacity between the plate and the cathode (called C_{PK}) is across the output circuit. Even worse is the capacity between the grid and the plate (C_{GP}). Notice that this capacity acts as a coupling condenser between R_L and the input, so that part of any a.c. voltage across R_L will also be across the input. This means that part of the amplified signal voltage across the load will feed back to the input circuit through C_{GP} . Because of the phase relationships involved, the reaction of this feedback voltage on the input is such that the circuit acts as if the input capacity of the tube were far higher than the measured capacity between the grid and the cathode elements.

► Therefore, going back to Fig. 1, tube VT_2 acts as if it had a high capacity between its grid and its cathode, in parallel with R_4 . Also, tube VT_1 has an output capacity between its plate and

the stray capacity will likewise be minimized.)

Since the output capacity of VT_1 and the input capacity of VT_2 are in parallel, they can be lumped together and considered as a single condenser. Therefore, at high frequencies, the circuit is equivalent to that shown in Fig. 2C, where capacity C_s represents all the shunting capacities.

► Set designers make every effort to minimize the value of C_s . Once this

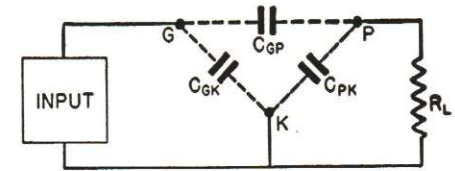

FIG. 5. The plate-grid inter-electrode capacity provides a coupling path so that the voltage across the load is transferred to the input circuit.

value is determined, it fixes the largest values of R_3 and R_4 that can be used and still have the required fidelity.

Summary. Tube VT_1 is usually chosen to be a high- μ triode (or pentode in some cases). Tubes with high gain and low d.c. current values have been specially designed for use in R-C amplifiers. Even so, fidelity compromises mean that R-C amplifiers are used where gain is less important than fidelity, because it is possible to get good fidelity, despite what has just been shown, if the gain can be sacrificed. Hence, we can make the following rules for circuits like that in Fig. 1:

1. For maximum gain at the middle and low frequencies, R_3 and R_4 should be high in resistance.

2. For minimum loss of high frequencies, R_3 should be low in resistance.

3. The larger C_3 is in capacity, the better is the low-frequency response.

► As a serviceman, you will have to replace these parts whenever defects

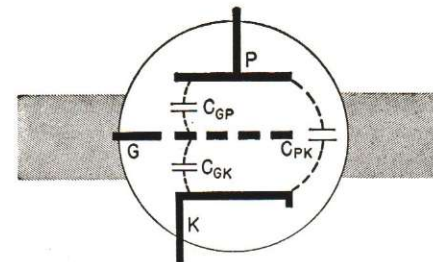

FIG. 4. The inter-electrode capacities within a triode tube.

its cathode (across R_3), and there is stray capacity between the chassis and the wiring and parts. (Coupling condenser C_3 is the most bulky part, so a considerable amount of stray capacity exists between it and the chassis. This is another reason for choosing C_3 with a capacity that is no larger than necessary—if its physical size is kept down,

occur in them. You should use replacements having values within 20% of the original values if you do not wish to change the circuit characteristics. If you do want to make a change, or if you do not know the original values, the rules just given will help you

choose the best replacements for the desired conditions. When you install replacements, take care to minimize the shunting capacity C_s . Don't add more wire than necessary, and don't disturb positions of parts more than is necessary.

More About Voltage Amplifiers

So far, we have considered the frequency response and frequency distortion of a resistance-coupled amplifier. Equally important is the amplitude distortion that can occur—in fact, even small amounts of amplitude distortion can be far more objectionable than fairly large amounts of frequency distortion. Let's continue with the resistance-coupled voltage amplifier as our example, and learn more about amplitude distortion.

AMPLITUDE DISTORTION IN R-C AMPLIFIERS

You know that amplitude distortion is produced whenever the wave shape of a signal is changed. This distortion will occur whenever the tube's operating characteristic is curved. Therefore, to minimize the distortion, operation is limited to the straightest portion of a tube's characteristic.

► However, so far we have presented the darker side of this story because we have shown you only the characteristic curve of the tube *alone*. Such "static" characteristic curves show how the tube operates when there is *no plate load*. These curves are the kind the tube manufacturer can most easily furnish since he doesn't know just what load values may be chosen by the set designer. However, when the tube is operated with a load (the normal condition) its operation is over a "dy-

dynamic" characteristic that is considerably different in shape. Naturally, we are interested in dynamic curves because they show how a tube actually operates in a stage.

Dynamic curves can be found by actually setting up the circuit and measuring the response, or they can be plotted from the static curves. We won't go into their construction here, but the following facts will show why they differ so much from the static curves.

First, you know that the plate current of a tube with no load increases rapidly as the grid bias is made less negative. Curve A of Fig. 6 is a typical static curve, showing how the plate current and the grid voltage are related when the tube plate voltage is a fixed amount.

Next, you have learned that when a load resistor is used, some of the B supply voltage is dropped across it because the tube plate current flows through this resistor. Therefore, the actual plate-cathode voltage of a tube is the difference between the d.c. load drop and the supply voltage.

► Now, let's suppose we change the bias so that the grid is made less negative. Since the plate current tends to increase when the bias is less negative, there will be a greater drop across the load resistor, so the actual tube plate voltage drops. This reduction in plate

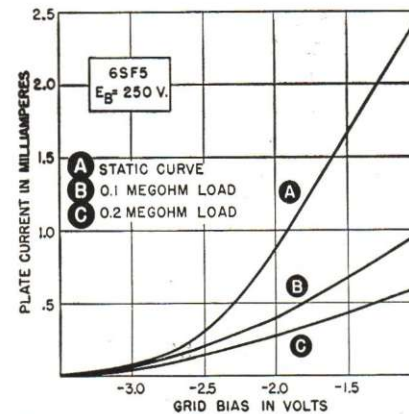

FIG. 6. Curves B and C show how increasing the load resistance tends to flatten the tube E_b - I_p characteristic curve.

voltage counteracts some of the plate current change (the plate current depends on both the grid voltage and the plate voltage) so the actual change in current for a particular grid voltage change is not as large when a load is used.

Hence, when a load is used, the tube characteristic is "ironed out" so that it is much flatter and straighter than the static curve. The effect of this self-regulation is shown in Fig. 6, where curves B and C represent dynamic curves for two different load values for a triode tube.

You can see that there is far less curvature in these dynamic curves than there is in curve A. This means that there will be much less amplitude distortion when a load is used. That is, a change in grid voltage (such as is

caused by a signal) will cause much more nearly linear plate current changes.

► Furthermore, the higher the load resistance is, the flatter the curve. However, this brings back our compromise conditions; you know that high resistances cause excessive loss of the higher frequencies. Therefore, the designer must consider gain, frequency distortion, and amplitude distortion when he chooses values for the tube load.

CASCADE AMPLIFIERS

These factors are further complicated when there is more than one stage of R-C amplification. For example, suppose we have two stages, as shown in Fig. 7. We'll consider tubes VT_1 and VT_2 to be the voltage amplifying tubes for these stages, with VT_3 shown only to indicate the output coupling. Furthermore, let's assume that the characteristics of *corresponding* parts are alike: that is, the tubes are the same, condensers C_4 and C_7 have the same capacity, and resistors R_3 and R_6 have the same resistance, as do R_4 and R_7 .

The first thing we are interested in is the amount of amplification we get. Let's suppose that each of the stages is capable of giving a gain of 10 at the mid frequencies, and that a signal of 1 volt is applied to the input of VT_1 . There will be a signal of 10 volts across R_3 ; this voltage is applied to tube VT_2 .

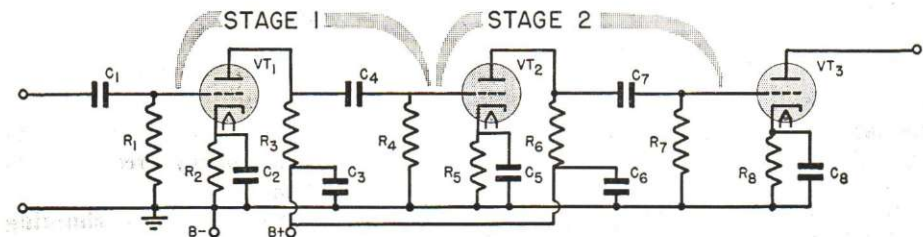

FIG. 7. A two-stage R-C amplifier.

This tube also has a gain of 10, so its 10-volt grid signal is raised to 100 volts* across R_6 . Thus, the gain of successive stages is the *product* of their respective gains; the gain of the VT_1 stage is multiplied by the gain of the VT_2 stage ($10 \times 10 = 100$ and our 1-volt signal was raised to 100 volts).

When more than one stage is used, we say that the stages are "in cascade," because each one steps up the signal output of the previous ones by its own gain factor.

Fidelity. From this, we might at once assume that all we need to do to

with two stages it will be one-quarter (one-half times one-half) that of the mid frequencies.

► This is one of the reasons why the number of low-frequency amplifier stages is kept at a minimum in radio receivers. It is far better to use a single high- μ triode or pentode tube than to use two or more stages of low-gain triode tubes.

TELEVISION AMPLIFIERS

Although careful design is necessary to have high fidelity in a resistance-

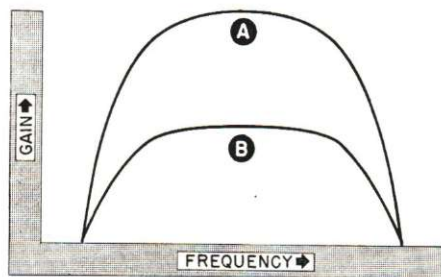

FIG. 8. Curve A shows that there is a higher mid-frequency gain when two stages are used, but there is a more rapid drop-off at the lower and higher frequencies.

obtain more gain is to add more stages. However, if we do, we find that the fidelity becomes much worse when more than a single stage is used.

For example, see Fig. 8. Curve B represents the fidelity of a single stage, and curve A represents that of two identical stages. Curve A shows that the gain is increased at the mid frequencies, but you can see that the addition of another stage exaggerates the frequency distortion already present at the low and high frequencies in one stage. Thus, if the gain at some particular frequency is only half that of the mid frequencies in a single stage,

*If the input was .01 volt, the output of VT_1 would be .1 volt, and the output of VT_2 would be 1.0 volt.

coupled amplifier, this circuit still offers a greater range of frequency response than any other, so it is universally used (in a modified form) as the video intelligence signal amplifier in television receivers. We will leave complete details for later lessons, but some of the methods used to get a broad frequency pass band are of particular interest at this time.

For television, the frequency range is from about 10 cycles to as high as 3,000,000 or 4,000,000 cycles. This is many times greater than that found in any sound receiver. Getting this extended high-frequency response is quite a problem.

To reduce the effect of the shunting capacity (corresponding to C_s in Fig.

9C) and thus obtain better high-frequency response, a very small load resistor (1000 to 5000 ohms) is used. This means extremely low gain unless special high mutual-conductance pentode tubes are used.

Other steps are also taken to reduce the effects of the shunt capacity. As you learned, the shunt capacity is due

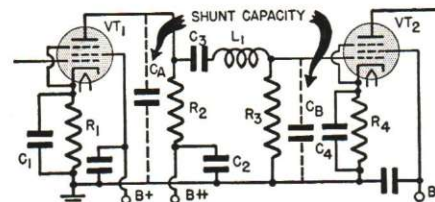

FIG. 9. The effects of the shunt capacities C_A and C_B are reduced by using L_1 .

partly to the output capacity of one tube and partly to the input capacity of the other. In Fig. 9, these capacities are represented as C_A and C_B . One scheme used is to insert a coil (L_1 in Fig. 9) between the plate circuit of VT_1 and the grid circuit of VT_2 . This serves to isolate C_B from R_2 , so it reduces the effects of C_B on the load of VT_1 . The isolation increases with frequency increases because the reactance of L_1 increases with frequency. Hence, its increasing reactance counteracts the decreases of the C_B reactance insofar as VT_1 is concerned.

Also it is possible to make L_1 and C_B resonant at some rather high frequency. This forms a series resonant circuit so that a maximum voltage appears across C_B at the resonant frequency. This voltage is applied to VT_2 , so the response at and near this resonant frequency is improved.

► Another scheme is shown in Fig. 10. Here, coil L_2 is placed in series with R_2 . As the frequency increases, so does the reactance of L_2 . Therefore, as L_2 is part of the load, the load impedance rises as the frequency increases. Al-

though the shunting effects of the stray capacity are increased, there is a better division of the μ_G voltage between the r_p of VT_1 and the load, so the VT_1 stage provides higher gain at the higher frequencies. This tends to minimize the drop-off in high-frequency response. Furthermore, by making L_2 resonant with C_A (at a high frequency), a parallel resonant circuit is formed. This provides a rise in the load resistance at resonance, which in turn further boosts the gain at the high frequencies. Sometimes both schemes shown in Figs. 9 and 10 are used in the same amplifier.

► In addition to these methods of reducing shunt capacity effects, television engineers use sockets that have low capacity to chassis, and mount parts so that they are separated from the chassis as much as possible, yet try to keep the leads between stages short to avoid capacity between these leads and other wires. These precautions are necessary because of the very wide

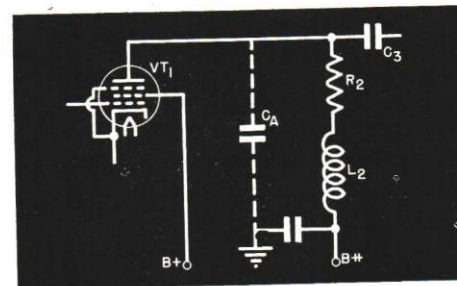

FIG. 10. Another compensation for shunt capacity is to use L_2 in series with the load resistance.

band of frequencies passed by the television amplifier. Naturally, it is not necessary to go to such extremes in ordinary sound receivers.

USING COILS FOR COUPLING

The resistance coupling you have just studied is the coupling method most commonly used today for voltage amplifiers. However, some amplifiers

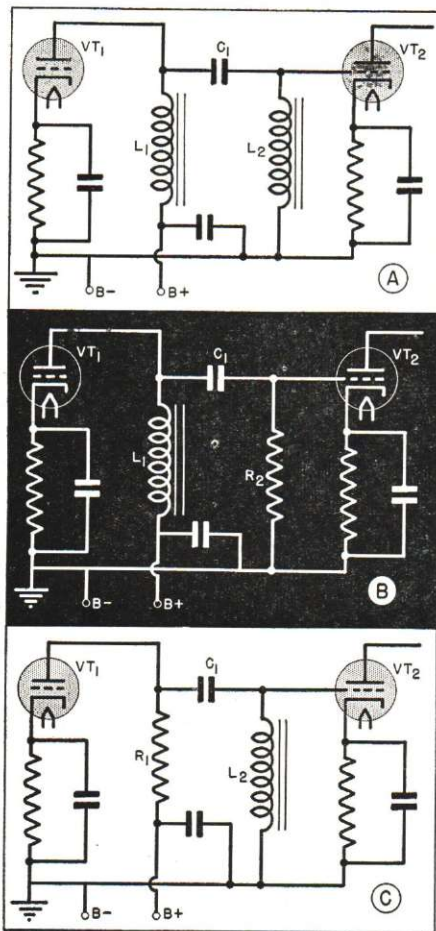

FIG. 11. Three forms of impedance coupling are used in low-frequency amplifiers.

use inductances (coils) for coupling. Some of these inductances are choke coils, others are transformers—we will study both.

Impedance Coupling. Essentially, an impedance-coupled amplifier is like a resistance-coupled amplifier except for the substitution of one or more iron-core choke coils for the resistors. Fig. 11A shows a full impedance-coupled amplifier. Here choke coil L_1 is used as the plate coil, and choke coil L_2 is used as a grid coil for tube VT_2 . The operation is similar to that of re-

sistance coupling except for the effects of the coils on the frequency response, and the effect of L_1 on the plate voltage.

Since L_1 has a low d.c. resistance, there will be very little d.c. voltage drop across it. Practically the full supply voltage is applied to the plate of the tube. For this reason, this circuit is particularly useful where the B supply is very limited, as in battery-powered circuits.

Coil L_2 also has a low d.c. resistance. Therefore, any gas current flowing through L_2 will cause but a small voltage drop, so the use of a coil eliminates the bias shift encountered when a grid resistor is used with a gassy tube.

► Since both choke coils offer higher reactances as the frequency increases, we might expect the gain of the stage to go up as the frequency rises. However, good high-frequency response is not obtained, because the choke coils have rather high distributed capacities, which are effectively in parallel with the coils. The distributed capacity tends to cut off the high-frequency response even more rapidly than in a resistance-coupled amplifier, because the coil capacities are added to the normal shunting capacities in the circuit.

The low-frequency response is poor also, because the reactance values drop at low frequencies. Hence, unless very large values of inductance are used, the low-frequency response will be much poorer than that of the mid frequencies.

Fig. 11B shows a variation of this circuit in which coil L_2 is replaced by resistor R_2 . This eliminates the distributed capacity and inductance troubles of one of the choke coils, so this circuit is somewhat better in frequency response than that shown in Fig. 11A.

This is the impedance-coupled circuit most likely to be found in use, for it is considerably cheaper than the one in Fig. 11A.

Fig. 11C shows another possible variation, in which coil L_1 is replaced by resistor R_1 . (Choke L_2 is used as the grid coil.) This circuit has little to recommend it unless tube VT_2 is likely to be gassy and a high resistance is not wanted in the grid circuit.

Transformer Coupling. Fig. 12 shows an example of a transformer-coupled voltage-amplifier stage. As you learned in an earlier lesson, transformers have a special kind of amplification also; they can step up the signal voltage by their turns ratio.

Therefore, if tube VT_1 in Fig. 12 has a gain of 10, and the transformer T_2 a step-up ratio of 3, the first stage gain will be the product of the two, or 30. Hence, transformer-coupled amplifiers give much higher gain for the same type of tube than do either impedance-coupled or resistance-coupled amplifiers.

As you learned in an earlier lesson, the frequency response of a transform-

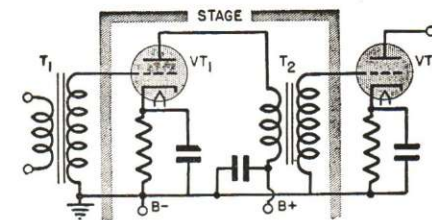

FIG. 12. A typical transformer-coupled, low-frequency, amplifier stage.

er is limited. The inductance of the primary winding must be very high to prevent an excessive loss of low frequencies because of the voltage division between the primary and the plate resistance of tube VT_1 . In addition, the distributed capacity of the windings must be low to prevent an excessive loss of the high frequencies. Essentially, transformers give a frequency response similar to that obtained with impedance coupling.

► The resistance-coupled amplifier offers far better fidelity than either of the devices using iron-core coils. However, the high amplification obtainable from the transformer makes it a favorite where gain is more important than frequency response.

Single-Ended Power Amplifiers

Once the voltage amplifier has made the signal sufficiently large, the voltage is fed into a power stage which supplies the power to drive the reproducer (a loudspeaker in a sound receiver). On paper, the power stage diagram is very similar to that of the other audio stages. It is not until we notice the plate current values and bias voltages that we see the difference.

Modern receiver loudspeakers require a considerable amount of a.f. power—anywhere from 1 watt to 12 watts on maximum output levels.ordi-

nary *voltage* amplifying tubes cannot furnish anywhere near **this power**. Most of them draw only from .25 watt to about 1 watt of d.c. power. This power is found by multiplying the B supply voltage by the d.c. plate current. For example, if the B supply voltage is 250 volts, and the d.c. plate current is 1 ma. (.001 amp.), then the d.c. power is $250 \times .001$, or .25 watt.

The total developed a.f. power is always far less than the d.c. power, and at least half the a.f. power is lost in the plate resistance of the tube. There-

fore, we must use an output tube capable of delivering a higher power than can a voltage amplifier.

This means a power tube must draw a higher d.c. power than a voltage amplifier in order to deliver the required a.c. power. Since it is desirable to operate all the stages at the same plate voltage to simplify power pack

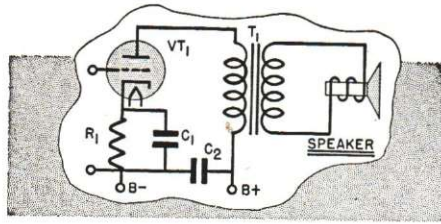

FIG. 13. The voice coil of the loudspeaker is matched to the plate impedance of the output tube by the output transformer.

design, power tubes are designed to draw more plate current. (Power is equal to voltage times current, so increasing the current increases the power.)

► To get the increased emission, the size (length and diameter) of the cathode is increased, and the filament current is increased to the value needed to heat the larger cathode. Then, the plate area is increased to correspond to the increased cathode size. This provides more electron paths (in parallel) from the electron cloud to the plate, and, as the same plate voltage acts across each, this has the effect of resistance in parallel—there is less plate-cathode resistance, so the plate current is higher for the same plate voltage.

For comparison, audio voltage amplifying tubes in radio receivers draw currents of from .5 ma. to perhaps 5 ma., but power output tubes draw currents of 30 to 50 ma. and more.

Coupling to Speaker. Fig. 13 shows the method of coupling from the plate of a power tube to the voice coil of a dynamic loudspeaker. Usually a

voice coil has an impedance of only 4 to 8 ohms, which is far lower than the plate resistance of the tube. Transformer T_1 is used to match the two impedances.

Load Matching. As you know, maximum power output is obtained when the load impedance exactly matches the plate resistance of the tube. This does not assure minimum amplitude distortion. However, you will recall that increasing the load re-

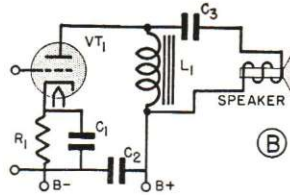
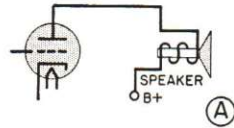

Magnetic speakers were once very popular, and in radio servicing you may still encounter a receiver using one. An output transformer is not needed with them—they are made with many turns of wire, so it is possible for them to have impedances of 2000 to 6000 ohms, which is a close match to the required load for output tubes. In the direct coupling shown at A, the d.c. plate current flows through the speaker. This may be undesirable, for, if the wrong connections are made, the resulting d.c. flux will be opposite to that of the permanent magnet used in the speaker. This may ruin the speaker magnet. Also, the high current requires large wire sizes, which may make it difficult to wind the coil in the space provided. Hence, many sets used the choke-condenser coupling shown at B to avoid this; here the d.c. is blocked by C_3 and flows only through L_1 .

istance value tends to flatten the triode tube characteristic curve. Therefore, it has been found that with triode tubes, a load equal to about twice the plate resistance value will give the maximum undistorted power output.

Notice the difference. The maximum power, with some distortion, is ob-

tained when the load and source values are matched. The maximum undistorted power (less than the maximum power but with less distortion) is obtained when the load is twice the tube resistance. (Further increasing the load resistance reduces the distortion some more, but the power output falls off because of the mismatched impedances.)

The load values and operating voltages listed in tube charts for triode power tubes are for the maximum undistorted power output, and the output transformer is designed for these values.

PENTODE AND BEAM POWER-OUTPUT TUBES

The triode power-output tube offers very good fidelity, but it requires a high signal input to be driven to its full output. Also, it consumes a considerable amount of d.c. power. The latter is no problem in a large receiver with a heavy-duty pack, but is troublesome in a set using battery or a.c.-d.c. supplies, which are limited in their power. For these reasons, pentode and beam power tubes having higher efficiencies than triodes* were developed.

The pentode and beam tube types require considerably less grid signal voltage than does a triode to produce the same output. For example, the type 2A3 triode tube requires a grid signal having a peak value of nearly 45 volts to give 3.5 watts output. On the other hand, the 6K6G pentode power tube requires a signal of only

* For comparison, the a.c. power output (with permissible distortion levels in the case of the pentode) of the 6K6G pentode and the 2A3 triode are similar (about 3.5 watts). With the same plate voltage, the 2A3 draws 60 ma., but the 6K6G draws only 32 ma. The d.c. powers used, at 250 volts, are 15 watts for the 2A3, and 8 watts for the pentode.

about 18 volts peak to give 3.5 watts output.

This is important because it leads to a simpler voltage-amplifier design. In most receivers, one voltage-amplifier stage is plenty with pentode or beam output tubes, but triode output tubes frequently require two.

The Pentode Tube. Fig. 14 shows an output stage using a typical power pentode tube. As you will notice, this tube has three grids. From the cathode toward the plate, these grids are, respectively, the control grid, the screen grid, and the suppressor grid.

The control grid performs the same

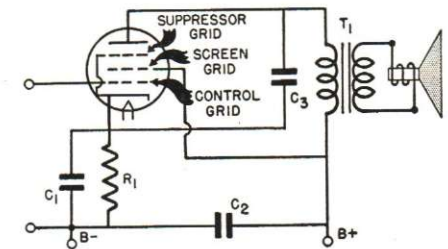

FIG. 14. The elements of a pentode power output tube are identified.

function as it does in a triode tube.

► The screen grid is a relatively coarse grid that is connected to a positive voltage—the screens of power types are usually connected directly to B+. Its high potential causes it to draw electrons from the electron cloud. The screen grid catches some of these, but because of its coarse structure (widely separated turns of wire) most of the electrons go through the mesh to the plate.

Since the screen grid is considerably closer to the cathode than the plate is, the plate current is much more dependent on the screen grid voltage than it is on the plate voltage. If the screen grid voltage is kept constant, the plate voltage can be varied over rather wide

limits without changing the plate current to any considerable extent.

Hence, in pentodes, the control grid has far more effect on the plate current than does the plate voltage, so the pentode has a high amplification factor. (As you know, the amplification factor or μ of a tube is the ratio of the plate voltage change to the grid voltage change that produces the same plate current change.) This means that to obtain the same a.c. plate voltage (μe_G) and hence the same a.c. power, the grid signal voltage required by a pentode is much smaller than that required by a triode power output tube. Thus, the *power sensitivity* of a pentode is much higher than that of a triode.

► The screen grid gives us the desired high sensitivity, but the presence of this second positive element causes a trouble that requires the presence of the suppressor grid.

The screen grid attracts electrons and speeds them on their way to the plate (in fact, it is sometimes called an accelerating grid). When these high-speed electrons strike the plate, other electrons are knocked out of the plate material. This emission of electrons due to bombardment is known as *secondary emission*.

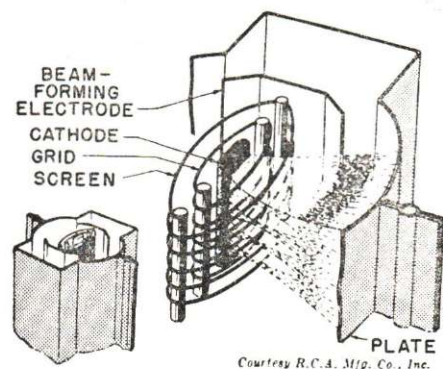

FIG. 15. The internal construction of the beam power output tube.

As long as the plate is more positive than the screen grid, these secondary emission electrons are attracted right back, so no harm results. However, the voltage developed across the plate load varies with the signal, and, of course, this drop will at times be so large that the plate voltage (supply minus load voltage) falls below the screen grid value. Whenever this occurs, the secondary emission electrons tend to move from the plate to the more positive screen grid. This reversal of electron flow will reduce the plate current, causing distortion.

Secondary emission is not prevented by the suppressor grid, but its bad effects are removed. This grid, tied to the cathode, is always at the cathode potential. It is therefore always negative with respect to the plate, and repels any electrons that try to move away from the plate, driving them back. Only the slower-moving secondary emission electrons are controlled by the suppressor grid; the high-speed electrons moving from the electron cloud fly past this grid so fast that its potential cannot block them.

Beam Power Tubes. The beam power tube is practically a pentode tube. However, instead of a suppressor grid, it uses a pair of beam-forming electrodes to get the same effect. Fig. 15 shows a cut-away view of such a tube.

The beam-forming electrodes are connected to the cathode, so they are negative with respect to the plate. They repel electrons, forcing the electrons to "bunch together" and pass through the openings between these electrodes to reach the plate. Thus, they force the electrons to form two streams or "beams." This concentrates the flow of electrons in a stream, actually producing a compact mass of them between the plate and the screen grid. There-

fore, any secondary emission electrons trying to move from the plate toward the screen grid are met at once by a large body of negative electrons (practically an electron cloud between the plate and the screen grid) that forces them back to the plate.

resistance of the 6K6G is about 50,000 ohms). Notice, too, that increasing the load resistance does not improve the shape of the characteristic. In fact, the opposite occurs; an increased load resistance increases the curvature at the right end of the dynamic curve.

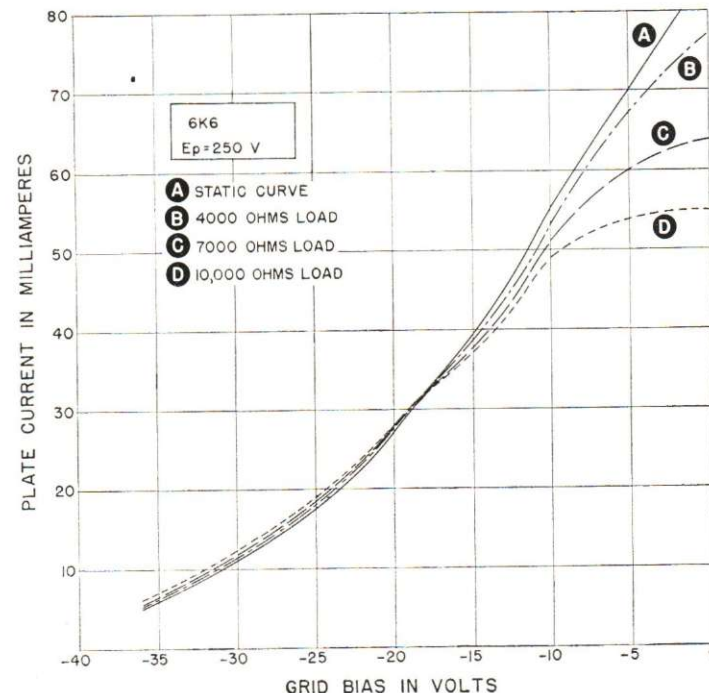

FIG. 16. These curves are typical of the static and dynamic curves of pentode power output tubes. Notice the upper bend curvature increases with load increases. Hence, the load must be kept low to keep down the third-harmonic distortion.

PENTODE AND BEAM POWER DYNAMIC CHARACTERISTICS

The dynamic characteristics of pentode and beam power tubes are not as linear as are those of a triode. Fig. 16 shows the static curve for a typical pentode output power tube and also the dynamic curves for several load values.

Notice that the load values given in Fig. 16 are far below the plate resistance for the tube (the a.c. plate

This undesirable drop-off in the curve occurs because the plate voltage falls below a critical value. That is, the plate current of a pentode or beam power tube is relatively independent of the plate voltage until the load voltage drop causes the plate-cathode voltage to fall about 75 volts. Further reduction of the plate voltage causes the plate current to drop, too. Therefore, the plate current follows the grid voltage changes only up to this point where the plate voltage "takes over."

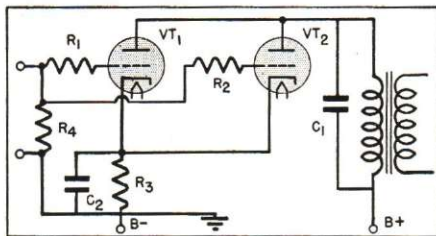

FIG. 17. Parallel output tubes were once commonly used to get an increased power output. However, the parallel arrangement is not ideal; it is subject to oscillation whenever the two tubes are not EXACTLY alike in their characteristics. (Aging will change them even if they were alike when new.) The feedback occurs through the grid-plate capacity of the tubes; to absorb this power, resistors R_1 and R_2 are sometimes added in series with the grids of the tubes as shown. These resistors do not have any current flow through them unless there is feedback current through the tubes. Any such feedback current must flow through the resistors, causing a loss of feedback energy. Sometimes resistors are necessary in the plate circuits as well, to prevent oscillation in the higher powered circuits.

The curves shown in Fig. 16 indicate that increasing the load does not remove all the second harmonic distortion, and actually increases the third harmonic distortion. (As you learned in an earlier lesson, second harmonics are added by operation over a single curvature, and third harmonics result if there is a double curvature in the tube characteristic.) Since third harmonic distortion is very distressing to the human ear, it is impossible to use a load value anywhere near the plate resistance value for this tube. Actually, the recommended load value is usually about one-seventh to one-ninth the plate resistance value for pentodes and beam power tubes.

The 6K6G tube, used with the recommended load value of 7600 ohms, will give us considerable power output, but the output will have a fairly high harmonic content when compared to that of a triode. Thus, a pentode will give us a greater power sensitivity and greater efficiency than a triode,

but only at a cost of increased distortion.

Beam power tubes are not quite as bad in this respect as are pentodes, but the triode can still give far better fidelity than either. However, the great power sensitivity of the pentode and beam tubes has made them widely used, and some of the limitations on their fidelity have been removed by a special circuit known as inverse feedback. We'll study this later in the Lesson.

PREVENTING OSCILLATION

You may have wondered at the use of C_3 in Fig. 14. In most circuits we try to *avoid* plate-to-cathode capacity, since it reduces the high-frequency response. However, particularly in power stages using pentode and beam power tubes, C_3 is necessary to prevent oscillation.

The power output stage has rather high load voltages, so even a small percentage of feedback to the grid circuit may supply enough power to allow the stage to oscillate. Furthermore, the leakage inductance of the output transformer makes the plate load inductive. This means the load voltage is in the proper phase to cause oscillation if it is fed back to the grid circuit.

The frequency of the oscillation may be well above the audible range because resonant circuits are formed by the long leads and the stray capacities in the stage. However, regardless of the frequency of oscillation, the circuit will be blocked and signals cannot pass. C_3 is an effective by-pass at these high frequencies and reduces the feedback enough to prevent oscillations.

Since the larger the capacity of C_3 is, the more it will by-pass the higher audio frequencies, the smallest value that will adequately prevent oscillation

is used. Commonly used values range from .001 mfd. to .02 mfd.

Usually, the set is designed so that C_3 and the output transformer resonate near the high-frequency end of the pass band and thus prevent some of the drop-off at these frequencies.

In some receivers, C_3 may be connected directly across the primary of T_1 , or else its lower end may go to the chassis instead of to the cathode. These changes do not affect the results as long as C_2 and C_1 are effective.

PARALLEL OUTPUT TUBES

When more power output is needed than can be obtained from a single tube (and a more powerful tube is not available or is undesirable because of voltage requirements), more than one output tube must be used. One way in which two or more tubes can be used is to connect them in parallel, as shown in Fig. 17. The corresponding parts—plates, grids, and cathodes—of the two tubes are tied together.

Since the plate resistance of the two tubes in parallel is only half that of

one tube alone, the load used is likewise only half the value that would be used with a single tube. Both tubes furnish current, so the load current is doubled. The result is that the power output of this parallel arrangement is twice that of a single tube for the same applied signal voltage.*

However, the parallel output stage is unstable (oscillations occur easily), and the fidelity is no better than that of a single output tube. When another arrangement, known as the push-pull connection, was developed, the parallel circuit was abandoned for receivers. The push-pull circuit provides even more power from two tubes than does a parallel connection and gives better fidelity. We'll study this circuit next. ► Incidentally, to distinguish between the push-pull and other connections, any power stage using a *single* tube or *parallel* tubes is known as a *single-ended* stage. The *push-pull* stage is called a *double-ended* stage.

*The power is I^2R , so doubling the current would give four times the power, but halving the load resistance gives us a net of twice the output.

Push-Pull Power Stages

The maximum power output that can be usefully obtained from a tube depends on the amount of distortion permissible. The push-pull circuit is particularly desirable because it eliminates all even harmonics that result from amplitude distortion in this stage. Thus, it has far better fidelity than does the single-ended output stage. This leaves only the odd harmonics so the power output can be increased until the odd-harmonic distortion level becomes objectionable. In fact, it is possible with the push-pull circuit to

obtain considerably more than twice the undistorted power that a single tube could deliver.

Essentially, a push-pull circuit is one in which the grids of two tubes are fed out of phase, and the resulting plate currents are recombined so that any *even* (second, fourth, etc.) harmonics that are produced by distortion in the stage are cancelled. (It is important to realize that any harmonics that are part of the signal will pass through the stage; it is only harmonics added within the stage that are can-

celled.) This circuit is used with triode, pentode, and beam power tubes; we'll take up each in order.

TRIODE PUSH-PULL STAGES

The basic triode push-pull circuit is shown in Fig. 18. Tubes VT_1 and VT_2 are identical types. The plate supply is fed through the center tap of transformer T_2 , so that the plate current of VT_1 flows through one half of the transformer while the plate current of VT_2 flows through the other half. Bias is obtained as a result of the flow of the combined plate currents through R_1 from B— to the cathodes.

The grid circuits are completed through the secondary of transformer T_1 to its center tap, where the return circuit goes through ground to R_1 .

► Notice the direction of the electron flow in each plate circuit, as indicated by i_1 and i_2 . In each tube, electrons move from cathode to plate. Therefore, the two d.c. plate currents flow in *opposite directions* through halves of transformer T_2 . Assuming we have identical tubes with the same bias and no signal, these plate currents are practically equal. Therefore, since the plate currents are equal in value, and flow in opposite directions through T_2 , the fluxes produced by these *d.c. currents* cancel each other, and no resulting flux exists in the transformer core when there is no signal. (When current flows one way through a transformer, the flux lines in the core have a particular direction. When the current is reversed, the flux direction reverses. Therefore, if *equal* currents flow through equal windings in opposite directions, the two fluxes cancel each other.)

Tracing The Signal. Now let's assume that a sine-wave signal e is applied to the primary of transformer T_1 in Fig. 18. A larger voltage will ex-

ist across the secondary, since this is a step-up transformer.

The induced voltage exists across the entire secondary winding of T_1 . Therefore, when terminal 1 of the secondary of T_1 is positive, terminal 3 must be negative, and vice versa.

► For the moment, let's assume that terminal 1 is positive. Then, the voltage e_1 between terminals 1 and 2 is that applied to VT_1 . This is half the total voltage, and at the moment, the grid end of the winding is positive. Therefore, at this instant, the positive signal voltage makes the grid of VT_1 less negative (it subtracts from the bias voltage), so the plate current of VT_1 increases.

At the same instant, terminal 3 is negative with respect to terminal 1. In fact, it is the most negative point on the winding, so the voltage e_2 (between 2 and 3) is negative. This signal voltage adds to the bias, making the grid of VT_2 more negative, so this tube's plate current decreases. Thus, you can see that the two grids are fed signals that are 180° out of phase, because when one is positive the other is negative.

Since on this half-cycle the current

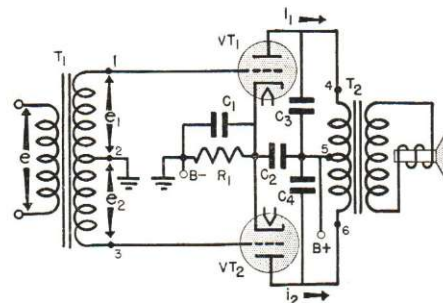

FIG. 18. A typical triode push-pull stage. In some cases you may find that by-pass condensers C_1 , C_3 , and C_4 may not be used in push-pull stages of this type. Condenser C_1 is not required if the tubes are balanced (as you will see when you study inverse feedback), and C_3 and C_4 are needed more with beam power tubes than with triodes.

i_1 of tube VT_1 is increased, and at the same time the current i_2 of VT_2 is decreased, we get an important action in the transformer T_2 . This changing plate current has an a.c. component, so an a.c. voltage is produced across the primary of T_2 . Let us say that terminal 4 is becoming more positive than 5, while 6 is becoming more negative than 5. Hence, terminals 4 and 6

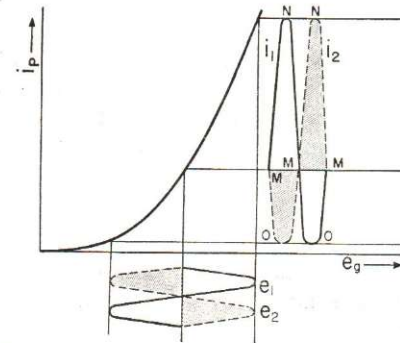

FIG. 19. When the operating point is on the lower bend of the tube's characteristic, the plate current pulses i_1 and i_2 will be distorted.

are opposite in polarity. *Insofar as the entire primary is concerned, therefore, the two voltages add together and act like a single a.c. voltage of twice the value of either component.* Also, the resulting a.c. current in the primary causes an a.c. flux in the core, which in turn induces a voltage in the secondary of T_2 .

► In the next half-cycle the polarities of e_1 and e_2 are interchanged (but they stay 180° out of phase) so the two actions reverse: current i_1 now decreases and i_2 increases. This reverses the phase of the a.c. voltage across the primary of T_2 and so reverses the direction of the flux in the core.

Since the a.c. voltage across the primary of T_2 is produced by *two* tubes, it is twice the value produced by one tube; in other words, we have double the power output of a single tube.

However, it is possible to get more from this stage, because distortion is reduced to the point that a greater output is obtainable. Let's see how.

Distortion Cancellation. Let's again apply a sine-wave signal and operate near the lower bend of each tube's characteristic curve, as shown in Fig. 19. Considering first the grid signal e_1 shown by the solid-line curve, the corresponding plate current curve is i_1 —also shown by a solid curve. The plate-current wave shape is not equal in amplitude on the two sides of its zero axis—that is, the alternation $M-N$ is greater than the alternation $M-O$ —so we have added the second and other even harmonics to the original fundamental sine wave.

At the same moment the other tube is getting the grid voltage e_2 . Therefore, as shown by the dotted lines in Fig. 19, its plate current i_2 is distorted also on the $M-O$ alternation. However, since e_1 and e_2 are 180° out of phase, the plate current alternation of i_1 that is distorted occurs at the same moment as the portion of i_2 that is *not* distorted (and vice versa).

► Now let's examine the action occurring in T_2 when these plate currents flow in the primary. As shown in Figs. 19 and 20, the plate currents i_1 and i_2 are 180° out of phase. However, remember that they flow in *opposite directions* through the halves of the primary of T_2 . Therefore, if i_1 produces flux f_1 as shown in Fig. 20, then i_2 will produce the flux f_2 . In effect, the reversal of plate current direction through the primary has resulted in f_2 being "flipped over." And, as we explained earlier, the two fluxes add together as if they were produced by a single a.c. voltage across the entire primary winding. Hence, when f_1 and f_2 in Fig. 20 are added (thus, $A-B$ plus $C-D$ equals $E-F$), the resultant flux

f_c is NOT AS DISTORTED as are f_1 and f_2 . The second-harmonic distortion present in the plate currents has been eliminated by the action of the fluxes in T_2 .

► Also, the same cancellation will occur on any other even harmonic, so no even-harmonic distortion of any consequence is produced in a push-pull stage. (IMPORTANT: Harmonics in

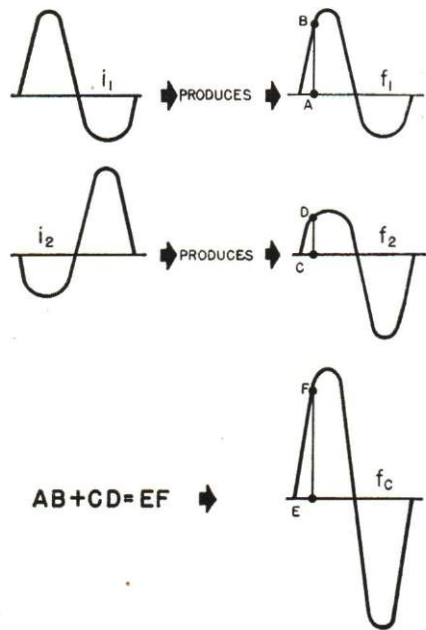

FIG. 20. The even-harmonic distortion cancellation occurs because of the manner in which the fluxes add in the output transformer.

the original signal are not cancelled, because they act like any original signal applied to the push-pull stage. This action occurs only for harmonics added by the push-pull tubes.)

Third Harmonics. Third harmonics are not cancelled, because odd-harmonic distortion affects both halves of the flux cycle, and adding the two flux components would not remove the distortion. This is shown in Fig. 21. Flux f_1 has a square-top shape (indicating odd harmonics have been added), and

f_2 has exactly the same shape. Adding the two together reinforces the odd harmonics instead of producing cancellation. The resultant f_c thus is just an enlarged version of its two components and contains just as many third harmonics (or other odd harmonics).

Summary. We can then say about push-pull circuits:

1. The d.c. plate currents are equal and opposite, so the d.c. fluxes in T_2 cancel.
2. The a.c. plate currents are 180° out of phase, but since the currents flow in opposite directions through T_2 , the fluxes add in the core of the transformer.
3. If even harmonics are added by amplitude distortion in the push-pull stage, they are wiped out when the fluxes are added in the output transformer.
4. If odd-harmonic distortion occurs in a push-pull stage, no cancellation exists—odd harmonics go through the

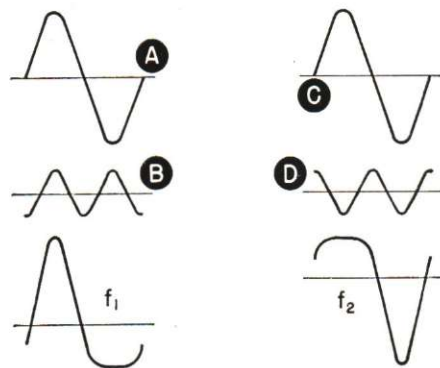

Perhaps the second-harmonic cancellation can be seen easier by considering the components of the fluxes. Flux f_1 is the result of adding a fundamental A to a second harmonic B that is 90° out of phase with it. Similarly, f_2 is the result of combining the fundamental C with the 90° out-of-phase second harmonic D. With f_1 and f_2 in the relationships shown, you can see that the fundamentals A and C are in phase and can be added directly. However, the second harmonics B and D are 180° out of phase with each other, so they cancel each other.

circuit in the same way as the fundamental wave.

► These facts are true whether the even and odd harmonics are the second and third or are the sixth and seventh—all even harmonics are eliminated, and odd harmonics are passed on.

Triode tubes have considerably more even-harmonic distortion than

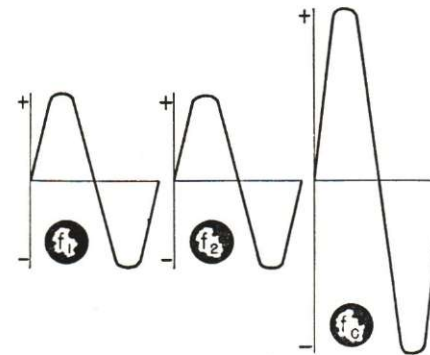

FIG. 21. Odd-harmonic distortion is not cancelled in push-pull circuits because both halves of the flux cycle are distorted, so when they are added, the combination must have the same distortion.

odd-harmonic distortion. Therefore, the push-pull circuit arrangement with triode tubes in a class A amplifier comes very close to the ideal in giving distortionless output.

Increasing the Output. The elimination of even-harmonic distortion in a push-pull stage permits us to get an undistorted output from the stage, that is more than twice as large as the undistorted output a single tube can give. We can get this greater output by doing two things:

1. We can make the load more nearly equal to the plate resistance.
2. We can adjust the bias so that the operating point is nearer the lower curved section of the characteristic, thus permitting a larger grid signal voltage, which in turn means a greater plate-current swing and more a.c. power.

Of course we could take both these steps with a single-tube amplifier, but doing so would increase the even-harmonic distortion in the amplifier. Such increased distortion also occurs in the push-pull stage, but the action of the stage promptly wipes it out; as a result, we get increased power without increased even-harmonic distortion. We can get about 2.5 times as much output power from a push-pull stage as from a single-ended stage before odd-harmonic distortion begins to become objectionable.

PENTODE AND BEAM POWER PUSH-PULL STAGES

Pentode and beam power tubes are used in push-pull arrangements in the same way that the triode is. As shown in Fig. 22, the only difference is the substitution of a pentode (or a beam

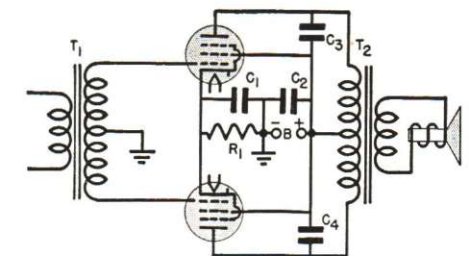

FIG. 22. A pentode push-pull power output stage.

power) tube in place of each triode. The operation of the stage is essentially the same.

However, pentode and beam power tubes have greater amounts of distortion, particularly third-harmonic distortion. Therefore, with push-pull stages using these tubes, it is common practice to use a low-resistance load.

As was shown for the 6K6G tube in Fig. 16, a small load causes less odd-harmonic distortion because it causes less of a bend in the dynamic curve

at the right-hand end. Such a load may cause more bend in the lower part of the characteristic, and thus cause more even-harmonic distortion—but we don't care; the even-harmonic distortion is eliminated by the push-pull arrangement.

In practice, a load resistance value is chosen to give all the power possible at the permissible value of odd-harmonic distortion. If, say, 5% third harmonic is permissible, the load resistance value is increased (thus increasing the power output) until the third-harmonic distortion reaches this value.

CLASS B PUSH-PULL STAGES

The circuits we have just discussed have been adjusted for class A operation. The operating point is chosen so that the grid will never be swung positive, nor will the plate current ever be zero.

However, where high power and high efficiency are required, a *push-pull* circuit can be operated as a class B amplifier (that is, operated with a bias set at the plate current cut-off point) without creating excessive distortion. As Fig. 23 shows, operating the tubes with the bias at the cut-off point causes the plate currents to be half-wave pulses. Then (Fig. 24) the flux produced by the other will fill in the spaces. The combination produces the complete a.c. flux cycle f_c . In other words, one tube works on one half-cycle, and the other tube works on the other half-cycle in the class B push-pull stage.

The class B stage has an increased efficiency because each tube operates for only half of each cycle and passes practically no current the other half-cycle. Thus, there is no steady d.c. plate current to cause a constant power loss in the plate resistance of the tube.

This is important because the amount of power that can be delivered from a stage depends on the ability of the tube to dissipate the heat developed within it. Thus, if a tube can dissipate 5 watts safely, we can increase the output only to the point where this power is lost in the plate resistance. Therefore, if we reduce the loss, we can safely increase the grid signal voltage to where the same loss occurs.

This is exactly what happens in a class B stage. Reducing the average plate power by causing the plate current to exist for only half the time permits the grid signal level to be increased (the grid can even go slightly positive). In turn, this produces high plate current pulses, so a large amount of a.c. power is delivered to the load. Since operation requires a specially designed voltage amplifier, the entire system must be designed for it. Fur-

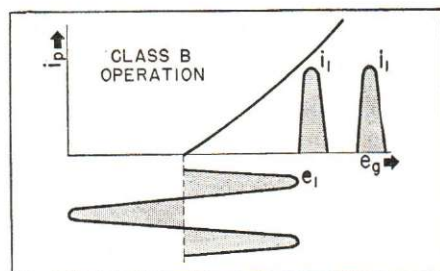

FIG. 23. Class B operation is at the plate current cut-off point, so the plate current pulses exist for half cycles.

thermore, class B operation in the low-frequency amplifier is possible ONLY in a push-pull circuit—otherwise half the signal would be destroyed.

► On paper, a class B stage looks much like a class A push-pull circuit. However, a fixed bias from the power supply is always used instead of self-bias, unless special zero-bias class B tubes are used. (Some class A stages use fixed bias also.) With a fixed bias

instead of R_1 , Fig. 22 could be a class B stage, providing the following parts differences are considered:

Transformer T_1 will be a step-down transformer, so its secondary will have low reactance. This is necessary because the grid is driven positive part of the time in class B operation, causing a grid current flow. If the trans-

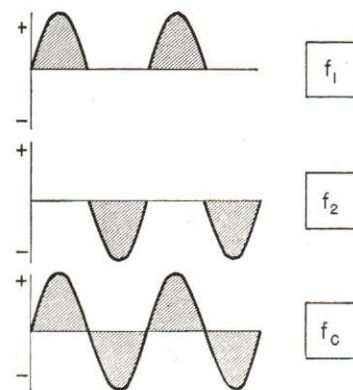

FIG. 24. As shown here, class B push-pull operation causes the tubes to supply current pulses alternately. The corresponding fluxes add to reproduce the entire a.c. cycle.

former had high reactance, the grid current flow through it would cause a voltage drop in the transformer, that would distort the peaks of the applied signal. Since the grids draw current, the grid circuit requires power—it is not just voltage-driven. Therefore, the

preceding stage must be capable of furnishing this power, and the transformer T_1 must be an impedance-matching type. A low-power tube (in a class A circuit) is frequently used ahead of a class B amplifier. This tube is known as the "driver" tube, because it *drives* the class B stage to its normal operating point.

The class B amplifier delivers more power than is usually necessary in a home receiver. For this reason, true class B amplification is rarely found except in public address systems or in other applications requiring high power. However, class AB operation, in between class A and class B amplification, is found in many of the more powerful home receivers.

AB OPERATION

Class AB operation uses a C bias somewhere in between the cut-off bias of class B operation and normal class A bias. Then, if the driving voltage is limited so that the grid never becomes positive, the operation is known as class AB₁. On the other hand, if the signal voltage applied to the grid is permitted to go slightly positive (approaching class B operation) the operation is known as class AB₂. Class AB₂ operation delivers higher power than AB₁ but less power than does class B.

Inverse Feedback

The output of any amplifier using pentode or beam power tubes contains a considerable percentage of distortion. One effective method of reducing this distortion (and also reducing any excessive hum, oscillation, or noise) uses the principle of inverse feedback.

Feedback, as the name implies,

means feeding part of the output voltage of an amplifier back into its input circuit. If the feedback voltage arrives at the input exactly in phase with the original input voltage, we have positive feedback, often called *regeneration*. If positive feedback is carried far enough in an amplifier, the amplifier becomes

unstable and finally oscillates.

For *inverse feedback* or *degeneration*, the phase relation between input and feedback voltages is such that the feedback voltage is made to arrive 180° out of phase with the input signal. This means that whenever the input signal rises in a *positive* direction, the feedback voltage rises in a *negative* direction, and vice versa. The feedback voltage, therefore, always opposes the original input signal. The resultant input is the difference between the two voltages, so it is always smaller than the original signal.

Since inverse feedback *reduces* the effect of the original input voltage, it reduces the output also. This amounts to a reduction in the amplifier gain. (An important point to remember is that unlike positive feedback, which makes an amplifier unstable and sometimes causes oscillation, inverse feedback drops the gain and output, making the amplifier entirely stable and always under control.)

So far, the only result of inverse feedback we have seen is a reduction in gain. Let us see what benefits this sacrifice may offer.

REDUCTION OF DISTORTION

Let us examine the circuit in Fig. 25. Except for the inverse feedback connections, it is a conventional single-ended power amplifier. Note that the lower end of input transformer T_1 is not returned to ground, but is connected to voltage divider R_1 - R_2 across the secondary of output transformer T_2 . (Resistors R_1 and R_2 are large in value compared to the impedance of the loudspeaker voice coil, so they absorb very little power from the circuit.) With this arrangement, part of the output voltage is fed back into the grid circuit; the exact amount of voltage can be regulated by adjusting the

values of resistors R_1 and R_2 .

Now, what happens when an input signal is applied to the circuit? First, the input signal e_1 produces in the secondary of T_1 the grid voltage e_2 , which after amplification appears in the output as e_0 . For simplicity, let us assume that although e_2 is a pure sine-wave input voltage as in Fig. 26A, the output e_0 looks something like that in Fig. 26B. The "bump" on the output wave may represent noise, distortion, or hum (or all three) generated in the amplifier tube. The bump thus represents something that should be eliminated, because it was not present in the original signal.

Through our feedback circuit, a portion (e_3) of the distorted output e_0 is fed back to the grid in series with e_2 . This e_3 voltage is indicated by the dotted curves in Figs. 26B and 26C.

For our purpose, we can assume that all these things occur instantaneously;

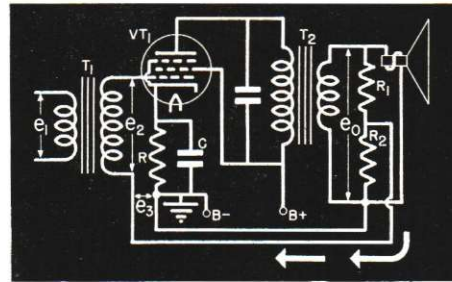

FIG. 25. A typical single-ended power output stage utilizing inverse feedback. The portion of the output voltage across R_2 is fed back as e_3 into the grid circuit.

that is, there is no delay between the time e_2 is applied to the grid, and the instant that e_3 is fed back into the grid circuit.

Suppose we have connected the windings of output transformer T_2 so that feedback voltage e_3 arrives exactly 180° out of phase with input voltage e_2 , as shown in Fig. 26C. This

means we have inverse feedback. Since e_2 and e_3 are of opposite polarity, the resultant input is equal to their difference. This input is illustrated by the curve in Fig. 26D which is obtained by subtracting e_3 from e_2 in Fig. 26C.

The final output caused by the new reduced input will be something like that in Fig. 26E. It is apparent that

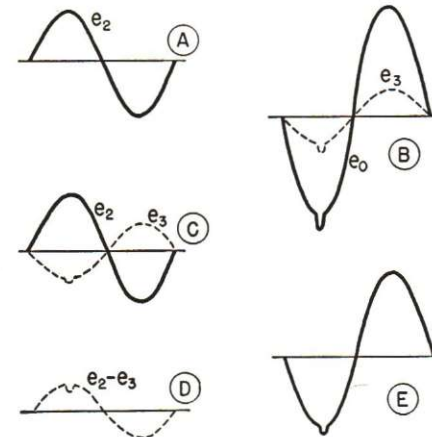

FIG. 26. These curves show how inverse feedback tends to correct amplitude distortion.

this is a much better reproduction of the original input than that obtained in Fig. 26B.

Through the use of inverse feedback we have taken the amplitude distortion components of the output and put them back into the input in such a direction that they tend to cancel themselves.

It is true that the output is reduced in amplitude in the process, because of the reduced effective input voltage (26D is smaller than 26A, so 26E is less than 26B,) but if the input signal voltage (e_1 in Fig. 25) is increased, the output can be brought back to its former level while the distortion components remain substantially reduced.

The amount of reduction of all distortion, hum, and noise by inverse feedback depends upon the amount of output voltage fed back to the grid cir-

cuit and upon the gain of the amplifier without feedback. In general, the gain of an amplifier and the distortion in its output caused by the amplifier itself are reduced by an equal per cent. This means that if feedback voltage is increased until the gain has been reduced 50%, distortion will be reduced 50% also. If the input voltage is then doubled to return the output to its former value, the distortion in the stage will also double, but it will still be only 50% of what it would be without feedback.

► Suppose we have an amplifier that without feedback, has the frequency-gain characteristic curve 1 in Fig. 27. Let us say the poor response below 100 cycles is caused by coupling condensers that are too low in capacity, the peak at 3000 cycles by resonance effects in a transformer, and the loss of frequencies above 10,000 cycles by the shunting effect of tube capacities. Obviously, an amplifier with such a response would not give high-fidelity reproduction.

Now let us see what improvements inverse feedback might make. With a medium amount of output voltage fed back into the input in proper phase, we get response curve 2 in Fig. 27. This is a considerable improvement. Observe that although the over-all gain has been reduced, the low-frequency and high-frequency response is nearer the response of the intermediate range,

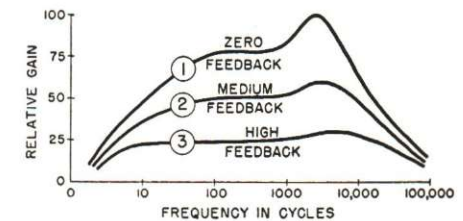

FIG. 27. Inverse feedback can also improve the frequency response, providing the gain can be sacrificed.

and the undesirable peak at 3000 cycles has been cut down.

How feedback brings this about may be visualized as follows: Below 100 cycles and above 10,000 cycles, where the amplifier's inherent gain is low, the output voltage also is low. This means the feedback voltage is small in magnitude, so the input is not reduced much. For the peak at 3000 cycles, however, the gain originally is high. The increased output voltage makes the feedback voltage quite large. When this is fed back, it cancels a large part of the original input and cuts the gain considerably. Therefore, the feedback corrects for frequency distortion as well as for amplitude distortion.

Even greater improvement in frequency response can be obtained if the value of the feedback voltage is increased, as in curve 3 of Fig. 27. Observe, however, that any increase in feedback is always accompanied by an additional reduction in gain. In-

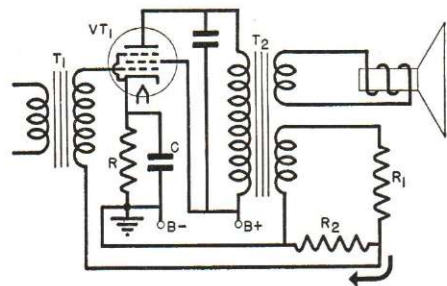

FIG. 28. Inverse feedback from a special winding on the output transformer.

verse feedback may be increased only to the point where it is impossible to get enough driving voltage (or where it becomes uneconomical to go further).

► The remarkable ability of inverse feedback to reduce distortion has resulted in its widespread use in modern receivers that use pentode and beam power tubes, particularly those using

single-ended stages. Let's study some of the typical circuits.

TYPICAL INVERSE FEEDBACK CIRCUITS

In addition to the basic circuit you have just studied, there are a number of variations on the method of getting the required feedback. It is generally

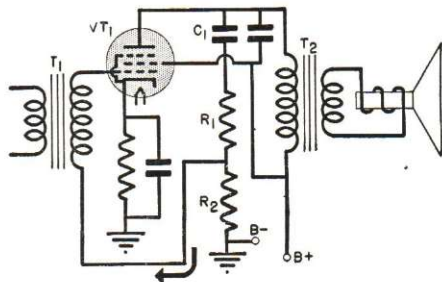

FIG. 29. Here the feedback is obtained from a voltage divider connected from plate to chassis.

unnecessary to feed back the entire output voltage to the grid circuit, and for this reason almost all feedback circuits use some form of voltage divider to reduce the feedback voltage. In the circuits shown in Figs. 28 to 32, the voltage divider resistors are marked R_1 and R_2 . The exact amount of feedback can be regulated by varying the resistance values.

► The output voltage developed across the average low-impedance loudspeaker voice coil (in a circuit like Fig. 25) does not always yield sufficient feedback voltage for satisfactory correction of distortion. However, an extra secondary winding having a greater number of turns can be added to the output transformer as in Fig. 28. This increases the feedback voltage with correspondingly better results.

► To get a high feedback voltage without an extra transformer winding, the voltage often is taken directly from

the plate of the tube (Fig. 29). Condenser C_1 serves only as a blocking condenser to prevent short-circuiting the d.c. plate supply and prevent application of the plate voltage to the grid. The capacity of C_1 should be high enough so that the reactance of the condenser is small compared to the resistance of R_1 and R_2 , otherwise the feedback will not be the same for all frequencies.

► The feedback voltage may be fed in parallel with the input instead of in series. This is usually done with resistance-coupled input circuits like that shown in Fig. 30. Note that R_2 is not only part of the feedback voltage divider circuit, but it is also the grid resistor for the tube. C_1 , as before, is only a blocking condenser.

► For feedback over two stages, the circuit in Fig. 31 is often used. Observe that the feedback voltage is inserted in the cathode circuit. The feedback could not be applied to the grid of the first tube because we have a phase

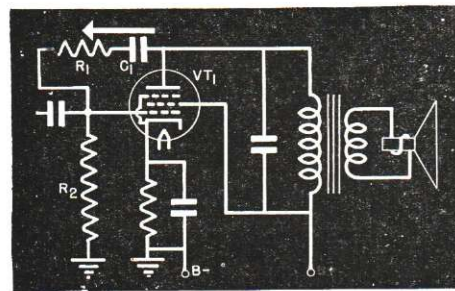

FIG. 30. The grid resistor R_2 divides the feedback voltage with R_1 .

shift of 180° in each tube, and with two tubes this makes a total shift between input and output of 360° . The voltage at the grid of the first tube, therefore, is exactly in phase with the output voltage, and coupling the feedback to the first grid would result in positive feedback.

► Feedback, however, can be applied to the grid of the first tube in a two-tube amplifier if an extra output transformer winding is used. Fig. 32 is an example of this. In this case, the connections to the extra transformer winding may be reversed, if necessary, for proper phasing. R_3 serves only to load the transformer winding, and has no direct effect on the feedback voltage.

Current Degeneration. All the preceding systems are known as volt-

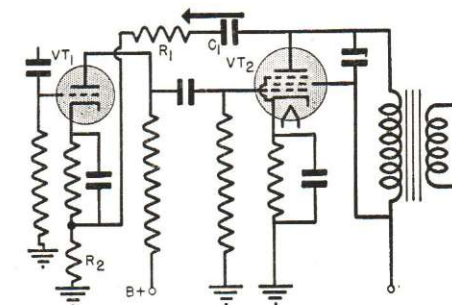

FIG. 31. Inverse feedback from the plate of the output tube to the cathode of a voltage amplifier.

age types, since it is the output voltage that is fed back. This system thus corrects the output voltage and hence reduces both frequency and amplitude distortion. There is another system which depends on the output tube plate current. This current type can correct for amplitude distortion but does not correct the frequency response.

A typical circuit is shown in Fig. 33. This is a conventional amplifier except that the bias resistor by-pass condenser has been omitted. With no condenser, the plate load consists of both the output transformer and the cathode resistor R_2 , and a small part of the output voltage is developed as e_3 across the cathode resistor. This voltage acts as a variable bias that opposes changes in the grid signal. When the grid voltage e_2 goes positive, the increase in plate current through R_2 increases the

bias (e_3) and tends to make the grid more negative. When the signal swings negative, the bias e_3 is reduced. Hence, it has the same effect as the inverse feedback circuits already described.

Since this circuit acts to minimize changes in *plate current*, it can correct amplitude changes but not the frequency response, because the *same*

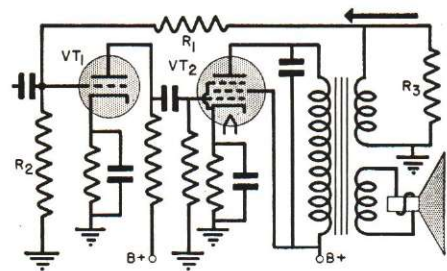

FIG. 32. Feedback from a special output transformer winding to the grid of a voltage amplifier.

plate current amplitude can cause differing output voltages if the load impedance changes with frequency.

FEEDBACK LIMITATIONS

It has been assumed that the feedback voltage is always 180° out of phase with the input voltage in these feedback circuits. Unfortunately, this is not always true. In addition to the 180° phase shift in each tube, there is always some phase shift in each coupling condenser or audio transformer. These extra phase shifts are quite small at medium audio frequencies, but at extremely high and extremely low frequencies they can become quite large. When more than two stages are

included in the feedback path, it is possible that the net change in phase could result in positive instead of negative feedback, causing oscillation. Therefore, the design of these circuits must be carefully worked out. (It is necessary that any defective parts in these circuits be replaced by exact duplicates to avoid possible trouble of this kind.)

► All the inverse feedback systems shown here can be applied to push-pull stages as well. Incidentally, the cathode type of Fig. 33 introduces no degeneration in a push-pull stage (when the same resistor biases both tubes) unless the tubes become unbalanced. If the two tubes are the same, when one

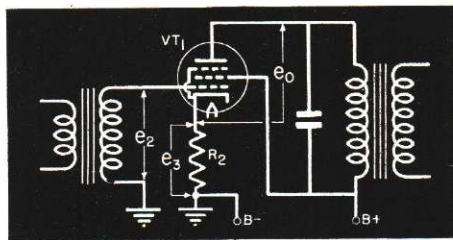

FIG. 33. Current degeneration is obtained when the cathode by-pass condenser is omitted. This will correct for amplitude distortion but not necessarily for frequency distortion.

plate current is increasing the other is decreasing, so the drop across the bias resistor is practically constant. Therefore, there will be no degeneration until the circuit is upset and needs it the most! For this reason, you will frequently find that the bias resistor for push-pull tubes is not by-passed.

Phase Inverters

In our study of push-pull amplifiers, you undoubtedly noticed the use of two transformers. This was the standard circuit at one time. Modern practice, however, is to eliminate audio transformers whenever possible, since high-quality ones are bulky and expensive, and cheaper ones do not give faithful frequency response.

We can't, of course, get rid of the impedance-matching *output* transformer. (Nor, in class AB_2 and class B operation, can we avoid using the input transformer, for no other device can perform its two functions of offering low impedance and of matching impedances to the driver.)

However, in class A and class AB_1 operation, the *input* push-pull transformer is an ordinary voltage amplifying transformer whose only special function is providing a way to feed the two grids 180° out of phase. It can be eliminated if we can find some other way of doing this.

As you know, a vacuum tube stage reverses the phase of a signal 180° because the signal voltage across the load is opposite in polarity to the signal applied to the grid of a tube. Therefore, if we feed the grid of one of the push-pull tubes from a voltage amplifier, and then put in another tube (called a *phase inverter*) to reverse the phase to feed the other push-pull tube, we can have push-pull operation (class A) without using an input transformer.

A resistance-coupled stage is used as the phase inverter. Its use offers several advantages: higher fidelity characteristics, a reduction of the possibility of magnetic coupling and hum pickup, and a reduction in weight of the equipment. In general, it is cheaper to use a tube stage than the relatively expensive input push-pull transformer.

Of course, in addition to reversing the phase, the additional stage must not feed a greater signal to its push-pull tube than is fed to the other. Therefore, it is necessary to limit the gain so that the inverter tube will not have greater output than the voltage amplifier.

► Fig. 34 shows a simplified diagram of an inverter. VT_1 is a voltage amplifying stage. It amplifies the signal, and feeds tube VT_2 through the resistance coupling $R_3-C_4-R_4-R_5$. A voltage di-

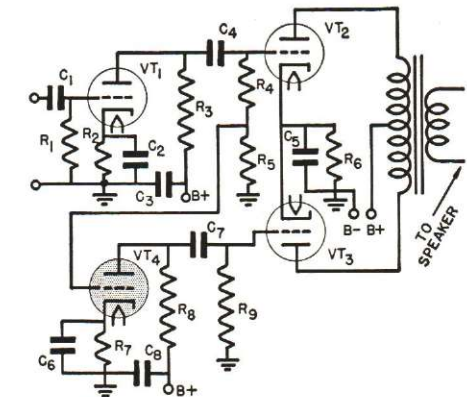

FIG. 34. A basic phase-inverter stage.

vider R_4-R_5 is used to feed a portion of the output voltage from VT_1 to the phase inverter tube VT_2 .

The tube VT_4 amplifies in the normal manner. However, the voltage divider R_4-R_5 is figured out so that if this stage has a gain of, say, 10, then only one-tenth of the voltage across the R_4-R_5 combination is fed to the tube. Hence, there is effectively no gain in the VT_4 stage (10 times $1/10$ is 1), and the voltage across R_9 is the same amount as the voltage across R_4-R_5 , so tube VT_3 gets the same amount of signal voltage as does tube VT_2 . (When servicing this type of phase inverter, it is important to replace R_4 and R_5 with

exact duplicate parts when these resistors are found defective. This is necessary so that the proper voltage division will be obtained to counteract the gain of VT_4 .)

What about the phase? When the signal in the grid circuit of VT_2 is going positive, this same signal is fed to the grid of VT_4 . The phase reversal of VT_4 causes the grid of VT_3 to be driven

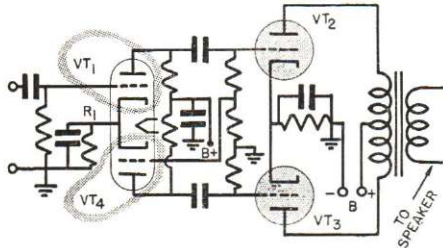

FIG. 35. The phase inverter and the driver are sections of the same dual tube.

negative at this same moment—just what we want to happen.

► Fig. 35 shows another arrangement using the circuit of Fig. 34. Tubes VT_1 and VT_4 are individual sections of a dual-triode tube. The same bias resistor (R_1) is used for both sections, a practice that tends to equalize any slight irregularities in the characteristics of VT_1 and VT_4 .

DEGENERATIVE PHASE INVERTERS

There is danger that aging of the tubes may upset the voltage balance between the outputs of VT_1 and VT_4 even when they are part of the same tube. If an unbalanced voltage is fed into the push-pull circuit, we will get a distorted output, as the even harmonics will not balance out.

One way around this is to use a single tube to feed both the push-pull tubes, as shown in Fig. 36.

First, let's examine the circuit of VT_1 . Tracing the direction of electron

flow from cathode to plate, we find that the end 3 of R_4 is negative with respect to terminal 4. Continuing around through the B supply, and through R_3 back toward the cathode, we find that terminal 2 of R_3 is negative with respect to terminal 1.

Now, let's consider terminal 4 of R_4 to be grounded through C_4 (insofar as a.c. signals are concerned), so that it connects effectively to terminal 2 of R_3 . Comparing the voltages across these two resistors, we find that an increase in plate current makes terminal 3 of R_4 more negative at the same instant that it makes terminal 1 of R_3 more positive. Therefore, if we feed VT_2 from terminal 3 of R_4 , and feed tube VT_3 from terminal 1 of R_3 , the two tubes will be fed out of phase. R_3 and R_4 must be equal in size, of course, so that the voltages fed the push-pull tubes will be equal.

► Since R_3 is part of the plate load, but is also in the input circuit in such

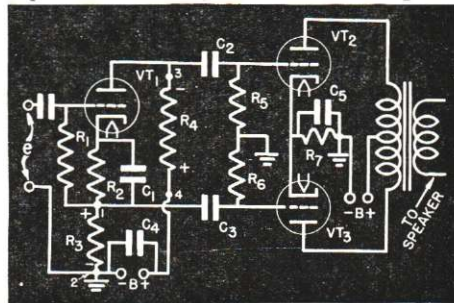

FIG. 36. Both push-pull tubes may be fed from a single tube in this unique phase inverter stage.

a way that the voltage developed across R_3 opposes the input signal voltage, this circuit is degenerative. For example, if the stage gain is 50, then 1 volt across R_1 (the grid resistor) will appear as 25 volts across R_4 and R_3 respectively. (25 plus 25 is 50, the a.c. voltage we would get from a gain of 50.) However, the 25 volts across R_3

must be subtracted from the voltage e applied at the input terminals, so to get 1 volt across R_1 , we must apply an e of 26 volts. Hence, the over-all gain of VT_1 is only about 2 ($50 \div 26$ is about 2). As only half the output voltage is supplied to each of the push-pull tubes, the effective gain is one, so the input voltage e we supply must be the same as the voltage necessary to drive the grid of one of the push-pull tubes.

As the tube VT_1 ages, the voltage across R_3 and R_4 will tend to decrease, but this lets a slightly increased amount of voltage appear across grid resistor R_1 , and conditions are restored approximately to normal. Furthermore, even if the input voltage increases to large amounts, the resulting increase in voltage across R_3 prevents overload. Thus, all the advantages of degeneration are added to this phase inverter stage.

► The same idea of degeneration is also used in what is called a self-bal-

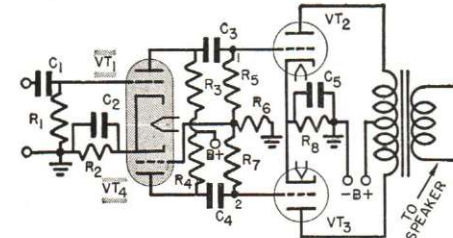

FIG. 37. By making a slight change in the grid feed circuit of the phase inverter stage, a balanced phase inverter, including degeneration, is obtained.

ancing inverter using two tubes. The circuit is shown in Fig. 37. At first glance, it appears to be the same as that of Fig. 35, but notice the position of resistor R_6 . This resistor is placed so that degeneration occurs, and its value is increased to equal that of R_5 (and R_7).

Half the voltage between point 1 and ground (point 1 is the grid terminal of VT_2) is applied to the grid

of VT_4 . The amplified plate voltage of VT_4 then appears between point 2 and ground; half of it is across R_6 , and is fed back into the grid circuit of VT_4 . Since (as in the circuit of Fig. 36) the output voltage is fed back to the grid of VT_4 , the effective gain is only 2 in-

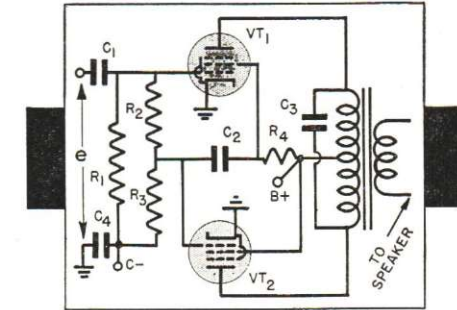

FIG. 38. A special phase inverter circuit used on certain Philco receivers. One of the output tubes is used as the source of the grid voltage for the other.

stead of being the natural gain of the stage (and, since VT_4 gets only half the R_5 - R_6 voltage, the gain from point 1 to point 2 is only one—the two voltages are equal). However, this gain is practically independent of the characteristics of tube VT_4 , so the tube can age without upsetting the circuit.

► A somewhat unique phase inverter circuit is shown in Fig. 38. This is used in certain Philco receivers.

Here, the input signal e is fed directly to the grid of one of the push-pull tubes (VT_1) through condenser C_1 . The grid resistor for this tube is R_1 . This tube amplifies the signal in the normal way.

Inserted in the screen grid circuit of tube VT_1 is a small resistor R_4 . This acts as a load resistor, in that a certain amount of the signal energy developed by VT_1 appears across this resistor. In other words, the screen grid acts like a triode plate, and taps off a certain amount of the signal energy, with resistor R_4 acting as its load. The

signal developed across R_4 is fed to the grid of VT_2 through C_2 . Resistor R_3 is the grid resistor for this tube.

Thus, the tube VT_1 serves a dual purpose. It is one of the tubes in the push-pull amplifier, and also acts as the phase inverter for tube VT_2 .

Considerable degeneration is necessary in this circuit to prevent distortion. This is furnished by resistor R_2 , which is a resistance of higher value than either R_1 or R_3 . Through it, some of the energy fed back through C_2 is applied to the grid of VT_1 , opposing the original signal and causing degeneration in this tube. In addition, some

of the input signal e is fed through R_2 to VT_2 so that it is out of phase with the C_2 voltage. Hence both tubes undergo a certain amount of degeneration. However, degeneration is not carried as far as in the phase inverters we previously described, because nearly normal performance is wanted from VT_1 . Just enough is used to give reasonable fidelity.

► There are a number of other less commonly used phase inverter circuits. However, they all work essentially like the basic ones we have just described, so you will have little trouble in understanding them.

Facts About Low-Frequency Amplifiers

This lesson is an important milestone in your Course. Here, you gain a complete understanding of one of the major kinds of amplifiers. This lesson might also be considered a summary of your previous studies—because you use facts from all the earlier lessons. You put together your knowledge of how condensers and tubes work, facts you have learned about basic amplifiers, your knowledge of sound waves and their characteristics, and your knowledge of the kinds of distortion. So many important facts are in this lesson that you should come back to it from time to time and quickly run through it to refresh your mind on important circuit and stage actions.

► As a summary of the highlights of this lesson, the following facts will be helpful. If any are not clear in your mind, then it is advisable for you to go back over the lesson right now, because you will need these important facts for later lessons.

The low-frequency amplifier deals with the intelligence signal—audio or

video. In sound receivers, the audio signal must be increased in power to operate the reproducer properly, so a power output stage is used. However, power stages require considerable voltage to drive them, so voltage amplifiers are used to increase the output of the demodulator so that it can operate the power output stage properly.

The voltage amplifiers are named according to the devices used to couple the stages together (or to couple to the power output stage). Hence, voltage amplifiers are known as resistance-capacitance-coupled, impedance-coupled, and transformer-coupled stages.

Of these, the resistance-capacitance-coupled stage offers low gain but is capable of the best fidelity characteristics. It is possible to get a frequency range wide enough to make frequency distortion of minor importance. Amplitude distortion can be kept within reasonable limits also, and phase distortion is of importance only in television. (You will learn more about trouble with phase distortion as you study

television receivers in detail.)

When the voltage amplifier has built up the voltage sufficiently, this voltage is used to drive a single-ended or a push-pull power output stage.

► In the single-ended power stage, a single power tube (or tubes in parallel) will be found. The triode offers the best fidelity, but it requires a much higher signal voltage. For this reason, most modern receivers use pentode or beam power tubes. Both the pentode and the beam power tubes have higher power sensitivity than the triode (they require a much smaller grid signal voltage). For example, earlier radio receivers used two or sometimes three voltage-amplifier stages to drive a single triode power output stage. With modern receiver design, a somewhat greater output is obtainable from the demodulator, so it is possible for a single voltage-amplifier stage to give enough voltage to drive pentode or beam power stages.

You may wonder why both pentode and beam power tubes are used when they seem so similar. The beam power tube is somewhat more efficient than the pentode, and does not introduce quite as much third-harmonic distortion because its characteristic curve is shaped in a slightly different way. The pentode tube was introduced first, and is still used for low-power outputs. However, the more efficient beam power tube has replaced the pentode in the majority of receivers.

In power output stages, the high frequencies may be cut down somewhat by the necessity for a by-pass condenser across the plate load, and the low-frequency response depends upon the primary inductance of the output transformer. Even so, it is possible to make the frequency response of these stages fairly good.

However, the pentode and the beam

power tubes introduce considerable *amplitude* distortion. In the single-ended stage, much of the amplitude distortion can be corrected by inverse feedback, and the push-pull output stage has the important advantage of eliminating all even-harmonic distortion that originates in the output stage. Inverse feedback can be used for push-pull stages also, and will cut down the odd-harmonic distortion.

► In order for a push-pull stage to function properly, the grids of the two tubes must be fed 180° out of phase. This requires a special input transformer or a phase inverter tube stage. The input transformer has been practically eliminated from modern receivers because of its undesirable characteristics and rather high cost. Instead, a phase inverter is almost universally used to feed the grid of one of the push-pull tubes.

The two push-pull tubes must be fed with input voltages of the same amplitude. When a phase inverter stage is used, one of the push-pull tubes is fed directly from a voltage amplifier stage. A fraction of the output of this stage is also fed to the phase inverter stage. There this fractional voltage is amplified and inverted in phase; then it is fed to the other push-pull tube. The amplification received in the phase inverter stage is just enough to make the two push-pull grid voltages equal. (A single tube may feed both push-pull tubes if its load is split between its plate and cathode circuits so that phase inversion occurs.)

► Inverse feedback is a system in which part of the output energy is fed back to some point in an amplifier where it will be out of phase. Any distortion or other unwanted component that originates between these points (the output and the point where the feedback is returned) will be fed back

out of phase and thus will tend to cancel itself. Therefore, inverse feedback is particularly used with pentode and beam power tubes to correct their amplitude distortion. Of course, inverse feedback lowers the gain of the stage or stages within the feedback path, so a higher input voltage must be supplied at the input terminals. For this reason, inverse feedback is usually limited to the power output stage and perhaps to one preceding stage. Another voltage amplifying stage must be used ahead of the inverse-feedback circuit to deliver the required input voltage. Naturally, amplitude distortion must be controlled in this voltage amplifier.

The results of inverse feedback are such that a beam power output stage utilizing this circuit can deliver practically the same quality of output as the triode tube and still require somewhat less input voltage than would a triode tube giving the same power output.

► In modern radio receivers, you will recall that there are many kinds of power supplies. Some receivers operate from the power line and use a power transformer. It is almost universal to find a push-pull stage in such sets when they are intended to give good fidelity. On the other hand, if the receiver is an a.c.-d.c. type or is battery operated, there is a limit to the amount of voltage and current available. For this reason, such sets commonly use single-ended power output stages and smaller loudspeakers, which require less power.

In a television set, there may be from one to three voltage-amplifier stages. The television cathode ray tube—the tube on whose face the picture is reproduced—is the “output” stage in a television set. This tube is entirely voltage driven—very little power is needed to modulate the electron stream

within it. Therefore, in a television set, the low frequency (or video) amplifier consists primarily of voltage amplifying stages.

► As a radio serviceman, you are interested in all these stages because the parts are subject to natural breakdowns—condensers open, short-circuit, or change in value; resistors open or burn out; transformers short-circuit and open-circuit; and tubes change their characteristics with age. You need to know just how these amplifiers operate so that you can intelligently choose the proper replacement part.

Of course, when you have the manufacturer's instructions, or the part values are marked, you need only use parts like the originals to get the same results. However, there will be plenty of instances in which you will have to make a replacement and will not know the exact values of parts. Then you can be guided by your knowledge of what will happen if you use a resistor or a condenser that is larger or smaller than the original. Also, your knowledge of how standard circuits work will always be helpful when you meet non-standard circuits.

► You are now in a much better position to judge the fidelity that would be expected from different resistance-coupled amplifiers. However, always remember that some manufacturers make up for the deficiencies of one stage by purposely changing the response of another. Therefore, don't make the mistake of assuming that the response of the amplifier is necessarily poor because the design of one stage happens to sacrifice low frequencies or high frequencies. Another stage may have an excess response to these frequencies, so that the final result of the combination may be a relatively good output.

Lesson Questions

Be sure to number your Answer Sheet 15FR-2.

Place your Student Number on every Answer Sheet.

Send in your set of answers for this lesson immediately after you finish them, as instructed in the Study Schedule. This will give you the greatest possible benefit from our speedy personal grading service.

1. Does the low-frequency amplifier obtain its input signal directly from: 1, the demodulator; 2, the i.f. amplifier; or 3, the power supply?
2. If the low-frequency response of an R-C coupled amplifier is to be increased, should the capacity of the coupling condenser (C_3 in Fig. 1) be: 1, increased; or 2, decreased?
3. If a stage having a gain of 12 is cascaded with a stage having a gain of 10 what will be the total voltage amplification of the two?
12 x 10 = 120 V.
4. Will an increase in the ohmic value of the load resistance for a triode tube make the dynamic E_G - I_P curve for the tube straighter (more linear)?
LINEAR
5. With a triode tube, is the maximum undistorted power obtained when the plate load: 1, is equal to; 2, is one half of; or 3, is twice the plate resistance?
6. What is the purpose of the plate-to-cathode condenser (C_3 in Fig. 14) that is used in power output stages? *TO PREVENT OSCILLATION*
7. Does the push-pull stage eliminate: 1, even; or 2, odd harmonic distortion?
8. If there is no by-pass condenser across the bias resistor in the cathode circuit, is the inverse feedback: 1, the voltage type; or 2, the current type?
9. What is the purpose of the phase inverter stage?
TO CHANGE THE PHASE OF SIGNAL VOLTAGE 180° SO THAT PUSH-PULL CAN BE PROPERLY DRIVEN.
10. Why is it important to replace resistors R_4 and R_5 in Fig. 34 with exact duplicate parts?
TO OBTAIN PROPER VOLTAGE.



HOW TO START STUDYING

For some people, starting to study is just as hard as getting up in the morning. An alarm clock will work in both cases, so try setting the alarm for a definite study-starting time each day. Start studying promptly and definitely, without sharpening pencils, trimming fingernails or wasting time in other ways.

Beginning is for many people the hardest part of any job they tackle. So formidable does each task appear before starting, that they waste the day in dilly-dallying, in day-dreaming, and in wishing they didn't have to do it. The next day, and the next after that are the same story. Indecision brings its own delays, making it harder and harder to buckle down to work.

Are you in earnest? Then seize this very minute; begin what you can do or dream you can. Boldness in starting a new lesson is a great moral aid to mastery of that lesson; only begin, and your mind grows alert, eager to keep on working. Begin, and surprisingly soon you will be finished.

J. C. Smith