

**SPECIAL POWER SUPPLIES
FOR RADIO EQUIPMENT**

13FR-2



NATIONAL RADIO INSTITUTE

WASHINGTON, D. C.

ESTABLISHED 1914

STUDY SCHEDULE NO. 13

For each study step, read the assigned pages first at your usual speed. Reread slowly one or more times. Finish with one quick reading to fix the important facts firmly in your mind, then answer the Lesson Questions for that step. Study each other step in this same way.

- 1. **The Universal A. C.-D. C. Power Supply** Pages 1-8
The universal power supply is very commonly encountered, as it is used in most midget receivers. This supply has the advantage of small size and low cost. Also, it will operate from any 110-volt power line, whether a. c. or d. c. Special methods are used to obtain the needed operating voltages, even to the development of special tubes for such receivers. Answer Lesson Questions 1, 2, 3 and 4.
- 2. **Voltage Doublers** Pages 8-12
When voltages are needed which are higher than the universal supply can deliver but a power transformer is not wanted, a voltage doubler can be used. These circuits are able to step up the voltage as long as the current demand is low. Both the half-wave and full-wave types are found in some of the larger table model receivers and in other radio and electronic equipment. Voltage doublers will work only from an a. c. power line, as they depend on the phase reversal on alternate half cycles for operation. Answer Lesson Question 5.
- 3. **Vibrator Power Supplies** Pages 12-19
The vibrator made auto sets practical, and led to the development of other mobile equipment. This unit removed the requirement for bulky, expensive batteries or an expensive motor generator, by making it possible to obtain standard voltages from a single low-voltage battery which is already available in the car. Here you learn how the mechanical switch changes d. c. into a pulsating current which can be stepped up by a transformer and treated like a. c. A tube rectifier can be used, or another vibrator section can be made to convert the high-voltage a. c. to d. c. again. A vibrator power supply comes closest to duplicating the standard a. c. supply, in regard to the voltage and current output. Answer Lesson Question 6.
- 4. **Modern Battery Receivers** Pages 19-25
A truly portable receiver must run from a self-contained power supply. Batteries are ideal, particularly since modern low-drain tubes operate from small light-weight cells. These low-current tubes have also made it possible to obtain filament power from the ordinary universal power pack, as well as plate and grid voltages. Thus, by using a small a. c.-d. c. power supply as well as batteries, the three-way portable can be run from power lines when available, thus saving the batteries. Answer Lesson Questions 7, 8 and 9.
- 5. **Special Power Supplies** Pages 26-28
There are instances where a motor-generator unit is needed to furnish power for some piece of standard or special equipment. Also, you may be called on to convert from one power supply type to another, due to differences in available power or for some special operation. The methods are discussed here, so you can see just what is possible and the best way of getting the desired operation. Answer Lesson Question 10.
- 6. **Mail Your Answers for this Lesson to N. R. I. for Grading.**
- 7. **Start Studying the Next Lesson.**

SPECIAL POWER SUPPLIES FOR RADIO EQUIPMENT

The Universal A. C.-D. C. Power Supply

THE standard a.c. power supply you've studied so far uses a power transformer to step up the line voltage. The stepped-up voltage is then applied to a rectifier tube, which in turn feeds the load through a filter. This standard power supply is nearly always used when high voltages or large currents are needed.

► But sometimes it is impossible or undesirable to use a transformer in the power supply. In some sections of our largest cities, for example, the power lines furnish d.c. instead of a.c. Of course, a transformer can't work on d.c.

Then, too, some places have 25-cycle current instead of the usual 60-cycle. This requires a special, more expensive transformer.

There are also cases where a power transformer is unnecessary—modern midget receivers, for example. These sets will operate reasonably well on just the line voltage. Further, they are so small that there is no room in them for a bulky transformer. And finally, they are built to sell at very low cost—which is possible only if the expense of a power transformer is eliminated.

► Now we are going to study a universal a.c.-d.c. power supply which contains no power transformer. It is designed to operate from any a.c. or d.c. power line, and is entirely satisfactory for small sets and low-power apparatus. Let's first see how the B and C supplies are obtained, then go into the question of filament supply a little farther on.

The B-C Power Pack

A simple universal power supply is shown in Fig. 1. As you see, no power transformer is used—the power line connects directly to the circuit. The half-wave rectifier tube *VT* is followed by a standard condenser input filter which connects to the load.

This circuit works just like the standard half-wave rectifier with a condenser-input filter that you've already studied. That is, when the source voltage makes point 2 positive with respect to point 1, the tube conducts; electrons flow from point 1 through load R_L , and C_1 is charged to the polarity shown. When the voltage reverses, making point 1 positive with respect to point 2, the tube no longer

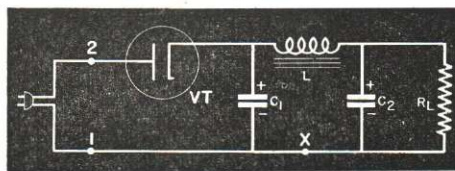

FIG. 1. This universal power supply uses no power transformer.

conducts; C_1 partially discharges through load R_L , maintaining an electron flow through it. Thus, the only difference between this circuit and the standard half-wave rectifier circuit is that we've managed to eliminate the power transformer. (Remember, the circuit is completed between points 1 and 2 by the power line leading to a generator.)

Of course, the maximum possible voltage across the load in this circuit is the peak value of the power line

voltage. As most power lines deliver about 115 volts,* the peak value will be about 165 volts. Actually, when current is taken from the power pack, the drop in the tube usually brings the total voltage across the load down to about 100 volts. Obviously, from what you know about filters, a condenser-input filter is necessary in a universal receiver to get a higher-output voltage than would be delivered by a choke-input filter.

► As in the standard power supply, the choke coil in Fig. 1 can be placed at point X (between the negative leads of the filter condensers), and the voltage drop across it can then be used to furnish bias voltages.

Circuit Variations. Many receivers use dynamic loudspeakers, which have a field coil that must be energized by d.c. from the power sup-

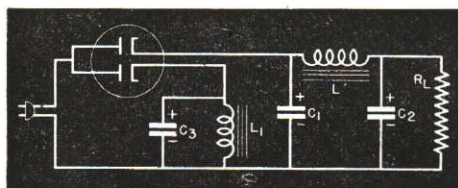

FIG. 2. The speaker field is energized from a separate diode here.

ply, in order for the speaker to operate. If the coil has a low resistance (500 ohms or less), we can use it in place of the filter choke in Fig. 1 and thus make the coil do double duty.

► But most speakers used in a.c.-d.c. sets have a field coil resistance of around 2500 ohms. A coil with such high resistance can't be used as a filter choke in our universal circuit,

* Standard power lines are rated at 110 volts, 115 volts or 117 volts. Actually, these ratings mean the same kind of power line, as the power line voltage may be any value between 100 volts and 120 volts, depending on the load on the line. The peak value is about 1.4 times the r.m.s. value for which the line is rated.

because there would be too much d.c. voltage dropped across it, and therefore too little output from the filter. When we use such a speaker, we have to put a regular choke in our filter section, and find some other way of connecting the speaker coil to the power supply to give the coil the current it needs.

A circuit which does this is shown in Fig. 2. Here, a dual diode tube is employed. (Separate diodes could be used, if desired.) One diode is used as a half-wave rectifier for the load R_L ; the other acts as a rectifier to supply the speaker field, marked L_1 , which acts as the load for this tube section. The filter condenser C_3 provides sufficient filtering for the field. The other filter C_1-L-C_2 is a standard condenser-input filter, used to deliver pure d.c. to the load R_L .

► As you know, the input filter condenser draws a rather high current from the rectifier tube until the condenser is fully charged. As a result, in the circuit shown in Fig. 2, each of the rectifier tube sections undergoes considerable strain when the circuit is first turned on. Fig. 3 shows how the circuit can be changed to relieve some of this strain and save one filter condenser at the same time.

Here the two cathodes of the rectifier tube sections are tied together, as are the plates. This lets us use the current capacity of the two diodes (which are now in parallel) to charge condenser C_1 , thus reducing the current each tube section must carry. The speaker field L_1 , in parallel with C_1 , is connected directly across the output of the rectifier. Enough filtering is produced by C_1 for the field supply. C_1 thus takes the place of condenser C_3 in Fig. 2, and at the same time acts as the input filter condenser for the filter C_1-L-C_2 .

► In very inexpensive receivers, the filter choke may be replaced by a

cheaper, but less efficient resistor. Fig. 4 shows a typical circuit. If the resistor R_1 could be made large enough so that the ratio of its resistance to the reactance of condenser C_2 was about the same as that of the choke reactance to condenser reactance, the filtering obtained would be approximately the same. However, a resistor this large cannot be used, because the d.c. voltage drop across it would be so great that little voltage would be left for the load. A smaller resistor must be used, hence, the filtering is not as good as that obtained with the average choke.

The resistor can be made larger, improving the filtering, if we can reduce the d.c. current flow through the resistor. As most of the d.c. required is for the plate of the output tube, it seems logical to divert this flow. By connecting the output tube plate circuit between terminal X and B— in Fig. 4, this plate current does not go through R_1 .

This method has the disadvantage that the only filtering given the out-

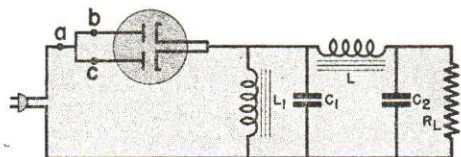

FIG. 3. The diode elements are in parallel, so have a greater current safety factor.

put tube plate supply is that furnished by C_1 , so a considerable a.c. ripple is fed to the output tube. However, since there is no amplification between the output tube plate and the loudspeaker, and since the output transformer and speaker will seldom respond to low frequencies in these inexpensive receivers, this ripple will not cause an objectionable hum.

If the screen grid of the output tube or any electrode of any other tube is connected to X, too much hum will be

produced. Therefore, all the rest of the tube electrodes are connected between B+ and B—, so they will benefit from the additional filtering of R_1 and C_2 .

Regulation. The filter systems of Figs. 1, 2, 3 and 4 are condenser-input filters. As you know, their regulation

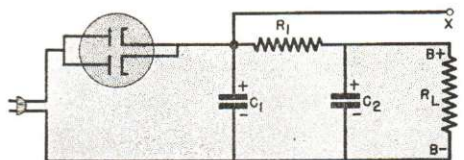

FIG. 4. Resistor R_1 is used in place of a choke coil, making a less efficient but still useful filter.

will depend on the amount of current taken by the load and upon the amount that condenser C_1 is discharged in between pulses of current from the rectifier. Just as in the standard power pack, the less the load current demand, or the larger the input condenser, the nearer the output voltage will approach the peak of the a.c. rectifier plate voltage.

Fig. 5 shows the regulation obtained with different sizes of filter condensers. You will notice that the d.c. voltage is high when low currents are drawn, but drops off very rapidly as the current demand is increased. It is easy to see that the condensers must be high-capacity types to give a reasonable output.

Tube Protection. As you already know, a large input condenser draws a high peak current from the rectifier tube. When a transformer is used, the resistance of the high-voltage winding limits the current through the rectifier tube to some extent; but the power line current in Fig. 3 is limited only by the fuses in the house wiring, which may have ratings as high as 25 amperes.

This is no protection at all for the rectifier tube. Many of these tubes

were ruined by excess peak current* before receiver manufacturers hit upon the idea of placing a resistor in series with the plates of the tubes. A single resistor of from 20 to 30 ohms may be placed in series with both plates at point *a* of Fig. 3, or a 50-ohm resistor may be placed in series with each plate at points *b* and *c*.

Now, even if condenser C_1 is considerably discharged, the maximum current flow is limited by the series resistor plus the tube resistance to a value less than 2 amperes. Even so, an overload lasting for a considerable time (which might be caused by a defective condenser) will either burn out the protective resistor or destroy the emission of the tube.

Filament Supply

So far, you have learned how to eliminate the power transformer and still obtain about 100 volts for plate and C bias supplies. Now how shall we supply the filaments?

Early a.c.-d.c. receivers used cathode type 6.3-volt a.c. tubes, obtaining the required filament voltage from the power line by using a resistor to drop the line voltage. Let's see how this can be done.

Suppose we have five tubes rated at 6.3 volts. If we connect these tubes in parallel, we will need 6.3 volts to operate them, and the total current demand will be the sum of all the filament currents. Presuming these five tubes have filaments rated at .3 ampere each, a current of 1.5 amperes

*Excess current through the tube will make the cathode lose its electron-emitting ability. It may even cause the plate to sag and touch the cathode. Usually, however, the metal strip inside the tube which is used to connect the cathode to the lead from the tube base acts somewhat like a fuse, burning out if the current is much greater than 2.5 amperes. This metal strip cannot be made heavy, because it would then conduct too much heat away from the cathode of the tube.

must be taken from the power line ($5 \times .3 = 1.5$). If we use a series resistor to drop the voltage from the line voltage value of 115 volts to the desired 6.3 volts, about 108 volts must be dropped in the series resistor. At a

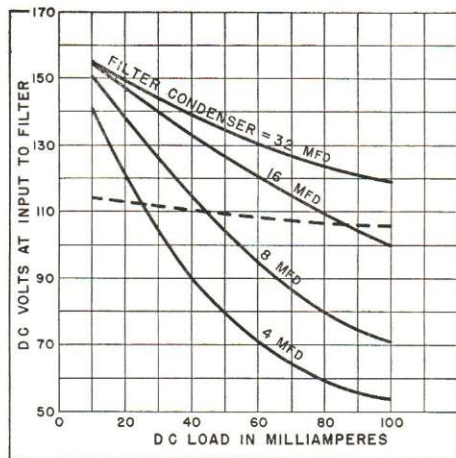

FIG. 5. Regulation curves for the universal power supply.

current of 1.5 amperes, the power dissipated in this resistor is about 162 watts. (Watts = current \times voltage, $1.5 \times 108 = 162$ watts.)

This is entirely too much power to waste. We will waste much less by arranging the tube filaments in series, as shown in Fig. 6.

Since the same current flows through all the parts of a series circuit, the tube filaments shown in Fig. 6 must have the same current rating. Let's assume again that this is .3 ampere, and that the tubes are 6.3-volt tubes. The voltage drop across the tubes will be the sum of their voltage ratings, so there will be about 31 volts dropped across the tubes. As a result, only about 84 volts must be dropped across the resistor R . At a current of .3 ampere, the power loss in the resistor is now only 25 watts. Obviously, this represents a great saving in power.

As soon as a.c.-d.c. circuits proved

practical, tube manufacturers began to make tubes with higher filament voltage ratings. The ratings jumped to 12, then to 25 volts. In particular, the rectifier and power output tube voltages were increased.

Since the current ratings of these tubes were kept at the same value as the available 6-volt tubes, the new tubes and the 6-volt tubes could be connected in series. As you know, voltage drops add in a series circuit—so using tubes with higher filament voltage drops means that less voltage must be dropped by resistor R . Consequently, less power is wasted in this resistor.

▶ When the tubes are in series, resistor R can be an ordinary 35- or 50-watt resistor, as long as it has the proper resistance value.* However, a regular 35- to 50-watt resistor is rather bulky; further, dissipating this amount

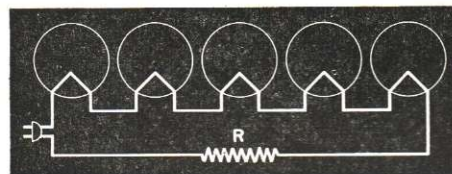

FIG. 6. The resistor drops the voltage to the amount required by the series-connected filaments.

of heat underneath the chassis may dry up the electrolytic filter condensers.

*You may have to figure the value of resistor R in some repair jobs. To do this, add the voltage drop across the tube filaments. Subtract this sum from 117 volts, which is considered the line voltage value. The remainder is the voltage which is dropped across the resistor R . Now look up one of the tubes in a tube chart to find what the filament current is. Divide the resistor voltage drop by this current value and you will get the resistance value. The wattage rating of the resistor will be the resistor voltage drop multiplied by the current through the resistor. To be safe, choose a resistor with a higher wattage rating than this figured value.

Ballast Tubes. To avoid excessive heat under the chassis, the resistor may be placed in a tube known as a ballast tube or resistance tube. This

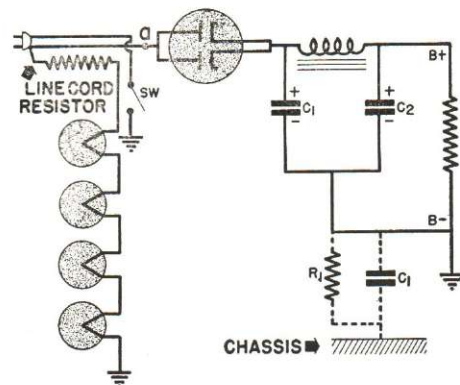

FIG. 7. Using a line cord resistor. In practical circuits of this type, you may find a protective resistor in series with the rectifier plates; also, there may be a speaker field connected across input filter condenser C_1 .

is a metal or glass tube with a regular tube base, which has only a resistance element in it. The resistance element is wired in series with the filaments of the other tubes, so the circuit is the same as Fig. 6. A ballast tube dissipates heat like all other tubes, from the top of the chassis, and so causes no heat under the chassis. Tubes with various resistance values may be obtained to suit the circuit.

Line-Cord Resistors. Another common voltage-dropping resistor is the Cordohm or line-cord resistor. This is a line cord having three (or more) wires. A typical circuit using a Cordohm is shown in Fig 7. Two of the wires form the regular a.c. power cord going to the B power pack. The third wire is a resistance unit of the proper size for the particular tube combination it is used with. This resistor value is figured the same way as an ordinary resistor, when a replacement is necessary. Wattage ratings need not worry you, however, as

these cords can safely dissipate 30 watts.

► Since this resistor unit runs the entire length of the cord, the cord will become warm. This may alarm some of your customers; if so, explain to them that the cord contains a resistor which is supposed to dissipate heat outside the set chassis. For this reason, such cords should always be stretched out to their full length, never bundled up inside the radio. Also, these cords should never be cut to shorten them, as this reduces the resistance, even if the proper connections are made.

Eliminating the Series Resistor.

In many of the more recent receivers, new types of tubes are used which have filament voltage ratings that add up to the line voltage total. A typical circuit is shown in Fig. 8. Here the 35Z5 rectifier tube requires 35 volts for its filament. The 50L6 output tube requires 50 volts, and the remaining tubes require 12 volts each. (Notice that the first part of the tube number shows the approximate filament voltage needed for the tube. This is standard practice in numbering the newer tubes.) The total is about equal to the line voltage, so no series resistor is needed.

Grounding Precautions

In Figs. 7 and 8, switch *SW* (the ON-OFF switch of the set) opens the filament and *B* supply circuits simultaneously by opening one side of the power line. Notice that one end of the switch, one end of the filament string and the *B*— terminal are shown going to ground symbols. *This means that these three terminals are all connected together.* For convenience, each point is often connected to the chassis; since the chassis is metal and a good conductor, this is exactly the same electrically as connecting the three wires directly.

Since one wire of the house power line is grounded and this ground is connected to the chassis by the cord of the receiver, no set wired like this should ever be connected to a ground by a separate wire. If it is, and the power cord plug happens to be inserted in the wall socket so the *ungrounded* wire of the house line is connected to

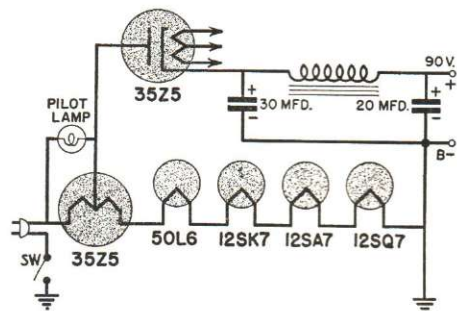

FIG. 8. The tube filaments have ratings adding up to the line voltage, so no series resistor is needed. (The 35Z5 tube filament is shown separately from the diode here for convenience; both are parts of a single tube.)

the chassis, the house line will be shorted through the set. Of course, this will blow out the power line fuses. **NEVER USE A GROUND CONNECTION ON AN A.C.-D.C. RECEIVER** unless a terminal is provided by the set manufacturer. And, for your personal safety, remember that the set chassis will be 115 volts above ground if the plug happens to be in the socket upside down. If it is, you will get a shock if you touch the chassis while you are standing on a concrete floor or other ground.

► In many a.c.-d.c. receivers, the chassis is not an electrical part of the circuit. In such sets, points marked with a ground symbol on diagrams are connected by a wire (often called a "bus"). The chassis may be connected to this ground bus through a condenser and resistor (*C*₁ and *R*₁ in Fig. 7). The chassis is indicated by the special symbol shown in this figure

when it is not used as a part of the circuit.

Dial Illumination

A pilot lamp is used in most radios to light the dial and show when the receiver is turned on. Let's see how the lamp is wired into the circuit.

The obvious way is to use a pilot lamp with the same current rating as the tube filaments, and connect it in series with them. Unfortunately, this method won't work. When the radio is first turned on, the tube filaments are cold and have lower-than-normal resistance. It takes several seconds for them to warm up. On the other hand, the pilot lamp warms almost immediately. Thus, when the radio is first turned on, the low filament resistance allows a higher-than-normal current to flow for a few seconds—which would burn out the pilot lamp.

Instead, we put a small resistor in series with the filaments, and connect the lamp across it. The lamp usually has a lower current rating than the tube filaments. The shunting resistor across the pilot lamp carries the difference in current between the pilot lamp rating and the current flowing in the circuit. For example, if the pilot lamp is rated at .15 ampere, and .3 ampere is flowing, the shunt resistor must carry the difference between the two, or .15 ampere.

The resistor has such a value that the voltage drop across the resistor and lamp is 4.25 volts * when the normal filament current flows. The drop is somewhat higher during the first rush of current, but now does not exceed the 6.3-volt rating of the pilot lamp. This means the lamp does not run at full brilliance except during the filament warm-up period. However, it

*The resistor value can be found by dividing 4.25 volts by the current it must carry. This current is the difference between the filament current and the pilot lamp rating.

gives enough light—and will not be burned out by the high initial current.

► When a series filament resistor, ballast tube or line cord is used, a tap on the resistor element may provide a shunt resistance, as shown in Fig. 9. If desired, the section *R*₁ can be a separate resistor.

► In Fig. 8, the 35Z5 filament in the filament string has a tap on it, so a pilot lamp can be connected across a part of the tube filament, which acts as the resistor element in shunt with the pilot lamp.

Connecting the plate of the 35Z5 to this filament tap, as shown in the diagram, makes it unnecessary to use a protective series plate resistor. This puts the parallel combination of the pilot lamp and the tube filament shunting section in series with the

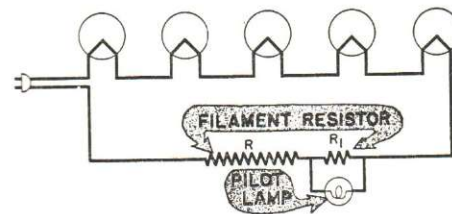

FIG. 9. The pilot lamp can be connected across a tapped section of the filament resistor.

plate of the rectifier tube; if too much current flows, the pilot lamp will burn out. Should the overload continue, this section of the tube filament may open. But usually, if the set is turned off quickly after the pilot lamp burns out, the pilot lamp will be the only part damaged. Before replacing the bulb, the filter condenser should be checked to be sure the overload is not the result of a defect in it. Incidentally, in any a.c.-d.c. receiver, a burned-out pilot lamp should be replaced at once. Never operate the receiver with the pilot lamp burned out, because another part may eventually be damaged.

► The most common pilot lamps for a.c.-d.c. sets are 6.3-volt bulbs rated at .15 or .25 ampere. The .15-ampere bulb has a brown colored glass bead supporting its filament, while the .25-ampere bulb has a blue bead. Naturally, you should always replace a lamp with another of the same rating.

► You will probably often be asked by owners of a.c.-d.c. sets why the pilot lamp flares up brilliantly when the set is just turned on, then grows considerably dimmer. The brilliance at the start is caused by the initial rush of filament current through the pilot lamp. Then when the tubes warm up, the current through the pilot lamp decreases, making the lamp less brilliant.

The pilot lamp shown in Fig. 8 will go through this same action, then become brighter again. As in Fig. 9, the first brilliant flare is caused by the extra current flow in the filament circuit. The pilot lamp dies down until it practically goes out as the filaments warm up. Then when the tubes draw plate current from the B power supply, the rectifier plate current flows through the pilot lamp and again lights it up.

Operation on D. C. Power Lines

Any a.c.-d.c. receiver can be used on a d.c. power line. All you need do is place the power plug in the wall socket in such a way that the plate of the rectifier tube is positive. Then current will flow continuously through the rectifier tube. The tube just passes on current, and does not act as a rectifier at all; however, it does act as a safety device for the electrolytic condensers. As you know, an electrolytic condenser will break down and become a low-resistance conductor if voltage of the wrong polarity is impressed across it. The rectifier tube prevents this from happening, because it will not pass current if the power plug is installed with the wrong polarity.

The dotted line in Fig. 5 shows the regulation obtained when d.c. voltage is applied to the input of an a.c.-d.c. receiver. Since the rectifier tube passes the needed d.c. average all the time, the filter condensers do not discharge, and the output voltage is practically independent of the effect of the filter circuit. Instead, it depends primarily on the resistance of the rectifier tube and filter choke. The only use for the filter circuit now is to remove any stray ripple voltages which may be on the d.c. power line.

Voltage Doublers

Sometimes, a higher voltage than is obtainable from the usual universal a.c.-d.c. power pack is wanted, without using an expensive transformer. This is made possible by another transformerless circuit called a voltage doubler. Let us see how it works.

Full-Wave Voltage Doubler

If we can charge two condensers, then put them in series so that their

voltages add together, we will get twice the charging voltage from the series combination. This is the theory of the full-wave voltage doubler circuit shown in Fig. 10.

This circuit resembles a half-wave rectifier circuit using a condenser-input filter, except that it has an extra condenser and an extra rectifier. The easiest way to understand its operation is to trace the flow of electrons.

When the a.c. cycle makes point 2 negative with respect to point 1, electrons will flow from point 2 to point 1. How do they get there? There are two possible paths, through C_1 - VT_1

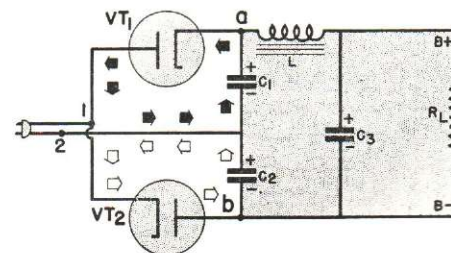

FIG. 10. This circuit doubles the line voltage without using a transformer.

and through C_2 - VT_2 . However, electrons cannot flow from a plate to a cathode, so the C_2 - VT_2 path from point 2 is blocked when point 2 is negative. Electrons flow instead into one plate of condenser C_1 , and an equal number of electrons are forced out of the other plate. This charges condenser C_1 with the polarity shown. The electrons leaving C_1 flow through VT_1 to point 1. The circuit is shown by the black arrows.

When the a.c. line voltage polarity reverses, electrons leave point 1 and, finding their way blocked by tube VT_1 , pass through VT_2 and charge C_2 . Those electrons driven out of C_2 during the charging process flow to point 2. This half cycle is shown by the outline arrows.

Notice that condensers C_1 and C_2 are alternately charged from the power line. Also notice the polarity of the voltages across the condensers. Since they are in series, the voltage between terminals a and b is approximately the sum of the condenser voltages. Of course, one condenser is being discharged by the load while the other is charging, so we don't get quite double the peak of the line voltage. The actual voltage depends

upon the amount of load and the size of the condensers.

This circuit is known as a full-wave voltage doubler because both halves of the a.c. cycle are rectified. Hence, 120 cycles is the lowest ripple frequency which must be filtered by L - C_s if the power line furnishes 60-cycle current.

► Fig. 11 shows the regulation characteristics of a full-wave voltage doubler in which condensers C_1 and C_2 are of equal value. Curves are shown for values of 5, 10, 20 and 40 microfarads for each condenser.

You can see that increasing the load current results in considerable voltage drop. In other words, the regulation is poor. The larger the capacity of the condenser, the less the drop in d.c. voltage for increased load current—but even at best, the regulation of this circuit is like that of a universal

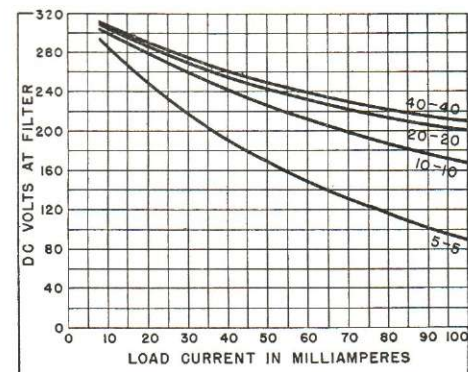

FIG. 11. The regulation of a voltage doubler is like that of the universal power supply.

a.c.-d.c. power pack, and is considerably worse than that of a transformer type power pack. It can be used satisfactorily only where the load current is not liable to vary greatly or where high currents are not required.

A Practical Circuit. Of course, Fig. 10 is a simplified circuit. A typical practical circuit, using a dual-

diode tube, is shown in Fig. 12. In its important details it is the same as the circuit shown in Fig. 10.

Let's trace the electron path through Fig. 12. When point 2 (near the power plug) is negative with respect to point 1, the path is from point 2 to point c, through C_1 to cathode K_1 , and from P_1 through resistor R_1 , to point 1. (R_1 and R_2 are protective resistors in series with the tube's plates.) On the next half cycle, the path is from point 1 to cathode K_2 , to P_2 , through R_2 to point b, through condenser C_2 to point c, and thus back to point 2. Therefore, the circuit works exactly like Fig. 10.

In addition, the filament circuits are drawn in. You can trace the cir-

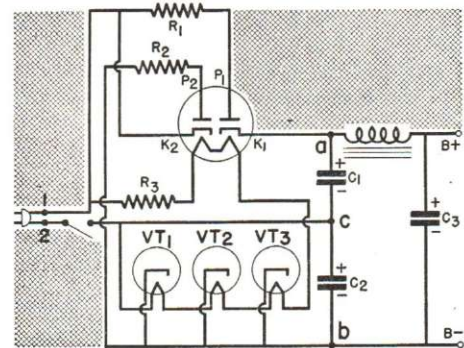

FIG. 12. A practical full-wave voltage doubler.

cuit from point 1 through resistor R_3 , through the filament of the rectifier tube and in turn through tubes VT_3 , VT_2 and VT_1 , back to point 2.

► Notice that the cathodes of tubes VT_1 , VT_2 and VT_3 all connect to B—, as is normal in radio receiver circuits, but the filaments are connected directly across the power line. The filament of tube VT_1 , which connects to point 2, also connects to point c (between the filter condensers). Therefore, the voltage difference between the cathode of this tube (which connects to point b) and the filament (which connects to point c) is the

voltage across condenser C_2 . This means there is a d.c. voltage between the cathode and filament of this tube which is approximately equal to the line voltage. Modern tubes have excellent insulation between the filament and cathode, so there is little danger of this voltage breaking down the tube between these elements, but a certain amount of leakage between them may develop. Since the filament of VT_1 is positive with respect to the cathode, it may attract some electrons from the cathode, so there can be a current flow through the space within the tube between the cathode and filament. The a.c. voltage across the filament will vary this leakage current and thereby create a certain amount of hum. As you will learn later, tube VT_1 is usually the first audio or detector tube, where not even a slight hum can be allowed. Careful tube selection for a minimum amount of leakage is necessary in these cases. Voltages exist between the cathodes and filaments of the other tubes, but leakage currents in these tubes are not so important.

Now let's look into another voltage-doubler circuit, which will solve some of this leakage current difficulty.

The Half-Wave Voltage Doubler

Like the full-wave voltage doubler, the half-wave voltage doubler uses a condenser as a voltage source—but as a source of voltage for a rectifier tube. Fig. 13 shows the basic circuit.

Suppose point 2 is negative with respect to point 1. Electrons will flow from point 2 into condenser C_1 , forcing other electrons out; these go to point 3, then through VT_1 to point 1. (Of course, there is no path for these electrons through VT_2 .) This charges C_1 almost to the peak line voltage, with the polarity shown. The electron path is shown by the outline arrows.

On the next half cycle, point 1 is negative with respect to point 2. Now electrons cannot travel through tube VT_1 ; instead, they move from point 1 through condenser C_2 , tube VT_2 and

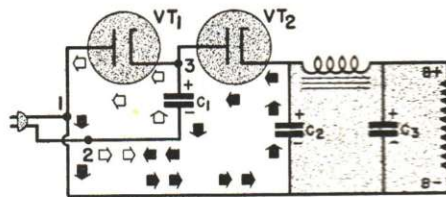

FIG. 13. The half-wave voltage doubler.

condenser C_1 to point 2, as shown by the black arrows. (This time, the path through VT_1 is blocked.)

Now just how does the voltage double? On the last half cycle, remember that point 1 was negative and point 2 positive. Since point 2 connects to the negative terminal of condenser C_1 , the voltage stored in C_1 adds to the line voltage, so that the voltage between points 1 and 3 is approximately double the line voltage. It is not exactly twice the line voltage, because C_1 is being slowly discharged by the load on this half cycle, but it is not far below double voltage if the load has a high resistance. This voltage is applied to tube VT_2 , so condenser C_2 is charged to almost twice the line voltage (and, of course, almost twice the line voltage appears between B+ and B—).

Since the current passes through rectifier tube VT_2 on only every other half cycle, this is a half-wave voltage doubler as far as condenser C_2 is concerned. Because of the half-wave action, the output voltage is somewhat less and the regulation is worse than a full-wave doubler.

► Notice that the B— terminal connects to one side of the power line in Fig. 13. This means that when the filament string is connected across the power line, there will be no d.c. volt-

age difference between the first tube cathode and its filament, and therefore no leakage current. We have thus improved upon the full-wave voltage doubler in one way, but have had to sacrifice some regulation to do it.

A complete half-wave voltage-doubler circuit is shown in Fig. 14. The action is identical to that of Fig. 13 as far as the B supply is concerned. Protective resistors R_1 and R_2 are used in series with the plates; also the pilot lamp P and its shunting section of the filament are between condenser C_1 and terminal 2—which is another protective feature. The current flow

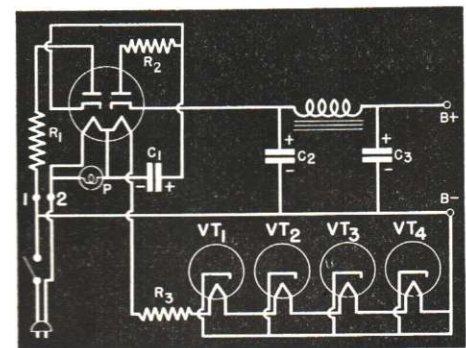

FIG. 14. A typical commercial half-wave voltage doubler.

for the B supply helps to keep the pilot lamp lighted.

The filament circuit includes a resistor R_3 to drop the voltage to the required amount for the tube filaments. The pilot lamp could be placed across a tapped section of R_3 , but this is unnecessary because of the pilot lamp tap on the rectifier filament.

Voltage Multipliers

You have seen how the line voltage may be doubled by using charged condensers and rectifier tubes. This method need not stop here—we could have voltage triplers, voltage quadruplers, etc. Of course, every time

the voltage is increased another step, the regulation becomes worse and the available current becomes less. For this reason, voltage doublers are the practical limit for most radio purposes. However, Fig. 15 shows how a voltage tripler can be made by adding an ordinary half-wave rectifier to a voltage doubler.

When terminal 1 is positive with respect to terminal 2, there will be an electron path from terminal 2 through condenser C_1 and tube VT_1 . At the same time there will be another path through tube VT_3 and C_3 back to terminal 1. Thus condensers C_1 and C_3 are charged on this half cycle.

On the next half cycle, electrons will move from terminal 1 into C_2 , forcing other electrons through VT_2 and C_1 . As in any half-wave voltage doubler, C_2 is charged on this half

cycle to double the line voltage. This voltage is then added to that of C_3 , so that three times the line voltage exists across C_2-C_3 .

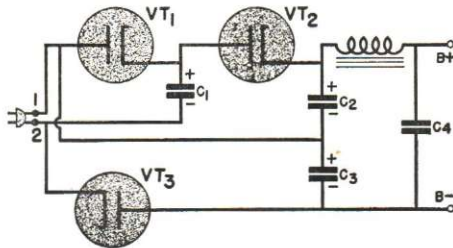

FIG. 15. A basic voltage tripler.

► A very important fact is that only a.c. sources can be used with voltage doublers, triplers, etc. No output can be obtained if a d.c. power line is connected to any of these voltage multipliers, because the polarity of a d.c. power line does not reverse.

Vibrator Power Supplies

So far, we have discussed power supplies which depend on a.c. or d.c. power lines. Power lines are not always available, however, so we must also consider other sources of power. Batteries are one such source, and can be used for portable or mobile equipment and for farm receivers, as will be discussed later.

In many locations, certain batteries are already available. On mobile devices such as automobiles, trucks, boats and airplanes, storage batteries of 6, 12, or 24 volts are used to operate the ignition and starting equipment; in many farm homes, 32-volt batteries are used for lighting purposes. These batteries furnish d.c. voltages which are adequate for filament supply but are not high enough to be used efficiently as plate and

screen grid voltage supplies. We could use additional batteries, as was done in early installations, but means have now been discovered for raising the voltages of these batteries to a higher and more efficient value. Let us see how this can be done.

► Anyone who has not studied the fundamentals of radio might say, "use a step-up transformer," but you know that a battery delivers only d.c. Since steady d.c. provides no changes in flux linkage, there will be no voltage induced in the secondary if a battery is connected to the primary of a transformer. However, if d.c. flows through the primary in pulses, there will be changes in flux linkage and an induced secondary voltage will result. You will recall from your study of coils that when d.c. is first applied, the

current rapidly builds up from zero to its maximum value and then flows at a steady rate. The flux linkages change as long as the current changes. Let's see how this idea can be applied to a battery and a transformer.

Suppose we connect a storage battery to the primary of a transformer as in Fig. 16A. When the circuit is first closed, current will flow through the primary; the resultant change in flux linkage will induce a large voltage across the secondary, as shown by 1-2 in Fig. 16B. The primary current will rise rapidly until it reaches its maximum value (determined by the resistance of the wire with which the transformer primary is wound), then remain constant until the circuit is broken. When the primary current becomes constant, the secondary voltage will drop to zero (2-3) and stay there, since voltage is induced only when there is a change in flux linkage.* When the primary circuit is opened, the current will cease flowing and the magnetic field will quickly collapse. This will cause another change in flux linkage, this time in the opposite direction, and a secondary voltage pulse will appear, as shown by 4-5-6 in Fig. 16B. This voltage will also drop to zero when changes in flux linkage cease.

► By using a step-up transformer and repeating this opening and closing regularly, we can get a series of alternate pulses from the secondary with high peak voltages.

From this, you can see that d.c. voltage can be stepped up with a transformer and changed into a.c. voltage if the primary circuit of the transformer is opened and closed fast enough with a switch. This allows the d.c. to flow in pulses which rise from zero to maximum and then de-

crease to zero again. Of course, if we could make the d.c. reverse in the primary, we would get more a.c. secondary pulsations, closer together—and thus obtain a greater a.c. output average.

Full-Wave Vibrators

Fig. 17A shows how we can make the d.c. reverse. Notice that the primary is center-tapped. One battery terminal connects to this tap; the other battery terminal connects to a switch arm which connects first to one outside primary lead and then to the other.*

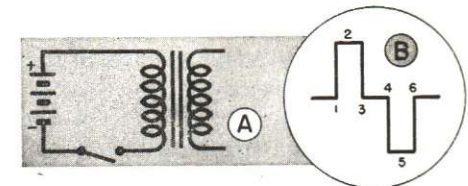

FIG. 16. A. C. can be produced by regularly interrupting a d. c. circuit.

Suppose the switch is thrown from position X to position Y. When the contact at X is broken, the current through P_1 drops to zero, as shown by line 1-2 in Fig. 17B. During the time it takes the switch arm to travel to position Y, the primary current remains zero. Then, as the switch arm makes contact at Y, we have current flow 3-4 through P_2 .

Since current flows in opposite directions through the windings P_1 and P_2 , a decreasing current in one produces a flux in the same direction as an increasing current in the other; therefore, the flux linkage change produced by current 1-2 decreasing through P_1 is in the same direction as the flux linkage change produced by

* One battery lead is grounded; it does not matter which one. The ground is shown because one terminal of a storage battery usually connects to the frame of the car or other device with which it is used.

* The primary current would probably be great enough to burn out the primary winding, if allowed to flow long.

current 3-4 increasing through P_2 . The change 1-2 produces a secondary voltage pulse like *a-b-c* in Fig. 17C. When the change 3-4 produces pulse *d-e-f* in the same direction.

Between 4-5 in Fig. 17B, the current through P_2 is constant and there is no change in flux linkage. When the switch arm is thrown from *Y* to *X*, the current through P_2 drops to zero, as shown at 5-6, and when contact at *X* is made, current P_1 rises as shown by 7-8.

The changing flux due to currents 5-6 and 7-8 produces voltage pulses *g-h-i* and *j-k-l*. Then currents 9-10 and 11-12 produce pulses *m-n-o* and *p-q-r*. Thus, we now get double pulses in the secondary instead of the single ones of Fig. 16.

► We could apply the secondary voltage shown in Fig. 17C to a rectifier tube, pass the tube output through a filter, and get a fair d.c. voltage output. However, there are several things wrong with these voltage pulses.

One is that the voltage consists of narrow double pulses in each direction, while we'd rather have pulses which are broader and not as high. We can get them by speeding up the switch shown in Fig. 17A, and by moving its contacts closer together, so that very little time elapses while the switch moves from one contact to the other. This means that the flat parts of the curve in Fig. 17B, where the current is zero (2-3, 6-7, etc.) are practically eliminated, so the primary current change will be almost a straight line between points 1 and 4, 5 and 8, 9 and 12, etc. As a result, each pair of secondary pulses will merge together, and there will not be much of a gap between opposite pairs of secondary pulses.

Even so, these pulses are very high, sharp peaks. This makes the filtering job difficult. It also produces sparking at the switch contacts, be-

cause each rapid change of flux in the transformer induces a back-electromotive force (back e.m.f.) in the primary which tends to cause arcing between the contact and the switch arm. This will burn and soon ruin the switch contacts.

The Buffer Condenser. The sparking problem is easily solved by connecting a low-capacity condenser (called a buffer condenser) between the secondary terminals.* Now, when

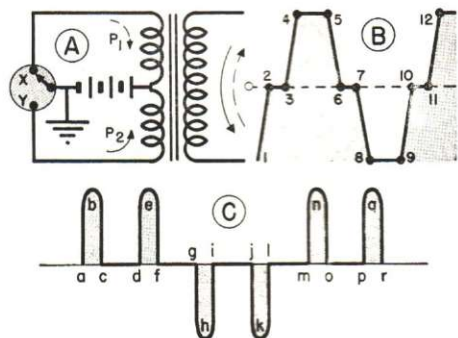

FIG. 17. Double voltage peaks are produced by using a full-wave interrupter.

the secondary voltage starts to rise, the condenser charges. This tends to reduce the sharpness of the peak in the secondary circuit, thus cutting down the back e.m.f. and thereby reducing the sparking at the vibrator contacts. Further, the discharge of the condenser when the secondary voltage begins to reverse helps to give us a secondary voltage more like that shown in Fig. 18—which has a shape approaching that which would be fed to a standard rectifier circuit.

Practical Vibrators

Fig. 19 shows how modern vibrators operate. The switch arm is a

* The condenser is chosen to work with a particular transformer and a certain rate of switch closure. Its capacity is quite important. When replacing a defective condenser, use the capacity and working voltage originally used by the manufacturer.

thin, flexible, spring-like metal reed. As it vibrates, it alternately closes contacts *N* and *O*, thus alternately closing the circuit through halves of the primary.

The shaded area shows the "motor" used to drive the reed. This motor is

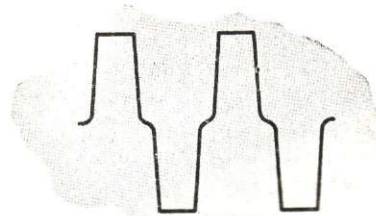

FIG. 18. The output of a vibrator-transformer-buffer condenser combination, which can now be rectified.

somewhat like the buzzer in an electric doorbell. Two types are used—the separate driver type and the shunt type.

Separate Driver. The separate driver type is shown in Fig. 19A. The vibrating reed is between *K* and *R*. Contact *M* is a spring contact which touches the reed when the reed is at rest. When the *ON-OFF* switch *S* is closed, electrons flow through contact *M* and electromagnet *L*. This energizes the electromagnet, which pulls up the soft iron bar *K* fastened to the end of the reed. This moves the reed, opening contact *M*, which breaks the circuit through the electromagnet. Since the electromagnet is no longer energized, the reed moves back to its original position, again closing *M*. Current again flows through *L*, and the cycle repeats as long as the battery is connected. The period of vibration of the reed depends on its mechanical characteristics—its length, springiness, etc.

In moving back and forth, the reed closes contacts *N* and *O* alternately. Each closure completes the circuit through one of the primary winding sections. The buffer condenser C_1 in

the secondary prevents arcing at contacts *N* and *O*. This does not affect the motor circuit and so does not protect *M*, therefore a separate condenser *C* is used across this contact.

The contacts are large and flat-surfaced, made from a hard grade of tungsten to reduce pitting and burning to a minimum.

The Shunt Motor. The shunt motor shown in Fig. 19B does not require a separate contact and is more widely used than the separate driver motor. When switch *S* is closed, electrons flow through the chassis (shown by ground symbols), electromagnet *L*, and primary winding P_1 . The electromagnet then pulls the reed upward, closing contact *N* and connecting the battery directly across primary P_1 . Contact *N* shorts the coil *L*, and the current now flows through *N* and the reed instead of through coil *L*, so the electromagnet releases; the reed springs back. Its springiness carries it beyond the resting position—this overshooting causes it to close contact

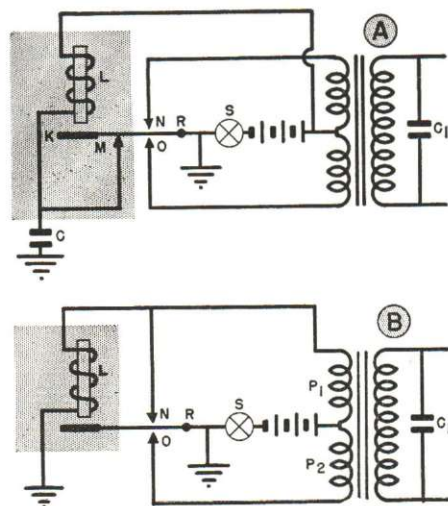

FIG. 19. Separate driver and shunt vibrator motor units. One or the other of these will be found on practically all commercial vibrators.

O. Then current flows through P_2 . When contact N is broken the current again starts to flow through L , and soon builds up enough magnetic pull to jerk the reed back and close contact N . This cycle of action is repeated as long as S is closed. We always have current flowing through P_1 (it flows through P_1 and L when N is open), but this current is much smaller than that when N is closed and does not have any appreciable effect on the wave form of the secondary voltage.

Rectification

Now that we know how a high a.c. voltage may be obtained from a d.c.

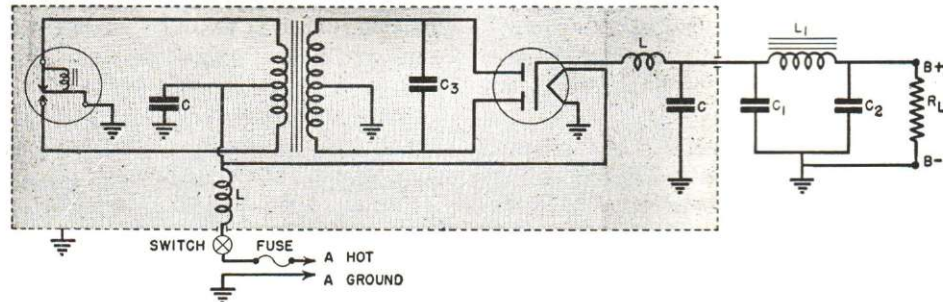

FIG. 20. A complete vibrator power supply using a tube rectifier.

source, let us see how this a.c. voltage is rectified. Fig. 20 shows a typical full-wave rectifier circuit commonly used for this purpose. The only real difference between this and an ordinary power pack is that the filament of the rectifier tube is supplied from a battery. As one battery terminal is grounded, the filament is at the same potential as $B-$. This means good insulation is needed between the cathode and heater of the rectifier tube, for as much as 400 volts may exist between them.

Also, the voltage pulses which result from rectification are still rather sharp and the rectifying process generates r.f. noise signals. R.F. filters, consisting of r.f. coils and small ca-

capacity condensers in the filament and $B+$ supply leads, prevent this interference (called "hash") from being fed to the other tube circuits. Direct radiation is prevented by complete shielding, as shown by the dotted lines.

► Notice that the two battery leads are marked A -hot and A -ground. The one marked A -ground connects to the grounded side of the battery. In power packs using tube rectifiers, it makes no difference whether $A+$ or $A-$ is grounded.

► If the filament current drawn by the rectifier tube can be eliminated the drain on the battery can be re-

duced. For this reason, cold-cathode rectifier tubes are sometimes used in auto radios. To refresh your memory of these tubes, refer to Fig. 21, which shows the structure of a typical full-wave cold-cathode rectifier. The tube is filled with gas which, on ionization, becomes an excellent conductor.

Rectification is caused by the physical structure of the tube. When one of the pointed plates is positive it can pull many electrons out of the large cathode. But when the cathode is positive with respect to a plate, the cathode can pull only a few electrons from the small surface of the plate; as a consequence, only a comparatively small current flows in the undesired direction. In other words,

the cold-cathode tube is a two-way conductor that conducts far better in one direction than the other.

The ionization of the gas in the tube causes a brilliant purplish glow which continually flickers as current through the tube changes. The cold-cathode tube has a serious disadvantage in that it generates a large amount of r.f. noise signal—much more than the mercury-vapor tube which it resembles. Often this interference is difficult to eliminate because of poor joints at shield contacts to the chassis, changes in the tube characteristics, etc. If you meet this difficulty, the easiest way to solve it is to rewire the circuit for a heater type rectifier. Usually it is only necessary to wire in the filament circuit,

Synchronous Vibrators. Sometimes it is desirable to eliminate the rectifier tube altogether, particularly where space limitations are important. Let us see how we can do so.

Basically, a rectifier tube is just an electronic switch that reverses a circuit connection every time the a.c. cycle reverses, and so keeps current flowing always in the same direction through the circuit. We can replace this electronic switch with a mechanical one—a vibrator—and get the same effect. Of course, this vibrator must be synchronized with the vibrator in the primary circuit so that both of them open and close their circuits at the same time. We can get this synchronization by mounting both sets of vibrator contacts on the same vibrating reed. This also helps to save space, by making two reeds unnecessary.

Fig. 22A shows the fundamental operation of such a circuit. Switch SW is synchronized with the vibrator, and replaces the rectifier tube. Notice that more is involved than a simple replacement of the tube by the switch;

the circuit is also changed around, with the rectifying element in the negative side of the output circuit. This is necessary because one side of the battery is grounded, which means that the vibrating reed is also grounded. As the same reed is used in SW , if we connected the switch in the positive side of the output (as we do with a tube) we would be grounding $B+$.

When current flows through the primary in the direction shown by the



FIG. 21. The elements of a gaseous or cold-cathode rectifier tube.

solid arrow, the polarity of the secondary voltage is that shown by the solid arrows drawn between the secondary terminals. Current flow through the other half of the primary reverses the secondary voltage polarity, as shown by the dotted arrows.

Notice that the center tap c on the secondary will be positive with respect to a when current flows one way through the primary, and positive with respect to b when current flows the other way. Obviously, switch SW must connect a to ground when a is negative with respect to c , and b to ground when b is negative with respect to c , in order to maintain the right polarity for the load R_L . Therefore, it must be synchronized with the primary vibrator. This is the reason these types are called "synchronous" vibrators, while the other type is known as the "non-synchronous" type.

► Fig. 22B shows the complete circuit of a practical synchronous vibrator, with both switch units operating from a common vibrator reed.

Either a separate driver or a shunt motor unit may be used, with the shunt type predominating. Notice that the whole unit is enclosed in a shield (dotted lines) and that r.f. filters *L-C* are used in both the *B+* and filament leads.

► You must be careful about the battery connections when you use one

This reverses the *B+* and *B-* terminal polarities, which prevents operation of the radio device. Further, this reversed polarity will ruin the electrolytic condensers if it exists for more than a few seconds.

Different polarities exist in various cars, boats, etc., where the batteries are used for ignition and other pur-

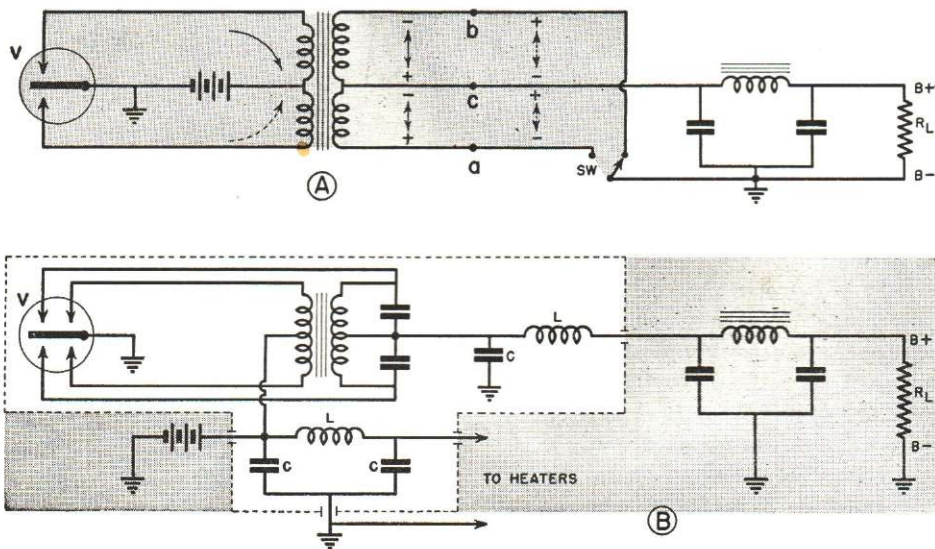

FIG. 22. The elements of a synchronous vibrator which uses mechanical rectification.

of these synchronous vibrators. When the battery polarity is reversed, the direction of current flow in the primary windings reverses, which interchanges the secondary polarities. Battery connections do not matter in a vibrator power pack which uses a rectifying tube—the tube automatically passes current in the proper direction, as whichever plate is made positive will pass current.

The synchronous vibrator pack is put together with a particular polarity in mind. Should the battery polarity be reversed, the secondary contacts would be closing to the *positive* terminals (with respect to *c* in Fig. 22A) instead of the negative terminals.

As the battery cannot be reversed, some provision is normally made for correcting this trouble, usually by providing a means of reversing the secondary contacts. A terminal board connection, or a vibrator which can be reversed in its socket is commonly used. Always check the vibrator output after the battery has been connected. If the output has the wrong polarity, reverse the connections by the means provided.

► While vibrator systems are most often found in cars, small boats and planes, they are also used in some farm receivers and may operate from a 2- to 6-volt storage battery or

from a 32-volt farm lighting plant. In the latter case, the receiver tube filaments are generally wired in se-

ries, as in an a.c.-d.c. receiver, to operate directly from the 32-volt supply.

Modern Battery Receivers

When you get into servicing, you'll find that receivers using batteries for their power supplies are very common; in fact, because of the wide popularity of modern portable radios, there are many more battery-operated sets in use today than there were in the days when batteries were the only source of power available. All these sets use A, B and C batteries—or suitable substitutes—to supply filament, plate and grid operating voltages. Let's look into the various ways these batteries may be used.

Filament Voltages

The cost and trouble of replacing worn-out batteries has always been one of the main objections to battery-operated receivers. To combat this objection, engineers developed battery tubes which required lower and lower current drains. The first battery tubes, for example, required 5 volts to supply their filaments. Since each tube drew .25 ampere (250 ma.), each filament consumed 1.25 watts. Then 3.3-volt tubes* which drew .132 ampere (132 ma.) made their appearance, followed by 2-volt, .06-ampere (60 ma.) types. Modern tubes need 1.4 volts and draw only .05 ampere (50 ma.)—a power consumption of only .07 watts, and the future will undoubtedly bring forth further progress in this line.

* It is common practice to speak of tube types by their filament voltage rating. Thus, we may have 50-volt tubes, 1.4-volt tubes, 6.3-volt tubes, etc.

► The filaments are generally connected in parallel to an A battery which furnishes about the correct voltage. If this voltage is too high, a series resistor is used to cut it down. Fig. 23 shows such a circuit; resistor *R* is used to drop the voltage to the correct amount. The difference in voltage between that required by the tubes and that furnished by the battery is the voltage which the

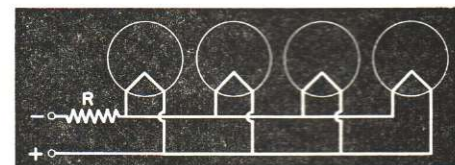

FIG. 23. Battery tube filaments are frequently connected in parallel.

resistor must drop. As the tubes are in parallel, *R* must carry a current equal to the sum of the filament currents. The value of *R* is then equal to the required voltage drop divided by the total current.

► Sometimes tube filaments requiring the same current are wired in series and supplied by an A battery which will deliver the sum of the tube filament voltages. This connection increases the A voltage required, but reduces the current drain to that used by only one tube, so the wattage (voltage × current) furnished by the battery is no greater than for parallel filament operation—and the lower current drain lengthens the life of the battery.

Grid Bias Voltages

Usually the control grid of a tube requires a bias to make the tube operate properly. This bias voltage normally makes the grid negative with respect to the cathode (or the filament in battery tubes).

The C Battery. A typical C battery arrangement for furnishing bias is shown in Fig. 24. This battery is made up of a series-connected group of 1.5-volt dry cells. It may have only two terminals, or it may have a number of taps to supply tubes needing different C bias voltages. Notice that $C+$ connects to $A-$, so the bias is applied between the grids and the negative sides of their filaments. The grids of VT_1 and VT_2 are connected together and have a bias voltage of -1.5 volts; the grid of tube VT_3 is biased 3 volts negative, while -4.5 volts is applied to the grid of tube VT_4 .

Since the grid circuit does not ordinarily draw current, the C battery usually has a long life.

The Bias Cell. Various means have been worked out to eliminate the C battery and thus save space in a receiver. A cell known as a "bias cell" is frequently used in battery sets—and also in a.c. receivers where small amounts of bias are needed and hum may develop if other supplies are used.

Essentially, the Mallory grid bias cell is a very small electrochemical cell with a potential of approximately 1 volt. Its current-supplying capacity is less than 1 microampere, but it can furnish voltage indefinitely as long as no current is taken from it. This makes it suitable for the grid circuit, where normally no d.c. is drawn from the bias supply. If strong signals drive the grid positive, the resulting grid current flow will be in such a direction as to recharge the

bias cell and thus help prolong its life.

► The cell consists essentially of an acorn-shaped metal cap or shell filled with an electrolyte, and a black disc which seals the circular end of the shell. The shell is the negative electrode, the black disc the positive electrode. The disc is insulated from the shell and sealed in place by a rubber gasket around its edges.

Suitable mounting brackets have been developed for this cell, usually consisting of a cup in which the cell fits and a spring contact which presses against the black electrode and holds the cell firmly in position. Mounting brackets holding as many as nine cells in series are available for applications requiring more than 1 volt. The cell is connected just like the C battery, except that its small size makes it possible to mount it right in the receiver.

► Bias cells must be checked with a vacuum tube voltmeter which draws no current, since the cell can't supply enough current to operate an ordinary type voltmeter. When replacing a bias cell, slip the old cell out of the mounting and slip in a new one. Make sure the spring arm has enough tension to make firm contact with the black electrode.

Convection Current Bias. Another method of biasing a tube depends on the fact that some of the electrons flowing in a tube hit the control grid wires and are collected by the grid. These electrons flow out of the control grid lead, through the external circuit, and back to the cathode. This flow is called a "convection current." If a resistor is placed in the control grid circuit, the electrons flowing through it produce a voltage drop which biases the tube. The end of the resistor connected to

the grid is negative, as the electrons enter this end.

The convection current varies with plate current, increasing with increases in plate current. Even at best, however, this current is so small that it is measured in microamperes, so a large resistor of 10 or 15 megohms is necessary to get enough bias.

Like the bias cell, the convection current method of biasing may be used with any type power supply. It is ordinarily used in a.f. amplifier stages.

Automatic C Bias. Another method of biasing the tube without the use of a C battery is shown in Fig. 25. Electrons flow from each tube filament to its plate, then to $B+$ and through the B supply to $B-$. In order to get back to the filaments,

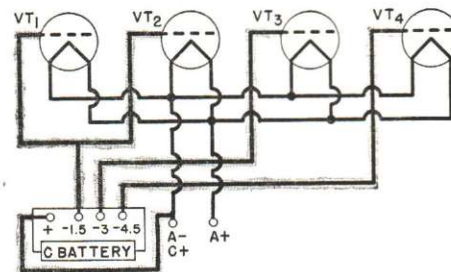

FIG. 24. Grid bias paths from a C battery.

the electrons must go through resistor R to the chassis, then through the chassis to the grounded terminal of the filament circuit. Therefore, the plate current from all of the tubes flows through resistor R . This produces a voltage drop across the resistor with the polarity shown. (Remember, the end of the resistor which electrons enter is always negative.) Suppose we bring the grid return of tube VT_4 to the negative side of resistor R . Then, the drop across the resistor makes the grid negative with respect to its filament—in other words, biases the tube. We can connect any number of grid returns to resistor R .

Of course, the bias voltage we get depends on the amount of plate current flowing and the value of the resistor in ohms.

This method is called "automatic bias," because the bias will auto-

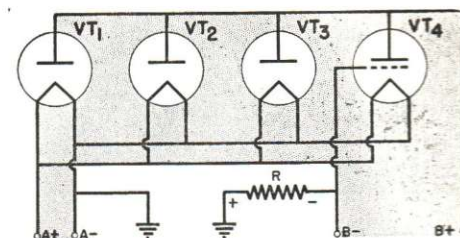

FIG. 25. The voltage drop produced by plate current flow through R produces an automatic C bias.

matically adjust itself for plate current changes, increasing when plate current increases and decreasing when plate current decreases. Notice that this method makes the B supply furnish the bias voltage.

Filament Biasing. One of the important reasons for connecting tube filaments in series is the fact that it is possible to get a bias voltage from the filament voltage drops. Fig. 26 shows how this can be accomplished. Here, the plate and grid signal circuit parts have been omitted for simplicity.

This circuit contains four 1.4-volt tubes, with the filaments in series. A 6-volt A pack is used, so there is a voltage drop of 1.5 volts across each filament, and .05 ampere flows through the complete circuit.

Tube VT_1 has its grid returned to point 1, which is the negative side of its filament. There is no bias on this tube, as there is no voltage difference between the grid and filament.

There is a drop of 1.5 volts between points 1 and 2. Since point 3 is connected to point 2, this same drop exists between 1 and 3. Therefore, if

we connect the grid of VT_2 to point 1 there will be a bias voltage of 1.5 volts between this grid and point 3 on the filament of VT_2 . Similarly, the 1.5-volt drop between points 3 and 4 can be used to bias tube VT_3 .

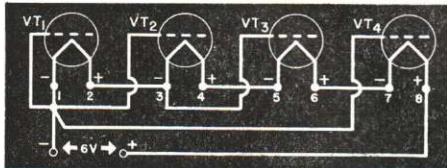

FIG. 26. The d. c. voltage drop across series-connected battery tube filaments can be used for bias too.

The grid of tube VT_4 is connected back to point 1. There is a 1.5-volt drop between 1 and 2, a similar drop between 3 and 4, and a third 1.5-volt drop between terminals 5 and 6, making a total of 4.5 volts between point 1 and point 7 (the filament of VT_4). Therefore, tube VT_4 has a bias of 4.5 volts.

The B Circuit

The B supply circuits in a modern battery receiver are very simple. The $B+$ supply leads are joined together and are connected to the $B+$ battery lead. The $B-$ terminal usually connects to the $A-$ filament terminal. The screen grid and other positive electrodes may connect to $B+$ or to a tap on this battery. Thus, the one battery supplies all the needed positive voltages. A series resistor may be used instead of a battery tap to provide screen grid voltages, particularly on the more modern sets. A bleeder is never used in battery sets, because the bleeder current would shorten the life of the B battery.

Typical Battery Sets

Now let's put together the things you've just learned, and study the

complete battery supply circuit in Fig. 27.

Two switches are "ganged" (connected) together in most battery sets and are used to turn the set ON or OFF. In Fig. 27, switch SW is the actual ON-OFF switch. When turned OFF, this switch opens the filament circuit and thus stops tube emission, which prevents the flow of plate current. The second switch, SW_1 in Fig. 27, serves to open the B supply circuit to prevent leakage paths from draining the B battery. This is necessary because, in many sets, by-pass condenser C_1 is an electrolytic, used to keep signal currents out of the B battery. Since all electrolytic condensers have a certain amount of leakage, there will be a constant drain on the B battery un-

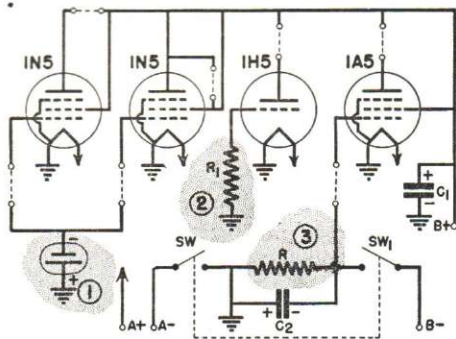

FIG. 27. Three biasing methods are shown here: 1, bias cell; 2, convection current; and 3, automatic bias.

less the B circuit through C_1 is opened by switch SW_1 .

With the switches closed, current flows through the tube filaments, heating them to the point where they can emit electrons. Plate current then flows from $B-$ through switch SW_1 , resistor R , and the chassis to the grounded tube filaments. The electrons return to $B+$ from the various screen and plate circuits.

In passing through resistor R , the plate and screen currents set up a voltage drop with the polarity marked

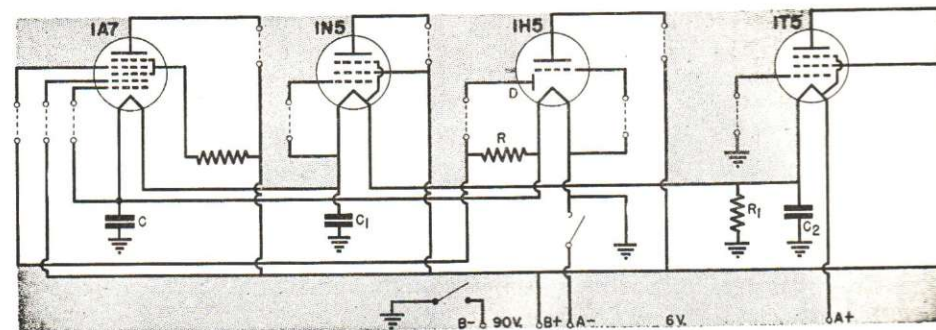

FIG. 28. Supply circuits in a typical modern battery portable receiver.

on condenser C_2 . The positive end of this resistor connects to the filament of the $1A5$ through ground and its negative end connects to the $1A5$ control grid. The voltage across R thus biases the $1A5$ control grid.

Resistor R_1 has a value of 10 megohms. Convection current through it produces a bias voltage for the $1H5$ control grid. Ordinarily, all three methods would not be used in the same chassis, but we have grouped them together here for convenience in illustration.

A Series Filament Circuit. The circuit shown in Fig. 28 appears complicated because the tubes are not arranged in the same order as their filament connections. The circuit may be more easily understood by referring to Fig. 29, which shows just the filament circuit and its associated parts.

You can readily see that these filaments carry more current than is supplied them by the A battery. Since the filaments are also the cathodes of the tubes and are connected in series, each one carries the plate and screen currents of all the tubes connected after it. Our circuit has a $1T5$ power output tube which has a fairly high plate and screen current. In order to prevent this current from overloading the filaments of the other tubes, we use resistor R_1 to shunt part

of the plate current of the $1T5$ around the filaments of the $1A7$, $1N5$ and $1H5$.

Tracing the current flow in the circuit, starting from $A-$ and $B-$, you see that the filament of the $1H5$ carries its regular current plus the plate currents of tubes $1A7$ and $1N5$, plus the plate current of the $1T5$ (the rest goes through R_1). The $1A7$ filament carries its own current plus the plate current of the $1N5$ and part

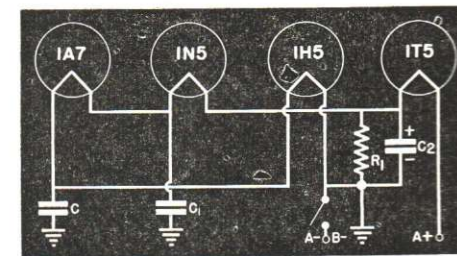

FIG. 29. The filament circuit of Fig. 28 shown in simplified form.

of the $1T5$ plate current, and the $1N5$ filament carries both its own current and the part of the $1T5$ plate current which did not go through R_1 . All these plate currents are the normal steady currents, which can usually flow through other parts of the circuit without causing any harm. But the signal currents (which, as you know, are variations impressed on the steady plate current) can't be

allowed to flow through the filaments of tubes other than their own, for this would cause undesirable coupling between stages.

Therefore, we provide condenser paths for the signal currents between the tube filaments and $B-$. The size of each condenser must be chosen so that the impedance it offers to the signal current it is supposed to carry will be far less than the resistance offered by any path through the filaments. Since $B-$ is grounded to the chassis, we ground one end of each condenser to the chassis and connect the other end to the filament of the tube with which it is to be used. Thus, the signal current of tube $1A7$ passes through condenser C , that of $1N5$ through C_1 , and that of $1T5$ through C_2 . Since $1T5$ is a power output tube and carries an audio frequency plate current, we must use a high-capacity electrolytic condenser for C_2 . It should be connected with the polarity shown. No condenser path is provided for tube $1H5$, because its signal current flows directly to it without having to go through any other tube first. ▶ Referring back to Fig. 28, you see that the $1T5$ is biased by grounding its control grid return, thus connecting it to $A-$ (which is 4.5 volts negative with respect to the $1T5$ filament). No external bias source is used for the $1H5$ and $1N5$ tubes. The $1A7$ control grid (fourth grid from the filament) is connected through resistor R to the filament of the $1H5$, which connects to the filament of the $1A7$.

You can readily see that any voltage drop across resistor R will make the $1A7$ control grid negative with respect to its filament. Now, when a signal (an a.c. voltage) is applied between diode plate D of the $1H5$ and its filament, the tube acts like an ordinary rectifier for which resistor R is the load. The amount of rectified voltage across R depends on the

strength of the signal. The greater the signal voltage, the greater the voltage across R and the greater the bias on the $1A7$. Since this bias controls the gain of the $1A7$ tube, we have a circuit in which the gain goes down for strong signals and goes up for weak ones—in effect, an automatic sensitivity control or, as radio men call it, an automatic volume control (a.v.c.). You'll study the automatic volume control in great detail later on, but even now you can see the principle on which it works.

The Three-Way Receiver

The chief use today for batteries is in portable receivers. To save batteries, it is desirable to be able to operate a portable on a power line whenever the set is used where a line is available. In other words, we'd like to have a three-way power supply which can use a.c., d.c. or batteries. Let's see what kind of a circuit we need to get it.

In the receiver shown in Fig. 28, we need 6 volts for the filaments and 90 volts as the B supply. The latter can easily be obtained from a power line by using the familiar a.c.-d.c. half-wave rectifier supply shown in Fig. 30. Between the $B+$ and $B-$ terminals there will be approximately 90 volts, so these terminals may be connected directly to the $B+$ and $B-$ receiver leads.

▶ The lowered filament current demand of modern tubes makes it possible for this rectifier also to supply power for the filaments, something not possible in the early days of radio. Modern tubes only require .05 amp. (50 ma.) for filament operation, so when in series, this is a value well within the rectifier tube limits.

A voltage divider consisting of R_2 and R_3 is used across the rectifier terminals to provide the filament voltage. The 6 volts needed for the A

supply appear across resistor R_2 . R_2 acts as a bleeder, making the A supply voltage more or less independent of tube drain.

The rectifier output is filtered by its own filter and also by the filament by-pass condenser C_2 in Fig. 29. This

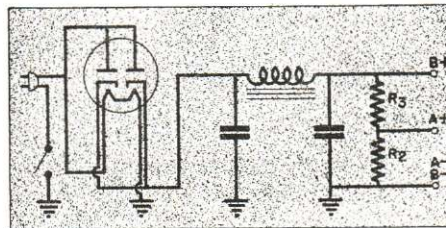

FIG. 30. This universal power supply can be used in battery sets to form a battery—a. c.-d. c. receiver.

condenser acts as a filter for tubes $1A7$, $1N5$ and $1H5$, because it is across the A supply as far as they are concerned. It does not act as a filter for the $1T5$, however, because the $1T5$ comes between the A supply and the points where C_2 bridges across the A supply circuit. Therefore, some hum currents flow through the $1T5$ filament; since this is the output tube, there is little amplification of the hum before it reaches the loudspeaker, so a small amount of hum is permissible.

▶ There is an important precaution you should remember when servicing three-way receivers. *Never pull out and reinsert a tube in its socket while the receiver is turned on.*

In receivers which have a bleeder resistor across the A supply (like R_2 in Fig. 30), pulling out and reinserting a tube while the set is on may cause

no trouble. But suppose you pull out a tube in a set having no bleeder across the A supply—what will happen? This breaks the circuit so there will be no filament current through the series resistor R_3 , and the voltage between the $A+$ and $A-$ terminals rises to practically the B supply voltage. If the pulled tube is any except the $1T5$, the condenser C_2 will charge up to this high voltage. When the tube is reinserted, this condenser discharges through the filaments; since C_2 is a large condenser, the discharge current may be great enough to burn out one of the filaments. To be on the safe side, *turn the receiver off while removing and replacing tubes.*

▶ We will not concern ourselves here with the various switching arrangements used to disconnect the batteries when the set is operated on a.c. or d.c., as these will be covered later. As a matter of fact, the batteries are sometimes left in the circuits at all times, and the output of the power pack is connected right across them. (No bleeders are used in such circuits, since they would drain the batteries. However, the batteries themselves act as bleeders across the power supply.)

This prolongs the life of the batteries, for the power pack sends a reverse current through the batteries at the same time it supplies A , B and C voltages to the tubes. Of course, the current through these dry batteries cannot recharge them, but it does drive off the hydrogen bubbles which form around the carbon electrodes. This reduces the internal battery resistance and helps the batteries last until they are completely exhausted.

Special Power Supplies

Sometimes neither power lines nor batteries can supply the power we need. For example, the power line may have the wrong voltage or frequency for the equipment we want to operate, and the device may need far more power than can be readily supplied by batteries. Let's see what special power supplies have been developed to meet such a situation.

Engine-Driven Generators

One way to get the power we want is to make it ourselves with a gasoline-driven generator. Usually we choose to develop 110-volt, 60 c.p.s.* power, so standard, easily-obtainable equipment may be employed. Most a.c. equipment is built for this frequency and voltage because they are found throughout the U.S.A., except for the relatively few districts having d.c., 25-cycle or 40-cycle a.c. lines.

► A typical gasoline-engine-driven a.c. generator is shown in Fig. 31. This type is used by servicemen in mobile public address installations, which usually require fairly large amounts of power. The unit is entirely self-contained and is furnished with a gasoline storage tank. Various sizes can be obtained, but a 300-watt unit is quite common and satisfies most needs. A 6-volt battery (usually a storage battery) is the only auxiliary equipment. It is needed to excite the electromagnets of the generator and to operate the ignition system of the gasoline engine. In an automobile installation, the car battery may be used. The output of the generator has a simple spark filter

* The abbreviation "c.p.s." stands for "cycles per second." Radio men frequently shorten this expression to "cycles," calling a 60 c.p.s. line a 60-cycle line.

(coil and condenser) to suppress interference.

Operating Equipment on Supplies for which They Were Not Designed

In your service work, particularly if the power line in your community is not the standard 60-cycle, 110-volt variety, you may be asked to make a set run on power for which it was not designed. Let's take up some of the most common problems of this sort, and see how you can solve them.

Adapting to a Line of a Different Frequency. Most a.c. power lines have frequencies of 25, 40 or 60 c.p.s. Occasionally you will have to install a radio receiver using a power transformer on a line having a frequency other than that for which the receiver was designed. Can a receiver de-

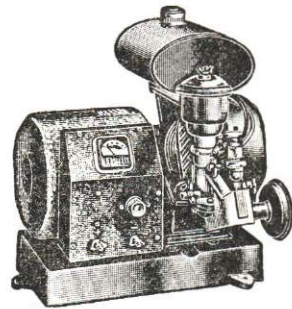

FIG. 31. A gasoline engine-driven generator of the type used in radio and public address work.

signed for one frequency be used on another? Yes and no!

For one thing, a receiver designed for 60 c.p.s. operation will not usually have a ripple filter sufficient to handle 40 to 25 c.p.s. Even more important, transformer equipment designed for low frequencies will work at higher frequencies (within reasonable limits) but the reverse is not true. That is, a 25 or 40 c.p.s. receiver will work with

a slight change on 60 c.p.s., but a 60 c.p.s. receiver should never be run on 25 or 40 c.p.s. lines. They may operate for a while, but in a short time the transformer will burn up.

The reason is that most transformer primaries are built to have a fairly high reactance at the frequency on which they're designed to operate; this prevents the primary from drawing large currents from the line. Low-frequency transformers, for example, have large, heavy iron cores to help give them the reactance needed. Now as you have already learned, the reactance of a coil is less the lower the frequency of the voltage applied to it. Therefore, a primary designed for 60-cycle lines will have a much lower reactance when it is used on 25- or 40-cycle lines, and so will draw much more current than it is designed to carry. This current overload will overheat the transformer and eventually burn out its windings.

Therefore, to operate a 60 c.p.s. receiver from a 25 c.p.s. line, the power transformer must be replaced with a 25 c.p.s. transformer having the same output ratings. Then extra condensers must be added in parallel with the filter capacities to increase the amount of filtering. If the pack has tuned filters, they must be retuned to 25 c.p.s. or the tuning parts removed.

► When a 25 c.p.s. or 40 c.p.s. receiver or amplifier is to be operated from a 60 c.p.s. line, the transformer will be more efficient at the higher frequency (because of its large core) and therefore will deliver a higher voltage than normal. If voltages more than 10% above normal are produced, you should use a line regulator (variable resistor) in series with the primary, and adjust the resistor until the voltages are normal. Special resistors for this purpose are available from radio supply stores.

D.C. Equipment on A.C. Lines.

Often people move from a 110-volt d.c. district to a 110-volt a.c. district. In this case it is best to recommend getting an a.c. receiver, because it will be much better than the d.c. receiver. But if the customer is satisfied with his d.c. receiver (and it is only a d.c. set, not a universal receiver), you could recommend a small a.c. motor-driven d.c. generator. This

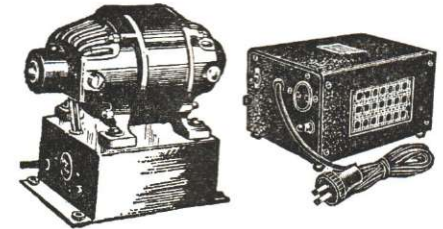

FIG. 32. Either the rotary converter at the left or the inverter at the right can be used to obtain 110-volt, 60-cycle a. c. power from d. c. power lines. The inverter is a high-power vibrator unit, using no rectifier.

equipment is usually more costly than a new receiver, however.

A.C. Equipment on D.C. Lines.

As a rule, a.c. receivers are so much better than d.c., universal and battery receivers that it is quite common to adapt a good a.c. receiver to 32-, 110- and 220-volt d.c. lines instead of buying a receiver designed for these special voltages. Two procedures are possible. Use a d.c. to a.c. rotary converter (a combination d.c. motor and a.c. generator) or a magnetic vibrator type d.c. to a.c. converter (often called an inverter). These devices are shown in Fig. 32.

For the average receiver, a 100-watt converter or inverter is large enough. Adaptation is simple—just insert the receiver power plug in the receptacle of the converter, then connect the converter to the d.c. line. If a ground terminal is provided on the converter, connect a wire from it to the regular ground. The rotary con-

verter is costly, but has a long life and can be had in any desired power rating for receivers or public address equipment; the magnetic vibrator inverter is comparatively inexpensive, but its power capacity is limited to 200 watts maximum, and the vibrator must be replaced about once a year.

Power Line Operation of Battery Sets

You may often wish to operate a battery receiver (not a three-way receiver) using 1.4-volt or 2-volt tubes from the a.c. power line. Power packs are available which do not take up any more room than the original bat-

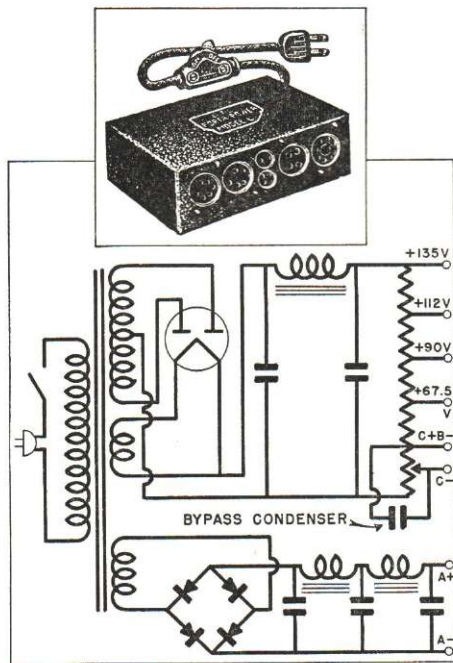

FIG. 33. This compact A-B-C power unit can be used in place of batteries so power-line operation can be obtained.

teries; in fact, the batteries may be removed and the power packs substituted for them. A typical power pack is shown in Fig. 33. A full-wave rectifier tube is used with an untuned filter to provide B and C voltages. The B section of the voltage divider is tapped to provide any voltage normally required, while various values of C voltage are obtained by adjusting the slider on the lower section of the divider.

A copper-sulphide (similar in action to a copper-oxide) type rectifier is used in a full-wave bridge circuit for the A power. Filters in cascade furnish hum-free A voltage.

Copper-sulphide, copper-oxide and a recently developed selenium-iron unit are metal discs, specially prepared to act as rectifiers. These rectifiers have very low voltage drops and can be designed to carry high currents, so are better than receiver-type tubes where low-voltage, high-current power is needed. Vacuum tube rectifiers have an internal drop of 15 or more volts, which may be half or more of the available voltage in a low-voltage circuit and so represents a large power loss. (Tubes are better in high-voltage circuits, where 15 volts may be only a 3 or 4% loss and where disc rectifiers cannot withstand the high peak inverse voltages.)

These units have the characteristic of letting electrons flow in one direction much easier than in the other. The elements are bolted or clamped together with insulating washers in such a manner that all four sections of a bridge make a single unit having four connections.

Lesson Questions

Be sure to number your Answer Sheet 13FR-2.

Place your Student Number on every Answer Sheet.

Send in your set of answers for this lesson immediately after you finish them, as instructed in the Study Schedule. This will give you the greatest possible benefit from our speedy personal grading service.

1. What is the maximum possible voltage which could be obtained from a universal a.c.-d.c. power supply, operated from an a.c. 115-volt power line, with no load?
165 ✓
2. Why is a condenser-input filter used instead of a choke-input filter, in a universal a.c.-d.c. receiver power supply?
THERE IS NO VOLTAGE DROP IN THE CONDENSER-INPUT FILTER.
3. What is the purpose of placing a resistor at point a in Fig. 3? *TO PREVENT THE BATTERY FROM DRAINING*
4. Suppose you are replacing the pilot lamp in a universal receiver. Is the current rating of the replacement lamp important?
YES
5. Can a transformerless receiver using a voltage doubler be operated from a d.c. power line?
NO
6. In connecting a receiver having a non-synchronous vibrator and tube rectifier, does the polarity of the storage battery matter?
YES - THE BATTERY POLARITY MUST BE CORRECT OR THE RECEIVER WILL NOT OPERATE.
7. Name five methods of getting C bias in a battery receiver.
INDUCTIVE COILS, FILAMENT WINDING, RESISTORS, CAPACITORS, AND TRANSFORMERS
8. Why is switch SW₁ used to open the B supply circuit when turning off a battery receiver like the one shown in Fig. 27?
TO PREVENT LEAKAGE PATHS FROM DRAINING THE 'B' BATTERY
9. What type of meter must be used to check a grid bias cell?
VACUUM TUBE VOLTMETER
10. Why are copper-oxide (or selenium) rectifiers always found in low-voltage, high-current power supplies, instead of vacuum-tube rectifiers?
THE VACUUM TUBE HAS A HIGH VOLTAGE DROP AND RESULTANT HIGH POWER LOSS



FIRST IMPRESSIONS

First impressions mean a lot in this busy world. An applicant for a job has a pretty tough time making the grade if his appearance and first few words do not make a favorable impression on the employment manager. A salesman likewise gets the “cold shoulder” if there is anything about him which annoys the prospect.

With technical material of any kind, however, first impressions can be very treacherous. Oftentimes a simple technical book will contain a number of apparently complicated diagrams, charts, graphs, sketches or tables. Since we glance mostly at illustrations when inspecting a book, we are apt to get a misleading impression. Also, paragraphs, pages or entire lessons may seem difficult during the first reading, but become almost magically clear during the second or third reading.

If first impressions of a required task are favorable, fine and dandy; if unfavorable, don't be discouraged, but wade right into the work and give it a chance to prove that *first impressions don't always count.*

J.E. Smith