

**HOW OPERATING VOLTAGES ARE
OBTAINED FROM AN A.C.
POWER LINE**

12FR-2

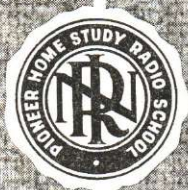

NATIONAL RADIO INSTITUTE

WASHINGTON, D. C.

ESTABLISHED 1914

HOW OPERATING VOLTAGES ARE OBTAINED FROM AN A. C. POWER LINE

STUDY SCHEDULE NO. 12

For each study step, read the assigned pages first at your usual speed. Reread slowly one or more times. Finish with one quick reading to fix the important facts firmly in your mind, then answer the Lesson Questions for that step. Study each other step in this same way.

- 1. Power Supply Requirements. Pages 1-3
All radio apparatus can be divided into signal circuits and power supply circuits. Here you learn what these circuits are intended to do, then you study the requirements for proper power supply operation. These are very important, because many radio troubles result from a defect causing improper power supply operation. Answer Lesson Questions 1 and 2.
- 2. Filament Power. Pages 3-7
Tube filaments must be heated enough to give proper electron emission. Excess filament voltage will ruin the tube, while too little does not give proper operation. When a. c. is used, special precautions are necessary to avoid hum-producing variations in the plate current. Answer Lesson Question 3.
- 3. Obtaining D. C. from A. C. Pages 7-11
After settling the filament problem, we must supply the plate and grid elements with pure d. c. power. The line voltage is stepped up and then rectified, so a pulsating d. c. is obtained. Half-wave rectifiers will work, but full-wave types are more efficient, as is proved here. Notice the importance of balanced tubes—hum will result from improperly matched full-wave rectifiers. Answer Lesson Question 4.
- 4. Taking out the Ripple. Pages 12-20
The pulsating d. c. from the rectifier is a combination of d. c. and a. c., so the a. c. must be removed for proper radio performance. The standard filter is a coil-condenser combination, arranged so most of the a. c. is dropped in the coil. The choke input and the condenser input types differ in their operation, d. c. voltage output and effects on the rectifier. This section should be studied and restudied. Refer back to it later on, as many very important facts are presented here. Answer Lesson Questions 5, 6 and 7.
- 5. Dividing the Voltage. Pages 20-25
The filter delivers the pure d. c. needed, but the voltage is a maximum and usually too high, particularly for many of the grid circuits. By using Kirchhoff's and Ohm's Laws, it is easy to figure the resistor values needed to drop the voltage to the required amount. Also, you learn how bleeder currents prevent load changes from reacting on the power supply and thus affecting the voltages delivered to other stages. Answer Lesson Questions 8 and 9.
- 6. Facts About Rectifier Tubes. Pages 25-28
There are two general types of rectifiers—vacuum types and the mercury vapor types. The difference in regulation and current handling ability should be carefully noticed, so the wrong tube won't ever be used. Answer Lesson Question 10.
- 7. Mail your Answers for this Lesson to N. R. I. for Grading.
- 8. Start Studying the Next Lesson.

Power Supply Requirements

WHEN you become an expert at tracing circuits, whether you are working on a receiver, a transmitter, or some sort of electronic control, you will automatically divide the device into two parts:

1. *The signal circuits.*
2. *The power supply circuits.*

These two circuits can always be considered separately. In fact, special filters are almost always used to keep them from reacting on one another.

One very important fact you must remember about any modern radio receiver is that it uses the tiny amount of electric power picked up by the antenna to excite a tube or tubes. These tubes in turn control a relatively large amount of power furnished by the batteries or other power source. The circuits which *control* the power are called the signal circuits—the circuits which *furnish* the power are called the power supply circuits.

Both kinds of circuits use resistors, condensers, coils, transformers and tubes. You've already studied the basic actions of these important radio parts. Now you're ready to learn all the facts about their many uses in radio circuits. It's this knowledge, which you'll gain from this and succeeding lessons of your N.R.I. Course, that will make you an expert technician—able to operate and repair all types of radio equipment.

A great many of your later lessons

will be devoted to the signal circuits of modern radios. In this lesson, you're going to learn all about the equally important power supply circuits, without which no radio could operate. You should study this lesson very carefully, for the information it gives you will be useful all through your radio career.

WHAT THE POWER SUPPLY MUST DO

A radio tube works best when the voltages applied to it have proper polarities and values. The plate, control grid, screen grid and suppressor grid electrodes all require different operating voltages with respect to the cathode of the tube. As you've already learned, these voltages must make the screen and plate *positive* with respect to the cathode, and must make the control grid and suppressor grid *negative* with respect to the cathode. (In some cases the suppressor grid is connected directly to the cathode, and then there is no difference in potential between them.) The filament of the tube must be heated so that electrons will be emitted. You must apply just the right voltage to the filament to heat it properly.

► Thus, one important requirement we must make of the power supply is that it furnish the proper operating voltages for the various tube circuits. Another is that the power supply must not interfere with the operation of any stage by introducing undesirable

voltages. Only the signal voltage applied at the input of the tube should control the output of the stage. We do not want supply voltages to have a ripple component which might act just like a signal and make the loudspeaker produce noise or hum. For this reason, the power supply must be a pure d.c. power source with a minimum of variation or ripple.

Finally, we do not want the power supply to transmit signals from one stage to another. You can easily see that signals straying through the power supply would be as bad as having variations in the power supply.

► Let's repeat these three important things required of the power supply, in order to fix them in your mind:

1. It must provide the correct amount of voltage to each tube electrode. Each voltage must have the correct polarity. (As you will soon learn, these voltages may have to be values between 1 or 2 volts and several hundred volts.)

2. It must furnish as near a pure d.c. voltage as possible to those electrodes where variation would produce distortion, interference or unwanted signals.

3. It must not transmit signals from one stage to another. This means that the power supply circuits and the signal circuits can be, and are, electrically separated from each other—which, as you've learned, is the reason we can study them individually.

► Of course, these requirements must be met by any power supply which may be used. Now, let's see what kinds of power supplies have been developed.

BATTERY SUPPLIES

Batteries meet all the requirements of a power supply—cells can be added to get the required voltage; a pure d.c. is delivered; and their low internal resistance causes little signal volt-

age drop, thus minimizing unwanted signal transfer between stages.

► In fact, batteries are such perfect sources of d.c. power that engineers frequently draw battery symbols in their diagrams to show that a d.c. supply is wanted.

► A simple battery supply circuit is shown in Fig. 1A. The signal circuit parts which you would ordinarily expect to find in the control grid and plate supply leads have been omitted to simplify this drawing. These parts

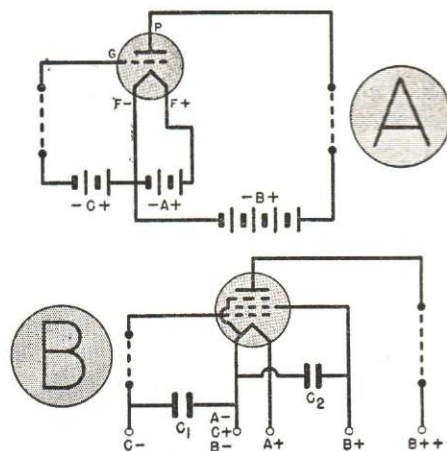

FIG. 1. Power supply connections for a triode and a pentode are shown in A and B respectively. Bypass condensers C_1 and C_2 are used to keep stray signals out of the power supply.

—which might be resistors, coils or transformer windings—would be connected between the points which are connected by the dotted lines.

In Fig. 1A, we have an A battery supplying power to operate the filament, a B battery to operate the plate circuit and a C battery to supply the necessary grid bias. These batteries are usually made up from dry cells, although a storage battery or an air-cell battery may be used as an A supply.

► Although batteries have these very desirable characteristics, they are ex-

pensive, bulky, and must be changed or recharged at frequent intervals. Therefore, as soon as radio became popular, many experts searched for ways to eliminate batteries by converting a.c. from the power line wall outlet into continuous or d.c. power. At first, they tried to get pure d.c. for all tube elements, including filaments. However, the high-current, low-voltage supply needed for filaments demanded special, expensive equipment—so an a.c. type tube, whose filament could use a.c. directly, was developed.

High d.c. voltage is easily produced from the a.c. power line, particularly if the current demand is not too high. Once we have a high d.c. voltage, it is a simple matter to divide it so that the grid and plate elements receive the proper amount of voltage.

► Let us now see how the power supplies work which use power transformers to operate from standard a.c. power lines. First, we will take up filament voltage supplies, then study the rectifiers, filters and voltage dividers used to obtain power for the other tube elements.

Filament Power

A d.c. voltage applied to a tube filament will neither cause changes in the plate current wave form nor introduce hum. However, when a.c. is applied, we must take special precautions to make sure the filament heat does not vary and to prevent the a.c. from affecting the grid bias and plate voltage. Let's see what these precautions are for a tube which uses a filament as the cathode or electron emitter.

number of electrons emitted from a filament depends on how hot the filament gets, this varying filament heat will produce a varying electron flow from the filament to the plate. This pulsating plate current, varying 120 times a second, will produce a loud hum.

We can prevent the filament heat from varying by using a filament so thick that, once it is warmed up, it tends to stay at a constant heat. This is exactly how a.c. filament tubes are made.

► You can now see why battery type tubes are not satisfactory when their filaments are powered from an a.c. source—and also why battery receivers using tubes with thin, quickly-heated filaments go into operation faster than a.c. receivers using heavy filaments which take a longer time to heat.

► A heavy, heat-holding filament solves only one of the problems involved in a.c. filament operation. Still other precautions must be taken to prevent an a.c. filament supply from producing a.c. ripple in the plate current.

FILAMENT TYPE TUBES

Getting Constant Heat. When a.c. is fed to the filament, the current rises to a peak twice for each cycle, once on the positive and once on the negative alternation. The heating effect is the same on either alternation. Thus, the filament will be subjected to a maximum heating current 120 times a second if standard 60 c.p.s. (cycles per second) current is used. If the filament is very thin, as it is in most battery-operated tubes, it will become hot, then cool off, 120 times a second. Since, as you recall, the

Getting Constant Emission. Now let us see how an a.c. filament voltage can affect the grid voltage. Look at Fig. 1A. Here we can measure the grid voltage by touching the negative probe of a voltmeter to the grid *G* and the positive probe to $-A$. Since $+C$ connects to $-A$, the voltmeter is connected across the C battery and measures the C battery voltage.

Suppose, however, that we connect the positive voltmeter probe to $+A$. Will we measure the same grid-filament voltage as before? No—because now the A battery voltage will add to the C battery voltage, and we will actually measure the C battery voltage plus the A battery voltage.

Since the grid is more negative with respect to the right-hand side of the filament than to the left-hand side, the number of electrons leaving the right-hand side of the filament is considerably less than the number leaving the left-hand side.* We don't care about this when d.c. is used on the filament, because the total emission remains constant, and the plate current is not varied by the filament voltage.

When a.c. is used to heat a filament, we cannot connect $+C$ to either side of the filament. Fig. 2, where such a connection is made, shows you what would happen. Here the plate has been omitted for simplicity, and the

* When d.c. filament voltage is employed, this results in extra wear on the side of the filament emitting most of the electrons. This effect is unimportant in low-power receiving tubes, but in transmitting tubes where the plate current may be very high, the connections to the filament leads of large tubes are disconnected and reversed about once a week in order that both sides of the filament may receive equal wear. When the filaments of low-power tubes are fed with d.c., as in Fig. 1A, the $+C$ and $-B$ connections of the electrode voltages may be connected either to $-A$ or $+A$ filament terminals; the $-A$ terminal connection has become standard for most circuits.

filament is shown as a straight resistance wire because it has resistance. This representation will help you to picture the voltage drop that exists across the filament when filament current flows through it. The C battery furnishes 3 volts d.c., while 6 volts a.c. are used to heat the filament. At the particular instant illustrated, the a.c. voltage gives the filament the polarity shown.

Starting with Fig. 2A, the voltage between the grid and point *a* on the filament is -3 volts. As we move along the filament, the grid-filament voltage becomes progressively greater as the voltage drop along the filament resistance is added to the bias voltage. Between the grid and *b* it is $-4\frac{1}{2}$ volts; at *c* (the center of the filament) it is -6 volts, and at *d*, where all the filament voltage drop is added to the bias voltage, it is -9 volts. Naturally, most of the electrons reaching the plate come from the section between *a* and *c*, because the grid is less negative with respect to this part of the filament.

If the supply current is 60-cycle a.c., the filament voltage will reverse polarity so that in $1/120$ of a second we will have the condition illustrated in Fig. 2B. The voltages between the grid and various points on the filament at this instant are indicated in the diagram. As you see, the filament voltage drop is now *subtracted* from the 3-volt grid bias voltage. This creates an over-all decrease in grid-filament voltage—and so considerably increases the total number of electrons reaching the plate, as compared with the number which reached it during the previous half cycle.

In another $1/120$ of a second, the conditions are again as shown in Fig. 2A. As a result of these changes in grid-filament voltage, the plate cur-

rent alternately increases and decreases. This causes hum.

It makes no difference to the plate from which part of the filament electrons come. The important thing is that the *total number* remain constant (except, of course, when a signal voltage is applied between the control grid and filament).

We can get constant electron emission by connecting $+C$ to the center of the filament, as shown in Fig. 2C. The voltages between the grid and

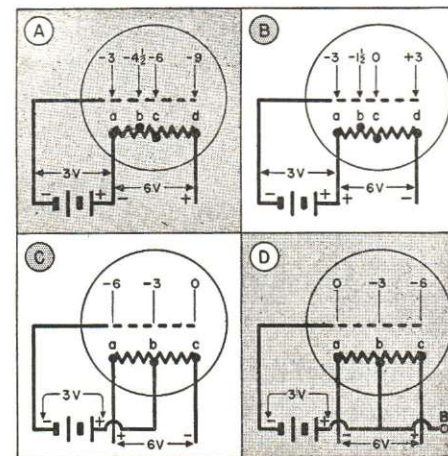

FIG. 2. When a.c. is used to heat the filament, a center tap is necessary to prevent hum.

points *a*, *b* and *c* on the filament when the supply voltage has the indicated polarity are shown directly above the grid symbol. For simplicity, suppose that from point *a* we get 2 electrons, from point *b* we get 8 electrons, and from point *c* we get 14 electrons. (Actually, of course, the number of electrons is far greater.) This makes a total of 24 electrons reaching the plate.

When the filament polarity reverses $1/120$ of a second later, the grid-to-filament voltages at *a*, *b*, and *c* will be those shown in Fig. 2D. Now from *a* the plate gets 14 electrons, from *b* it gets 8 electrons, and from

c, 2 electrons. In all, the plate receives $14+8+2$ or 24 electrons, the same number it did in 2C. Thus, a center-tapped filament allows us to maintain a constant flow of electrons to the plate throughout the a.c. filament cycles, even though the amount from any one spot on the filament is varying. (The signal voltage will, of course, still vary the plate current, because it changes the voltage between the grid and all points on the filament at one time.)

► The plate-to-filament voltage would vary just like the grid-to-filament voltage if we connected *B*—to one end of the filament. We can prevent this variation (which would of course cause a varying plate current) in exactly the same way—by also connecting *B*—to the center tap of the filament, as shown in Fig. 2D.

Getting a Center Tap. You see that a grid and plate connection to the center of the filament will eliminate a.c. variations in the plate current. While it is perfectly possible to build a tube with a filament center tap, this is not necessary. We need only connect $+C$ and $-B$ to a center-tapped resistor across the filament (see Fig. 3A).

Let's see why. In Fig. 3B, we have a tube filament connected between points *A* and *B*. As you've learned, each point along the filament will have a different voltage with respect to one end of the filament. For instance, with 6 volts applied and measuring from point *A*, there might be 1 volt at *c*, 4 volts at *d* and 5 volts at *e*.

If we connect a resistor in parallel with the tube filament between *F* and *G*, the same total voltage will be across this resistor—and there will be differences in voltage between point *F* and other points on the resistor. There will be a point on the resistor where

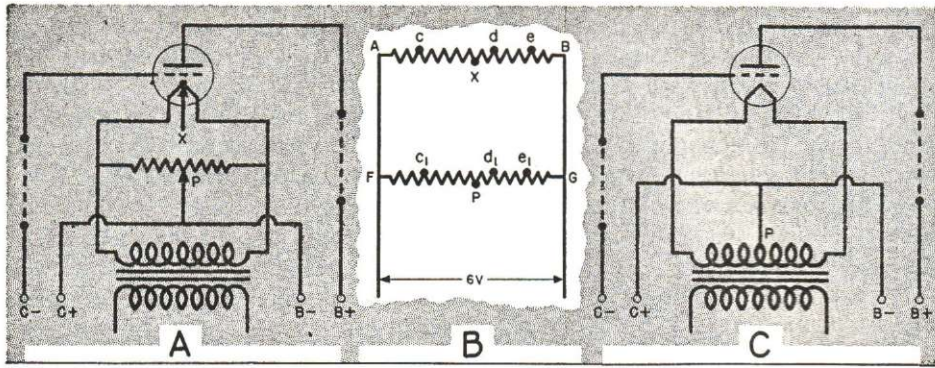

FIG. 3. Practical ways of getting the center tap.

this difference is 1 volt. This is marked c_1 to correspond to the same point on the tube filament. Similarly, a 4-volt difference will be found at point d_1 , and a 5-volt difference at e_1 . Points F and A are at the same potential, since they're connected together by a wire.

For every point on the tube filament, there will be a corresponding point on the resistor which will have the same potential with respect to terminal A . Thus, center tap P on the resistor has the same potential with respect to terminal A as has point X , the center of the filament. Since P and X are both in the same circuit and are both at the same potential, we get precisely the same electrical effects by connecting an outside circuit to point P as we would by connecting it to point X .

► Frequently, a potentiometer (variable resistor) is used across a tube filament instead of the fixed-tap resistor, as shown in Fig. 3A. Then, if the electronic emission from the filament is not the same over its entire length because of imperfect manufacture, we can find a point on the resistor which corresponds to the emission center of the filament by moving point P to the right or left. Hum disappears or is reduced to a minimum when the correct adjustment is

made. Usually tubes are manufactured with sufficient care so that a movable tap on the resistor is not required.

► A center-tapped resistor is not always used, since it is less expensive to tap the electrical center of the filament winding on the power transformer instead (Fig. 3C). Here point P is the $+C$ and $-B$ terminal for this tube stage.

HEATER TYPE TUBES

Variations in voltage between the grid and the electron emitter may also be eliminated by using a cathode or electron emitter that is not connected to the heating source. A heater type

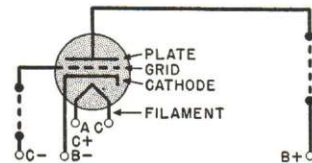

FIG. 4. The elements of a heater type tube.

tube has its filament surrounded by a sleeve coated with electron-emitting chemicals. This sleeve is the cathode, and emits electrons; the filament (whether fed with d.c. or a.c.) only furnishes heat to the cathode. Emission is kept constant by making the filament and cathode heavy enough to

hold an even temperature. The connections for such a tube are shown in Fig. 4. Since no a.c. is dropped in or applied to the indirectly heated cathode, there is no need for center-tapped resistors across the filament supply of these tubes. (Sometimes there is a center tap on the filament transformer. This lead is generally grounded to the chassis to reduce leakage and stray fields and thus further reduce the possibility of hum.)

Heater type tubes have replaced filament types almost altogether in radio receivers using a.c. power supplies. However, filament type tubes are still widely used in transmitters, in power packs, and in some output stages where a slight amount of hum does not matter.

FILAMENT CONNECTIONS

The tubes commonly used in a.c. operated radio receivers need filament voltages of 1.5, 2.5, 5, or 6.3 volts. These voltages are furnished by low-voltage windings on the power transformer.

Ordinarily, tubes needing the same filament voltage have their filaments wired in parallel and connected to the same filament winding on the power transformer, as shown in Fig. 5A. When circuit requirements make it necessary to separate filaments of tubes needing the same filament voltage, an extra winding will be provided on the power transformer secondary for the filaments which are to be

operated as a separate circuit (see Fig. 5B).

► If tubes with different filament voltage ratings are used in the same piece of radio equipment, separate filament secondary windings must be provided for each group, as shown in

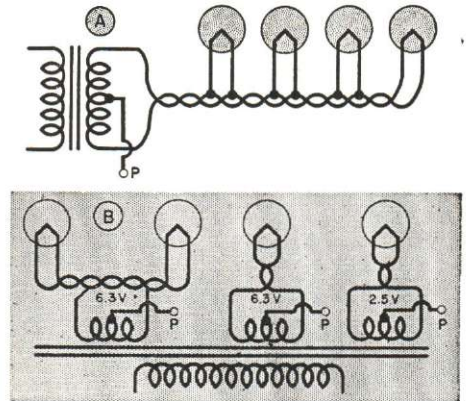

FIG. 5. Filaments must be connected according to their voltage and current needs.

Fig. 5B. A 2.5-volt tube, for example, cannot be operated from a 6.3-volt source, for the filament of the 2.5-volt tube will draw too much current and burn out almost at once. That's something to remember in your service work—*always be careful to operate a tube on the correct filament voltage.*

Circuits 5A and 5B may be used with either filament or heater type tubes. With filament tubes, the center tap P must be used as the $C+$ and $B-$ connection.

Obtaining D. C. from A. C.

You have learned that the filament can be supplied with a.c. directly if we use a cathode or indirectly heated type of tube, or use a tube with a heavy filament and make the proper

connections. But we must use d.c. for the plate and grid supply.

To operate the average radio receiver and amplifier properly, 110-volt, 60 c.p.s. power must be converted

to about 400 volts d.c. without an appreciable ripple.* Theoretically, you cannot take out all the ripple, but practically, you can make it so small that it produces no noticeable hum in the loudspeaker or other output device.

Fig. 6 shows how the power pack works. The 110 volts from the power line are first raised to a high a.c. voltage by a voltage step-up transformer. Next, the a.c. is passed

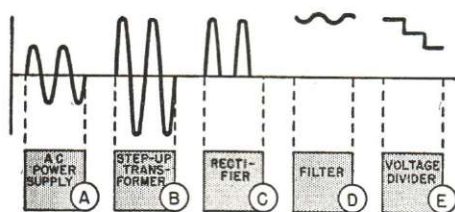

FIG. 6. We start with a.c. and get d.c.

through a device which we call a rectifier, which allows current to flow only in one direction. A tube is generally used. A rectifier tube produces pulsating direct current, varying from a peak (the largest) value to zero. To remove the variation, the electric power is passed through an electrical filter consisting of condensers and choke coils, which smooths out the variation or ripple, leaving pure d.c. Finally, the high d.c. supply voltage is divided as required. The changes from a.c. to divided d.c. are portrayed in Fig. 6. At A, B, C, D and E, the wave shape of the output voltage of each section is shown.

You know already that a transformer with more turns on its secondary than on its primary will step up a voltage according to its turns ratio. The power transformer in the average receiver steps up the power line voltage to as much as 350 or 400 volts—ample voltage for the tubes

* By ripple, we mean a small a.c. voltage superimposed on (combined with) the d.c.

used in radio receivers, amplifiers and control circuits. Of course, this a.c. voltage cannot be applied to the receiving tube electrodes, since the electrodes would be alternately positive and negative. We must rectify this a.c. supply into a d.c. voltage.

HALF-WAVE RECTIFIERS

Figs. 7A and 7B show the basic operation of a half-wave rectifier. In these circuits, the single resistor R_L represents all the tubes and circuits of a radio. We can use this representation because each tube draws current, and thus acts as a load on the power supply. The combined resistance of these various loads is equal to the supply voltage divided by the total current drawn. Our resistor R_L has the same ohmic value as the combined resistance of the tubes, and so has exactly the same effect as the tubes on the power supply. This resistor is called the load resistance.

Alternating voltage comes from transformer T . We want the voltage supplied to the load R_L always to have the polarity shown in Fig. 7A—in other words, we want to cut out the half cycles of the supply voltage which would reverse the polarity of the voltage across R_L .

We can cut out these unwanted half cycles of supply voltage by using

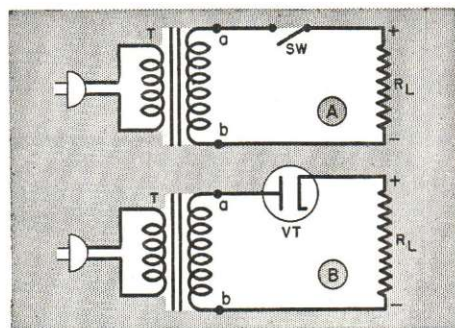

FIG. 7. A rectifier tube acts like an electronic switch.

some sort of switch that will close each time transformer terminal a is positive, and open each time this terminal is negative, with respect to terminal b . This can be a mechanical switch* (SW in Fig. 7A), but most radios use an electronic switch.

Fig. 7B shows a diode tube VT which acts as an electronic switch. When terminal a of the transformer becomes positive, the plate of the tube is made positive, and electrons flow from the cathode to the plate. (This corresponds to switch SW in Fig. 7A being closed.) The flow ceases when the voltage at terminal a drops to zero. During the next alternation the terminal polarity reverses, making the plate negative with respect to the cathode. Now no electrons flow to the plate, and our electronic switch is open.

If the voltage across terminals a and b changes at the rate of 60 cycles per second, the voltage across R_L as the result of the rectifying action of tube VT will be a series of half-wave pulses (60 every second), as shown in Fig. 8A.

This voltage across R_L is neither pure d.c. nor pure a.c., but rather a combination of both. (We started with pure a.c. and now have the desired d.c. mixed with some a.c.; this is called a pulsating d.c.) Analysis of this voltage by a special laboratory instrument called a harmonic analyzer will show us that it consists of the d.c. component (or part) shown in Fig. 8B, the 60-cycle ripple (or a.c. voltage) shown in C, and the ripples of higher frequency and smaller amplitude shown in D and E.

Now, we want only the pure d.c. component of this voltage shown in

* Later, when auto radios are studied, you will see how an electromechanical switch called a vibrator is sometimes used to close and open power supply circuits automatically.

Fig. 8B, because the a.c. components shown in C, D and E would cause hum if we applied them to our receiver. As you will learn later in this lesson, these a.c. components can be removed by sending the rectified voltage pulses shown in Fig. 8A through an a.c. filter. This removes everything but the pure d.c., which is then applied to load resistor R_L .

You can see that the d.c. component in Fig. 8B is not as great in magnitude as the peaks of the pulsating d.c. in Fig. 8A. This means that not all of the rectified voltage is available as

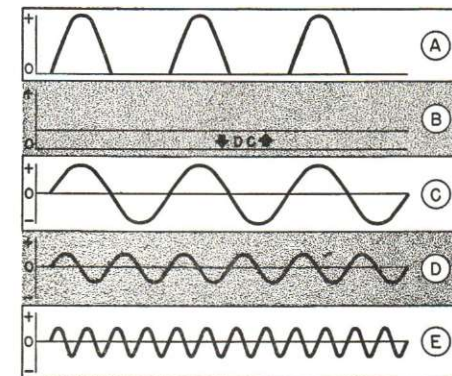

FIG. 8. The output of a half-wave rectifier.

d.c. for the load. Let's see how we can get more d.c. output.

FULL-WAVE RECTIFIERS

When we use the half-wave rectifier shown in Fig. 7, only one-half of the supply wave is rectified. (This does not mean that we are wasting power, for, when the tube is not passing current, none is taken from the source.) If we put both halves of the supply wave to work by using a full-wave rectifier, we can get a higher rectified voltage. In other words, we get a larger d.c. component from full-wave rectification than from half-wave.

Further, in the half-wave rectifier, the lowest ripple frequency is equal to

the frequency of the supply line, while the lowest ripple frequency of a full-wave rectifier is twice the frequency of the line (120 cycles for a 60-cycle line). This higher ripple frequency may be smoothed out with smaller, less expensive parts.

Full-wave rectification uses both halves of the a.c. cycle, as the name implies. By making a change in the transformer and by using a dual tube rectifier, we can make current from both halves of the cycle flow in only one direction through the load in our former half-wave rectifier circuit.

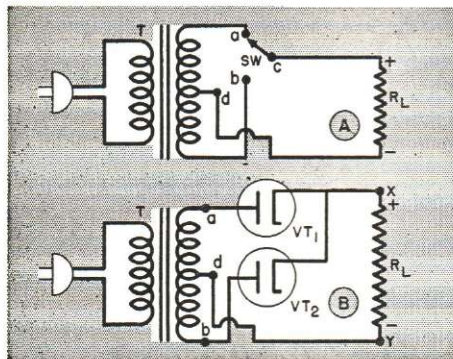

FIG. 9. A full-wave rectifier is a double switch.

The transformer change consists of providing the secondary with a center tap which is used as the reference terminal. When one end of the winding is positive with respect to this center tap, the other end will be negative, and vice versa.

Going back to our idea of a rectifier tube as an electronic switch, our full-wave rectifier circuit is really that shown in Fig. 9A. Here we have a switch arm *c* which throws to whichever transformer terminal (*a* or *b*) is positive with respect to center tap *d*. When *a* is positive with respect to center tap *d*, the switch closes *a-c* so the voltage between *a* and *d* is applied to the load.

When the a.c. cycle reverses, mak-

ing *a* negative and *b* positive, the switch changes connection and we apply voltage *b-d* to the load. Now let's substitute two tubes for the switch, as shown in Fig. 9B, and see how the circuit works.

When point *a* is positive with respect to *d*, electrons flow from the center tap *d* to load terminal *y*, to *x*, to the cathode of tube *VT₁*, across to the plate and to point *a*. The electrons cannot go from *d* to *b* because they cannot pass through *VT₂*, when point *b* is negative with respect to *d*. Therefore the path taken through *VT₁* is from *d*→*y*→*x*→cathode→plate→*a*. On the next half cycle, when *b* is positive with respect to *d*, the path is through tube *VT₂*—that is *d*→*y*→*x*→cathode→plate→*b*.

You see at once that the tubes alternate in passing electrons through the load *R_L*. Also, the actual voltage rectified is half the voltage across *a* and *b*. In other words, the a.c. voltage across the entire transformer secondary in Fig. 9B must be twice as

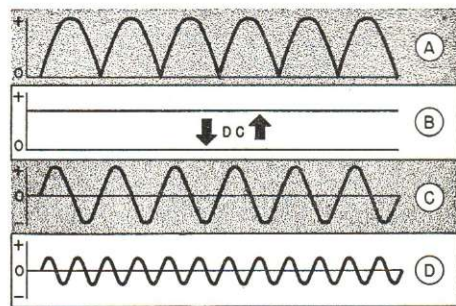

FIG. 10. The output of a full-wave rectifier.

much as in Fig. 7B to realize about the same peak rectified voltage, because only half of the total secondary is being used at a time.

The pulsating output current through the load has the wave form shown in Fig. 10A. Compare this with Fig. 8A and you will see that there are twice as many pulses, with

no gaps between pulses. This makes the d.c. average of this wave about twice as much as that of a half-rectified wave (compare Fig. 10B with 8B). Of course, we must get rid of the ripple frequencies shown in Figs. 10C and 10D before we can use this d.c. output for the load.

Full-wave rectifiers are so practical that they are almost universally used in radio receivers. Instead of two separate tubes as shown in Fig. 9B, a twin diode tube is generally used, as shown in Fig. 11. This tube has two separate diode rectifiers in a single glass or metal envelope. A rectifier tube of the cathode type is shown in Fig. 11A, while a filament type is shown in Fig. 11B. In filament types, the positive load terminal must connect to the filament. The connection may be made to either filament.*

(Perhaps you wonder why we connect directly to the filament instead of to a center tap on the filament winding. While it is true that the direct filament connection creates a certain amount of a.c. in the rectifier output, this is removed along with the ripple frequencies which are present in any rectifier output. The direct filament connection therefore does no harm.)

*The filament voltage serves no other purpose than to make the filament hot enough to emit electrons and does not affect the B supply voltage in any way. Neither does the B supply voltage have any effect on the filament voltage. The two circuits are quite independent and are simply joined together at one point. We want to impress on you the fact that there is no interaction between the circuits, for students (forgetting that a circuit must be complete before current can flow) often ask why the high d.c. voltage does not burn out the filament. As you can see, the d.c. is not applied across the two filament leads and hence cannot cause an excessive current to flow through the filament.

The two diode tube sections (or separate tubes, if they are used) should be "balanced"—that is, have the same emission characteristics. Furthermore, each diode should be supplied with the same amount of a.c. voltage to rectify. Both conditions make the

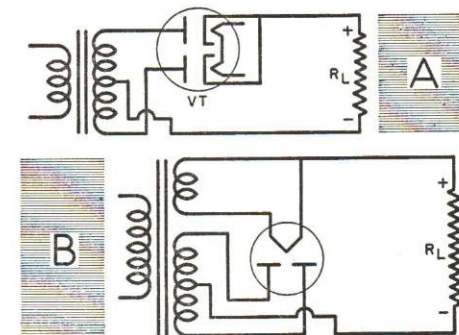

FIG. 11. Twin diode tubes are usually used for full-wave rectification.

filtering job easier. Should one tube pass much more current than the other, the output wave form will become more like that of the half-wave rectifier in Fig. 8A than that in Fig. 10A. In other words, the frequency of the main ripple will be cut in half; since the filter is not designed to suppress this lower frequency properly hum will be produced.

► The transformer is designed to supply approximately equal voltages to the diodes. Very little trouble can occur here. Usually an unbalance is caused by the emission of the two tube sections changing to unequal values. When you are servicing a power supply, check both sections of the rectifier tube in a tube tester and then compare the readings. If the tube sections are greatly unbalanced, you should install a new tube.

Taking Out The Ripple

As you have already seen, the output of a rectifier is made up of d.c. and a number of a.c. components. We want only the d.c. to pass through the load, so we must "filter out" the a.c. in some manner. A combination of an iron-core choke and a condenser is most widely used for this purpose. Let's see how they work.

THE L-C FILTER

Fig. 12A shows the power supply circuit we have studied so far. For simplicity, *S* is used to represent the transformer-rectifier section, supplying both a.c. and d.c. to load R_L . If we introduce a choke coil *L* in the circuit as shown in Fig. 12B, the d.c. and all the a.c. components must flow from the rectifier circuit through *L* and R_L . Both a.c. and d.c. voltage drops will exist across choke coil *L*.

Now, you learned in an earlier lesson that a choke coil may have low d.c. resistance and high a.c. reactance. Because of its low ohmic resistance, negligible d.c. voltage will be lost in *L*, and most of the d.c. supplied from the rectifier will be applied to the load R_L . But if the reactance of choke *L* is made large compared to the resistance of R_L , most of the a.c. voltage will be dropped in the choke. If we select an inductance which will drop a large amount of the fundamental a.c. frequency, even greater voltage drops will exist for the higher frequency components—because the reactance of the choke will increase with frequency.

We could make the inductance of the choke coil so large that only a negligible amount of ripple voltage would appear across the load, but such a coil would be much too expensive and bulky. Instead, we can use an easily obtained coil and introduce a

condenser into the circuit, as shown in Fig. 12C. The condenser *C* is chosen so that its reactance is low compared to the resistance of R_L , so it acts as an a.c. short circuit across the load. As the a.c. circuit in *B* includes the reactance of *L* and resistance of R_L , the low-reactance condenser in *C* also reduces the total a.c. circuit impedance, causing a greater a.c. flow through the choke and thus increasing the ripple voltage drop across the choke.

As far as a.c. is concerned, you can think of this circuit as containing a low-reactance condenser in series with the high-reactance choke. Since the same current flows through both, there will be a large voltage drop across the high-reactance choke, and just a small voltage across the condenser. As the load R_L is in parallel with the condenser, it also has only a small a.c. voltage across it. The filtering is just as good with this arrangement as if the choke inductance had been increased.

Another Explanation. There is another way of looking at a choke coil-condenser section such as this. The action of the coil is very simple. As you know, it always attempts to prevent a change of current—by stor-

ing energy in the magnetic field when the current is increasing, and releasing energy when the current decreases. It tries to hold the current constant, so the effect of the coil by itself is to "smooth out" the current variations.

The condenser charges as the current pulse from the rectifier increases. When the pulse passes its peak and starts to decrease, the condenser discharges into the circuit. This means the condenser helps make up for the drop in current from the rectifier. Thus, like the coil, the condenser smooths out current variations; the combination of the coil and condenser naturally does this smoothing out better than either of them alone. The effect is that of cutting off the current peaks and filling in the valleys, so only an average d.c. current remains. As these *L-C* filters forcibly remove the a.c. component, they are known as "brute force" filters.

Summary. To sum up, the d.c. component of the rectifier output is divided between the *choke d.c. resistance* and the *load resistance*. Since the choke coil has a low d.c. resistance, most of the d.c. voltage appears across the load where it is wanted.

The a.c. components are divided between the *high choke reactance* and the *low condenser reactance*, so practically all the a.c. is dropped in the choke coil, leaving little a.c. across the condenser. Since the condenser and load are in parallel, this means that there will be little a.c. ripple across the load to cause hum.

► There is another important point we want you to see clearly. In Fig. 12C we have a series a.c. circuit consisting of the source *S*, *L* and *C*. As in any series circuit, the current will be the same at any point in the circuit. Therefore, if we move *L* to the position shown in Fig. 12D, the same current will flow through it as in Fig.

12C. If the same current flows through *L*, the same amount of voltage will be dropped across it and the change in position of the choke does not affect the a.c. voltage division. Hence, it does not matter whether the choke is placed in the negative side or in the positive side of the filter circuit; the same amount of filtering is obtained in either case.

MULTI-SECTION FILTERS

As you've just learned, a filter is a voltage divider. As far as the ripple is concerned, the divider consists of inductive reactance X_L and capacitive reactance X_C . The voltage divides in almost exact proportion to the reactance values, so the ripple reduction factor (ripple input divided by ripple output) equals $X_L \div X_C$.

Now suppose that we have one filter which reduces the ripple 100 times, or from 100 volts to 1 volt. This means that the reactance of X_L is 100 times as great as that of X_C . Now suppose we feed this remaining 1-volt ripple into a second filter using the same values of *L* and *C* as the first. Again the filter will reduce the ripple fed to it 100 times—from 1 volt to .01 volt. The *total* reduction is now from 100 volts to .01 volt, which is $100 \div .01$ or 10,000 times.

Clearly, the reduction obtained from two filter sections is their reduction factor product (100×100 is 10,000). To get a reduction of 10,000 times in a single filter, the choke reactance would have to be 10,000 times the condenser reactance and the expense would be prohibitive. But we can get such a reduction easily, using inexpensive parts of reasonable size, just by using two filter sections as shown in Fig. 13. Filters hooked up this way are called "cascade" filters.

Cascade filters are almost always used in transmitter power packs, where

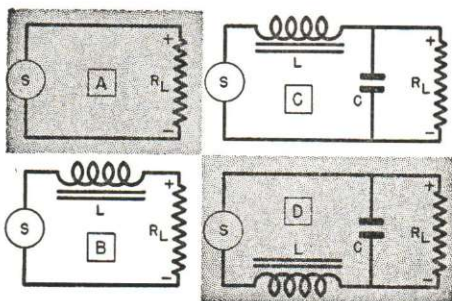

FIG. 12. The choke input filter is formed by using a choke and condenser.

fewer sections would mean very expensive parts. Sometimes as many as three sections in cascade are used in transmitters, high-fidelity amplifiers and special equipment. In home receivers, a single-section filter, using modern high-capacity electrolytic condensers and a good choke coil, is satisfactory in most cases.

TUNED FILTERS

You've learned that the larger the reactance L is, compared to C , for the

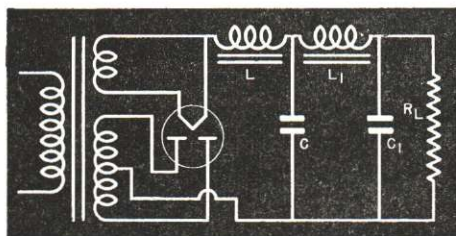

FIG. 13. A cascade filter.

ripple frequency we wish to suppress, the greater will be the ripple reduction. Now, a parallel resonant circuit at resonance has a greater resistance than the reactance of either the inductance or capacity used in it. We can combine these facts to produce a more efficient filter by using a circuit like that shown in Fig. 14A. Here L has been replaced by a parallel resonant circuit L_1-C_1 through which the d.c. and all a.c. components must pass.

When L_1 and C_1 are tuned to a definite frequency, this circuit will offer a very large impedance to current of that frequency, much larger than L_1 alone. As a result, when the a.c. ripple divides between the resonant circuit and C_2 , most of the a.c. is dropped across the tuned circuit because of its high impedance at the ripple frequency.

For d.c., the resistance of the resonant circuit is simply the resistance of the wire with which L_1 is wound. This

resistance is low, so most of the d.c. appears as a charge across C_2 , from which it is passed on through the next filter section to the load.

A fairly large value of L_1 should be chosen so the capacity of C_1 will be small. At frequencies above resonance, the condenser reactance is lower than that of the choke, and the higher ripple frequencies are by-passed around the choke. By keeping the capacity of C_1 small, this effect is reduced, but it is desirable to have another filter section L_2-C_2 to be sure to eliminate the higher ripple frequencies.

Now, a series resonant circuit has a low impedance at the resonant frequency. In a filter, the shunting condenser should have low reactance. This suggests that, instead of a parallel resonant circuit in place of L , we might use a series resonant L-C circuit in place of C . Such a circuit is shown in Fig. 14B.

When L_2 and C_1 are in resonance with the lowest ripple frequency, they offer very little opposition to that component. Therefore, when the a.c. ripple divides between L_1 and the resonant circuit, most of the ripple is dropped across L_1 . This circuit is effective at the frequency for which it is designed (the lowest ripple frequency), but at higher frequencies, resonance does not occur and the circuit acts like an inductance. Thus, all component ripple voltages higher in frequency divide between L_1 and L_2 , creating a high-frequency ripple across L_2 . It is for this reason that a tuned filter must always be followed by another untuned section (L_2-C_2 in Fig. 14B).

For 60-cycle, half-wave rectifiers, the circuit L_1-C_1 in Fig. 14A or L_2-C_1 in Fig. 14B would be made to resonate to 60 c.p.s.; for a full-wave rectifier, these circuits should resonate to 120

c.p.s. As you've learned, these are the lowest ripple frequencies found in these rectifiers.

You may find a radio receiver or amplifier, using a tuned filter, which has a hum that seems to defy correction. This is often caused by a change in the inductance value of the iron-core choke (shift in the laminations from rough handling), or perhaps the filter circuit is not quite tuned to the proper frequency. To remedy this, try varying C_1 . Small condensers added in parallel will gradually increase the capacity. Should the condenser already be too large, use a smaller one in place of it and add others in parallel until minimum hum is obtained.

If condensers C_2 and C_3 in a power supply like that shown in Fig. 14A are small paper condensers, quite often the best way to make repairs is to eliminate the tuned filter altogether by removing its tuning condenser C_1 . Then you must substitute high-capacity electrolytic condensers for the small paper filter condensers. For the circuit of Fig. 14B, remove L_2 and replace C_1 and C_2 with higher capacity electrolytics. The results with the new filters will, in many cases, be better than those with the original tuned filters in these cases.

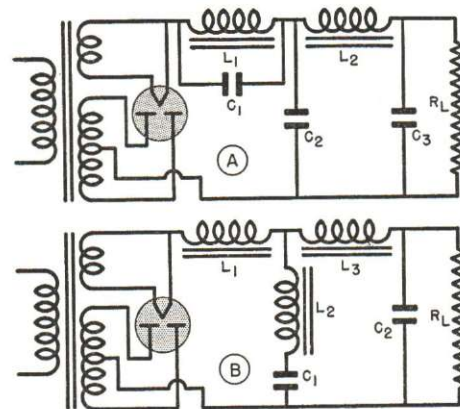

FIG. 14. Examples of tuned filters.

In each of the filters we have so far studied, the output of the rectifier has been fed into a choke. This is known as a "choke input type" filter. Voltage division has been used to cause the d.c. component of the rectifier output to appear across the load, and the energy in the a.c. components has been deliberately wasted. Now we will see how some of this energy may be captured and put to use.

CONDENSER INPUT FILTERS

Suppose we connect a condenser C across R_L in the half-wave rectifier

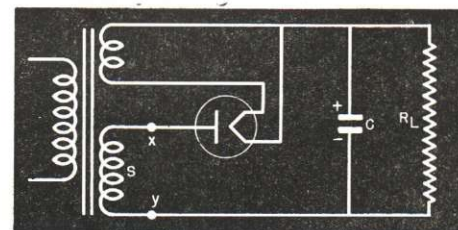

FIG. 15. A condenser alone forms a partial filter, delivering a much higher d.c. voltage providing the current demand is low.

circuit shown in Fig. 15. What will happen? As before, the rectifier will try to produce an output wave form like that shown in Fig. 16A. Notice we say "try"—actually something entirely different will be produced.

When the a.c. voltage makes terminal x positive with respect to terminal y of transformer secondary S , the tube will pass current. As the tube current increases, condenser C is charged up until the condenser voltage builds up approximately to the peak* of the a.c. voltage.

After reaching its peak value, the a.c. voltage begins to decrease and the plate current drops. Now the con-

* The peak value is the maximum positive or negative value of an a.c. cycle. It is 1.41 times the r.m.s. value which is read by an a.c. voltmeter. Thus, the peak is 423 volts when the r.m.s. value is 300 volts.

denser is charged to a high voltage. This charge cannot escape quickly, so when the source voltage drops, it leaves the condenser voltage higher than the source voltage. The condenser voltage is in series with the supply voltage in winding *S*, between the tube cathode and plate, and (because of the polarity of the condenser) opposes this supply voltage. As soon as the condenser voltage is greater than the supply voltage, the plate of the tube is made negative. This cuts off the current flow through the tube.

The electrons stored in the condenser now leak off through the load R_L . The condenser thus acts as a source of current for the load, and gradually discharges in the process. When the a.c. voltage again becomes positive, the tube conducts as soon as the supply voltage becomes higher than the voltage of the partly discharged condenser. The condenser is then charged again to the peak voltage of the supply, and the cycle already described repeats.

This action is shown in Fig. 16*B*, in which the heavy line shows the voltage impressed across the load. As the a.c. voltage builds up from zero to the peak value, the condenser charges. When the a.c. decreases from the peak toward zero, it drops below the condenser voltage, and the tube no longer conducts. Gradual discharge of the condenser brings its voltage down by the time the next pulse rises from zero. Then, the condenser is recharged and current comes from the tube. As the source voltage goes from the peak toward zero, the condenser again takes over.

The important thing for you to understand is that the condenser acts as a source for the load for a longer part of the cycle than does the tube.

The gradual reduction in voltage across the condenser, shown by the

slanting lines between the peaks, is caused by the discharge of the condenser through load R_L . If the load resistance is made lower in ohmic value, the condenser will lose its charge and voltage more rapidly. When the condenser is charging, only the tube resistance and the transformer impedance limit the charging current, so the condenser reaches full charge almost at once.

The time in seconds it takes to drain a condenser of 63% of its original

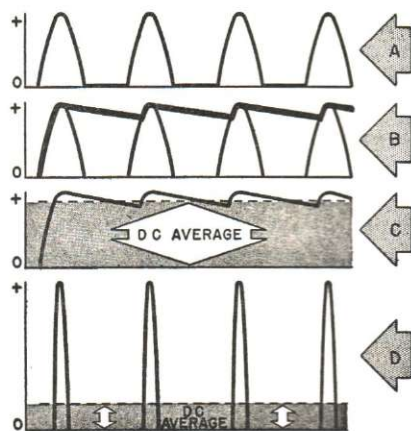

FIG. 16. The rectifier output when using a condenser input filter.

charge equals the condenser capacity in mfd. multiplied by the load resistance in megohms. Thus, if R_L in Fig. 15 has a resistance of 5000 ohms (.005 megohm) and C a capacity of 20 mfd., it will take $.005 \times 20$ or 1/10 of a second to drain the condenser. But the condenser is being recharged 60 times a second (if the power line is a 60-cycle supply) and therefore never fully discharges. The wave form of the voltage across the condenser is shown in Fig. 16*C*. This wave consists of a d.c. component and small a.c. ripple components, just like other pulsating currents. But the d.c. average is almost equal to the *peak* of the a.c. cycle—instead of being only

about 3/10 of this value as it was for the ordinary half-wave rectifier shown in Fig. 7*B*. Clearly, the use of this condenser gives a much higher d.c. output for the same a.c. voltage input.

Furthermore, the a.c. ripple is far less, so the condenser by itself is a partial filter. A regular L-C filter is used between the condenser and load to remove the remaining ripple. A typical power pack using this filter system is shown in Fig. 17. This filter is known as the "condenser input" type, because the tube output goes to C_1 first. You will find condenser input filters in most radio receivers.

► But there is a price to pay for the increased d.c. output and lowered ripple obtained from the condenser input filter. The rectifier tube only supplies current for a small period of time, yet this current, by charging the condenser, must operate the receiver continuously. This means the current peaks must be very high and sharp.

The current into the condenser and load from the tube is shown in Fig. 16*D*. The average d.c. is low, because the rectified current pulses exist for short time periods, yet it must equal the current required by the load.

Therefore, the rectifier tube works very hard for short periods of time. It is important that the load be kept at a reasonable value; otherwise, this terrific rush of current can damage the tube. The tube must be rated for not only the average current but also this peak current.

Where the load resistance is so low that the condenser discharges considerably, the peak current required may be too high for any standard tube. If so, a choke input filter must be used. You will find choke input filters in the power supplies of transmitters, in many public address systems, and in some radio receivers where high power is required.

PRACTICAL FILTER FACTS

The performances of the two main types of filters—choke input and condenser input—are most easily compared by means of curves. Fig. 18 shows a family of curves for a type 5V4G tube using an input filter condenser.

These curves show you how the voltage at the *input* of the filter varies with load current for different input capacitances. (The *output* of the filter will be equal to the input to the filter minus the drop in the filter choke. Since this drop depends on

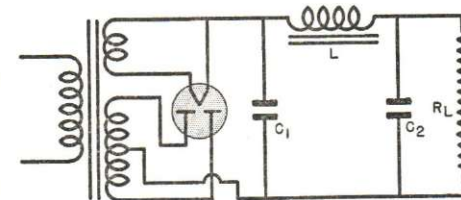

FIG. 17. A complete condenser input filter.

the d.c. resistance of the choke, and therefore will probably be different for every filter, the best way to compare performances of two different filters is to measure their *input* voltages. This is what we do in Figs. 18 and 19.)

To use the graph in Fig. 18, locate the curve you want. The one at the top marked 400 RMS Volts Per Plate, $C = 8$ MFD, will do as an example. 400 RMS Volts Per Plate means that this curve was made with 400 volts a.c. applied to each plate of the full-wave rectifier tube. The input condenser has a value of 8 mfd., shown by the notation $C = 8$ MFD. Now let us see how much input voltage to the filter is obtained when the load is 40 ma. Locate 40 ma. at the bottom of the graph, move straight up to the curve and then straight over to the left of the graph. This brings us to about 538 volts, the input voltage to

the filter when 40 ma. are drawn by the load.

We started with 400 volts and we are getting over 500! But the 400 volts is an r.m.s. value, so the a.c. *peak* is about 564 volts. Our value of 538 volts d.c. is thus close to the peak value.

Using the same curve, you will find the input voltage drops to 490 volts at a current of 120 ma. This shows that "loading" the circuit (increasing the load current) reduces the input voltage considerably. This drop is caused mostly by the fact that the condenser had to lose a great deal of charge to supply the higher current. If a smaller input condenser is used, the drop with increased load current becomes even greater (as shown by the curve marked 4 mfd.), because the condenser loses its charge even more rapidly.

► Now let's use the curves in Fig. 19 to compare the effect of load current changes on the filter input voltage for both choke and condenser input. The condenser curves are the solid lines; the choke curves are dotted.

You see at once that the d.c. voltage at the input of the filter is considerably less for choke input than for condenser input. This is shown by the fact that the condenser input curves for a definite a.c. plate voltage are higher upon the graph. Thus, at a current of 100 ma., we can get about 455 volts d.c. from a 400-volt a.c. input to a condenser input filter, while we can get only about 330 volts when this same 400 volts a.c. is used with a choke input filter.

To put this another way—with a condenser input filter, 400 volts a.c. must be applied to each rectifier plate to obtain 400 volts d.c. with a load of 180 ma. If you use a choke input, you will need about 500 volts a.c. per plate to get the same results. Thus,

for a fixed d.c. filter input, a choke input filter needs a transformer capable of producing a higher a.c. rectifier plate voltage than is needed with a condenser input filter.

► Should the input filter condenser open up (lose its capacity), the d.c. voltage would be greatly reduced, because the circuit then acts effectively as a choke input filter (as if the condenser were not there.)

► The condenser input filter thus has advantage over the choke input type. However, while the voltage drops rapidly as the load current increases in a condenser input filter, it changes very little when a choke input is used. This change in voltage as the load current changes is called regulation.* The better regulation obtained with a choke input makes this arrangement especially valuable when the load current goes through wide variations. Such variations occur particularly in transmitters and in high-power audio amplifiers used in some receivers and in public address systems.

SWINGING CHOKE

The dotted line curves shown in Fig. 19 were made with an input choke having a definite inductance in henrys. If some other value choke is used, the shape of the curve will be approximately the same, but it will be higher up on the graph if the inductance is less, and lower (reducing the filter input voltage) if its inductance is greater.

In other words, the smaller the value of the input choke in henrys, the greater the input voltage to the filter, because this permits the following condenser to act more like an input condenser. As you've just learned, a condenser input filter always has a

* Briefly, regulation is the change in voltage which occurs when the load current changes. The regulation is said to be good when the change in voltage is small.

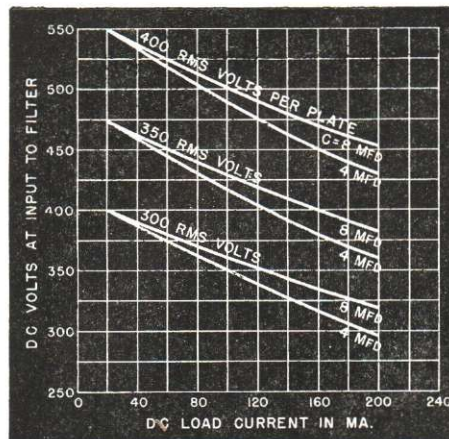

FIG. 18. These curves show that larger input filter condensers give higher output voltages, for large load currents.

higher input voltage than a choke input filter for the same rectifier plate voltage.

Now, as you learned a short while ago, the *output* of a filter (that is, the voltage furnished to the load) equals the *input* to the filter minus the d.c. voltage drop within the filter. Since the resistance of the filter is constant, this d.c. voltage drop in the filter naturally rises as more current is drawn through the filter. Also, there are d.c. voltage drops in the rectifier tube and transformer. This means that the output voltage of an ordinary filter will drop as more current is drawn by the load.

But if the input choke inductance can be made variable, so it can be decreased when the load current increases, the input voltage will rise and make up for the d.c. drops inside the power pack. Thus, the *output* voltage will remain almost constant.

By using a choke of special design, we can obtain a variable choke inductance. The air gap of this choke is purposely made small so that the core may be easily saturated. As you learned from your study of iron-core

coils, saturation occurs when increases in current no longer cause increases in flux. When this condition is approached, the inductance of the choke decreases—which is just what we want to maintain constant output voltage.

Thus, by designing the choke so it will approach core saturation as the load current increases, we get a variable input choke inductance which gives us a more constant load voltage. Since the inductance of such a choke increases and decreases, it is called a *swinging choke*. You won't often find one in radio receivers, but they are common in public address systems, transmitters and electronic control devices.

Of course, the swinging choke gives a variable amount of ripple reduction, so it is used only as an input choke. Another standard filter section is always used after this choke, forming a circuit like Fig. 13.

► Saturation will occur in any iron-core choke if d.c. in excess of its rated value flows through it. Leakage in an output filter condenser (such as C_2 in

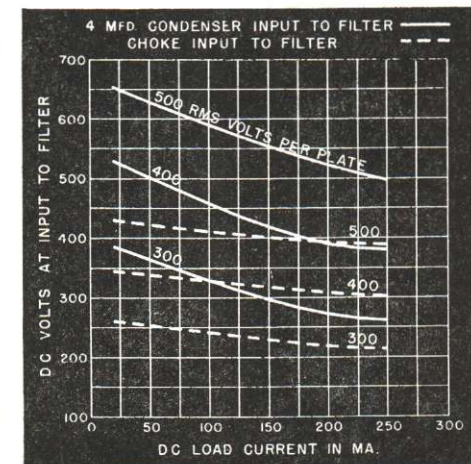

FIG. 19. Comparing the output of choke and condenser input filters, we find the condenser input type delivers a higher d.c. voltage with poorer regulation.

Fig. 17) can let enough current flow through filter choke L to saturate it. The reduced inductance of L destroys

the filter action and permits the ripple voltage to pass on to the load, causing hum.

Dividing the Voltage

The high d.c. voltage delivered by the power pack filter is used to supply B and C voltages to various tubes. Often these tubes require different plate, screen grid, suppressor grid, cathode and other voltages. Let us now see how these voltages are obtained from the output of the filter.

D.C. Circuit Laws to Remember. In order to understand d.c. voltage distribution circuits, you must remember these important circuit facts:

- 1. The currents flowing to a terminal equal the currents flowing away from that terminal (Kirchhoff's Current Law).
- 2. In *any complete* circuit, the supply voltage equals the sum of all the voltage drops (Kirchhoff's Voltage Law).
- 3. The voltage drop across any device equals the current times the resistance (Ohm's Law).
- 4. The polarity of a voltage drop can be determined by remembering that the terminal of a device at which electrons enter is negative with respect to the terminal at which they leave.
- 5. Points connected together by a resistor, coil, or wire through which d.c. current is not flowing are at the same d.c. potential—there is no voltage drop between them.
- 6. "Voltage" always means the voltage *difference* between two points. Thus, when you speak of plate voltage you mean the voltage difference between the plate and cathode, and when you speak of grid voltage you mean the voltage difference between the grid and cathode.

- 7. A point can be negative with respect to one point and at the same time be positive with respect to some other. Thus, in a tube circuit, the cathode is negative with respect to the plate and, at the same time, positive with respect to the control grid.
- 8. If two points are grounded, there is no d.c. voltage difference between them. They act as if they were wired together directly.

BASIC DIVIDERS

If the power supply furnishes exactly the right amount of voltage for the load, we can connect the load directly across the d.c. supply terminals. Since the voltage is correct, the right current will flow. We need only to be sure the supply can furnish all the current required.

But in any radio device there will be many loads requiring only fractional parts of the supply voltage, and not all of these loads need the same amount of voltage. How can we divide the power supply voltage to meet all requirements?

Series Voltage Drops. If the power source furnishes more voltage than is needed by the load, the correct load voltage may be obtained by placing a resistor between the power supply and load, as shown in Fig. 20A. The supply voltage will divide between the load resistor R_L and the voltage-dropping resistor R_1 . If we choose the correct value of R_1 , just enough voltage will be dropped across it to leave the right amount of voltage for R_L . We can figure the value

of R_1 by using Ohm's Law, which says that $R_1 = V \div I$. Here I is the current which is to flow through the load * and V is the excess voltage we wish to drop across R_1 .

Remember—the series dropping resistor may be placed on either side of the load or, if necessary, we can split the series resistor, placing part on each side of the load. The same current flows through each part of a series circuit, so the same voltage drops will occur as long as the total resistance is the same.

► Suppose we connect a number of similar loads in parallel, as in Fig. 20B. Now the current through R_1 is the *sum* of the load currents, so the value of R_1 must be figured by dividing the voltage drop which is to occur

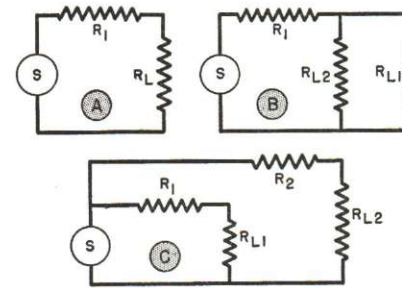

FIG. 20. Series resistors used to drop the voltage.

across it by the sum of the load currents. This connection can be used when the *voltages* required by the loads are the same—even though different currents may be required.

► When *different voltages* are needed—for example, to supply a plate and a screen grid—the method shown in Fig. 20C may be used. Resistors R_1 and R_2 are figured for the load each is used with.

Both Fig. 20B and 20C can be extended to any number of loads. This voltage dividing method is known as

* Since this is a series circuit, the load current also flows through R_1 .

"series voltage dropping," because the dropping resistor is in series and is the only extra part used.

Bleeders. Frequently, the load current varies over wide limits. This produces a varying voltage drop across the series resistor, thus changing the division of voltage between the resistor and the load. We can reduce this variation or eliminate it entirely by drawing off or, as technicians say, "bleeding" extra current through the series resistor. A resistor known as a "bleeder" is connected across the load to draw the extra current.

The circuit looks like Fig. 20B, in which R_{L2} will act as a bleeder across R_{L1} . By choosing bleeder R_{L2} so it draws far more current than does R_{L1} , the voltage drop across R_1 will be caused mainly by the bleeder current flowing through it. Then, small variations in the value of R_{L1} can cause only very little change in the total current through R_1 , so the voltage drop across R_1 remains practically constant. This means the voltage across R_{L1} is practically constant no matter what current R_{L1} draws (within limits, of course), so the voltage regulation at R_{L1} is very good. The bleeder resistor must be designed to draw a great deal more current than the variations expected in the load current, yet not draw more current than the supply can furnish. Of course, if the load current does not change or the change does not matter, no bleeder is needed—a series dropping resistor is sufficient.

Voltage Dividers. Instead of using a separate series resistor and a separate bleeder resistor, we can use a single resistor, tapped to form a voltage divider as shown in Fig. 21A. Section R_1 is the series section, while R_2 is the bleeder section.

Additional taps may be provided on R_1 to supply various loads (see Fig.

21B). Here the bleeder current I_B through bleeder resistor R_2 flows through all sections of the voltage divider. In section R_4 , currents $I_B + I_3$ flow; in R_3 , currents $I_B + I_3 + I_2$ flow, and in R_1 , we have $I_B + I_3 + I_2 + I_1$ flowing. In each section, the value of the resistor in ohms equals the voltage across the resistor divided by the current flowing through it.

All possible combinations of loads, series dropping resistors and bleeders have not been shown, but Figs. 20 and 21 show the basic methods of voltage division. Reference to them will help you solve any power supply voltage divider network, provided you understand Kirchhoff's Current and Voltage Laws.

WE HAVE STRESSED THESE LAWS BEFORE, BUT THEY ARE SO IMPORTANT IN PRACTICAL RADIO WORK THAT WE REPEAT THEM AGAIN:

1. The sum of the currents flowing to a point is equal to the current flowing away from that point. Thus, in Fig. 21B, $I_B + I_3$ equals the current flowing through R_4 .

2. The sum of the voltage drops in a complete circuit equals the source voltage which produced them. For example, in Fig. 21A the supply voltage divides between R_1 and the parallel resistors R_2 and R_L . The same voltage exists across R_2 and R_L , and this voltage added to that across R_1 equals the source voltage S . Similarly, in Fig. 21B, the sum of the voltages across R_1 and R_{L1} equals the source voltage. Also, the sum of the voltages across R_{L2} , R_3 , and R_1 equals the source, and so on.

PRACTICAL DIVIDER CIRCUITS

Fig. 22 gives an example of series dropping resistors in a practical cir-

cuit. Plate current flowing through resistor R causes a voltage drop across R which reduces the supply voltage to the correct amount for the plate. In the same way, screen current through R_1 causes a voltage drop across this resistor which reduces the voltage to the desired screen value. (The resistance of each resistor, as you know, is calculated by dividing the required voltage drop by the electrode current through the resistor.)

► The cathode current (which is the sum of the plate and screen currents)

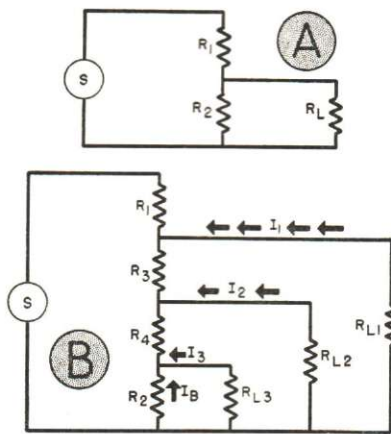

FIG. 21. Examples of voltage dividers.

flows through R_2 , dropping only a few volts across it because of the low ohmic value of R_2 . The polarity* of the voltage drop is as shown. Since the grid connects to the negative side of the drop and the cathode to the positive side, this voltage is between the grid and cathode, and so biases the tube. For this reason, R_2 is known as the cathode resistor, or as a C bias resistor, or simply as a bias resistor.

* To determine the polarity of a voltage drop, remember: THE END OF A RESISTOR (OR OTHER PART) AT WHICH ELECTRONS ENTER IS ALWAYS NEGATIVE WITH RESPECT TO THE END AT WHICH THEY LEAVE. Tubes serve as signposts for electron direction, since electrons always move from cathode to plate.

► If a number of tubes require the same screen voltages, the screens are joined together and the combined screen currents flow through R_1 . Since the combined currents through R_1 will now be greater, the ohmic value of R_1 must be decreased if the same screen voltage is to be maintained. The value of R_1 in ohms will be equal to the required voltage drop divided by the combined currents flowing through it.

► Where several tubes require equal C voltages, the cathodes could be joined together. The ohmic value of R_2 would then equal the desired C voltage divided by the combined cathode currents. Ordinarily, however, separate C bias resistors are used for each tube to prevent a possible variation in the current of one tube from affecting the bias of the others.

► To produce equal plate voltages for several tubes, we connect the plate supply circuits in parallel. Resistor

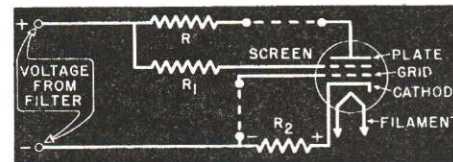

FIG. 22. A practical example showing series voltage-dropping resistors.

R is then figured by dividing the voltage drop required across R by the sum of the plate currents which flow through it. Often the voltage from the power supply is correct for the tube plates; then resistor R is not needed.

► If there are other tubes which do not require the same plate, screen and grid voltages, each of these tubes will have its own plate, screen and bias resistors. Even where several tubes use the same voltages, each one may have its own series resistor to prevent variations in one tube from affecting

the operating voltages of the others. ► Fig. 23 shows a typical bleeder circuit. Screen grid voltage reduction is produced by R_1 , which carries both the bleeder current drawn by R_3 and the screen grid current of the tube. The bleeder serves to stabilize or hold steady the screen grid voltage. Should the bleeder open, however, only the screen grid current would flow through R_1 , so its voltage drop would be less and more

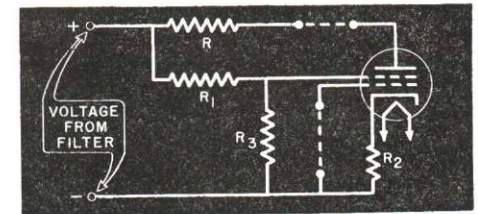

FIG. 23. A typical bleeder circuit.

voltage would be applied to the screen grid.

► A practical application of the voltage divider is shown in Fig. 24. Here, resistor R_2 is the bleeder. Series resistor R_3 provides the correct screen voltage, and the C bias voltage is produced across R_1 . Notice that both point 2 on the voltage divider and the cathode of the tube are grounded. The cathode and bleeder current electrons come from the minus supply terminal and flow through R_1 to point 2. Here they divide, the cathode electrons flowing through the chassis to the cathode, and the bleeder electrons continuing on through R_2 .

► Fig. 25 shows three common ways of getting bias voltage from the power pack. In Fig. 25A, resistors R_1 and R_2 (this may be a single tapped resistor) are placed in the power supply B—lead. Their action is similar to that of R_1 in Fig. 24, except that the cathode currents of all the tubes now flow through the resistors. Grids of tubes which need the full voltage for

bias are connected to C— while grids of tubes needing less bias are connected to C—.

You recall that a d.c. voltage drop exists across the choke and that the choke can be in the negative side of the circuit. Fig. 25B shows how we can use this drop to supply bias. Here, the drop across the inductance is higher than needed for bias, so the inductance is tapped. This is common practice when the speaker field* furnishes the filter inductance, as the drop may be 100 volts or so and the

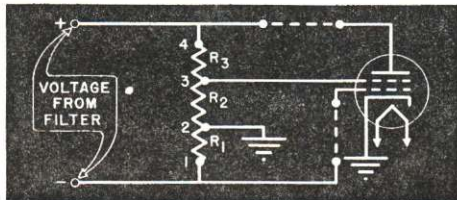

FIG. 24. A complete voltage divider.

required bias is usually 50 volts or less. This scheme is mostly used for power output tube bias.

Another way of using the voltage drop across the inductance is shown in Fig. 25C. Here a voltage divider is arranged across the inductance, with the resistances figured to give the desired voltage between B— and each tap. Since no current is taken by grid circuits, these resistors can be high values—in fact, they must be to prevent the resistors from interfering with the action of the inductance.

*The speaker field is a large inductance, requiring a d.c. current flow to establish a fixed magnetic field for proper loudspeaker operation. Since it has sufficient inductance, it can be used as the choke coil in a filter. The normal d.c. current of the set then provides the necessary field excitation. The d.c. resistance of a field is higher than that of the average choke coil, but proper power transformer design makes up for the extra d.c. voltage drop. The method described here makes use of this drop for bias purposes, so the single part is used as a speaker field, a choke coil and a source of bias.

VOLTAGE REGULATOR TUBES

Sometimes the voltage must be held very closely to the design value. Bleeder resistors are not perfect—in order to hold the voltage within small limits, the bleeder must draw a current many times higher than the possible variations drawn by the load. Often the power supply cannot furnish such high currents.

Further, if a line voltage change makes the power pack output change, the bleeder is helpless. As you can readily see by examining any of the bleeder circuits shown, the voltage across the bleeder will rise or fall as the source voltage rises or falls.

For these reasons, a voltage regulator tube (Fig. 26) is better than a bleeder for keeping voltage constant. This regulator tube *VR* is a gas-filled tube without a filament. When suf-

ficient voltage is applied to the tube, the gas ionizes and becomes conductive.

Unlike a bleeder, this tube does not have constant resistance. Its internal resistance depends upon the number of gas ions between the elements of the tube. When the voltage from the filter rises, the number of ions increases; the tube resistance drops, and the tube draws more current. When the voltage drops, the ionization is less; the tube resistance rises, and the current flow drops.

This means that a rise in the filter voltage will cause an increased current flow through *VR*, which in turn means a larger drop across *R*, as this current flows through *R*.

This drop across *R* automatically compensates for the increase in source voltage, so the voltage applied to tube *VT₁* remains very nearly constant. Similarly, when the load current decreases, the *IR* drop decreases and the voltage across *VR* increases. This causes a sharply increased current through *VR*, restoring the drop across

R to about its original value.

Should the opposite condition occur, then *VR* draws much less current, allowing the voltage to rise.

With a resistor *R* of proper size, this regulating circuit will keep the

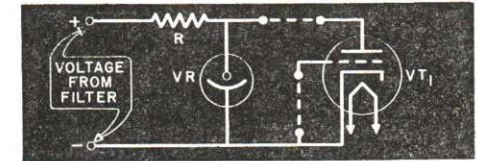

FIG. 26. Using a voltage regulator tube.

voltage supplied to *VT₁* from varying more than 1 or 2 volts under normal circumstances. The current taken by the *VR* tube ranges from a few ma. to about 30 ma., which is a reasonably small amount of current.

Voltage regulator tubes rated at 75, 90 and 150 volts are available, known as the *VR75*, *VR90* and *VR150* types. By using several of these tubes in series, or by using a voltage divider across a tube, higher and lower voltages can be controlled.

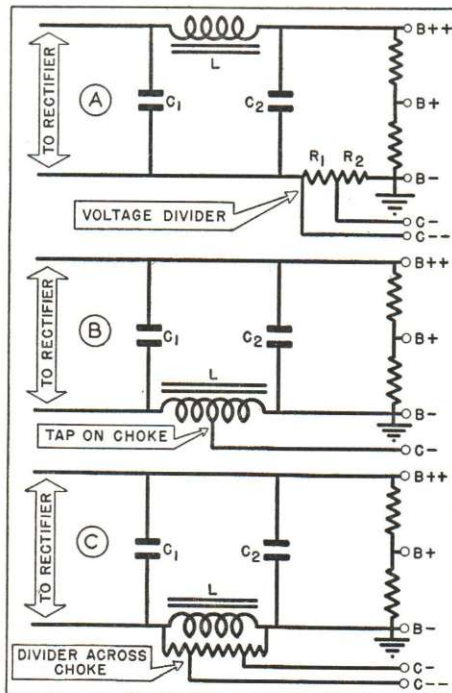

FIG. 25. Three ways of getting bias from the power pack.

Facts About Rectifier Tubes

Not every radio receiver or amplifier uses the same type of rectifier tube. Just as tube manufacturers make many tubes with different characteristics which can be used for detectors, amplifiers and power output purposes, so do they make many types of rectifier tubes from which the radio designer can choose the one best suited to a particular power supply.

VACUUM RECTIFIERS

Ordinary rectifier tubes are evacuated just like other receiving and transmitting tubes. Hence, they are called "vacuum rectifiers."

You have already seen curves in Figs. 18 and 19 showing the input voltage available from choke and condenser input filters. These curves were taken with a particular type of rectifier tube; they may be quite different for another type, because of the resistance between the plate and cathode of the rectifier tube. This resistance is between the transformer source and the load. When the tube is supplying current, a voltage drop exists in it. Variations in the load current requirement cause a varying tube voltage drop—and hence a variation in the output voltage, since the tube drop

is subtracted from the source voltage.

If the cathode and plate are spaced close together, the tube resistance will be low, and the voltage drop across the plate-cathode of the tube will be low even with high load currents. Naturally, even a fairly large current variation can't cause much total change in the voltage across a low resistance, so this tube construction gives improved regulation. But the a.c. voltage which can be applied to the plate of such a tube is limited, since too much voltage will cause a flash-over between the plate and cathode and ruin the tube. Let's look into this matter of flash-over a little further.

Peak Inverse Voltage. A rectifier tube should pass electrons from the cathode to the plate when the plate is positive. But what happens when the cathode is positive with respect to the plate, a condition which exists once every cycle of the a.c. supply?

If the voltage is too high, a current will arc (spark) between the elements or between the leads coming through the glass "pinch" (or seal) of the tube. This either breaks the seal, letting air into the tube, or destroys the emission qualities of the cathode. The tube is ruined in either case.

The maximum a.c. voltage that you can connect to a rectifier tube without causing an arc when the plate is negative and the cathode is positive is called the *peak inverse voltage* rating of the tube.

Fig. 27 shows a single diode connected through a load R to a high-voltage secondary. Once each half cycle the tube plate is positive (+), while the cathode (K) is negative (-), and once each half cycle the plate is negative (-) and the cathode is positive (+). When the diode passes electrons, the voltage across the tube is lower than $V_{a.c.}$ because of the

voltage drop in the load R . But when the inverse condition exists (that is, when the plate is negative), no current flows through the tube. Then the voltage $V_{a.c.}$ stored in the condenser C , added to the peak $V_{a.c.}$ across the high-voltage secondary, is applied between the cathode and plate. If the load current is low, the voltage across C may nearly equal the peak of $V_{a.c.}$ (The peak value is 1.41 times the value measured by an a.c. voltmeter.) Therefore, the maximum inverse voltage which is applied between the plate and cathode is $V_{a.c.} \times 1.41 \times 2$ —twice the peak voltage of the transformer secondary. This value must not exceed the peak inverse voltage rating of the tube.

In the case of a full-wave rectifier, the peak inverse voltage will be applied first between one plate and its cathode, and then between the other plate and its cathode. Therefore,

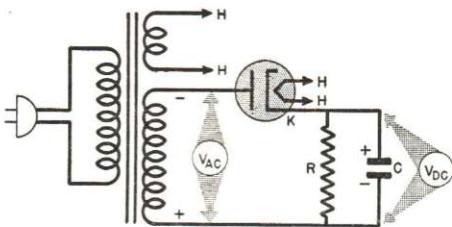

FIG. 27. The peak inverse voltage is the sum of the d.c. output and the peak a.c. input.

both diodes of the full-wave rectifier tube must have the same peak inverse voltage rating.

With a choke input filter in place of the condenser, the voltage $V_{d.c.}$ is considerably reduced. This means that when an input choke is used, a larger a.c. voltage may be applied to the rectifier plates without danger of exceeding the manufacturer's inverse peak voltage rating.

Thus, in choosing a rectifier tube, we must consider not only its d.c.

output current and voltage, but also its peak inverse voltage rating and the peak current which it can safely pass.

MERCURY VAPOR RECTIFIERS

Where we need both high voltage and good regulation, we cannot use a vacuum type tube because the close spacing necessary for good regulation limits the peak inverse voltage rating. Instead, the mercury vapor tube is used. This tube is like a vacuum type with wide plate-to-filament spacing, but contains a small ball of mercury. When the tube heats up, a quantity of mercury vapor is formed and at the same time, an electron cloud forms around the filament.

As electrons speed toward the plate, they strike mercury atoms in the vapor and knock out free electrons, leaving positive gas ions. The extra electrons move toward the plate along with the original electrons. The positive ions move toward the filament getting into the electron cloud, where they combine with electrons and partially destroy space charge effects. This lets more electrons reach the plate from the filament, because fewer are repelled by the cloud back to the filament.

When the load requires more current, more electrons pass through the tube. This increases the collisions with mercury atoms, thus producing more free electrons and further reducing the space charge. Effectively, this is the same as reducing the plate-to-cathode resistance. The increased current through the smaller tube resistance gives about the same tube voltage drop as before, so the output voltage remains almost constant. In fact, the tube drop stays at about 15 volts for all values of current which the tube can safely handle. This constant voltage drop means the d.c. output does

not vary with load current changes, so regulation is excellent.

The heavy ions must not strike the filament as they can destroy its emission. Hence, the peak current must be kept within the tube rating and the electron cloud must form before the tube passes current. Since the mercury vapor tubes used in receivers have quick-heating filaments, this is no problem. When large mercury vapor rectifier tubes are used in transmitters and high power public address systems, a special time-delay relay is

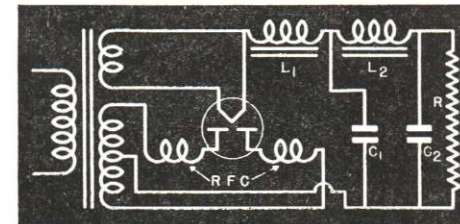

FIG. 28. The mercury vapor tube requires r.f. chokes in the plate leads to keep down interference.

used to turn on the plate power after the filament power is applied and the tube has warmed up.

A typical full-wave mercury vapor rectifier circuit is shown in Fig. 28. In operation, the rectifier tube emits a blue glow which quickly distinguishes it from the vacuum type rectifier tube (which emits no glow when in good condition*). The filter circuit has a choke input, for a condenser

* When a vacuum tube rectifier has been overloaded by excess current, usually caused by a shorted filter condenser, gas is often formed in the envelope. Then there will be a blue glow which at first can be seen inside the space between the plate and cathode. Later, this glow will increase as more gas molecules are released from the metallic structure of the tube. The glow may spread over the entire interior of the tube. Frequently, the excess current causes the rectifier plates to become red hot. The glow in a vacuum type tube is steady and is not usually as brilliant as the flickering glow of a mercury vapor rectifier.

input would cause sharp peak current rushes which would ruin the tube. To improve regulation, the input choke is usually a swinging choke.

Sudden current changes in the rectifier circuit may set up radio frequency (high-frequency a.c.) currents which will interfere with the signals in the signal circuits. For this reason, small r.f. chokes *RFC* are used in each plate circuit. The tube may have to be shielded to prevent stray fields from getting into the signal circuits. Shielding should not be used unless necessary, as it prevents the heat generated by the tube from escaping and so eventually causes tube destruction. A fuse in the power line is recommended; then, if a short circuit or sudden overload causes excessive tube current, the fuse will burn out before the tube cathode is damaged.

BRIDGE RECTIFIER CIRCUIT

The bridge rectifier circuit is a circuit which uses four diodes to get the effect of full-wave rectification from a half-wave transformer. Since the saving in the cost of the transformer is more than the tube cost only in high-power equipment, bridge rectifier circuits are usually found only in transmitting and measuring circuits. Full-wave rectifiers are much more common in radio sets.

A typical bridge circuit is shown in Fig. 29. You will find it easy to remember this circuit by following the electron flow. For example, when terminal *x* is negative with respect to terminal *y* of transformer secondary *S*₁, electrons flow from the supply terminal *x* of *S*₁ to the rectifier terminal *a*, and seek a path through the bridge circuit to terminal *y*. Since the only electron path through a normal tube is from the cathode to the plate, the

electrons cannot go through tube *VT*₄; instead, they pass through tube *VT*₁ to point *b*. The only electron path from point *b* is through the load resistor *R* to point *c*, because the path through tube *VT*₂ is blocked. From point *c*, the electrons travel through tube *VT*₃ to point *d* and then to the supply terminal *y*. This electron path is shown by the solid black arrows.

When the cycle reverses, electrons leave the supply terminal *y* and take the *y*→*d*→*b*→*c*→*a*→*x* path, indicated by the white arrows.

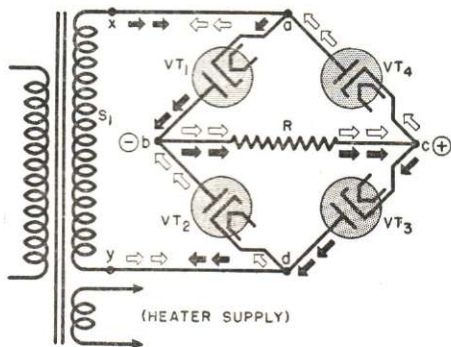

FIG. 29. A bridge rectifier circuit.

As you see, electrons flow from point *b* to point *c* no matter which terminal of the supply they leave. Thus this circuit gives us full-wave rectification between points *b* and *c* without a center tap on the transformer and with a transformer source voltage equal to that fed only one plate of the usual full-wave circuit. Points *b* and *c* form the output terminals of the rectifier; since electrons flow from *b* to *c*, *b* is the negative (-) and *c* is the positive (+) terminal.

Of course, a standard filter circuit is connected between the rectifier output terminals and the load. A voltage divider can be used too, if one is needed.

Lesson Questions

Be sure to number your Answer Sheet 12FR-2.

Place your Student Number on every Answer Sheet.

Send in your set of answers for this lesson immediately after you finish them, as instructed in the Study Schedule. This will give you the greatest possible benefit from our speedy personal grading service.

1. Into what two parts may the circuits of a radio receiver be automatically divided? *THE SIGNAL CIRCUIT*
THE POWER SUPPLY CIRCUIT
2. Briefly give the three important requirements of a power supply.
3. What would you expect to happen to a 2.5 volt filament tube, if it were placed in a 6.3 volt tube socket? *BURN OUT*
4. What type of current exists at the output of the rectifier tube: (1) *a.c.*; (2) pure d.c. or (3) *pulsating d.c.*?
5. What two parts are most widely used in an a.c. filter?
INDUCTIVE REACTANCE
6. What happens to the d.c. voltage when an input filter condenser opens up (loses its capacity)?
AVOID SHORTS
7. As far as the filtering action is concerned does it matter whether the filter choke is placed in the positive or the negative side of the circuit?
DIFFERENCE (ONLY) ON THE NEGATIVE SIDE
INCREASE LIKELY
8. Why is extra current drawn through a voltage divider by a bleeder resistor? *THE BLEEDER MUST DRAW A CURRENT MANY TIMES HIGHER THAN THE POSSIBLE VARIATIONS DRAWN BY THE LOAD.*
9. Suppose the bleeder resistor opens in the circuit shown in Fig. 23. Would you expect the screen grid voltage to: (a) increase; (b) *decrease*, or (c) *remain the same*?
10. Would you expect to find: (1) a choke input; or (2) *a condenser input* filter used with a mercury vapor rectifier tube?



CASHING IN ON DISCONTENT

Discontent is a good thing—if it makes you want to do something worth while. If you had not been discontented, you would never have enrolled for the N.R.I. Course.

Practically every one is discontented. But some of us are “flooded” by discontent. We develop into complainers. We find fault with anything and everything. We end up as sour and dismal failures.

Those of us who are wise use our discontent as fuel for endeavor. We keep striving toward a goal we have set for ourselves. We are happy in our work. We face defeat, and we come out the victors.

At this minute you may be discontented with many things—your progress with your Course, your earning ability, yourself.

Make that discontent pay you dividends. Don't let it throw you down. If you do, you may never be able to get up again. Keep striving to remove the cause of your discontent. Remember that it's always darkest before the dawn. And a real N.R.I. man works hardest and accomplishes most when he is face to face with the greatest discouragements.

J. E. Smith