



RPL-3A

Moseley



INSTRUCTION MANUAL

MODEL RPL-3  
REMOTE PICKUP LINK  
(148-174 MHz)

MOSELEY ASSOCIATES, INC.  
Santa Barbara Research Park  
111 Castilian Drive  
Goleta, California 93017

Revised  
March 1980

(805) 968-9621

# Warranty

All equipment designed and manufactured by Moseley Associates, Inc. is warranted against defects in workmanship and material that develop under normal use within a period of one (1) year, or (2) years for all MRC series equipment, from the date of original shipment, and is also warranted to meet any specifications represented in writing by Moseley Associates, Inc., so long as the purchaser is not in default under his contract of purchase and subject to the following additional conditions and limitations:

1. The sole responsibility of Moseley Associates, Inc. for any equipment not conforming to this Warranty shall be, at its option:
  - A. to repair or replace such equipment or otherwise cause it to meet the represented specifications either at the purchaser's installation or upon the return thereof f.o.b. Goleta, California, as directed by Moseley Associates, Inc.; or
  - B. to accept the return thereof f.o.b. Goleta, California, credit the purchaser's account for the unpaid portion, if any, of the purchase price, and refund to the purchaser, without interest, any portion of the purchase price theretofore paid; or
  - C. to demonstrate that the equipment has no defect in workmanship or material and that it meets the represented specification, in which event all expenses reasonably incurred by Moseley Associates, Inc., in so demonstrating, including but not limited to costs of travel to and from the purchaser's installation, and subsistence, shall be paid by purchaser to Moseley Associates, Inc.
2. In case of any equipment thought to be defective, the purchaser shall promptly notify Moseley Associates, Inc., in writing, giving full particulars as to the defects. Upon receipt of such notice, Moseley Associates, Inc. will give instructions respecting the shipment of the equipment, or such other manner as it elects to service this Warranty as above provided.
3. This Warranty extends only to the original purchaser and is not assignable or transferable, does not extend to any shipment which has been subjected to abuse, misuse, physical damage, alteration, operation under improper conditions or improper installation, use or maintenance, and does not extend to equipment or parts not manufactured by Moseley Associates, Inc. and such equipment and parts are subject to only adjustments as are available from the manufacturer thereof.
4. No other warranties, express or implied, shall be applicable to any equipment sold by Moseley Associates, Inc. and no representative or other person is authorized by Moseley Associates, Inc. to assume for it any liability or obligation with respect to the condition or performance of any equipment sold by it, except as provided in this Warranty. This Warranty provides for the sole right and remedy of the purchaser and Moseley Associates, Inc. shall in no event have any liability for consequential damages or for loss, damage or expense directly or indirectly arising from the use of equipment purchased from Moseley Associates, Inc.

CUSTOMER SERVICE  
INFORMATION

Moseley Associates, Inc. has a Technical Services Department to assist product users who experience difficulties. Our service is available at two levels: telephone consultation and factory service. Different circumstances apply whether the product(s) are under Warranty/Service Agreement status or outside Warranty/Service Agreement status.

Please read the manual; a large portion of telephone calls to Moseley request information which is needed due to non-familiarity with the equipment. The majority of those questions are already answered by the Installation/Operation sections of each manual. If these do not help your problem, the first step in any factory service transaction should always be telephone consultation.

PRODUCTS COVERED BY WARRANTY/SERVICE AGREEMENT

Telephone Consultation

If telephone consultation/assistance is necessary, please have the following information available prior to calling the factory:

- A. Model Number and Serial Number of unit,
- B. Shipment date or date of purchase of Extended Service Agreement,
- C. Module identification markings,
- D. Be prepared to accurately describe the problems with your unit: Constant or intermittent? Precise symptoms? Meter readings? Operational frequency of unit?

Once you are prepared with this information, contact our Technical Services Department for assistance. A Technical Services Representative who knows your product(s) is available during normal work hours (8:00 a.m. to 5:00 p.m., Pacific Time, Monday to Friday). Please do not get upset if the particular Representative you should talk to is busy. Leave your name, call letters, equipment type and telephone number(s) where you can be reached in the next few hours. Someone will get back to you as soon as possible.

Please understand that telephone calls should be kept as short as possible - ultimately our costs in tying up a Technical Service Representative for unnecessary periods of time must result in higher charges on our Service Agreements. It is better to listen to explanations/suggestions/procedures and to call back if you are continuing to experience problems.

If telephone assistance is required, our telephone number is:

(805)968-9621

### Emergency (Only) Telephone Consultation

The above number applies to both normal working hours and to emergency out-of-hours consultation.

Emergency service is provided from 5:00 p.m. to 10:00 p.m., Pacific Time, Monday to Friday, and from 8:00 a.m. to 10:00 p.m., Pacific Time, on weekends and holidays.

This service is for emergencies only. Please do not expect our Representative to know the status of your order, to take spare parts orders and the like.

Arrangements for factory service can be made after consultation with the factory Technical Service Representative and his assignment to you of a Return Authorization (R.A.) Number. This number expedites your equipment's routing from the Receiving Department to Technical Services.

### PRODUCTS OUT OF WARRANTY/NOT COVERED BY A SERVICE AGREEMENT

#### Telephone Consultation

If telephone consultation/assistance is necessary, please have the following information available prior to calling the factory:

- A. Model Number and Serial Number of unit,
- B. Module identification markings,
- C. Be prepared to accurately describe the problems with your unit: Constant or intermittent? Precise symptoms? Meter readings? Operational frequency of unit?
- D. The number of your account and name that account is under (parent organization or whatever) OR major credit card details.

The latter is, unfortunately, necessary because the costs of consultation on an older unit - for which a customer has not purchased an Extended Service Agreement - are enormous; we are happy to provide about fifteen minutes of totally free telephone consultation - and the majority of problems can be solved in that time. Beyond that, we are forced to charge - and we do that at our current hourly rate - in quarter-hour units of time.

Once you are prepared with this information, contact our Technical Services Department for assistance. A Technical Services Representative who knows your product(s) is available during normal work hours (8:00 a.m. to 5:00 p.m., Pacific Time, Monday to Friday). Please do not get upset if the particular Representative you should talk to is busy. Leave your name, call letters, equipment type and telephone number(s)

where you can be reached in the next few hours. Someone will get back to you as soon as possible.

Please understand that telephone calls should be kept as short as possible - ultimately our costs in tying up a Technical Service Representative for unnecessary periods of time must result in higher charges on our equipment. It is better to listen to explanations/suggestions/procedures and to call back if you are continuing to experience problems.

If telephone assistance is required, our telephone number is:

(805)968-9621

Arrangements for factory service can be made after consultation with the factory Technical Service Representative and his assignment to you of a Return Authorization (R.A.) Number. This number expedites your equipment's routing from the Receiving Department to Technical Services.

#### GENERAL

##### Replacement Modules

Moseley Associates encourages the purchase of recommended spare parts kits to allow the customer to be totally self-sufficient with regard to parts. We recognize that there are extenuating circumstances when troubleshooting to the component level is neither practical nor possible. If this is the case, replacement module exchange may be the most expedient way of correcting the problem. Each product manual lists recommended spares.

Non-frequency sensitive replacement modules are normally available for immediate shipment. If you require a replacement module from Moseley Associates, please give your shipping address to our Technical Services Engineer. If the module or equipment to be supplied to your company is to be held at the airport with a telephone number to call, please provide at least two telephone numbers. This will often expedite the delivery or pickup of the replacement module or equipment.

##### Field Repair

Always try to isolate the problem to a specific area or module, if possible. By comparing the actual wave shapes and levels with those referenced on the block and level diagrams or schematics, the problem often can be localized to the component level.

If an integrated circuit is suspect, carefully remove the original and plug in the new one in the same direction. These devices are installed

one way only. Plugging in a new device backward may damage the newly-installed component or the surrounding circuitry. ICs occasionally exhibit temperature-sensitive characteristics. If a suspicious device operates intermittently or appears to drift, Freeze Mist may aid in diagnosing the problem.

If a soldered component has to be removed from a printed circuit board, do the following:

Use a 40 W soldering iron with a 1/8 inch tip. Do not use a soldering gun. Excessive heat may cause damage!

Remove all solder contacting the lead or leads from the component and from the associated printed circuit pad. To assist in the removal of the solder, solder-sipping braid, such as solder wick, is very useful. Once the solder has been removed, remove the component from the board.

When installing the new component, pre-bend the leads of the replacement component so they will easily fit into the appropriate PC board holes. Solder each lead of the component to the bottom side of the board with a 40 W soldering iron with a 1/8 inch tip. Always use a good brand of rosin-core solder. The solder joint should be smooth and shiny. Also, be sure that excessive heat is not used in this soldering operation. Excessive heat will damage the printed circuit pad that comes in contact with the new component. Finally, cut each lead of the replacement component close to the solder on the pad side of the printed circuit board with a pair of diagonal cutters. Then remove all residual flux with either flux cleaner or a cotton swab moistened with flux cleaner.

### Factory Service

When returning your equipment to Moseley Associates, Inc., the following suggestions are offered to assist you. If you are returning a module, ensure that the module is packed sufficiently to withstand the rigors of the journey. Make sure the shipping carton is packed evenly and fully, with packing material filling all voids so that the module cannot shift inside the shipping carton. The package should also be marked in red with the words "Electronic Equipment" or "Fragile." Remember, the condition of the module is totally dependent on the care taken in the packing. Reference the Return Authorization Number that you had previously obtained from the factory on the outside of the carton or on the shipping label. Make sure that the name of your company is listed on the shipping label, and insure your module appropriately.

If you are shipping a complete chassis, all modules should be tied down as they were originally received. On some Moseley Associates equipment, shipping screws are required on the underside or topside of the chassis. In this case, printing on the chassis will indicate where such screws should be installed and secured.

Include any and all descriptions of the difficulties encountered with your equipment in the field. This will greatly assist us in processing your equipment and returning it as expeditiously as possible.

Use the original shipping carton in which your equipment was supplied, if possible. Ensure that the carton is packed evenly and fully with packing material filling any voids so that the chassis cannot shift inside the carton. Make sure the carton is sealed properly with either nylon-reinforced tape or shipping sealing tape. Mark the outside of the carton "Electronic Equipment - Fragile" in big, red letters. This will assist the survival of the equipment in the shipping process. Again, bear in mind that the survival of the unit depends almost solely on the preparation taken in shipping it.

When returning your equipment to our factory, please address it to the following:

MOSELEY ASSOCIATES, INC.  
Attn: Technical Services Dept.  
111 Castilian Drive  
Goleta, California 93117

Display your Return Authorization Number clearly on the shipping label and insure the equipment for the appropriate amount.

All equipment must be shipped prepaid; Moseley Associates, Inc. will return the equipment prepaid under warranty and Service Agreement conditions, and either freight collect or billed for equipment not covered by warranty or a Service Agreement.



## TABLE OF CONTENTS

	Page
I. INTRODUCTION	1
II. SPECIFICATIONS	2
A. Overall System	2
B. Transmitter	2
C. Receiver	3
III. UNPACKING	4
IV. INITIAL CHECK-OUT PROCEDURE	4
V. INSTALLATION	5
A. Transmitter	5
B. Receiver	6
C. Antenna and Transmission Line	6
VI. OPERATION	7
A. Transmitter	7
B. Receiver	8
VII. CIRCUIT DESCRIPTION	8
A. Transmitter	8
B. Receiver	11
VIII. FIELD ADJUSTMENTS	12
A. Transmitter	12
B. Receiver	12
IX. SERVICING	12
X. OPTIONAL MODEL AMP-3 RF POWER AMPLIFIER	12

## INSTRUCTION MANUAL

### MODEL RPL-3A

### REMOTE PICKUP LINK

#### I. INTRODUCTION

The Model RPL-3 Remote Pickup was designed to provide a high-quality program link between the broadcast studio and an outside or remote broadcast location. Operating in the 148-174 MHz band, the RPL-3 system is designed for two channel operation with the second set of crystals optionally available.

The RPL-3 consists of a Transmitter and a Receiver. The Transmitter was designed to operate continuously from 120/240 VAC, 50-60 Hz, and from 13.5 VDC negative ground, and comes supplied with an AC power cord and a DC cable connector.

The Transmitter has been compactly and ruggedly designed to facilitate its use in mobile or fixed portable service. All input and output connectors are conveniently located near the front panel of the Transmitter for operator convenience. Easy access is afforded to all circuitry due to the modular design of the system.

Metering of important parameters is provided on the RPL-3 Transmitter. For monitoring audio levels, a PEAK AUDIO position is provided. Metering is also provided for relative FORWARD POWER, relative REFLECTED POWER, relative I.P.A. DRIVE, actual FINAL CURRENT, and POWER SUPPLY VOLTAGE.

For applications requiring higher RF output, the Moseley Associates Model AMP-3 may be used in conjunction with the RPL-3 Transmitter. The Model AMP-3 provides a 6 dB power gain. With a 10 watt input, the AMP-3 will yield 40 watts of RF output. This amplifier is not recommended in aeronautical service. This has followed a policy of limiting airborne transmitter power output to 18 watts.

The Receiver requires only 1-3/4 inches of vertical rack space. To assist the operator in optimizing antenna orientation for remote pickup broadcasts, a front-panel signal-strength meter continuously monitors the received signal. Selectors are provided to select the desired frequency channel either from the front panel or from a remote location.

## II. SPECIFICATIONS

### A. Overall System

Audio Response	±1.5 dB, 30-7500 Hz
Distortion	Less than 1.3%, 30-10,000 Hz
Signal-to-Noise Ratio	55 dB below 100% modulation (60 dB typical)
Frequency Range	148-174 MHz. Two frequency operation within 1 MHz spacing. One set of crystals supplied with link.

### B. Transmitter

RF Output	15 watts maximum, 10 watts minimum into 50Ω load. Output connector Type BNC female.
VSWR Protection	Withstands infinite VSWR at all phase angles.
Deviation	(±5 kHz for 100% modulation)
Frequency Stability	0.00025% (-30°C to 50°C)
Operating Temperature Range	-20°C to 60°C
Audio Inputs	3 independent channels (two microphone and one line)
Audio Input Impedances Line Microphone	50,000Ω bridging, unbalanced 50-150Ω, balanced, floating
Audio Input Levels Line Microphone	-10 dBm to +10 dBm from 600Ω source -60 dBm to -40 dBm
Audio Peak Limiter	Control range greater than 25 dB, attack time 1 ms, release time 700 ms.

Metering	Peak Audio, Forward RF Power, Reflected Power, Final Amp. Current, I.P.A. RF Drive, and Power Supply Voltage.
Audio Monitoring	Utility output with adjustable gain for feeding headphones or other audio amplifiers.
Power Requirements	
AC	120/240 VAC, $\pm 15\%$ , 50-60 Hz, 45 watts maximum
DC	13.5 VDC, negative ground, 2.5A maximum, 15 VDC maximum, 12 VDC minimum.
Size	4 inches high, 14-1/2 inches wide 11 inches deep (102 mm x 368 mm x 279 mm)
Weight	16 pounds net (7.2 kg. net)

### C. Receiver

Sensitivity	3.0 microvolts for 20 dB quieting 30 microvolts for 40 dB quieting
Selectivity	-6 dB at $\pm 22$ kHz -60 dB at $\pm 42$ kHz
All Spurious Responses	65 dB below -40 dBm reference
Frequency Stability	$\pm 0.0005\%$ (-20°C to 60°C)
RF Input	50 $\Omega$ , unbalanced, input connector Type UHF female
Audio Output	+10 dBm @ 100% modulation, 600 $\Omega$ balanced
Squelch	Automatic and adjustable, electronic. Carrier-operated relay output (Form C contacts) optionally available.
Operating Temperature Range	-30°C to 60°C

Power Requirements	120/240 VAC, $\pm 15\%$ , 50-60 Hz, 10 watts
Size	1-3/4 inches high, 19 inches wide, 10 inches deep (44.5 mm x 484 mm x 250 mm)
Weight	13 pounds net (5.9 kg. net)

### III. UNPACKING

The RPL-3 Transmitter and Receiver should be unpacked and carefully inspected for concealed damage due to shipping. Retain all boxes and packing material in the event a claim is to be filed against the carrier for damages.

#### NOTE

Do not attempt any tuning at this time. Field Adjustment Procedures are outlined on pages 13 and 14 of this manual.

### IV. INITIAL CHECK-OUT PROCEDURE

In order to check out the equipment, it will be necessary to connect a  $50\Omega$  RF termination with a dissipation rating in excess of 15 watts to the BNC connector on the rear of the Transmitter. Check to see that the Transmit Function selector is in the STANDBY position, and that the POWER AUDIO switch is not depressed. Connect the line cord to a source of 120 VAC, 50-60 Hz. Note: For 240 VAC, 50-60 Hz operation, refer to drawing 91C6583 for information on rewiring the primary of transformer T101.

Once the Transmitter has been properly terminated, depress the push button marked POWER AUDIO. This applies power to the audio section, multiplier/driver, and the RF power amplifier. Note, however, there will not be any RF output at this time. Place the Metering Selector in the FORWARD POWER position and select the proper Transmit Function. Either FREQ. 1 or FREQ. 2 may be selected if the optional set of crystals for dual frequency operation has been installed. If the system is set up for single frequency operation, FREQ. 1 will be used.

Once the proper Transmit Function has been depressed, there should be an indication on the front-panel meter which is a reading of relative forward power. It would be advisable to check the actual power output with a wattmeter to become familiar with the relative meter

readings in relation to their actual values. The wattmeter should read between 10 and 15 watts. The metering functions of REFLECTED POWER and I.P.A. DRIVE are also relative values while PEAK AUDIO, FINAL CURRENT, and POWER SUPPLY (Vcc) are actual readings; FINAL CURRENT (0-2.5 amps) and Vcc (0-25 VDC). PEAK AUDIO in dB is read on the upper scale.

Actual values may be compared with the final test values which are located at the end of the text of this manual. Variations of 20% may be expected.

Once it has been established that the Transmitter is operating properly, place the Receiver nearby and connect it to the 120 VAC, 50-60 Hz source. Note that the RPL-3 Receiver does not have a power switch. The L.E.D. indicator located on the front panel will illuminate when the Receiver is connected to the power source. For 240 VAC, 50-60 Hz operation, see drawing 91C6597. A small piece of wire should be inserted into the UHF connector located on the rear of the chassis to minimize multipath effects. The 600 $\Omega$  balanced output of the Receiver should be connected to a monitor amplifier or suitable test equipment. If specific audio measurements are to be made, the Receiver output should be terminated with a 560 $\Omega$  resistor.

To verify the operation of the RPL-3 System, apply a +10 dBm signal at 1000 Hz to the Line Input of the Transmitter. Adjust the Line Input Control until the meter on the Transmitter reads 0 dB with the Metering Selector in the PEAK AUDIO position. If the Receiver is terminated properly, a +10 dBm signal should be present at the output.

The microphone inputs may be tested at this time. These inputs have an impedance of 50-150 $\Omega$ .

## V. INSTALLATION

### A. Transmitter

The Transmitter may be operated from AC and DC power sources. As received from the factory, the RPL-3 is wired for both 120 VAC, 50-60 Hz, and 13.5 VDC operation. Never connect both AC and DC inputs at the same time. If it is desired to operate the Transmitter from 240 VAC, 50-60 Hz, it will be necessary to rewire the primary of transformer T101 as shown in drawing 91C6583. If the RPL-3 Transmitter is to be operated from 13.5 VDC, connect the DC source using the cable connector provided. The cable connector is keyed so that

it can be connected only one way; however care should be taken when connecting the DC power cable to the cable connector to insure proper polarity. See drawing 91C6583 for proper connection. Diode protection has been provided within the regulator, and in the event the polarity is accidentally reversed, the Transmitter will simply not operate.

#### CAUTION

Do not connect the RPL-3 Transmitter to a DC source greater than 15 VDC as damage to the unit may result.

When the Transmitter is to be used in a fixed location, care should be taken to provide adequate ventilation. If the Transmitter is used for mobile operation, it may be desirable to fabricate a mounting bracket. Due to the wide variety of applications and vehicles, no mounting bracket is supplied or available. The same considerations regarding air circulation still apply in mobile operation.

#### B. Receiver

The Receiver operates from 120/240 VAC, 50-60 Hz. If it is desired to operate from 240 VAC, it will be necessary to rewire the primary of the power transformer, see drawing 91C6597 for details.

If remote selection of the frequency channel is desired, use the appropriate barrier terminals on the rear of the chassis. A SPDT contact configuration is required for this function. The program output of the Receiver is available from the same barrier strip.

#### C. Antenna and Transmission Line

Transmission line considerations will determine to some extent the placement of the Transmitter and Receiver. Lengthy transmission lines will introduce unwanted amounts of attenuation. Therefore, it is always good practice to place both the Transmitter and Receiver as close to the antenna as possible. If a long length of transmission line is required, use the lowest loss line practical.

There are many possible antenna configurations which will work satisfactorily with the RPL-3, and the choice should be determined by

the application and service of the equipment. The internal metering of the RPL-3 may be used to help match the antenna to the Transmitter. Observe the reflected power by placing the Metering Selector in the REFLECTED POWER position. Tune the antenna for minimum indication on the meter, consistent with maximum forward power. It should not be necessary to adjust the transmitter as it has been factory aligned for operation into a 50 $\Omega$  load. When installing the antennas, make sure that both the transmitting and receiving antennas are polarized in the same plane.

## VI. OPERATION

### A. Transmitter

To place the RPL-3 Transmitter into operation, check to see that the POWER AUDIO switch is not depressed and that the Transmit Function is in STANDBY. Connect the AC power cord to a source of 120 VAC, 50-60 Hz, or connect a DC source of 13.5 VDC, negative ground, to the DC power plug located on the rear of the chassis. Never connect both AC and DC inputs at the same time. Due to the wide variety of mobile installations, no DC power cable is provided. However, a connector is provided to allow for the fabrication of a suitable power cable. When fabricating this cable, be certain to observe the correct polarity, and select the proper wire size to avoid excessive voltage drop.

Connect all audio equipment that is to be used in conjunction with the RPL-3 to the Transmitter. The two Microphone Inputs are located on the right side of the chassis, while the Line Input and Utility Output jacks are located on the left side. Connect the RF transmission line to the antenna and to the BNC connector located on the rear of the Chassis.

Power is applied to the audio section, multiplier/driver, and RF power amplifier by depressing the push button labeled POWER AUDIO. However, this does not place the Transmitter in a radiating condition. To place the Transmitter on the air once the POWER AUDIO push button has been depressed, simply select the proper Transmit Function.

Either FREQ 1 or FREQ 2 may be selected if the system has been equipped with the optional set of crystals for dual frequency operation. FREQ 1 will be used if the system is not equipped with the optional crystals.



Relative forward power, as well as other metering functions, may be observed by selecting the appropriate position on the Metering Selector.

With the POWER AUDIO push button depressed and the Transmit Function in STANDBY, the audio mixer section of the Transmitter Unit may be used for other applications, or this condition may be used to preset audio levels before placing the Transmitter in a radiating condition.

## B. Receiver

The operation of the RPL-3 Receiver is very simple since there are only three controls for the operator's use; the receiver frequency selectors labeled FREQ 1 and FREQ 2, and REMOTE SELECT. The frequency selectors are used to determine on which channel the Receiver will operate. The REMOTE SELECT is used when it is desired to select the Receiver frequency channel from a remote location. Barrier terminals have been provided on the rear of the chassis for this function. A SPDT contact configuration is required.

A relative signal strength meter has been incorporated into the Receiver to assist in the setup of the RPL-3 System. Also incorporated in the Receiver is a provision for an optional carrier-operated relay which may be used for external control purposes.

## VII. CIRCUIT DESCRIPTION

### A. Transmitter

The Transmitter is comprised of five major subassemblies: power supply, VCXO, multiplier/driver, RF power amplifier, and audio section.

#### 1. Power Supply

The power supply regulator exhibits an exceptionally low forward voltage drop so that it cannot only regulate the rectified filtered AC input but also the unregulated 12-15 VDC input for extremely stable RPL-3 operation. Q102 biases and temperature compensates Q104, the current clamping transistor. Q103 is a current driver for the series pass transistor Q101. CR101, CR102, CR103 set a bias on the voltage regulator IC101.

## 2. Two-Channel VCXO

In order to generate a stable signal at the output frequency in the 148 to 174 MHz band and at the same time frequency-modulate the carrier, a VCXO (voltage-controlled crystal oscillator) is used. Q1, L1, C10, C11, and Y1 comprise the basic 4 MHz oscillator. Frequency multiplication of 36 times following the oscillator produces the desired output frequency. To produce frequency modulation (refer to drawing 91C7164), two diodes, CR1 and CR2, which change capacity as a function of voltage, are employed in the oscillator circuitry. Temperature compensation is achieved by application of DC bias to the modulator diodes. Thermistors (temperature variable resistors) R10 and R12 and a resistor network, R15, R9, R11, R13, R14, and R18, provide the necessary corrective bias for operation over the specified temperature range.

The channel 1 VCXO, Q1, output drives emitter follower Q2 which isolates the oscillator circuitry from loading. Q5 is used as an OR amplifier and passes the 4 MHz signal from whichever crystal oscillator is operating. Q6 is a current amplifier with an R.F. output of approximately 0 dBm into 50 ohms. In Channel 2 operation, transistors Q3 and Q4 operate in the same manner as Q1 and Q2.

In order to limit the RF bandwidth with high frequency audio, a three section audio low-pass filter (U1 and associated components) limits the audio which can be transmitted to 7.5 kHz.

## 3. Multiplier/Driver

Transistor Q1 is a frequency tripler followed by another tripler, Q2, operating with output frequencies at 12.3 to 14.5 and 36.9 to 43.5 MHz respectively. Tuned circuits (L2, C4, C8), (L3, C10, C11), (L4, C13, C14), (L10, C16), (L5, C5, C17) and (C6, C19, L6) are employed to remove undesired frequency components appearing because of frequency multiplication. CR3, C45, C46, C44, L1, R21, R22 and R23 are part of a phase modulator and are not used in the RPL series of transmitter. Doubler Q3 multiplies the signal to 74-87 MHz with (L7, C23, C31) and (C25, C40, L8) passing only the desired signal to Q4. This transistor is used to double the signal to 148-174 MHz with (L9, C28) and (L17 and C29) used to remove the unwanted signals. Q5, an amplifier with the output at 148-174 MHz, and filter (L13, C32) amplify and filter the signal before it is amplified in the final transistor Q6. The filter (L15, C34), (L11, C38) and (L12, C39) is triple-tuned to the desired output, reducing all unwanted signals to at least 60 dB lower than the 100 MW nominal, 148-174 MHz desired signal. See drawings 91C6980 and 20A2609.

#### 4. RF Power Amplifier

The approximately 100 milliwatts of RF power developed in the Multiplier/Driver subassembly is applied to the Power Amplifier subassembly where Q701 and Q702 amplify the 148-174 MHz signal to a power level of 10 watts nominal into 50 ohms. C701, C703, L701, Z701 and R701 filter and match the 50 ohm input signal to the base of Q701. C707, C708, Z704 and R704 match and filter the RF signal from the output of Q701 to the input of Q702. The output stage Q702 is matched to the antenna output with a complex matching network formed by L704, L705, L706, L707, L708, C712, C713, C715, C716 and C717. This highly selective multi-section filter attenuates all unwanted signal to at least 60 dB below the main signal. A dual-directional coupler samples the relative forward and reflective RF energy and is indicated on the front-panel meter. The overall amplifier efficiency is on the order of 50 percent. See drawings 91B6604 and 20A2374.

#### 5. Audio Section

The audio printed circuit board is located directly behind the front panel. Schematic and component layout can be seen in drawings 91C6584 and 20A2356. The audio section consists of three major subsections; mixer, limiter amplifier, and peak audio limiter.

There are three inputs available; two 50-150 $\Omega$  balanced, floating microphone inputs, and one 50,000 $\Omega$  bridging, unbalanced line input. These inputs are combined electronically by an active mixer, IC2. The output of the active mixer is applied to the limiter amplifier, IC3. IC3 supplies audio to the VCXO for modulation. It also supplies audio to the utility amplifier and the phase inverter which, in turn, feeds the meter driver and peak detector.

The peak audio limiter is composed of a solid-state optical attenuator, limiter amplifier IC3, phase inverter IC5, peak detector IC7, and buffer amplifier IC8. This limiter has an attack time of 1 millisecond and a release time of 700 milliseconds with a typical control range greater than 25 dB.

The utility amplifier output is an unbalanced 600 $\Omega$  with an output of 0 dB, which can be used to drive a monitor amplifier, headphone, tape recorder, or telephone line.

Adjustments are provided for Modulation Level (R35), Utility Level (R27), Meter Calibration (R47), Meter Zero Adjust (R66), and Meter

Acceleration (R51). It is not recommended that the Meter Acceleration be adjusted in the field as it has been pre-adjusted at the factory for optimum response and should require no further adjustment.

Pre-emphasis is standard on the RPL-3. However, if it is desired to operate the system without pre-emphasis, refer to drawings 91C6584 and 20A2356 for information on pre-emphasis components.

## B. Receiver

The RPL-3 Receiver is a superheterodyne, dual-conversion type receiver employing 30 MHz and 10.7 MHz I.F. frequencies. The Receiver is composed of eight subassemblies; first converter, two-channel local oscillator, 30 MHz bandpass filter, 30 MHz-10.7 MHz converter, crystal bandpass filter, FM demodulator, audio processor, and power supply. The schematic for the Receiver can be seen in drawing 91C6597.

The received signal is applied to the first converter along with the local oscillator output. This converts the received signal down to 30 MHz, which is then passed through a 30 MHz bandpass filter to reduce unwanted signals. The output of the filter is then applied to the second converter which converts the 30 MHz signal down to 10.7 MHz. The output of this converter is passed through a 10.7 MHz crystal bandpass filter and applied to the FM demodulator. The FM demodulator is of the ratio type, and included in the demodulator is a high gain RF amplifier limiter IC. The output of the demodulator is then applied to the audio processor where it undergoes amplification and filtering before reaching the 600 $\Omega$  balanced output of the receiver.

The receiver employs a variable electronic squelch. The squelch level is adjusted by R6 on the audio processor board. The output of the Receiver may be adjusted from its nominal +10 dBm output at 100% modulation  $\pm 3$  dBm by R26 on the audio processor board. Also, provisions are included on the audio processor board to allow for the addition of an attenuator pad to provide an output other than the nominal +10 dBm.

De-emphasis is standard on the RPL-3 Receiver. If it is desired to run the system flat, refer to drawing 91C6595 and 20A2367 for information on de-emphasis components.

## VIII. FIELD ADJUSTMENTS

### A. Transmitter

Complete tuning of the Transmitter in the field is not recommended. However, slight frequency adjustments may be accomplished by adjusting L2 for Channel 1 and L7 for Channel 2.

### B. Receiver

In normal operation there will be little or no need to adjust the Receiver in the field. However, C101, C102, C109, and C111 in the first converter may be adjusted to improve Receiver sensitivity. Trimmer capacitors are provided within the two-channel local oscillator to allow for adjustment of the oscillator frequency. Capacitor C203 adjusts the Channel 1 frequency and C212 adjusts the Channel 2 frequency.

## IX. SERVICING

If it should become necessary to troubleshoot the RPL-3 System, complete schematics and component layout diagrams have been provided and are located at the rear of this manual. All test point voltages are shown on the schematics to aid in localizing any problem. Because of its modular design, the RPL-3 should be relatively simple to troubleshoot should it become necessary.

If factory assistance is needed, please note all pertinent voltages, attempts made in trying to locate the trouble, and any other information that may be helpful in diagnosing the problem. Contact Moseley Associates, Inc. at any time regarding any problem encountered with the RPL-3. Direct any inquiries on the operation of the RPL-3 to our Customer Service Department.

## X. OPTIONAL MODEL AMP-3 RF POWER AMPLIFIER

When it is felt that additional output from the RPL-3 Transmitter is desired for extended coverage or other requirements, the Model AMP-3 RF Power Amplifier may be used in conjunction with the RPL-3 Transmitter. This amplifier provides a 6 dB power gain, and, with a 10-watt input, will produce an output of 40 watts. Installation of the AMP-3 is straightforward. Consideration should be given to placement of the amplifier so air can circulate freely by the heat sink. Further, wiring for the DC supply voltage to the AMP-3 should

be of sufficient size to provide up to 7 amperes of current without an appreciable voltage drop. Voltage requirements are 13.5 VDC, negative ground. It is suggested that wire of equivalent size be used for ground return to a common point. In a vehicle, do not rely on the body as a ground return. Control of the AMP-3 is not required as only negligible current is drawn without RF drive. Current is drawn only with the presence of RF input.

ITEM NUMBER: 9050170 \*\*\* SPARE PTS KIT RPL-3 140-174MHZ PAGE 1  
 MOSELEY ASSOCIATES, INC.  
 111 CASTILIAN DRIVE KIT NUMBER: SP-18 A DATE 1/19/84  
 GOLETA, CA. 93117  
 (805) 968-9621

COMPONENT ITEM NO.	MANUFACTURER PART NUMBER	QTY PER	UNIT PRICE	EXTENDED PRICE
3600145	1N4154 DIO 1N4154 25V 4NS SI D035	6	.29	1.72
3610003	10D2 DIO 10D2 200V 1A SI D039	4	.35	1.39
3610045	5082-2835 DIO 5082-2835 FAST	1	1.30	1.30
3610086	MDA-801 DIO MDA-801 100V BRIDGE 8A	1	13.52	13.52
3610151	MV-1624 DIO VMV-1624 020V 9-11PF D07	2	2.98	5.95
3610193	VTL-5C2 DIO VTL-5C2 LDR	1	8.61	8.61
3630001	2N918 XT NS2N918 .4W600M030V50M2P	2	2.09	4.18
3630035	2N3053 XT NP2N3053 05W100M080V.7A	1	1.26	1.26
3630076	2N3563 XT NS2N3563 .2W600M030V50M2P	2	.35	.70
3630159	2N3819 XT NF2N3819 .4W 025V20M	1	1.58	1.58
3630191	2N4037 XT PP2N4037 01W060M060V01A	2	1.44	2.88
3630233	2N4427 XT NP2N4427 02W500M040V.4A	1	3.68	3.68
3630241	2N4428 XT NP2N4428 3.5W750M055V.42A	1	3.93	3.93
3630308	2N5179 XT NS2N5179 .2W900M020V50M1P	2	2.52	5.04
3630365	2N5946 XT NP2N5946 037W 036V02A	1	39.90	39.90
3630399	3N140 XT NF3N140 .4W 020V50M	1	4.69	4.69
3630415	3N204 XT NF3N204 .36W025V	1	2.87	2.87
3640091	C3-12 XT NPC3-12 010W470M017V01A	1	29.23	29.23
3640182	MJ-2955 XT PPMJ2955 115W2.5M060V15A	1	2.45	2.45
3640224	TIP-32A XT PPTIP-32A 02W003M060V03A	1	1.23	1.23
3650116	MC1723CL RGLTR TYPE 1723 VARV .15A 632	1	1.44	1.44
3660008	UA741CP IC UA741P OPAMP GEN COMP	2	.74	1.47
3660024	UA748CP IC UA748P OPAMP UNCOMP	2	1.09	2.17
3730173	LM-318N IC LM318N OPAMP HISPEED	1	2.84	2.84

ITEM NUMBER: 9050170 \*\*\* SPARE PTS KIT RPL-3 140-174MHZ PAGE 2  
 MOSELEY ASSOCIATES, INC. KIT NUMBER: SP-18 A DATE 1/19/84  
 111 CASTILIAN DRIVE  
 GOLETA, CA. 93117  
 (805) 968-9621

COMPONENT ITEM NO.	MANUFACTURER PART NUMBER	QTY PER	UNIT PRICE	EXTENDED PRICE
3730322	MC1350P IC MC1350P OPAMP	1	2.73	2.73
3730348	MC1355P IC MC1355P AMP FM/IF	1	4.18	4.18
3730835	UA739 IC UA739 OPAMP LONOISE	1	5.25	5.25

== TOTAL EXTENDED PRICE: 156.19 ==



ITEM NUMBER: 9050782 #### OPT S/P KIT RPL-3 RPU 140-174  
MOSELEY ASSOCIATES, INC.  
111 CASTILIAN DRIVE  
GOLETA, CA. 93117  
(805) 968-9621

PAGE 1

KIT NUMBER: SP-18 B

DATE 1/20/84

COMPONENT ITEM NO.	MANUFACTURER PART NUMBER		QTY PER	UNIT PRICE	EXTENDED PRICE
3370228	MDL 1/4 FUSE MDL-1/4	AMP (SLOW-BLO)	5	2.38	11.90
3370251	MDL 1 FUSE MDL-1	AMP (SLOW-BLO)	5	1.56	7.80
4090312	3-1086 AO XFMR	3-1086	1	22.17	22.17
4090338	3-1093A A XFMR 8-P-86	3-1093A	1	41.90	41.90
4350211	3143HA802U025 CAP 8000/25V		1	12.15	12.15

## TOTAL EXTENDED PRICE: 95.92 ##

ITEM NUMBER: 9051277 \*\*\*\*\* CPT CRYSTAL RPL-3 140-174 MHZ  
MOSELEY ASSOCIATES, INC.  
111 CASTILIAN DRIVE  
GOLETA, CA. 93117  
(805) 963-9621

PAGE 1  
DATE 1/24/34

KIT NUMBER: SP-13 C

COMPONENT ITEM NO.	MANUFACTURER PART NUMBER	QTY PER	UNIT PRICE	EXTENDED PRICE
3340023	30A0013 D XTAL 40.7 MHZ RPL3/4, 101/505	1	40.00	40.00
3340411	30A0017 D XTAL RX 14L-230 MHZ RPL3, 101	1	40.00	40.00
3340635	30A0059 90 XTAL TX 140-174 MH RPL/101 65C	1	40.00	40.00

\*\* TOTAL EXTENDED PRICE: 120.00 \*\*

21A2373 B0

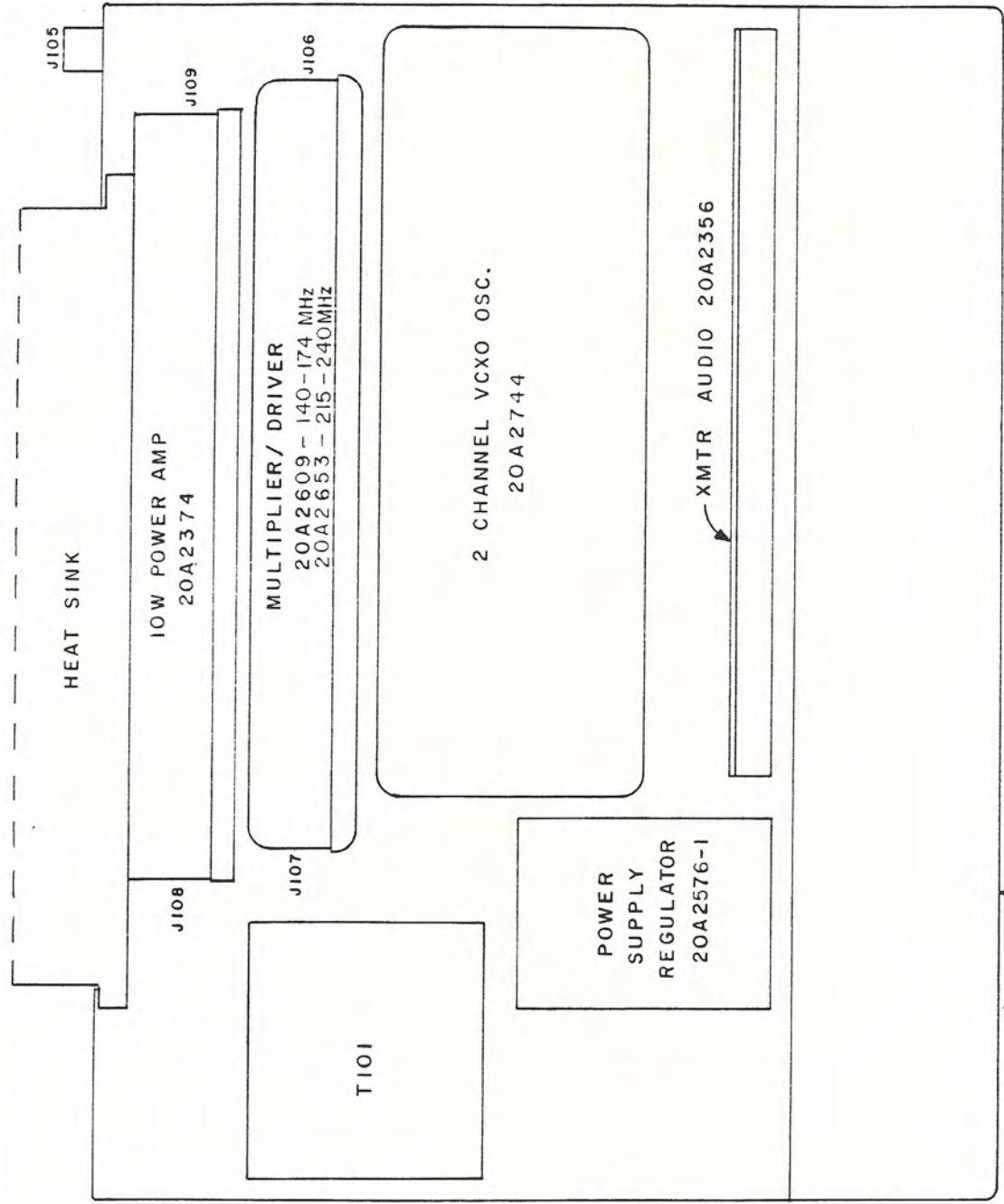

J101  
J102

J103  
J104

**MOSELEY ASSOCIATES, INC.**  
SANTA BARBARA RESEARCH PARK  
GOLETA, CALIFORNIA 93017

**FIGURE 1**  
**RPL-3 TRANSMITTER LAYOUT**

TOL: FRACT. ± 1/32, .XX ± .030, .XXX ± .010, <± 1/20

DWN	F X Y	6/29/73	SCALE: 1/2
CHK			
ENG			

21A2378 B

MGMT. APPR.

REVISIONS	DATE
20A2609-1	12-NOV-79
20A2609-2	12-NOV-79
20A2609-3	12-NOV-79
20A2609-4	12-NOV-79
20A2609-5	12-NOV-79
20A2609-6	12-NOV-79
20A2609-7	12-NOV-79
20A2609-8	12-NOV-79
20A2609-9	12-NOV-79
20A2609-10	12-NOV-79
20A2609-11	12-NOV-79
20A2609-12	12-NOV-79
20A2609-13	12-NOV-79
20A2609-14	12-NOV-79
20A2609-15	12-NOV-79
20A2609-16	12-NOV-79
20A2609-17	12-NOV-79
20A2609-18	12-NOV-79
20A2609-19	12-NOV-79
20A2609-20	12-NOV-79
20A2609-21	12-NOV-79
20A2609-22	12-NOV-79
20A2609-23	12-NOV-79
20A2609-24	12-NOV-79
20A2609-25	12-NOV-79
20A2609-26	12-NOV-79
20A2609-27	12-NOV-79
20A2609-28	12-NOV-79
20A2609-29	12-NOV-79
20A2609-30	12-NOV-79

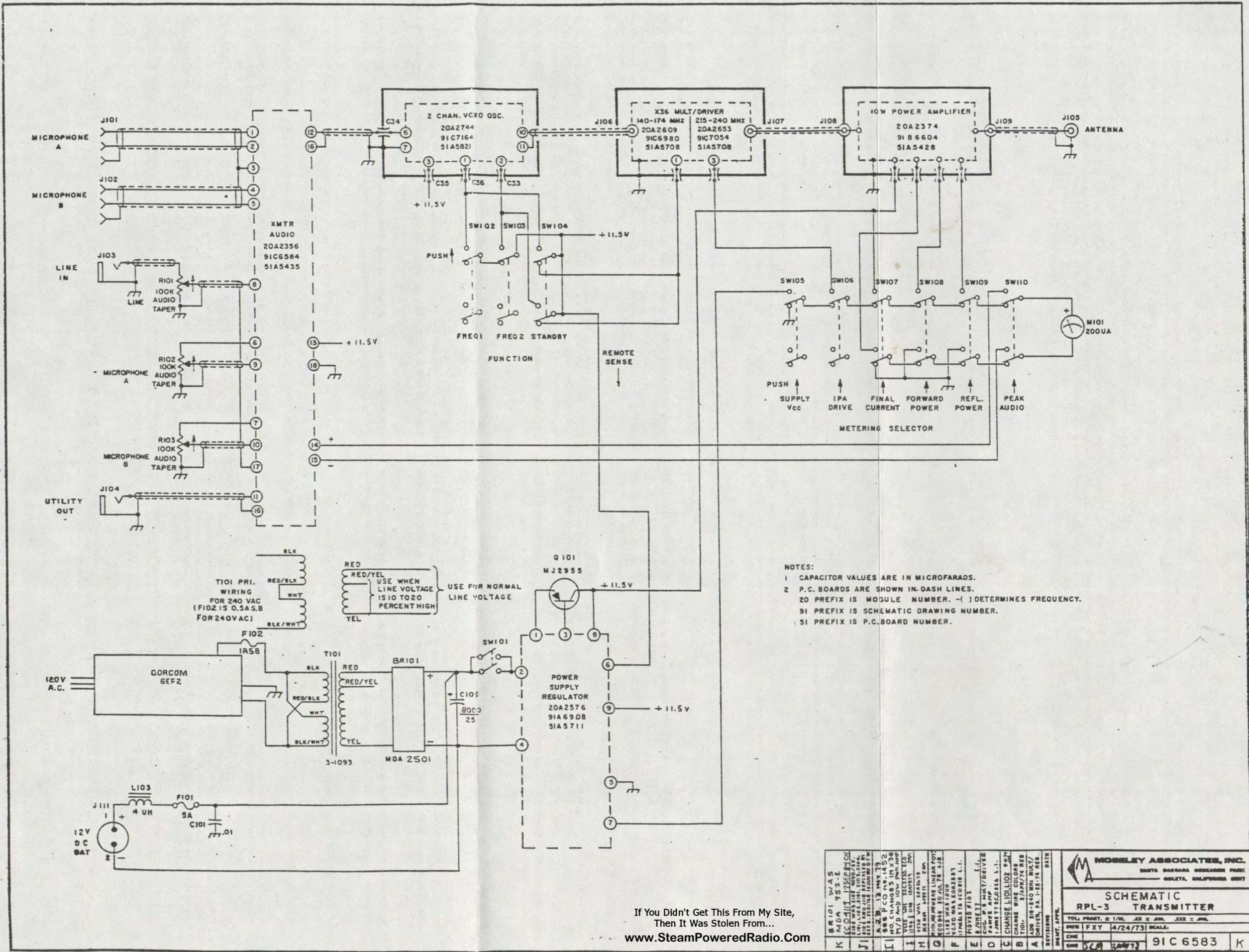

NOTES:  
 1 CAPACITOR VALUES ARE IN MICROFARADS.  
 2 P.C. BOARDS ARE SHOWN IN-DASH LINES.  
 20 PREFIX IS MODULE NUMBER. -( ) DETERMINES FREQUENCY.  
 91 PREFIX IS SCHEMATIC DRAWING NUMBER.  
 51 PREFIX IS P.C. BOARD NUMBER.

RPL-3 TRANSMITTER	
DATE: 4/24/73	
SCALE:	
DRAWN BY: FXY	
CHECKED BY: SCA	
DATE: 4/24/73	
91C 6583	

If You Didn't Get This From My Site,  
 Then It Was Stolen From...  
[www.SteamPoweredRadio.Com](http://www.SteamPoweredRadio.Com)

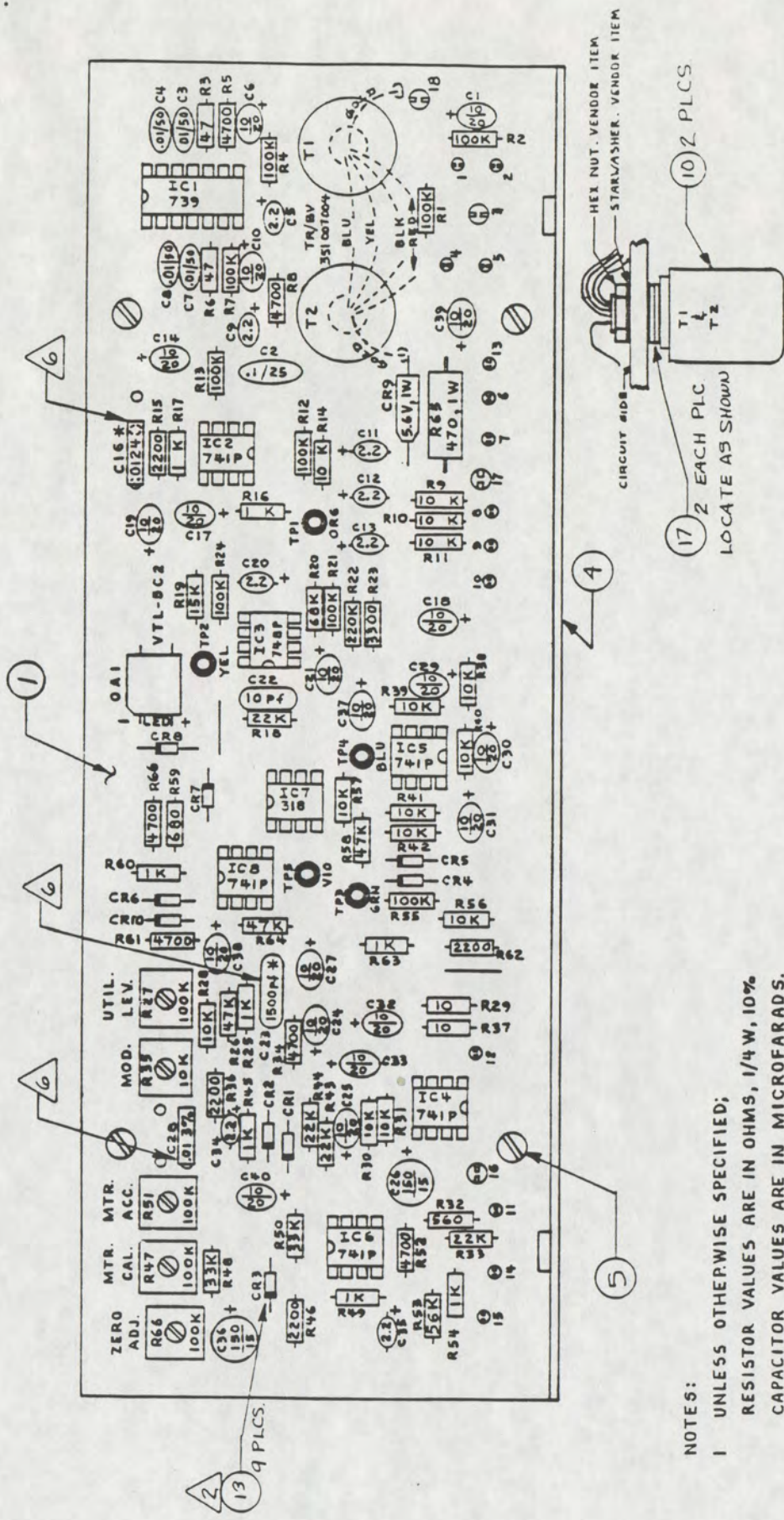

NOTES:

- 1 UNLESS OTHERWISE SPECIFIED; RESISTOR VALUES ARE IN OHMS, 1/4 W, 10% CAPACITOR VALUES ARE IN MICROFARADS.
- 2 DENOTES IN4154 DIODE.
- 3 P.C. BOARD 51A5435
- 4 SCHEMATIC 91C6504.
- 5 \* REMOVE C16 & C23 TO REMOVE DE-EMPHASIS.
- 6 C16, C23, C28 TO BE INSTALLED IN FINAL TEST IF NEEDED.

- 1
- 2
- 3
- 4
- 5
- 6

If You Didn't Get This From My Site,  
Then It Was Stolen From...  
[www.SteamPoweredRadio.Com](http://www.SteamPoweredRadio.Com)

REVISIONS		DATE
A	DAI WAS MOUNTED VERT	21 MARCH 75
B	ADD BOARD WIRES, ADD BOARD TRANSFORMER M.T.D.	
C	IC7 WAS 714 ECO	07 2-2177 JAM
D	ADD PLAT WASHER TO T1 & T2, 20WATERS BWF	
E	ADD TERMINALS & NOTE #	07 FEB 74 ECO 1063 A2B
F	IC3 WAS 54K, ECO 116	
G	CLARIFIED DETAILD DWS	
H	CD 118L 270UNTS JAM	
I	LATEST ARTWORK SHOWN	05023 90CT75 D.T.W
J	FLOOR 9 19MAY81 CAJ	
K	SHOW CORRECT MTS, T1, T2	
L	IC3 WAS 100K, ECO	
M	IC3 WAS 100K, ECO	
N	IC3 WAS 100K, ECO	
O	IC3 WAS 100K, ECO	
P	IC3 WAS 100K, ECO	
Q	IC3 WAS 100K, ECO	
R	IC3 WAS 100K, ECO	
S	IC3 WAS 100K, ECO	
T	IC3 WAS 100K, ECO	
U	IC3 WAS 100K, ECO	
V	IC3 WAS 100K, ECO	
W	IC3 WAS 100K, ECO	
X	IC3 WAS 100K, ECO	
Y	IC3 WAS 100K, ECO	
Z	IC3 WAS 100K, ECO	

MGMT. APPR. \_\_\_\_\_  
 DATE \_\_\_\_\_  
 TOL: FRACT. ± 1/2% .XX ± .004 .XXX ± .015, ± 1/2"  
 DWN FXY 14/9/73 SCALE: FULL  
 CHK \_\_\_\_\_ ENG \_\_\_\_\_  
 20A 2356 J

**MOSELEY ASSOCIATES, INC.**  
 SANTA BARBARA RESEARCH PARK  
 GOLETA, CALIFORNIA 93117  
**COMPONENT LAYOUT**  
**XMITR AUDIO**

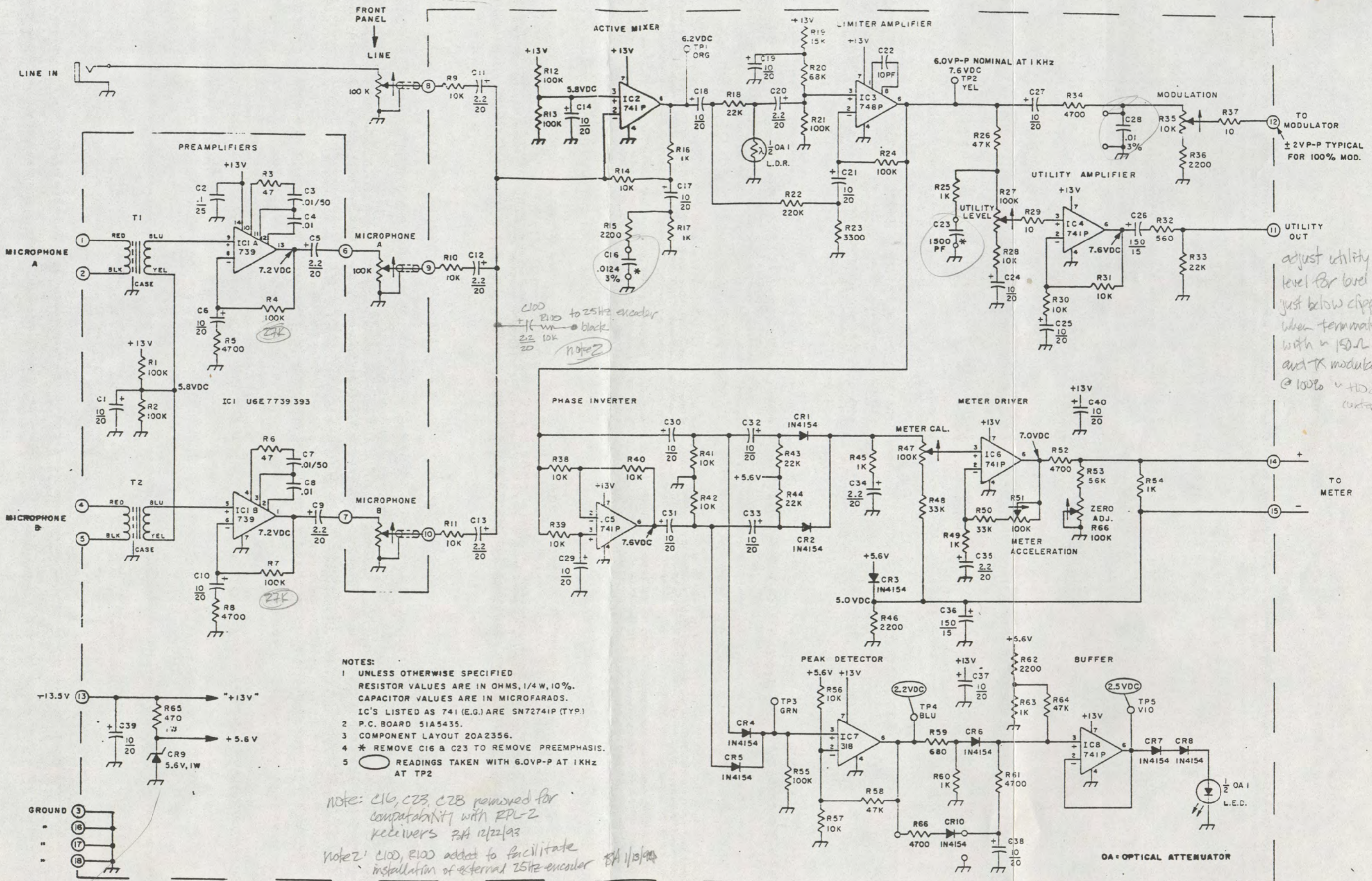

- NOTES:**
- UNLESS OTHERWISE SPECIFIED RESISTOR VALUES ARE IN OHMS, 1/4 W, 10%. CAPACITOR VALUES ARE IN MICROFARADS. IC'S LISTED AS 741 (E.G.) ARE SN72741P (TYP.)
  - P.C. BOARD 51A5435.
  - COMPONENT LAYOUT 20A2356.
  - \* REMOVE C16 & C23 TO REMOVE PREEMPHASIS.
  - READINGS TAKEN WITH 6.0VP-P AT 1KHZ AT TP2

*note: C16, C23, C28 removed for compatibility with RPL-2 receivers BA 12/2/93*

*note 2: C100, R100 added to facilitate installation of external 25Hz-encoder BA 1/13/94*

*note 3: changed R4 & R7 to 22K to lower gain of mic pre-amps BA 2/5/94*

*adjust utility level for level just below clipping when terminated with a 150Ω and TX modulated @ 100% w/ 10.88V (current mode)*

MOSELEY ASSOCIATES, INC.	
SCHEMATIC TRANSMITTER AUDIO	
DATE: 11/13/94	REV: 1
DESIGNER: J. L. MOSELEY	APP'D: J. L. MOSELEY
CHECKED: J. L. MOSELEY	DATE: 11/13/94
FILE: 91C6584	PROJECT: 91C6584

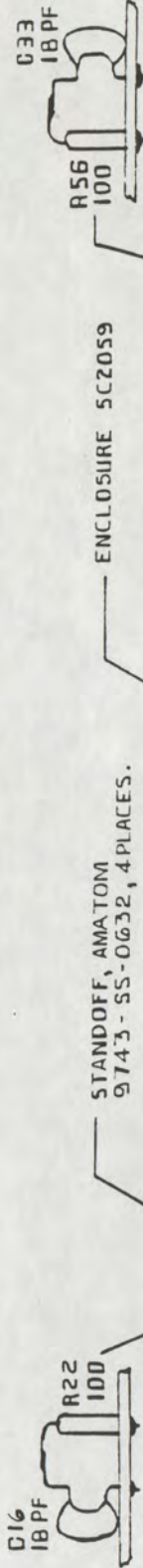

STANDOFF, AMATOM  
9743-SS-0632, 4 PLACES.

ENCLOSURE 5C2059

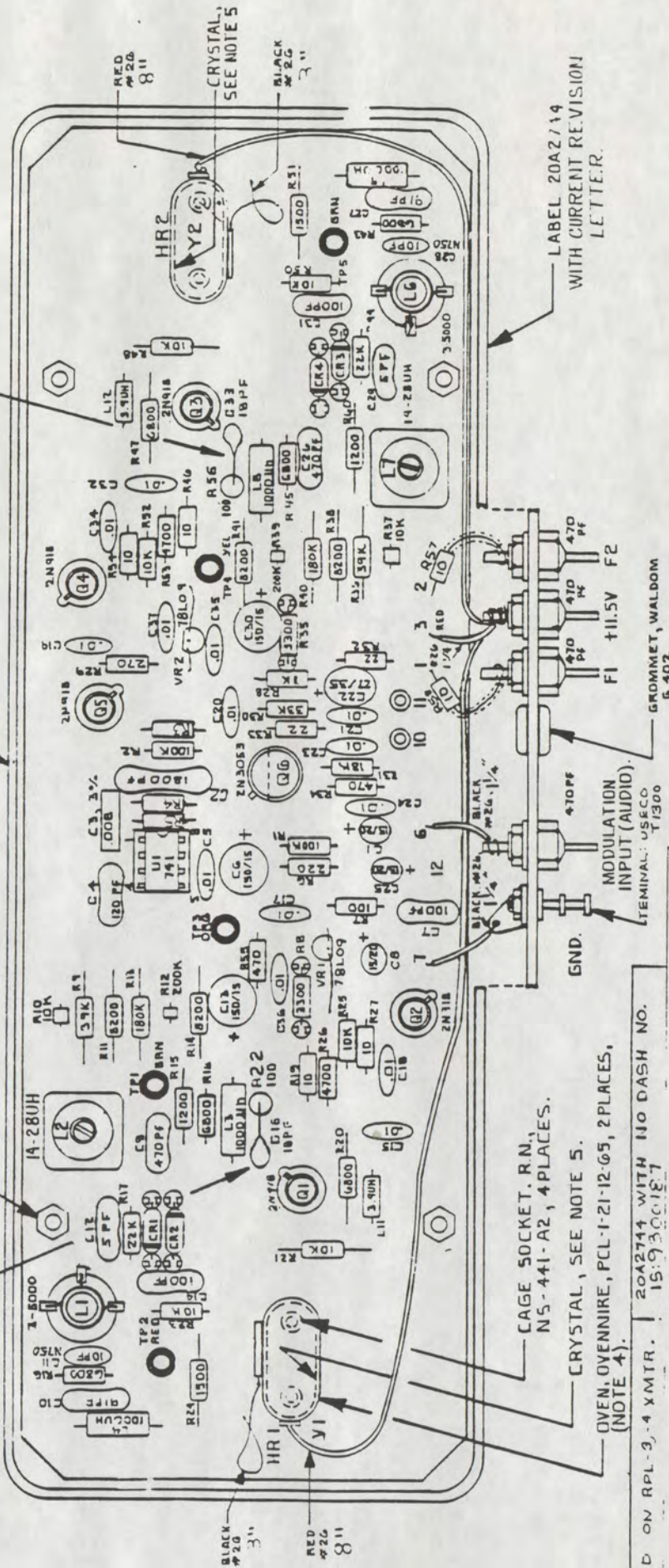

DETAILS L5 L10	CH
ADJ. R57, 58, VR1, VR2	
NEW PARTWORK	
ECO 30, 31, 81, 82	
1. 1. 1. LABEL	
ADD ITEM 3 TO CHART, ECO	
04 3138 SEP 25 '81 CAH	

MOBELEY ASSOCIATES, INC.		SANTA BARBARA RESEARCH PARK COTEITA, CALIFORNIA 93071	
<b>COMPONENT LAYOUT</b>			
XMTR 2 CHANNEL VCXO			
TOL. FRACT. ± 1/72	XX ± 8%	XX ± 0.1%	XX ± 1/2"
OWN JAM	22MART9	SCALE: FULL	
CHK	ENG		
			20A2744
			F

ITEM 1 - 7.5 KHZ LPF	18K	RPL-3A, RPL-4A	9301875
ITEM 2 - 15 KHZ LPF	8200 Ω	RPL-4B	9301359
ITEM 3 - 10 KHZ LPF	12K	RPL-4 (BBC)	9301367

- NOTES:
- UNLESS OTHERWISE SPECIFIED RESISTOR VALUES ARE IN OHMS. 1/4W. 10%. CAPACITOR VALUES ARE IN MICROFARADS.
  - P.C. BOARD 51A5821-12
  - SCHEMATIC 91C7164
  - HRI & HR2 ARE PROPORTIONAL CONTROL HEATERS.
  - FREQ. Y1, Y2  
300-320 MHZ 30A0661  
140-174 MHZ 30A0059  
215-240 MHZ 30A0060  
400-470 MHZ 30A0058

- DIODES ARE MV1624
- SOLDER ALL TERMINALS MOUNTED TO P.C.B. FAR SIDE.

\* installed

If You Didn't Get This From My Site,  
Then It Was Stolen From...  
[www.SteamPoweredRadio.Com](http://www.SteamPoweredRadio.Com)

USED ON RPL-3, 4 XMTR. | 20A2744 WITH NO DASH NO. |  
15:930C1E7

R3, R4, R5

18K

8200 Ω

12K

9301875  
9301359  
9301367

USE EMPTY HC 40U XTAL CAN IF ONLY ONE CHANNEL USED.

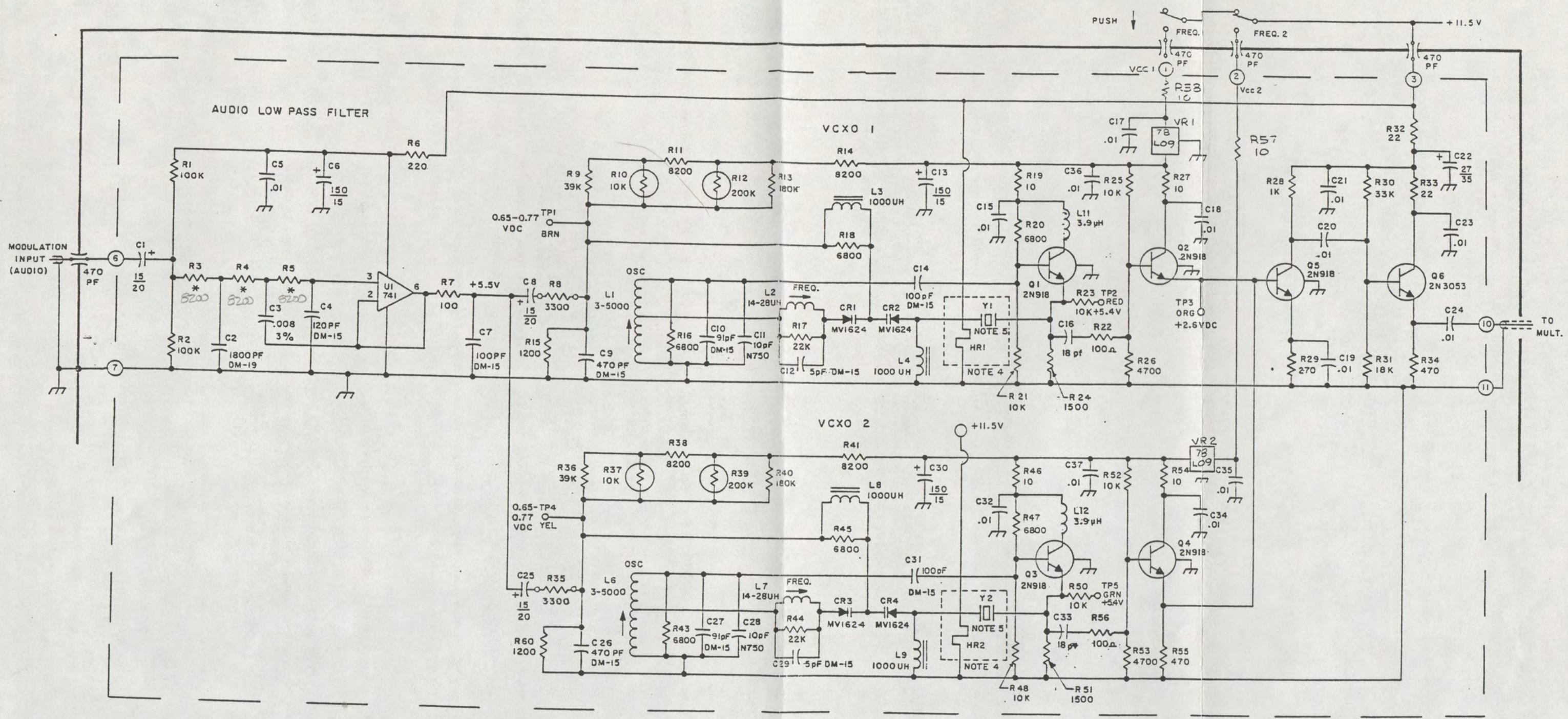

- NOTES:
- UNLESS OTHERWISE SPECIFIED, RESISTOR VALUES ARE IN OHMS, 1/4W, 10% CAPACITOR VALUES ARE IN MICROFARADS.
  - P.C. BOARD 51A5821-12
  - COMPONENT LAYOUT 20A2744.
  - HRI & HR2 ARE PROPORTIONAL CONTROL HEATERS.
  - | FREQUENCY   | Y1 & Y2 |
|-------------|---------|
| 140-170 MHz | 30A0059 |
| 215-240 MHz | 30A0060 |
| 420-470 MHz | 30A0058 |
| 300-330 MHz | 30A0061 |
  - R35 SELECTED AND INSTALLED BY TEST.

\* VARIABLE COMPONENTS

ITEM	VALUE	TYPE
ITEM 1	7.5 KHz LPF	18K RPL-3A, RPL-4A
ITEM 2	15 KHz LPF	* 8200Ω RPL-4B
ITEM 3	10 KHz LPF	12K RPL-4 (BBC)

If You Didn't Get This From My Site,  
Then It Was Stolen From...  
[www.SteamPoweredRadio.Com](http://www.SteamPoweredRadio.Com)

ADD RET, RES, VRI V12 V12		DATE	
MOSLEY ASSOCIATES, INC. SANTA BARBARA RESEARCH PARK GOLETA, CALIFORNIA 93017		DATE	
SCHEMATIC			
2 CHANNEL VCXO RPL-( ) XMTR			
TOL: FRACT. = 1/32 .XX = .020 .XXX = .010 <= 1/2"			
DWN   JAM   22 MAR 79   SCALE:			
CHK	ENG	91C7164   D	



L11-L12 SPACING  
1/8" MAX.

80 4 PLCS

7

SHIELD TO BE  
INSTALLED BY TEST

2  
3  
81

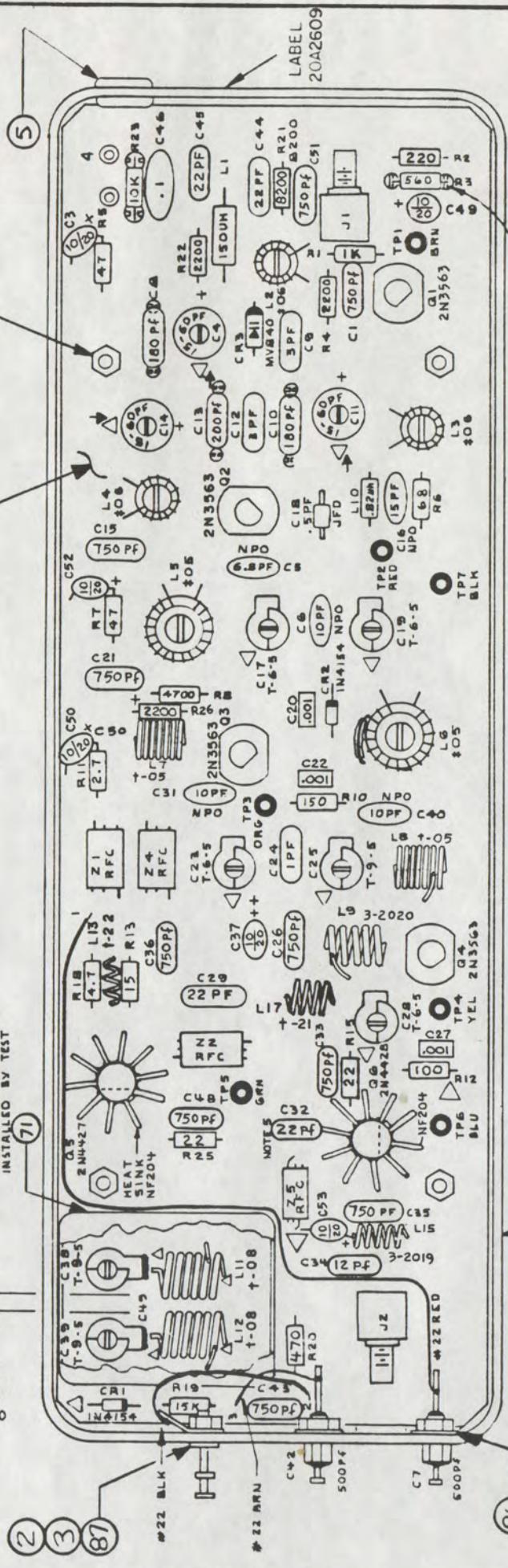

LABEL  
20A2609

MOUNT C2,001 CAPACITOR  
ABOVE R3

86 2 PLCS

NOTCH DENOTES  
↑ SIDE

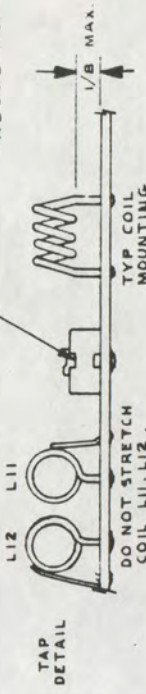

NOTES:

1. UNLESS OTHERWISE SPECIFIED  
RESISTOR VALUES ARE IN OHMS, 1/4W, 10%  
CAPACITOR VALUES ARE IN MICROFARADS.
2. †-DENOTES COIL 3-2001-( )  
‡ TORROID 3-3001-( )  
△ SOLDER BOTH SIDES OF P.C. BOARD.  
↗ ROTOR SIDE  
SOLDER ALL COMPONENTS TO GND PLANE WHERE POSSIBLE
3. P.C. BOARD 51A570B
4. SCHEMATIC 91C698D
5. INSTALL C32 1/8" OFF OF BOARD.

ITEM NO: 9300260

**MOSELEY ASSOCIATES, INC.**  
SANTA BARBARA RESEARCH PARK  
GOLETA, CALIFORNIA 93017

**COMPONENT LAYOUT**  
150MHZ MULT/DRIVER XMTR

TOL: FRACT. ± 1/32, .XX ± .030, .XXX ± .010, < ± 1/2°  
DWN L.I. 1 APRIL 77 SCALE: FULL  
CHK FXY 31 MAY 75  
ENG (J.D.P.)

20A2609 F

REVISIONS	DATE
A	ADD C53, R226 CHANGE C3, C15 C21, C25, C27, R13, R25 & L6 TAP ECO 898 30AUG 77
B	R25 WAS 10K, R1 WAS 56K. ECO 1135 20JUN 79 JAM
C	CHG'D C2, R20, R22, R27 FROM .01 L.F. PER ECO 903 3 MARCH 78 PHL
D	Z MAY T.B. ECO 943, L.I. ECO 1135 20JUN 79 JAM
E	ADDED ROTOR NOTE. ECO 1135 20JUN 79 JAM
F	UPDATE TO CO 51D DELETE EYELETS ECO 4303 6 DEC 84 CH
F2	REROUTED #22 BLK WIRE PC0198Z 12/19/80 RLG
F3	ADD USECO TERM TO DWG. RAG 80 PCD 1817 AFB.
F4	MGMT. APPR.

If You Didn't Get This From My Site,  
Then it Was Stolen From...  
[www.SteamPoweredRadio.Com](http://www.SteamPoweredRadio.Com)

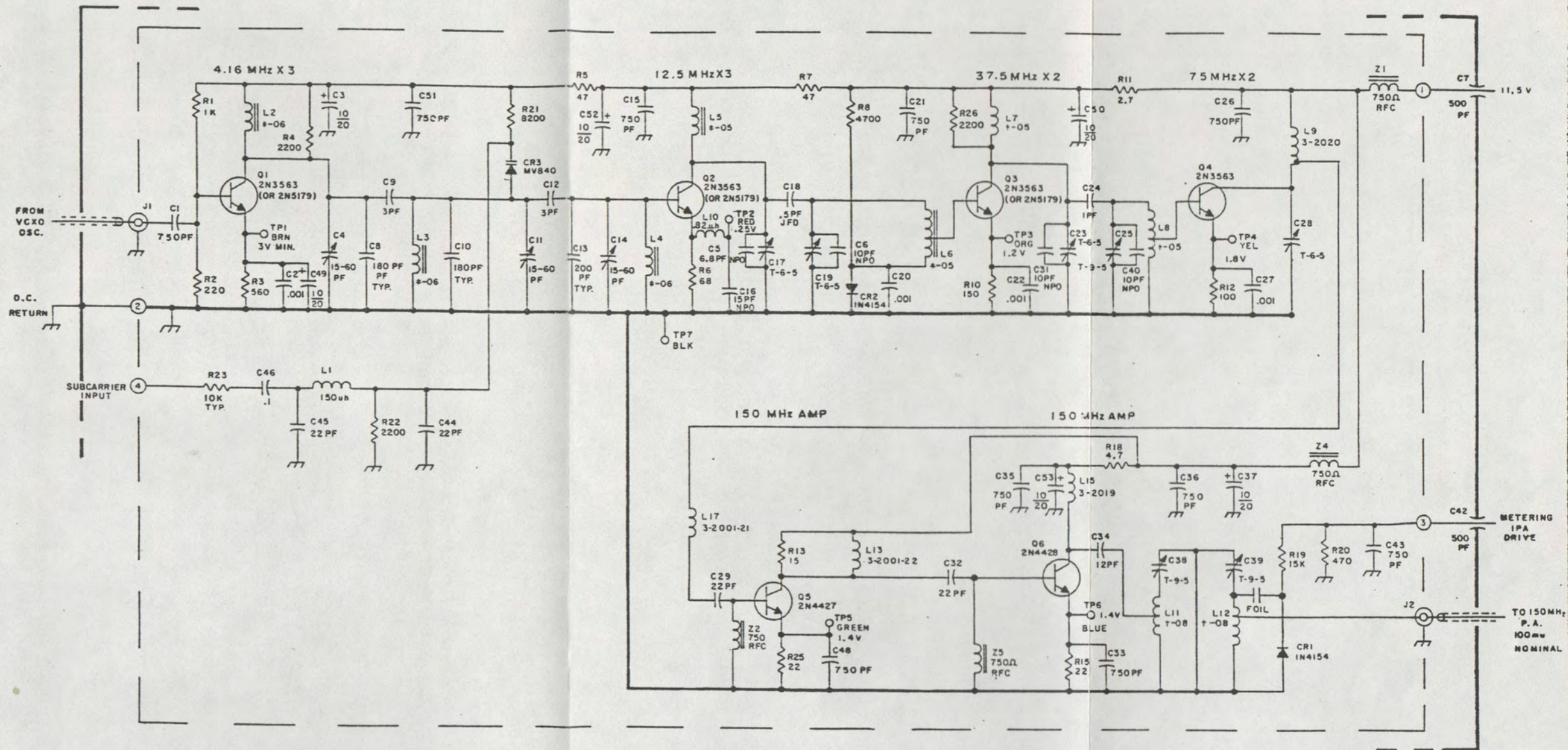

- NOTES:
- UNLESS OTHERWISE SPECIFIED  
RESISTOR VALUES ARE IN OHMS, 1/4W, 10%.  
CAPACITOR VALUES ARE IN MICROFARADS
  - T- DENOTES AIR COIL 3-2001-( )  
\* TOROID 3-3001-( )
  - P.C. BOARD 51A5708
  - COMPONENT LAYOUT 20A2609.
  - SUB CARRIER INPUT NOT USED FOR RPL

If You Didn't Get This From My Site,  
Then It Was Stolen From...  
[www.SteamPoweredRadio.Com](http://www.SteamPoweredRadio.Com)

<b>MOBELEY ASSOCIATES, INC.</b> SANTA BARBARA RESEARCH PARK GOLETA, CALIFORNIA 93117	
<b>SCHEMATIC</b> 150MHz MULT/DRIVER XMTR	
TOL. FRACT. ± 1/2% J1 ± 2% J2 ± 2% J3 ± 2% J4 ± 2% J5 ± 2% J6 ± 2% J7 ± 2% J8 ± 2% J9 ± 2% J10 ± 2% J11 ± 2% J12 ± 2% J13 ± 2% J14 ± 2% J15 ± 2% J16 ± 2% J17 ± 2% J18 ± 2% J19 ± 2% J20 ± 2% J21 ± 2% J22 ± 2% J23 ± 2% J24 ± 2% J25 ± 2% J26 ± 2% J27 ± 2% J28 ± 2% J29 ± 2% J30 ± 2% J31 ± 2% J32 ± 2% J33 ± 2% J34 ± 2% J35 ± 2% J36 ± 2% J37 ± 2% J38 ± 2% J39 ± 2% J40 ± 2% J41 ± 2% J42 ± 2% J43 ± 2% J44 ± 2% J45 ± 2% J46 ± 2% J47 ± 2% J48 ± 2% J49 ± 2% J50 ± 2% J51 ± 2% J52 ± 2% J53 ± 2% J54 ± 2% J55 ± 2% J56 ± 2% J57 ± 2% J58 ± 2% J59 ± 2% J60 ± 2% J61 ± 2% J62 ± 2% J63 ± 2% J64 ± 2% J65 ± 2% J66 ± 2% J67 ± 2% J68 ± 2% J69 ± 2% J70 ± 2% J71 ± 2% J72 ± 2% J73 ± 2% J74 ± 2% J75 ± 2% J76 ± 2% J77 ± 2% J78 ± 2% J79 ± 2% J80 ± 2% J81 ± 2% J82 ± 2% J83 ± 2% J84 ± 2% J85 ± 2% J86 ± 2% J87 ± 2% J88 ± 2% J89 ± 2% J90 ± 2% J91 ± 2% J92 ± 2% J93 ± 2% J94 ± 2% J95 ± 2% J96 ± 2% J97 ± 2% J98 ± 2% J99 ± 2% J100 ± 2%	DATE: 31 MAR 77 DRAWN: FXY CHECKED: FXY DESIGNED: FXY APPROVED: FXY
REV. NO. 1 REV. DATE 11/1/77 REV. BY FXY REV. DESCRIPTION: CHANGE R25 TO 22 OHMS REV. 2: CHANGE R25 TO 22 OHMS REV. 3: CHANGE R25 TO 22 OHMS REV. 4: CHANGE R25 TO 22 OHMS REV. 5: CHANGE R25 TO 22 OHMS REV. 6: CHANGE R25 TO 22 OHMS REV. 7: CHANGE R25 TO 22 OHMS REV. 8: CHANGE R25 TO 22 OHMS REV. 9: CHANGE R25 TO 22 OHMS REV. 10: CHANGE R25 TO 22 OHMS	91C6980

PRINT PHANTOM ITEMS  
 PRINT COMPONENTS  
 PRINT PHANTOM/COMPONENT COMMENTS

90M ITEM	COMPONENT & CROSS REF.	DESCRIPTION & COMMENT	DESCRIPTION XMTX 140/240MHZ 10W POW AMP-2 ENGR DRAW 2002374-2 U1	ENGINEERING DRAWING NUMBER	QUANTITY PER	ITEM UM TYP	OPT NBR	FIRST OP SEQ	LT ADJ	ITEM TYPE 1 UNIT MEAS EA	LOW LEVEL 03 PLANNER 504
04	2090017	COVER XMYR PWR AMP ENCL		05B2061-2 K	1.000	EA 2					
1	04 2110047	HEATSINK 140-240MHZ 10W PA TX		05B2079 K	1.000	EA 2					
2	04 2090009	ENCL PWR AMP XMTX 140/240		05B2061-1 K	1.000	EA 2					
3	04 3470002	PCB 150MHZ 10W PWR AMPLIFIER		51A5428-27 F	1.000	EA 9					
4	05 3250214	SKT XSTR/LAM		LST2202-2	1.000	EA 4					
5	04 3030301	CUNN SUB MIN RF R ANGLE JK J702		50-047-0000	1.000	EA 4					
6	04 3030293	CUNN SUB MIN RF REAR MT JK J701		50-045-0000	1.000	EA 4					
7	04 1230895	STDF 1/4 HEX 4.0 X 1 SS		9743-SS-0440	4.000	EA 4					
8	04 1130301	WSHR LK #8 EXT T SST		LOCKWASHER #8	2.000	EA 4					
9	05 1050624	WSHR LK #4 INTL T CD PL		LOCKWASHER #4	1.000	EA 4					
10	04 3290582	TERM		1300T 4.5	1.000	EA 4					
11	06 1050582	NUT HEX 4/40 SM PATT		NUT 4/40	1.000	EA 4					
12	05 1130277	NUT HEX 8/32 1/4 FLATS SST		NUT 8/32 SM	2.000	EA 4					
13	05 1050103	SCR PNDH PPHS 4/40 X 3/16 SS		BINDER HEAD	6.000	EA 4					
14	04 4020368	FERRUX-CUBE 850 OHM Z701,Z704,Z705		VK 200 20/48	3.000	EA 4					
15	04 3640091	XT NPC3-12 010W470M017V01A Q701		C3-12	1.000	EA 4					
16	04 3630365	XT NP2N5946 037W 036V02A Q702		2N5946	1.000	EA 4					
17	06 3600145	D10 IN4154 25V 4NS SI D035 CR701,CR702		IN4154	2.000	EA 4					
18	04 4010526	COIL AIR 3T 208US 21 3/8 LH L705		3-2018 N/C	1.000	EA 1					
19	04 4010310	COIL AIR 3T 18BUS 19 L701		3-2001-30 F1	1.000	EA 1					
20	04 4010039	COIL AIR 4T 16BUS 02 3/8 LH L702,L704		3-2001-02 F1	2.000	EA 1					
21	04 4010021	COIL AIR 3T 16BUS 01 3/8 LH L706,L707,L708		3-2001-01 F1	3.000	EA 1					
22	04 2060009	GROUND SIP 10W PA XMTX		05A2098-1 C	2.000	EA 2					

MOSELEY ASSOC SINGLE LEVEL BILL - REFERENCE NUMBER SEQUENCE

PRINT PHANTOM ITEMS  
PRINT COMPONENTS  
PRINT PHANTOM/COMPONENT COMMENTS

BOM ITEM	LL CD	COMPONENT & CROSS REF.	DESCRIPTION & COMMENT	ENGINEERING DRAWING NUMBER	QUANTITY PER	ITEM UM TYP	OPT NBR	FIRST OP SEQ	LT ADJ	EFFECTIVE DATES FROM TO
23	05	4590063	RES 1 OHM 2W 5% R710	BWH 1 2W 5%	1.000	EA	4			
24	04	4590022	RES .16 OHM 2W 5% R705	BWH .16 2W 5%	1.000	EA	4			
26	04	4460150	RES 1.3K OHM 1/4W 5% R702	RC07GF132J	1.000	EA	4			
27	05	4430013	RES 100 OHM 1W 10% OR 5% R703, R711	RC32GF101K	2.000	EA	4			
28	05	4410403	RES 18K OHM 1/4W 10% R706, R709	RC07GF182K	2.000	EA	4			
29	06	4410122	RES 100 OHM 1/4W 10% R707, R708	RC07GF101K	2.000	EA	4			
30	06	4410080	RES 47 OHM 1/4W 10% R701, R704	RC07GF470K	2.000	EA	4			
31	05	4370169	CAP PC MIN VAR 15-60PF C708	538-011F	1.000	EA	4			
32	04	4370144	CAP PC MIN VAR 5.5-18PF C701, C703	538-011A	2.000	EA	4			
33	04	4370086	CAP PC MT VAR 24.5-2.4PF C712, C713	189-0509-005	2.000	EA	4			
34	05	4350088	CAP FD THRU 500PF C723, C724, C725, C726	2425001X5U0501A	4.000	EA	4			
35	05	4310108	CAP CER DISC .001/1KV C704, C710, C718, C719, C720, C721	00-102G	6.000	EA	4			
36	05	4280178	CAP EPOX-DIP 150/15V C705, C711	196D157X00151E4	2.000	EA	4			
37	04	4240123	CAP GL 1000PF C706, C709	UY04-102K	2.000	EA	4			
38	04	1150176	LUG #10 LKG	T-236	4.000	EA	4			
39	04	4240040	CAP GL 20PF C715, C716	UY01-200J	2.000	EA	4			
40	04	4240024	CAP GL 10PF C717	UY01-100J	1.000	EA	4			
41	04	4210225	CAP MICA DIP 68PF 5% C707	DM-15-680J	1.000	EA	4			
42	06	1640671	W STRD 22GA WHITE-YELLOW	BU-730-22#94	.420	FT	4			
43	06	1640663	W STRD 22GA WHITE-ORANGE	BU-730-22#93	.330	FT	4			
44	06	1640655	W STRD 22GA WHITE-RED	BU-730-22#92	.920	FT	4			
45	06	1640390	W STRD 22GA RED	BU-730-22#2	.580	FT	4			
46	05	1641927	W BUSS 22GA	298	.020	FT	4			

PRINT PHANTOM ITEMS  
 PRINT COMPONENTS  
 PRINT PHANTOM/COMPONENT COMMENTS

PARENT ITEM 9300583 CROSS REF ITEM 04 1230291 DESCRIPTION XMTR 140/240MHZ 10W POW AMP-2 ENGR DRAW 20D2374-2 U1 BATCH QTY 1 ITEM TYPE 1 LOW LEVEL 03 UNIT MEAS EA PLANNER 504

BOM ITEM	LL COMPONENT & CU CROSS REF.	DESCRIPTION & COMMENT	ENGINEERING DRAWING NUMBER	QUANTITY PER	ITEM UM TYP	OPT NBR	FIRST OP SEQ	LT ADJ	EFFECTIVE DATES FROM TO
48	04 1230291	SPCR 1/4 HEX 4-40 X 1 BRASS	2334	2.000	EA	4			
49	05 1050145	SCR PNHD PHPS 4/40 X 5/16 SS	BINDER HEAD	2.000	EA	4			

PRINT PHANTOM ITEMS  
PRINT COMPONENTS  
PRINT PHANTOM/COMPONENT COMMENTS

PARENT ITEM CROSS REF ITEM DESCRIPTION XMTX 140/240MHZ 10W POW AMP-3 BATCH QTY 1 ITEM TYPE 1 LOW LEVEL 03  
9300591 ENGR DRAW 20D2374-3 U1

BOU ITEM	LL CD	COMPONENT & CROSS REF.	DESCRIPTION & COMMENT	ENGINEERING DRAWING NUMBER	QUANTITY PER	ITEM UM TYP	OPT NBR	FIRST OP	LT ADJ	EFFECTIVE DATES FROM TO
04	1150184		LUG #10 PLAIN	I-243	4.000	EA	4			
04	2090017		COVER XMTX PWR AMP ENCL	05B2061-2 K	1.000	EA	2			
04	2110047		HEATSINK 140-240MHZ 10W PA IX	05B2079 K	1.000	EA	2			
04	2090009		ENCL PWR AMP XMTX 140/240	05B2061-1 K	1.000	EA	2			
04	3470002		PCB 150MHZ 10W PWR AMPLIFIER	51A5428-27 F	1.000	EA	9			
05	3250214		SKT XSTR/LAM	LST2202-2	1.000	EA	4			
04	3030301		CUNN SUB MIN RF R ANGLE JK J702	50-047-0000	1.000	EA	4			
04	3030293		CUNN SUB MIN RF REAR MT JK J701	50-045-0000	1.000	EA	4			
04	1230895		STDF 1/4 HEX 4.00 X 1 SS	9743-SS-0440	4.000	EA	4			4/14/82
04	1130301		WSHR LK #8 EXT T SST	LOCKWASHER #8	2.000	EA	4			
05	1050624		WSHR LK #4 INTL T CD PL	LOCKWASHER #4	1.000	EA	4			
04	3290582		TERM	1300T 4.05	1.000	EA	4			
06	1050582		NUT HEX 4/40 SM PATT	NUT 4/40	1.000	EA	4			
05	1130277		NUT HEX 8/32 1/4 FLATS SST	NUT 8/32 SM	2.000	EA	4			
05	1050103		SCR PNDH PHPS 4/40 X 3/16 SS	BINDER HEAD	6.000	EA	4			
04	4020368		FERROX-CUBE 850 OHM Z701,Z704,Z705	VK 200 20/4B	3.000	EA	4			
04	3640091		XT NPC3-12 010W470M01V01A Q701	C3-12	1.000	EA	4			
04	3630365		XT NP2N5946 037W 036V02A Q702	2N5946	1.000	EA	4			
06	3600145		D10 IN4154 25V 4NS SI D035 CR701,CR702	IN4154	2.000	EA	4			
04	4010526		COIL AIR 3T 20BUS 21 378 LH L705	3-2018 N/C	1.000	EA	1			
04	4010310		COIL AIR 3T 18BUS 19 L701	3-2001-30 F1	1.000	EA	1			
04	4010039		COIL AIR 4T 16BUS 0 L702,L704	3-2001-02 F1	2.000	EA	1			
04	4010021		COIL AIR 3T 16BUS 0 L706,L707,L708	3-2001-01 F1	3.000	EA	1			

PRINT PHANTOM ITEMS  
 PRINT COMPONENTS  
 PRINT PHANTUM/COMPONENT COMMENTS

PARENT ITEM CROSS REF ITEM DESCRIPTION XMTR 140/240MHZ 10W POW AMP-3 BATCH QTY ITEM TYPE 1 LOW LEVEL 03  
 9300591 ENGR DRAW 2002374-3 U1

BOM ITEM	LL COMPONENT & CD CROSS REF.	DESCRIPTION & COMMENT	ENGINEERING DRAWING NUMBER	QUANTITY PER	ITEM UM TYP	OPT NBR	FIRST OP SEQ	LI ADJ	EFFECTIVE DATES FROM TO
22	04 2060069	GROUND STP 10W PA XMTR	05A2098-1 C	2.000	EA 2				
23	05 4590063	RES 1 OHM 2W 5% R710	BWH 1 2W 5%	1.000	EA 4				
24	04 4590022	RES .16 OHM 2W 5% R705	BWH .16 2W 5%	1.000	EA 4				
25	04 4470092	RES 1.5K OHM 1/2W 5% R702	RC20GF152K	1.000	EA 4				
27	05 4430013	RES 100 OHM 1W 10% OR 5% R703,R711	RC32GF101K	2.000	EA 4				
28	05 4410403	RES 18K OHM 1/4W 10% R706,R709	RC07GF182K	2.000	EA 4				
29	06 4410122	RES 100 OHM 1/4W 10% R707,R708	RC07GF101K	2.000	EA 4				
30	06 4410080	RES 47 OHM 1/4W 10% R701,R704	RC07GF470K	2.000	EA 4				
31	05 4370169	CAP PC MIN VAR 15-60PF C708	538-011F	1.000	EA 4				
32	04 4370144	CAP PC MIN VAR 5.5-18PF C701,C703	538-011A	2.000	EA 4				
33	04 4370086	CAP PC MT VAR 24.5-2.4PF C712,C713	189-0509-005	2.000	EA 4				
34	05 4350088	CAP FU THRU 500PF C723,C724,C725,C726	2425001X5U0501A	4.000	EA 4				
35	05 4310108	CAP CER DISC .001/1KV C704,C710,C718,C719,C720,C721	DD-102G	6.000	EA 4				
36	05 4280178	CAP EPDX-DIP 150/15V C705,C711	1960157X0015TE4	2.000	EA 4				
37	04 4240123	CAP GL 1000PF C706,C709	UY04-102K	2.000	EA 4				
39	04 4240040	CAP GL 20PF C715,C716	UY01-200J	2.000	EA 4				
40	04 4240024	CAP GL 10PF C717	UY01-100J	1.000	EA 4				
41	04 4210225	CAP MICA DIP 68PF 5% C707	DM-15-680J	1.000	EA 4				
42	06 1640671	W STRD 22GA WHITE-YELLOW	BU-730-22*94	.420	FT 4				
43	06 1640663	W STRD 22GA WHITE-ORANGE	BU-730-22*93	.330	FT 4				
44	06 1640655	W STRD 22GA WHITE-RED	BU-730-22*92	.920	FT 4				
45	06 1640390	W STRD 22GA RED	BU-730-22*2	.580	FT 4				

PRINT PHANTOM ITEMS  
 PRINT COMPONENTS  
 PRINT PHANTOM/COMPONENT COMMENTS

PARENT ITEM 9300591 CROSS REF ITEM DESCRIPTION XMTR 140/240MHZ 10W POW AMP-3 ENGR DRAW 20D2374-3 UI BATCH QTY 1 ITEM TYPE 1 UNIT MEAS EA LOW LEVEL 03 PLANNER 504

COM ITEM	LL CD	COMPONENT & CROSS REF.	DESCRIPTION & COMMENT	ENGINEERING DRAWING NUMBER	QUANTITY PER	ITEM UM TYP	OPT NBR	FIRST OP SEQ	LT ADJ	EFFECTIVE DATES FROM TO
46	05	1641927	W BUSS 22GA	298	0.020	FT	4			
48	04	1230291	SPCR 1/4 HEX 4-40 X 1 BRASS	2334	2.000	EA	4			
49	05	1050145	SCR PNHD PHPS 4/40 X 5/16 SS BINDER HEAD		2.000	EA	4			



\* R702

ITEM 2	1300, 5%, 1/4 W
ITEM 3	1500, 5%, 1/2 W

(ITEM 1 DELETED)

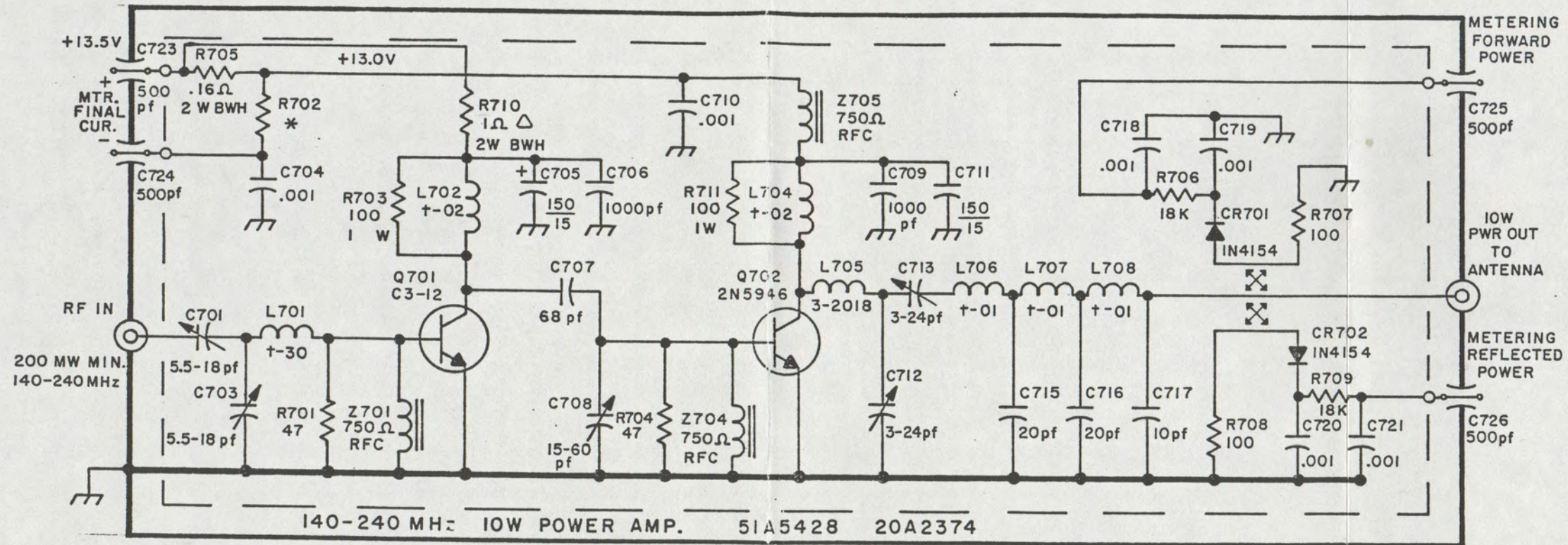

NOTES:

1 UNLESS OTHERWISE SPECIFIED  
RESISTOR VALUES ARE IN OHMS, 1/4 W, 10%.  
CAPACITOR VALUES ARE IN MICROFARADS.

2 +- DENOTES AIR COIL 3-2001-( ).

3 P.C. BOARD 51A5428.

4 COMPONENT LAYOUT 20A2374.

5 Δ DENOTES SELECTED VALUE

6. 2N6801 can be substituted for 2N5946 as a lower gain, lower frequency replacement. C3-12 no longer available

If You Didn't Get This From My Site,  
Then It Was Stolen From...  
www.SteamPoweredRadio.Com

CHG. L701 WAS +-33 12 APRIL 76 EGO 1086 A.J.B. C725F75&C723F724 WAS 470FF 2702 1300 WAS 100W 38 OCT 76 EGO 0971 L.L.		R702 WAS 1K5% 1/2W EGO 158 23AUG76 JAM R710 WAS E-2-2, 1/2W. R702 WAS 2K & 2.4K FOR ITEMS 2 & 3. EGO 852 29NOV77 F.X.Y.		C701 WAS 12 PF R702 WAS 1800G. R705 WAS W MOVE R710. EGO 878. 20APR77 R.X.Y.		PART AND VALUE CHANGES PER E.C.O. 843 8 OCT 76 T.A.		REDRAWN ADD 94L-505 220MHZ & EGO T82 CHNGS. 2 JAN 75 F.X.Y.		REVISIONS DATE MGMT. APPR.	
MOSELEY ASSOCIATES, INC. SANTA BARBARA RESEARCH PARK GOLETA, CALIFORNIA 93017											
SCHEMATIC XMTR 140-240 MHz 10W POWER AMP.											
TOL: FRACT. ± 1/32, .XX ± .030, .XXX ± .010, < ± 1/2°											
DWN	FX Y	2 JAN 76	SCALE:								
CHK											
ENG											
I	H	G	F	E	D	C	91B6604 I				

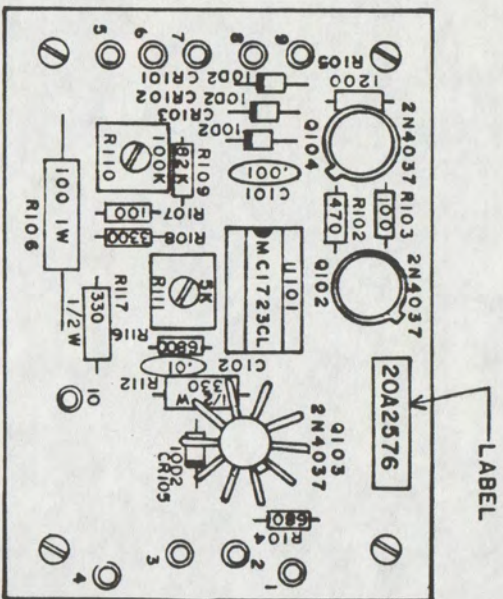

- NOTES
1. UNLESS OTHERWISE SPECIFIED ALL RESISTOR VALUES ARE IN OHMS 1/4W, 10% CAPACITOR VALUES ARE IN MICROFARADS.
  2. P. C. BOARD 51A5711
  3. SCHEMATIC 91B6908

G	DELETE 2 ITEM AND ITEM 22 ON PARTS LIST ECO 3798 14 MAR 83 C.H.
F	DELETE NOTE 4 PCO 3457 12 APR 82 CH
E	U101 READED IC 5 JUL 80 ECO 1759 A.J.B.
D	ADD R117. ECO 1064 & 1066 CHNG. NOTE 4 10 JAN 79. F.X.Y.
C	REMOVE R113-15, C104, Q105 & 6. ADD ITEM 2 ECO 857 7 JUNE 77 JAM.
B	R112 WAS 68Ω. R102 WAS 4700Ω R114 WAS 6800. R115 WAS 8200. ECO 850. 20 DEC 76 F.X.Y.
A	ADD R102 VALUE 15 DEC 76 L.C.
	Q106 WAS 2N6236 6 AUG 76 L.I.

REVISIONS	DATE
MGMT. APPR.	

ITEM NO: 9202573

**MOSELEY ASSOCIATES, INC.**  
SANTA BARBARA RESEARCH PARK  
GOLETA, CALIFORNIA 93017

**COMPONENT LAYOUT**  
X MTR P.S. REG

TOL: FRACT. ± 1/32	.XX ± .030	.XXX ± .010	± 1/2°
DWN	L.I.	30 APR 76	SCALE: FULL
CHK	FXY	7 MAY 76	
ENG	181002	5 6 2	20A2576

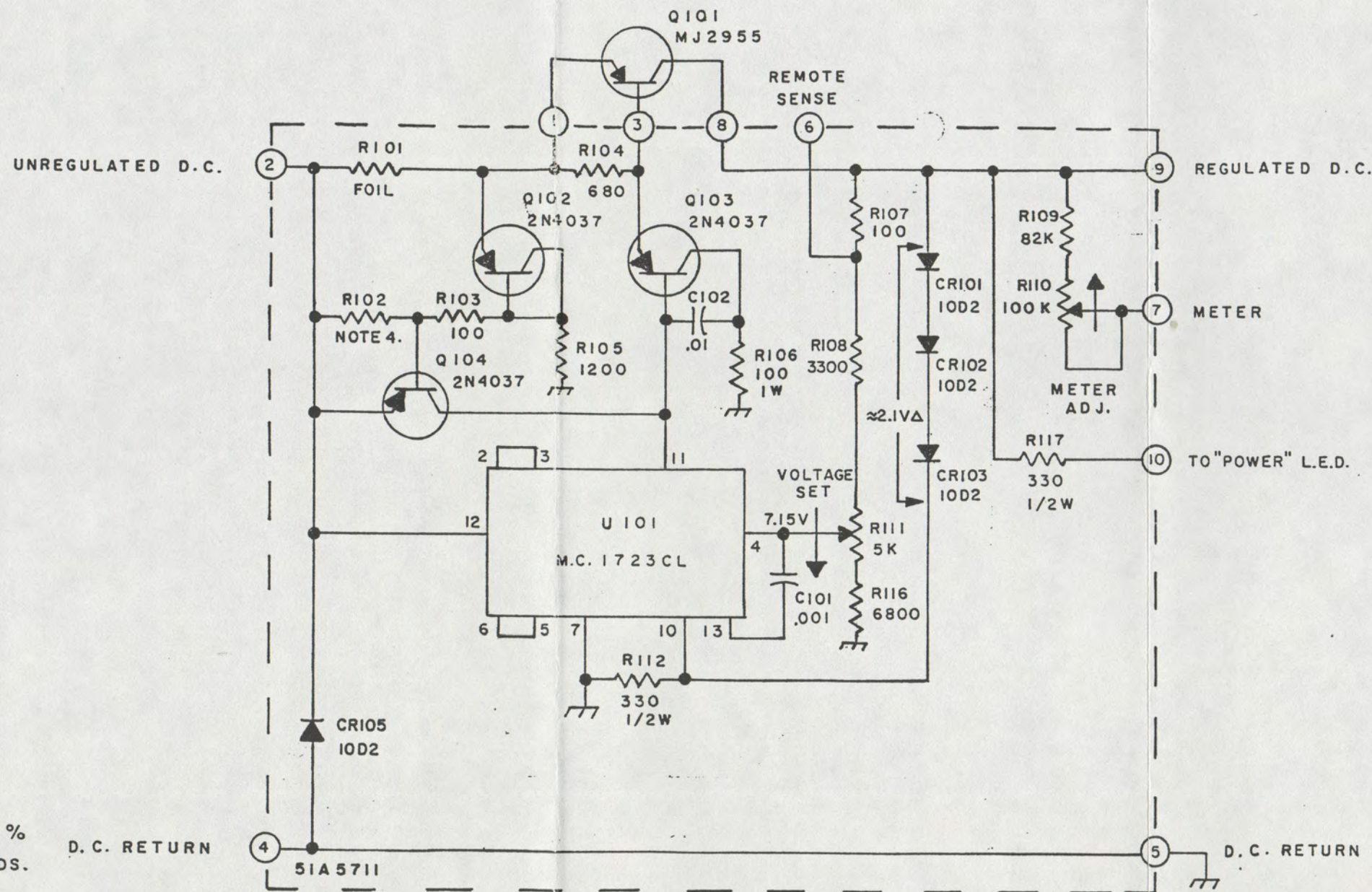

- NOTES:
- UNLESS OTHERWISE SPECIFIED RESISTOR VALUES ARE IN OHMS 1/4 W, 10% CAPACITOR VALUES ARE IN MICROFARADS.
  - P.C. BOARD 51A5711
  - COMPONENT LAYOUT 20A2576
  - R102 SELECTED FOR CURRENT LIMITING. 470Ω TYP.

D.C. RETURN

51A5711

D.C. RETURN

If You Didn't Get This From My Site,  
Then It Was Stolen From...

www.SteamPoweredRadio.Com

PRINTED ON DIETERICH-POST CLEARPRINT 1020-8

DELETE: NOTE 5 AND CR106 ECO 3798 14 MAR 83 CH.		U101 READED IC 5 JUN 80 ECO 1789 A.D.		ADD R117. CHNG. NOTES, ECO'S 1064 & 1065. 18 JAN 79. F.X.Y.		DELETE R113 - 15, Q105 & E CR104. ADD NOTE 5. ECO 287 7 JUN 77 - J.A.M.		R117 WAS 300Ω. ADD RES VALUE. ECO 850. 20 DEC 78. F.X.Y.		CR106 WAS 2N4036 L.I. 9 AUG 76		DATE		REVISIONS		MGMT. APPR.		 SANTA BARBARA RESEARCH PARK GOLETA, CALIFORNIA 93017											
TOL: FRACT. ± 1/32, .XX ± .030, .XXX ± .010, < ± 1/2"												SCALE: NONE																	
DWN		L.I.		28APR76		6MAY76		91B6908		F																			
CHK		FX Y		6MAY76		91B6908		F																					
ENG		J. J. J.		6MAY 8		91B6908		F																					

21A2379 BI

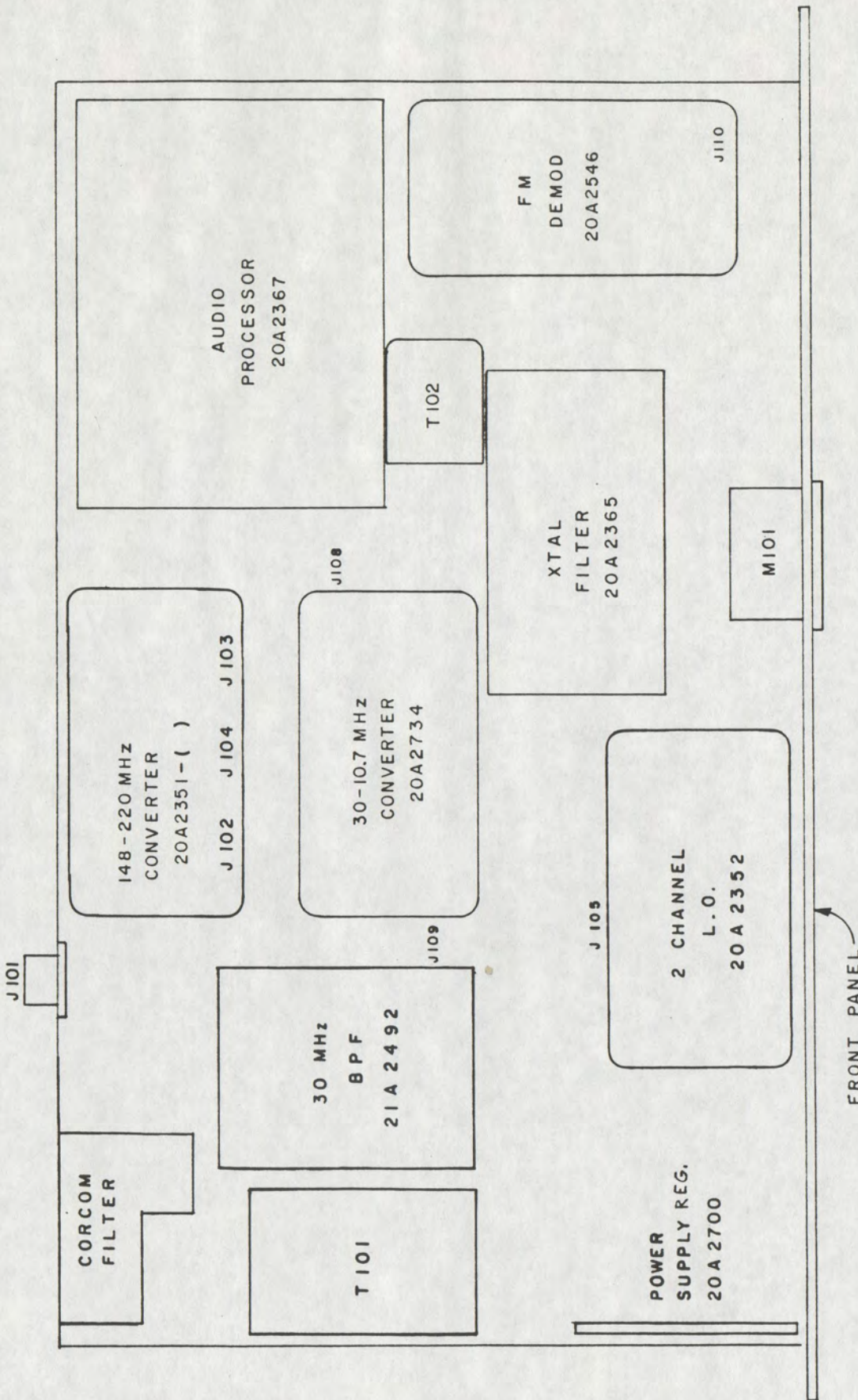

**MOSELEY ASSOCIATES, INC.**  
 SANTA BARBARA RESEARCH PARK  
 GOLETA, CALIFORNIA 93017

**FIGURE 2**  
**RPL-3 RECEIVER LAYOUT**

TOL: FRACT. ± 1/32, .XX ± .030, .XXX ± .010, < ± 1/2°	DWN	F X Y	6/28/73	SCALE: 1/2
CHK	ENG			

MGMT. APPR. \_\_\_\_\_

REVISIONS	DATE
D	PER ECD 746 JHM 20 NOV 75
A	FM DEMOD WAS 20A2366 RELOCATED T102 20A2364 WAS 20A2350
B	PC0145239-11-16-79 ASE 25 JUN 80 BWF 1762
	CHANGES PER ECD

21A2379 BI

If You Didn't Get This From My Site,  
 Then It Was Stolen From...  
[www.SteamPoweredRadio.Com](http://www.SteamPoweredRadio.Com)

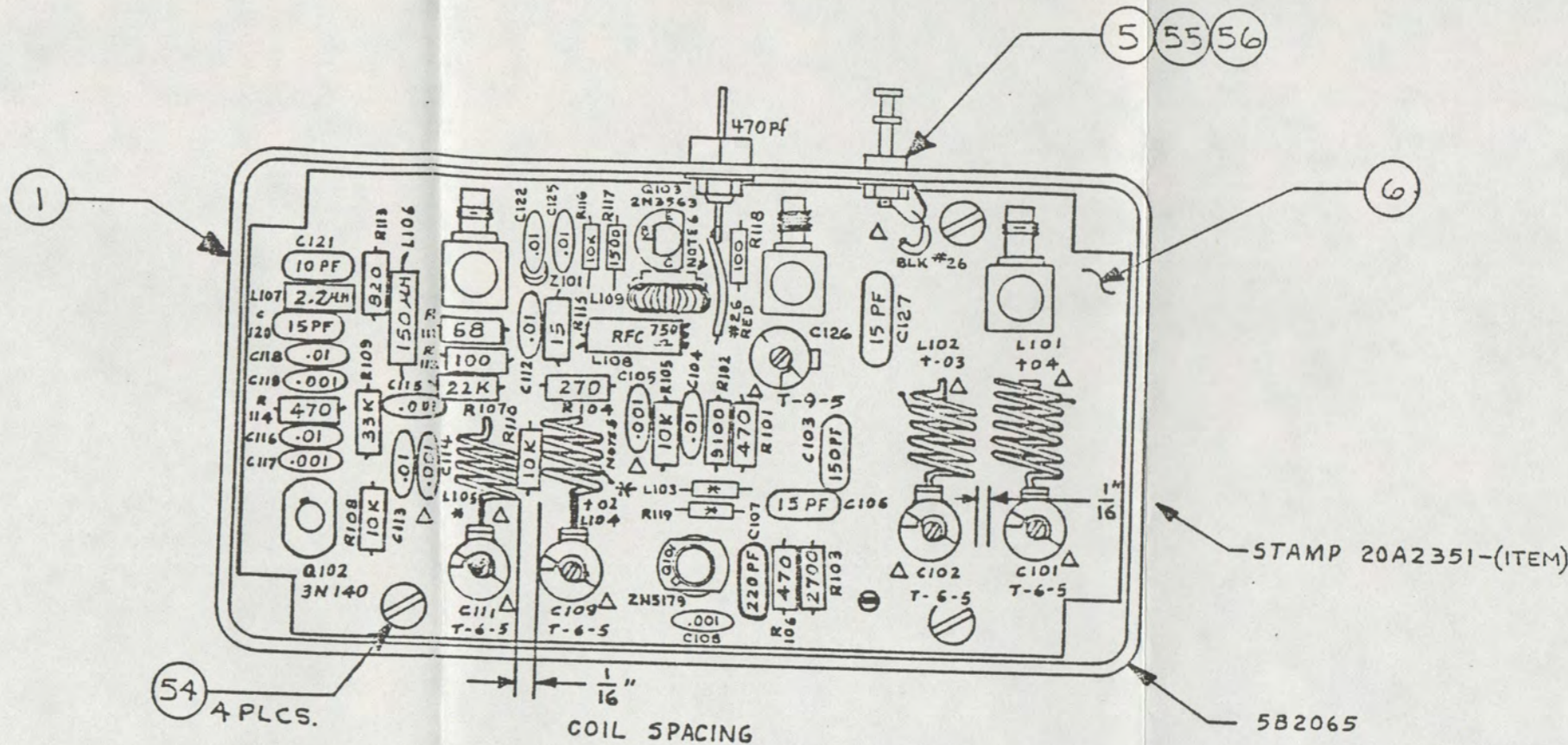

NOTES:

- 1 UNLESS OTHERWISE SPECIFIED RESISTOR VALUES ARE IN OHMS 1/4W.10% CAPACITOR VALUES ARE IN MICROFARADS
- 2 P. C. BOARD 51A 5444
- 3 SCHEMATIC 91A 657B
- 4 † DENOTES DRW 3-2001
- 5 \*TAP CONNECTION, L104

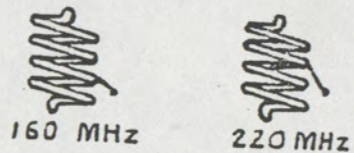

- 6 L109 IS 3-3001-13. R120 (4700Ω) IS IN PARALLEL WITH L109 AND MOUNTS ON BOTTOM SIDE OF BOARD.
- 7 VARIABLE CAPACITORS & AIR COILS THAT CONNECT TO GROUND MUST BE SOLDERED ON BOTH SIDES OF BOARD.
- 8 Δ DENOTES SOLDER ON BOTH SIDES OF BOARD.

	*	L104	L103	L105	R119
ITEM 1	160 MHZ	SEE NOTE 5	1.5 μH	3-2001-02	1200
ITEM 2	220 MHZ	" " "	.56 μH	3-2001-01	2200

ITEM NO: - 2: 9300633  
ITEM NO: - 1: 9300625

UPDATE TO CO. STD. ECO 4-276 19NOV84 CH	DATE	2/21/73
ADD COIL SPACING, CHANGE Q103 CONFIG. 11 MAY 78 F.X.Y.	REVISIONS	
Q101 (ITEM 2) WAS 2N3880 25AUG 76 BRREV D L.I.	MGMT. APPR.	
ADD R120 & Z101, L103 WAS .82 μH (160MHZ) ADD NOTES G-B ECO 6-6-B. 5 JUL 74 F.X.Y.		
BOARD REV.C. ADD C125-7, L109 & R119. REMOVE C125 Z101 & C110. ECO 6-47 22APR 74 F.X.Y.		
160MHZ: L103 WAS .82μH. C107 C110 & R105 NOW *		
ECO 6-33. 11 MART 74 F.X.Y.		
ADD Z101. ECO 5B7		

**MOSELEY ASSOCIATES, INC.**  
SANTA BARBARA RESEARCH PARK  
GOLETA, CALIFORNIA 93017

**COMPONENT LAYOUT**  
**148-220MHZ CONVERTER RCVR.**

TOL: FRACT. ± 1/32, .XX ± .030, .XXX ± .010, Δ ± 1/16"

DWN	R.A.	1-29-73	SCALE: FULL
CHK	FXY	1/30/73	
ENG	S.M.	30/4/73	20A 2351   G

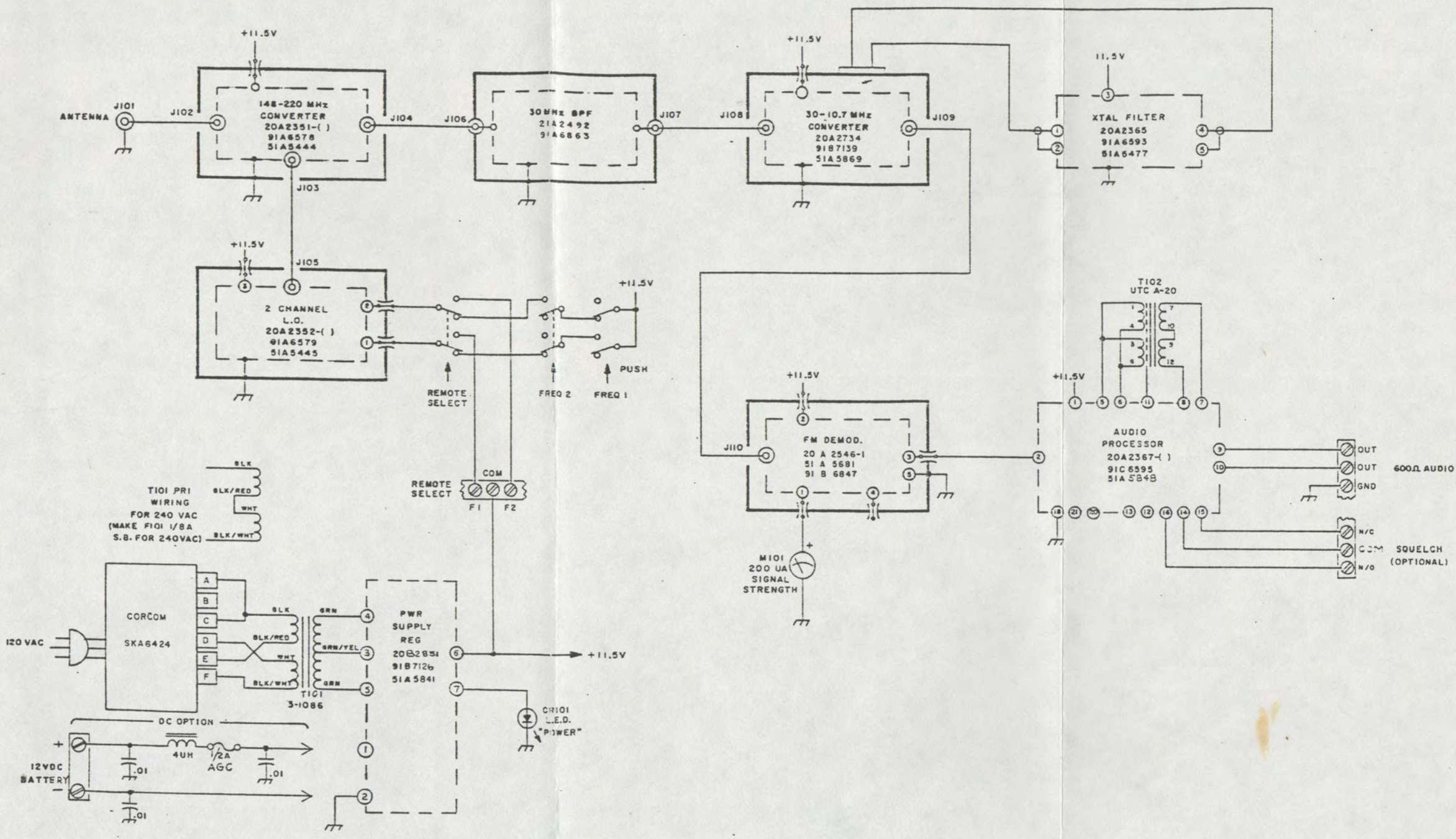

NOTES  
 1 P.C. BOARDS ARE SHOWN IN DASH LINES.  
 20 PREFIX IS MODULE NUMBER. - ( ) DETERMINES FREQUENCY.  
 91 PREFIX IS SCHEMATIC DRAWING NUMBER.  
 51 PREFIX IS P.C. BOARD NUMBER.

If You Didn't Get This From My Site,  
 Then It Was Stolen From...  
[www.SteamPoweredRadio.Com](http://www.SteamPoweredRadio.Com)

REMOVED RIBS FOR REVISIONS AND CAN BE REUSED. ECU 1548 ELIMINATED. D23X A, B, C, D, E, F, G, H, I, J, K, L, M, N, O, P, Q, R, S, T, U, V, W, X, Y, Z, AA, AB, AC, AD, AE, AF, AG, AH, AI, AJ, AK, AL, AM, AN, AO, AP, AQ, AR, AS, AT, AU, AV, AW, AX, AY, AZ, BA, BB, BC, BD, BE, BF, BG, BH, BI, BJ, BK, BL, BM, BN, BO, BP, BQ, BR, BS, BT, BU, BV, BW, BX, BY, BZ, CA, CB, CC, CD, CE, CF, CG, CH, CI, CJ, CK, CL, CM, CN, CO, CP, CQ, CR, CS, CT, CU, CV, CW, CX, CY, CZ, DA, DB, DC, DD, DE, DF, DG, DH, DI, DJ, DK, DL, DM, DN, DO, DP, DQ, DR, DS, DT, DU, DV, DW, DX, DY, DZ, EA, EB, EC, ED, EE, EF, EG, EH, EI, EJ, EK, EL, EM, EN, EO, EP, EQ, ER, ES, ET, EU, EV, EW, EX, EY, EZ, FA, FB, FC, FD, FE, FF, FG, FH, FI, FJ, FK, FL, FM, FN, FO, FP, FQ, FR, FS, FT, FU, FV, FW, FX, FY, FZ, GA, GB, GC, GD, GE, GF, GG, GH, GI, GJ, GK, GL, GM, GN, GO, GP, GQ, GR, GS, GT, GU, GV, GW, GX, GY, GZ, HA, HB, HC, HD, HE, HF, HG, HH, HI, HJ, HK, HL, HM, HN, HO, HP, HQ, HR, HS, HT, HU, HV, HW, HX, HY, HZ, IA, IB, IC, ID, IE, IF, IG, IH, II, IJ, IK, IL, IM, IN, IO, IP, IQ, IR, IS, IT, IU, IV, IW, IX, IY, IZ, JA, JB, JC, JD, JE, JF, JG, JH, JI, JJ, JK, JL, JM, JN, JO, JP, JQ, JR, JS, JT, JU, JV, JW, JX, JY, JZ, KA, KB, KC, KD, KE, KF, KG, KH, KI, KJ, KK, KL, KM, KN, KO, KP, KQ, KR, KS, KT, KU, KV, KW, KX, KY, KZ, LA, LB, LC, LD, LE, LF, LG, LH, LI, LJ, LK, LL, LM, LN, LO, LP, LQ, LR, LS, LT, LU, LV, LW, LX, LY, LZ, MA, MB, MC, MD, ME, MF, MG, MH, MI, MJ, MK, ML, MM, MN, MO, MP, MQ, MR, MS, MT, MU, MV, MW, MX, MY, MZ, NA, NB, NC, ND, NE, NF, NG, NH, NI, NJ, NK, NL, NM, NN, NO, NP, NQ, NR, NS, NT, NU, NV, NW, NX, NY, NZ, OA, OB, OC, OD, OE, OF, OG, OH, OI, OJ, OK, OL, OM, ON, OO, OP, OQ, OR, OS, OT, OU, OV, OW, OX, OY, OZ, PA, PB, PC, PD, PE, PF, PG, PH, PI, PJ, PK, PL, PM, PN, PO, PP, PQ, PR, PS, PT, PU, PV, PW, PX, PY, PZ, QA, QB, QC, QD, QE, QF, QG, QH, QI, QJ, QK, QL, QM, QN, QO, QP, QQ, QR, QS, QT, QU, QV, QW, QX, QY, QZ, RA, RB, RC, RD, RE, RF, RG, RH, RI, RJ, RK, RL, RM, RN, RO, RP, RQ, RR, RS, RT, RU, RV, RW, RX, RY, RZ, SA, SB, SC, SD, SE, SF, SG, SH, SI, SJ, SK, SL, SM, SN, SO, SP, SQ, SR, SS, ST, SU, SV, SW, SX, SY, SZ, TA, TB, TC, TD, TE, TF, TG, TH, TI, TJ, TK, TL, TM, TN, TO, TP, TQ, TR, TS, TT, TU, TV, TW, TX, TY, TZ, UA, UB, UC, UD, UE, UF, UG, UH, UI, UJ, UK, UL, UM, UN, UO, UP, UQ, UR, US, UT, UY, UZ, VA, VB, VC, VD, VE, VF, VG, VH, VI, VJ, VK, VL, VM, VN, VO, VP, VQ, VR, VS, VT, VU, VV, VW, VX, VY, VZ, WA, WB, WC, WD, WE, WF, WG, WH, WI, WJ, WK, WL, WM, WN, WO, WP, WQ, WR, WS, WT, WU, WV, WW, WX, WY, WZ, XA, XB, XC, XD, XE, XF, XG, XH, XI, XJ, XK, XL, XM, XN, XO, XP, XQ, XR, XS, XT, XU, XV, XW, XX, XY, XZ, YA, YB, YC, YD, YE, YF, YG, YH, YI, YJ, YK, YL, YM, YN, YO, YP, YQ, YR, YS, YT, YU, YV, YW, YX, YZ, ZA, ZB, ZC, ZD, ZE, ZF, ZG, ZH, ZI, ZJ, ZK, ZL, ZM, ZN, ZO, ZP, ZQ, ZR, ZS, ZT, ZU, ZV, ZW, ZX, ZY, ZZ.		DATE: 5/23/73 SCALE: 1/8" = 1" TOL: FRACT. ± 1/32 XX ± .01 XXX ± .005 < C 1/2"
MOSELEY ASSOCIATES, INC. SANTA BARBARA DESIGN PARK GOLETA, CALIFORNIA 93117	Schematic RPL-3 RECEIVER	
91C6597	GI	

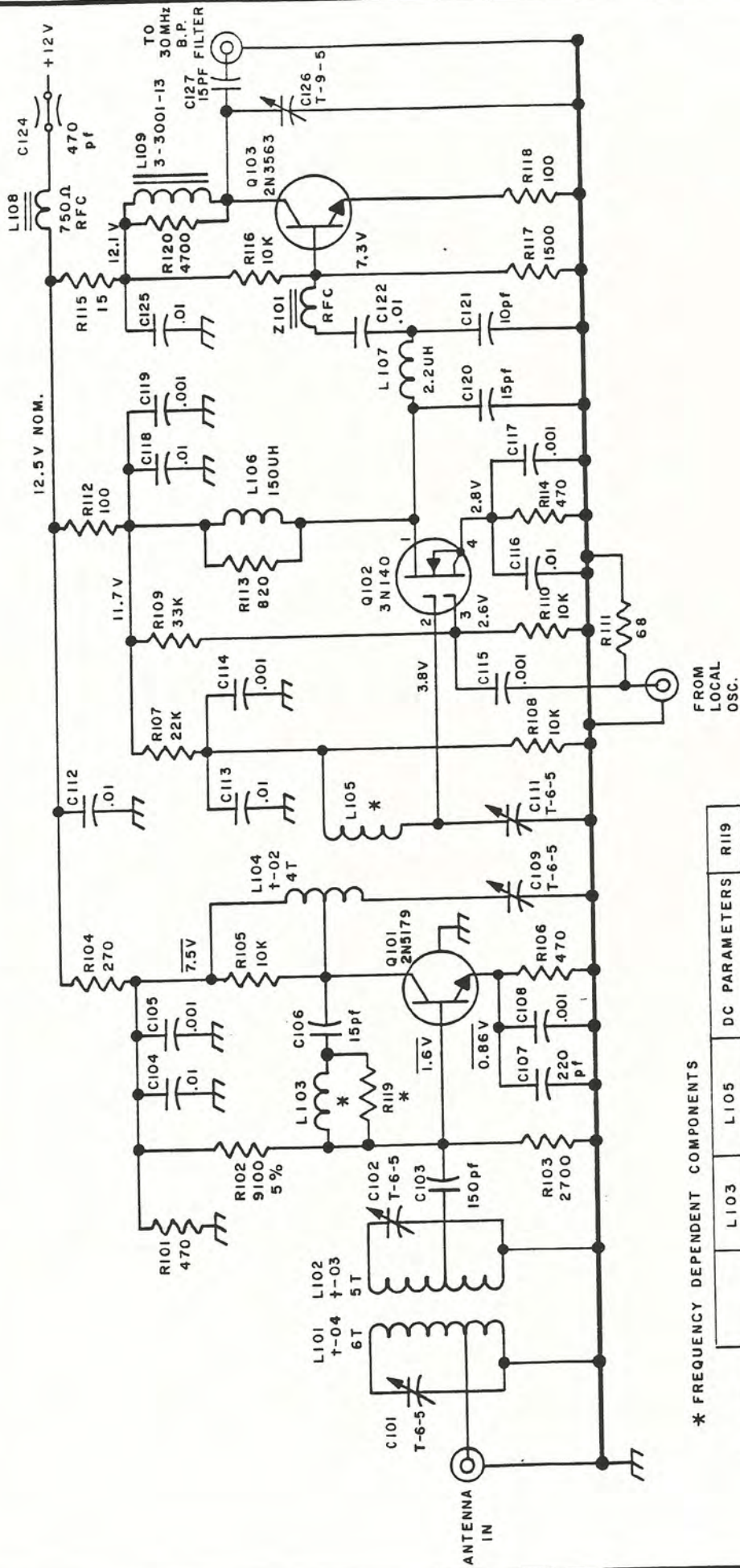

\* FREQUENCY DEPENDENT COMPONENTS

	L103	L105	DC PARAMETERS	R119
160 MHz	1.5UH	MAI 3-2001-02	XXX	1200
220 MHz	.56UH	MAI 3-2001-01	XXX	2200

NOTES:  
 1 UNLESS OTHERWISE SPECIFIED  
 RESISTOR VALUES ARE IN OHMS, 1/4 W, 10%.  
 CAPACITOR VALUES ARE IN MICROFARADS.

- 2 P. C. BOARD 51A5444.
- 3 COMPONENT LAYOUT 20A2351.
- 4 † DENOTES COIL 3-2001

FROM  
 LOCAL  
 OSC.

**MOSELEY ASSOCIATES, INC.**  
 SANTA BARBARA RESEARCH PARK  
 GOLETA, CALIFORNIA 93017

**SCHEMATIC**

**148 - 220 MHz CONVERTER**

TOL: FRACT. ± 1/32, .XX ± .030, .XXX ± .010, < ± 1/2°  
 DWN F X Y 1/24/73 SCALE:  
 CHK ENG

91A 6578 E

REVISIONS		MGMT. APPR.	DATE
A	ADD Z101, ECO 987		2/21/73
B	ECO 652, 11 MAR 74 F.X.Y.		
C	160 MHZ: L103-WAS .82UH DELETE C129, Z101 & C110 VALUE CHANGES ECO 647, 22 APR 74 F.X.Y.		
D	ADD C125-C127, L109 & R119 DELETE C129, Z101 & C110 VALUE (160MHZ) ECO 668 5 JUL 74 F.X.Y.		
E	ADD R120 & Z101, L109 WAS .62UH (160MHZ) ECO 668 5 JUL 74 F.X.Y.		

If You Didn't Get This From My Site,  
 Then It Was Stolen From...

www.SteamPoweredRadio.Com

4-40 X 3/16 B.H.  
4 PLCS

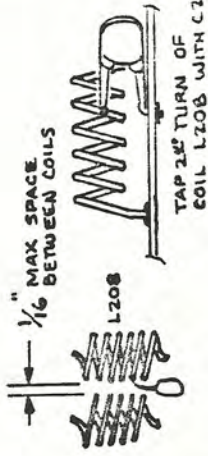
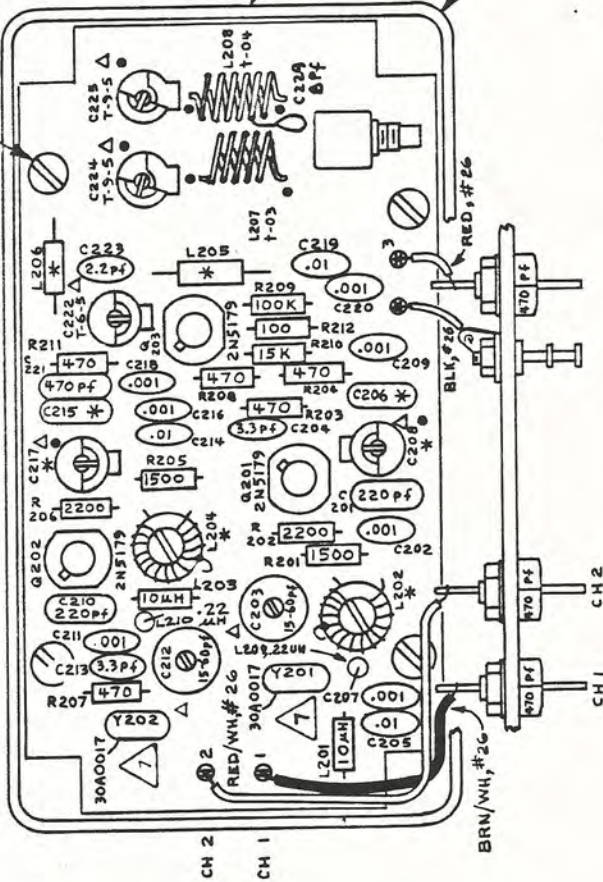

LABEL 20A2352-( )

502066

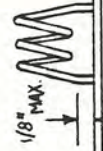

TYPICAL MOUNTING  
L207 & L204

NYLON NUT  
" WASHERS  
" SCREW

\* FREQUENCY DEPENDENT COMPONENTS

	C206	C208	L206
	C215	C217	L205
ITEM 1 (160 MHZ)	24 pf	T-9-5	1.5 UH .47 UH
ITEM 2 (220 MHZ)	10 pf	T-6-5	.82 UH .22 UH

NOTES:

- UNLESS OTHERWISE SPECIFIED  
RESISTOR VALUES ARE IN OHMS, 1/4 W, 10%  
CAPACITOR VALUES ARE IN MICROFARADS.
- P. C. BOARD 51A5445.
- SCHEMATIC 91A6579.
- + - DENOTES COIL 3-2001.
- Δ DENOTES POLARITY.
- DENOTES SOLDER ON TOP SIDE OF BD.
- ▲ INSTALL CRYSTALS (Y201, Y202) IN TEST.

USED ON: RPL-3 RCVR  
ITEM NO: -1 9300641  
ITEM NO: -2 9300658

**MOBELEY ASSOCIATES**  
SANTA BARBARA RESEARCH LAB  
GOLETA, CALIFORNIA 93141

**COMPONENT LAYOUT**  
RCVR 2 CHANNEL LOCAL OSC.

TOL: FRACT. ± 1/32, .XX ± .030, .XXX ± .010, .XXX ± 1/32

DWN FXY 5/31/73 SCALE: FULL

CHK ENG

MGMT. APPR. DATE

REVISIONS

1	ADD WIRE COLORS.	18/APR/74 REB
2	ARTWORK REVISION B.	13/MAR/74 REB.
3	CHANGE POSITION L209 & L210.	1/23/74 REB.
4	ADD L209, L210, & C229.	
5	REDRW. ENCLOSURE 5B-1.	6/18/73

20A2352



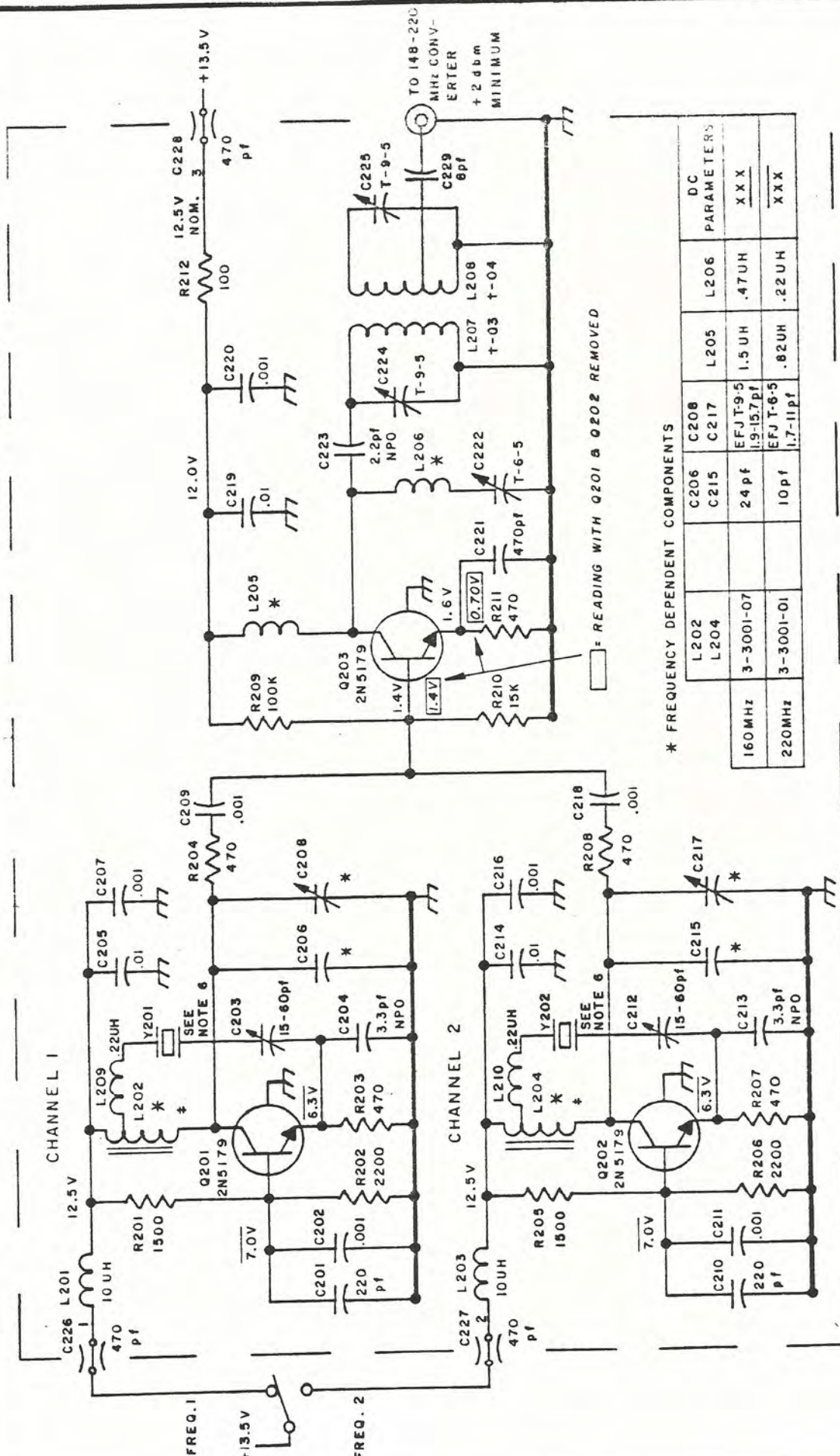

\* FREQUENCY DEPENDENT COMPONENTS

	L202 L204	C206 C215	C208 C217	L205 L206	L206 L207	DC PARAMETERS
160MHZ	3-3001-07	24 pf	EFJT-9-5 1.9-15.7 pf	1.5 UH	.47UH	XXX
220MHZ	3-3001-01	10 pf	EFJ T-6-5 1.7-11 pf	.82UH	.22 UH	XXX

NOTES:

- UNLESS OTHERWISE SPECIFIED RESISTOR VALUES ARE IN OHMS, 1/4W, 10%. CAPACITOR VALUES ARE IN MICROFARADS.
- P. C. BOARD 51A5445.
- COMPONENT LAYOUT 20A2352.
- 1 DENOTES COIL 3-2001
- 4 DENOTES TOROID 3-3001
- 6 Y201, Y202 =  $\frac{Fc-30,000}{Mhz}$

**MOSELEY ASSOCIATES, INC.**  
 SANTA BARBARA RESEARCH PARK  
 GOLETA, CALIFORNIA 93017

**SCHEMATIC**  
 2 CHAN. L.O. RCVR

TOL: FRACT. ± 1/32, .XX ± .038, .XXX ± .048  
 DWN F X Y 1/23/73 SCALE: 1:1  
 CHK RNS 91A6579 D

REVISIONS  
 DATE REVISIONS  
 Δ ADD \* FOR L202 & L204 3/23/73  
 M RCD L209, L210, & C229 1/23/74 RB.  
 O RCD T14, 20 PER 75 F X Y  
 P RCD 1, 2 & 3 WERE 2N4259  
 RCD 76 & C207 L.I.  
 R201 & R205 VALUES WERE IN CHART

If You Didn't Get This From My Site,  
 Then It Was Stolen From...  
[www.SteamPoweredRadio.Com](http://www.SteamPoweredRadio.Com)

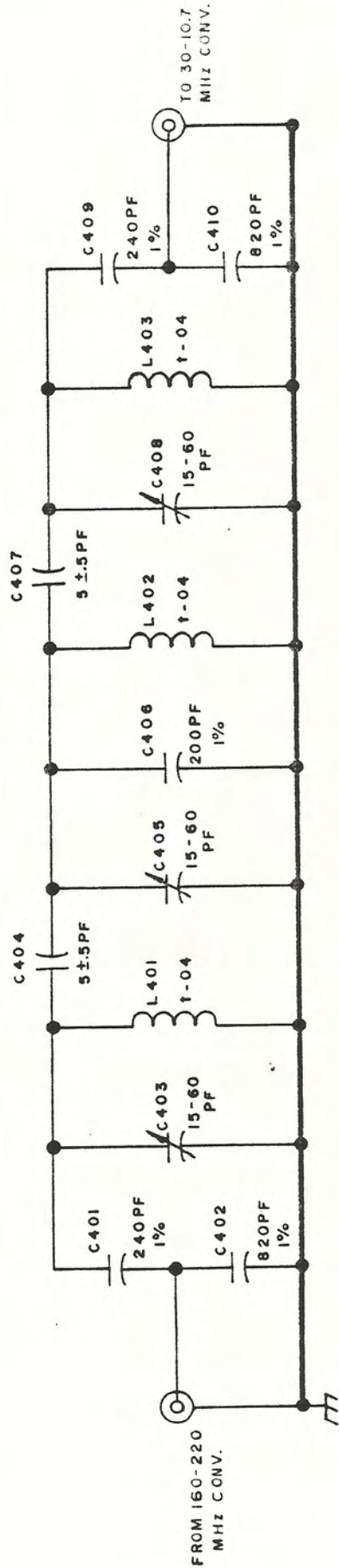

NOTES:

- 1 1-DENOTES DRW 3-3001
- 2 P.C. BOARD 51A 5451
- 3 COMPONENT LAYOUT 20A 2553

USED ON  
 RPL-3 RCVR  
 PCL-101 RCVR 150/220MHz OPTION

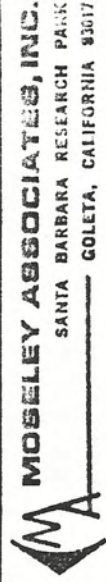

**MOSELEY ASSOCIATES, INC.**  
 SANTA BARBARA RESEARCH PARK  
 COLETA, CALIFORNIA 93017

**SCHEMATIC**

**30 MHz BANDPASS FILTER**

TOL: FRACT. ± 1/32, .XX ± .030, .XXX ± .012	SCALE:
DWN <i>1-26-73</i>	SCALE:
CHK FXY <i>1/30/73</i>	SCALE:
ENG <i>1/24/73</i>	SCALE:
<b>91A6580</b>	
<b>A</b>	

AD OPTION TO PCL-101 ECO	DATE
766	1 NOV 75
FXY	
MGMT. APPR.	
REVISIONS	
DATE	

If You Didn't Get This From My Site,  
 Then It Was Stolen From...  
[www.SteamPoweredRadio.Com](http://www.SteamPoweredRadio.Com)

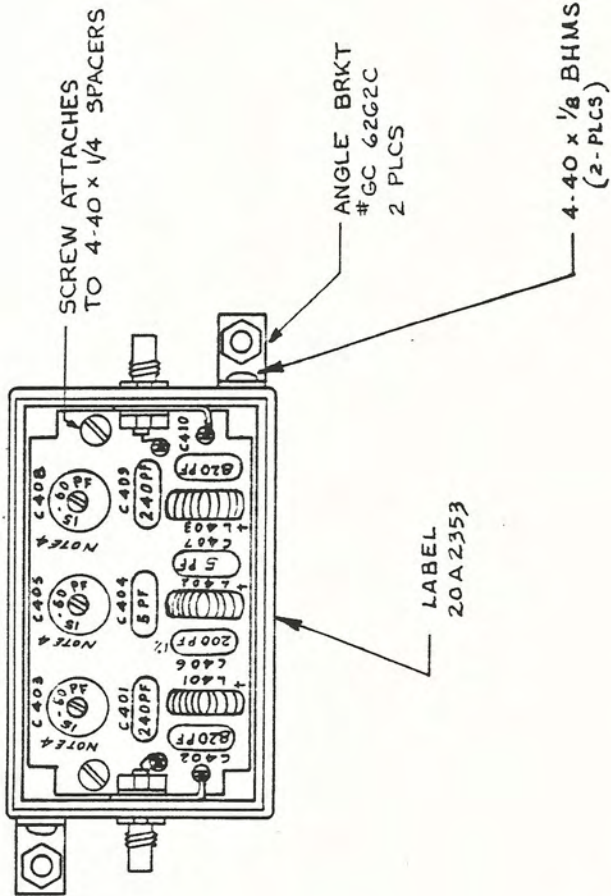

- NOTES:
- 1 P. C. BOARD SIA 5451
  - 2 †- DENOTES DRW 3-3001-04
  - 3 SCHEMATIC 91A 6580
  - 4 C403, C405 †C408: ROTOR (†) TO GND

USED ON  
 RPL-3 RCVR  
 PCL-101 RCVR 150/220MHZ OPTION

**MOBELEY ASSOCIATES, INC.**  
 SANTA BARBARA RESEARCH PARK  
 GOLETA, CALIFORNIA 93117

**COMPONENT LAYOUT  
 BANDPASS FILTER**

TOL: FRACT. ± 1/32, .XX ± .030, .XXX ± .010	SCALE: FULL
DWN 1-29-73	CHK 1/30/73
ENG 3/1/73	

20A2353 D

MGMT. APPR.	DATE
REVISIONS	
A ADD BOX ASSY. 10/18/73 RES	
B ADD SCREW CALC-OUT 2-25-74 JMM	
C ADD OPTION TO PCL-101 E0766 6 NOV 75 FXY	
D ADD LABEL 21 NOV 75 FXY	

If You Didn't Get This From My Site,  
 Then It Was Stolen From...  
[www.SteamPoweredRadio.Com](http://www.SteamPoweredRadio.Com)

INSTALL SWAGED TERMINAL POSTS. USECO 2520 B-4.5  
 3/8" ACETAPE (1560135) ON SIDES OF CAN  
 TAPE SHOULD BE AT BOTTOM OF CAN. (T1&L1)

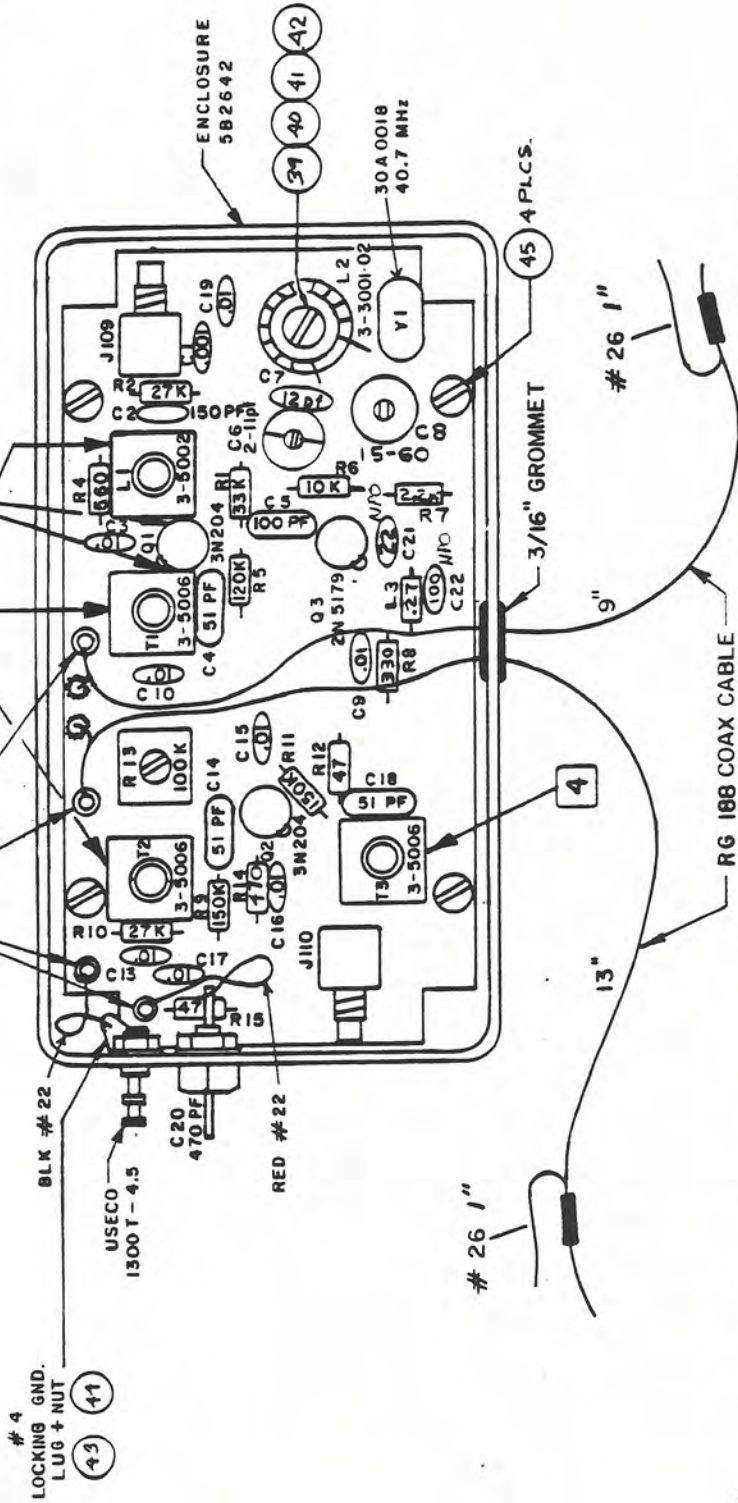

NOTES

1. UNLESS OTHERWISE SPECIFIED RESISTOR VALUES ARE IN OHMS, 1/4 W, 10%. CAPACITORS ARE IN MICROFARADS.
2. P.C. BOARD 51A5869-13,-23
3. SCHEMATIC 91B7139

4 REMOVE THE 8/32 SCREWS FROM T1,T2,T3 & L1 AFTER THEY HAVE BEEN SOLDERED IN PLACE AND INSTALL THE SAME COLOR THREADED CORE AS APPEARS ON TOP OF THE CIP AS SEEN THRU THE TOP OF THE CAN.  
 5. SEE SHEET 2.

ITEM NO: 9300864

SHEET: 1 OF 2

MOSELEY ASSOCIATES, INC. SANTA BARBARA RESEARCH PARK GOLETA, CALIFORNIA 93017	
COMPONENT LAYOUT 30-10.7 MHz CONVERTER RCVR	
TOL: FRACT. ± 1/32, .XX ± .03, .XXX ± .010, ± 1/2"	SCALE:
DWN BWF 22 DEC 78	CHK PAC 19 JAN 79
ENG	20A2734 J.
MEMT APPR.	
DATE	REVISIONS
	2 FEB 79 F.X.Y.
	RELEASED:
	CHANGE PCB ECD 109
	22 JUN 79 ECD 123 A.L.B.
	CHANGE RI AND O4 ALSO
	REMOVE JE AND L3
	51A5869-21
	ADDED OVER 77
	POST 1 ADDD
	POST 1488 12DEC79 DTW
	E1
	SEE ECO NO. 1520
	PCO/605 4-19-80
	DELETED NOTES 445
	F2
	REV PER PCO 1707
	F3
	REV PER PCO 1795
	3 JULY 80 PCO 1795
	F4
	27 MAY 81 ECD 306 A.L.B.
	C6 WITH 2-11PF ADDCT 25
	C16, R4 TO 500Ω REPLACE
	ADJACENT Q1
	ADD TAPE TO T1 & L1 TO
	ADJACENT Q1
	CORRECT DRAWING
	ERRORS ON PARTS LIST
	ECO 278 4 MAY 83
	FIG. 7 HDB-5HT2
	670 4029 9-29-83
	NOTE 5-4460D - 022
	1-2003-RM WAS 270

If You Didn't Get This From My Site,  
 Then It Was Stolen From...  
[www.SteamPoweredRadio.Com](http://www.SteamPoweredRadio.Com)

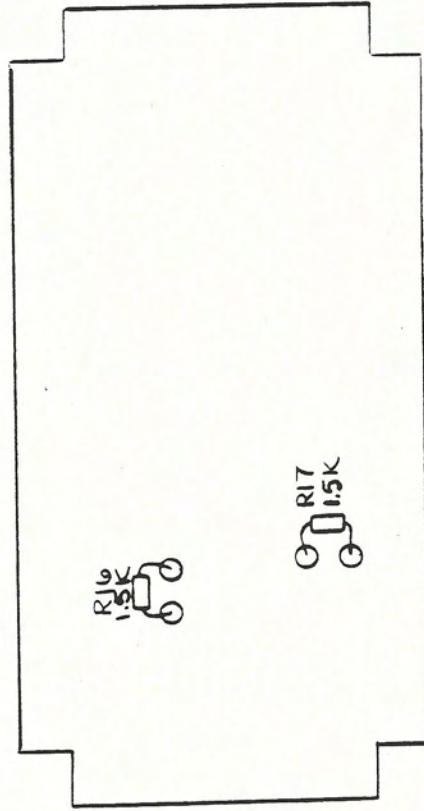

CIRCUIT SIDE

NOTE:

5. RESISTOR LEADS TO BE SHORT  
AS POSSIBLE ON R16, 17.

SHEET: 2 OF 2

DATE		REVISIONS	
MOSELEY ASSOCIATES, INC. SANTA BARBARA RESEARCH PARK SOLITA CALIFORNIA 93117		COMPONENT LAYOUT 30 10.7 MHZ CONVERTER RCVIC	
TOL. PRACT. ± 1/2%	.XX ± .05	.XXX ± .010	< ± 1/2"
DWN	MAF	929-83	SCALE:
CHK	JCP	20-4-83	
ENG			
PART. APP.			20A2734
			J

If You Didn't Get This From My Site,  
Then It Was Stolen From...  
[www.SteamPoweredRadio.Com](http://www.SteamPoweredRadio.Com)

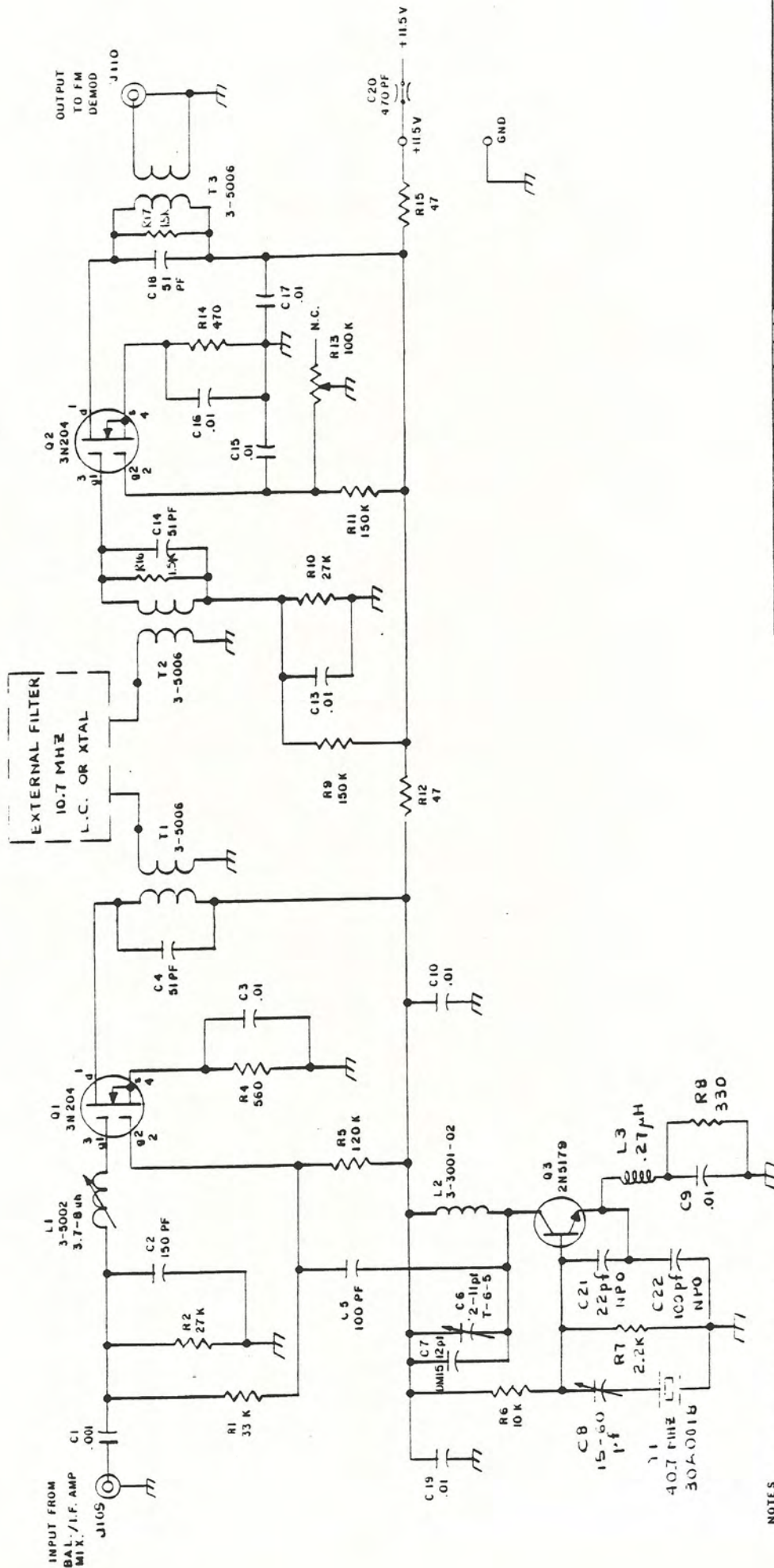

MOBELEY ASSOCIATES, INC.		SANTA BARBARA RESEARCH PARK		SANTA BARBARA, CALIFORNIA 93101	
SCHEMATIC					
30-10.7 MHZ CONVERTER					
TOL: FRACT	1/32	SK 2	DR	XXX	DR
OWN	ONE	SCALE	1/2"	DATE	2/17/73
CHK	ONE	91B7139	1	G	
REVISIONS					
DATE	2 FEB 73	BY	XXX	REASON	
1	2 FEB 73	XXX		REDESIGNED FOR BOARD	
2	2 FEB 73	XXX		CHANGED TO 3N204	
3	2 FEB 73	XXX		CHANGED TO 3N204	
4	2 FEB 73	XXX		CHANGED TO 3N204	
5	2 FEB 73	XXX		CHANGED TO 3N204	
6	2 FEB 73	XXX		CHANGED TO 3N204	
7	2 FEB 73	XXX		CHANGED TO 3N204	
8	2 FEB 73	XXX		CHANGED TO 3N204	
9	2 FEB 73	XXX		CHANGED TO 3N204	
10	2 FEB 73	XXX		CHANGED TO 3N204	
11	2 FEB 73	XXX		CHANGED TO 3N204	
12	2 FEB 73	XXX		CHANGED TO 3N204	
13	2 FEB 73	XXX		CHANGED TO 3N204	
14	2 FEB 73	XXX		CHANGED TO 3N204	
15	2 FEB 73	XXX		CHANGED TO 3N204	
16	2 FEB 73	XXX		CHANGED TO 3N204	
17	2 FEB 73	XXX		CHANGED TO 3N204	
18	2 FEB 73	XXX		CHANGED TO 3N204	
19	2 FEB 73	XXX		CHANGED TO 3N204	
20	2 FEB 73	XXX		CHANGED TO 3N204	
21	2 FEB 73	XXX		CHANGED TO 3N204	
22	2 FEB 73	XXX		CHANGED TO 3N204	
23	2 FEB 73	XXX		CHANGED TO 3N204	
24	2 FEB 73	XXX		CHANGED TO 3N204	
25	2 FEB 73	XXX		CHANGED TO 3N204	
26	2 FEB 73	XXX		CHANGED TO 3N204	
27	2 FEB 73	XXX		CHANGED TO 3N204	
28	2 FEB 73	XXX		CHANGED TO 3N204	
29	2 FEB 73	XXX		CHANGED TO 3N204	
30	2 FEB 73	XXX		CHANGED TO 3N204	

NOTES

- UNLESS OTHERWISE SPECIFIED RESISTORS ARE IN OHMS, 1/4 W, 10% CAPACITORS ARE IN MICROFARADS.
- P.C. BOARD 51A5869
- COMPONENT LAYOUT 20A 2734

If You Didn't Get This From My Site,  
Then It Was Stolen From...  
[www.SteamPoweredRadio.Com](http://www.SteamPoweredRadio.Com)

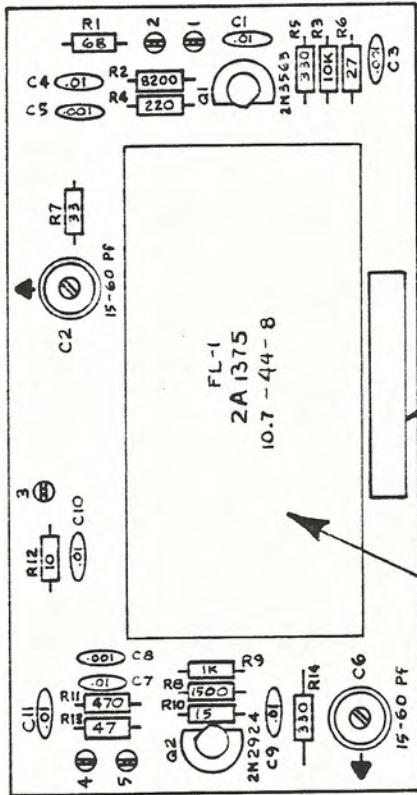

SEE NOTE 4. LABEL 20A2365.

NOTES:

1. UNLESS OTHERWISE SPECIFIED RESISTOR VALUES ARE IN OHMS, 1/4 W, 10% CAPACITOR VALUES ARE IN MICROFARADS.
2. P.C. BOARD 51A5477
3. SCHEMATIC 91A6593
4. DO NOT CUT LEADS ON FILTER AFTER SOLDERING. USE INTERNAL TOOTH WASHER AND NUT TO MOUNT FILTER. #4-40

If You Didn't Get This From My Site,  
Then It Was Stolen From...  
[www.SteamPoweredRadio.Com](http://www.SteamPoweredRadio.Com)

1	ADD NOTE 4 PCO 2033 12MAR81 CAH
0	RODED LABEL 17MARCH 78 L.I.
0	ARTWORK REV. B FL-1 WAS 54870 KF 6/24/75
B	CHANGE VALUES R2 & R2 ECO 630.1/23/74 REP.
A	BOARD REVERSED RFB 9-26-73
REVISIONS	
DATE	
MGMT. APPR.	

**MOSELEY ASSOCIATES, INC.**  
SANTA BARBARA RESEARCH PARK  
GOLETA, CALIFORNIA 93017

**COMPONENT LAYOUT**  
**XTAL FILTER INTERFACE, RPL-3**

TOL: FRACT. ± 1/32, .XX ± .030, .XXX ± .010, < ± 1/2°	SCALE: FULL
DWN REB 9-24-73	ENG 5/27/73
CHK FXY 5/27/73	20A2365
ENG 5/27/73	D1

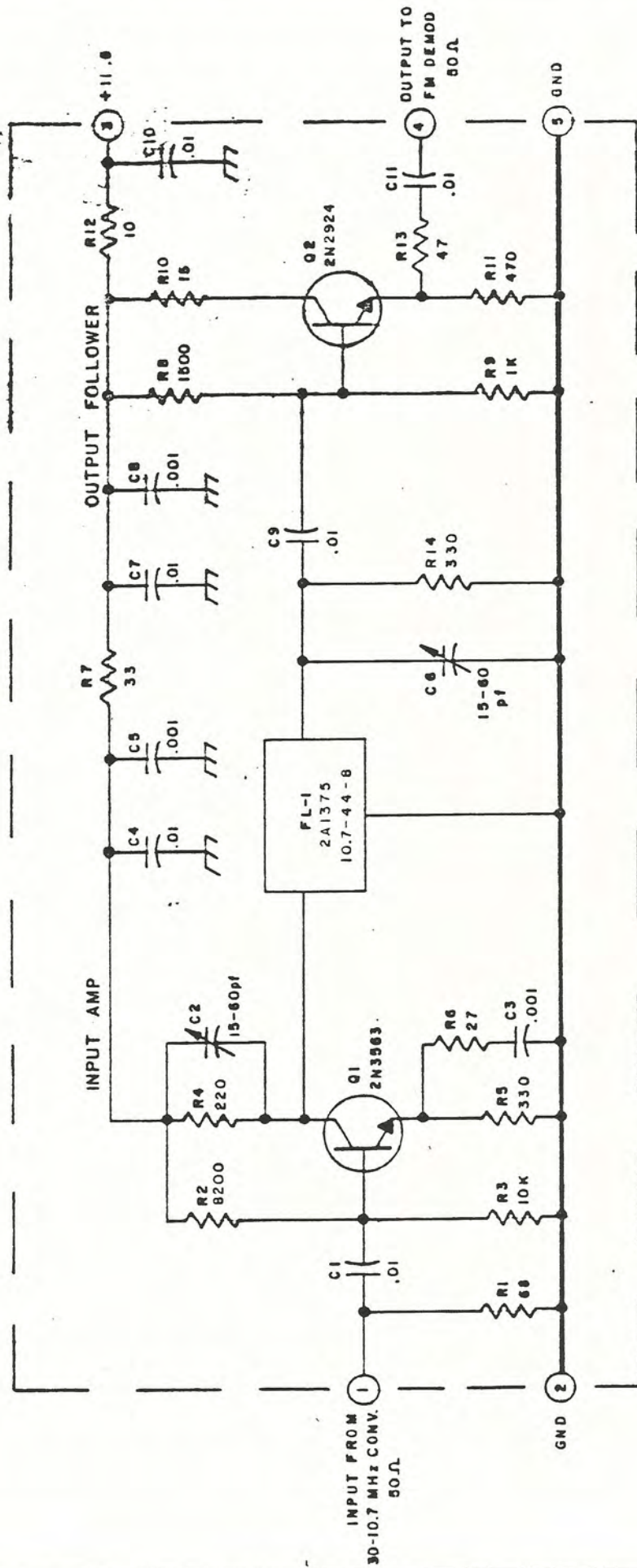

NOTES:

- 1 UNLESS OTHERWISE SPECIFIED  
RESISTOR VALUES ARE IN OHMS, 1/4W, 10%.  
CAPACITOR VALUES ARE IN MICROFARADS.

2 P.C. BOARD 61A5477.

3 COMPONENT LAYOUT 20A2365.

USED ON

RPL-3 HOUR



**MOXLEY ASSOCIATES, INC.**  
SANTA BARBARA RESEARCH PARK  
GOLTA, CALIFORNIA 93027

**SCHEMATIC**

**XTAL FILTER INTERFACE**

TOL. FRACT. ±.1/72, .XX ±.5/2, .XXX ±.1/10  
DWN PXY 10/25/73 SCALE: 1/8  
CHK  
ENJ

REV.	DATE	REVISIONS	REMT. APPR.
1		CHANGE VALUES R2 & C2 EDC 630 1/25/74 RER	
2		FL1 WAS A4B70 F.X.V.	

If You Didn't Get This From My Site,  
Then It Was Stolen From...  
[www.SteamPoweredRadio.Com](http://www.SteamPoweredRadio.Com)

91A 6593 B



ASSEMBLY DETAIL OF CR804 & CR805,  
AND CR809 & CR810.

INSTALL SHRINK TUBING OVER EACH  
DIODE PAIR.

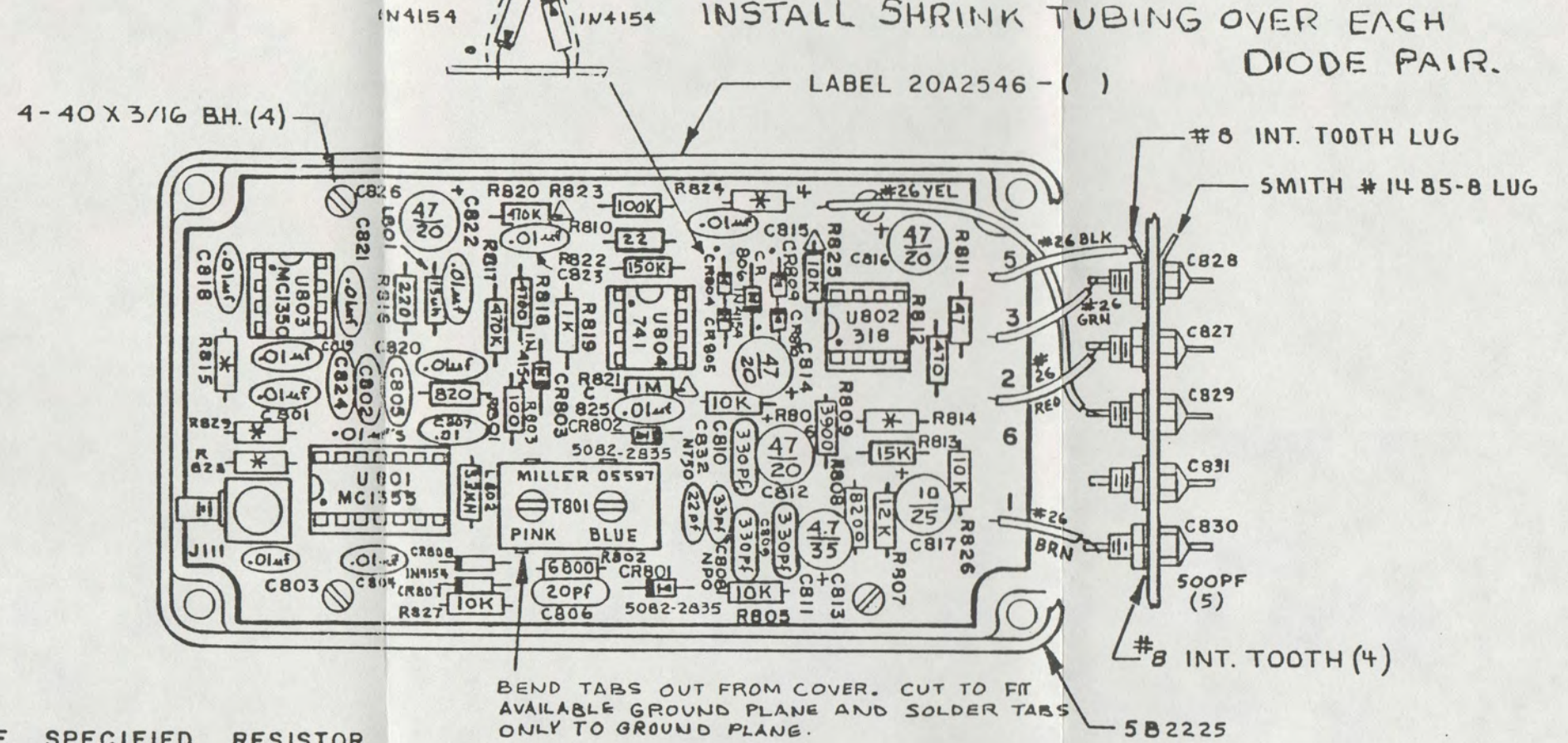

NOTES:

1. UNLESS OTHERWISE SPECIFIED RESISTOR VALUES ARE IN OHMS 1/4W, 10%, CAPACITOR VALUES ARE IN MICROFARADS.
2. P.C. BOARD 51A5681.
3. SCHEMATIC 91B6847.
4.  $\Delta$  SOLDER RESISTOR LEADS ON BOTH SIDES OF P.C. BOARD

5. \* = PARTS DEPENDENT ON DEVIATION — VALUES FOLLOW:

	R815	R828	R829	R814	R824	DEV	STOCK NO.:
ITEM 1	47	DELETE	JUMPER W/TEFLON	680K	1500	5KHZ	9300708
ITEM 2	27	56	680	470K	1500	12KHZ	9300716
ITEM 3	27	56	680	470K	JUMPER W/TEFLON	12KHZ	9301193

ITEM 3 FOR USE WITH  
74 MHz I. F.

REVISE NOTE ON TABS OF T801. ECO 3791 25 FEB 85 CH		ADD CR809 & CR810 R823 WAS 47K ECO 3131 20 OCT 81 CAH		ADD NOTE FOR ITEM 3 PCD 3022 5-24-81 A.J.B.		ADDED ITEM 3 TO TABLE ECO 1810 LDH 14 JUL 80		U802, 804, 801, 803 REMOVED IC. 15 JUN 80 EDDT154 A.J.B.		J1111 WAS 1901 PER PCO 1708 LDH 1 MAY 80		CR817 WAS 47K. ECO 10 MAY 79 BWF		CHECKED: Show CR804, CR805 R8 500 78 and 960 A.J.B.		REMOVE CR801 & CR808 TO 5 HEIGHT REF. Y.T. 870 960 7 AUG. 78		L802 WAS 100K. CR801 & 2 WERE INGW.F. ECO 5144. 50 UNT 8 P.X.Y.		CR801 & CR802 HEIGHT WAS 3/16" 30 DEC 77 F.X.Y.		T801 WAS 8043 EFFECTIVE WITH ECO 912. 19 DEC 77 F.X.Y.		R805 & 84 WERE 700. R824 WAS 47K R817 WAS 100K. R825 WAS 47K R817 WAS 100K. DEC 77 P.X.Y.		ADD R824, R825 & CR808 & CR809 PER ECO 808. 18 MAY 78 F.X.Y.		ADD CR807, CR808, R827, L802 & CR828, CR808 & R814, CR809 ADDED TO TABLE. 15 JUN 80 EDDT154		R812 WAS 100K. 9-24-75 G-M		DATE MGMT. APPR.		REVISIONS		DATE	
N		M2		L2		L1		KI		JI		J		I		H		G		F		E		D		C		B		A		G-M		DATE			
TOL: FRACT. ± 1/32, .XX ± .030, .XXX ± .010, < ± 1/2°		DWN G-M		B-29-75		SCALE: FULL		CHK FXY		11 SEP. 75		20A2546		N		ENG		9-15-5																			



COMPONENT LAYOUT  
RCVR FM DEMOD & MTR AMP

- NOTES:
1. UNLESS OTHERWISE SPECIFIED RESISTOR VALUES ARE IN OHMS, 1/4W, 10%. CAPACITOR VALUES ARE IN MICROFARADS.
  2. P.C. BOARD 51A5681
  3. COMPONENT LAYOUT 20A2546.
  4. P.C. BOARD SHOWN IN DASHED LINES.
  5. NS DENOTES NO SIGNAL
  6. NS DENOTES MAX. SIGNAL

\* PARTS DEPENDENT ON DEVIATION

ITEM 1	R815	R828	R829	R814	R824	DEV
47	DELETE	JUMPER	680K	1500	5KHZ	
ITEM 2	27	56	680	470K	12KHZ	
ITEM 3	27	56	680	470K	12KHZ	

FOR USE WITH 74 MHz I.F.

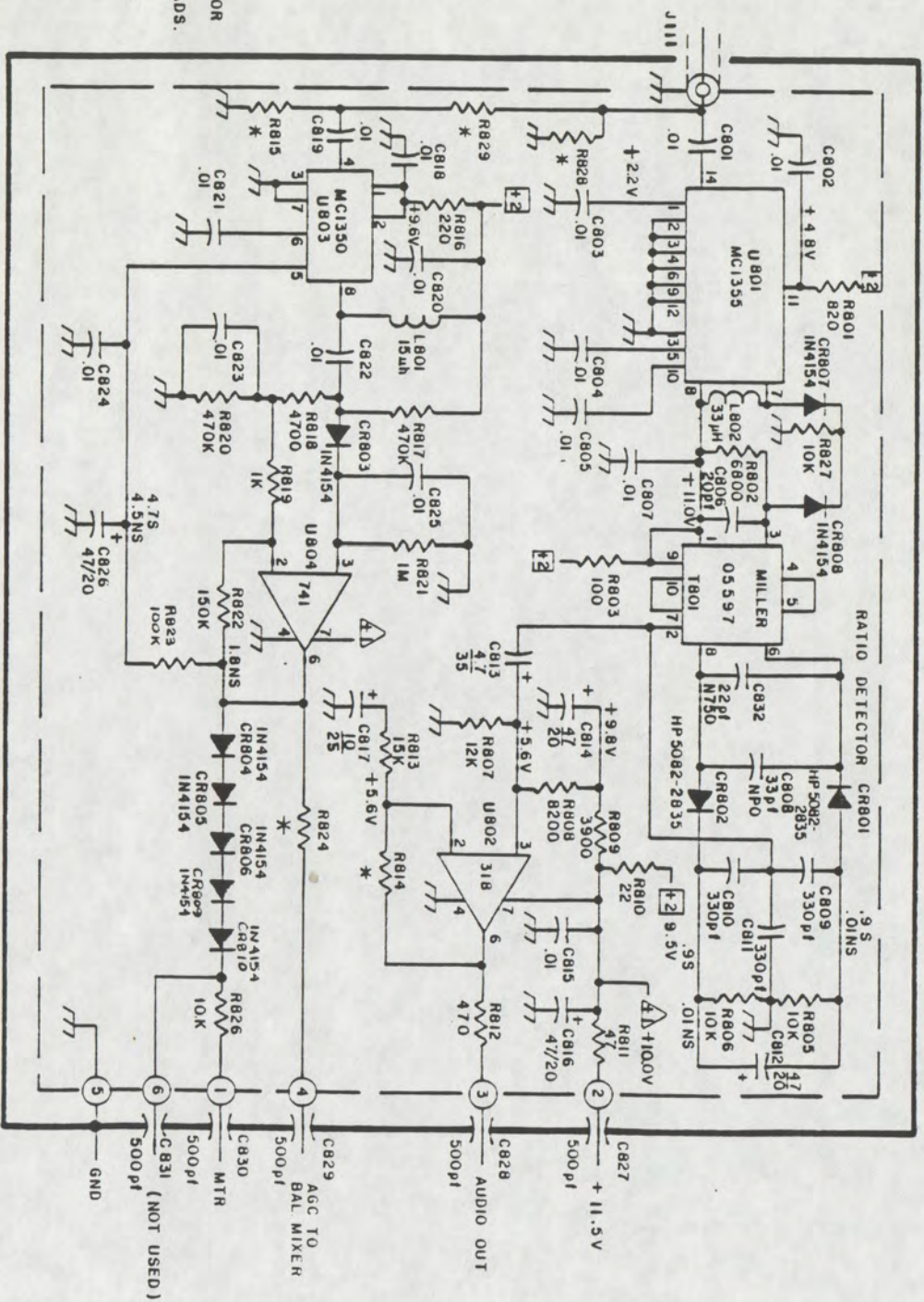

www.SteamPoweredRadio.Com

K2	ADD CR809 AND CR810 R823 WAS 47K ECC03187 20CT81 CAP
J2	ADD. NOTE TO ITEM 3 PCD 3032 5-24-81 A.B.
J1	ADDED ITEM 3 TO CHART ECC03187 LDM 14 JUL 80
11	U803, 801, 802, 804 REDESIGNED IC. 5 JUN 80 ECC 1789 A.B.
10	U801 WAS "J801" 11-11-79 2.2V WAS 2.2V PER 1705 LDM 1 MAY 80
9	C817 WAS 47 NF. ECC 1044. 12 FEB. 79 BWF
8	L802 WAS 10uH. CR808 & 2 WERE 1N644. ECC 0848. 5 JUN 78 F.X.Y.
7	T801 WAS 8849. EFFECTIVE. MPM ECC 912. 18 DEC 77 F.X.Y.
6	U805 & WERE 880. R826 WAS 47K. R804 WAS 1M. ECC 111. 13 DEC 77 F.X.Y.
5	ADD R824, R823, R829, CR829 & CR830 PER ECC 801. 18 MAY 78 F.X.Y.
4	ADD CR07, CR08, R827, L802, C832. CHG. CR08 WAS R804 & R814 WAS R803 PER E.C.C. 779. 12-17-78 GM
3	R812 WAS 100K 9-24-75 CM
REVISIONS DATE	
Mgmt. Appr.	
<b>MOBELEY ASSOCIATES, INC.</b> SANTA BARBARA RESEARCH PARK COLETA, CALIFORNIA 93117	
<b>SCHEMATIC</b> RCVR FM DEMOD 8 MTR AMP	
TOL: FRACT ± 1/2%	AX ± .001
DWN G-TM	B-2B-75
CHK FXY	SCALE NONE
ENG	11 SEP 75
9	6847
K2	

NOTES CONT.:  
 9. WITH OPTIONAL SQUELCH  
 RELAY, BD. IS  
 20A2367-( ) S

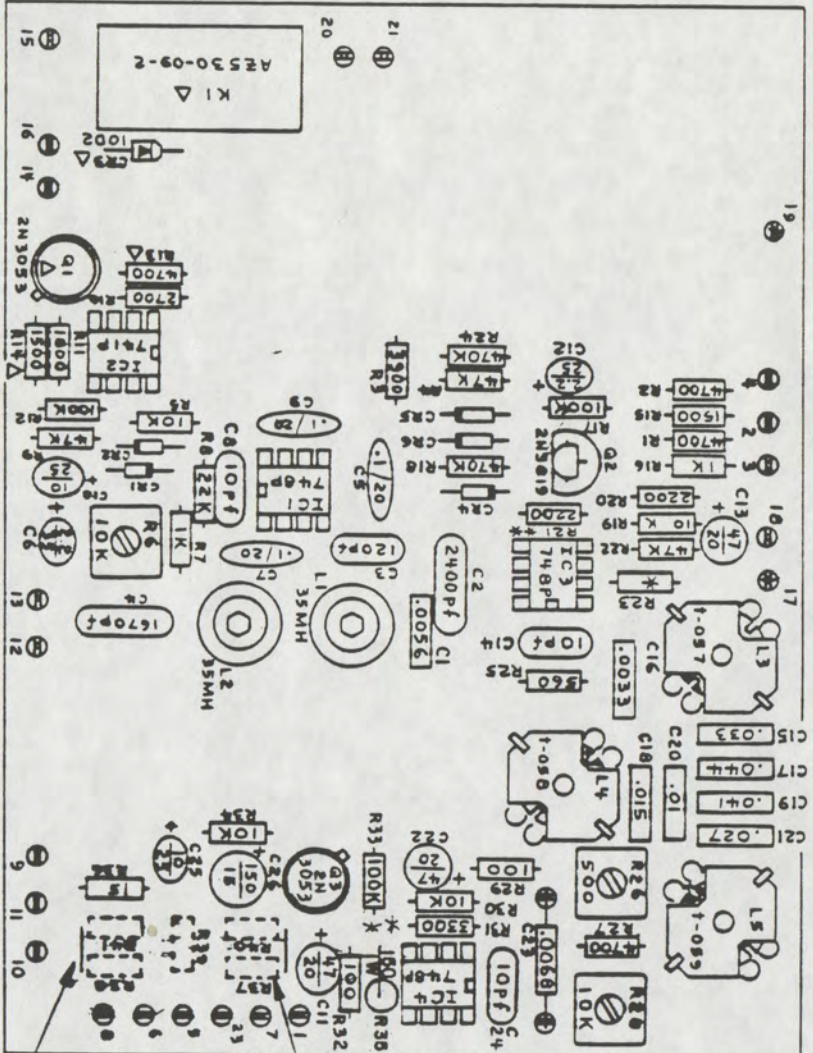

\* FREQUENCY DEPENDENT PART  
 R23  
 ITEM 1 RPL-3 330K  
 ITEM 3 RPL-4 220K

R37 THROUGH R41  
 OPTIONAL RESISTORS  
 JUMPER 2 PLACES IF OPTIONAL  
 RESISTORS NOT USED

NOTES:

- 1 UNLESS OTHERWISE SPECIFIED RESISTOR VALUES ARE IN OHMS, 1/4 W, 10% CAPACITOR VALUES ARE IN MICROFARADS.
- 2 P. C. BOARD 51A5848
- 3 SCHEMATIC 91C6595.
- 4  $\square$  DENOTES IN4154 DIODE.
- 5 \* DENOTES SELECTED VALUE.
- 6 † DENOTES CUP CORE COIL 2C1400.
- 7 REMOVE C23 TO REMOVE DEEMPHASIS.
- 8 OPTIONAL SQUELCH RELAY PARTS.

REV	DESCRIPTION	DATE
36-3-15-1	AUDIO PROCESSOR RCVR MAT20A2367-1	11/27/74
36-3-15-1	AUDIO PROCESSOR RCVR MAT20A2367-3S	9204090
36-3-15-1	AUDIO PROCESSOR RCVR MAT20A2367-1	9202094
36-3-15-1	AUDIO PROCESSOR RCVR MAT20A2367-1	9204082
36-3-15-1	AUDIO PROCESSOR RCVR MAT20A2367-1	9202086

CHANGE STOCK CHART  
 ADD STOCK NOS.  
 Z22 + MAY 82  
 Z21 + MAY 82

P.C. BOARD WAS 51A5848  
 31 OCT 78 FXY

REI WAS 1500. ECO 974.  
 24 OCT 78 BWF

REI WAS 1/4 R33 CHANGE  
 ECO 504 24 FEB 72 B.T.  
 DELETE ITEM 2

REI WAS 1502. R39 WAS 3902.  
 ECO 767 10 NOV 75 F. Y. Y.

CHANGE VALUES R15, ITEM  
 24-B. ECO 634

REI WAS 1500 JMA  
 ADD NOTE "USED ON" 12-7-73

CIE WAS 10/25, ECO 613  
 10/14/73 REB

ADD NOTE FOR JUMPER  
 WIRE 8/24/78

REVISIONS DATE

MGMT. APPR.

**MOBILITY ASSOCIATES, INC.**  
 SANTA BARBARA RESEARCH PARK  
 SOLISTA, CALIFORNIA 93117

**COMPONENT LAYOUT**  
 AUDIO PROCESSOR RCVR

TOLL FRACT. ± 1/2% JX ± .004  
 DWN FXY 5/7/73 SCALE: FULL  
 CHK SCM XQ UN-C-12

20A2367 HI

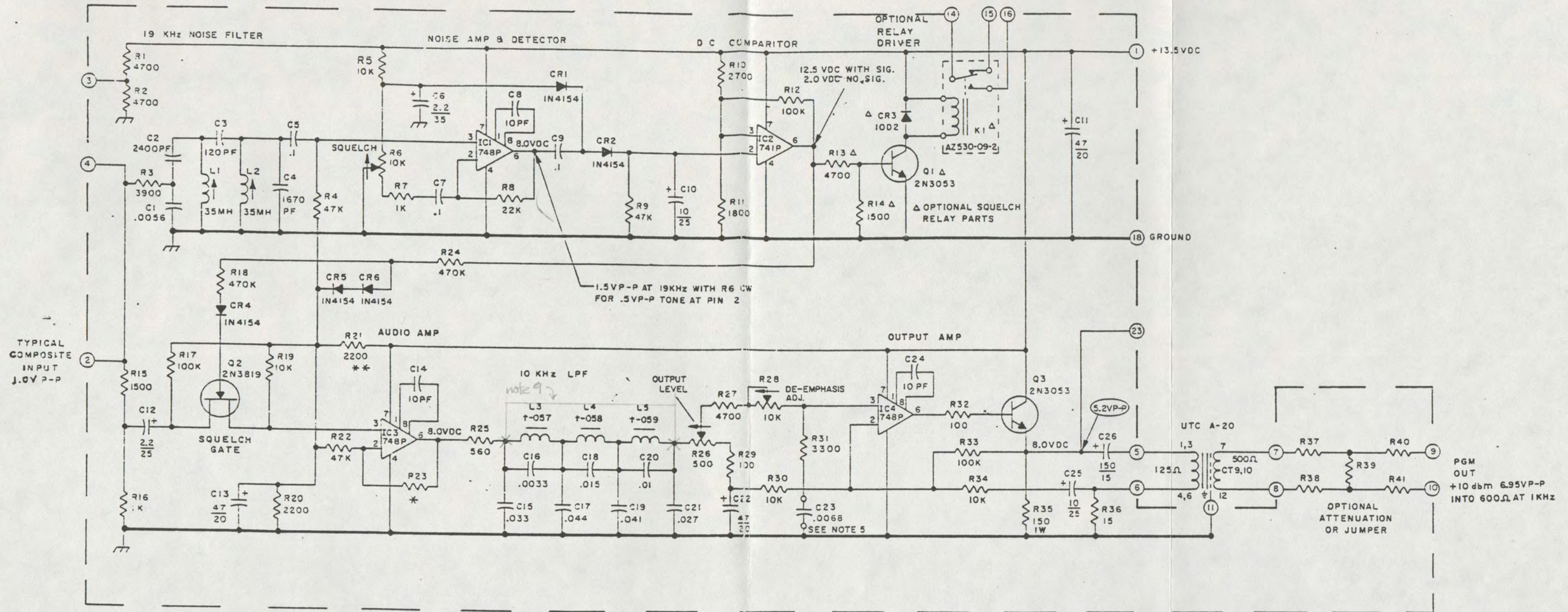

NOTES:

- 1 UNLESS OTHERWISE SPECIFIED RESISTOR VALUES ARE IN OHMS, 1/4W, 10% CAPACITOR VALUES ARE IN MICROFARADS. IC'S LISTED AS 741 (E.G.) ARE SN72741P.
- 2 P.C. BOARD 51A5848.
- 3 COMPONENT LAYOUT 20A2367.
- 4 \*\*DENOTES SELECTED VALUE.
- 5 REMOVE C23 TO REMOVE DEEMPHASIS.
- 6 † DENOTES CUP CORE COIL 2C1400.
- 7 FOR PGM. OUTPUT .86VP-P IS REQUIRED AT PIN 2.
- 8 ○ READINGS AT 1KHZ

9 10kHz low pass filter bypassed for 15kHz audio response.

\* FREQUENCY DEPENDENT PART

ITEM	FREQUENCY RANGE	RESISTOR VALUE
ITEM 1	148-174 MHz	330K
ITEM 2	215-230 MHz	330K
ITEM 3	450-470 MHz	220K

If You Didn't Get This From My Site,  
Then It Was Stolen From...  
www.SteamPoweredRadio.Com

PC BOARD NO WAS 51A1775 18 DEC78 F.X.Y		R21 WAS 1500. ECO 14V. 24 DEC 78 BWP	
R25 WAS 1/4W R33 CHANGES VEO 166 24 FEB 77 B.F.		R26 WAS 100K R29 WAS 330K	
L3 L4 L5 1/2 INCHES F.X.Y		CHANGE VALUES R15, R16 R17 10K R18 10K	
R31 WAS 1500 JHM		ADD NOTE "USED ON" 1817	
C12 WAS 10/25. ECO 619. 10/17/75 RB		DATE	
REVISIONS		MGMT. APPR.	
<b>MOSELEY ASSOCIATES, INC.</b> SANTA BARBARA RESEARCH PARK SOLETA, CALIFORNIA 90777			
<b>SCHEMATIC</b> AUDIO PROCESSOR RCVR			
TOL: FRACT. = 1/22. XX = .2X. .XXX = .01X. <= 1/2"			
DWN FXY 5/7/73 SCALE:			
CHK			
ENG		91C 6595	G

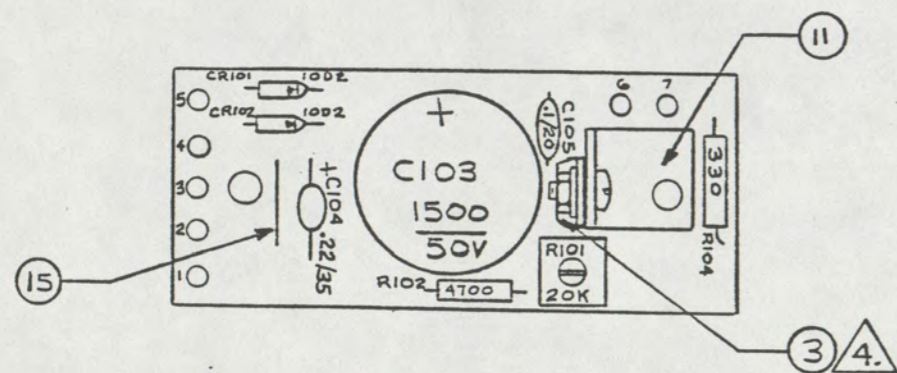
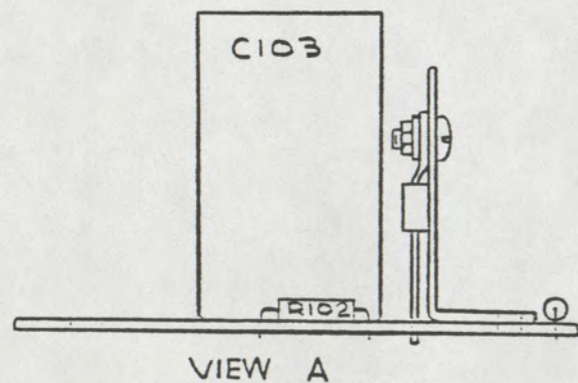

NOTES:

1. UNLESS OTHERWISE SPECIFIED RESISTOR VALUES ARE IN OHMS, 1/2W, 10%. CAPACITOR VALUES ARE IN MICROFARADS.
2. P.C. BOARD 51A5841-11
3. SCHEMATIC 91B7126
4. ASSEMBLE U101 (ITEM 3) TO HEATSINK (ITEM 11) USING A #6-32 X 1/4 SCREW, #6 LOCKWASHER, #6-32 NUT, (ITEMS 12, 13, 14), BEFORE INSTALLING U101 IN BOARD. USE HEATSINK COMPOUND (1590082) BETWEEN TAB OF U101 AND HEATSINK. HEATSINK SHOULD BE FLUSH WITH TOP OF P.C. BD. WHEN INSTALLED AS SHOWN IN VIEW A.

USED ON:  
RPL-3,4 RCVR

QTY.	DESCRIPTION	REF. DES.	STOCK NO.	ITEM NO.
1"	BUSS WIRE ALPHA 298 #22		1641927	15
1	NUT, SM. PATT. #6-32		1090554	14
1	WASHER, LOCK INT. TOOTH #6		1090562	13
1	SCREW B.H. SS. #6-32 X 1/4"		1090182	12
1	HEATSINK, MAI5A2827		2110286	11
1	RES. A.B. RC20GF330K 330Ω 1/2W 10%	R104	4420204	10
1	RES. A.B. RC20GF472K 4.7K 1/2W 10%	R102	4420345	9
1	POT. BOURNS 3389R-1-103 PC. BD. MOUNT 20K .5W	R101	4630349	8
1	CAP. CRL UK20/104 CER. DISC. .1μF 20V	C105	4310199	7
1	CAP. SPRAGUE 196D224X0035HAT EPOXY-DIP .22μF 35V 20%	C104	4280012	6
1	CAP. MEPCO 3427JJ152U050RM 1500 50V	C103	4350849	5
2	DIODE, I.R. 10D2	CR101,102	3610003	4
1	REGULATOR, FAIRCHILD 78GUIC	U101	3650231	3
7	TERMINAL, USECO 2520B	USED ON: 51A5841	3290707	2
1	PC. BD. MAI5A5841-11		3470025	1
*	POW. SUP. REGULATOR RCVR		9204462	*

ITEM 5 WAS 4350195  
ARTWORK WAS -00  
ECO 3980, 9-29-83 IF  
NEW RELEASE  
AFTER ECO 3469  
3 MAY 82 CH

MOSELEY ASSOCIATES, INC.  
SANTA BARBARA RESEARCH PARK  
GOLETA, CALIFORNIA 93017

COMPONENT LAYOUT  
POWER SUPPLY REGULATOR

TOL: FRACT. = 1/32, .XX = .030, .XXX = .010, < = 1/2"

DWN CAH 14 SEP 81 SCALE: FULL

CHK [Signature] 13-25-82

ENG [Signature] 17-25-82 20B2551 B

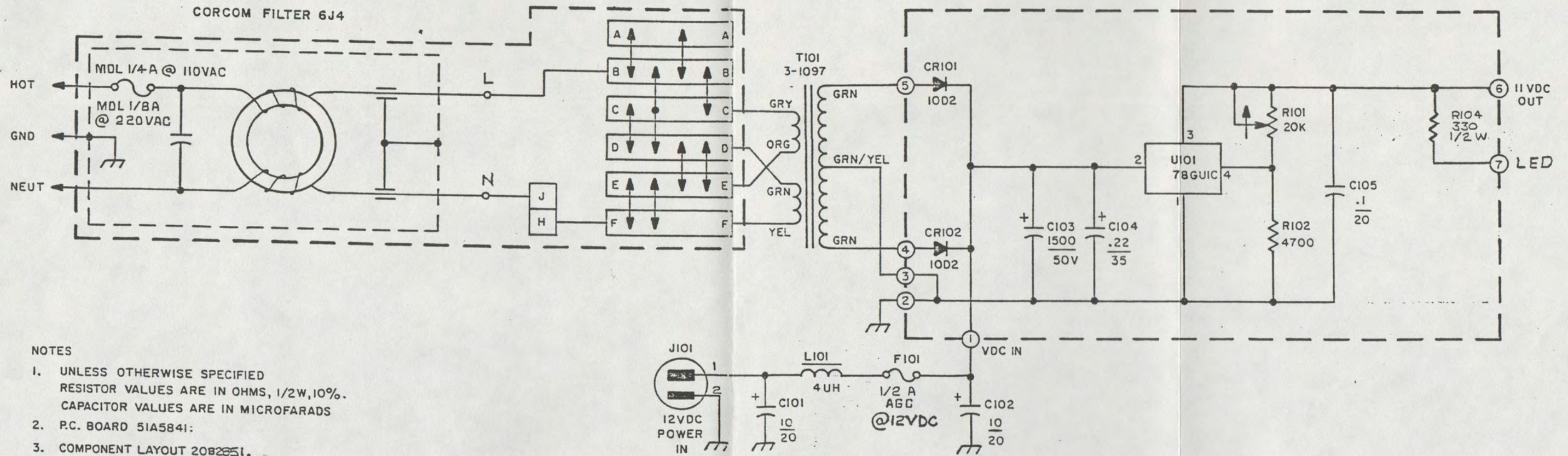

NOTES

- UNLESS OTHERWISE SPECIFIED RESISTOR VALUES ARE IN OHMS, 1/2W, 10%. CAPACITOR VALUES ARE IN MICROFARADS
- P.C. BOARD 51A5841:
- COMPONENT LAYOUT 2082851.

If You Didn't Get This From My Site,  
Then It Was Stolen From...  
www.SteamPoweredRadio.Com

2082851 WAS 2082740 IN NOTE 3. ECO 3469 3 MAY 82 CH	ADD: J101 PIN NOS., C104 POLARITY. 2082700 WAS "A" PCO3243 CH 4 DEC 81	REMOVED R103 & R104 ADDED NEW R104 PER ECO1986 15 JAN 81 CH	R105 & NOTE 5 REMOVED. FUSE VALUES ADDED. ECO1548 22 JAN 80 DT.W	ADDED CORCOM FILTER UNIT E7 JUN 78 ECO1275 A.J.B.	R101 WAS 25K. R101 WAS 5DEC78 F.X.Y.
---	---	---	--	--	---

<b>MOSELEY ASSOCIATES, INC.</b> SANTA BARBARA RESEARCH PARK GOLETA, CALIFORNIA 93017	
<b>SCHEMATIC</b> P. S. REGULATOR RCVR	
TOL: FRACT. = 1/32, .XX = .030, .XXX = .010, < = 1/2"	
DWN JAM 15 SEPT 78 CHK LAC 26 SEPT 78 ENG LAC 26 SEPT 78	SCALE: 9187126 E1

ITEM NUMBER: 9050170 \*\*\*\* S/P RPL-3 140-174 MHZ  
 MOSELEY ASSOCIATES, INC.  
 111 CASTILIAN DRIVE  
 GULETA, CA. 93117  
 (805) 968-9621

PAGE 1  
 DATE 8/20/85

KIT NUMBER: ST-80A

COMPONENT ITEM NO.	MANUFACTURER PART NUMBER	QTY PER
3600145	1N4154	6
	DIO 1N4154 25V 4NS SI D035	
3610003	10D2	4
	DIO 10D2 200V 1A SI D039	
3610045	5082-2835	1
	DIO 5082-2835 FAST	
3610151	MV-1624	2
	DIO MV-1624 020V 9-11PF D07	
3610193	VTL-5C2	1
	DIO VTL-5C2 LDR	
3610284	MDA2501	1
	DIO BRIDGE, 100V/25A	
3630001	2N918	2
	XT NS2N918 .4W00M030V50M2P	
3630035	2N3053	1
	XT NP2N3053 05W100M080V.7A	
3630076	2N3563	2
	XT NS2N3563 .2W600M030V50M2P	
3630159	2N3819	1
	XT NF2N3819 .4W 025V20M	
3630191	2N4037	2
	XT PP2N4037 01W060M060V01A	
3630233	2N4427	1
	XT NP2N4427 02W500M040V.4A	
3630241	2N4428	1
	XT NP2N4428 3.5W750M055V.42A	
3630308	2N5179	2
	XT NS2N5179 .2W900M020V50M1P	
3630365	2N5946	1
	XT NP2N5946 037W 036V02A	
3630399	3N140	1
	XT NF3N140 .4W 020V50M	
3630415	3N204	1
	XT NF3N204 .35W025V	
3640091	C3-12	1
	XT NPC3-12 010W470M017V01A	
3640182	MJ-2955	1
	XT PPMJ2955 115W2.5M060V15A	
3640224	TIP-32A	1
	XT PPTIP-32A 02W003M060V03A	
3650116	MC1723CL	1
	RGLTR MC1723CL VARV 0.15A 632	
3660008	UA741CP	2
	IC UA741P OPAMP GEN COMP	
3660024	UA748CP	2
	IC UA748P OPAMP UNCOMP	
3730173	LM-318N	1
	IC LM318N OPAMP HISPEED	

ITEM NUMBER: 9050170 \*\*\*\* S/P RPL-3 140-174 MHZ  
MOSELEY ASSOCIATES, INC.  
111 CASTILIAN DRIVE  
GOLETA, CA. 93117  
(805) 968-9621

PAGE 2  
DATE 8/20/85

KIT NUMBER: ST-30A

COMPONENT ITEM NO.	MANUFACTURER PART NUMBER	QTY PER
3730322	MC1350P IC MC1350P OPAMP	1
3730348	MC1355P IC MC1355P AMP FM/IF	1
3730335	UA739 IC UA739 OPAMP LONNOISE	1



ITEM NUMBER: 9050782 \*\*\*\* OP S/P RPL-3 RPU 140-174 MHZ  
MUSELEY ASSOCIATES, INC.  
111 CASTILIAN DRIVE  
GULETA, CA. 93117  
(805) 953-9621

PAGE 1  
DATE 5/23/85

KIT NUMBER: SO-80A

COMPONENT ITEM NO.	MANUFACTURER PART NUMBER	QTY PER
3370228	MDL 1/4 FUSE MDL-1/4 AMP (SLOW-BLO)	5
3370251	MDL 1 FUSE MDL-1 AMP (SLOW-BLO)	5
4090312	3-1088 AU XFMR 3-1088	1
4090338	3-1093A A XFMR 3-P-35 3-1093A	1
4350211	3143HA8020025 CAP 8000/25V	1

ITEM NUMBER: 9051277 \*\*\*\* OP CRYST RPL-3 140-174 MHZ  
MUSELEY ASSOCIATES, INC.  
111 CASTILIAN DRIVE  
GOLETA, CA. 93117  
(805) 968-9621

PAGE 1

KIT NUMBER: SX-80A

DATE 6/27/89

COMPONENT ITEM NO.	MANUFACTURER PART NUMBER	QTY PER
3340023	30A0016 D XTAL 40.7 MHZ RPL3/4, 101/505	1
3340411	30A0017 D XTAL RX 14L-230 MHZ RPL3, 101	1
3340635	30A0059 30 XTAL TX 140-174 MH RPL/101 65C	1

MUSELEY ASSOCIATES, INC.  
 111 CASTILIAN DRIVE  
 SOLETA, CA. 93117  
 (805) 968-9621

DATE 11/19/86

KIT NUMBER: ST-80A 08/16/85

COMPONENT ITEM NO.	MANUFACTURER NUMBER/ ITEM DESCRIPTION	QTY PER
3600145	1N4154 DIO 1N4154 25V 4NS SI D035	6
3610003	10D2 DIO 10D2 200V 1A SI D039	4
3610045	5082-2835 DIO 5082-2835 FAST	1
3610151	MV-1624 DIO VMV-1624 020V 9-11PF D07	2
3610193	VTL-5C2 DIO VTL-5C2 LDK	1
3610284	MDA2501 DIO BRIDGE 100V/25A	1
3630001	2N918 XT NS2N918 .4w600M030V50M2P	2
3630035	2N3053 XT NP2N3053 05w100M050V.7A	1
3630076	2N3563 XT NS2N3563 .2w600M030V50M2P	2
3630159	2N3819 XT NF2N3819 .4w 025V20M	1
3630191	2N4037 XT PP2N4037 01w060M060V01A	2
3630233	2N4427 XT NP2N4427 02w500M040V.4A	1
3630241	2N4428 XT NP2N4428 3.5w750M055V.42A	1
3630308	2N5179 XT NS2N5179 .2w900M020V50M1P	2
3630365	2N5946 XT NP2N5946 037W 036V02A	1
3630399	3N140 XT NF3N140 .4W 020V50M	1
3630415	3N204 XT NF3N204 .36w025V	1
3640091	C3-12 XT NPC3-12 010w470M017V01A	1
3640182	MJ-2955 XT PPMJ2955 115w2.5M060V15A	1
3640224	TIP-32A XT PPTIP-32A 02w003M060V03A	1
3650116	MC1723CL RGLTR MC1723CL VARV 0.15A 632	1
3660008	UA741CP IC UA741P OPAMP GEN COMP	2
3660024	UA748CP IC UA748P OPAMP UNCOMP	2
3730173	LM-318N IC LM318N OPAMP HISPEED	1

ITEM NUMBER: 9050170 #### S/P RPL-3 140-174 MHZ

PAGE 2

MOSELEY ASSOCIATES, INC.  
111 CASTILIAN DRIVE  
GULETA, CA. 93117  
(805) 968-9621

DATE 11/19/86

KIT NUMBER: ST-80A 08/16/85

COMPONENT ITEM NO.	MANUFACTURER NUMBER/ ITEM DESCRIPTION	QTY PER
3730322	MC1350P IC MC1350P OPAMP	1
3730348	MC1355P IC MC1355P AMP FM/IF	1
3730835	UA739 IC UA739 OPAMP LUNOISE	1

ITEM NUMBER: 9050782 \*\*\* OP S/P RPL-3 RPU 140-174 MHZ

PAGE 1

MUSELEY ASSOCIATES, INC.  
111 CASTILIAN DRIVE  
GOLETA, CA. 93117  
(805) 958-9621

DATE 11/19/86

KIT NUMBER: SD-80A 08/16/85

COMPONENT ITEM NO.	MANUFACTURER NUMBER/ ITEM DESCRIPTION	QTY PER
3370228	MDL 1/4 FUSE 1/4 AMP SLOW-BLO	5
3370251	MDL 1 FUSE 1 AMP SLOW-BLO	5
4090312	3-1086 AO XFMR	1
4090338	3-1093A A XFMR 8-P-86	1
4350211	3143HA8C2U025 CAP 8000/25V	1

ITEM NUMBER: 9051277 \*\*\*\* OP CRYSTAL RPL-3 140-174 MHZ

PAGE 1

MOSELEY ASSOCIATES, INC.  
111 CASTILIAN DRIVE  
GOLETA, CA. 93117  
(805) 968-9621

DATE 11/19/86

KIT NUMBER: SX-80A 03/16/85

COMPONENT ITEM NO.	MANUFACTURER NUMBER / - ITEM DESCRIPTION	QTY PER
3340023	30A0016 D XTAL 40.7 MHZ RPL3/4 101/505	1
3340411	30A0017 D XTAL RX 14L-230 MHZ RPL3, 101	1
3340635	30A0J59 80 XTAL TX 140-174 MH RPL/101 65C	1

## RPL-3, 4 TEST AND TUNE PPOCEDURE

PURPOSE

The purpose of this test procedure is to provide the technician with a step-by-step procedure for testing, tuning, and otherwise readying for shipment, the RPL-3 and 4, and, in addition, to provide sufficient familiarity with the operational characteristics of this particular system so that basic troubleshooting methods can be inferred.

TEST EQUIPMENT

1. Volt-Ohm Meter (such as Simpson Model 260).
2. Digital Volt Meter (such as Data Precision 1750).
3. One-GHz Frequency Counter (such as Anadex CF700A).
4. Wattmeter (such as Bird Model 43), with one-watt slugs for each frequency range, and 25-watt slugs for each frequency range.
5. Spectrum Analyzer (Tektronix 7603 with 7L12 plug-in).
6. Audio Oscillator (such as Hewlett-Packard 204C).
7. Signal Generator (Hewlett-Packard 8640).
8. Distortion Measurement System (Sound Technology 1070A, Hewlett-Packard 339A).
9. Oscilloscope.
10. Bolometer (such as Hewlett-Packard 430C).
11. Appropriate Instruction Manual.

PROCEDURE

PRELIMINARY NOTE: If the system is to operate on 220 VAC, plug it into 110 VAC and measure DC voltage across the large filter capacitor. This reading should be approximately 10 volts. If it is 20 volts, the system is wired for 110 VAC.

A. TRANSMITTER SETUP

NOTE: Applying power to the RPL-3, 4 Transmitter will cause carrier radiation if the RF circuits are properly aligned. It is therefore required that a 50 $\Omega$  termination, capable of dissipating 20 watts or more, be used to properly load the transmitter whenever the latter is powered up on the bench. When the emitted energy is being observed or used to test the transmitter-receiver system, this termination should be a 30-50 dB attenuator in order to protect the receiver and any test equipment receiving this radiation.

DEC 23 1993



REVISIONS	DATE	 <b>MOSELEY ASSOCIATES, INC.</b> SANTA BARBARA RESEARCH PARK GOLETA, CALIFORNIA 93017	
	MGMT. APPR.		
		RPL-3, 4 TEST AND TUNE PROCEDURE	
		TOL: FRACT. $\pm 1/32$ , .XX $\pm .030$ , .XXX $\pm .010$ , $\leq \pm 1/2^\circ$	
		DWN	SCALE: Page 1 of 12
		CHK	
		ENG	31A3147
			12-11-80

NOTE: This procedure is written for the RPL-4 at 450-470 MHZ. For the RPL-3 at 148-174 MHZ, refer to appropriate prints for component designations.

1. Attach a digital volt meter on its 0-50 VDC range between pin 9 of the power supply card and ground, and press the front panel power switch. If this reading is in excess of 15 volts, turn the transmitter off immediately and adjust R111 fully CCW. If VDC is  $\leq 15$  volts, adjust R111 for +11.5 VDC. Switch front panel metering to VCC and adjust R110 so that the meter reading agrees with the actual power supply voltage.
2. The next step is to set up the VCXO. For each channel, insert the appropriate crystal in its holder. Attach the VOM to brown TP1 and observe that the voltage is approximately .75 volts. Set the slugs in L1 and L2 to their minimum insertion position, and turn the slug in L1 slowly in. The oscillator should turn on at some point, resulting in a jump of the voltage at TP1 by about 0.2 volts. This condition can also be verified by observing the output of the VCXO on the spectrum analyzer. Energy will be observed at the fundamental 4-5 MHz frequency and many of its harmonics.

Continue to tune L1 and L2 for a maximum at TP1. Check the voltage at red TP2. This should be roughly 6 volts. Remove the crystal and make sure that the voltage at TP3 drops by several tenths of a volt. Reinstall the crystal. Repeat Step 2 for Channel 2, referring to VCXO drawings for parts designations. Test points are 4 (yellow) and 5 (green).

3. Connect the output of the multiplier driver module to the wattmeter using either VCXO channel. Use a one-watt slug at the carrier frequency. That this module is receiving sufficient drive can be ascertained by measuring at least 3 VDC at brown TP1. Move the VOM on the 0-2.5 VDC scale to red TP2. Using an inductor probe, loosely couple a spectrum analyzer to toroid L4. A spike should be measurable at 12-14 MHz. Tune C4, C11, and C14 for maximum amplitude of this spike. (Each of these adjustments should yield two maxima, indicating that required capacitance values are within range of these capacitors. If this condition is not observed, the VCXO may be operating on the wrong frequency.) Now tune C4, C11, and C14 for a maximum of about 0.5

REVISIONS MGMT. APPR.		<b>MOSELEY ASSOCIATES, INC.</b> SANTA BARBARA RESEARCH PARK GOLETA, CALIFORNIA 93017	
	RPL-3, 4 TEST AND TUNE PROCEDURE		
	TOL: FRACT. $\pm 1/32$ , .XX $\pm .030$ , .XXX $\pm .010$ , $\leq \pm 1/2^\circ$		
	DWN		SCALE: Page 2 of 12
CHK		31A3147	
ENG		12-11-80	



volts at TP2.

With VOM at orange TP3, adjust C17 and C19 for a maximum of about 0.8 VDC. Move the VOM to yellow TP4 and tune C23 and C25 for a maximum of about 0.9 VDC. With VOM at green TP5, adjust C28 and C41 for a maximum of about 0.5 VDC.

Open C38 and C39 about halfway. There should now be an indication on the wattmeter. Tune C38 and C39 for a maximum reading. If no indication is observed, a spectrum analyzer connected to the output of the wattmeter-attenuator should disclose a spike at the carrier frequency. If not, troubleshooting of the multiplier module is in order (see manual text & prints). The final output of the module should be >100 mw, with all undesired emissions at least 40 dB lower than the desired signal. Make sure a brass shield is installed over L11, L12, C38 and C39 and soldered to the ground plane; retune C38 and C39 if necessary. Switch operation to the alternate channel, and ascertain that the results achieved in this section are not significantly degraded. If the multiplier is not sufficiently broadbanded to operate at both frequencies, some slight readjustment of C4, C11, and C14 may be required.

4. We now turn our attention to the RF power amplifier. Refer to manual section VII.A.4 for a circuit description and parts designations for tuning purposes. The required specifications are listed in TABLE I. All spurious emissions must be  $\geq 60$ dB below carrier. The power amplifier is to be tuned to the above specifications (as measured with the amplifier's cover in place) with whatever fine give-and-take tuning as may be required, particularly in input and/or output stages. When tuning the output circuit, watch the final stage current draw carefully to avoid overheating the transistor. The multiplier module may be responsible for some spurious emissions, particularly within 100 MHz of the carrier, as may be ascertained by fine tuning of this module, starting at its output circuit.
5. Once a satisfactory emission has been attained, the P.A. cover should be installed. Check front panel forward and reverse power metering for upper-mid and near-zero readings respectively. Then check the transmitter carrier frequency with the one-GHz counter, and vary L1 and L2, and L6 and L7, in turn, to produce the assigned carrier frequencies. If very large adjustments seem to

REVISIONS MGMT. APPR.	DATE	 <b>MOSELEY ASSOCIATES, INC.</b> SANTA BARBARA RESEARCH PARK GOLETA, CALIFORNIA 93017	
		RPL-3, 4 TEST AND TUNE PROCEDURE	
		TOL: FRACT. $\pm 1/32$ , .XX $\pm .030$ , .XXX $\pm .010$ , $\leq \pm 1/2^\circ$	
		SCALE: Page 3 of 12	
	DWN		
	CHK		
	ENG	JH 12-11-80	31A3147

be necessary, vary R60 or R15 as needed, increasing for higher frequency, to put the carrier frequency within range. Finally, check to see that the crystal ovens are operating. The voltage as measured at the upper pin of the oven should fluctuate. If it is fixed at zero or some positive voltage, the oven or its driver transistor is defective. This completes the initial transmitter setup.

## B. RECEIVER SETUP

1. Apply AC power to the receiver, and adjust R101 on the power supply board for +11.5VDC at pin 6.
2. We begin by aligning the receiver's output section. Attach the balanced audio output connections on the receiver's rear barrier strip to the distortion analyzer input. (Since the latter has high input impedance, bridging the balanced connection with 600  $\Omega$  will properly load the receiver.) Inject a 10.7 MHz signal into the FM demodulator module. Use a level of 3000  $\mu$ V and modulate 100% (see TABLE I) with a 700 Hz tone. Set the distortion analyzer on its "voltmeter" position, input level +10 dBm. Set audio level pot R26 about halfway and squelch pot R6 fully clockwise (disabled). If this setup yields no response on the meter, attach an oscilloscope to one side of the output; a sine wave should be visible at 700 Hz. If not, move the oscilloscope to pin 3 of the demodulator and/or inject a 700 Hz tone at 0.5 V p-p into the audio board at pin 2 to locate the fault.

We first maximize the resulting output by alternately tuning the pink and blue slugs on the demodulator, and then adjust R26 for an output of +10 dBm. Then, adjust the blue slug carefully for minimum total harmonic distortion (THD) while correcting for level changes with R26. THD should be less than 0.5% at 700 Hz. Measure signal-to-noise ratio (SNR); this figure should be at least 62 dB. Measure the level necessary for 60 dB SNR and compare with TABLE III.

3. We now turn our attention to the receiver's RF and IF sections. If the receiver has a preselector (RPL-4, 450 MHz version), we will measure its insertion loss. If not, skip to section B5. First, set a reference on the spectrum analyzer with an unmodulated signal at the carrier frequency. Signal level should be around 500  $\mu$ V, and should be adjusted until an increase in the

REVISIONS MGMT. APPR.	DATE	 <b>MOSELEY ASSOCIATES, INC.</b> SANTA BARBARA RESEARCH PARK GOLETA, CALIFORNIA 93017	
		RPL-3, 4 TEST AND TUNE PROCEDURE	
		TOL: FRACT. $\pm 1/32$ , .XX $\pm .030$ , .XXX $\pm .010$ , $\angle \pm 1/2^\circ$	
		DWN	SCALE: Page 4 of 12
	CHK	31A3147	
	ENG	<i>LA</i>	12-11-80

analyzer's RF attenuation control causes a corresponding decrease in the magnitude of its vertical display; this insures that the vertical amplifier is not in saturation. (Absolute and relative level measurements on a spectrum analyzer should always be made with the "sweep rate" control in its "Spectrum" position (with Tektronix analyzers) or in the "msec", or frequency domain mode on the AIL.) Once this reference has been set, insert the preselector into the signal chain and measure the loss thus incurred. This figure should be less than 4 dB (see TABLE II), and will require tuning of the three tuning capacitors, C101, C102 and C103. If insertion loss is still greater than 4 dB, loosen the nut on the output connector and, with corresponding adjustment of C103, find the optimum position of this connector. Tighten the nut when this is complete, and retune.

We now measure the gain of the preamp. Leave the signal at the receiver input, and add the preamp to the signal chain. Measure the combined gain of the preselector/preamp combination. It should be at least +10 dB (see TABLE II). Since these receiver versions do not contain adjustable preamps, combined gain less than +10 dB may require troubleshooting or replacement of the preamp if the complete receiver does not meet sensitivity specifications.

4. We now adjust the receiver's local oscillator. One channel at a time must be selected on the front panel, and the appropriate crystal installed. The crystal frequency is given by

$$F_c = \frac{30.000 \text{ MHZ}}{6}$$

For channel 1, C103 tunes the frequency of the oscillator and C108 tunes its output tank. The adjustments which follow, C121, C126, C130, C133 and C134, are common to both channels. The output for each channel should be peaked at 5 milliwatts or more, (2 milliwatts for the RPL-3) and should be free of spurious responses within about 50 MHZ.

Inject one of these signals, together with the output of the preamp (or the signal generator at the appropriate carrier frequency, no modulation, level 500  $\mu$ V) into the first converter or balanced mixer module. Observe the output of the latter on the spectrum



DATE	 <b>MOSELEY ASSOCIATES, INC.</b> SANTA BARBARA RESEARCH PARK GOLETA, CALIFORNIA 93017		
	RPL-3, 4 TEST AND TUNE PROCEDURE		
REVISIONS MGMT. APPR.	TOL: FRACT. $\pm 1/32$ , .XX $\pm .030$ , .XXX $\pm .010$ , $\angle \pm 1/2^\circ$		
	DWN		SCALE: Page 5 of 12
	CHK		31A3147
	ENG	<i>27</i>	12-11-80

analyzer. Adjust signal level if necessary so that the amplifiers in these modules are not in saturation (i.e., variations in input level result in corresponding variations in output level). Tune all variable capacitors and/or coils for maximum output. Conversion gain should be at least +35 dB (see TABLE II). Remove the input carrier signal from the module, and verify that no oscillations appear on the analyzer screen. Re-apply the signal, and verify that no unwanted radiation appears at any frequency. If these unwanted conditions are apparent on the 450 MHz version (20A2735), back off the slug in T1 until oscillations disappear. Retune the rest of the module for maximum gain.

Now insert this output into the 30-10.7 MHz converter, and observe the output of this module. (In the RPL-3, 150 MHz model, a mechanical 30 MHz bandpass filter intervenes. Its insertion loss should be less than 4 dB.) Set R13 about halfway and tune L1, T1, T2, and T3 for maximum output. C6 tunes the 40.7 MHz oscillator's tank circuit and is very narrow in its adjustment. C8 sets the oscillator frequency, and can be adjusted to produce an output at exactly 10.7 MHz. (The L-C 10.7 MHz filter patches into this module, and can be bypassed with a jumper to localize difficulties.) Conversion gain should be in excess of +60 dB (avoid saturation). See TABLE II.

5. We now inject this 10.7 MHz carrier into the FM demodulator. Modulate 100% at 700 Hz, 1000  $\mu$ V level into the receiver input connector. Audio level out should be +10 dBm. Adjust R28 so that audio level out at 2 KHz modulating frequency is 3 dB below this level. Return audio to 700 Hz. Measure SNR; this figure should be at least 60 dB. Find the input signal level necessary for 60 dB SNR. This level should be less than 250  $\mu$ V. Measure level necessary for 45 dB SNR. This is the measure of the sensitivity of the receiver, and should be less than 30  $\mu$ V. Measure THD at 70, 700, 3000, 7000, 10,000, and 15,000 Hz modulating frequencies (the last only on RPL-4B, 15,000 Hz audio systems). This figure must be less than 1% at all frequencies, and should remain so for signal levels up to about 10,000  $\mu$ V and down to roughly 10  $\mu$ V where the noise level begins to take over.

Increase signal level to 10,000  $\mu$ V and observe front panel "limiter", or signal-strength metering. If it is off scale, pad the circuit by attaching a resistor (560  $\Omega$  typical) between the

REVISIONS MGMT. APPR.	DATE	 <b>MOSELEY ASSOCIATES, INC.</b> SANTA BARBARA RESEARCH PARK GOLETA, CALIFORNIA 93017	
		RPL-3, 4 TEST AND TUNE PROCEDURE	
		TOL: FRACT. $\pm 1/32$ , .XX $\pm .030$ , .XXX $\pm .010$ , $\angle \pm 1/2^\circ$	
		DWN	SCALE: Page 6 of 12
		CHK	31A3147
	ENG	 12-11-80	

input and ground of the meter so that the meter reads 8-10. Next, remove the signal entirely and observe the meter. Adjust R13 on the 30-10.7 MHz converter module so that the meter reads less than 2, and so that it begins to rise at 3  $\mu$ V signal level. Now complete the portion of the test data sheet entitled "Receiver Meter Readings" by measuring SNR and observing the meter for the specified signal levels.

- Set the receiver squelch with R6 on the audio board so that muting will occur when the signal level falls below that required for 45 dB SNR. Complete the squelch entry on the data sheet and slip R6. Secure covers on all subassemblies. This completes the receiver setup.

C. SYSTEM TUNING

- Our task now is to mate the transmitter and receiver. Attach the output of the wattmeter-attenuator to the receiver input connector, and apply power to the transmitter.

Complete the multi-driver section of the transmitter test point readings on the data sheet, and secure the cover to the module.

- Insert a 700 HZ tone at -15 dBm into the line input on the side of the transmitter. Set the metering pots R66, R47, and R51 on audio board fully counterclockwise. With the front panel metering switch in "peak audio" position, increase the front panel "line" pot until limiting just occurs (the meter should read 7 to 8). Adjust R47 for a meter reading of +1 $\frac{1}{2}$  dB. Turn "line" pot fully counterclockwise and zero the meter with R66.

Make sure that channel 1 is selected on both transmitter and receiver, and turn the "line" pot up for a meter reading of 0 dB. Adjust R35 for +10 dBm out of the receiver.

Now switch the modulating tone to 3000 Hz, and measure THD. (3000 Hz is typically the frequency at which highest THD is measured.) For each channel, final tuning of the VCX0 is performed (with the tuning cover on) so that THD is  $\leq 1.3\%$  from 50 to 10,000 Hz (15,000 HZ for the RPL-4B) while the transmitter fre-

REVISIONS	DATE	 <b>MOSELEY ASSOCIATES, INC.</b> SANTA BARBARA RESEARCH PARK GOLETA, CALIFORNIA 93017	
	MGMT. APPR.		
	RPL-3, 4 TEST AND TUNE PROCEDURE		TOL: FRACT. $\pm 1/32$ , .XX $\pm .030$ , .XXX $\pm .010$ , $\leq \pm 1/2^\circ$
	DWN		SCALE: Page 7 of 12
CHK		31A3147	
ENG	<i>JH</i>	12-11-80	

quency is kept within .00025% of its assigned value with L1 and L2 (for channel 1). At the same time, adjust the receiver de-emphasis with R28 on the audio board and readjust it if necessary so that the audio response is + 1.5 dB relative to 700 Hz level from 50 to 10,000 HZ (15,000 HZ for the RPL-4B). The juggling of these adjustments can be tricky and should be done slowly and carefully. If this procedure requires very large adjustments of the tuning slugs, or if the VCXO will not oscillate at the assigned frequency, two solutions may be attempted. First, since the DC voltage at the junction of diodes CR1 and CR2 controls the frequency of the VCXO, this bias may be altered by changing the value of R15, perhaps to 1500 or 1800 $\Omega$ . Second, since the tank circuit consisting of L1, C10, C11 and R16 determines the crystal oscillator frequency, C10 can be varied to alter the tuning range of L1. Values of 100 pf or so are typical. Otherwise, troubleshooting may be necessary.

When this procedure is complete, slight frequency adjustments may be performed with L2 without disturbing the THD and audio response performance. Drip a small amount of melted wax into L1 to seal it.

Repeat the last two paragraphs for channel 2, and readjust R28 in the receiver if necessary for the best balance for both channels.

3. Complete the "System Performance" section of the test data sheet. Measure the audio volts p-p at brown TP1 and yellow TP4 on the VCXO card with 100% modulation at 700 Hz, and the DC voltages at TP1, TP3, TP4 and TP5. Enter these values on the test data sheet. Secure the cover to the VCXO. Then enter the transmitter meter readings on the data sheet. Measure the SNR for 100% modulation, and enter this value on the data sheet. Minimum for this value is 60 dB. Set the meter acceleration with R51 on the transmitter audio board so that a step function input at the transmitter audio input produces a 1-dB overshoot of the program metering. Glip all pots. This completes the tuning of the system.
4. An additional method for locating receiver trouble spots is available. This consists of working backwards from the FM Demodulator in order to verify that each individual module does not add any significant degradation of performance to the system

REVISIONS MGMT. APPR.	DATE	 <b>MOSELEY ASSOCIATES, INC.</b> SANTA BARBARA RESEARCH PARK GOLETA, CALIFORNIA 93017	
		RPL-3, 4 TEST AND TUNE PROCEDURE	
		TOL: FRACT. $\pm 1/32$ , .XX $\pm .030$ , .XXX $\pm .010$ , $\angle \pm 1/2^\circ$	
	DWN		SCALE: Page 8 of 12
	CHK		
	ENG	JH	12-11-80 31A3147

as a whole. Using TABLE III as a guide, inject the appropriate signal level and frequency into the input of each successive module until performance no longer meets typical specifications.

REVISIONS MGMT. APPR.	 <b>MOSELEY ASSOCIATES, INC.</b> SANTA BARBARA RESEARCH PARK GOLETA, CALIFORNIA 93017	
	RPL-3, 4 TEST AND TUNE PROCEDURE	
	TOL: FRACT. $\pm 1/32$ , .XX $\pm .030$ , .XXX $\pm .010$ , $\angle \pm 1/2^\circ$	
	DWN	SCALE: Page 9 of 12
CHK	31A3147	12-11-80
ENG	31A3147	12-11-80

TABLE II

MODULE	INPUT FREQUENCY	OUTPUT FREQUENCY	GAIN (CONVERSION) (TYPICAL VALUES)
Preselector (450 model)	Carrier	Carrier	-3.5 db
Preamp (450 model)	Carrier	Carrier	+14 dB
1st Converter (150 model)	Carrier + 1.0. (30 MHz below carrier)	30 MHz	+35 dB
Balanced Mixer (450 model)	Carrier + 1.0. (30 MHz below carrier)	30 MHz	+40 dB
30-10.7 Conv.	30 MHz	10.7 MHz	+60 dB

REVISIONS	DATE	MOSELEY ASSOCIATES, INC.	
	MGMT. APPR.	SANTA BARBARA RESEARCH PARK GOLETA, CALIFORNIA 93017	
RPL-3, 4 TEST AND TUNE PROCEDURE			
TOL: FRACT. $\pm 1/32$ , .XX $\pm .030$ , .XXX $\pm .010$ , $\angle \pm 1/2^\circ$			
DWN		SCALE:	Page 11 of 12
CHK		31A3147	
ENG	JH	12-11-80	

If You Didn't Get This From My Site,  
Then It Was Stolen From...  
www.SteamPoweredRadio.Com



TABLE III

<u>POINT OF INJECTION</u>	<u>SIGNAL LEVEL</u>	<u>TYPICAL THD (700 Hz)</u>	<u>TYPICAL LEVEL NEEDED FOR 60 dB SNR</u>
FM Demod	3000 $\mu$ V	0.5%	1200-1400 $\mu$ V
30-10.7 Conv.	500 $\mu$ V	0.4%	130-150 $\mu$ V
1st Conv.	500 $\mu$ V	0.35%	300-400 $\mu$ V
Preamp	500 $\mu$ V	0.35%	100-200 $\mu$ V
Preselector	500 $\mu$ V	0.30%	150-250 $\mu$ V



REVISIONS MGM. APPR.	DATE	 <b>MOSELEY ASSOCIATES, INC.</b> SANTA BARBARA RESEARCH PARK GOLETA, CALIFORNIA 93017
	RPL-3, 4 TEST AND TUNE PROCEDURE	
TOL: FRACT. $\pm 1/32$ , .XX $\pm .030$ , .XXX $\pm .010$ , $\angle \pm 1/2^\circ$		SCALE: Page 12 of 12
DWN		31A3147
CHK		
ENG	[Signature] 12-11-80	

TABLE I

<u>FREQUENCY BAND</u>	<u>DEVIATION FOR 100% MOD.</u>	<u>TX POWER OUTPUT</u>	<u>TX FINAL CURRENT</u>
148-172 MHZ	5 KHZ	10-15 W	< 2 amps
450-470 MHZ	5 KHZ (10 KHZ for RPL-4B)	10-15 W	< 2 amps

REVISIONS MGMT. APPR.	DATE	 <b>MOSELEY ASSOCIATES, INC.</b> SANTA BARBARA RESEARCH PARK GOLETA, CALIFORNIA 93017		
	RPL-3, 4 TEST AND TUNE PROCEDURE			
	TOL: FRACT. ± 1/32, .XX ± .030, .XXX ± .010, < ± 1/2°		SCALE: Page 10 of 12	
	DWN CHK ENG	[Signature] 12-11-80	31A3147	

If You Didn't Get This From My Site,  
Then It Was Stolen From...  
[www.SteamPoweredRadio.Com](http://www.SteamPoweredRadio.Com)