



**Moseley**

---

***CIP-2L  
COMMAND INTERFACE PANE***

# ***Technical Manual***

## ***CIP-2L COMMAND INTERFACE PANEL***

First Edition  
September 1988

7A0065 REV A



Moseley  
Associates  
Incorporated

111 Castilian Drive  
Santa Barbara, CA  
93117-3093

Phone 805 968 9621  
Telex 658448  
Fax 805 685 9638

**Copyright © 1988 by Moseley Associates, Inc.  
All rights reserved**



# WARRANTY

All equipment designed and manufactured by Moseley Associates, Inc. is warranted against defects in workmanship and material that develop under normal use within a period of (2) years from the date of original shipment, and is also warranted to meet any specifications represented in writing by Moseley Associates, Inc., so long as the purchaser is not in default under his contract of purchase and subject to the following additional conditions and limitations:

1. The sole responsibility of Moseley Associates, Inc. for any equipment not conforming to this Warranty shall be, at its option:

A. to repair or replace such equipment or otherwise cause it to meet the represented specifications either at the purchaser's installation or upon the return thereof f.o.b. Santa Barbara, California, as directed by Moseley Associates, Inc.; or

B. to accept the return thereof f.o.b. Santa Barbara, California, credit the purchaser's account for the unpaid portion, if any, of the purchase price, and refund to the purchaser, without interest, any portion of the purchase price theretofore paid; or

C. to demonstrate that the equipment has no defect in workmanship or material and that it meets the represented specification, in which event all expenses reasonably incurred by Moseley Associates, Inc., in so demonstrating, including but not limited to costs of travel to and from the purchaser's installation, and subsistence, shall be paid by purchaser to Moseley Associates, Inc.

2. In case of any equipment thought to be defective, the purchaser shall promptly notify Moseley Associates, Inc., in writing, giving full particulars as to the defects. Upon receipt of such notice, Moseley Associates, Inc. will give instructions respecting the shipment of the equipment, or such other manner as it elects to service this Warranty as above provided.

3. This Warranty extends only to the original purchaser and is not assignable or transferable, does not extend to any shipment which has been subjected to abuse, misuse, physical damage, alteration, operation under improper conditions or improper installation, use or maintenance, and does not extend to equipment or parts not manufactured by Moseley Associates, Inc. and such equipment and parts are subject to only adjustments as are available from the manufacturer thereof.

4. NO OTHER WARRANTIES, EXPRESS OR IMPLIED, SHALL BE APPLICABLE TO ANY EQUIPMENT SOLD BY MOSELEY ASSOCIATES, INC. AND NO REPRESENTATIVE OR OTHER PERSON IS AUTHORIZED BY MOSELEY ASSOCIATES, INC. TO ASSUME FOR IT ANY LIABILITY OR OBLIGATION WITH RESPECT TO THE CONDITION OR PERFORMANCE OF ANY EQUIPMENT SOLD BY IT, EXCEPT AS PROVIDED IN THIS WARRANTY. THIS WARRANTY PROVIDES FOR THE SOLE RIGHT AND REMEDY OF THE PURCHASER AND MOSELEY ASSOCIATES, INC. SHALL IN NO EVENT HAVE ANY LIABILITY FOR CONSEQUENTIAL DAMAGES OR FOR LOSS, DAMAGE OR EXPENSE DIRECTLY OR INDIRECTLY ARISING FROM THE USE OF EQUIPMENT PURCHASED FROM MOSELEY ASSOCIATES INC.

# WARRANTY

All other warranties, including those made by the manufacturer, are hereby disclaimed. The only warranty is the warranty of merchantability. The product is warranted to be free from defects in material and workmanship for a period of (1) years from the date of original shipment, and is also warranted to meet the performance represented in writing by the manufacturer. The warranty is void in states where the laws of such state conflict with the following conditions, limitations and exclusions.

The sole responsibility of the manufacturer is to provide a product that is free from defects in material and workmanship for a period of (1) years from the date of original shipment.

A. In no event shall the manufacturer be liable for consequential or special damages, including but not limited to, lost profits, lost income, lost business, or any other damages, arising out of the use of the product, even if such damages were foreseeable at the time of shipment.

B. In no event shall the manufacturer be liable for any damages, including but not limited to, lost profits, lost income, lost business, or any other damages, arising out of the use of the product, even if such damages were foreseeable at the time of shipment, if the product was used in a manner not intended by the manufacturer.

C. In no event shall the manufacturer be liable for any damages, including but not limited to, lost profits, lost income, lost business, or any other damages, arising out of the use of the product, even if such damages were foreseeable at the time of shipment, if the product was used in a manner not intended by the manufacturer, and if the user failed to read and follow the instructions for use.

D. In no event shall the manufacturer be liable for any damages, including but not limited to, lost profits, lost income, lost business, or any other damages, arising out of the use of the product, even if such damages were foreseeable at the time of shipment, if the product was used in a manner not intended by the manufacturer, and if the user failed to read and follow the instructions for use, and if the user failed to use the product in accordance with the instructions for use.

E. The manufacturer's liability is limited to the original purchase price of the product. The manufacturer shall not be liable for any damages, including but not limited to, lost profits, lost income, lost business, or any other damages, arising out of the use of the product, even if such damages were foreseeable at the time of shipment, if the product was used in a manner not intended by the manufacturer, and if the user failed to read and follow the instructions for use, and if the user failed to use the product in accordance with the instructions for use.

F. NO OTHER WARRANTIES, EXPRESS OR IMPLIED, SHALL BE GIVEN BY THE MANUFACTURER. THE MANUFACTURER SHALL NOT BE LIABLE FOR ANY DAMAGES, INCLUDING BUT NOT LIMITED TO, LOST PROFITS, LOST INCOME, LOST BUSINESS, OR ANY OTHER DAMAGES, ARISING OUT OF THE USE OF THE PRODUCT, EVEN IF SUCH DAMAGES WERE FORESEEABLE AT THE TIME OF SHIPMENT, IF THE PRODUCT WAS USED IN A MANNER NOT INTENDED BY THE MANUFACTURER, AND IF THE USER FAILED TO READ AND FOLLOW THE INSTRUCTIONS FOR USE, AND IF THE USER FAILED TO USE THE PRODUCT IN ACCORDANCE WITH THE INSTRUCTIONS FOR USE.



## CIP-2L COMMAND INTERFACE PANEL

Schematic 91D7447  
Assembly 21D2681  
Component Layout 20C3027

### 1. PURPOSE

The CIP-2L Command Interface Panel is designed to provide a simple control interface for use with Moseley MRC Microprocessor-Based Remote Control Systems. When used in conjunction with an Open Collector or an Optically-Isolated Output Board, up to 16 momentary or eight latching control relays may be operated in a single Command Interface Panel. Both normally-open and normally-closed relay contacts are available at each relay position. Unregulated dc power is also available at the spare power terminals for user convenience.

### 2. SPECIFICATIONS

The CIP-2L Command Interface Panel is designed to operate in conjunction with the MRC Open Collector Output Board, 20C2755-1, or the Optically-Isolated Output Board, 20B2705.

**WARNING:** Improper operation will result if the CIP-2L is used in conjunction with the Modified Open Collector Output Board, 20C2755-2.

#### Outputs

Number of Relays	Up to 16 momentary, or up to 8 latching
Number of Contacts	2 Form C per relay
Termination	Wire-clamp terminal strips
Initial Contact Resistance	100 milliohm maximum
Contact Rating (Resistive Load)	5A @ 125 Vac, 250 Vac or 30 Vdc
Contact Rating (Inductive Load)	1/10 hp @ 125 Vac or 250 Vac

Maximum Operating Speed	50 c/s
Operate Time	Approximately 10 ms
Release Time	Approximately 5 ms
Spare Power Output Voltage	+28 V unregulated
Spare Power Output Current	25 mA to 281 mA depending on the number of relays installed in the CIP-2L

**CAUTION:** See Section 4, INSTALLATION, in this manual for limitations on current demands above 25 mA.

### Inputs

Number of Inputs	16 active lines and 16 ground returns
Termination	37-pin "D" connector
Drive Requirements	An open collector (or switch to ground) able to withstand +35V open circuit voltage and 22 mA short circuit current for each relay. These drive requirements are met when the CIP-2L is driven by the Open Collector Output Board, 20C2755-1, or the Optically-Isolated Output Board, 20B2705.
Power Requirements	120 Vac or 240 Vac $\pm 10\%$
Operational Temperature Range	0° C to +50° C

### 3. UNPACKING

The CIP-2L should be carefully unpacked and inspected for any shipping damage. Keep all packing material until performance is verified. Should inspection reveal shipping damage, or should hidden damage be revealed, immediately file a claim with the carrier. This inspection should include ascertaining that all the various components are mechanically secure.



#### 4. INSTALLATION

Prior to installation of the CIP-2L, ensure that all relays are mechanically secure in their sockets.

The CIP-2L comes factory-wired for 120 Vac operation. If 240 Vac operation is desired, the primary lines of the power transformer can be reconnected, as shown on the schematic. These lines are located on the power barrier strip next to the fuse holder. Extra space is provided for the 240 Vac connection.

The CIP-2L Command Interface Panel is designed to be rack-mounted within two feet of the MRC. The unit comes supplied with extender brackets which are useful for rear rack mounting configurations. However, these extender brackets can be removed when the CIP-2L will be mounted on the front of a rack.

After the CIP-2L is secured to the rack, its input "D" connector should be connected to the output of the appropriate filtered I/O board. In turn, this I/O board should be connected to either an Open Collector Output Board, 20C2755-1, or an Optically-Isolated Output Board, 20B2705.

**CAUTION:** Improper operation will result if the CIP-2L is used in conjunction with the Modified Open Collector Output Board, 20C2755-2.

AC power may now be connected to the CIP-2L.

The CIP-2L relay outputs are located on the six-position terminal strips which are situated along the top and bottom of the PC board. These terminal strips are electrically connected to the relay contacts and are labeled K1 through K16.

The CIP-2L will accept both latching and momentary relays. Latching relays can be installed at locations K1, K3, K5, K7, K9, K11, K13 and K15. If a latching relay is installed, the next higher location K2, K4, K6, K8, K10, K12, K14, or K16 must be left open to ensure proper operation. For example, if K5 is a latching relay, K6 must be left open. When a latching relay is installed, two adjacent momentary (or pulsed) command lines are required for operation. Continuing our example above, a "Raise" issued on Command Line 5 will latch (set) relay K5. A "Lower" issued on Command Line 6 will unlatch (reset) relay K5.

For momentary relays, K1 is actuated by Command Line 1 from the Command Output Board. K2 through K16 are controlled, respectively, by Command Lines 2 through 16. If more than one CIP-2L is used, then K1 through K16 on the second CIP-2L are controlled, respectively, by Command Lines 17 through 32 from the second Command Output Board.



Each relay output has two sets of three connections associated with it: "C", or common line; "NO", or normally-open contact; and "NC", or normally-closed contact. "Normally", in this case, indicates the relationship between the relay contacts and the common line when the relay coil is not energized. Lines to the externally-controlled equipment should be connected to the appropriate relay terminal strip. These terminal strips feature wire-clamping screws which eliminate the need to lug wires. For 5-ampere service, use at least 16-gauge wire.

Spare DC power is available at the spare power terminal block located on the CIP-2L PC board. The voltage at these terminals is 28 Vdc unregulated with an output current capability between 25 mA and 281 mA, depending on the number of relays installed in the CIP-2L. A formula for determining the allowable spare power current capability for a given number of relays is:

$$I(\text{mA}) = 281 - N * 16$$

where N is the number of relays installed. For example, if the CIP-2L contains eight relays, a maximum of 153 mA can be drawn from the spare power terminals.

## 5. THEORY OF OPERATION

The following description is with reference to the schematic.

Transformer T1, in conjunction with diodes CR17, CR18 and filter capacitor, C3, form a full-wave 28 Vdc unregulated power supply with sufficient capacity for powering sixteen 16 mA relays. Capacitors C1, C2 and C4 perform the function of RF filtering, while resistor R1 improves the load regulation of the power supply. Since the full current capability of the supply is not needed for driving relays, external access to the supply is provided through the spare power terminals and fuse F1. The amount of current that can be drawn from this source (which depends on the number of relays installed in the CIP-2L) is defined in Section 4, INSTALLATION.

To conserve space, the relays used in the CIP-2L are magnetically (as opposed to mechanically) biased. This requires that coil power be of proper polarity. Therefore, the positive line of the power supply connects to the positive coil inputs on relays K1 through K16. Diodes CR1 through CR16 serve as transient snubbers to suppress turnoff transients which might otherwise damage the relay drivers.

The negative coil lead of each relay is brought out to a 37-pin "D" connector. Pins 1 through 16 of this connector are connected respectively to relays K1 through K16, and pins 20 through 35 function as ground returns. Relay K1 will be activated by a low



impedance connection between pins 1 and 20. This connection may be affected by an open collector gate or a switch. The worst case open circuit voltage across these pins is 35 Vdc. The worst case short circuit current through these pins is 22 mA. The other relay control pins function similarly.

## 6. TROUBLESHOOTING

### **6.1 Partial Failure (Some Relays Work)**

This indicates that the CIP-2L power supply is operating correctly. One possible problem could be a faulty relay. Try exchanging this relay with one from a functioning channel. If the bad channel still does not work, determine if the relay is pulling in (there should be an audible click upon activation). If the relay is pulling in but there is no change in the output, then the problem is a break between the relay contacts and the output barrier strip. However, if the relay is not changing state on command, there is either a fault in the CIP-2L or the MRC Command Output Board. A test to isolate the unit at fault is as follows:

Disconnect the CIP-2L "D" connector from its mating "D" plug on the filtered I/O board and carefully inspect the pins on both connectors. If, for example, relay K4 were inoperative, use a small screwdriver and short pins 4 and 23 in the CIP-2L "D" connector together. If the relay operates properly under this condition, the problem lies either in the MRC Command Output or filtered I/O board, and their respective manuals should be consulted. However, if the relay still does not operate, then there is likely an open or short in the PC board trace or the connector cable of the CIP-2L that corresponds to this relay.

### **6.2 Complete Failure (No Relays Work)**

The most probable cause of this condition is the power supply. Check the connection to ac mains and fuses F1 and F2. The voltage at the spare power terminals should be 28V +/- 5.6 Vdc.

If the power supply is functioning properly, then the fault is either a faulty Command Output Board or an improperly connected system. Check the CIP-2L connections to the MRC with reference to Section 4, INSTALLATION. If this seems normal, then troubleshoot the appropriate Command Output Board with reference to its manual.

**CAUTION:** Improper operation will result if the CIP-2L is used in conjunction with the MRC Modified Open Collector Output Board, 20C2755-2. Refer to Section 2, SPECIFICATIONS, for proper Command Output Board selection.



Figure 1  
CIP-2L Relay Board Schematic  
91D7447 Rev A

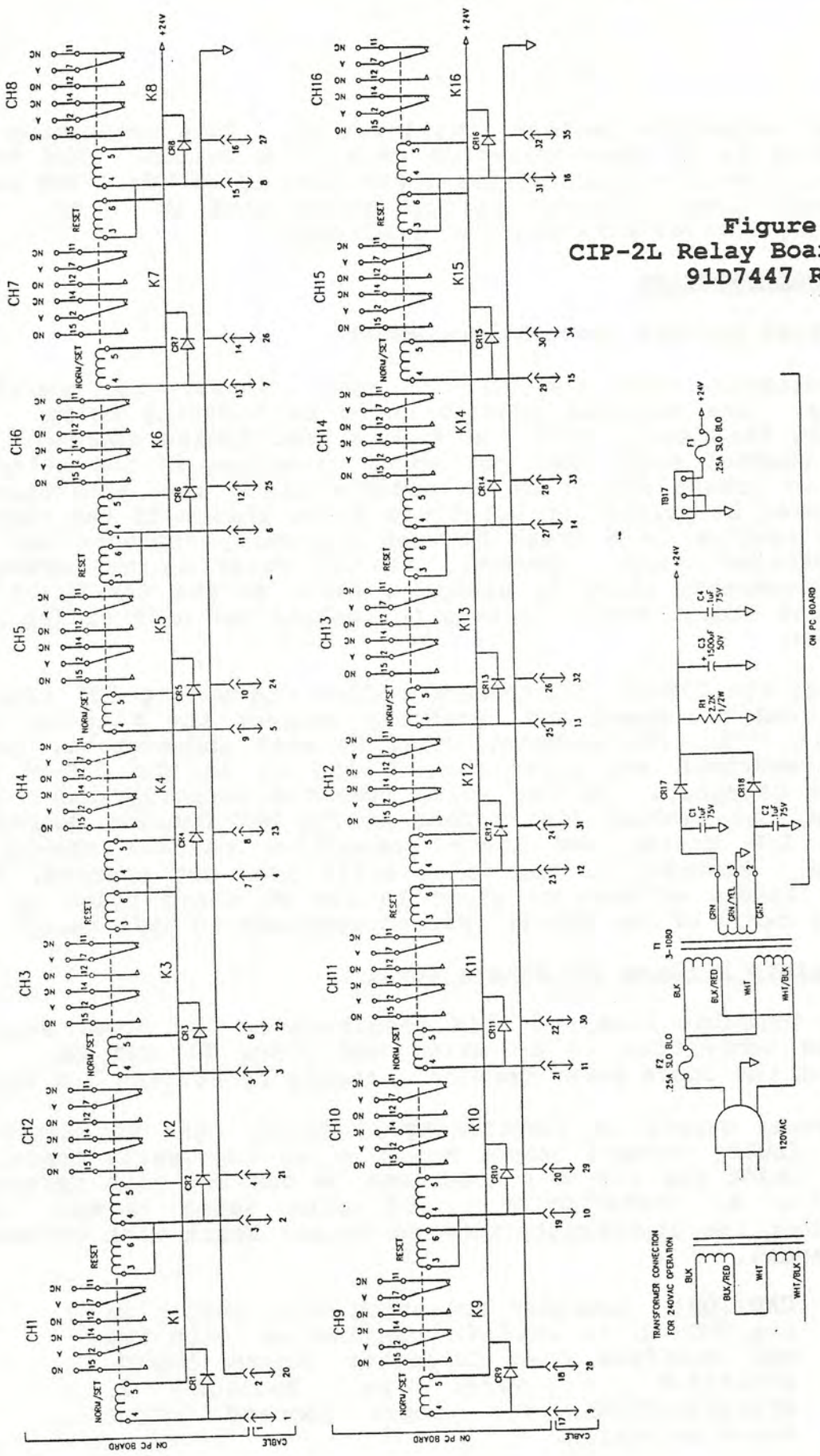

**Figure 2**  
**CIP-2L Relay Board Assembly**  
**20C3027 Rev A**

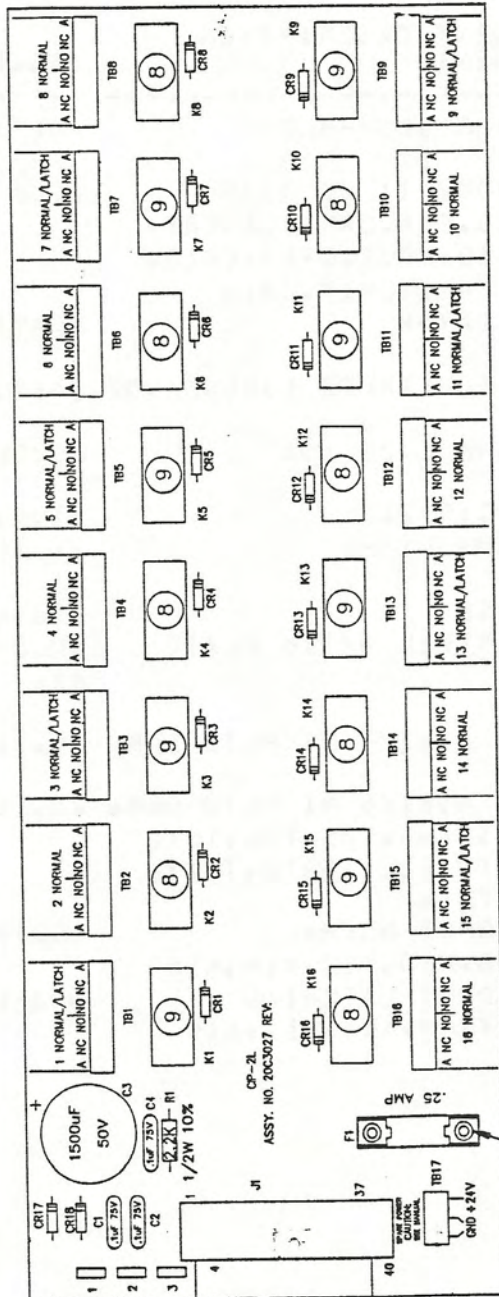



MOSELEY ASSOCIATES, INC.  
 111 CASTILIAN DRIVE  
 SANTA BARBARA, CA 93117-3093  
 (805) 968-9621

PAGE: 1

DATE: 9/19/88

PARENT ITEM: 9205857

DESCRIPTION: ASSY COMP CIP-2L  
 ENG. DRAWING NO.: 20C3027 A

REF NBR	COMPONENT ITEM NBR	COMPONENT DESCRIPTION & COMMENTS	ENG. DRAWING NO.	QUANTITY PER
	3370228	FUSE 1/4 AMP SLOW-BLO F1	MDL 1/4	1
	3610003	DIO 10D2 200V 1A SI D039 CR1,CR2,CR3,CR4,CR5,CR6,CR7, CR8,CR9,CR10,CR11,CR12,CR13, CR14,CR15,CR16,CR17,CR18	10U2	18
	4310215	CAP DISC .1/75V C1,C2,C4	UDA-104	3
	4350849	CAP PC MT ELECTRLTC 1500UF/50V C3	3427JJ152U050RM	1
	4420303	RES 2.2K OHM 1/2W 10% R1	RC206F222K	1
1	3474491	PCB RELAY CIP-2L	5106112	A 1
2	2250017	CA INTERCUNN CIP-2 J1	2481036	C 1
3	1210053	EYELET BRASS	6S3-4	2
4	337038+	CLIP FUSE STEEL W/TIN PLATE	6008-33AT	2
5	3290830	LUG GND 1,2,3	830	3
6	3291135	TERM STRIP 8181/3 NI PLTD SCRW TB17	25.102.0353S	1
7	3291200	TERM STRIP 8181/6 NI PLTD SCRW TB1, TB2, TB3, TB4, TB5, TB6, TB7, TB8, TB9, TB10, TB11, TB12, TB13, TB14, TB15, TB16	25.102.0653S	16
8	3250453	SKT RELAY DPDT NORMAL K2, K4, K6, K8, K10, K12, K14, K16	NC2-PS	8
9	3251089	SKT RELAY DPDT LATCHING K1, K3, K5, K7, K9, K11, K13, K15	NC2-LP2S	8

Figure 3  
 CIP-2L Assembly & Wiring Guide  
 21D2681 Rev H

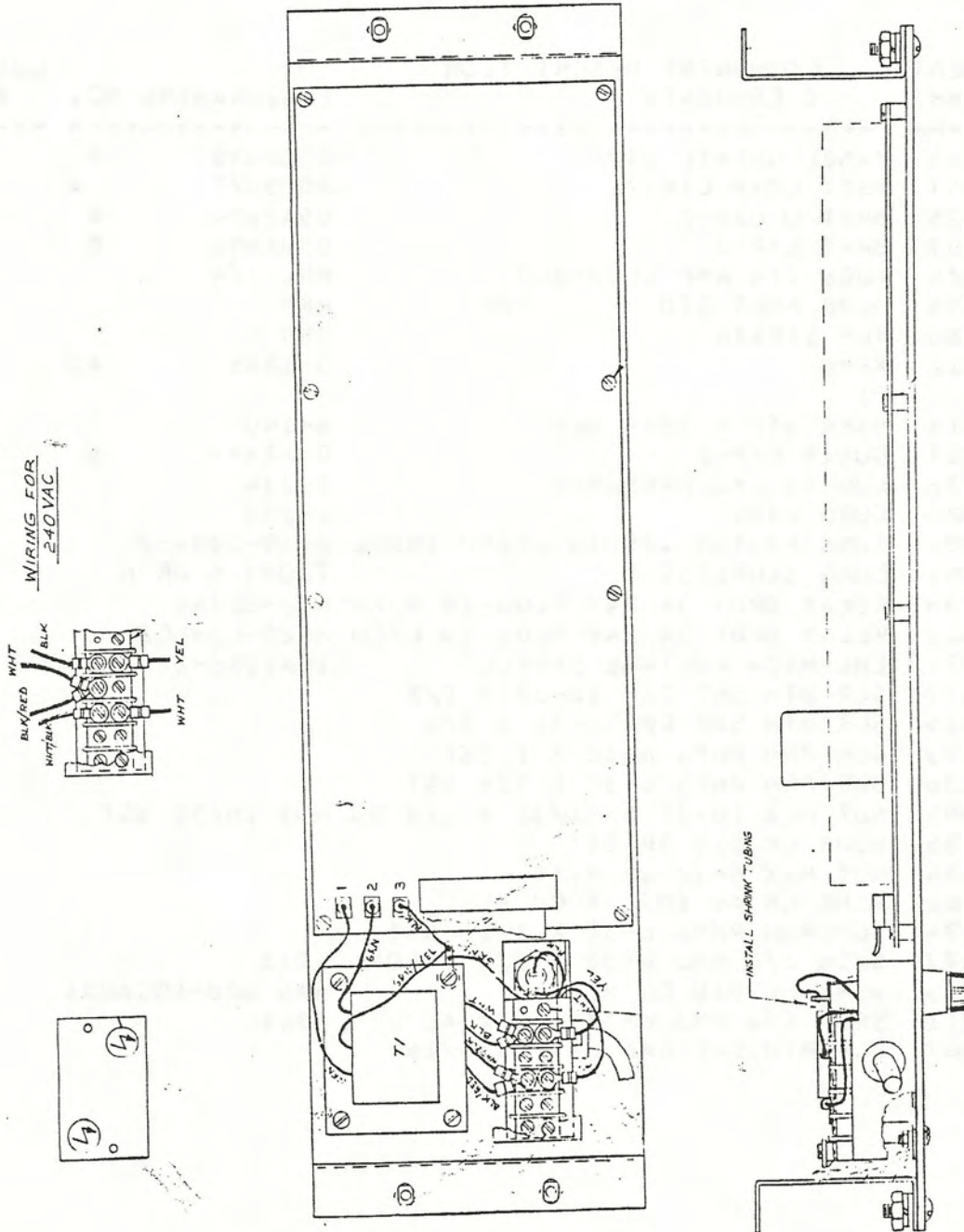



MUSELEY ASSOCIATES, INC.  
 111 CASTILIAN DRIVE  
 SANTA BARBARA, CA 93117-3093  
 (805) 968-9621

PAGE: 1

DATE: 9/19/88

PARENT ITEM: 9504600

DESCRIPTION: ASSY FINL CIP-2L (LATCHING)  
 ENG. DRAWING NO.: 21D2681-2 H

REF NBR	COMPONENT ITEM NBR	COMPONENT DESCRIPTION & COMMENTS	ENG. DRAWING NO.	QUANTITY PER
1	2010163	PANEL DETAIL CIP-2	05D2695	E
2	9205857	ASSY COMP CIP-2L	20C3027	A
3	2060325	BRKT U CIP-2	05A2694	F
4	2060507	BRKT CIP-2	05B2696	C
5	3370228	FUSE 1/4 AMP SLOW-BLD	MDL 1/4	
6	3370335	HLDR FUSE STD HKP	HKP	
7	1270180	RLF STRAIN	939	
8	4090312	XFMR T1	3-1086	AO
9	3290418	BARR STP 4 TERM BLK	4-140	
10	2060317	COVER CIP-2	05A2699	D
11	1090778	LUG #6 LKG PREFORMED	T-234	
12	3370020	CURR LINE	17239	
13	3110004	CUNN FASTON .250IN CRIMP INSUL	2-35-0804-2	
14	3110061	CUNN SLDRLSS	T2083 5 DR 6	
15	3270238	RELAY DPDT 3A 24V PLUG-IN NDRM	NC2-DC24V	
15	3270402	RELAY DPDT 3A 24V PLUG-IN LTCH	NC2D-L2-DC24V	
16	3430071	LBL HIGH VOLTAGE SYMBOL	10A1058-2	AO
17	1150077	SCR BTH SKT CAP 10-32 X 1/2		
18	1090315	SCR BTH SKT CAP 6-32 X 3/8		
19	1090273	SCR PNH PHPS 6-32 X 1 SST		
20	1090208	SCR PNH PHPS 6-32 X 3/8 SST		
21	1150093	NUT HEX 10-32 X 11/32 X 1/8 SS	NUT 10/32 SST	
22	1150135	WSHR LK #10 SR SST		
23	1090554	NUT HEX 6-32 SM PATT		
24	1090562	WSHR LK #6 INTL T CD PL		
25	1090174	SCR PNH PHPS 6-32 X 3/16 SST		
27	1230077	SPCR 1/4 RND 6-32 X 3/8 NYLON	4013	
28	1150143	WSHR FL #10 CD PL	NAS 620-10CAD#1	
29	1230911	SPCR 1/4 RND 6-32 X 1/2 AL	8343	
30	1090307	SCR BTH SKT CAP 6-32 X 5/16		



## CUSTOMER SERVICE INFORMATION

Moseley Associates, Inc. has a Technical Services Department to assist Moseley product users who experience difficulties. Our service is available at two levels: telephone consultation, and factory service. Different circumstances apply whether the product(s) are under Warranty/Service Agreement or are outside Warranty/Service Agreement status.

Please read the manual; a large portion of telephone calls to Moseley request information which is needed due to nonfamiliarity with the equipment. The majority of those questions are already answered by the Installation/Operation sections of each manual. If these do not help your problem, the first step in any factory service transaction should always be telephone consultation.

### Telephone Consultation

If telephone assistance is necessary, please have the following information available prior to calling the factory:

- A. Model Number and Serial Number of unit.
- B. Shipment date or date of purchase of an Extended Service Agreement.
- C. Suspected module identification markings.
- D. Be prepared to accurately describe the problems with the unit: Constant or intermittent? Precise symptoms? Meter readings? Operational frequency of unit?
- E. Factory test data, if applicable.

Once you are prepared with the above-requested information, contact our Technical Services Department for assistance. A Technical Services Representative who knows your product(s) is available during normal work hours (8:00 a.m. to 5:00 p.m., Pacific time, Monday thru Friday). Please have patience if the particular representative you should talk to is busy. Leave your name, call letters, equipment type and telephone number(s) where you can be reached in the next few hours. Someone will get back to you as soon as possible.



Please be prepared to keep telephone consultations as short as possible in order to free up the Technical Service Representative to help someone else in trouble. Usually the Technical Service Representative will make suggestions and recommendations for your next step. After trying these, you may call back if you continue to experience problems.

For telephone assistance call (805) 968-9621

#### After Hours Emergency (Only) Telephone Consultation

Emergency service is provided from 5:00 p.m. to 10:00 p.m., Pacific Time, Monday to Friday, and from 8:00 a.m. to 10:00 p.m., Pacific Time, on weekends and holidays. For telephone assistance call (805)968-9621.

This after hours service is for emergencies only. Please do not expect our representative to know the status of your order, to take parts orders or to be equipped to help with installation problems.

#### Factory Service

Arrangements for factory service can be made after consultation with the factory Technical Service Representative and his assignment to you of a Return Authorization (R.A.) Number. This number expedites your equipment's routing from the Receiving Department to Technical Services.

When returning your equipment to Moseley Associates, the following suggestions are offered to assist you. If you are returning a module, ensure that the module is packed sufficiently to withstand the rigors of the journey. Make sure the shipping carton is packed evenly and fully, with packing material filling all voids so that the module cannot shift inside the shipping carton. The package should also be marked in red with the words "Electronic Equipment" or "Fragile". Remember, the condition of the module is totally dependent on the care taken in the packing. Reference the return order number that you had previously obtained from the factory on the outside of the carton or on the shipping label. Make sure that the name of your company is listed on the shipping label, and insure your module appropriately.

If you are shipping a complete chassis, all modules should be tied down as they were originally received. On some Moseley Associates equipment, shipping screws are required on the underside or topside of the chassis. In this case, printing on the chassis will indicate where such screws should be installed and secured.



Include any and all descriptions of the difficulties encountered with your equipment in the field. This will greatly assist us in processing your equipment and returning it as expeditiously as possible.

Use the original shipping carton in which your equipment was supplied if possible. Ensure that the carton is packed evenly and fully, with packing material filling any voids so that the chassis cannot shift inside the carton. Make sure the carton is sealed properly with either nylon-reinforced tape or shipping sealing tape. Mark the outside of the carton "Electronic Equipment - Fragile" in big, red letters. This will assist the survival of the equipment in the shipping process. Again, bear in mind that the survival of the unit depends almost solely on the preparation taken in shipping it.

When returning your equipment to our factory, please address it to the following:

**MOSELEY ASSOCIATES, INC.**  
**Attn: Technical Services Department**  
**111 Castilian Drive**  
**Santa Barbara, CA 93117-3093**

Display your return order number clearly on the shipping label, and insure the equipment for the appropriate amount.

All equipment must be shipped prepaid; Moseley Associates, Inc. will return the equipment prepaid under Warranty and Service Agreement conditions, and either freight collect or billed for equipment not covered by Warranty or a Service Agreement.

#### **GENERAL**

#### **Replacement Modules**

Moseley Associates encourages the purchase of recommended spare parts kits to allow the customer to be totally self sufficient with regard to parts. We recognize that there are extenuating circumstances when troubleshooting to the component level is neither practical nor possible. If this is the case, replacement module exchange may be the most expedient way of correcting the problem. Each product manual lists recommended spares.



Non-frequency sensitive replacement modules are normally available for immediate shipment. If you require a replacement module from Moseley Associates, please give your shipping address to our Technical Services Engineer. If the module or equipment to be supplied to your company is to be held at the airport with a telephone number to call, provide at least two telephone numbers. This will often expedite the delivery or pickup of the replacement module or equipment.

### Field Repair

Always try to isolate the problem to a specific area or module, if possible. By comparing actual wave shapes and levels with those referenced on the block and level diagrams or schematics, the problem often can be localized to the component level.

If an integrated circuit is suspect, carefully remove the original and install the new one in the same direction. These devices are installed one way only. Installing a new device backward may damage the newly-installed component or the surrounding circuitry. ICs occasionally exhibit temperature-sensitive characteristics. If a suspicious device operates intermittently, or appears to drift, Freeze Mist may aid in diagnosing the problem.

If a soldered component has to be removed from a printed circuit board, do the following:

Use a 40 W soldering iron with a 1/8-inch tip. Do not use a soldering gun. Excessive heat may cause damage.

Remove all solder contacting the lead or leads from the component and from the associated printed circuit pad. To assist in the removal of the solder, solder-sipping braid such as solder wick is very useful. Once the solder has been removed, remove the component from the board.

When installing the new component, prebend the leads of the replacement component so they will easily fit into the appropriate PC board holes. Solder each lead of the component to the bottom side of the board with a 40 W soldering iron with a 1/8-inch tip. Always use a good brand of rosin-core solder. The solder joint should be smooth and shiny. Also, be sure that excessive heat is not used in this soldering operation. Excessive heat will damage the printed circuit pad that comes in contact with the new component. Finally, cut each lead of the replacement component close to the solder on the pad side of the printed circuit board with a pair of diagonal cutters. Then remove all residual flux with either flux cleaner or a cotton swab moistened with flux cleaner.