

INSTRUCTIONS

DA504 AUDIO DISTRIBUTION SYSTEM

If You Didn't Get This From My Site, Then It Was Stolen From

www.SteamPoweredRadio.Com



INDEX.

<u>Section.</u>	<u>Subject.</u>	<u>Page.</u>
1	General Description	3
2	Specifications	5
3	Installation	6
4	Maintenance	9

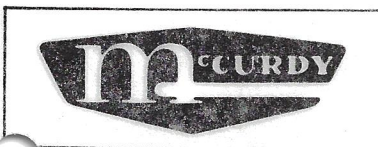

McCURDY RADIO INDUSTRIES LIMITED

108 CARNFORTH ROAD, TORONTO, ONTARIO M4A 2L4 (416) 751-6262, TELEX 06-9635.

McCURDY RADIO INDUSTRIES INCORPORATED

1051 CLINTON STREET, BUFFALO, N.Y. 14206 (716) 854-6700

LIST OF ILLUSTRATIONS.

<u>Figure.</u>	<u>Title.</u>	<u>Page.</u>
1-1	Block Diagram	4
3-1	Frame Layout	7
3-2	Frame Wiring	8
3-3	AT310 Connector Wiring	8

SUB ASSEMBLY INSTRUCTIONS.

AT310	Audio Distribution Amplifier
RG311	Remote Gain Distribution Amplifier, Optional
RG312	Remote Gain Distribution Amplifier, Optional
PS855	Power Supply

Section 1. GENERAL DESCRIPTION.

- 1.01 The DA504 Audio Distribution System is designed for audio distribution in broadcasting or other commercial applications where professional quality must be maintained. The DA504 consists of an FR906 19-inch equipment Frame holding up to six AT310 Distribution Amplifiers and one PS855 Power Supply.
- 1.02 Each AT310 bridges one input at any specified level from -12dBm to +20dBm and provides up to 22 isolated outputs at +8dBm, 600 ohms, balanced. Twelve of these outputs are provided within the amplifiers and provision is made for the addition of up to ten external outputs. Thus, a complete complement of six amplifiers can provide 132 outputs from six inputs, 72 internal and 60 external. See AT310 instructions for further information.
- 1.03 A preset gain control is provided on the front panel of each AT310 distribution amplifier. This control will vary the gain from 0 up to the maximum available.
- 1.04 Each AT310 is also equipped with a summing input, allowing it to be used with switchers, or other systems, having the insulation networks built in.
- 1.05 An RG311 or RG312 remote gain distribution amplifier is available in place of the AT310. These amplifiers provide for remote DC control of amplifier gain. The remote gain sections of these amplifiers are also available separately, allowing field conversion of AT310 amplifiers to remote gain at any time. See AT310 instructions for further information.
- 1.06 The FR906 equipment Frame mounts in a standard 19 inch rack or pedestal and occupies only 5.25 inches of vertical space.

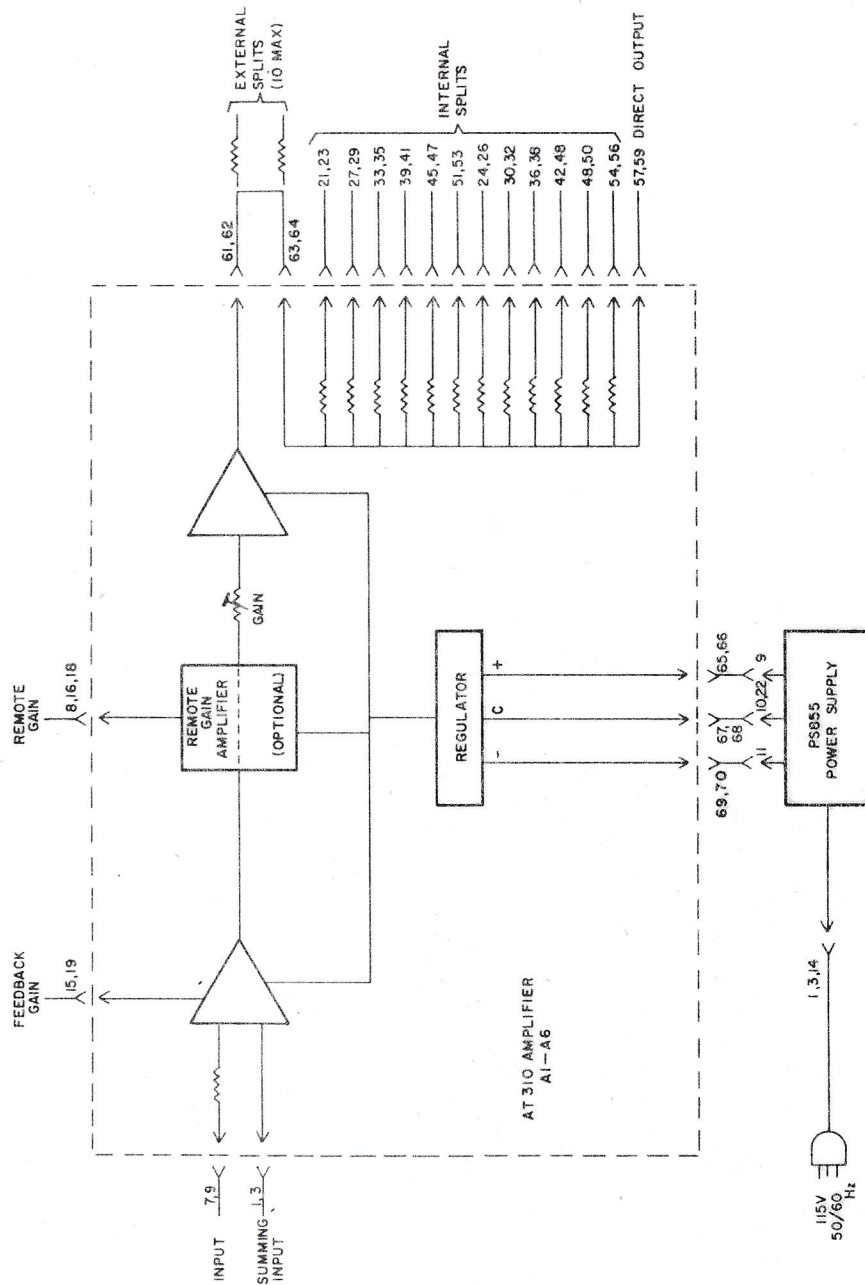

Figure 1-1. Block Diagram

Section 2. SPECIFICATIONS.

- 2.01 Frequency Response:
±0.25dB, 20Hz to 20kHz (Reference 1 kHz).
- 2.02 Input Level:
-12dBm to +20dBm, maximum.
- 2.03 Gain:
Variable from 0 to 20dB by means of preset control. Maximum gain of 40dB with 820 ohm feedback resistor.
- 2.04 Output Splits:
Maximum 22 per amplifier. Twelve provided, up to 10 external possible.
- 2.05 Output Level:
+8dBm, +25dBm maximum.
- 2.06 Source Impedance:
600 ohms balanced.
- 2.07 Input Impedance:
20k ohms or summing, balanced.
- 2.08 Output Impedance:
600 ohms, balanced.
- 2.09 Load Impedance:
600 ohms, balanced, minimum.
- 2.10 Noise:
90dB below +18dBm output, from 10Hz to 100kHz, depending on gain setting.
- 2.11 Distortion:
Less than 0.2%, 20Hz to 20kHz at +18dBm out.
Less than 0.25%, 20Hz to 20kHz at +25dBm out.
- 2.12 Output Split isolation:
Better than 70dB, 20Hz to 20kHz (80dB typical mid-band).
- 2.13 Power Requirement:
115V, 50/60Hz, approximately 120VA (230V available).
- 2.14 Dimensions:
5.25 in. (13.34 cm) High, 13 in. (33 cm) Deep, 19 in. (48.26 cm) Wide.
- 2.15 Weight:
Approximately 30 pounds, (13.6 kg).

Section 3 INSTALLATION.

- 3.01 On receipt of the equipment, examine each unit for any damage that may have occurred in transit. If any damage is found, report it in accordance with the enclosed Damage Claim Procedure Form.
- 3.02 Under some shipping conditions, the power supply and amplifier modules will be removed from the frame and packed separately. Install these after all other installation is complete.
- 3.03 Mounting.
The DA504 occupies 5-1/4" of vertical space in a standard 19" rack. The unit generates very little heat and so the frame may be stacked as required. However, avoid proximity to equipment that generates considerable heat. Further, the DA504 should be mounted at least 3 1/2" above or below power supplies or transformers in order to avoid hum pick-up.
- 3.04 Installation Connections.
Refer to figures 3-2 and 3-3 for terminal numbers.
- 3.05 Audio Wiring.
Audio runs should consist of shielded, twisted pairs such as MRI SA12002. Keep input and output audio runs well separated from each other and from ac power wiring. Audio wiring should be dressed neatly and arranged in harnesses by function and level (input wiring, output wiring etc.). Do not lace together pairs of more than 28dB difference in level.
- 3.06 Input Wiring.
Input wiring should enter at the top right of the frame as viewed from the rear. Input wires are to be soldered directly to the AT310 connector terminals located on the rear panel. Wire the shield to pin 5.
NOTES. (1) To maintain proper phasing between inputs and outputs where this is important, phasing is shown on Figure 3-3.
(2) Shields should be grounded at the designated terminals on the DA504, provided they are not grounded at the far end. Do not ground shields at both ends of a run.
- 3.07 Output Wiring.
Outputs are wired directly to the terminals on the AT310 connector as shown in figures 3-2 and 3-3. Cables should exit from the bottom right of the frame as viewed from the rear. The output shields should be wired to the common bus running through pins 67 and 68 of the connector. Alternately, the output shields can be wired to the terminals designated with an asterisk on Figure 3-3. If this is done, these terminals must be connected to the common bus. Unused outputs should be left unterminated.

- 3.08 If additional, external, output splits are required, these are wired to pins 57 and 59 on amplifier connector. The "positive" phase should be connected to pin 57 and the "negative" phase to pin 59. The resistors used for the external splits should be 300 ohm, 1/4W, ±5% carbon film types.
- 3.09 Grounding.
Run a No. 16 stranded, insulated wire from the ground (common) bus on the terminal strip to system ground (Figure 3-2).
- 3.10 Ac Power.
 - (a) The DA504 ac power cord plugs into a 115 volt, 50/60Hz ac source. Keep this cord separated from the audio leads.
 - (b) The DA504 may be operated from a 230 volt 50/60Hz ac source if the power transformer strapping is changed. See PS855 power supply instructions.
- 3.11 If the above wiring recommendations are followed the system should meet all the performance specifications of Section 2.
- 3.12 Installing Modules in Frame.
Install the amplifiers and power supply into the DA504 frame in accordance with the layout of Figure 3-1. Be careful not to damage the PC boards or connectors.
- 3.13 Final Level Adjustment.
After installation, refer to the AT310 instructions and set up the gains of the amplifiers as directed.

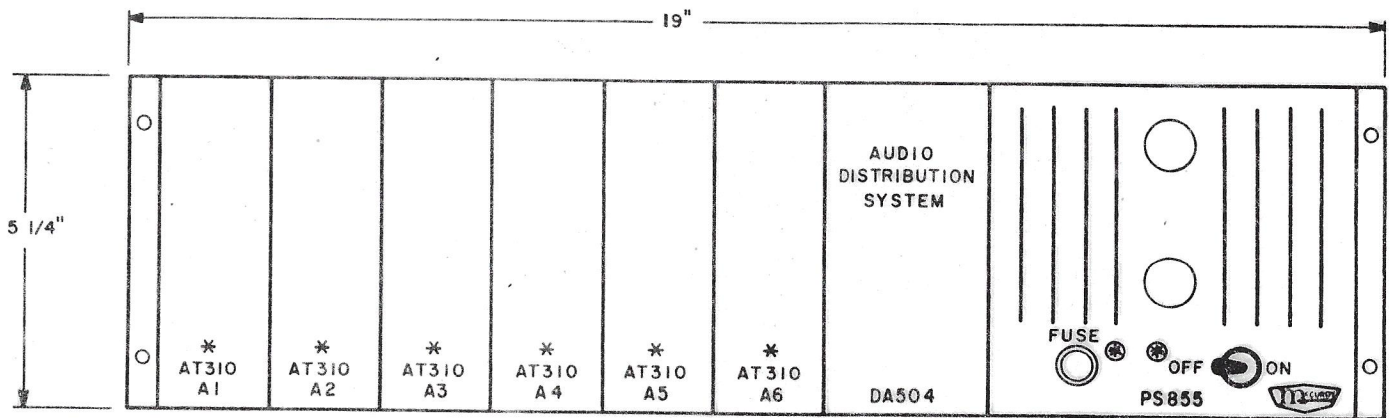

FRAME FRONT VIEW

* UP TO SIX AMPLIFIERS INSTALLED AS PER CUSTOMER REQUEST.

Figure 3-1. Frame Layout

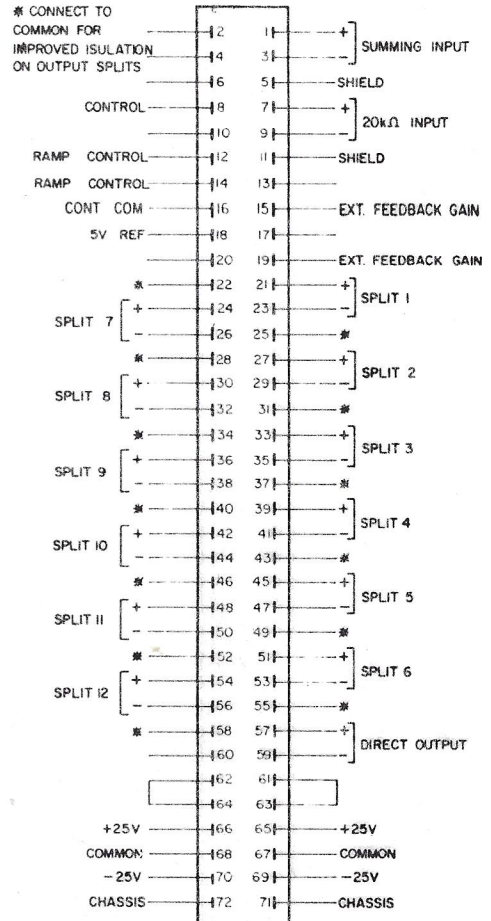
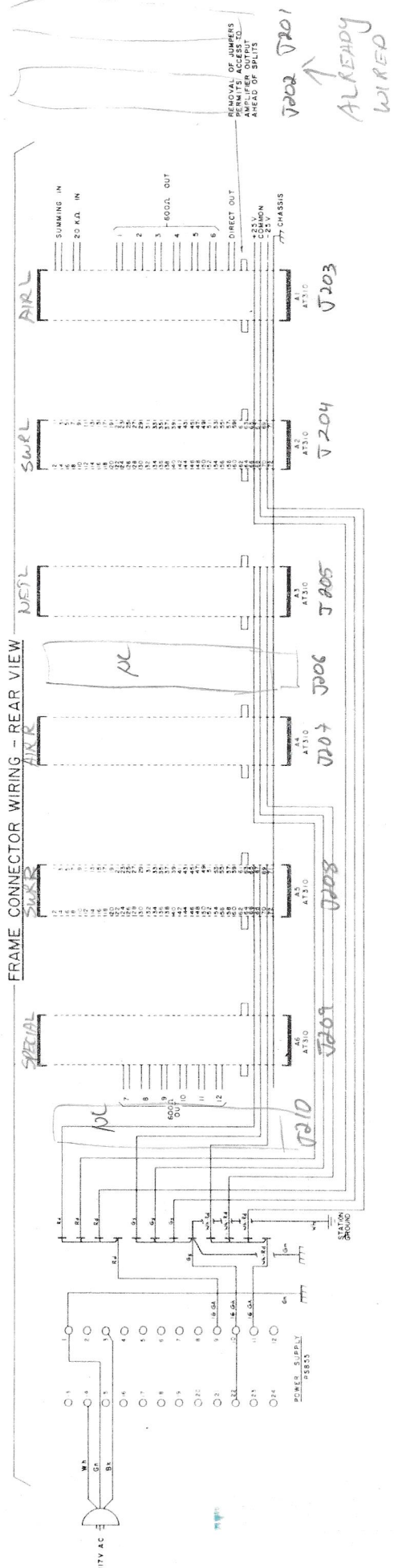

VIEWED FROM WIRING SIDE, REAR OF CONNECTOR

Figure 3-3. AT310 Connector Wiring

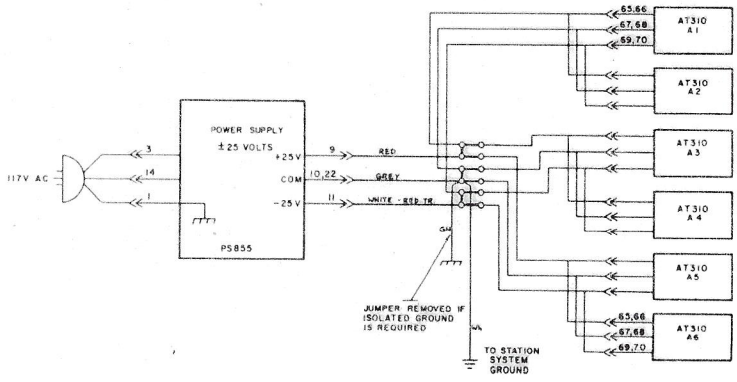

Figure 3-2. Frame Wiring

Section 4 MAINTENANCE.

4.01 The DA504 should be inspected during regular maintenance periods. Remove accumulated dust by means of a soft non-metallic brush or a vacuum cleaner.

WARNING. ALWAYS SHUT OFF THE AC POWER WHEN WORKING ON THE EQUIPMENT. DO NOT REMOVE OR REPLACE MODULES WHEN POWER IS APPLIED TO THE EQUIPMENT.

4.02 The amplifier and power supply modules may be removed and bench-tested separately if a fault is suspected. Refer to the separate instructions for these units.

Table 4.01. Parts List.

Reference Designation .	Supplier and Part No.	Description.
A1 to A6	McCurdy AT310	Distribution Amplifier
PS1	McCurdy PS855	Power Supply
J1 to J6	EDAC 345-072-500-808	Connector:receptacle; 72-30 female contracts.
J7	Amphenol 26-190-16	Connector: receptacle; 16 female contacts.
—	Cords of Canada 3/18	Cable & Plug Assembly ac power.

INSTRUCTIONS AT310 DISTRIBUTION AMPLIFIER

INDEX

<u>Section</u>	<u>Subject</u>	<u>Page</u>
1	General Description	2
2	Specifications	3
3	Installation	4
4	Circuit Description	7
5	Maintenance	10
6	Parts List	15

LIST OF ILLUSTRATIONS & DRAWINGS

<u>Number</u>	<u>Title</u>	<u>Page</u>
Figure 3-1	Connector Wiring	6
Figure 3-2	Feedback Resistor/Gain Table	6
Dwg. B-310/2-3	Block Diagram	8
Dwg. D-310/2-1	Schematic Diagram, AT310 & AT310-30	9
Dwg. C-310/8-1	Component Layout, AT310	12
Dwg. C310-30/8-1	Component Layout, AT310-30	13
Dwg. B-310/1-2	Test Setup	14

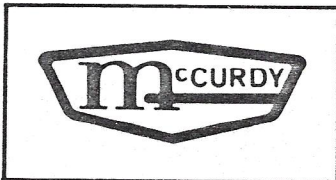

McCurdY RADIO INDUSTRIES LIMITED

108 CARNFORTH ROAD, TORONTO, ONTARIO M4A 2L4
(416) 751-6262, TELEX 06-963533, TWX 610-492-1373

McCurdY RADIO INDUSTRIES INC.

1711 CARMEN DRIVE, ELK GROVE VILLAGE, ILLINOIS 60007,
(312) 640-7077, TWX 910-222-0436

www.SteamPoweredRadio.Com

McCurdy Radio Industries reserves the right, without notice to make such changes in equipment, design, specifications, or components as progress in engineering or manufacturing techniques may warrant to improve the performance of the product.

Section 1 GENERAL DESCRIPTION.

- 1.01 The AT310 is a high quality audio distribution amplifier providing up to 22 isolated outputs at +8dBm, 600 ohms, balanced, from one input. The input circuit permits bridging of input levels from -12dBm to +20dBm, thereby covering most requirements in broadcast and similar professional applications for distribution amplifiers.
- 1.02 Twelve of the possible 22 outputs are provided within the amplifier and provision is made for the addition of up to ten external outputs.
- 1.03 The AT310 is also equipped with a summing input, allowing it to be used with switchers, or other systems, having the isolation networks built in.
- 1.04 A preset gain control is provided on the front panel of each AT310 distribution amplifier. This control will vary the gain from 0 up to the maximum available.
- 1.05 Provision is made on the AT310 for installation of an RG310-1 or RG310-2 remote gain control. Installation of either of these units allows remote DC control of amplifier gain. See Section 3 for installation instructions.
- 1.06 All circuitry is silicon solid state and is assembled onto a glass-epoxy printed circuit board fastened to a metal stiffener plate. The complete assembly plugs into an FR906 19-inch equipment frame, the DA504 Audio Distribution Assembly or an individual 72-pin edge connector.
- 1.07 The AT310 is used mainly in the DA504 Audio Distribution Assembly, but may be used in other applications where a high-quality distribution amplifier is required.
- 1.08 The AT310-30 is identical to the AT310 with the exception that it is designed to be used with 30K ohm input bridging resistors.

Section 2 SPECIFICATIONS.

- 2.01 Frequency Response:
±0.25dB, 20Hz to 20kHz (Reference 1kHz).
- 2.02 Input Level:
-12dBm to +20dBm, maximum.
- 2.03 Gain:
Variable from 0 to 20dB by means of preset control. Maximum gain of 40dB with 820 ohm feedback resistor.
- 2.04 Output Splits:
Maximum 22. Twelve provided on amplifier, up to 10 external.
- 2.05 Output Level:
+8dBm, +25dBm maximum.
- 2.06 Source Impedance:
600 ohm balanced.
- 2.07 Input Impedance:
20K ohms or summing, balanced.
- 2.08 Output Impedance:
600 ohms, balanced.
- 2.09 Load Impedance:
600 ohms, balanced minimum.
- 2.10 Noise:
(10Hz to 100kHz) 90dB below +18dBm output, at unity gain. Noise figure depends on gain setting.
- 2.11 Distortion:
Less than 0.2%, 20Hz to 20kHz at +18dBm out.
Less than 0.25%, 20Hz to 20kHz at +25dBm out.
- 2.12 Output Split Isolation:
Better than 70dB, 20Hz to 20kHz (80dB typical, mid-band).
- 2.13 Power Requirements:
±25V DC, 600mA maximum.
- 2.14: Dimensions:
1-3/4" (44.5mm) wide, 4 1/2" (112mm) high, 10" (255mm) deep.

Section 3 INSTALLATION.

- 3.01 On receipt of the AT310 distribution amplifier, examine it for any damage that may have occurred in transit. If any damage is found report it in accordance with the enclosed damage claim procedure form.
- 3.02 The AT310 plugs into the FR906 equipment frame which occupies 5-1/4" of vertical space in a 19" rack. The amplifier generates very little heat, therefore, the frames may be stacked as required. However, avoid proximity to other equipment that generates considerable heat or to power transformers, which may cause hum pickup.
- 3.03 When the AT310 is not to be mounted in the FR906 equipment frame, a 72-pin edge connector (EDAC 345-072-500-808 or equivalent) will be required to mate with the PC board. All connections to the amplifier are made to this edge connector, either mounted in an FR906 frame or mounted separately.
- 3.04 Refer to Figure 3-1 for detailed terminal numbers.
- 3.05 Power Wiring:
If the amplifiers are in a system frame being fed from a common power supply, all +25V terminals (pins 65 & 66) may be bussed together, all -25V terminals (pins 69 & 70) may be bussed together, all common terminals (pins 67 & 68) may be bussed together, and all chassis terminals (pins 71 & 72) may be bussed together.
- 3.06 A 16 gauge, stranded, insulated wire should be run from the common bus on the AT310 connector to system ground.
- 3.07 The chassis terminal or the AT310 connector should be connected to the frame, or associated chassis by a short, 20 gauge solid wire.
- 3.08 Audio Wiring:
Audio runs should consist of shielded, twisted pairs, such as MRI SA12002. Keep input and output audio runs well separated from each other and from AC power wiring. Audio wiring should be dressed neatly and arranged in harnesses by function and level (input wiring, output wiring, etc.). Do not lace together pairs of more than 28dB difference in level.

- 3.09 Where it is important that the outputs be in phase with the input, the correct phasing is indicated on Figure 3-1 by a +, which indicates the "high" side of the line.
- 3.10 Ground the audio shields only at one end of the run, preferably at the AT310 connector. The input shield should be connected to pin 5 and the outputs shields to the ground bus, pins 67 & 68. Alternately, the output shields can be wired to the terminals designated with an asterisk on Figure 3-1. If this is done, these terminals must be connected to the common, ground, bus.
- 3.11 When more than twelve outputs are required, up to ten additional, external outputs may be wired to the direct output. A 300 ohm, $\frac{1}{4}$ Watt, $\pm 5\%$ isolating resistor should be used in each side of each output. Refer to Figure 3-1 for the proper pin numbers and phasing
- 3.12 In all normal applications, connector pins 61 & 63 are connected together and pins 62 & 64 are connected together.
- 3.13 All unused outputs may be left unterminated.
- 3.14 If the above wiring recommendations are followed, the system should meet all the performance specifications given in Section 2.
- 3.15 Final level adjustment:
After the amplifier is installed, the gain should be adjusted to the level required by means of the preset gain control on the front of the guide plate. As supplied, the AT310 has a maximum gain of 20dB. A feedback resistor may be used to obtain a maximum gain of 40dB. See Figure 3-2 for selection of the proper feedback resistor.
- 3.16 A preset gain control, R20A, is provided in series with the main gain control, R20. This control may be used to set the gain of the amplifier, thus preventing accidental cutting of amplifier gain with the front panel control. When the gain is adjusted with the preset control, R20A, the front panel control R20, can only decrease the gain by a predetermined amount.
- 3.17 Installation of Remote Gain Amplifiers RG310-1 or RG310-2.
Refer to Dwg. D-310/2-1 and to Remote Gain Amplifier Instructions for identification of points mentioned in the following procedure.
- (a) Remove AT310 from guide plate by removing four, 4-40 machine screws.
 - (b) Remove Integrated circuit IC3 from socket and resistor R19 from PC board.
 - (c) Make sure holes in PC board numbered 1 to 9 are open (free of solder).
 - (d) Make sure the nine bare wire leads on the Remote Gain Amplifiers are straight and install spacers (supplied with Remote Gain Amplifier) at points A3, 8, and 9.
 - (e) Install Remote Gain Amplifier on AT310 board, so that all leads are

- 3.17 (e) straight, solder connections and clip off excess leads.
 - (f) Install shielded cables 'C' and 'E', Dwg. C-310/8-1. These cables are supplied with the remote gain amplifier.
 - (g) Refer to Remote Gain Amplifier instructions for specifications and other data.
- 3.18 The AT310-30 is installed the same as the AT310 except that the audio input must be connected to pins 1 and 3 through external 30K ohm bridging resistors.

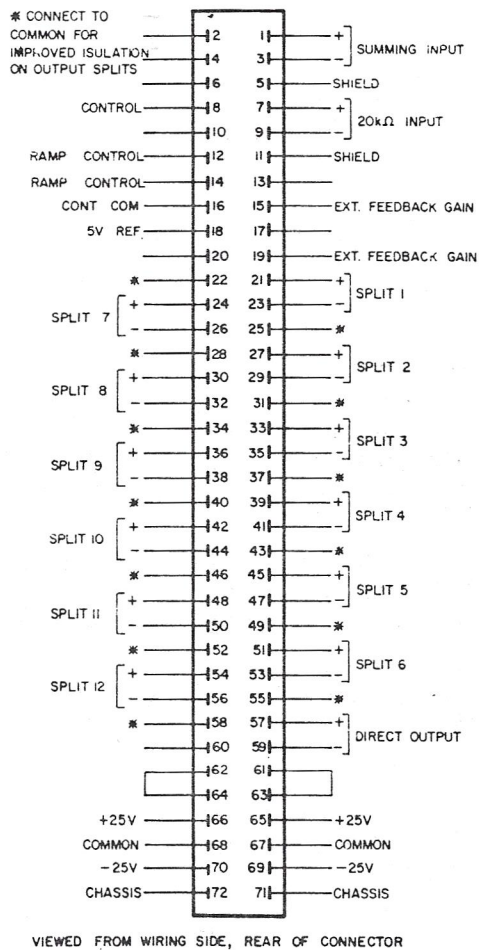

Figure 3-1 Connector Wiring

AMPLIFIER GAIN	RESISTOR VALUE
20dB	OPEN
25dB	12k ohm
30dB	4300 ohm
35dB	1800 ohm
40dB	820 ohm

Figure 3-2. Feedback Resistor/Gaintable

Section 4 CIRCUIT DESCRIPTION.

- 4.01 The circuitry of the AT310 is shown on Dwg. D-310/2-1, and in simplified form, on Dwg. B-310/2-3.
- 4.02 The power supply section of the AT310 provides an accurately regulated and filtered $\pm 15V$ DC for the input stages and optional remote gain amplifier from an input of $\pm 25V$ DC. Integrated circuit regulators IC4 and IC5 are used for this function.
- 4.03 Power for the output stage, Q24-Q27, is taken directly from the $\pm 25V$ DC input. An RC filter is used to provide power to the driver section of the output amplifier.
- 4.04 The input amplifier, consisting of IC1, IC2 and IC3, provides a balanced, summing input and an unbalanced output to level control R20. Two inputs are provided, one with built-in 10k ohm bridging resistors and the other direct, without resistors, for use in applications with external resistors (switcher crosspoints, etc.).
- 4.05 When the optional Remote Gain Amplifier is installed, IC3 and R19 are not used. The remote gain module provides the connections between IC1, IC2 and the level control.
- 4.06 An amplifier, consisting of Q1-Q3, providing external feedback gain control follows the gain control, R20. The external feedback resistor, connected between pins 15 and 19 on the edge connector, shunts the internal resistor R25, which decreases the amount of feedback applied around the amplifier, therefore, increasing the gain
- 4.07 The direct-coupled, complimentary-symmetry output amplifier, consisting of Q4-Q27 and associated components, follows the feedback gain amplifier stage and provides the power amplification necessary to drive the output.
- 4.08 The amplifier output is coupled directly to the edge connector before being fed to the output splits to allow for the insertion of an output transformer or other special circuitry.
- 4.09 Twelve balanced 600 ohm output splits are supplied on the amplifier, along with one direct output. Up to ten external 600 ohm outputs may be wired to the direct output.

DO NOT SCALE

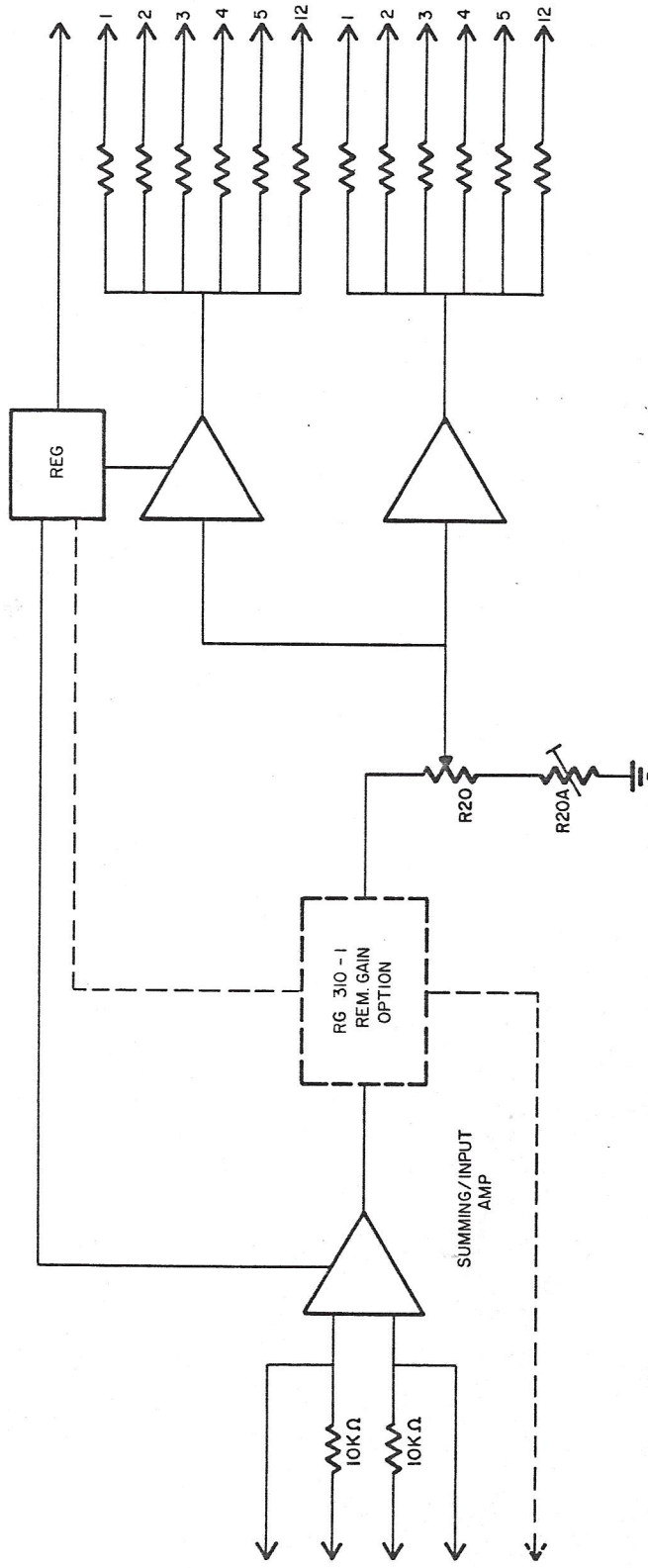

NOTE: AT310 WITH RG310-1 BECOMES RG311.

www.SteamPoweredRadio.Com

ISSUE		R20A ADDED VW JUNE 23/76		UPDATED, NOTE ADDED FOR CLARITY - KV AUG 27/79	
		2	2		
MCCURDY RADIO INDUSTRIES LIMITED TORONTO - ONTARIO		AT310		DISTRIBUTION AMPLIFIER SCHEMATIC	
DRAWN- VW		APPROVED- <i>[Signature]</i>		SCALE-	
CHECKED-		DESIGN-		DATE- FEB 10/75	
TOLERANCES UNLESS OTHERWISE SPECIFIED		DECIMAL ± .005		ALL DIMENSIONS IN INCHES DO NOT SCALE	
MATERIAL-		FRACTIONAL ± 1/64			
FINISH-		ANGULAR ± 1/4°		UNIT- B 310/2-3	
				DRAWING NO.	

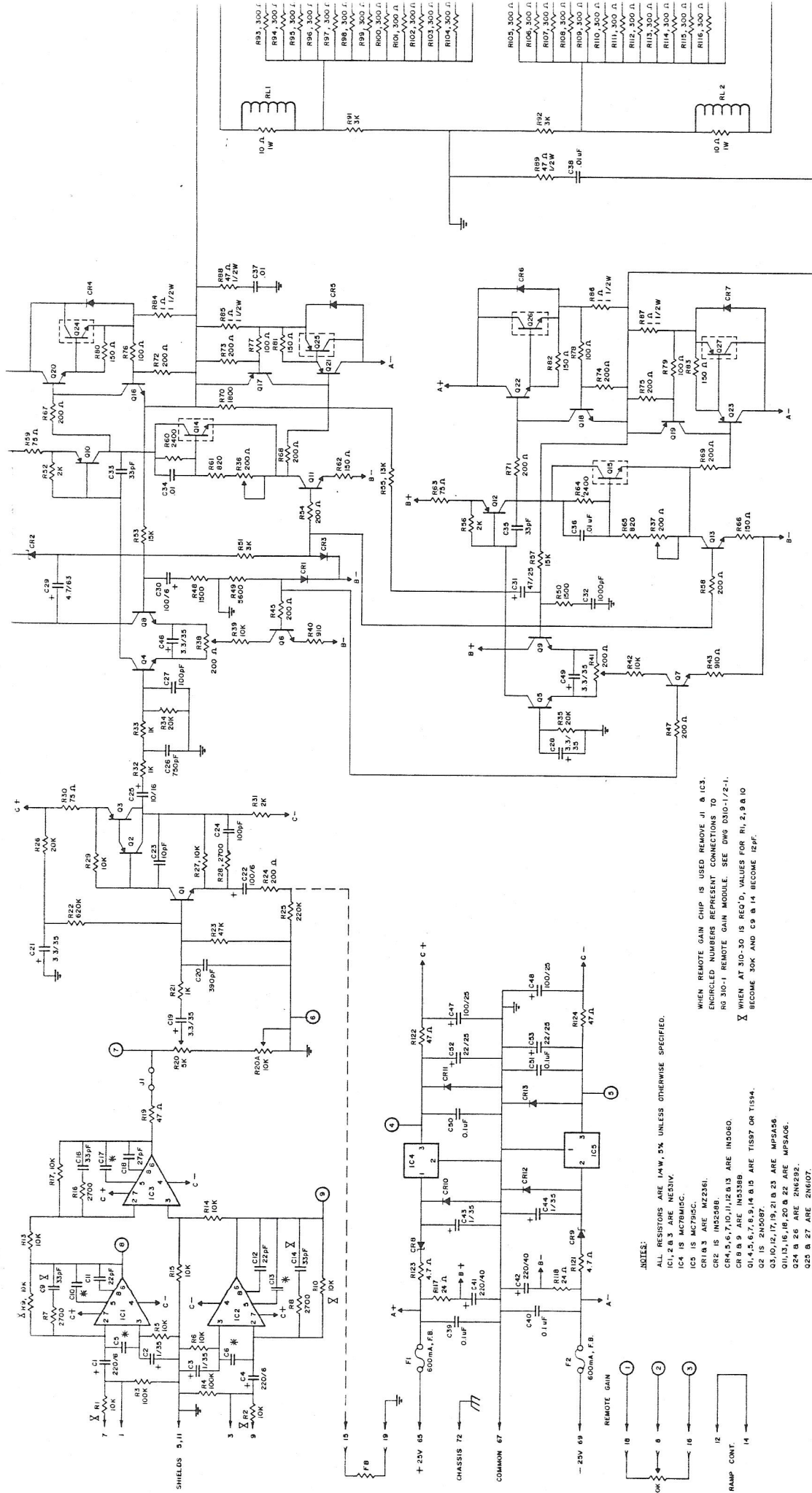

RESISTORS ARE 1/4W, 5% UNLESS OTHERWISE SPECIFIED.
 IC1 IS MC7915C.
 IC2 IS MC7915C.
 IC3 IS MC7915C.
 IC4 IS MC7915C.
 CR1 & 3 ARE MZ2361.
 CR2 IS IN5228B.
 CR3, 5, 6, 7, 10, 11, 12, 13 ARE IN4000.
 CR4, 8, 9 ARE IN4338B.
 CR14, 15, 16, 17, 19, 21, 23 ARE 1N5408.
 CR18, 19, 20, 22 ARE 1N5408.
 CR24, 26 ARE 2N6292.
 CR25, 27 ARE 2N6107.
 * OPTIONAL

WHEN REMOTE GAIN CHIP IS USED REMOVE J1 & IC3.
 ENCIRCLED NUMBERS REPRESENT CONNECTIONS TO
 RO 310-1 REMOTE GAIN MODULE. SEE DWG 0310-1/2-1.
 X WHEN AT 310-30 IS REQ'D, VALUES FOR R1, 2, 9 & 10
 BECOME 30K AND C9 & 14 BECOME 15PF.

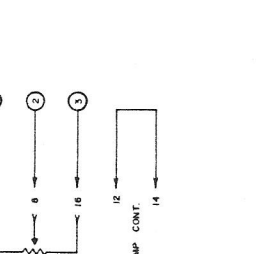

MCCORDY RADIO INDUST.

AT 310

DISTRIBUTION AMPLIFIER SCHEMATIC

JUNE 5 / 80

MJE

ALL DIMENSIONS IN INCHES
DO NOT SCALE

D-310/2-1

www.SteamPoweredRadio.Com

REWORK AT 310 & ISSUE

DAS SEPT 3/80 12

DAS JUN 5/80 11

DAS JUN 5/80 11

AT 310-30 COMBINED

Section 5 MAINTENANCE

- 5.01 The AT310 should be inspected for damaged or deteriorated components and wiring during regular maintenance periods. Remove accumulated dust by means of a soft non-metallic brush or vacuum cleaner.
- 5.02 When removing or replacing components, be careful not to damage the printed circuit board, wiring or other components. Use a 25-Watt fine-point, temperature-controlled soldering iron and resin-core solder only. Refer to Dwg. D-310/2-1 for the component layout of the AT310 and AT310-30 distribution amplifiers.
- 5.03 The following test procedures check that the AT310 is functioning properly and provide a means for setting up the unit for initial operation.
- 5.04 The test equipment should be of the type specified, or equivalent, and set up as shown on Dwg. B-310/1-2.
- Audio Generator: Amalgamated Wireless G231.
 - Distortion Analyzer: Hewlett-Packard HP334A.
 - Oscilloscope: Hewlett-Packard HP1200B.
 - Electronic Voltmeter: Fluke 8000A.
 - Isolation Transformer: Hewlett-Packard HP11005A.
 - Edge Connector: EDAC 345-072-500-808.
 - 620 ohm, $\frac{1}{2}$ W, $\pm 5\%$ resistor.
 - 620 ohm, $\frac{1}{4}$ W, $\pm 5\%$ resistor.
 - 820 ohm, $\frac{1}{4}$ W, $\pm 5\%$ resistor.
- 5.05 A well filtered, regulated, power supply capable of delivering ± 25 volts DC at 600mA, maximum should be used. A McCurdy PS855 is recommended.
- 5.06 DC Adjustments:
For the DC adjustments, the test equipment should be set up as shown on Dwg. B-310/1-2.
- Centre-point voltage setting:
 - Set the output of the audio generator to 0 (off).
 - Connect the voltmeter between the output, pin 61, and common, pin 67.
 - Adjust R38 for 0V, ± 5 mV at this point.
 - Move the voltmeter lead from pin 61 to pin 62.
 - Adjust R41 for 0V, ± 5 mV, at this point.
 - Quiescent Current setting:
 - Set the output of the audio generator to 0 (off).
 - Connect the voltmeter across R84.
 - Adjust R36 for a reading of 30-35mV.
 - Connect the voltmeter across R84 and adjust R37 for the same reading.
 - After completing steps a and b, allow the AT310 to idle for approximately 15 minutes, then repeat the adjustments.

5.07 Gain Test:

- a) Set up the test equipment as shown on Dwg. B-310/1-2.
- b) Set R20, the front panel gain control, fully clockwise and R20A fully counter-clockwise.
- c) Set the audio generator output to -20dBm at 1kHz, 600 ohms balanced.
- d) Read the output level on the distortion analyzer. It should be +20dBm, minimum.
- e) Remove the 820 ohm feedback gain resistor.
- f) Read the output level, it should be 0dBm, minimum.

5.08 Distortion Test:

- a) Set up the test equipment as shown on Dwg. B-310/1-2.
- b) Remove the 820 ohm feedback gain resistor.
- c) Set the audio generator output to 0dBm at 1kHz, 600 ohms balanced.
- d) Adjust gain control, R20, for an output of +18dBm.
- e) Read the amount of distortion, it should be less than 0.2%.
- f) Repeat steps c,d,and e at 20Hz, and 20kHz keeping the input and output levels the same. The distortion should remain less than 0.2%
- g) Set the audio generator output to +18dBm at 1kHz, 600 ohms balanced.
- h) Adjust gain control R20, for an output of +18dBm.
- i) Read the amount of distortion, it should be less than 0.2%.
- j) Repeat steps g,h and i at 20Hz, and 20kHz keeping the input and output levels the same. The distortion should remain below 0.2%
- k) Set the audio generator output to +18dBm at 1kHz, 600 ohms balanced.
- l) Adjust the gain control, R20, for an output of +25dBm.
- m) Read the amount of distortion. It should be less than 0.25%.
- n) Repeat steps k,l, and m at 20Hz and 20kHz, keeping the input and output levels the same. The distortion should remain below 0.25%

5.09 Frequency Response Test.

- a) Set up the test equipment as shown on Dwg. B-310/1-2.
- b) Remove the 820 ohms, feedback gain resistor.
- c) Set the audio generator output to -10dBm at 1kHz, 600 ohms, balanced.
- d) Adjust the gain control, R20, for an output of +8dBm.
- e) Sweep the generator from 20Hz to 20kHz, the output should remain within ± 0.25 dB of that at 1kHz.

5.10 Final Step:

Leave the gain control as set under test 5.09. Refer to 3.15 and 3.16 for the final level adjustment as installed in a system.

5.11 This completes the test procedures.

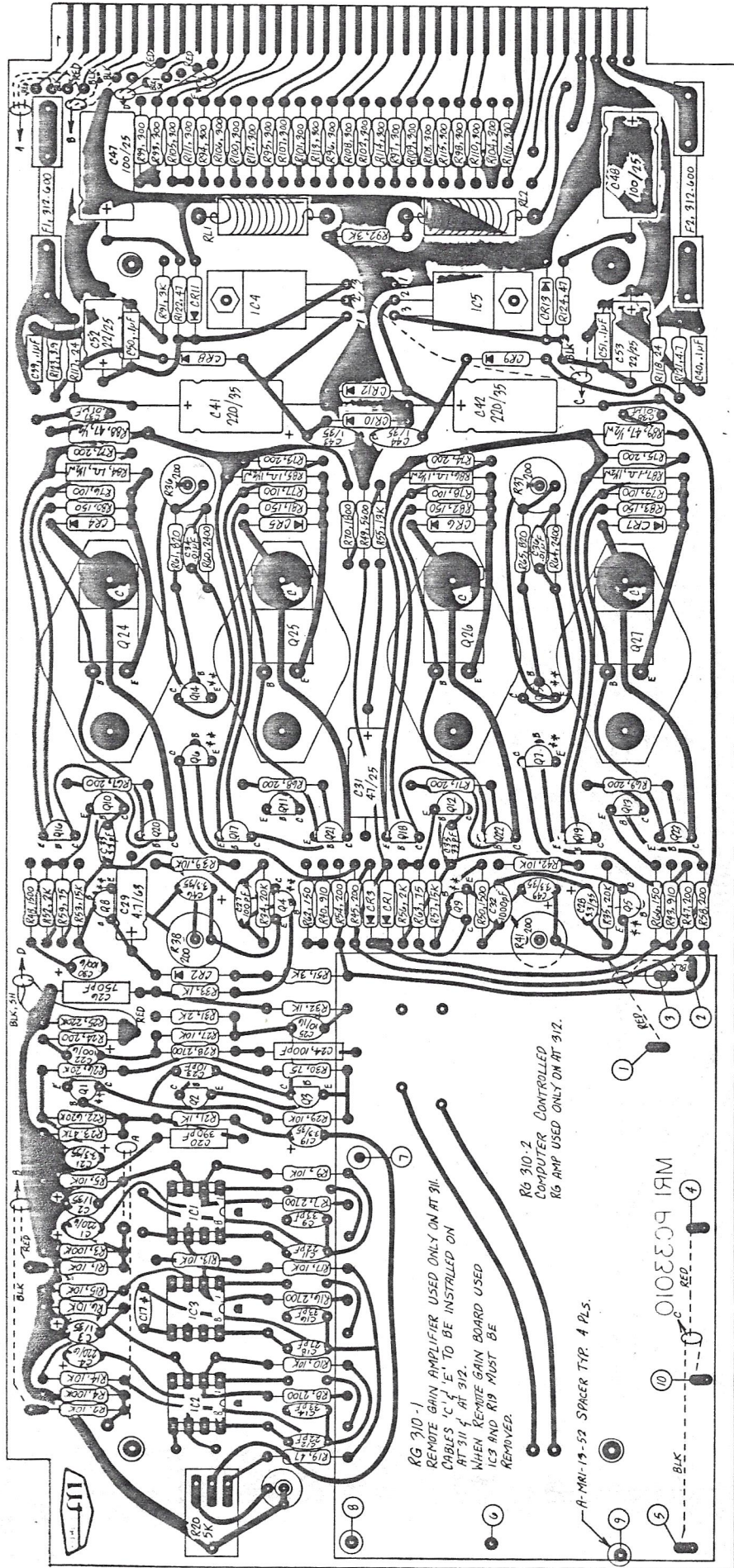

INSTALL Q24 TO Q27 AS FOLLOWS:

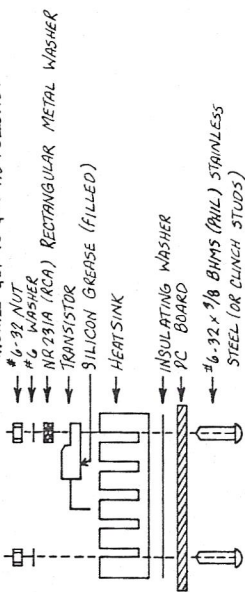

Q24 & 26 ARE 2N6292 (2N6910).
 Q25 & 27 ARE 2N6107 (2N6318).
 Q28 & 29 ARE 2N3053.
 OTHER LEADS AS SHOWN.
 Q14 TO BE THERMALLY LINKED TO HEATSINKS OF Q24 & 25.
 Q15 " " Q26 & 27.
 LEAD MUST BE CLAMPED WHEN BENDING
 SO THAT NO STRESS IS CREATED AT THIS
 POINT.

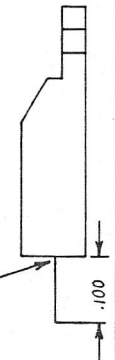

RG 310-1
 REMOTE GAIN AMPLIFIER USED ONLY ON AT 311.
 CABLES 'C', 'E' TO BE INSTALLED ON
 AT 311 & AT 312.
 WHEN REMOTE GAIN BOARD USED
 IC3 AND R19 MUST BE
 REMOVED.

RG 310-2
 COMPUTER CONTROLLED
 RG AMP USED ONLY ON AT 312.

A-MRI-13-59 SPACER TYP. 4 PLS.

NOTES:
 ALL RESISTORS ARE 1/4W, 1% UNLESS OTHERWISE SPECIFIED.
 CR1 & CR9 ARE M22961.
 CR2 IS IN5158B.
 CR4, 5, 6, 7, 10, 11 ARE IN5060.
 CR8 & CR9 ARE IN5338B.
 Q1, 4, 5, 6, 7, 8, 9, 14 & 15 ARE T1S97 OR T1S94 *.
 Q2 IS 2N5087.
 Q3, 10, 12, 17, 19, 21 & 23 ARE M2SFS6.
 Q11, 13, 16, 18, 20 & 22 ARE M2S9A06.
 * DENOTES 5% TYPE J CAPACITOR
 IC1, 2 & 9 ARE NE531V
 IC4 IS LM315N.
 * OPTIONAL
 ** WHEN T1S97 IS REPLACED WITH T1S94, THE DEVICES MUST BE
 INSTALLED AS SHOWN BELOW:



DRAWN: DAB		APPROVED: [Signature]	McCURDY RADIO INDUSTRIES
CHECKED: JS	SCALE: 2:1	COMPONENT LAYOUT AND ASSEMBLY AT 310	
DESIGN: JS	DATE: JUNE 24/80	DISTRIBUTION AMPLIFIER	
ALL DIMENSIONS IN INCHES DO NOT SCALE		DRAWING NO. 310-1	

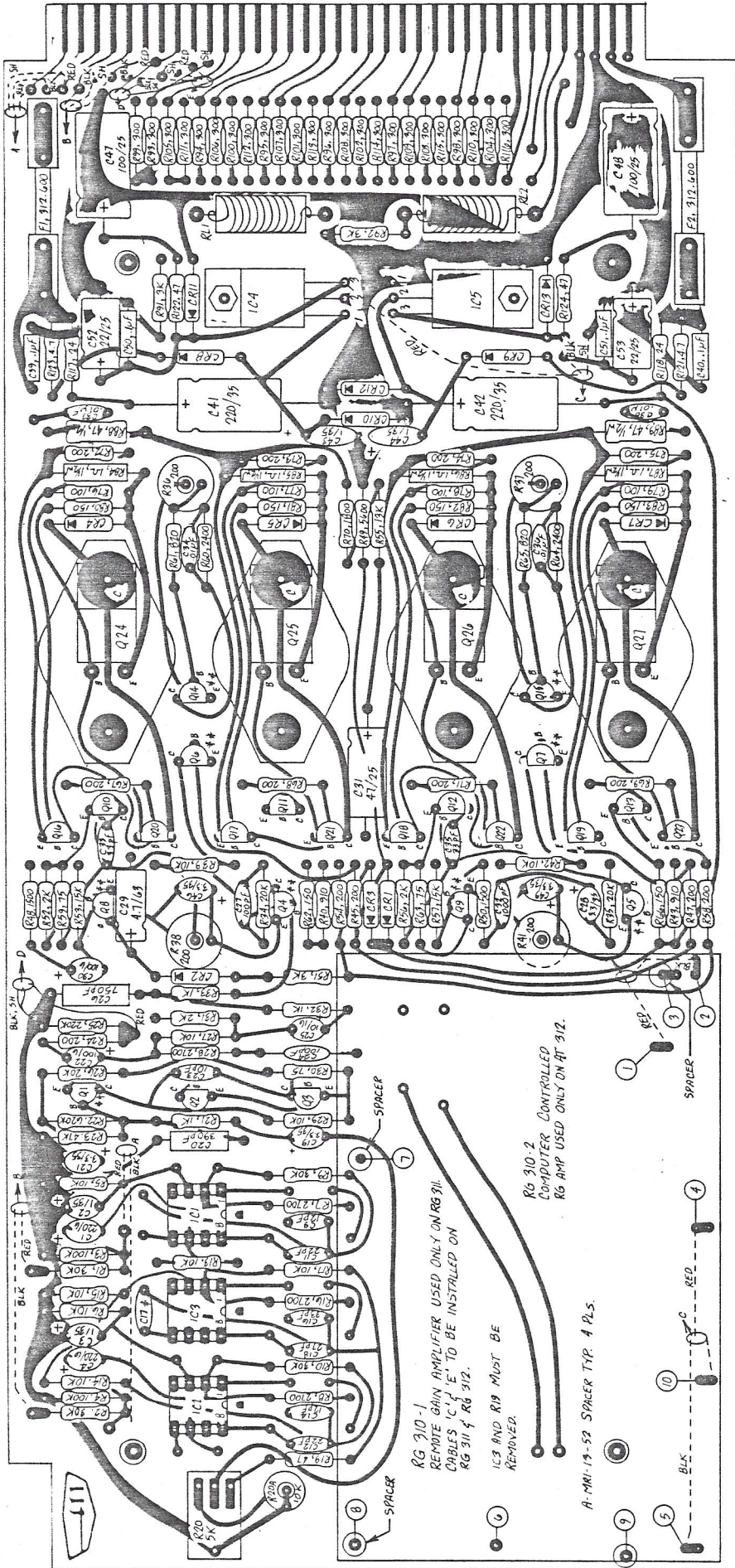

NOTES:

- ALL RESISTORS ARE 1/4W, 5%, UNLESS OTHERWISE SPECIFIED.
- CR1 & CR3 ARE M22261.
- CR2 IS IN5750B.
- CR4, 5, 6, 7, 10, 11 ARE IN5000.
- CR8, 11, 12, 13, 14, 15, 16, 17, 18, 20, 21, 22 ARE MP2406.
- * DENOTES 5% TYPED TYPE J CAPACITOR
- IC1, 2 & 9 ARE NE531V
- IC4 IS MCT8M5C.
- * OPTIONAL
- ** WHEN T1S97 IS REPAIRED WITH T1S94, THE DEVICES MUST BE INSTALLED AS SHOWN BELOW:
- IC5 MCT815.

RG 310-1
REMOTE GAIN AMPLIFIER USED ONLY ON RG 311.
CABLES 'C', 'E' TO BE INSTALLED ON
RG 311 & RG 312.

IC3 AND R19 MUST BE
REMOVED.

RG 310-2
COMPUTER CONTROLLED
RG AMP USED ONLY ON AT 312.

A-MRI-12-52 SPACER TYP. 4 PLS.

Q24 & Q26 ARE 2N6292 (2N6316).
Q25 & Q27 ARE 2N5101 (2N6318).
Q28, Q29 ARE 2N3053.
FOR Q24, 25, 26 & 27 CUT CENTRE LEAD & DRESS
OTHER LEADS AS SHOWN.
Q14 TO BE THERMALLY LINKED TO HEATSINKS OF Q24 & 25.
Q15 " " Q26 & 27.
LEAD MUST BE CLAMPED WHEN BENDING
SO THAT NO STRESS IS CREATED AT THIS
POINT.

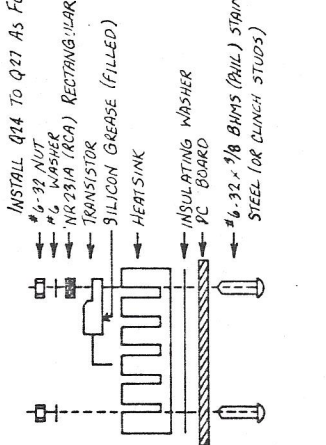

McCurdy Radio Industries COMPONENT LAYOUT AND ASSEMBLY AT 310-30		APPROVED: <i>AK</i> SCALE: 2:1 DATE: JUNE 24/80	DESIGNER: JS ALL DIMENSIONS IN INCHES DO NOT SCALE
DRAWN: DAB CHECKED:	APPROVED:	DATE:	
www.SteamPoweredRadio.Com			

DO NOT SCALE

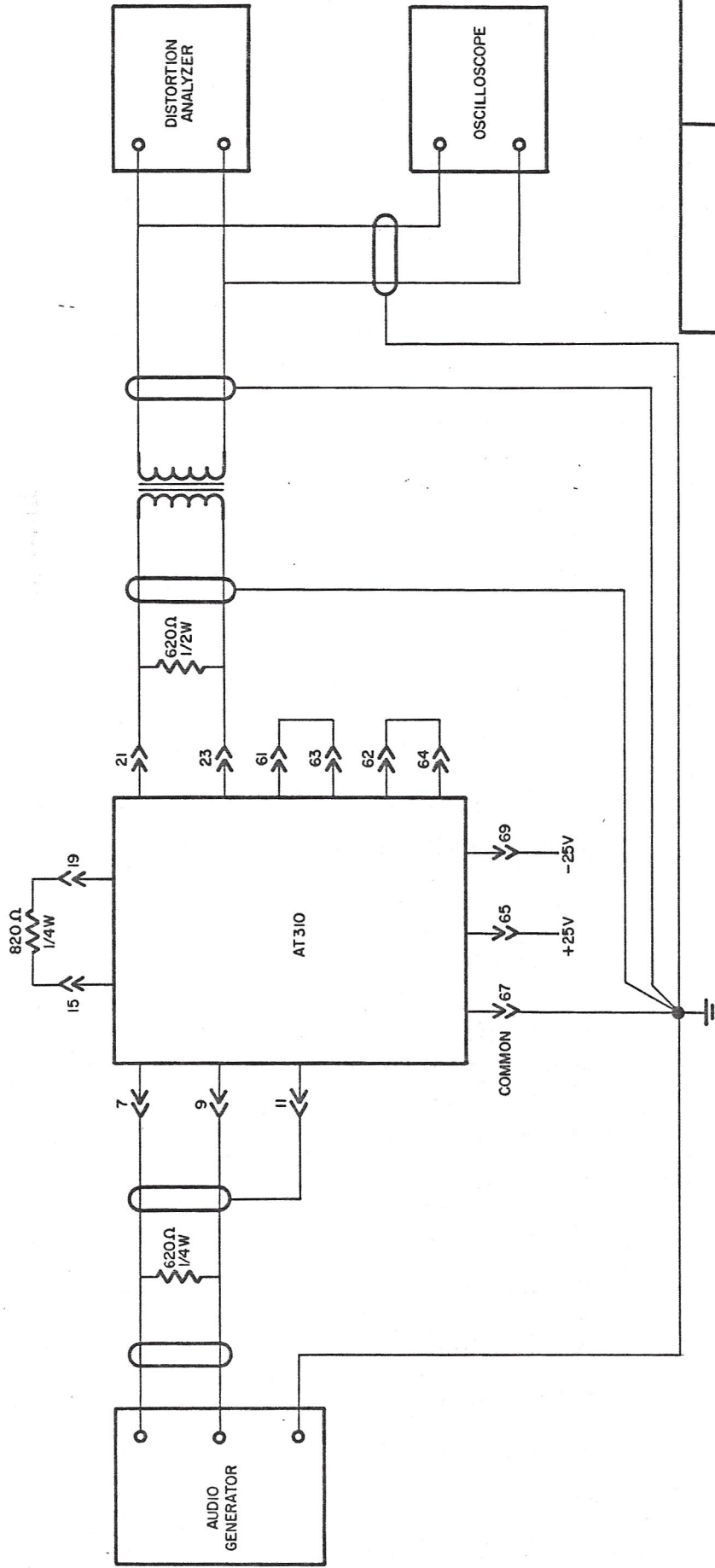

<p>McCURDY RADIO INDUSTRIES</p> <p>AT310</p> <p>TEST SETUP</p>		<p>UNIT--</p> <p>B-310/1-2</p>	
		<p>DRAWING No.</p>	
<p>DRAWN--</p> <p>VW</p>	<p>APPROVED--</p>	<p>CHECKED--</p>	<p>SCALE--</p>
<p>DESIGN--</p>	<p>DATE--</p> <p>JUNE 18/76</p>	<p>ALL DIMENSIONS IN INCHES DO NOT SCALE</p>	
<p>TOLERANCES UNLESS OTHERWISE SPECIFIED</p>	<p>DECIMAL ± .005</p> <p>FRACTIONAL ± 1/64</p> <p>ANGULAR ± 1/2°</p>	<p>MATERIAL--</p>	
<p>FINISH--</p>		<p>www.SteamPoweredRadio.Com</p>	
<p>ISSUE</p>		<p>DU TRANSTEX 18 2103-9-76</p>	

Section 6 PARTS LIST

6.01 List of replaceable parts.

NOTE: The $\frac{1}{4}W$ and $\frac{1}{2}W$, $\pm 5\%$ resistors are stock items, they are not listed.

<u>REFERENCE DESIGNATION</u>	<u>SUPPLIER AND PART NUMBER</u>	<u>DESCRIPTION</u>
R84, R85, R86, R87	Ohmite 4030	Resistor, WW, 1 ohm, $1\frac{1}{2}W$, $\pm 5\%$
R38, R36, R41, R37	Beckman 91AR250	Potentiometer, 250 ohm
R20	PEC LU5021	Potentiometer, 5K ohm
R20A	Bourns 3329H-1-103	Potentiometer, 10K ohm
C23	Philips 2222 638 10109	Capacitor, Ceramic, 10pF, $\pm 2\%$
C10, C11, C12, C13	Philips 2222 638 58229	Capacitor, Ceramic, 22pF, $\pm 2\%$
C18	Philips 2222 638 58279	Capacitor, Ceramic, 27pF, $\pm 2\%$
C9, C14, C16, C33, C35	Philips 2222 638 58339	Capacitor, Ceramic, 33pF, $\pm 2\%$
C24, C27	Philips 2222 638 70101	Capacitor, Ceramic, 100pF, $\pm 2\%$
C32	Philips 2222 629 03102	Capacitor, Ceramic, 1000pF, $\pm 20\%$
C34, C36, C37, C38	Philips 2222 629 03103	Capacitor, Ceramic, .01uF, $\pm 20\%$
C20	Philips 279ACC390	Capacitor, Polystyrene, 390pF, $\pm 2\%$
C26	Philips 279ACC750	Capacitor, Polystyrene, 750pF, $\pm 2\%$
C39, C40, C50, C51	Philips 280AEA100K	Capacitor, Mylar Film, 1uF, $\pm 2\%$
C2, C3, C43, C44	ITT TAG1M35	Capacitor, Tantalum, 1uF, 35V, $\pm 20\%$
C19, C21, C28, C46, C49	ITT TAG3.3M35	Capacitor, Tantalum, 3.3uF, 35V, $\pm 20\%$
C25	ITT TAG10M16	Capacitor, Tantalum, 10uF, 16V, $\pm 20\%$
C45	ITT TAG22M35	Capacitor, Tantalum, 22uF, 35V, $\pm 20\%$
C22, C30	ITT TAG100M6	Capacitor, Tantalum, 100uF, 6V, $\pm 20\%$
C1, C4	ITT TAG200M6	Capacitor, Tantalum, 220uF, 6V, $\pm 20\%$
C29	Philips 437ETH4.7	Capacitor, Electrolytic, 4.7uF, 63V
C42, C53	Siemens B41313	Capacitor, Electrolytic, 22uF, 63V

<u>REFERENCE DESIGNATION</u>	<u>SUPPLIER AND PART NUMBER</u>	<u>DESCRIPTION</u>
C31	Siemens B41283	Capacitor, Electrolytic, 47uF, 40V
C47, C48	Siemens B41283	Capacitor, Electrolytic, 100uF, 25
C41, C42	Siemens B41283	Capacitor, Electrolytic, 220uF, 35
CR4, CR5, CR6, CR7, CR10, CR11	Gen. Inst. 1N5060	Diode, Silicon
CR2	Motorola 1N5258B	Diode, Zener
Q3, Q10, Q12, Q17, Q19, Q21, Q23	Motorola MPSA56	Transistor, Silicon, PNP
Q11, Q13, Q16, Q18, Q20, Q22	Motorola MPSA06	Transistor, Silicon, NPN
Q24, Q26 (See Note 1)	RCA 2N6292 or Motorola 2N6316	Transistor, Silicon, NPN
Q25, Q27 (See Note 1)	RCA 2N6107 or Motorola 2N6318	Transistor, Silicon, PNP
Q28, Q29	RCA 2N3053	Transistor, Silicon, NPN
IC1, IC2, IC3 (See Note 1)	Signetics NE531V or TI SN72709P	Integrated Circuit
IC4	National LM325N	Integrated Circuit
F1, F2	Littelfuse 312.600	Fuse, 600mA
--	Littelfuse 102069	Fuse Clip
--	Thermalloy 7717-123	Transipad, T05
--	TI 830802	Integrated Circuit Socket, 8-pin
--	TI 831402	Integrated Circuit Socket, 14-pin
--	Thermalloy 2257	Heatsink, T05, Round
--	Thermalloy 1136B	Heatsink, T05, Square
--	Thermalloy 6017B	Heatsink, T066
C9, C14 (See Note 2)	Philips 2222 638 10129	Capacitor, Ceramic, 12pF, <u>+2%</u>

NOTES:

- 1) Replace only with type supplied in unit.
- 2) AT310-30 only. All other parts are the same as AT310.

<u>REFERENCE DESIGNATION</u>	<u>SUPPLIER AND PART NUMBER</u>	<u>DESCRIPTION</u>
CR8, CR9	Motorola 1N5338B	Diode, Zener
CR1, CR3	Motorola MZ2361	Diode, Reference
Q1, Q4, Q5, Q6, Q7, Q8, Q9, Q14, Q15	TI T1597	Transistor, Silicon, NPN
Q2	Motorola 2N5087	Transistor, Silicon, PNP

INSTRUCTIONS PS855 REGULATED POWER SUPPLY

INDEX

<u>Section</u>	<u>Subject</u>	<u>Page</u>
1	General Description	2
2	Specifications	3
3	Installation	4
4	Circuit Description	6
5	Maintenance	11
6	Parts List	16

LIST OF ILLUSTRATIONS

<u>Figure</u>	<u>Title</u>	<u>Page</u>
3-1	Frame Connector Wiring	5
4-1	Schematic, PS855	8
4-2	Schematic, Regulator Card	9
4-3	Schematic, Control Card	10
5-1	Test Setup	14
5-2	Component Layout, Regulator Card	15
5-3	Component Layout, Control Card	15

McCURDY RADIO INDUSTRIES LIMITED

108 CARNFORTH ROAD, TORONTO, ONTARIO M4A 2L4 (416) 751-6262, TELEX 06-963533, TWX 610-492-1373

McCURDY RADIO INDUSTRIES INC.

UNITED STATES HEAD OFFICE

1711 CARMEN DRIVE, ELK GROVE VILLAGE, ILLINOIS 60007, (312) 640-7077, TWX 910-222-0436

EAST COAST OFFICE

223 WEST SADDLE RIVER ROAD, SADDLE RIVER, N.J. 07458, (201) 327-0750, TWX 710-988-2254

BUFFALO WAREHOUSE

1051 CLINTON STREET, BUFFALO, N.Y. 14206, DIRECT LINE TO TORONTO PLANT (716) 854-6700, TWX 610-492-1373



McCurdy Radio Industries reserves the right, without notice to make such changes in equipment, design, specifications, or components as progress in engineering or manufacturing techniques may warrant to improve the performance of the product.

GENERAL DESCRIPTION

The P2825 is a self contained solid-state power supply designed primarily for use in the McCurdy line of audio distribution systems. The P2825 supplies +25 and -25 Volts regulated DC at up to 1 Ampere.

The P2825 is supplied wired for operation on 115V, 50/60Hz AC. It is possible to reconnect the power transformer for operation on 105V, 210V, or 230V, 50/60Hz AC. See section 5 for conversion information.

Any combination of amplifiers may be created from one P2825 within a system, as the low dynamic output impedance of the supply minimizes cross coupling.

Complete overload, over-voltage, short-circuit and fault protection is built into the P2825. Two front panel LED indicators are provided, one indicates normal +25V output and the other flashes when a fault condition is present. See section 3 for a detailed description.

Silicon semiconductors are used in the P2825 to ensure reliability. The power supply is constructed on a rigid metal chassis designed to plug into the FR900 equipment frame. A maximum of four (4) P2825 power supplies may be mounted in one frame. Cooling of the supply is by convection, no external cooling equipment is necessary.

The control and regulator circuitry is assembled onto two glass-epoxy printed circuit boards. These boards plug into edge connectors located on the main power supply chassis.

Section 1. GENERAL DESCRIPTION.

- 1.01 The PS855 is a self contained solid-state power supply designed primarily for use in the McCurdy line of audio distribution systems. The PS855 supplies +25 and -25 Volts regulated DC at up to 2 Amperes.
- 1.02 The PS855 is supplied wired for operation on 115V, 50/60Hz AC. It is possible to reconnect the power transformer for operation on 105V, 210V, or 230V, 50/60Hz AC. See Section 5 for conversion information.
- 1.03 Any combination of amplifiers may be operated from one PS855 within a system, as the low dynamic output impedance of the supply minimizes cross coupling.
- 1.04 Complete overload, over-voltage, short-circuit and fault protection is built into the PS855. Two front panel LED indicators are provided, one indicates normal $\pm 25V$ output and the other flashes when a fault condition is present. See Section 3 for a detailed description.
- 1.05 Silicon semiconductors are used in the PS855 to ensure reliability. The power supply is constructed on a rigid metal chassis designed to plug into the FR906 Equipment frame. A maximum of four (4) PS855 power supplies may be mounted in one frame. Cooling of the supply is by convection; no external cooling equipment is necessary.
- 1.06 The control and regulator circuitry is assembled onto two glass-epoxy printed circuit boards. These boards plug into edge connectors mounted on the main power supply chassis.

Section 2. SPECIFICATIONS.

- 2.01 Voltage:
+25V and -25V DC, regulated.
- 2.02 Load Current:
0 to 2 Amps.
- 2.03 Regulation:
 - a) Line; 0.5% for input voltages from 105 to 125V. AC
 - b) Load; 0.5% for loads from zero to 2 Amps.
- 2.04 Ripple and Noise:
Less than 500uV, RMS, for line and load variations specified above.
- 2.05 Internal Impedance:
Less than 0.1 ohm, DC to 20kHz.
- 2.06 Overload Protection:
Internal current limiting at 2 Amps. Short circuit proof for infinite time.
- 2.07 Overvoltage Protection:
Internal relay crobar circuit protects against failure. Output voltage limited to 25V.
- 2.08 Cooling:
By convection.
- 2.09 Primary Power Requirements:
 - a) Power transformer primaries in parallel, as supplied
105 to 125V, 115V AC nominal, 50/60Hz, 500VA maximum.
95 to 115V, 105V AC nominal on low voltage taps.
 - b) Power transformer primaries in series,
210 to 250V, 230V AC nominal, 50/60Hz, 500VA maximum.
190 to 230V, 210V AC nominal on low voltage taps.
- 2.10 Ambient Temperature Range:
0°C to 55°C, continuous duty cycle at full load current.
- 2.11 Dimensions:
4½" (114mm) high, 4-1/4"(108mm) wide, 11-5/8" (295mm) long.
- 2.12 Weight:
12 pounds, (5.4kg).

Section 3. INSTALLATION.

- 3.01 The PS855 is designed to plug into a McCurdy type FR906 equipment frame. This frame may be mounted in a standard 19" rack or pedestal and occupies 5-1/4" of vertical space. The FR906 will hold up to four PS855 power supplies.
- 3.02 A connector mounting bracket, McCurdy A852/5-3, is required to mount the Amphenol type 26-4101-24 "Blue Ribbon" connector in the FR906 frame. The bracket must be mounted on two 3/8" long spacers, McCurdy A-MRI-13-4, with 4-40 hardware. To prevent hazardous AC voltages from being exposed a connector cover, McCurdy A852/5-4, should be mounted over the wired connector.
- 3.03 To obtain maximum performance over extended periods of time, ensure that the PS855 is not required to supply more than two Amps and that the ventilation holes in the mounting frame are not obstructed. Therefore, allowing the maximum amount of cooling air to flow through the power supply.
- 3.04 All connections to external equipment are made to the frame receptacle that mates with P1 on the power supply. This receptacle is designated herein as J1, although it may be stamped with another designation when installed in a system.
NOTE: Connect AC power last. Refer to Figure 3-1 for details of pin connections.
- 3.05 DC output connections.
The +25 Volt output is taken from J1-9 and the -25 Volt output from J1-11. The common for both voltages is taken from J1-10 and J1-22.
- 3.06 Grounding.
Chassis ground connects to J1-14. This should be run to system ground via an insulated, stranded, 12 gauge wire.
- 3.07 AC power connections.
As supplied, the PS855 require 117V, 50/60Hz, single phase AC at 500 VA maximum. See Section 5 if 230V power is required. The AC connects to J1-3 and J1-1. The neutral should be connected to J1-3.
- 3.08 Indicator and fault lamp operation.
Two LED indicators are provided on the front panel, one indicating $\pm 25V$ output and the other indicating "fault".

- 3.08 a) Normally the $\pm 25V$ indicator will be lit and the fault indicator will be off.
 b) If both indicators are off, either the AC fuse, F1, has blown or the relay overvoltage circuit has been activated.
 c) When the $\pm 25V$ indicator is off and the fault indicator is flashing, an overload or short circuit is present on the output lines. In some cases, when the power supply is overloaded, the $\pm 25V$ indicator will glow dimly when the fault indicator is off and go off completely when the fault indicator lights.

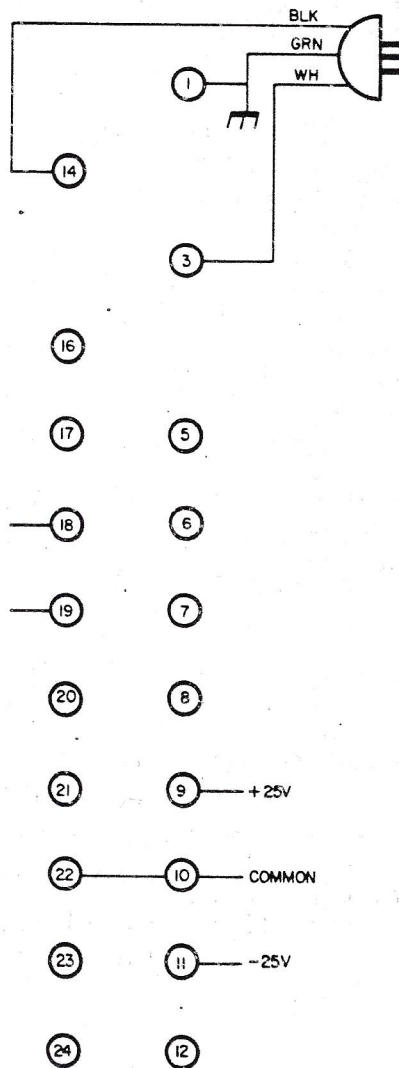

Figure 3-1. Frame Connector Wiring.

Section 4 CIRCUIT DESCRIPTION.

- 4.01 The schematic of the PS855 is shown in Figures 4-1,4-2,and 4-3. Components mounted on the main chassis are shown in Figure 4-1, Figures 4-2 and 4-3 showing the components on the regulator and control cards, respectively. Refer to these figures for identification of components mentioned in the following description.
- 4.02 The low voltage AC from the power transformer, T1, is rectified by the bridge rectifier, CR1-CR4 and filtered by capacitor C3-C6. The common for both the positive and negative voltage is provided by the centre tap on the power transformer secondary winding.
- 4.03 The positive and negative regulators, on the regulator PC board, provide regulation and additional filtration for the 25 Volt outputs. Both regulators are nearly identical,therefore only the positive regulator will be referred to in the following description.
- 4.04 Integrated circuit IC1, functioning as an error amplifier, provides a very stable voltage for driving transistor Q7, which in turn drives the series pass transistor Q1, on the main chassis. Power is supplied to IC1 and the reference voltage circuitry by Q1.
- 4.05 Fault Circuit.
Transistor Q8, on the control card, is normally held 'on' by the positive output voltage through zener diode CR16. If this output drops below a predetermined voltage, diode CR16 no longer conducts, allowing Q8 to turn off. This causes bi-directional switch Q9 to operate, turning on Q6, IC2A and Q4.
- 4.06 Transistor Q4, in turn, switches on the multivibrator circuit consisting of IC1 and associated components. This circuit switches transistor Q3, on the control card, therefore, turning the 25V output on and off. The switching rate is approximately 2 seconds off and 200 milliseconds on. The multivibrator output is inverted by IC2 in order that transistor Q4, in the negative regulator, may be switched together with Q3.
- 4.07 The fault indicator, CR5, on the main chassis, is driven by transistor Q7 from the output of the multivibrator circuit. This causes the indicator to flash on and off when the overload circuit activates.

- 4.08 If the overload or short circuit is no longer present when the multivibrator turns the regulators on, normal operations will be restored. If, however, the overload is still present, the overload circuit will continue to operate, switching the regulators on and off.
- 4.09 Should the overload or short occur on the negative output, transistor Q5 will be turned off, via zener diode CR12, when the output rises, becomes less negative, above a predetermined voltage. This causes transistor Q8 to turn off; via zener CR15, and activating the fault circuit as previously described.
- 4.10 **Overvoltage Circuit.**
When the positive output voltage rises above a predetermined point, diode CR4, on the control card, starts to conduct. This supplies gate voltage to thyristor CR3, causing it to fire. This energizes relay K1, on the main chassis, thus interrupting the power supplied to the regulators. Transistor Q1 functions as a constant current source, ensuring that K1 will operate rapidly once CR3 starts to conduct.
- 4.11 Should the overvoltage condition occur on the negative output, transistor Q3 will be turned 'on' when the output drops, becomes more negative, below a predetermined voltage. This causes transistor Q2 also to be turned 'on' thus firing CR3 and operating relay K1, as described above.
- 4.12 Once the overvoltage circuit has triggered, it can only be reset by turning the power supply off, waiting a few seconds and turning it back on again.

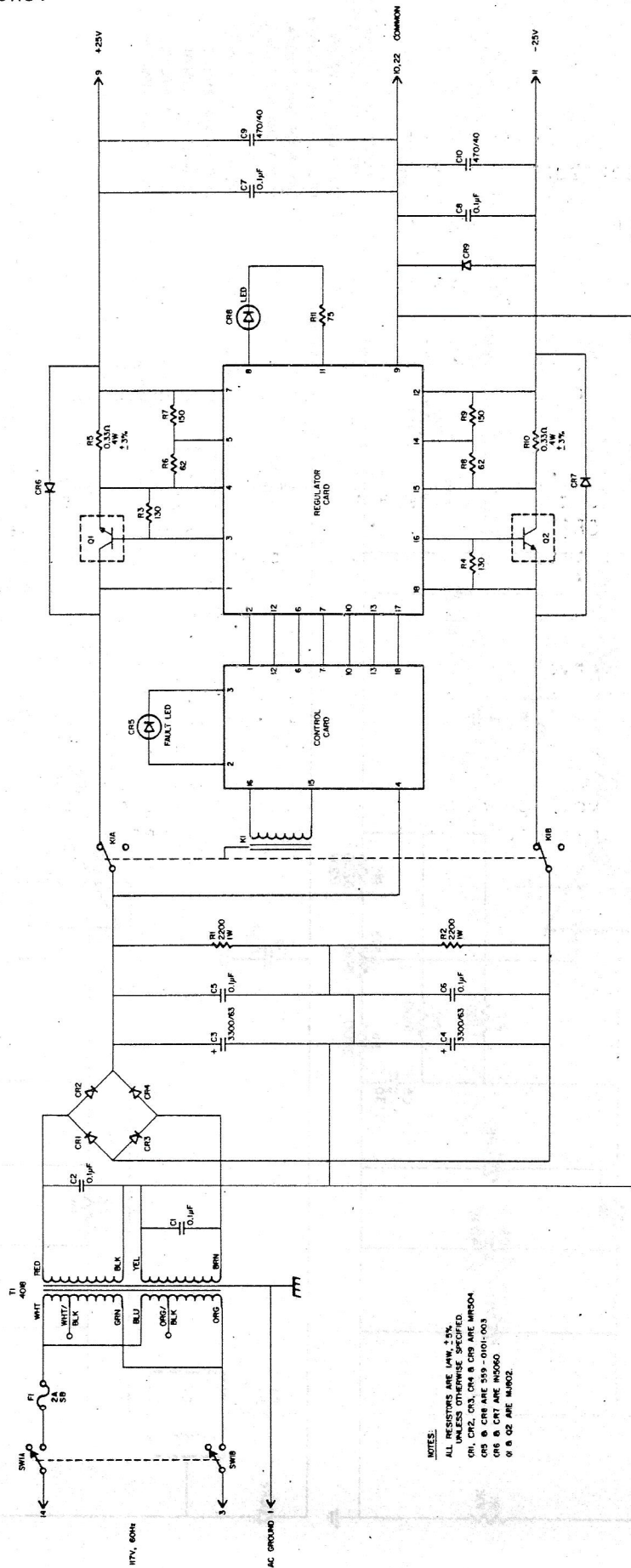

Figure 4-1. Schematic PS855

NOTES:

- ALL RESISTORS ARE 1/4W ±5%, UNLESS OTHERWISE SPECIFIED.
- CR1 & CR2 ARE MZ2361.
- CR3 & CR4 ARE 1N5278.
- CR5 & CR6 ARE 1N625A.
- CR7 & CR8 ARE 1N4148.
- CR9 & CR10 ARE 1N4748A.
- IC1 & IC2 ARE MC174(CP).
- Q1 & Q2 ARE 2N5679.
- Q3 & Q4 ARE 2N5681.
- Q5 & Q6 ARE MPSA06.
- Q7 & Q8 ARE MPSA56.

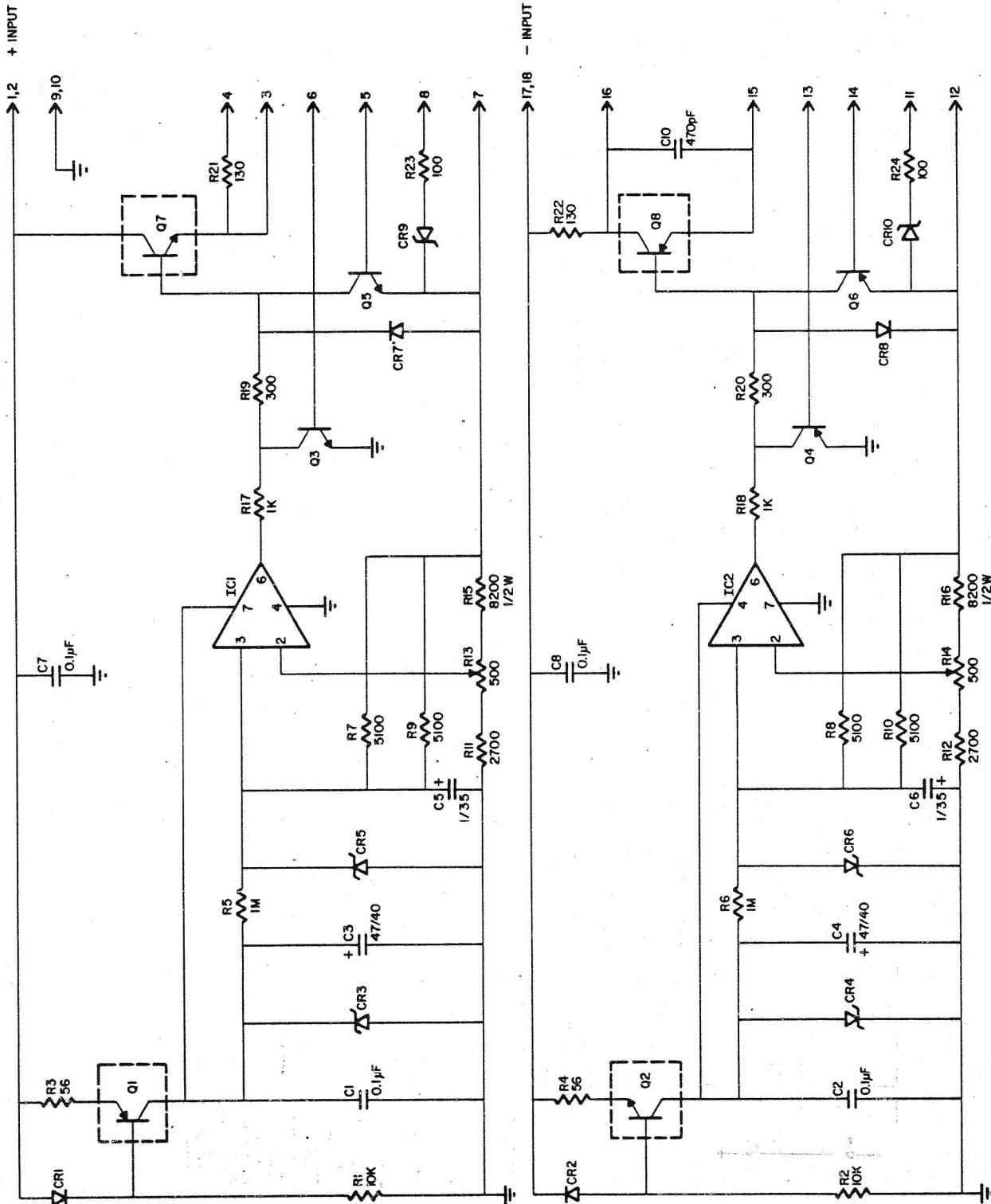
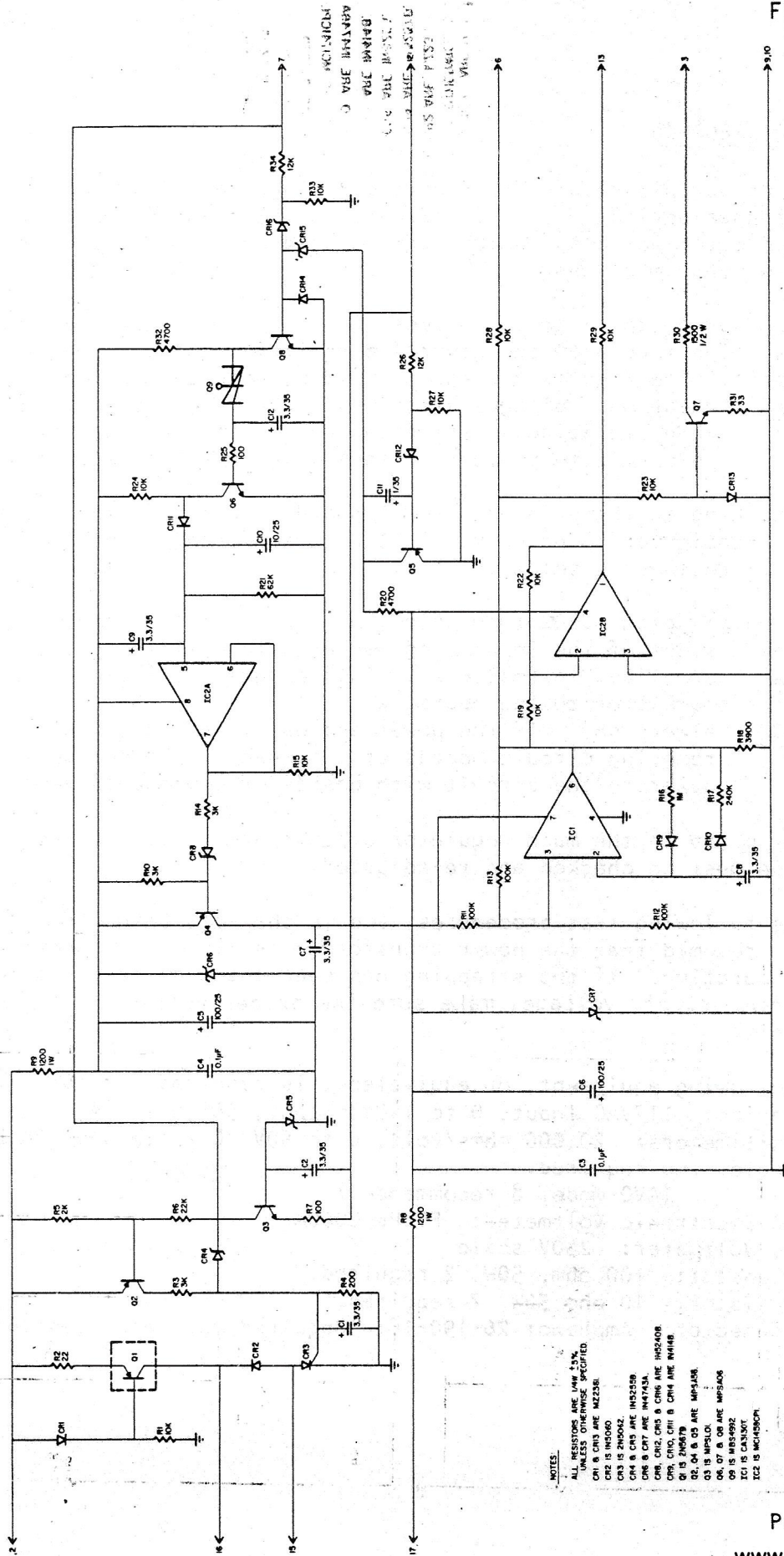

Figure 4-2. Schematic, Regulator Card.

Figure 4-3. Schematic, Relay Control Card.



- NOTES:
- 1. ALL RESISTORS ARE 1/4W 5% UNLESS OTHERWISE SPECIFIED.
 - 2. Q1 IS 2N4301.
 - 3. Q2 IS 2N4004.
 - 4. Q3 & Q4 ARE 1N4148.
 - 5. Q5 & Q6 ARE 1N4733.
 - 6. Q7 & Q8 ARE 1N4750.
 - 7. Q9 IS 1N4007.
 - 8. Q10 IS 1N4001.
 - 9. Q11 IS 1N4004.
 - 10. Q12 IS 1N4007.
 - 11. Q13 IS 2N4007.
 - 12. Q14 & Q15 ARE 1N4148.
 - 13. Q16 IS 1N4148.
 - 14. Q17 & Q18 ARE 1N4007.
 - 15. Q19 IS 1N4007.
 - 16. Q20 IS 1N4007.
 - 17. Q21 IS 1N4007.
 - 18. Q22 IS 1N4007.
 - 19. Q23 IS 1N4007.
 - 20. Q24 IS 1N4007.
 - 21. Q25 IS 1N4007.
 - 22. Q26 IS 1N4007.
 - 23. Q27 IS 1N4007.
 - 24. Q28 IS 1N4007.
 - 25. Q29 IS 1N4007.
 - 26. Q30 IS 1N4007.

Figure 4-3. Schematic, Control Card.

Section 5 MAINTENANCE.

- 5.01 The power supply should be inspected during regular system maintenance periods. Look for damaged or deteriorated components and loose connections. Remove accumulated dust by means of a soft brush or vacuum cleaner.
- 5.02 Remove the top cover to gain access to the interior of the power supply. The regulator and control circuitry is mounted on two plug-in PC boards. See Figures 5-2 and 5-3 for component location.
WARNING! Hazardous voltages exist within the power supply when operating. Care should be taken when servicing this unit to prevent contact with these voltages.
- 5.03 When working on the printed circuit boards, take care not to damage the board, etching or components. A 25 Watt soldering iron is recommended; use only resin core solder.
- 5.04 When replacing an MJ802 transistor, Q1 and Q2 on the front heatsink, coat both sides of the insulating washer with a filled silicon grease such as Thermalloy "Thermalcote". This ensures efficient heat transfer from the transistor to the heatsink.
CAUTION! Always shut off the power and wait one minute before removing circuit boards or components. Do not apply power to the circuit with boards or components removed.
- 5.05 If any parts in the main regulator circuit are replaced, the output voltage must be checked and re-adjusted.
- 5.06 In the following test procedures, and in the Test Setup, Figures 5-1, it is presumed that the power transformer is wired as standard, for 115V operation. If the strapping has been changed for operation on a different supply voltage, make sure the proper voltage is supplied to the unit.
- 5.07 The following equipment, or equivalent, is required for these tests.
- Variac: 117VAC input, 0 to 140V output, 50/60Hz, 2A.
 - Multimeters: 20,000 ohms/volt, 0 to 50V DC scale and 10A DC scale, two required.
(AVO model 8 recommended)
 - AC Electronic Voltmeter: Fluke 8000A
 - AC Voltmeter: 250V scale
 - Rheostat: 100 ohm, 50W, 2 required.
 - Resistor: 10 ohm, 50W, 2 required.
 - Connector: Amphenol 26-190-16. Required for bench testing.

5.08 Output Voltage Adjustment.

- a) Set up the test equipment as shown in Figure 5-1.
- b) Adjust variac for 115 Volts, set rheostats for maximum resistance.
- c) Turn on power supply and note DC output voltages.
- d) Adjust R13 for +25 Volts out and R14 for -25 Volts out.
- e) Adjust rheostats for a 1A load current and allow PS855 to operate approximately 15 minutes.
- f) Check, and if necessary, readjust R13 and R14 for $\pm 25V$ output.

5.09 Ripple and regulation tests.

- a) Set up the test equipment as shown in Figure 5-1.
- b) Adjust variac for 115 Volts, set rheostats for maximum resistance.
- c) Turn on power supply and note DC output voltages and ripple.
- d) Adjust rheostats for a 2A load current and note DC output voltage and ripple.
- e) Adjust variac for 105V and then 125V and note DC output voltage and ripple in both cases.
- f) In each of the above cases, the DC voltage should not vary more than $\pm 125mV$ nor the ripple exceed 500uV RMS.

5.10 Fault circuit test.

- a) Set up the test equipment as shown in Figure 5-1.
- b) Adjust variac for 115V, set rheostats for maximum resistance.
- c) Turn on power supply and adjust rheostats for 2A load current.
- d) Slowly increase the positive load current. The fault circuit should come into action just above a 2A load current. The fault indicator will flash and the output will pulse on and off.
- e) Reset positive load current to 2A.
- f) Repeat step (d) but with the negative load current.

5.11 Overvoltage circuit test.

- a) Set up the test equipment as shown in Figure 5-1.
- b) Adjust variac for 115V, set rheostats for maximum resistance.
- c) Connect a 15K ohm, 1/4W, $\pm 5\%$ resistor across R15 on the regulator card.
- d) Turn on the power supply.
- e) Slowly increase the output voltage, by adjusting R13, until the overvoltage circuit operates the relay, K1. This should happen at approximately 28V.
- f) Turn off the power supply, remove the resistor placed across R15 and repeat the test on the negative output by placing the resistor across R16 and adjust R14. The overvoltage circuit should function as in step (e).
- g) Switch off power supply and remove resistor placed across R16.
- h) Readjust output voltage by performing the procedure under 5.08, Output Voltage Adjustment.

- 5.12 This completes all test procedures.
- 5.13 Reconnecting the power transformer for low line, 95 to 115V, operation.
- Remove the heavy orange wire from the lower lug on SW1, a heavy green wire is on the same lug, and replace with the orange/black wire from T1.
 - Remove the heavy white wire from the fuseholder, a heavy blue wire is on the same lug, and replace with the white/black wire from T1.
 - The loose ends of the white and orange wires should be protected with sleeving. Dress the wires up behind the filter capacitors on the top of the chassis.
- 5.14 Reconnecting the power transformer for 230V operation
- Remove the green wire from the lower lug on power switch SW1.
 - Remove the blue wire from the fuseholder.
 - Twist the ends of these wires together, solder and cover the bare end with sleeving.
 - Dress these wires under the fuseholder, near the chassis, making sure that they do not interfere with installation of the cover.
- 5.15 Reconnecting the power transformer for 190 to 230V operation.
- Remove the heavy green and orange wires from the lower lug of power switch SW1.
 - Remove the white and blue wires from the fuseholder.
 - Twist the ends of the blue and green wires together, solder and cover the bare end with sleeving.
 - Dress the blue and green wires under the fuseholder, near the chassis, making sure that they do not interfere with installation of the cover.
 - The loose ends of the white and orange wires should be protected with sleeving. Dress the wires up behind the filter capacitors on the top of the chassis.
 - Solder the white/black wire from T1 onto the vacant lug of the fuseholder.
 - Solder the orange/black wire from T1 onto the vacant lug on the power switch SW1.

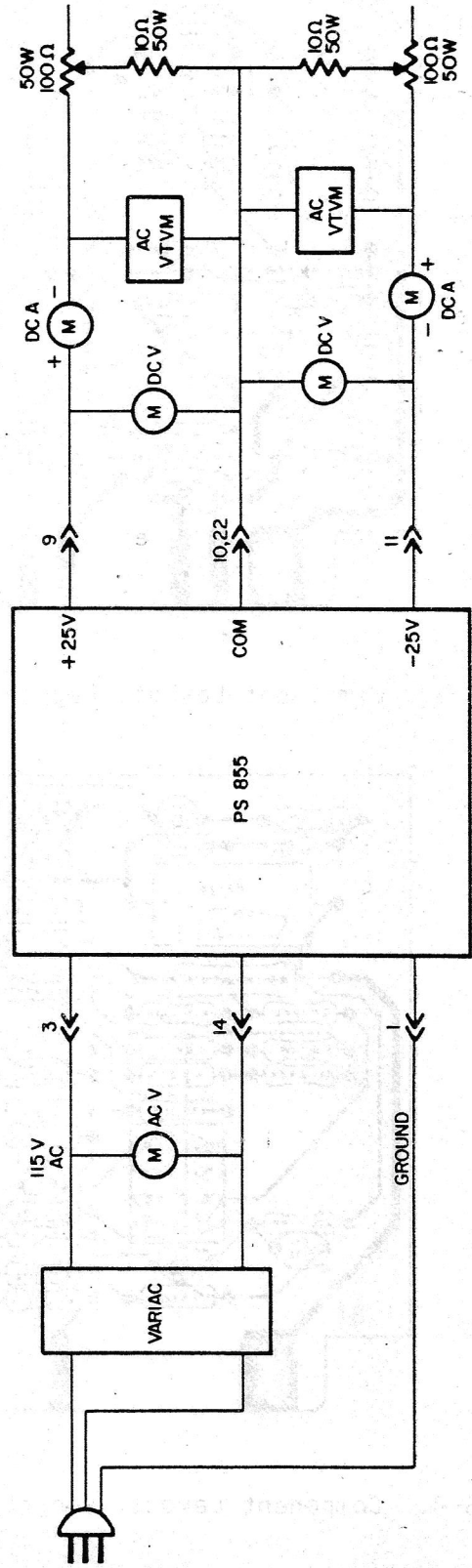

Figure 5-1. Test Setup.

ALL RESISTORS ARE 1/4W ± 5%
UNLESS OTHERWISE SPECIFIED.
CR1, CR2 ARE MZ2361.
CR3, CR4 ARE IN5257B.
CR5, CR6 ARE INB25A.
CR7, CR8 ARE IN414B.
CR9, CR10 ARE IN4748A.
IC1, IC2 ARE MC1741CPI.
Q1, Q2 ARE 2N5679.
Q3, Q4 ARE 2N5681.
Q5, Q6 ARE MPSA06.
Q7, Q8 ARE MPSA56.

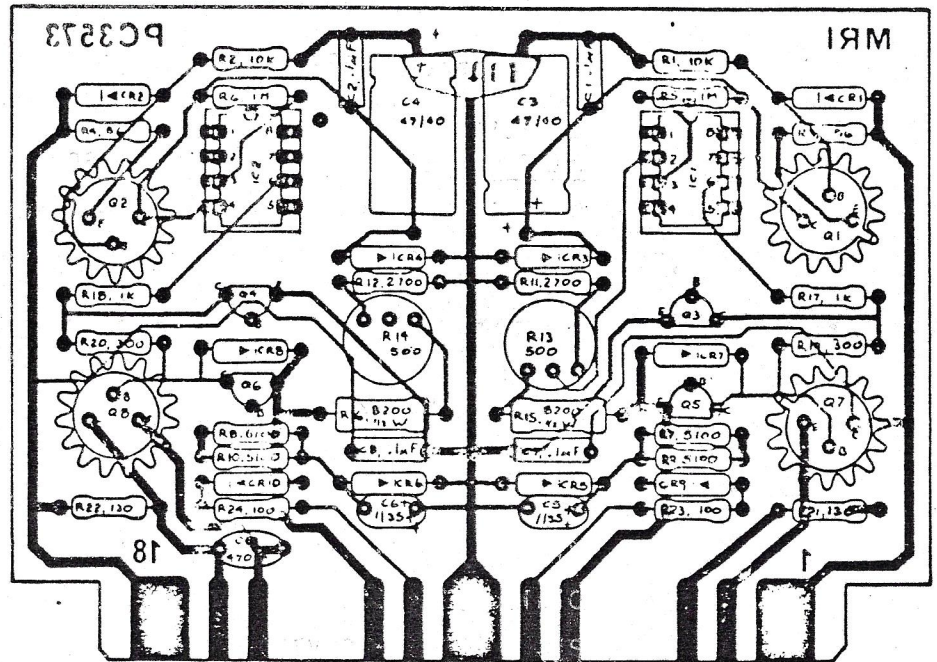

Figure 5-2. Component Layout, Regulator Card.

ALL RESISTORS ARE 1/4W, 15%
UNLESS OTHERWISE SPECIFIED.
CR1, CR3 ARE MZ2361
CR2 IS IN5060
CR3 IS 2N5062
CR4, CR5 ARE IN5255B
CR6, CR7 ARE IN4743A
CR8, CR12, CR15, CR16 ARE INB240B
CR9, CR10, CR11, CR14 ARE IN414B
Q1 IS 2N5679
Q2, Q4, Q5 ARE MP8A56
Q3 IS MP5L01
Q6, Q7, Q8 ARE MP8A06
Q9 IS MB54492
IC1 IS CA310T
IC2 IS MC1450CPI

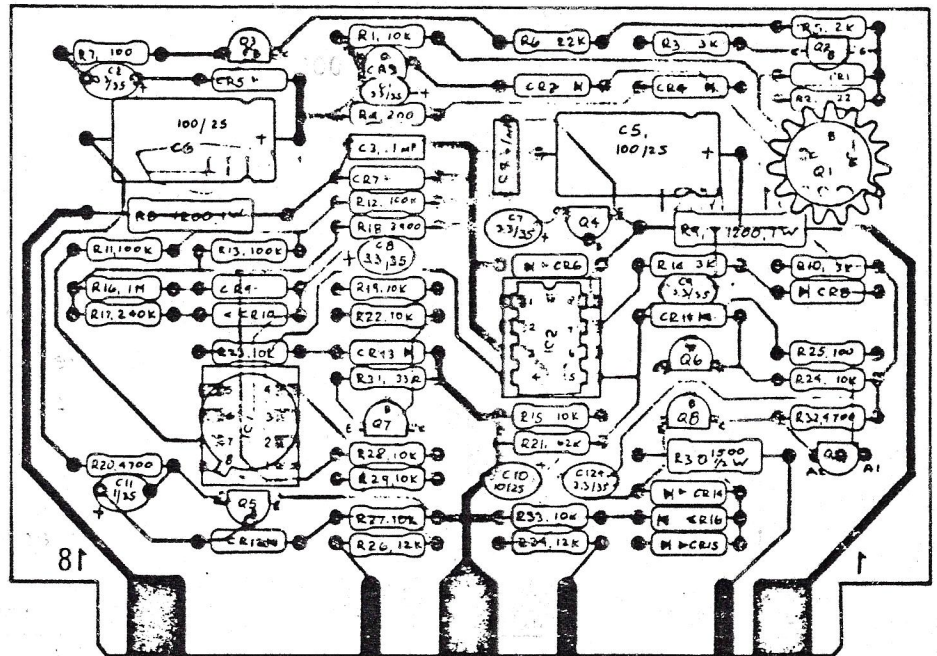

Figure 5-3. Component Layout, Control Card.

PC3573

6.01 List of replaceable parts, PS855 main chassis.

<u>REFERENCE DESIGNATION</u>	<u>SUPPLIER and PART NUMBER</u>	<u>DESCRIPTION</u>
R5, R10	Dale RS-2	Resistor, WW, 4W, $\pm 3\%$ 0.33 ohm
C1, C2, C5, C6, C7, C8	Siemens B32231	Capacitor, Mylar, .1uF 250V
C3, C4	Philips 431CRH1650+1650	Capacitor, Electrolytic 3300uF 63V
C9, C10	Siemens B41010	Capacitor, Electrolytic 470uF 40V
Q1, Q2	Motorola MJ802	Transistor, Silicon NPN
CR1, CR2, CR3, CR4	Motorola MR504	Diode, Silicon
CR6, CR7	Gen. Inst. IN5060	Diode, Silicon
CR5, CR6	Dialco 559-0101-003	Diode, Light Emitting
-----	Dialco 515-0003	LED Mounting Collar
K1	P & B R10-E1-W2-V700	Relay, 2C, 24V 10A contacts
-----	Allied 30054-1	Socket, Relay
-----	Allied 30040-1	Retaining Spring, Relay
T1	McCurdy MRI-45-4018	Transformer, Power
SW1	JBT ST22K	Switch, Power
F1	Littelfuse 313002	Fuse, 2A 5B
-----	Littelfuse 342-004	Fuseholder
-----	Elco 00-6024-018-940-028	Connector, PC Edge
-----	Amphenol 26-4101-24P	Connector, 24 pin
-----	Mallory VR3	Clamp, Capacitor mounting
-----	Thermalloy 8113PF603	Socket, Transistor
-----	Thermalloy 8903NB	Cover, Transistor, Black
-----	McCurdy PS854-1	PC Assembly, regulator
-----	McCurdy PS854-2	PC Assembly, control

6.02 List of replaceable parts, PS854-1 regulator assembly.

<u>REFERENCE DESIGNATION</u>	<u>SUPPLIER and PART NUMBER</u>	<u>DESCRIPTION</u>
R13, R14	Beckman 91AR500	Potentiometer, 500 ohm
C1, C2, C7, C8	Siemens B32540	Capacitor, Mylar .1uF, 100V
C10	Erie 835024Z5F47010100	Cer. Disc 470pF $\pm 10\%$

6.02 List of replaceable parts, PS854-1 regulator assembly.

<u>REFERENCE DESIGNATION</u>	<u>SUPPLIER and PART NUMBER</u>	<u>DESCRIPTION</u>
C5, C6	ITT TAG1M35	Capacitor, Tantalum 1uF 35V
C3, C4	Siemens B41283	Capacitor, Electrolytic 470uF 40V
CR1, CR2	Motorola MZ2361	Diode, Silicon Reference
CR7, CR8	Philips IN4148	Diode, Silicon
CR5, CR6	Motorola IN825A	Diode, Zener
CR9, CR10	Motorola IN4748A	Diode, Zener
CR3, CR4	Motorola IN5257B	Diode, Zener
IC1, IC2	Motorola MC1741CP1	Integrated Circuit
T1	830802	Socket, Integrated Circuit, 8 pin
Q3, Q5	Motorola MPSA06	Transistor, Silicon NPN
Q4, Q6	Motorola MPSA56	Transistor, Silicon PNP
Q1, Q8	Motorola 2N5679	Transistor, Silicon PNP
Q2, Q&	Motorola 2N5681	Transistor, Silicon NPN
-----	Thermalloy 2257	Heatsink, T05

6.03 List of replaceable parts, PS854-2 control assembly.

<u>REFERENCE DESIGNATION</u>	<u>SUPPLIER and PART NUMBER</u>	<u>DESCRIPTION</u>
C3, C4	Siemens B32540	Capacitor, Mylar, .1uF 100V
C11	ITT TAG1M35	Capacitor, Tantalum 1uF 35V
C1, C2, C7, C8, C9, C12	ITT TAG3.3M35	Capacitor, Tantalum 3.3uF 35V
C10	ITT TAG10M25	Capacitor, Tantalum 10uF 25V
C5, C6	Siemens B41283	Capacitor, Electrolytic 100uF 25V
CR1, CR13	Motorola M22361	Diode, Silicon Reference
CR9, CR10, CR11, CR14	Philips IN4148	Diode, Silicon
CR2	Gen. Inst. IN5060	Diode, Silicon
CR3	Motorola 2N5062	Thyristor
CR6, CR7	Motorola IN4743A	Diode, Zener
CR8, CR12, CR15, CR16	Motorola IN5240B	Diode, Zener
CR4, CR5	Motorola IN5255B	Diode, Zener
IC1	RCA CA31307	Integrated Circuit

6.03 List of replaceable parts, PS854-2 control assembly

REFERENCE DESIGNATION	SUPPLIER and PART NUMBER	DESCRIPTION	REFERENCE DESIGNATION
IC2	Motorola MC1458CP1	Integrated Circuit	IC2
Q6,Q7,Q8	Motorola MPSA06	Transistor, Silicon NPN	Q6, Q7, Q8
Q2,Q4,Q5	Motorola MPSA56	Transistor, Silicon PNP	Q2, Q4, Q5
Q3	Motorola MPSL01	Transistor, Silicon NPN	Q3
Q1	Motorola 2N5679	Transistor, Silicon PNP	Q1
Q9	Motorola MBS4992	Bidirectional Switch	Q9
-----	Thermalloy 7717-245	Transistor Pad, T05 to	-----
-----	Thermalloy 2257	Heat sink, T05	-----
-----	TI 830802	Socket, Integrated Circuit, 8-Pin	-----
		Motorola MPSA06	Q3, Q4
		Motorola MPSA56	Q2, Q4, Q5
		Motorola 2N5679	Q1
		Motorola 2N5681	Q2, Q3
		Thermalloy 2257	-----

6.03 List of replaceable parts, PS854-2 control assembly

REFERENCE DESIGNATION	SUPPLIER and PART NUMBER	DESCRIPTION
CR1, CR4	Siemens B2344	Capacitor, Mylar
CR11	ITT TAG3.3M35	Capacitor, Tantalum
CR1, CR2, CR3, CR7, CR8, CR12	ITT TAG3.3M35	Capacitor, Tantalum
CR10	ITT TAG10M25	Capacitor, Tantalum
CR5, CR6	Siemens B4128	Capacitor, Electrolytic
CR1, CR13	Motorola M23361	Diode, Silicon
CR2, CR10, CR11, CR14	Phillips 1N4148	Diode, Silicon
CR2	Gen. Inst. IN5050	Diode, Silicon
CR3	Motorola 2N5082	Thyristor
CR6, CR7	Motorola 1N4733A	Diode, Zener
CR8, CR12, CR15, CR16	Motorola 1N5210	Diode, Zener
CR4, CR5	Motorola 1N5257	Diode, Zener
IC1	ACA CA31307	Integrated Circuit

CONSOLE TYPE SS 7650
 CONSOLE NO. D101011
 CUSTOMER KYU11
 PROJECT NO. 800558A

McCURDY RADIO TEST REPORT
 SHEET NO. 2 OF 2
 DATE 15-5-81
 TESTED BY. M. AHMED

INPUT		O/P		SIGNAL ROUTING			FREQUENCY RESPONSE REFERENCE 1KHZ				% DISTORTION AT 10dB ABOVE NORMAL LEVEL				I.M DIST	I/P NO-ISE	S/N RAT-10		
#	BRIDGING	LEV	-EL	IN	TO	TO	TO	20 HZ	30 HZ	15 KHZ	20 KHZ	20 HZ	30 HZ	1 KHZ	15 KHZ	20 KHZ	%	dBm	dB
0	600	+8		CH 13R	A30 P. SUM AMP	-	PSM R		-0.1	-0.5			.1	.1	.1				86
0	600	+8		CH 14L			AUD L	/	-0.6				.1	.1	.1				79
0	600	+8		CH 14R			AUD R	/	-0.8				.1	.1	.1				79.5
0	600	+8		CH 15L	A29 P. SUM AMP		PSM L	+0.2	-0.5				.1	.1	.1				86
0	600	+8		CH 15R	A30 P. SUM AMP		PSM R	+0.1	-0.6				.1	.1	.1				86
0	600	+8		CH 16L			AUD L	/	-0.8				.1	.1	.1				78

CONSOLE TYPE

SS 7650

MCCURDY RADIO TEST REPORT

CONSOLE NO.

D101011

SHEET NO. 1 OF 2

CUSTOMER

KYUU

DATE 15-5-81

PROJECT NO.

800558A

TESTED BY. M. AHMED

PUT		O/P	SIGNAL ROUTING				FREQUENCY RESPONSE REFERENCE 1KHZ					% DISTORTION AT 10dB ABOVE NORMAL LEVEL					I.M DIST 4:1	I/P NO-ISE	S/N RAT-10
* BRIDGING	LEV	-EL	IN	TO	TO	TO	20 HZ	30 HZ	15 KHZ	20 KHZ	20 HZ	30 HZ	1 KHZ	15 KHZ	20 KHZ	%	dBm	dB	
	-60	150	+8	CH 1	AUD L			-0.8	-0.8			.19	.1	.1			124		
	-60	150	+8	CH 2	A29 PGM SUM.	PGM L A31		-0.7	-0.7			.1	.1	.11			125		
	-60	150	+8	CH 3	A30 P.SUM AMP.	PGM R A32		-0.6	-0.5			.1	.1	.12			125		
	-60	150	+8	CH 4	AUD R			-0.7	-0.5			.1	.1	.1			124		
	0	600	+8	CH 5L	A29 PGM S. AMP	PGM L		/	-0.5			.17	.1	.1				85	
	0	600	+8	CH 5R	A30 P.SUM AMP.	PGM R		/	-0.5			.1	.1	.1				85	
	0	600	+8	CH 6L		AUD L		/	-0.7			.1	.1	.1				79	
	0	600	+8	CH 6R		AUD R		/	-0.7			.1	.1	.1				79	
	0	600	+5	CH 7L	AUD L	MONO A SUM 35		-0.1	-0.1			.1	.1	.17				77	
	0	600	+5	CH 7R	AUD R	"		-0.1	-0.1			.1	.1	.14				77	
	0	600	+8	CH 8L	A29 P.SUM AMP	PGM L		-0.1	-0.5			.11	.1	.1				86	
	0	600	+8	CH 8R	A30 P.SUM AMP.	PGM R		-0.1	-0.5			.1	.1	.1				86	
	0	600	+8	CH 9L		AUD L		-0.1	-0.7			.1	.1	.1				79	
	0	600	+8	CH 9R		AUD R		/	-0.7			.1	.1	.1				79	
	0	600	0	CH 10L	AUD L	A36 CR MON L		-0.1	-0.8			.14	.1	.13				-80	
	0	600	0	CH 10R	AUD R	A37 CR MON R		-0.1	-0.8			.14	.1	.1				-80	
	0	600	+8	CH 11L	A29 P.SUM AMP.	PGM L		-0.1	-0.5			.12	.1	.1				86	
	0	600	+8	CH 11R	A30 P.SUM AMP.	PGM R		-0.1	-0.5			.1	.1	.1				86	
	0	600	+8	CH 12L		AUD L		/	-0.8			.1	.1	.1				79	
	0	600	+8	CH 12R		AUD R		/	-0.8			.1	.1	.1				79	
	0	600	+8	CH 13L	A29 P.SUM AMP.	PGM L		/	-0.5			.11	.1	.1				86	