



# LPB<sup>®</sup>

## Signature II

### 10 MIXER DUAL STEREO CONSOLE



MODEL  
S-20

- 30 Inputs • Step Attenuators • Plug-In Modules • Led Peak Indicators • Switch Selectable Mic Gain •
- All Transformer Inputs and Outputs • Demonstrated RF Immunity • Prewired for Simulcast Option •

The LPB Model S-20 10 Mixer Dual Stereo Console accepts a total of 30 transformer coupled audio inputs, 3 to each of the 10 mixers. As shipped, mixer 1 accepts 3 switched stereo microphone inputs and mixers 2 through 10 accept 3 switched stereo high level inputs each. Mixers 2 through 4, however, can each accept 3 switched microphone inputs by substituting the standard plug-in high level input boards with available microphone preamp plug-ins. Monitor speaker muting and tally relays are provided for mixers 1 through 3, and mixers 4 through 10 incorporate remote switch contacts. Mixers 1 through 4 are internally switch selectable to mono or stereo, as well as mixer 10 which includes a talkback line.

A cue position is provided on every mixer and the S-20 includes an internal cue system consisting of a cue amplifier, level control and 5 inch speaker. A phone jack mounted on the rear panel provides headphone monitoring of program, audition and cue with its own level control. The internal stereo monitor amplifier is switch selectable to

monitor program, audition or an external line. The illuminated VU meters are switched simultaneously with the monitor selector in the program and audition positions and return to read the program line in the external position of the monitor selector.

The program, audition and optional mono mixdown performance specifications are identical, with the mono mixdown amplifier switch selectable to provide a mono sum of either the program or audition outputs. The program and audition outputs each have a master level control on the front panel, with the audition output being fed to a 3-position output director switch. Program, audition, headphone and cue buss auxiliary outputs are also provided. Light emitting diode peak level indicators are standard, located in the VU meters, and may be adjusted to fire at various level thresholds. All connections to the S-20 are made through barrier strip screw connections located within the console.



## SPECIFICATIONS

### Mixers

Total . . . . . 10 Stereo  
 With Cue . . . . . 10  
 Type . . . . . Step Attenuator

### Inputs

Standard Factory Equipped  
 Mic (Mono/Stereo) . . . . . 3  
 Hi-Level . . . . . 27  
 Optional Maximum  
 Mic (Mono/Stereo) . . . . . 12  
 Hi-Level . . . . . 30  
 Total . . . . . 30

### Input Impedance

Mic . . . . . 150 ohms source, Trans. Bal.  
 Hi-Level . . . . . 600 ohms, Trans. Bal.

### Input Levels

Mic . . . . . selectable: -45 dBm, -55 dBm, -65 dBm  
 Hi-Level . . . . . -10 dBm  
 Remote/Net . . . . . -10 dBm

### Outputs

Program (P1) . . . . . stereo, +8 dBm (Ovu), clipping level  
 above +22 dBm  
 Audition (P2) . . . . . stereo, +8 dBm (Ovu), clipping  
 level above +22 dBm  
 Opt. Mono Mixdown . . . . . +8 dBm (Ovu), clipping  
 level above +22 dBm  
 Monitor . . . . . 4 Stereo @ 12 watts per channel  
 Cue . . . . . 1 @ 1 watt with 5" Internal Speaker  
 Headphones . . . . . 1, switchable between Program,  
 Audition or Cue

### Output Impedance

Program . . . . . 600 ohms, Trans. Bal.  
 Audition . . . . . 600 ohms, Trans. Bal.  
 Opt. Mono Mixdown . . . . . 600 ohms, Trans. Bal.  
 Monitor . . . . . 2 to 8 ohms  
 Headphones . . . . . 200 ohms and up

### Frequency Response

Program . . . . .  $\pm 1.0$  dB 20 Hz – 20 kHz  
 Audition . . . . .  $\pm 1.0$  dB 20 Hz – 20 kHz  
 Opt. Mono Mixdown . . . . .  $\pm 1.0$  dB 20 Hz – 20 kHz  
 Monitor . . . . .  $\pm 1.5$  dB 20 Hz – 15 kHz

### Total Harmonic Distortion

Program, Audition, Opt.  
 Mono Mixdown . . . . . Typ. 0.2%, 0.5% Max.,  
 20 Hz – 20 kHz @ 18 dBm Output,  
 -55 dBm Input  
 Monitor . . . . . 1.5% Max., 20 Hz to 15 kHz

### I.M. Distortion

Program, Audition, Opt.  
 Mono Mixdown . . . . . Less than .15% @ +22 dBm  
 Output Level  
 Monitor . . . . . Less than 0.2% @ 12 watts

### Signal To Noise

Program, Audition, Opt.  
 Mono Mixdown . . . . . Better than 74 dB below +18 dBm  
 Output with -50 dBm Input  
 20 Hz – 20 kHz

### Crosstalk

Program to Audition  
 and Monitor . . . . . Below noise level

### Power Requirements

Voltage . . . . . 117 VAC (234 VAC available)  
 Frequency . . . . . 50/60 Hz  
 Power . . . . . 70 watts

### Dimensions

Width . . . . . 38-3/4"  
 Height . . . . . 9"  
 Depth . . . . . 15"  
 Weight . . . . . 60 lbs.

### Plug-In Modules

Types . . . . . Mic Preamp, Hi-Level Input, Line  
 Amp, Power Amp, Voltage Regulator  
 Total Number . . . . . 17

### Cabinet

Material . . . . . 0.125" Aluminum  
 Finish . . . . . Textured scratch resistant "champagne gray"  
 Armorhide® exterior, gold anodized interior

### Panel

Material . . . . . 0.125" Aluminum  
 Finish . . . . . Horizontally ground and brushed aluminum,  
 black epoxy silk screening with protective  
 clear epoxy overcoat.

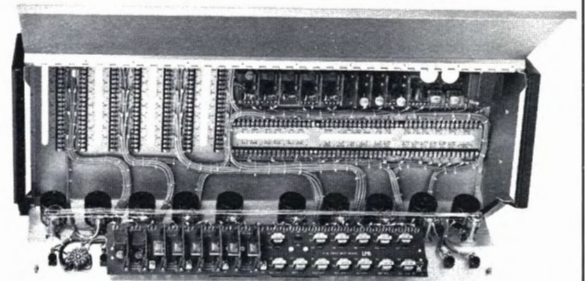
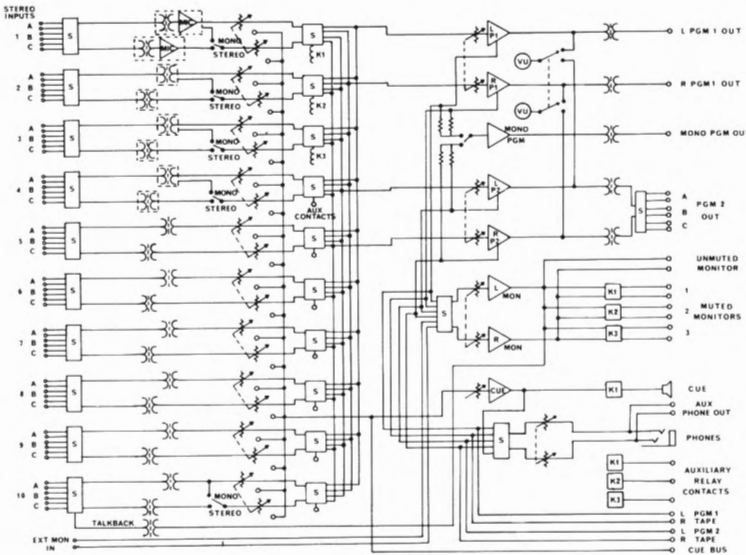

Model S-20 Console Interior

The S-20 Console top cover and front panel hinge open to allow immediate access to all circuit components and the labeled input/output screw terminals.



LPB Inc.

28 Bacton Hill Road, Frazer, Pa. 19355 (215) 644-1123