



**OPERATING & MAINTENANCE
INSTRUCTION MANUAL**

MODEL 705

FM / FMX™ STEREO GENERATOR



If You Didn't Get This From My Site,
Then It Was Stolen From...
www.SteamPoweredRadio.Com



INOVONICS
INCORPORATED

FMX
SYSTEM

USER'S RECORD

Model 705 - Serial No.
Date Purchased
Warranty Card Returned?
Purchased From

INSTRUCTION MANUAL

MODEL 705

FM / FMX™ STEREO GENERATOR

March, 1988

If You Didn't Get This From My Site,
Then It Was Stolen From...
www.SteamPoweredRadio.Com



1305 Fair Avenue - Santa Cruz, CA 95060

(408) 458-0552

TABLE OF CONTENTS

I	FUNCTIONAL DESCRIPTION	3
	Introduction - Audio Pre-Processing Require- ments - About FMX™ - Specifications - Block Diagram - Patent Notice	
II	INSTALLATION	9
	Unpacking and Inspection - Mounting - AC Power - RFI - LINE INPUT and Range Selection - Pre- emphasis Selection - COMPOSITE OUTPUT and Impedance Selection - Installation of FMX™	
III	SETUP AND OPERATION	13
	Panel Controls - Setup Procedure - Composite Equalization Adjustment	
IV	CALIBRATION	17
	Equipment Required - Visual Inspection - Strap- ping and Presets - Power-Up - Input Gain - Highpass Filter - Preemphasis - Filter Tuning - Overshoot Compensation Adjustment - Crosstalk Trim - FMX™ Plug-In Option Calibration - Final Level Setup	
V	CIRCUIT DESCRIPTIONS	24
	Input and Preemphasis Stages - Filter Overshoot Compensator - Lowpass Filter - Subcarrier and Pilot Generation - Output Amplifier - Power Supply - Plug-In Option for FMX™	
VI	APPENDIX	31
	Part Lists - Schematics - Warranty	

I FUNCTIONAL DESCRIPTION

Introduction

Inovonics' 705 is a full-featured FM Stereo Generator (or "Stereo Coder" in European parlance) which includes the FMX™ "coverage extension" transmission system as an easily-installed plug-in option. FMX™ was developed jointly by the Columbia Broadcasting System (CBS) and the U.S. National Association of Broadcasters (NAB). The system is discussed in more detail at the end of this section.

The 705 Generator incorporates the preemphasis and lowpass functions required in customary broadcasting practice and features patented compensation circuitry to avoid modulation sacrifices due to filter overshoots. FM subcarrier(s) and Pilot are digitally synthesized for optimum and adjustment-free operation. User adjustments have, in fact, been reduced only to those essential for system matching; INPUT, OUTPUT and PILOT levels. The one exception is a "COMPOSITE EQ" control which is preset at the factory for optimum stereo separation, but which may be readjusted to at least partially compensate for deficiencies in other parts of the transmission system.

Audio Pre-Processing Requirements

Though overmodulation protection circuitry is included in the 705, it is anticipated that the Generator will be preceded by some form of "audio processing" system which places a ceiling on program peaks with specific allowances for "protection" of the preemphasis characteristic. It is essential that this need for "split spectrum" audio processing be understood and met.

In FM broadcasting, a high frequency preemphasis (high-end boost) characteristic is imparted to the input program signal prior to transmission. At the receiver a complementary deemphasis (high-end rolloff) network restores overall flat frequency response. The purpose of this exercise is to reduce the high frequency noise inevitably added in transmission. This noise generally gets worse as the listener's distance from the broadcasting station increases.

If a low frequency tone (300Hz) is applied to the transmitter input at a level which yields 100% carrier modulation, a high frequency tone (10kHz) applied at the same level would over-modulate the carrier (400% or more) because of the preemphasis curve. Fortunately, normal voice and music program signals have comparatively low energy at the higher frequencies, and actual statistics of program spectral composition were taken into

account when the preemphasis characteristic was established years ago. Nevertheless, occasional high energy, high frequency peaks (sibilants, cymbals, etc.) can still cause carrier overmodulation, even when program peaks are broadband-limited to 100% modulation values. This is especially true when modern-day recordings of contemporary music are the program source.

A preemphasis network ahead of a broadband limiter, and a deemphasis circuit following it, will deal with this situation, though the overall level will "duck" whenever a high-end peak occurs. This imparts a "choppy" sound to the program and reduces both intelligibility and perceived loudness. What is instead required is a program limiter operating as a dual-band device with a broadband section to cope with normal program peaks and an independent high frequency limiter section (with proportionally faster time constants) to deal with those program components subject to accentuation by the transmission preemphasis characteristic. A limiter of this type (now common in FM broadcasting systems) has negligible audible effect on most program material, while it provides absolute protection from carrier overmodulation.

Overmod protection circuitry within the 705 takes the form of a complex, active peak clipper integral with the filter overshoot compensator. Because of its unique mode of operation, a good deal more peak clipping may be tolerated than with more simple signal clipping circuits. The 705 may, in fact, even be used "barefoot," or with minimal audio pre-processing, yet still yield quite acceptable and "competitive" performance.

About FMX™

FMX™ is the tradename for a patented, improved system of FM stereo broadcasting which is fully compatible with the customary standards and practices used throughout the world. This means that not only can FMX™ transmissions be received by existing mono and stereo receivers with no performance compromises, but a new generation of FMX™-equipped receivers can provide the broadcaster with a substantial increase in stereocasting coverage (up to 400% has been claimed by the inventors), nearly equalling the noise-free coverage of mono reception.

Development of the Inovonics 705 Stereo Generator was actually inspired by Torick and Keller's 1983 invention of FMX™ (U.S. Pat. 4,485,483), and the improvements it implied for the entire FM broadcasting industry. The Inovonics Generator was designed from the beginning to accept and support a plug-in circuit card for the FMX™ system, leaving the "whether" and "when" at the option of the individual broadcaster.

The FMX™ system employs a second, "quadrature" subcarrier at the same 38kHz as the regular L-R signal, but with a 90-degree phase offset. The additional subcarrier is modulated by

"compressed" L-R program information which is "expanded" in the FMX™ receiver for a much-improved signal-to-noise figure.

The compression transfer function (input vs. output) of the "quadrature" subcarrier (S') has a "reentrant" or dynamic inversion characteristic; that is, the level of S' reaches a maximum value then begins to drop (even as the input continues to increase) until it "shuts off" completely. S' shutoff is concurrent with maximum levels of the normal stereo subcarrier (S). Total modulation, including the L+R "mono" (M) component, (M + S + S') should never exceed the usual 100% value of the "interleaved" stereo signal. The FMX™ compression function is graphed in Figure 1.

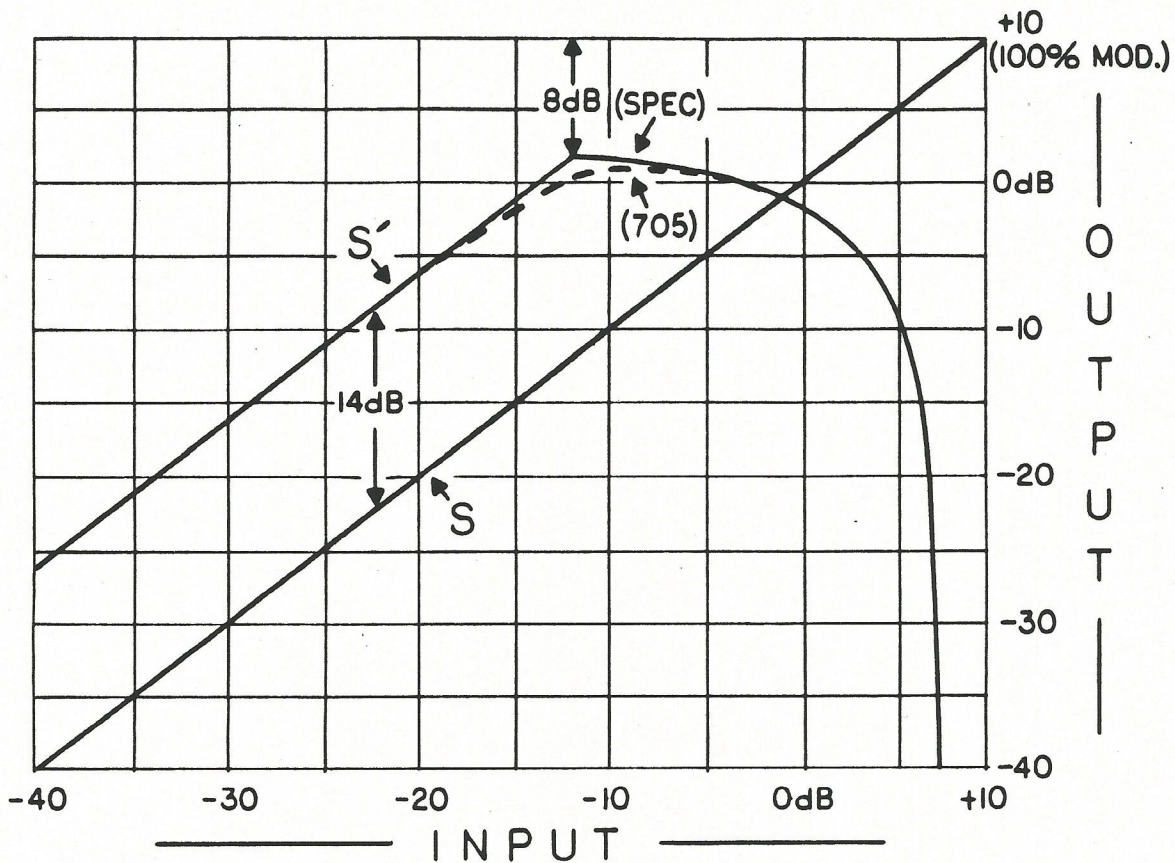

Figure 1 - FMX™ COMPRESSION CHARACTERISTIC
(S' compressor IN vs. OUT relative to S)

The FMX™ receiver has a dual demodulator which independently recovers program information from both the S and S' subcarriers. Because both signals are always available, "servo" techniques may be used in the complementary expansion process. This obviates the perfect tracking of levels and time constants demanded by most traditional compander schemes. Dematrixed and recovered Left and Right program channels are thus optimized for best S/N at low levels.

The FMX™ system is currently owned and licensed by Broadcast Technology Partners (BTP). It was re-engineered in 1987 to resolve certain technical issues which prevented universal acceptance by FM broadcasters and receiver manufacturers at the time of first introduction in 1986. The current plug-in-option circuit card available from Inovonics contains all updates as of the date of manufacture. Furthermore, since FMX™ circuitry may be user-installed in a matter of minutes, any future updates are very easily implemented.

Specifications

Frequency Response (preemphasis defeated):
+/-0.5dB, 25Hz-16kHz; -20dB or better
at 10Hz, -60dB or better at 19kHz.

Distortion: <0.1% THD in baseband and
subcarrier at 90% modulation.

Noise (below 100% modulation, Pilot OFF):
-75dB or better in baseband and
subcarrier; 38kHz residual and "digital"
noise above 54kHz, -60dB or better.

Stereo Separation: Better than 55dB, 25Hz-
5kHz; better than 50dB, 5kHz-16kHz.

Crosstalk (M/S or S/M): better than -60dB.

Pilot: 19kHz, +/-1Hz; <2% THD (distortion
products better than 55dB below 100%
modulation); Pilot injection level
adjustable between 6% and 12% relative
to 100% modulation.

Inputs (LEFT and RIGHT): Active-balanced,
bridging; accept line input levels
between -15dB and +15dB for 100%
modulation. (0dB = 0.775V r.m.s.)

Input Filtering: 7-pole, phase-corrected,
active-elliptic "FDNR" lowpass with
defeatable overshoot compensation
circuitry. Third-order Chebyshev
highpass section.

Preemphasis: Selectable for 75- or 50-
microsecond or "flat" transmission
characteristics.

Output: Single-ended (unbalanced); selectable 75-ohm or "zero" (voltage source) impedance. Level adjustable between -5 and +12dB (0.5-3V r.m.s. or 1.2-8V p-p).

Overmodulation Protection: Integral with input filter overshoot compensation circuit and defeatable with same.

Digital Synthesis Sampling Rate: 608kHz (16X subcarrier).

Option For FMX™: User-installable auxiliary plug-in circuit board with all parameters preset.

Power Requirement: 105-130 or 205-255VAC, 50/60Hz; 8 Watts.

Size and Weight: 1-3/4" x 19" x 8" (1U); 8 lbs.

Block Diagram

A simplified block diagram of the 705 Stereo Generator is shown on Page 8. Generator circuitry is explained in detail under Circuit Descriptions, Section V, which reference the complete set of schematic diagrams contained in the Appendix, Section VI.

Patent Notice

Lowpass filter overshoot compensation circuitry employed in Inovonics' Model 705 Stereo Generator is covered by U.S. Patent No. 4,737,725.

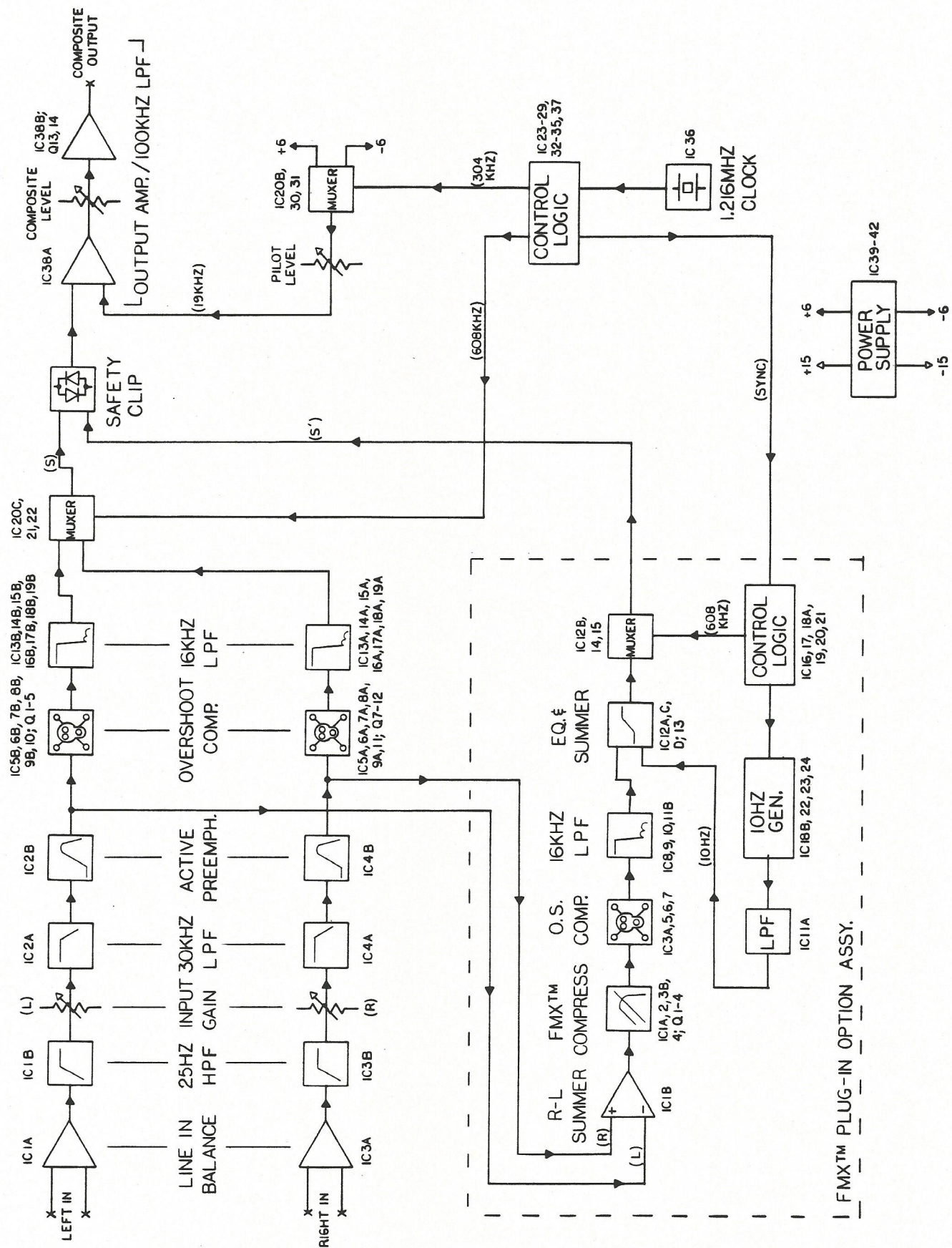

Figure 2 - BLOCK DIAGRAM, MODEL 705 STEREO GENERATOR

II INSTALLATION

Unpacking and Inspection

Upon receipt of the equipment, inspect carefully for shipping damage. Should any such damage be observed, notify the carrier at once; if not, proceed as outlined below. It is recommended that the original shipping carton and packing materials be saved should future reshipment become necessary. In the event of return for Warranty repair, shipping damage sustained as a result of improper packing for return may invalidate the Warranty.

IT IS VERY IMPORTANT that the Warranty Registration Card found at the front of this manual be completed and returned. Not only does this assure coverage of the equipment under terms of the Warranty, and provide some means of trace in the case of lost or stolen gear, but the user will automatically receive specific SERVICE OR MODIFICATION INSTRUCTIONS should they be issued by the factory.

Mounting

The Inovonics 705 is packaged to mount in a standard 19-inch equipment rack and requires only 1-3/4 inches (1U) of vertical rack space. The 705 generates negligible heat and, itself, is unaffected by wide variations in ambient operating temperature.

AC Power

Unless specifically ordered for export shipment, the 705 is delivered for operation from 125V, 50/60Hz AC mains. The back-panel designation next to the fuseholder will confirm both the mains voltage selected and the value of the fuse to be used.

Mains voltage reselection is easily made with the top cover removed. A plug-on jumper strip next to the power transformer may be installed in either of two positions for the two nominal mains voltages. A silkscreened legend next to the connector clearly indicates its orientation. A proper fuse must always be installed, and the appropriate back-panel voltage designation should be marked to indicate the input power requirement.

The detachable power cord supplied with the 705 Generator is fitted with a North-American-standard male connector. The individual cord conductors are supposedly color-coded in accordance with CEE standards: BROWN = "hot," BLUE = neutral, GREEN/YELLOW = earth ground. If this turns out not to be the case, we offer our apologies (cord vendors vary) and advise that U.S. color coding applies: BLACK = "hot," WHITE = neutral, GREEN = earth ground.

RFI

Though the 705 has been designed to operate in close proximity to broadcast transmitters, care should be exercised in locating the unit away from abnormally high RF fields.

In some installation situations an RF ground loop may be formed between the input or output cable shield grounds and the AC power cord ground. Use of a "ground-lifting" AC adapter should remedy the problem, though the chassis must ultimately be returned to earth ground for safety.

LINE INPUT and Range Selection

The Model 705 has electronically-balanced (transformerless), bridging (10k-ohms or greater) LEFT and RIGHT LINE INPUTS. These are brought out to the rear-panel barrier strip and include chassis ground connections for cable shields.

Should the equipment which feeds the Generator require output loading, 600-ohm terminating resistors may be placed across the 705 input terminals.

The 705 accepts "zero-reference" program input levels between -15 and +15dB (0dB = 0.775V r.m.s.). This 30dB input level range is divided into two, more manageable 15dB segments which correspond to the 15dB range of the INPUT GAIN controls.

There are two sets of dual jumper strips under the top cover, just behind the LINE INPUT barrier strip. Though the two positions for range selection "shunts" are clearly marked in the board legend ("H" for HIGH level, 0 to +15dB; "L" for LOW level, -15 to 0dB), Figure 3 shows the jumpering options. As shipped, the 705 is jumpered for HIGH level inputs.

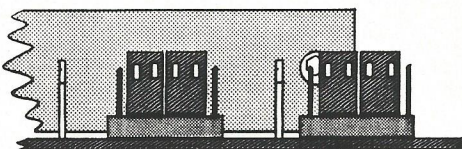

LOW LEVEL INPUTS
(-15dB to 0dB)

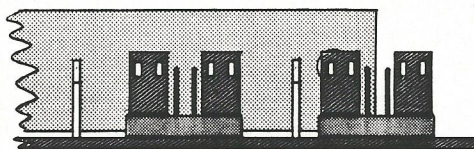

HIGH LEVEL INPUTS
(0dB to +15dB)

Figure 3

Preemphasis Selection

Both 75-microsecond (U.S.) and 50-microsecond (European) FM broadcasting preemphasis standards are readily accommodated. Two jumper strips, each with a shorting "shunt," are located under the top cover, just next to the LEFT and RIGHT INPUT GAIN controls. The "shunts" may be installed in either the "50" or the "75" (microsecond) positions as indicated in the circuit board legend. When the front panel PRE-EMPHASIS switch is ON, the selected characteristic is imparted to the input program signal. With the switch OFF, input signals are transmitted "flat," without preemphasis, as required for testing or when preemphasis is provided by preceding audio processing gear.

COMPOSITE OUTPUT and Impedance Selection

The single-ended, "unbalanced" COMPOSITE OUTPUT of the 705 is ground-referenced and has a "zero" impedance (voltage-source) output characteristic. A 75-ohm "buildout" resistance is provided, however, and may be placed in series with the Lo-Z output when the 705 is presented with complex reactive loads which might otherwise cause the output stage to become unstable.

A short coaxial cable "pigtail" runs from the rear-panel COMPOSITE OUTPUT jack to a connector strip located beneath the top cover, between the PILOT and COMPOSITE LEVEL controls. The end of the cable may be plugged onto the strip in either of two positions, labeled "LO-Z" and "75-OHMS" in the board legend. Figure 4 pictures the two impedance selection options. As shipped, the LO-Z output is routed to the rear panel jack.

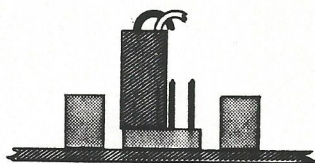

LOW-Z OUTPUT
(voltage-source)

Figure 4

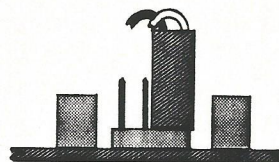

75-OHM OUTPUT
(series resistor)

Installation of FMX™

Whenever the 705 is used without the FMX™ option, a "dummy plug" must be kept in the FMX™ accessory socket. This plug turns off the FMX™ mode indicators and normalizes internal levels at the input of the subcarrier/pilot combining stage.

The FMX™ option circuit board is installed on the four threaded standoffs protruding from the main Generator board.

Remove the screws from the tops of the four standoffs and secure the FMX™ circuit assembly in place with components facing up and the ribbon cable "pigtail" to the left. Remove the "dummy plug" from the FMX™ accessory socket and insert the ribbon cable connector. The cable has been preformed, and there is only one way it can be plugged into the accessory socket.

This completes installation of the FMX™ option. Be sure to save the "dummy plug"; it can be stuck to the inside of the top cover with a length of masking tape.

III SETUP AND OPERATION

Panel Controls

A brief description of the various front panel controls and indicators is given here. The user is encouraged to at least skim this section, checking that terminology used here agrees with his understanding.

LEFT and RIGHT INPUT GAIN are adjustments to accommodate different program line levels. The controls have a 15dB range and cover inputs between -15 and 0dB, and between 0 and +15dB, depending on the position of the input gain range jumpers described on Page 10. (0dB = 0.775V r.m.s.)

The PRE-EMPHASIS switch turns ON and OFF the 75- (or 50-) microsecond preemphasis curve for both the LEFT and RIGHT program channels. Preemphasis is normally imparted by the Stereo Generator, and this switch is turned OFF only during testing, or in the unusual event that preceding audio processing equipment has a preemphasized (rather than a proper "flat") output response.

The OVERSHOOT CONTROL circuitry compensates for the natural and unavoidable property of all lowpass filters which results in output amplitude over-excursions even when a complex input signal has been pre-limited. This circuit establishes a maximum value for input signals and maintains this level for all program components, effectively eliminating the tendency of the filter to overshoot the amplitude constraint. The switch is turned OFF only for testing or as otherwise necessary to modulate the transmitter in excess of 100%.

LEFT and RIGHT INPUT CLIP indicators (red LEDs) light when the program input signal reaches the threshold of clipping (actually about 0.5dB into peak clipping), and FILTER COMP. indicators (green LEDs) show that correction is being applied to the signal for control of filter overshoots.

The COMPOSITE LEVEL control adjusts the level of the Stereo Generator output signal over the nominal range: -5 to +12dB (0.5 to 3.0V r.m.s., or 1.2 to 8V p-p). These figures are for the Lo-Z, "voltage source" output characteristic. When the 75-ohm buildout resistance is inserted, it may form part of a voltage divider and somewhat reduce the maximum level available.

PILOT LEVEL (pilot "insertion" level) is adjustable over a range of 6 to 12 percent, relative to 100% carrier modulation. The adjusted pilot percentage remains constant and does not require readjustment when the COMPOSITE LEVEL is changed.

The PILOT may be turned OFF independently of the subcarrier for certain tests. When the Pilot is OFF in the stereo mode, a red indicator lights. The switch is normally left in the ON position with a green LED indicating stereo operation.

The FMX™ option is switched ON or OFF by the appropriately labeled switch with its attendant LED indicators. When the option is not included with the 705, an FMX™ "dummy plug" is kept in the accessory socket to normalize levels and render the LED indicators inoperative regardless of switch position.

The MODE switch lights a green indicator during STEREO operation and enables the PILOT and FMX™ switch functions and indicators. When switched to MONO, all subcarrier and pilot signals are turned OFF, and the red indicator next to the switch is then the only one of that group which lights.

The POWER switch does, indeed, turn the 705 ON and OFF.

Setup Procedure

This setup procedure for the 705 Generator presupposes a simple installation with the Generator fed directly from the output of a properly adjusted audio processor. As explained on Pages 3 and 4, the processor should maintain program peaks at a ceiling value corresponding to 100% modulation, and incorporate "preemphasis protection" (independent high frequency) limiting in addition to broadband peak control.

The Procedure also assumes direct connection of the 705 output to the "composite" (broadband) input of the transmitter or exciter.

Variations from these conditions, such as an intermediate STL (microwave link) in either the input or output path of the 705, may require considerations not addressed here.

1. Double-check board jumpering for proper mains voltage, line input level range, preemphasis characteristic and composite output characteristic.
2. Set the 705 MODE switch to STEREO, PILOT switch ON, O-SHOOT CONTROL switch ON, and PRE-EMPHASIS switch ON.
3. Feed the audio processor LEFT channel input with a 500Hz sinewave test signal which yields 6 to 10dB of signal limiting. This should drive the processor line output to its "ceiling" value and present the 705 LEFT input with a signal representing 100% modulation of that channel.
4. Adjust the 705 LEFT INPUT GAIN control clockwise until the LEFT INPUT CLIP indicator comes on, then slowly back the control down (counterclockwise) until the indicator just goes out.

5. Shift the test tone to the RIGHT input of the audio processor and verify the same amount of peak limiting as for the LEFT. Repeat Steps 3 and 4 for the RIGHT channel of the 705.
6. Feed the processor with a typical stereo program signal.
 - A. The audio processor should indicate a normal amount of broadband peak and high frequency limiting.
 - B. It is normal for the LEFT and RIGHT INPUT CLIP indicators (red) to flash on program material, even though the input level is held at an absolute ceiling value. This is due to accumulated phase shifts in the 25Hz highpass and 30kHz lowpass input filters, as well as phase response differences between the 705 active preemphasis circuitry and that of the preemphasis protection limiter.
7. Observing the station Modulation Monitor, adjust the COMPOSITE LEVEL control for an indication of 100% modulation on program peaks.
8. Also with the aid of the Modulation Monitor, set the PILOT LEVEL for the desired injection level; typically, 8-10%.

Composite Equalization Adjustment (OPTIONAL)

Provision has been included in the 705 for limited equalization of the composite output signal. The adjustment is optimized at the factory for best stereo separation based on the "oscilloscope method" of measurement at the 705 COMPOSITE OUTPUT connector.

It is possible, however, to readjust the EQ to correct for other transmission system response deficiencies, either in the exciter input stages, in a Composite STL, or even in a lengthy cable run between the Generator and the transmitter.

If the frequency and phase response of the transmission system beyond the 705 Generator is known to be linear, it's best to leave the EQ adjustment alone! A procedure for this adjustment is, nonetheless, outlined here.

1. Remove the top cover of the Generator and locate the Composite Equalization Control, R188, the single-turn trim pot just to the left of the PILOT LEVEL control.
2. Turn the PRE-EMPHASIS, PILOT and FMX™ switches OFF. Feed a 1kHz sinewave signal to the LEFT input (only) of the 705 and adjust the signal level for about 90% modulation. It is important that there is no test signal leakage into the RIGHT input of the Generator.

3. With an oscilloscope, monitor the demodulated composite signal at the appropriate wideband output of the Modulation Monitor. A short length of coax should connect the Mod Monitor directly to the vertical input of the 'scope. Do not use a 'scope probe to monitor this signal, and be sure that the oscilloscope is known to be in proper calibration. Phase shift in the 'scope input circuitry will result in improper adjustment! It's best to externally trigger the 'scope timebase directly from the audio signal which feeds the LEFT input of the 705 to assure a more stable display of the demodulated composite waveform which should resemble Figure 5.
4. Increase vertical sensitivity of the 'scope to resolve "flatness" of the baseline. NOTE: some oscilloscopes will show erroneous distortion at the baseline when severely overdriven. Watch for an abrupt change at the baseline as the vertical sensitivity is progressively increased; ie: a change in flatness which does not correspond to a step increase in the vertical gain. Keep gain below such an overload point.
5. As R188 is rotated from one extreme to the other, the observed baseline should pass through a point of optimum flatness as depicted in Figure 6.
6. Increase the oscillator frequency to 15kHz and again check for baseline flatness. It should be possible to adjust R188 for a best flatness (separation) compromise at the two test frequencies.
7. Replace the top cover and return the Generator to normal operation. Don't forget to turn the PILOT, PRE-EMPHASIS and FMX™ (if used) switches back ON.

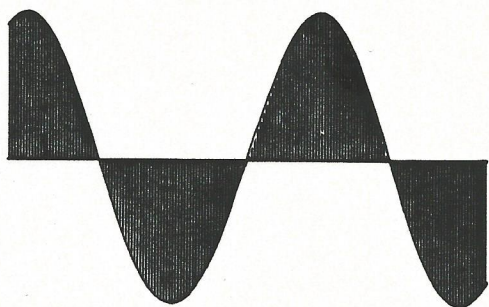

Figure 5

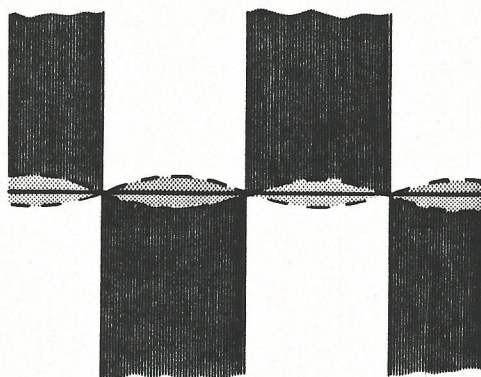

Figure 6

IV CALIBRATION

1. EQUIPMENT REQUIRED

- A. Dual Trace Oscilloscope; 2mV sensitivity, 20MHz bandwidth and two matched 10:1 probes.
- B. Audio Generator; 10Hz - 1Mhz, +20dB output capability with step and vernier attenuators.
- C. AC Voltmeter; 1mv (-60dB) sensitivity, 5MHz bandwidth.
- D. Frequency Counter; 1Hz - 10MHz range with 1Hz resolution.

2. VISUAL INSPECTION

- A. Inspect the board for general workmanship and to verify polarized components installed properly. All ICs should be facing the rear of the chassis.
- B. Check that the Voltage Selector is positioned for the mains supply to be used, and that an FMX^M "dummy plug" is inserted in the J1 socket.

3. STRAPPING AND PRESETS

- A. Set all front panel slide switches OFF and turn all front panel controls fully CCW.
- B. Center all single-turn circuit board trimpots.
- C. Move Input Gain Jumpers to "L" and Preemphasis Jumpers to "75"; Output Characteristic Selector to "LO-Z."

4. POWER-UP

- A. Turn POWER ON and check the +/-15 volt and +/-6 volt supplies. The left-hand end of the four diodes next to the regulator ICs are convenient test points.
- B. Monitor the "clock" at TP9 with a 'scope probe for a 12 volt p-p squarewave. Transfer the probe from the 'scope to the frequency counter and trim C57 for exactly 1216.000kHz. With the probe reconnected to the 'scope, turn POWER on and off several times to ensure that the clock starts every time without hesitation.

5. INPUT GAIN - HIGHPASS FILTER - PREEMPHASIS

- A. Monitor TP5 and TP6 with probes connected to the A and B channels of the 'scope. Apply a 1kHz oscillator signal at -10dB to both the Left and Right Line Inputs, single-ended, using the "+" terminals and Ground. The two 'scope traces should each show a 2 volt p-p signal.
- B. Observing the 'scope traces, momentarily short the "+" terminal of each input to its companion "-" terminal. In each case the waveform should disappear, indicating rejection of the induced common-mode signal.
- C. Reinstall the four Input Gain Jumpers in the "H" position. The 'scope waveforms should drop to 0.5 volts p-p. Repeat the "+" to "-" common-mode check.
- D. Superimpose the two 'scope traces to form a single apparent trace. If necessary, adjust one of the INPUT LEVEL controls to equalize amplitude, and trimpot R47 to equalize the phase between the two signals. Sweep the oscillator frequency upward from 1kHz; the traces should remain superimposed with flat amplitude response to about 12kHz (with filters unadjusted). Sweeping the oscillator frequency downward from 1kHz should show flat frequency and phase response to 25Hz, the amplitude dropping abruptly below 20Hz.
- E. Turn PRE-EMPHASIS ON and again sweep the oscillator upward from 1kHz. The traces should remain superimposed and increase to 2 volts p-p at 10kHz. With the oscillator set at 10kHz, change the Preemphasis Jumpers to "50"; the p-p amplitude should drop to 1.4 volts. Leave the Preemphasis Jumpers set for the transmission characteristic to be used, but turn PRE-EMPHASIS OFF for the remainder of checkout.

6. FILTER TUNING

- A. Apply a 1kHz, 0dB signal to both Line Inputs ("+" and Ground) and monitor TP5 and TP6 with the 'scope. Increase Left and Right INPUT GAIN for a 6 volt p-p waveform on each trace.
- B. Set the oscillator frequency to exactly 19,110Hz and adjust R118 and R141 for nulls in both channels.
- C. Set the oscillator to exactly 21,780Hz and adjust R124 and R147 for nulls.
- D. Set the oscillator to exactly 34,570Hz and adjust R112 and R135 for nulls.

7. OVERSHOOT COMPENSATION ADJUSTMENT (Continuation of FILTER TUNING procedure. Follows previous steps directly with identical setup.)
- A. Turn trimpots R55 and R83 fully CCW. Turn O-SHOOT switch ON and apply 100Hz to both inputs at a level that causes the two red INPUT CLIP LEDs to just come on. Balance INPUT GAIN controls for equal sensitivity.
 - B. Increase the oscillator output level by exactly 10dB. The monitored points should show squarewaves of about 8 volts p-p. Using the 'scope variable attenuators, set the two waveforms to exactly 3 divisions p-p with the top and bottom "flats" precisely on the graticule divisions.
 - C. Increase the oscillator frequency to about 3.1kHz, fine-tuning for maximum amplitude of the "double-hump" waveform(s). While continuing to fine-tune the oscillator frequency for maximum amplitude, adjust R47 and R75 so the the left-hand "hump" at the top of each trace is the same distance below the upper graticule division as the right-hand "hump" is above it.
 - D. Increase the oscillator frequency to 15kHz and adjust R55 and R83 for exactly 3 divisions p-p. FOLLOWING THIS, RESET 'SCOPE ATTENUATORS TO THEIR "CAL" POSITIONS.

8. CROSSTALK TRIM

- A. Connect the COMPOSITE OUTPUT of the 705 Generator directly to the vertical input of the 'scope using a short BNC-to-BNC cable. Apply a 1kHz, +10dB oscillator signal to both Line Inputs ("+" and Ground). Reduce the INPUT GAIN controls until the red INPUT CLIP LEDs just come on, then lower the oscillator output to +7dB. The COMPOSITE OUTPUT waveform should be a 0.8 volt p-p sinewave.
- B. With the MODE switch in STEREO, but with PILOT turned OFF, advance the COMPOSITE LEVEL for exactly 1 volt p-p. Fine-adjust one INPUT GAIN control to minimize "grass" (38kHz component) riding on the waveform.
- C. Reconnect the Line Inputs to feed the two channels out-of-phase. Jumper the "+" terminal of the Left Channel Line Input to the "-" terminal of the Right, and strap the "+" terminal of the Right Channel to Ground. The Composite Output should now show a 1 volt p-p, 38kHz DSB waveform modulated by the 1kHz input signal.

- D. Set the 'scope vertical sensitivity to 20mv/division and observe adjacent amplitude nulls of the modulation envelope. Fine-trim R47 to set the adjacent nulls on the same baseline.
- E. Increase the oscillator frequency to 10kHz and adjust the COMPOS. EQ. trimpot (R188) for best envelope amplitude null definition. Again set adjacent nulls on the same baseline, but with R112 and R135. Use R112 to correct for one-half the error and R135 for the rest of the correction.
- F. Feed the oscillator signal to the Left Line Input only ("+" and Ground). At 20mv/division 'scope sensitivity adjust the COMPOS. EQ. trimpot (R188) for a best compromise of baseline flatness at 1kHz and at 15kHz.

9. FMX™ PLUG-IN OPTION CALIBRATION

NOTE: If the 705 Generator does not include the optional FMX™ plug-in, skip this section and proceed to "FINAL LEVEL SETUP," Page 22.

Be sure the Generator used for calibration of the FMX™ plug-in has, itself, undergone calibration to this point in the Procedure.

- A. Visually inspect the plug-in circuit board for workmanship and orientation of polarized components. All ICs face the rear of the Generator except for the 24-pin CD4059 which faces left.

NOTE: Unless otherwise specified, all test points (TP1, TP3, etc.) and trimpots (R9, R57, etc.) refer to the FMX™ plug-in circuit assembly.

- B. Remove the FMX™ "Dummy Plug" and install the plug-in in the chassis. Apply power and recheck all four supplies. Monitor TP9 with a 'scope probe and verify a 10Hz sinewave at 15 volts p-p.

C. Compressor Alignment

- a. Monitor TP2 with the ACVM (TP2 and Ground). Disconnect the audio oscillator from any connection with the 705 Generator Line Input and feed a 1kHz signal directly to TP1 (TP1 and Ground). Adjust the oscillator level for a reading of -12dB on the ACVM.
- b. Move the ACVM monitor from TP2 to TP3 and adjust R29 for a meter reading of +1dB.
- c. Reconnect the ACVM to TP2 and adjust the oscillator output level for a meter reading of +10dB.

- d. Move the ACVM monitor from TP2 to TP3 and adjust R9 for a null (should be -55dB or so).
- e. Reconnect the ACVM to TP2 and adjust the oscillator output for a 0dB meter reading.
- f. Move the ACVM monitor from TP2 to TP3 and adjust R7 for a meter reading of -1.5dB.
- g. Repeat the above sequence to verify proper levels at all three output adjustments of the oscillator.

D. Filter Alignment

- a. Ground the "CD" terminal to defeat the FMX™ Compressor circuitry. Feed the oscillator to TP1 and monitor TP5 with the 'scope probe. Set the oscillator frequency to 1kHz and adjust the oscillator output level for a 1.5 volt p-p waveform.
- b. Reset the oscillator frequency to exactly 19,110Hz and adjust R57 for a null.
- c. Reset the oscillator frequency to exactly 21,780Hz and adjust R63 for a null.
- d. Reset the oscillator frequency to exactly 34,570Hz and adjust R51 for a null.
- e. Remove the ground strap from the "CD" terminal.

E. Overshoot Compensator Adjustment

- a. Feed the 1kHz oscillator signal to the Left Channel Line Input of the 705 Generator ("+" terminal and Ground). Monitor TP5 of the main 705 circuit board with a probe connected to Channel A of the 'scope. Monitor TP5 of the plug-in assembly with a probe connected to Channel B of the 'scope.
- b. Adjust the oscillator output level for a maximum amplitude waveform on 'scope Channel B, about 1.5 volts p-p. The waveform on Channel A of the 'scope should be about the same amplitude, but out-of-phase with Channel B.
- c. With the "ADD A & B" feature of the 'scope, and using both the 'scope variable attenuators and R32 on the FMX™ plug-in assembly, obtain a best null of the added signals.
- d. Reset the oscillator frequency to 15kHz, and using the 'scope vernier attenuator and R51 on the plug-in, obtain a best null.

- e. Adjust R39 for approximately the same resistance as R55 and R83 on the main Generator circuit board. This adjustment is not critical and can be made either by measuring the resistances with the low-voltage "ohms" function of a digital VOM, or simply by setting R39 for the same angular position as the two other pots.

10. FINAL LEVEL SETUP

- A. Set the MODE switch to MONO, the PILOT, FMX™ and PRE-EMPHASIS switches OFF, POWER and O-SHOOT COMP switches ON.
- B. Connect the COMPOSITE OUTPUT of the 705 Generator directly to the 'scope input and apply a 1kHz oscillator signal to both Line Inputs, in-phase ("+" and Ground, both inputs). Adjust the oscillator amplitude for a well-clipped COMPOSITE OUTPUT waveform and adjust the COMPOSITE LEVEL control for 2.8 volts p-p.
- C. Temporarily disconnect the oscillator signal and turn the MODE switch to STEREO and the PILOT switch ON. Adjust PILOT LEVEL for 0.25 volts p-p on the 'scope monitoring the COMPOSITE OUTPUT.
- D. Reconnect the 1kHz oscillator signal, and with the PILOT ON fine-adjust the COMPOSITE LEVEL control for a total p-p output amplitude of 3.0 volts.
- E. Set the oscillator output level to exactly +10dB. Set both INPUT GAIN controls so that the INPUT CLIP LEDs just come on. The COMPOSITE OUTPUT signal, "overshadowed" by the pilot, should just be showing signs of flattening on top and bottom with a p-p amplitude just under 3 volts.

IF EQUIPPED WITH THE FMX™ PLUG-IN OPTION:

- F. Turn the PILOT switch OFF and apply a 5kHz oscillator signal out-of-phase to the two Line Inputs of the 705 Generator (oscillator to Left Input "+" and Right Input "-", strap Right Input "+" to Ground). Defeat the normal subcarrier by grounding TP7 on the main Generator circuit board with a clip lead.
- G. Turn the FMX™ switch ON and adjust oscillator amplitude for a peak in the S' subcarrier. The p-p amplitude of the S' signal at the COMPOSITE OUTPUT should be 1.2 volts at its maximum amplitude.

- H. With the oscillator still set for Step G, remove the ground from TP7 on the main Generator circuit board and turn the FMX™ switch OFF. The normal subcarrier DSB amplitude should be 0.3 volts p-p.
- I. Remove the oscillator signal and turn the FMX™ switch back ON. Adjust R70 on the plug-in board for a 10Hz-modulated DSB (S') "FMX™ Pilot" signal of 0.03 volts p-p in the monitored COMPOSITE OUTPUT signal.

WHEN ALL LEVEL SETUP IS COMPLETE:

- J. Connect the COMPOSITE OUTPUT of the 705 Generator to a suitable Stereo / FMX™ demodulator, and with PRE-EMPHASIS turned ON test operation in all modes with actual program material.

V CIRCUIT DESCRIPTIONS

This section details the circuitry of the Inovonics 705 Stereo Generator, including that of the plug-in option card for the FMX™ coverage-extension system. The circuit discussions refer to the seven pages of Schematic Diagrams contained in the Appendix, Section VI.

In the case of identical circuitry in Left and Right program channels, the Circuit Description will reference the Left channel only.

Input and Preemphasis Stages (Schematic on Page 37)

IC1A is an active "balancing" stage for the Left program channel LINE INPUT. With the "H" terminals jumpered as shown, the unit accepts program levels between 0dB (0.775 volts r.m.s.) and +15dB, corresponding to 100% modulation. When the jumpers are moved to the "L" position, a portion of the input buildout resistance is shorted and program levels between -15dB and 0dB are accommodated.

IC1B combines a variable-gain amplifier with a third-order highpass filter. R11, the front-panel LEFT INPUT GAIN control, varies the input sensitivity of the unit over the 15dB ranges selected by the two input gain jumpering options. The highpass function has flat response down to 25Hz, but substantially attenuates subaudible components of the input program signal which could upset the AFC circuits in certain FM exciters.

IC2A is a third-order lowpass filter with flat response to about 20kHz. It was included to help cope with out-of-band "digital" noise present in the outputs of the many consumer-grade Compact Disc players which find increasing professional use.

IC2B is the "active" preemphasis stage which may be jumpered to impart either a 75-microsecond (U.S.) or 50-microsecond (European) transmission characteristic to the program signal when the front-panel PRE-EMPHASIS switch is ON. For certain system tests, switch S1 may be turned OFF for flat overall response.

Unlike a simple passive R/C preemphasis network, the active circuit does not give additional boost beyond the upper response limit. It exhibits the proper turnover and 6dB/octave rising characteristic, but only to about 18kHz. Instead of the response continuing to rise or merely "shelf," the stage becomes a second-order lowpass element with a 12dB/octave falling response past about 20kHz.

Filter Overshoot Compensator (Schematic on Page 38)

Any lowpass filter will exhibit a certain amount of "overshoot" and "ringing" at its output when presented with a complex input waveform. Generally, the sharper the cutoff the more pronounced the effect. Rather than a reflection on filter design, overshoots are attributable in large part to the expected and desired elimination of higher-order input signal components which, themselves, help to define the amplitude limits. A 7-pole "elliptic" filter, such as is used in the 705, can exhibit output overshoots in the order of 3dB or more, or 1.5 times the level of an amplitude-limited program input.

Unlike other systems of overshoot control which permit the filter to overshoot, then re-introduce the overshoots back into the signal path to mysteriously cancel themselves, the circuitry of the Inovonics 705 so conditions the amplitude-limited program signal that the filter, which is placed after the compensator, has little or no tendency to generate overshoots.

CR1 and CR2 form a "hard" clipper at the compensator input and are biased to a point which represents 100% modulation. Since this level is matched to the "ceiling" level of the final limiter in the audio processing system used ahead of the 705 Generator, the diodes rarely clip legitimate program waveshapes. They instead catch fast peaks which either have evaded the limiter or have been aggravated by phase shifts in the input and preemphasis stages.

IC6B is a phase-lag circuit which time-displaces the fast leading and trailing edges of steep waveforms. Thus the primary characteristic of a program waveform which would normally excite filter overshoots is instead added to the waveform amplitude. CR3 and CR4, also biased to the 100%-modulation reference, "strip" these displaced-and-added components from the program signal. They are subsequently recovered by IC8B, a differential, unity-gain amplifier monitoring the "stripper" input and output. These components, which contain much of the harmonic content of the audio program, are recombined with the "stripped" program signal in summing stage IC9B, but in opposite phase. This 180-degree displacement of certain higher-order program harmonics is not discernable to the listener, but is quite effective in inhibiting filter overshoots.

The DC bias representing 100% modulation is derived from the +15V supply by voltage divider R101/R102. CR9 is included to track (and compensate for) the temperature characteristics of the clipping diodes. IC12B buffers the +DC bias for positive-peak clipping, and inverter IC12A provides -DC bias for negative peaks. When the O-SHOOT COMP switch, S2, is turned OFF, R103 is added to the divider string. This increases the reference voltage to a level which effectively biases the compensation circuitry out of operation.

IC10A is a differential amplifier monitoring the CR1/CR2 input clipper. Its output consists of signal "clippings" at high gain. These are rectified by Q1 and Q2 to turn on Q3 which drives I3, the red L. INPUT CLIP indicator. C28 "stretches" the indicator "on" time so that clipping of even very fast peaks is adequately displayed. Similarly, IC10B amplifies the output of "recovery" stage IC8B to drive the green L. COMP. indicator, I4.

Lowpass Filter (Schematic on Page 39)

The 7-pole, elliptic-function (Cauer) lowpass filter is an active version of the classic L/C design. This configuration is frequently called the "FDNR" because each of the legs to ground simulates a Frequency-Dependent Negative Resistance. With reference to the L/C design upon which this active circuit is based, the resistors in series with the signal path directly replace series inductors, and each of the active circuits to ground replaces an inductor/capacitor series resonant element.

For an in-depth discussion of this and other useful filter information, the reader is directed to the "cookbook" which aided this design: the Electronic Filter Design Handbook by Arthur B. Williams, published by McGraw-Hill. In his book, the "FDNR" filter is called a "GIC," or Generalized Impedance Converter. Whatever!

IC19B buffers the output of the lowpass filter and provides gain to make up filter loss. The signal level at TP5 corresponding to 100% modulation is about 8V p-p.

Subcarrier and Pilot Generation (Schematic on Page 40)

The filtered Left and Right channel program signals are fed to the ends of resistor string R153-R161. CMOS analog transmission gates (ICs 20, 21 and 22) consecutively sample each tap, from one end to the other and back again, at a 38kHz rate. Resistor values are scaled for sinusoidal commutation between the two program channels. This generates a segmented Double Sideband Suppressed Carrier (DSB) FM subcarrier signal of high spectral purity for the L-R "difference" program information. The 608kHz sampling component (38kHz X 16 samples) is easily removed by a simple output filter.

The 19kHz Pilot signal is similarly generated by sinusoidal sampling. In this case the resistor string (R164-R171) is tied across the bipolar 6V supply and sampled at one-half the subcarrier rate. The output is a 19kHz segmented sinewave with a 304kHz sampling component. Since the Pilot represents only about 10% of total Composite modulation, the 304kHz component will be sufficiently attenuated by the simple filter included for the higher-order subcarrier component.

The 1.216MHz crystal "master clock" (IC36) is twice divided by IC37 to generate the 608kHz and 304kHz sampling frequencies for the subcarrier(s) and Pilot, respectively.

The CMOS transmission gates which sine-sample the stereo program signal (ICs 20, 21 and 22) are controlled by two cascaded 4-bit shift registers, ICs 23 and 24. C55 initiates a power-on reset pulse from IC25A to clear both registers and to set IC25B. This forces a Left-direct sample by IC20C. IC25B also loads a digital "1" into the SR (Shift Right) input of IC23, and sets IC26B to establish the S0 (Left toward Right) shift direction. Subsequent 608kHz pulses applied to the C (Clock) inputs of ICs 23, 24 and 25B will reset IC25B and shift the "1" from Q0 toward Q3, sequentially closing the next four transmission gates. As the "1" leaves the Q3 output of IC23, it is applied to the SR input of IC24 and continues to shift toward the Right program channel. When the "1" reaches Q3 of IC24 (full-Right) it resets IC26B to reverse the shift direction of both registers to S1 (Right toward Left). On its way back toward the Left channel, the "1" leaves the Q0 output of IC24 and enters the SL (Shift Left) input of IC23. Once it reaches the Q0 output of IC23, the "1" is combined with the S1 shift direction command by IC27C to set IC25B on the next clock pulse and restart the entire sequence.

With the MODE switch (S3) in MONO, ICs 28C and 29A interrupt clock pulses to the shift registers the next instant the circulating "1" reaches the Q3 output of IC23. This stops the sine-sampling at precisely the center of the resistor string and yields an L+R (MONO) output.

The stereo Pilot signal is generated in an identical manner, except that clocking is at the 304kHz rate.

Subcarrier and Pilot sampling must not only be synchronized, but properly phased with the subcarrier sample centered within the double-width Pilot sampling period. The 304kHz is thus divided from the 608kHz -Q output of IC37B to offset the Pilot sample by one-half of one subcarrier sampling period.

When subcarrier sampling is Left-to-Right (Q of IC26B high), and reaches the step just prior to "center" (Q2 of IC23 high), IC29C and D gate the next 304kHz clock pulse to binary divider IC35A. Thus every other time the subcarrier reaches this state, IC34A generates a momentary set pulse for IC34B, presetting the Pilot to its positive peak excursion and setting-up the shift registers for sequential sampling as already described.

This subcarrier-coincidence Pilot preset initiates the Pilot sampling sequence one-half of one 608kHz clock period before a subcarrier midpoint sample. The momentary reset from IC34A sets the 304kHz divider (IC37A) to ensure proper phase of the Pilot clock.

When the Pilot is switched OFF with S4, 304kHz clock pulses are gated off by ICs 27D and 28A at the next Pilot zero-crossing.

Output Amplifier (Schematic on Page 41)

The Pilot, the "normal" subcarrier (S) and the FMX™ subcarrier (S') signals are combined at the input of IC38A. S and S' are added at a "pre-pilot-insertion" clipper (CR11 and CR12) which is biased to the 100%-modulation level. Because of filter overshoot compensation circuitry employed in Left, Right and S' channels, the clipper is rarely required to act on normal program material. Nevertheless, under some conditions in the addition of S and S', overshoots can occur which then necessitate either a compromise in total carrier modulation or some form of peak control based on total subcarrier waveform amplitude.

IC36A and B comprise a fourth-order lowpass filter with quite flat frequency response to about 100kHz, and very good phase response to at least 60kHz. This filter removes the 608kHz subcarrier sampling component, and attenuates the 304kHz Pilot samples to a tolerable level. Q13 and Q14 deliver the high current drive for the COMPOSITE OUTPUT which can assume either a very LO-Z "voltage source" characteristic, or include a 75-OHM series buildout resistance for complex reactive loads which might drive this stage nuts.

Power Supply (Schematic on Page 41)

A circuit board jumper makes either parallel or series connection to the T1 power transformer primaries for 115- or 230-volt AC mains. "Three terminal" IC regulators supply the four regulated DC voltages. Program signal stages utilize bipolar 15 volts, and CMOS digital circuitry operates from a bipolar 6-volt supply to accommodate ground-referenced program signals sampled by the digitally-controlled CMOS analog transmission gates.

Plug-In Option for FMX™ (Schematics on Pages 42 and 43)

The FMX™ Compressor uses two J-FETs in a feedforward configuration based on the "Santana" FET gain-control circuit. This circuit, originally described by Henry Santana of Hewlett-Packard, is capable of voltage-linear gain reduction at levels considerably above those normally tolerated by traditional FET attenuators.

In the original circuit, two matched FETs are employed; a "control" FET between the inverting input of an op-amp gain stage and ground, and a matching "dummy" FET from the non-inverting input to ground. This second FET is biased fully "on" and also presented with the input signal through an identical input resistor. The "dummy" FET compensates for channel non-linearities and temperature characteristics of the "control" FET for near-perfect voltage-variable resistor performance.

In Inovonics' FMX™ Compressor variation, Q1 and Q2 are the "control" and "dummy" FETs, respectively. Left and Right program signals from the preemphasis stages are so summed by IC1B to derive an R-L program "difference" signal. This is fed to the Santana circuit and to a "precision" full-wave rectifier. IC2A and B deliver complementary-phase difference signals to rectifiers CR3 and CR4. CR1 and CR2 are included to compensate for the forward drop of the rectifier diodes.

The complex attack/release characteristics called out in the FMX™ Specification are provided by Q3, Q4 and associated circuitry. The 2-second, low level time constant is solely a function of R16, R17 and C2. The R19/20/22 divider (and V_{BE} of Q3 and Q4) establishes thresholds for the other time constants.

As the rectified difference signal reaches the turn-on of Q3, C2 charges through R23 for the 20ms attack, and discharges back through R23 and the parallel combination of R16 and R18 for the 200ms release. At a slightly higher level, Q4 turns on to charge C2 through R24 for the 1.5ms attack.

The difference-derived negative potential across C2 is buffered by IC3B and summed with a positive DC reference from CR7. This makes the output of IC4B a fixed negative voltage which is driven positive by the rectified difference signal. IC4A forms an active "clamp" to keep the output of IC4B from going at all positive, even as the difference signal continues to increase. R29 scales the control DC to the pinch-off voltage of the particular FETs used, also setting the FMX™ Compression Threshold.

Transfer characteristics of this feedforward circuit would be more abrupt than the specified "reentrant" function were it not for the R7/R8 series component at the Santana input. By adjusting R29 and R7, both the Threshold and the "shape" of the reentrant curve can be fit to specified parameters. R9 is a balancing control trimmed for maximum attenuation when Q1 is fully on.

A level of +10dB at the Compressor input (TP2) represents 100% L-R modulation. IC1A has a 14dB (inverting) gain below reentrant compression; this is the specified 14dB offset between the S and the S' signals. The Compressor output (TP3) is also scaled for a +10dB equivalent of 100% L-R modulation, but S' only reaches a maximum level of about +1.5dB at this point due to the reentrant characteristic. This +1.5dB is a bit short of the +2dB output (8dB below 100% modulation) called for in the Specification, and is due to the "soft knee" feedforward transfer function which has the S' signal slightly into compression at the nominal threshold value. (See Figure 1 on Page 5.)

The FMX™ Specification calls for a "hard" peak clipper set a few dB above the output ceiling of the Compressor. This requirement is met by CR8 and CR9, the input clipper of the

filter overshoot compensator. The S' compensator and filter circuits are identical to those in the Left and Right program channels which were discussed on Pages 25 and 26.

The S' filter buffer stage, IC11B, has unity gain. Filter loss makeup gain is provided by IC13A. The network between IC11B and IC13A has two functions; R67, R68 and C14 perform the specified S' low-end "shelving" equalization to reduce low frequency program components, and C15 bridges R60 to equalize phase response and compensate for time delay introduced in the S' channel by the additional Compressor stage.

The 10Hz FMX™ Pilot is derived from the 1.216MHz master clock. IC24, a programmable divider, is set to divide the clock by 20,480 for an output of 60Hz. ICs 18B, 22 and 23 reduce this to 10Hz and 30Hz symmetrical squarewaves. These are phased and combined to effectively subtract the 30Hz third harmonic from the 10Hz signal. IC11A is a simple 3-pole lowpass filter which supplies a quite pure 10Hz Pilot sinewave.

To be perfectly honest, the FMX™ Pilot is not exactly 10Hz. Rather, it is an even-numbered division (1,920) of the 19kHz Stereo Pilot, or 9.8958333Hz. This "error" was purposely introduced to support the phase-lock Pilot recognition circuits of some FMX™ receivers.

The 10Hz Pilot is combined with the S' signal at the input of IC13A. The output of this stage feeds one end of the S' subcarrier sine-sampling resistor string, and an inverted S' signal from IC13B feeds the other end. Logic for S' sine-sampling is identical to that for the main subcarrier described on Pages 26 and 27.

The 90-degree offset between S and S' is maintained by synchronizing logic gated by ICs 20A, 20C, 21C and 21D. IC19A is set when the main subcarrier reaches the midpoint in its sequential sampling between Right and Left program channels. At this S midpoint, S' is forced to begin its sampling sequence between R-L and L-R.

When the FMX™ switch, S5, is turned OFF, 10Hz Pilot and S' audio are removed from the input of IC13A, and S' logic stops the sampling sequence at the S' midpoint.

VI APPENDIX

(Parts Lists - Schematics - Warranty)

PARTS LIST - INOVONICS MODEL 705

(FM STEREO GENERATOR)

SCHMATIC DESIGNATION	INOVONICS PART NO.	COMPONENT DESCRIPTION (MFGR. / MFGR. P/N)
-------------------------	-----------------------	----------------------------------------------

Capacitors

UNLESS NOTED BELOW, capacitor values are per schematic notation in microfarads (uF), except when followed by "P" denoting picofarads (pF).

Values under 470pF are DM-15 (or CM-05) Mica type, 5% tolerance, 600V; manufacturer open.

Values from 470pF through .47uF are polyester ("Mylar") or polycarbonate film type, 5% tolerance, 63V or better; WIMA "MKS" or "FKC" series, Thompson "IRD" series, or equivalent "minibox" format with 0.2-inch lead spacing.

C7,20,34-40, 42-49,51	1086	Polypropylene; .0033uF, 2.5%, 100V (WIMA / FKP-2)
C33,52,53,59, 60,68,69,71, 72,74,75	1088	Electrolytic, High-Reliability; 2.2uF, 50V (ILLINOIS CAP. / 225RMR050M)
C41,50,61	1060	Electrolytic; 4.7uF, 25V (open, radial)
C57	1005	Variable; 5-50pF (MOUSER / 24AA024)
C70,73	0902	Electrolytic; 1000uF, 35V (open, axial)
C76,77	1064	Disc Ceramic; .005uF, 1KV (open)

Diodes

CR1-10,13-16	1100	Silicon Signal; 1N4151 (open)
CR11,12	1127	Silicon Schottky; 1N5711 (H.P., TRW)
CR17-24	1125	Silicon Rectifier; 1N4005 (open)

Indicators

I1,8,10,12	2021	LED, Clear/Green, T1 (STANLEY / SBG 3901)
I2,7,9,11	2022	LED, Clear/Red, T1 ((STANLEY / SBR 3901)
I3,5	2023	LED, Clear/Red, T1-3/4 (STANLEY / SBR 5701)
I4,6	2024	LED, Clear/Green, T1-3/4 (STANLEY / SBG 5701)

705 PARTS LIST (continued)

SCHMATIC DESIGNATION	INOVONICS PART NO.	COMPONENT DESCRIPTION (MFGR. / MFGR. P/N)
<u>Integrated Circuits</u>		
IC1-9,13-19	1375	FET-Input Dual Op-Amp; LF353N (open)
IC10,11,12	1313	Dual Op-Amp; RC4558NB (RAYTHEON, T.I.)
IC20-22,30,31	1335	CMOS Quad Analog Switch; CD4066BE (open)
IC23,24,32,33	1301	CMOS 4-bit S/R; CD40194BE (open)
IC25,26,34, 35,37	1322	CMOS Dual-D F/F; CD4013BE (open)
IC27,29	1342	CMOS Quad-AND; CD4081BE (open)
IC28	1338	CMOS Quad-OR; CD4071BE (open)
IC36	1336	CMOS Hex Inverter; CD4069UBE (open)
IC38	1304	Dual High Speed Op-Amp; LM833N (NATIONAL)
IC39,40	1373	Pos. Volt. Reg.; LM317T (open)
IC41,42	1374	Neg. Volt. Reg.; LM337T (open)

Transistors

Q1,2,4,5,7, 8,10,11	1210	NPN, High Beta; 2N5088 (open)
Q3,6,9,12	1205	PNP, Gen. Purp.; 2N3906 (open)
Q13	1224	NPN, Med. Power; MJE340 (open)
Q14	1225	PNP, Med. Power; MJE350 (open)

Resistors

UNLESS NOTED BELOW, fixed resistor values are per schematic notation, in ohms (K = X1000, M = X1Meg). With no tolerance specified, resistor is 5%, 1/4-watt, carbon film; 1% resistors are 1/4-watt, metal film.

Variable resistors with front-panel access are multiturn-type (BECKMAN 89PR series, value per schematic); other "trimpots" are single-turn-type (BECKMAN 91AR series, value per schematic).

Switches

S1-5	1857	DPDT Miniature Slide, Side-Actuated (CW INDUS. / GI-152 PC)
S6	1816	SPDT Slide (CW INDUS. / GF-324)

705 PARTS LIST (continued)

SCHEMATIC DESIGNATION	INOVONICS PART NO.	COMPONENT DESCRIPTION (MFGR. / MFGR. P/N)
--------------------------	-----------------------	----------------------------------------------

Power Transformer

T1	1523	Dual Primary, PC-mounting (TRIAD FP34-340, SIGNAL LP-34-340)
----	------	-----------------------------------------------------------------

Miscellaneous

Y1	1242	Crystal, 1.216MHz (INOVONICS ONLY)
- -	182000	"Dummy Plug" for FMX™ Accessory Socket (INOVONICS ONLY)
- -	181900	8-Position Female Jumper Strip for Mains Voltage Selection.
- -	1737	0.1-inch-spacing "Shunt" (Jumper to set Input Gain, Preemphasis)
- -	2605	Silicone Rubber Insulating Washer for TO-220 Voltage Regulators.
- -	2604	Fiber Shoulder Washer for mounting TO-220 Voltage Regulators.

PARTS LIST - FMX™ OPTION FOR INOVONICS MODEL 705
 (PLUG-IN FOR FM STEREO GENERATOR)

SCHEMATIC DESIGNATION	INOVONICS PART NO.	COMPONENT DESCRIPTION (MFR. / MFR. P/N)
--------------------------	-----------------------	--------------------------------------------

Capacitors

UNLESS NOTED BELOW, capacitor values are per schematic notation in microfarads (uF), except when followed by "P" denoting picofarads (pF).

Values under 470pF are DM-15 (or CM-05) Mica type, 5% tolerance, 600V; manufacturer open.

Values from 470pF through .47uF are polyester ("Mylar") or polycarbonate film type, 5% tolerance, 63V or better; WIMA "MKS" or "FKC" series, Thompson "IRD" series, or equivalent "minibox" format with 0.2-inch lead spacing.

C12	1060	Electrolytic; 4.7uF, 25V (open, radial)
C17,21,22,23,24	1088	Electrolytic, High-Reliability; 2.2uF, 50V (ILLINOIS CAP. / 225RMR050M)

Diodes

CR1-6,8-12	1100	Silicon Signal; 1N4151 (open)
CR7	1104	Silicon Zener, 6.2V, 5%; 1N4735A (open)

Integrated Circuits

IC1-3,5,6, 8-11,13	1375	FET-Input Dual Op-Amp; LF353N (open)
IC4,7	1313	Dual Op-Amp; RC4558NB (RAYTHEON, T.I.)
IC12,14,15	1335	CMOS Quad Analog Switch; CD4066BE (open)
IC16,17	1301	CMOS 4-Bit S/R; CD40194BE (open)
IC18,19,22,23	1322	CMOS Dual-D F/F; CD4013BE (open)
IC20	1342	CMOS Quad-AND; CD4081BE (open)
IC21	1338	CMOS Quad-OR; CD4071BE (open)
IC24	1350	CMOS Programmable Divider; CD4059AE (open)

Transistors

Q1,2	1234	FET, Matched pair (INOVONICS ONLY)
Q3,4	1210	NPN, High Beta; 2N5088 (open)

FMX™ OPTION PARTS LIST (continued)

SCHMATIC DESIGNATION	INOVONICS PART NO.	COMPONENT DESCRIPTION (MFGR. / MFGR. P/N)
-------------------------	-----------------------	----------------------------------------------

Resistors

UNLESS NOTED BELOW, fixed resistor values are per schematic notation, in ohms (K = X1000, M = X1Meg). With no tolerance specified, resistor is 5%, 1/4-watt, carbon film; 1% resistors are 1/4-watt, metal film.

Variable resistors with front-panel access are multiturn-type (BECKMAN 89PR series, value per schematic); other "trimpots" are single-turn-type (BECKMAN 91AR series, value per schematic).

Miscellaneous

- -	182100	Interconnect ("Pigtail") Cable Assy, FMX™ Plug-In to Main Board (INOVONICS ONLY)
-----	--------	----------------------------------------------------------------------------------------

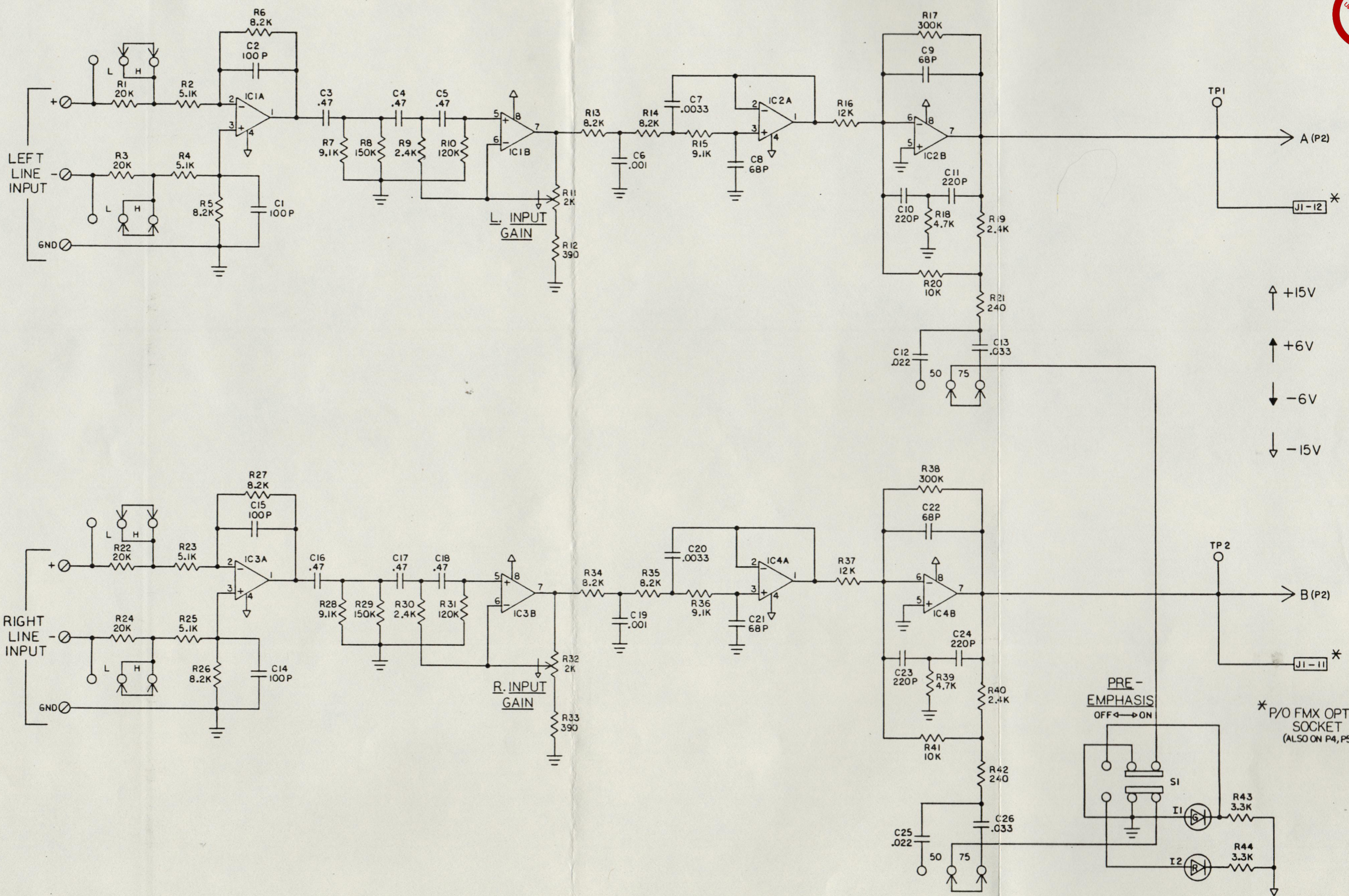

37

If You Didn't Get This From My Site,
Then It Was Stolen From...
www.SteamPoweredRadio.Com

705	DRAWN	JIM	7-30-87	INOVONICS
	CHECKED			
TITLE				SCHEMATIC, FM STEREO GEN.
MATERIAL / FINISH				
TOLERANCES	PAGE			ISSUE
2PL ± 01 3PL ± 008 ANGLES 2:1	1 of 5			181500 A

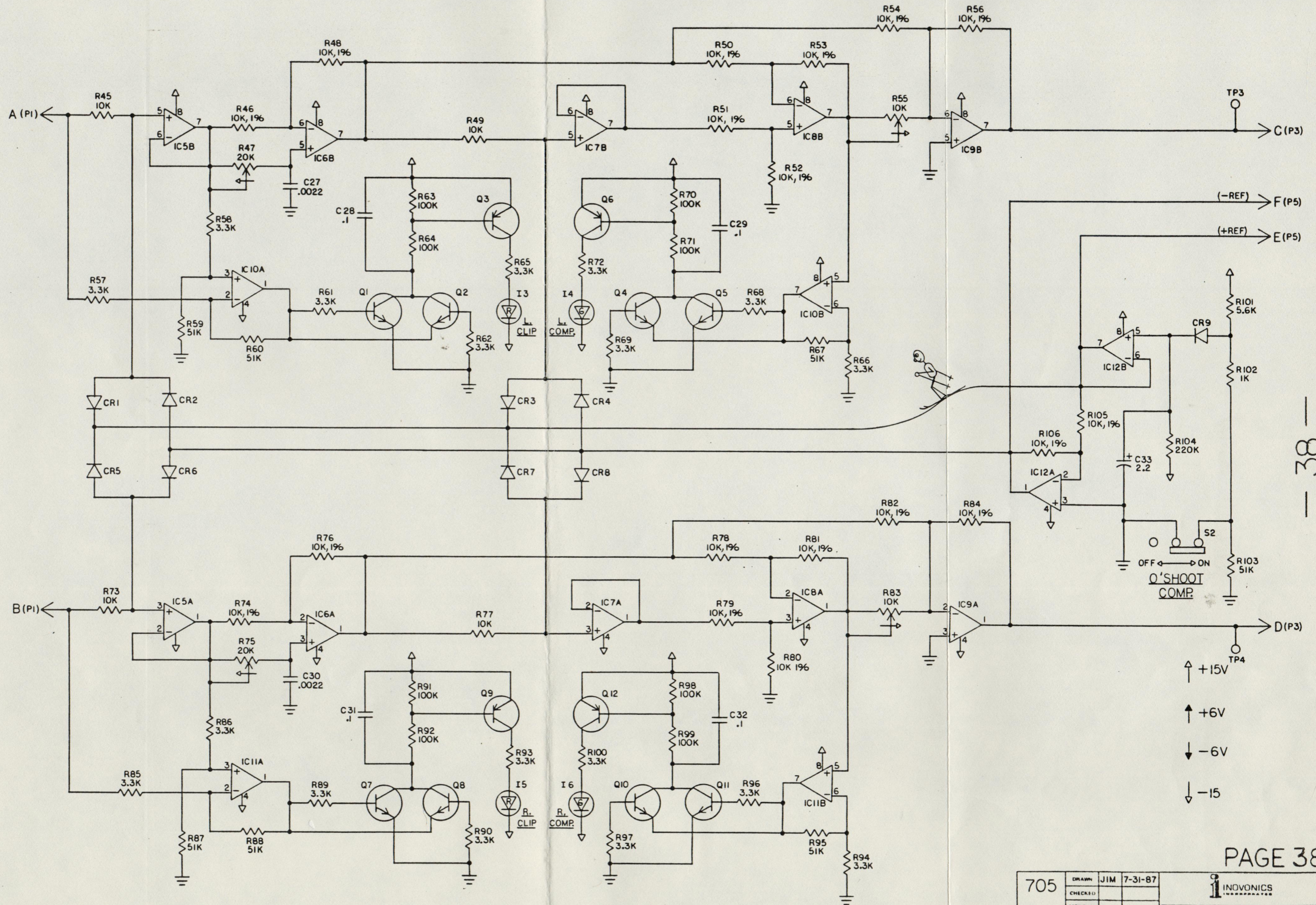

If You Didn't Get This From My Site,
Then It Was Stolen From...
www.SteamPoweredRadio.Com

705	DRAWN	JIM	7-31-87	INOVONICS
	CHECKED			
TOLERANCES		MATERIAL / FINISH		TITLE
3PL ± 01		—		SCHEMATIC,
3PL ± 008		—		FM STEREO GEN.
ANGLE ± 1°		—		PAGE
		2 of 5		DRWG NO
		181500		REUSE
				A

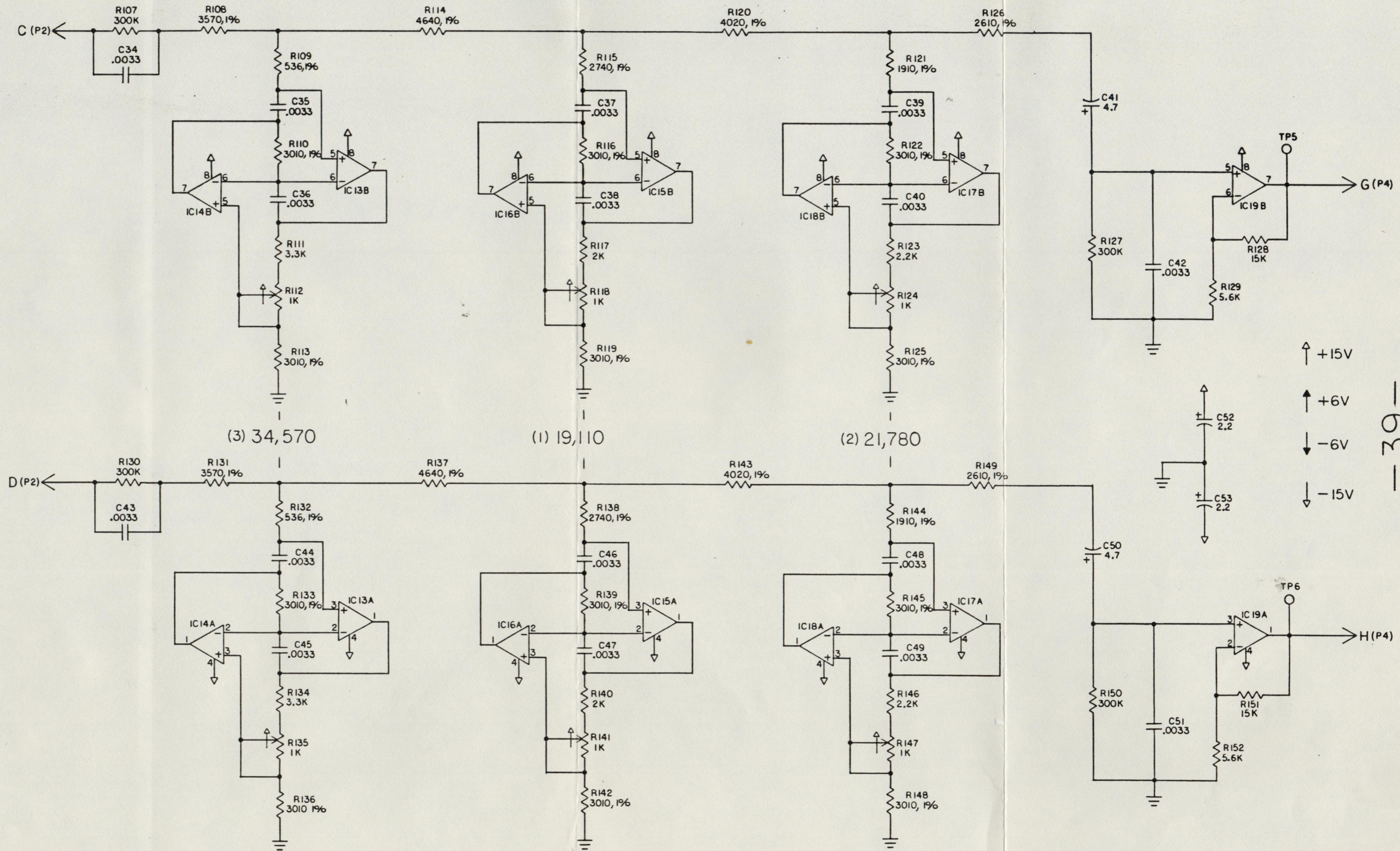

If You Didn't Get This From My Site,
Then It Was Stolen From...
www.SteamPoweredRadio.Com

705	DRAWN: JIM	8-4-87	
	CHECKED:		
	APPROVED:		TITLE: SCHEMATIC, FM STEREO GEN.
TOLERANCES:	MATERIAL / FINISH:		PAGE: 3 of 5
3PL: 01			DRWG NO: 181500
3PL: 006			ISSUE: A
ANGLES: 1°			

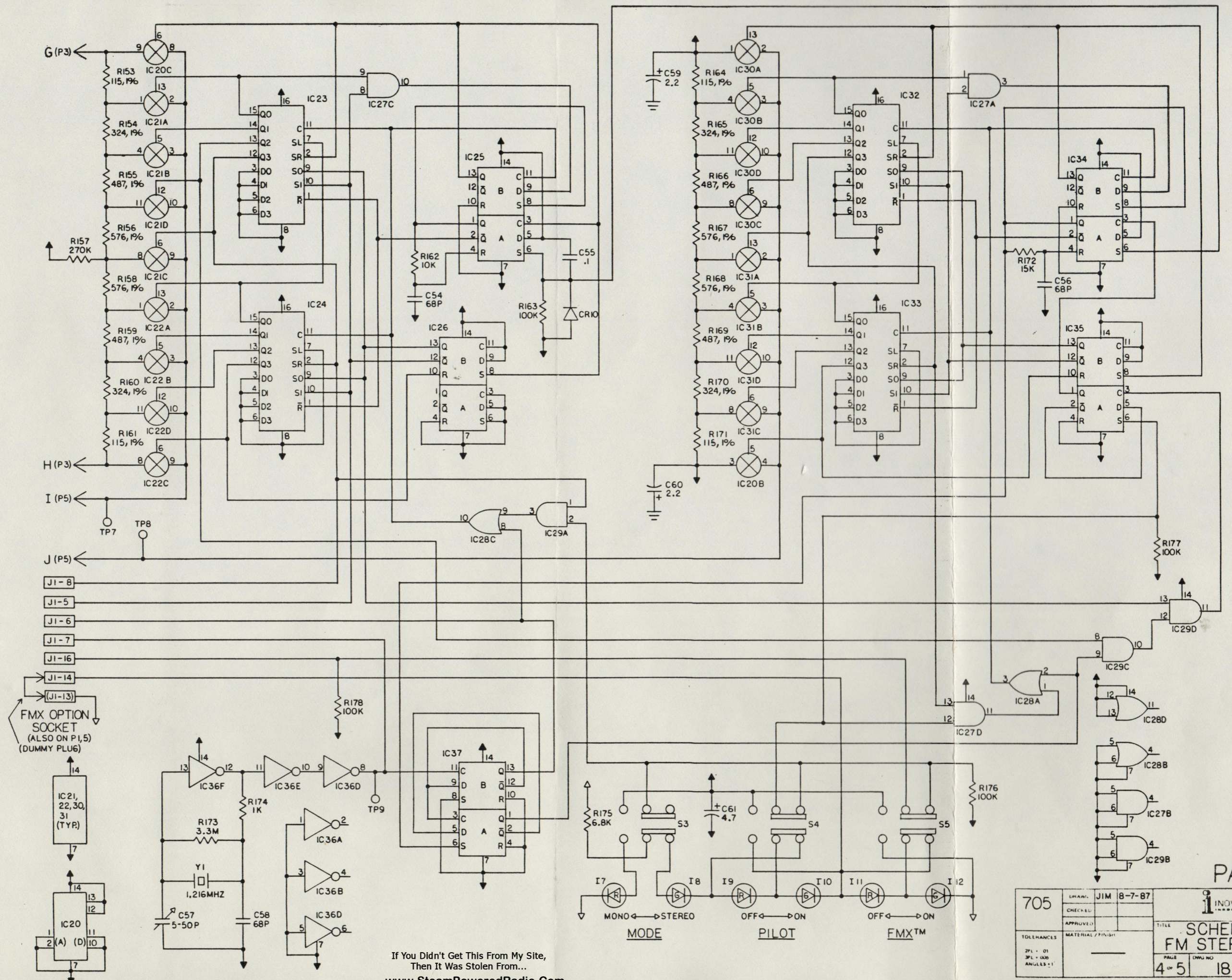

↑ +15V
 ↑ +6V
 ↓ -6V
 ↓ -15V

If You Didn't Get This From My Site,
 Then It Was Stolen From...
www.SteamPoweredRadio.Com

705	DRAWN: JIM 8-7-87	INOVOONICS
	CHECKED:	
APPROVED:	TITLE: SCHEMATIC, FM STEREO GEN.	ISSUE: A
TOLENCES: 2PL - 01 3PL - 006 ANGLES: 1	MATERIAL / FINISH:	PAGE: 4 of 5
		DRAW NO: 181500

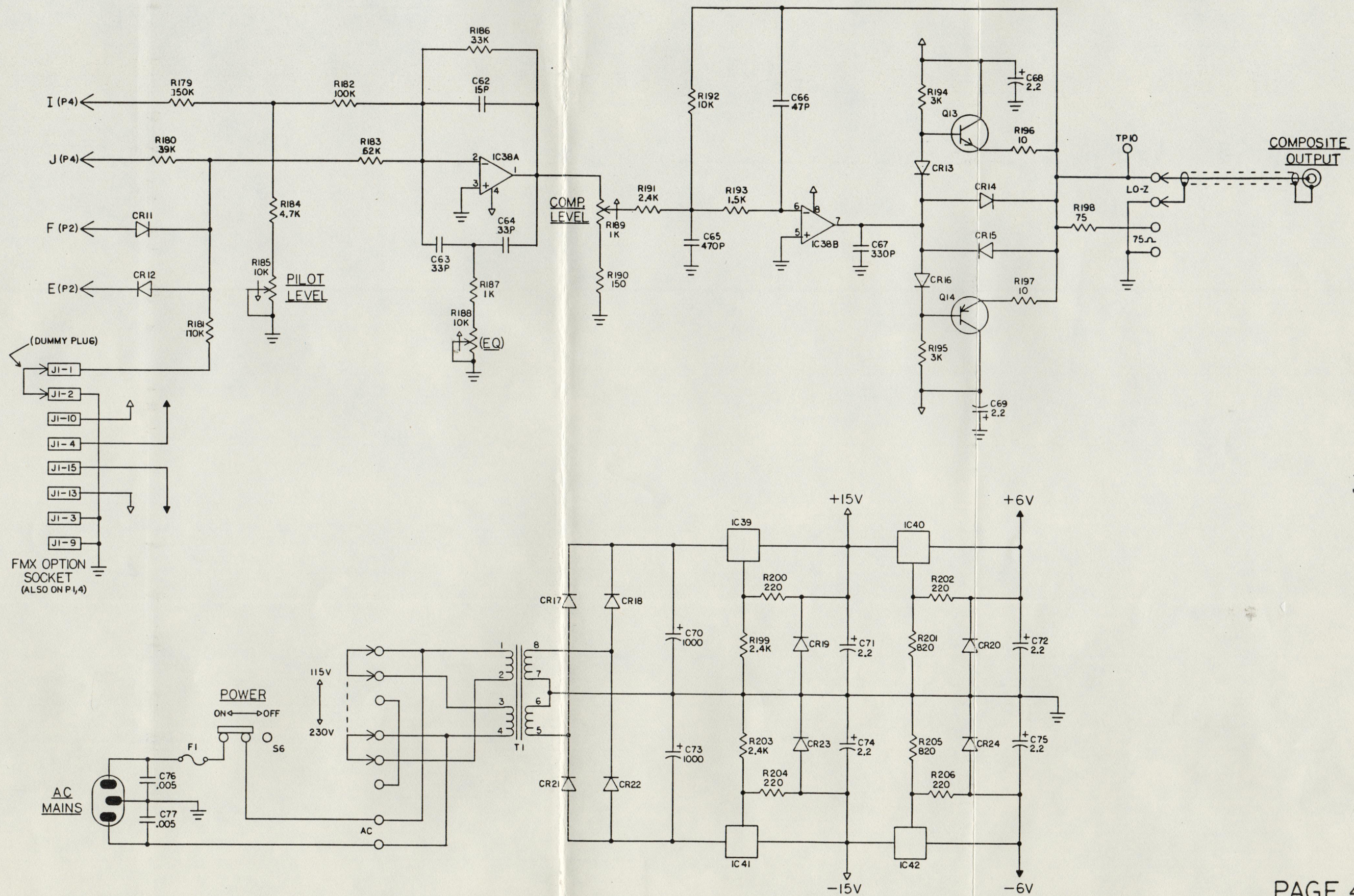

If You Didn't Get This From My Site,
Then It Was Stolen From...
www.SteamPoweredRadio.Com

705	DRAWN	JIM	8-7-87	INOVONICS
	CHECKED			
TOLERANCES		MATERIAL / FINISH		TITLE SCHEMATIC, FM STEREO GEN.
2PL ± 01	3PL ± 008	ANGLES: 1°		
			DWG NO.	ISSUE
			181500	A

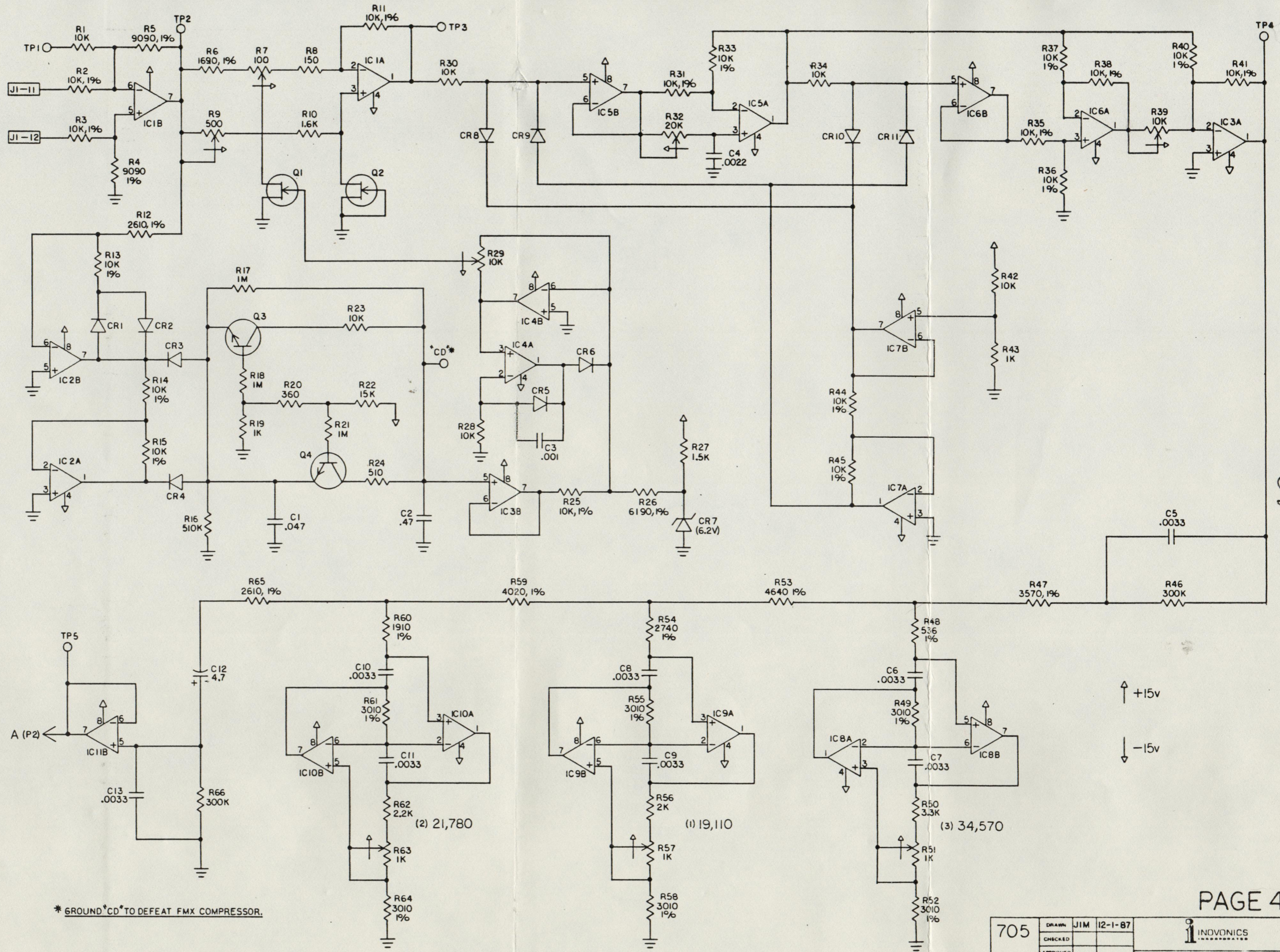

* GROUND CD* TO DEFEAT FMX COMPRESSOR.

If You Didn't Get This From My Site,
Then It Was Stolen From...
www.SteamPoweredRadio.Com

- 42 -

PAGE 42

705	DRAWN	JIM	12-1-87	
	CHECKED			
TOLERANCES		MATERIAL / FINISH		TITLE
2PL - 01 3PL - 008 ANGLES 1°				SCHEMATIC, FMX™ OPTION
PAGE		DRAWING NO.		ISSUE
1 of 2		181600		A

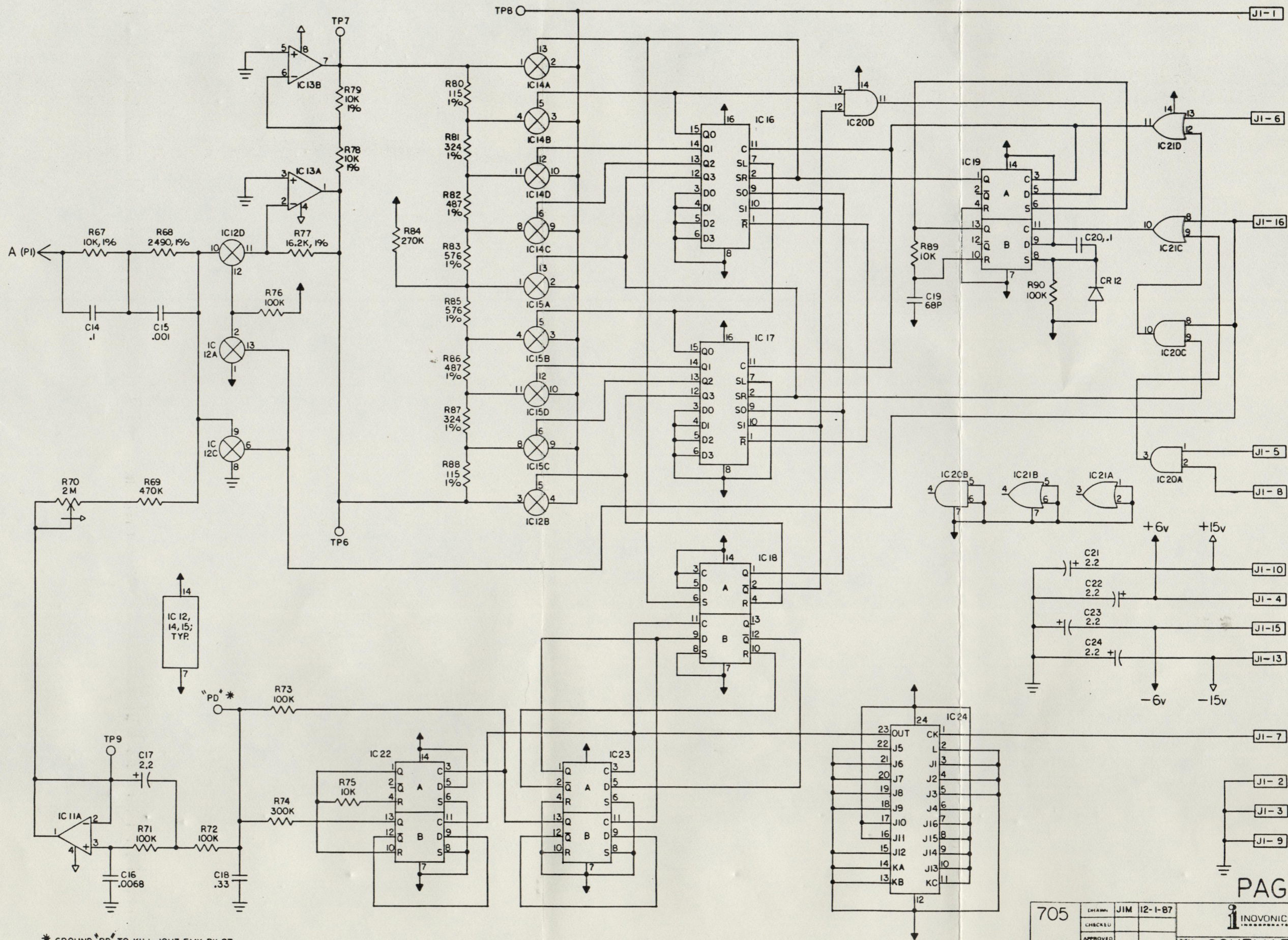

* GROUND PD TO KILL 10HZ FMX PILOT.

If You Didn't Get This From My Site,
Then It Was Stolen From...
www.SteamPoweredRadio.Com

43

705	DRAWN	JIM	12-1-87		TITLE	SCHEMATIC, FMX™ OPTION		
	CHECKED				MATERIAL / FINISH			
	APPROVED							
2PL - 01 3PL - 008 ANGLES: 1	PAGE		2 OF 2	DWG NO		181600	ISSUE	A

INOVONICS WARRANTY

Inovonics, Inc. products are warranted to be free from defects in material and workmanship. Any discrepancies noted within 90 days of the date of purchase will be repaired free of charge. Additionally, parts for repairs required between 90 days and one year from the date of purchase will be supplied free of charge, with installation billed at normal rates. It will be the responsibility of the purchaser to return equipment for warranty service to the dealer from whom it was originally purchased unless prior arrangement is made with the dealer to inspect or repair at the user's location.

This warranty is subject to the following conditions:

1. Warranty card supplied with the equipment must be completed and returned to the factory within 10 days of purchase.
2. Warranty is void if unauthorized attempts at repair or modification have been made, or if serial identification has been defaced, removed, or altered.
3. Warranty does not apply to damage caused by misuse, abuse, or accident.
4. Warranty valid only to original purchaser.



