



INSTRUCTION MANUAL
MODEL 380
MAGNETIC RECORDING ELECTRONICS

If You Didn't Get This From My Site,
Then It Was Stolen From...
www.SteamPoweredRadio.Com



INSTRUCTION MANUAL
MODEL 380
MAGNETIC RECORDING ELECTRONICS

May, 1981

If You Didn't Get This From My Site,
Then It Was Stolen From...
www.SteamPoweredRadio.Com



503-Vandell Way, Campbell, CA 95008
(408) 374-8300

TABLE OF CONTENTS

I.	GENERAL INFORMATION	2
II.	SPECIFICATIONS	3
	Frequency Response - Signal-to-Noise Ratio - Recorded Distortion - Equalization - Erasure - Erase Frequency - Bias Frequency - "Pickup" Record Delay - Head Impedance Range - Line Input - Line Output - Metering - Power Requirements - Size and Weight	
III.	INSTALLATION	6
	Unpacking and Inspection - Mounting - Connection - Line In/Out Considerations - RECORD Logic Option - Erase Head Tuning - NAB/IEC L.F. Record Selection - Reproduce Head Matching	
IV.	OPERATION AND FUNCTIONAL DESCRIPTION	10
	Panel Controls	
V.	CALIBRATION	12
	Equipment Required - Reproduce Calibration - SYNC Reproduce Calibration - Input Level and Meter Calibration - Erase/Bias Adjustment - Record Calibration - Phase Compensation and Linearity Adjustments - "Pickup" Record Timing	
VI.	CIRCUIT DESCRIPTIONS	18
	Reproduce Board - Record Board - Logic Board - Power Supply	
VII.	APPENDIX	24
	Parts Lists - Schematics - Warranty	

I. GENERAL INFORMATION

The Model 380 represents Inovonics' fourth generation of self-contained Magnetic Recording Electronics for professional audio recording applications. Features which were optionally available in earlier versions have now been included as standard; and with its additional operational and performance updatings, the 380 is suitable either for new OEM installations or for substantially improving the performance of existing magnetic tape and film recording equipment.

Features of the 380 include:

Equalization, level and bias adjustments for routine, two-speed operation, and an "optimized" operating mode with a third, separate set of adjustments for a different tape stock, operating level, track format, equalization, etc.

Accommodates a wide variety of original-equipment and replacement high or low impedance heads, and interfaces with nearly all film and tape transports.

"Pickup" (insert) Record Capability with adjustable delay, and "Sync" Reproduce with automatic monitor transfer.

Increased erase, bias and signal headroom for high coercivity tapes.

Defeatable "Auto Mute" circuit to attenuate playback during high speed search.

Provision for remote selection of monitor function and equalization.

Adjustable circuitry to reduce the effects of tape compression and phase distortions.

Switchable "VU" or 10ms, quasi-peak program metering.

The 380 requires only the proper interconnect cable to interface with nearly any combination of transport and heads. Two or more units may be interconnected for stereo or multi-track operation. If no specification is made at time of order, the 380 is supplied with cabling for Ampex 350-series, full-track machines.

II. SPECIFICATIONS

Performance of any magnetic recording system is limited in great part by the electrical and magnetic efficiency of the heads and the formulation of the magnetic oxide. Recording electronics actually constitute the "easy part" of the system. As the 380 is intended for use in critical, high-performance recording applications, the subject specifications were derived using heads and tape of known high quality.

The one-quarter-inch, two-track format used to obtain operating specifications indicates expected performance of two- or multi-track systems with 70-80 mil track widths. Heads were manufactured by Saki Magnetics, Culver City, CA, and are of all-ferrite construction. Part numbers and pertinent information are listed below.

HEAD	kHz Inductance	DC Resistance	Gap Length
REPRODUCE			
Saki #P-60102	500mH	375-Ohms	140u"
RECORD			
Saki #W-60102	5mH	40-Ohms	220u"
ERASE			
Saki #E-60102	0.5mH	3-Ohms	N/A

Tape employed in the tests was Ampex 456; Operating Level, 250nW/m; NAB equalization at 7-1/2 and 15ips, AES equalization at 30ips.

Frequency Response (in Hz):

	OVERALL	SYNC REPRODUCE
30ips	±1dB, 45-25k	±1dB, 60-20k
15ips	±1dB, 25-20k	±1dB, 30-20k
7-1/2ips	±1dB, 20-18k	±1dB, 20-16k

Signal-to-Noise Ratio (in dB, referred to a "peak" record level 6dB above 250nW/m; 20Hz - 20kHz):

	OVERALL		STANDBY	
	u'wtd.	wtd.	u'wtd.	wtd.
30ips	65	74	79	86

	OVERALL		STANDBY	
	u'wtd.	wtd.	u'wtd.	wtd.
15ips	63	72	75	84
7-1/2ips	64	72	75	84

Recorded Distortion (at 15-mil wavelength bias peak; 15ips):

	HIGH SPEED (uncorrected)	OPTIMIZED MODE ("linearized")
Operating Level	.40%	.35%
3dB above Op Level	.50%	.40%
6dB above Op Level	.95%	.70%
9dB above Op Level	2.50%	.85%

Equalization:

Accommodates NAB, IEC, AES or mixed characteristics for 3-3/4 through 30ips.

Erase:

>75dB erasure of 500Hz signal recorded 12dB above Op Level.

Erase Frequency:

125kHz

Bias Frequency:

250kHz

"Pickup" (Insert) Record Delay:

Bias ramp-up and -down may be offset from that of erase by 12 to 120ms in HIGH SPEED and OPTIMIZED MODE. Delay doubles in LOW SPEED.

Head Impedance Range:

Erase: 0.2 to 2.0mH

Record: 3 to 10mH

Reproduce: 3mH to 1H

Line Input:

"Electronically-balanced," bridging; accepts nominal line levels between -10 and +10dBm in CALIB position of INPUT GAIN control. Control affords additional ± 12 dB gain range.

Line Output:

Balanced, transformer-isolated, with provision for balanced, transformerless operation, if desired. May be adjusted for nominal line levels between +4 and +10dBm. Clipping level, +28dBm into 600-ohm load; +30dBmV into bridging inputs.

Metering:

Front panel meter may be switched between "VU" and quasi-peak response with 10ms (UK/EBU) integration.

Power Requirement:

105 - 130VAC (230V available), 50/60Hz; 0.3A (plus transport).

Size and Shipping Weight:

3-1/2" X 19" X 7"; 13 lbs.

III. INSTALLATION

Unpacking and Inspection

Upon receipt, promptly inspect the equipment for shipping damage. Should any be observed, notify the carrier; if not, proceed as outlined below. It is suggested that the original shipping carton and materials be retained for future reshipment if it should become necessary. In the event of return for repair under terms of the Warranty, damage sustained as a result of improper repacking may invalidate the Warranty.

It is essential that the Warranty Registration card found at the front of this manual be returned. This assures coverage of the equipment under terms of the Warranty, and the user will automatically receive specific servicing or modification information when issued.

Mounting

The 380 is packaged to mount in a standard 19-inch equipment rack or recorder overbridge with EIA mounting provision. Each channel requires 3-1/2 inches of vertical rack space and about 8 inches of cabinet depth to accommodate back-panel connectors.

Connection

The signal, head and transport inter-cabling is pin-compatible with the equipment specified for use with the 380 at time of order. If no specification is made, Ampex 350-series interconnect is assumed and such cabling is included.

When two or more units are used in stereo or multi-track installations, a "daisy-chain" style of interconnect cable is supplied which provides erase/bias oscillator "slaving" and common transport logic interface. Normally, input power will be first fed to the bottom-most unit and the cable "daisy-chained" up to the second and subsequent channels. In such an installation, the lower unit serves as erase/bias oscillator "master," feeding all channels in the system. All electronics are identical, however; it is the cable that dictates the master/slave relationship.

Line In/Out Considerations

As delivered, the 380 is calibrated to operate at a +4dBm line level corresponding to "zero-VU." Operation at other line levels can be accommodated; see section V, pages 12 through 13 for level setting procedure, and page 14 for adjustment of panel meter calibration.

Input impedance of the 380 is 200k-Ohms, balanced, or 100k-ohms, unbalanced. Should the equipment which feeds the 380 require a terminating load, a resistor may be connected in parallel with the 380 input. In unbalanced, single-ended installations, either side of the input may be tied to ground, although pin 3 of the input connector is generally considered "hot."

The low source impedance of the 380 line output results in only about a 0.5dB shift in level from an unloaded to a 600-Ohm-loaded condition. Although a 600-Ohm termination is not necessary, the 380 should nevertheless be connected to its intended load prior to final calibration.

When used in the optional "transformerless" output configuration, it is important that the 380 feed true balanced, differential inputs. This configuration does not tolerate having one side grounded as does the normal, transformer-isolated, balanced output.

RECORD Logic Option

Two sets of terminals on the Logic Board (A/N 158600) are associated with a user-accessible change to transport RECORD logic. These terminals are located near the left-rear of the board and are labeled A and B.

With Ampex and similar transports, the factory-installed straps on both the A and B terminals enable basic, single channel operation. With the transport in PLAY and the 380 in READY, the unit will enter the RECORD mode when the RECORD button is pressed. When two or more units are interconnected for stereo or multi-track use, and one channel is similarly in RECORD, a companion channel will enter the RECORD mode when it is placed in READY. By removing the B strap, once one channel is in RECORD and another made READY, the RECORD button must be pressed a second time to put that channel into the RECORD mode. With the B strap removed, however, the RECORD indicator on older Ampex-style transport remote control units will not light.

Scully transports, with logic somewhat inverted from that of Ampex decks, require that the A strap be removed.

Erase Head Tuning

Four sets of terminals on the Record Board (A/N 158200) select the tuning capacitance to bring the erase head to resonance at the erase frequency of 125kHz. These terminals are located at the left-rear of the board and are labeled A, B, C and D.

If the inductance of the erase head is known, the terminals may be strapped according to the following table:

HEAD INDUC- TANCE - mH	A	B	C	D
0.2	X	X	X	X
0.3	X	X		
0.5		X	X	
0.75	X			X
1.0		X		X
1.25	X			
1.5		X		
1.75			X	
2.0			X	

The panel meter, when switched to the ERASE position, monitors voltage across the erase head. This can be used as a relative indicator of erase drive to help tune the head to resonance. If inductance of the erase head is unknown, the 380 can be put into the RECORD mode and various combinations of the A, B, C and D jumpers tried for maximum meter indication. Once optimum tuning is established, the jumpers may be permanently soldered in place.

One note of warning concerning the foregoing:

The 380 erase amplifier has sufficient drive for full erasure of highest coercivity tapes with heads of normal efficiency. Some of the common, "universal replacement" heads can have their modest magnetic structures driven into saturation by the 380. This can overheat and possibly destroy the head, as well as cause noise in the recording process. There is, nevertheless, a self-protection factor which, when taken into account, guarantees that the head will not be overdriven and damaged.

As a head core starts to go into saturation, inductance changes abruptly. In order to overdrive the head and saturate the core, a tuning capacitance would be required which is different from the value used to resonate the head at low drive levels. Thus if a tuning capacitance is selected for low-level resonance, drive will self-limit when the head inductance starts to change.

If confronted with a question in this area, it is best to measure accurately head inductance with a bridge or consult the manufacturer for the information, and use the table on page 8, rather than experimentally tune for maximum drive.

NAB/IEC L.F. Record Selection

Three sets of terminals on the Record Board (A/N 158200) enable selection of either a flat (IEC) or a boosted (NAB) low frequency recording characteristic for each of the three equalization positions. These terminals are located close to the center of the board and are labeled L, H and O, corresponding to LOW SPEED, HIGH SPEED and OPTIMIZED MODE. With jumpers in place (as shipped), the NAB low frequency recording characteristic is engaged for all three equalizations. When a jumper is removed, a flat (IEC) characteristic is imparted to the associated equalization position.

Reproduce Head Matching

The 380 accommodates reproduce heads of either a nominal high impedance, typically 200mH to 1H, or low impedance with values between 3 and 10mH. The reproduce amplifier input characteristic is selected by a set of four terminals near the right-rear of the Reproduce Board (A/N 157900). These are labeled A, B, C and D.

Without jumpers the 380 accepts high output, high impedance heads as encountered in Ampex 350-series or Scully 280-series full-track machines. Some heads in the Hi-Z category may require additional amplifier gain. These heads may be two-track, or have even a narrower track format, or merely have fewer windings. Need for more gain will quickly be determined during the Reproduce Alignment Procedure (page 12) when it is found that the REPRO LEVEL calibrate pots cannot be turned up quite far enough. The additional gain required by heads of lower output, but still of nominal high impedance, is obtained by installing a jumper between terminals A and B.

Low impedance reproduce heads require a jumper between terminals A, B and C. Again, should it be found that some additional gain is required, the jumper should be extended to include A, B, C and D.

IV. OPERATION AND FUNCTIONAL DESCRIPTION

Panel Controls

The INPUT GAIN and REPRO GAIN controls have a detented CALIB position at full CCW rotation. They are normally left in CALIB except for temporary correction for an improperly recorded tape or an abnormal line level. Both these controls have a $\pm 12\text{dB}$ range referred to CALIB.

MONITOR buttons select the signal source to be routed to the Line Output and front-panel level meter. Manual selection may be made of the INPUT signal; REPRO, or normal playback from the reproduce head; or SYNC playback from the record head (used as a reproduce head) when it is necessary to monitor one track of a multi-track recording in synchronism with a different track being recorded. In SYNC reproduce, MONITOR automatically transfers to INPUT when the channel enters RECORD.

When a MONITOR button is slightly depressed so that all three buttons are "out," the monitor selection is transferred to a rear-panel connector for remote selection. The schematic below shows what contact arrangement must be provided at the remote monitor switching point. The front-panel MONITOR buttons override remote commands.

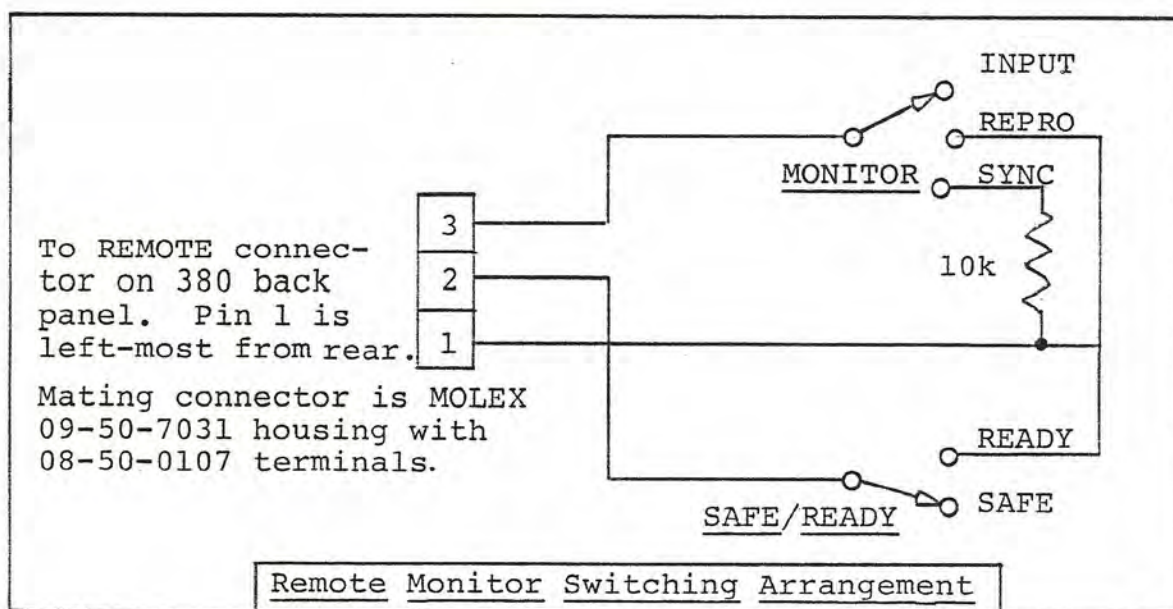

AUTO MUTE is a feature which attenuates playback, either REPRO or SYNC, by about 20dB when the button is "in" and the transport is in other than the PLAY mode. This acts as an electronic "head lifter" in fast-forward or rewind. When the button is "out," full gain is restored for editing, etc.

The LOW SPEED, HIGH SPEED and OPTIMIZED MODE buttons are associated with the three recording and playback equalization positions. All trim controls designated LO, HI or OPT are enabled when the appropriate button is depressed. Controls labeled LO/HI are enabled in both LOW SPEED and HIGH SPEED. In addition, record "pickup" timing is doubled in LOW SPEED over the value set in HIGH SPEED and OPTIMIZED MODE. When all three buttons are "out," equalization switching is transferred via the transport interconnection to a transport SPEED switch, if provided; the switching arrangement is diagrammed below. In any case, front-panel buttons override remote switching commands. In stereo or multi-track installations without transport equalization switching, all channels but one may be left with their buttons "out," and will be slaved to the one channel used to select equalization.

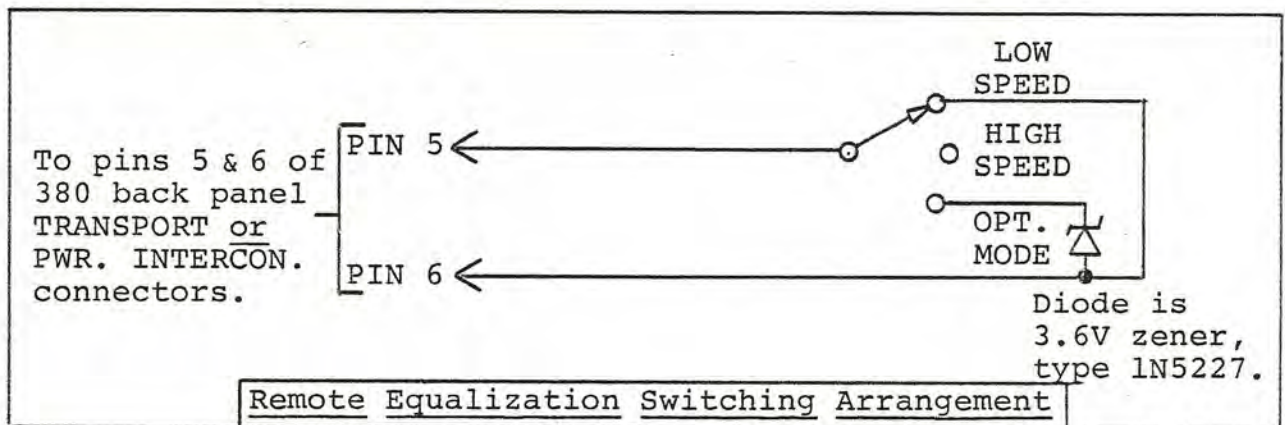

With the READY button "in," the 380 panel meter will flash "red" at about a 1Hz rate whenever the tape transport is in PLAY, and the unit will enter the RECORD mode when the RECORD button is pressed. With the READY button "out," the 380 is "safe," and will not enter RECORD under any circumstance.

The POWER switch controls primary AC power to the 380, and to the tape transport if powered by the electronics.

The 'PHONES jack monitors the Line Output. This jack is ground-referenced and isolated from the balanced output. It may be used for testing, but the level at this point is about 6dB below the nominal line level.

V. CALIBRATION

Equipment Required

Proper alignment of the 380 will require the following test gear:

Head Demagnetizer
Appropriate Reproduce Alignment Tapes
Audio Oscillator
AC Electronic Voltmeter

Reproduce Calibration

1. Establish the nominal impedance of the reproduce head and jumper the appropriate terminals per instructions on page 9.
2. Depress the INPUT MONITOR button and clean and demagnetize all heads, moving very slowly while the demagnetizer is near the heads and withdrawing it about a yard from the head assembly before turning it off.
3. Depress the REPRO MONITOR button and thread an alignment tape appropriate for the equalization to which the 380 is switched.
4. With the front panel REPRO GAIN control in the full CCW, CALIB position, play the Operating Level tone on the alignment tape and adjust the appropriate REPRO LEVEL trim pot for the nominal line level as measured by the AC voltmeter connected to the 380 Line Output. If the adjustment is not within the range of this pot, refer to page 9 for restrapping instructions.
5. While reproducing the highest frequency on the test tape, adjust the reproduce head azimuth for maximum output.
6. With high impedance reproduce heads, if the resonance of the head is near the top of the passband (as is usually the case for best signal-to-noise performance), a peak in response will be noted at the highest frequencies. The REPRO HEAD DAMPING pot adjusts the "Q" of this primary head resonance. To determine the proper setting, turn the appropriate GAP LOSS EQUAL pot fully CCW and set playback for flat response at 4-6kHz with respect to the reference tone using the HIGH FREQ EQUAL pot. Note response at the highest frequencies and adjust the REPRO HEAD DAMPING pot for flattest high-end response. This procedure is best

done at the highest speed that will be used, and is relevant to high impedance heads only. When low-Z heads are used, the REPRO HEAD DAMPING pot should be left fully CW.

7. With the HIGH FREQ EQUAL and GAP LOSS EQUAL pots, playback response can be set for flattest response from reference frequency to highest frequency. The GAP LOSS EQUAL pot is used to trim the very highest frequencies, but it interacts with the HIGH FREQ EQUAL adjustment to some extent at the mid-highs.
8. If the alignment tape has the same track width as the reproduce head track, set the appropriate LOW FREQ EQUAL pot for smoothest response from reference frequency to the lowest frequency. If this is not the case, as with full-track test tapes and two-track machines, wait until step 5 of Record Calibration, page 15.
9. Repeat steps 3, 4, 7 and (if applicable) 8 for the other speeds or formats, including allowances for a different Operating Level in the OPTIMIZED MODE, if desired. It is advisable to make the final repro head azimuth adjustment at the lowest speed to be used.

SYNC Reproduce Calibration

Depending on the mechanical and magnetic parameters of the recording head, SYNC reproduce performance can range from the equal of normal reproduce to substantially worse. Only in the OPTIMIZED MODE are separate HIGH FREQ and GAP LOSS equalization adjustments provided; otherwise, HIGH and LOW SPEED equalization is the same for SYNC as for normal REPRODUCE, as is the low frequency characteristic for all three positions.

1. Depress the SYNC MONITOR button and thread an alignment tape appropriate to the equalization to which the 380 is switched.
2. With the front-panel REPRO GAIN control in CALIB, play the Operating Level tone on the alignment tape and adjust the SYNC MATCH pot on the Record Board for the same Line Output level as in step 4 of the Reproduce Calibration procedure. Once this has been done, SYNC playback level should track the normal REPRODUCE level for all three equalizations.
3. While reproducing the highest frequency on the test tape, adjust record head azimuth for maximum output. As with normal REPRODUCE, the most accurate adjustment of azimuth will be at the lowest speed used.

4. Note deviation from flat response at LOW and HIGH SPEED. Adjust for best SYNC reproduce response in the OPTIMIZED MODE as in step 7 of Reproduce Calibration.

Input Level and Meter Calibration

1. Feed a 1kHz signal from the audio oscillator to the 380 Line Input at nominal line level.
2. With the front-panel INPUT GAIN control in CALIB., depress the INPUT MONITOR button and adjust the INPUT GAIN trim pot on the Record Board for a nominal line level output as measured by the AC voltmeter connected to the 380 Line Output.
3. At this point, switch the METERING selector on the Logic Board to "VU" and adjust the "VU" METER CAL pot for a "0VU" indication.

NOTE: In order for a peak-responding meter to give meaningful, or, for that matter, "on-scale" indications from program material, it must be adjusted for a "program reference" deflection corresponding to a sine wave signal equal to a program peak level. This is unlike a "VU" meter which is adjusted for a "zero" with a tone representing the average program level. Another way of putting this is that a steady-state, line level signal would produce a PPM indication several dB below the corresponding "VU" reading.

There are several schools of thought with respect to the "proper" average-to-peak differential for PPM calibration based on varying types of program material and the meter integration characteristic. For normal speech and music and the UK/EBU 10ms response, these figures usually fall between 6 and 10dB. Most recent studies suggest that 8dB is optimum; thus the calibration procedure described here will be based on an 8dB differential. Should the user have strong convictions to the contrary, he should by all means feel free to substitute another number.

4. Switch the METERING selector to "PPM" and adjust the "PPM" METER CAL pot for a reading of "-8VU," or other average/peak offset factor as desired.
5. Reset the METERING selector to "VU." Use this position for calibration and response measurement, etc. The "PPM" position is for use only in monitoring speech and music on a "Peak Program" basis.

Erase/Bias Adjustment

Erase head tuning is covered under Section III, INSTALLATION, page 8.

Historically, bias is adjusted for maximum recording sensitivity at a 15-mil-wavelength (1kHz at 15ips). Present-day tapes and film stock with higher coercivity oxides may require a biasing procedure slightly different from this method. Follow the manufacturers' recommendation for best performance; the 15-mil-wavelength "peak" method is the one used in the following Record Calibration procedure.

Record Calibration

1. Program the record amplifier for the proper combination of low frequency recording characteristics per NAB/IEC L.F. Record Selection, page 9.
2. Turn the OPT PHASE COMP and OPT LIN pots fully CCW. Thread the machine with fresh tape of the type to be used in routine LOW and HIGH SPEED operation.
3. Select HIGH SPEED and INPUT MONITOR. Apply a 1kHz signal to the 380 input which will yield a "0 VU" panel meter indication.
4. Put the tape transport and the 380 into RECORD at the appropriate speed and monitor REPRO. Adjust the LO/HI BIAS ADJ pot for a "peak" in the recorded signal, and the LO/HI FLUX ADJ pot for a REPRO MONITOR meter indication of "0 VU."
5. Sweep the oscillator frequency downward from the 1kHz reference. If the reproduce amplifier low frequency equalization was not adjusted in Reproduce Calibration step 8, page 13, the LOW FREQ EQUAL - HI pot may be adjusted for flattest response at this time.
6. Sweep the oscillator frequency upward and adjust the RECORD H.F. EQUAL - HI pot for flattest overall response.
7. Repeat steps 5 and 6 for LOW SPEED, adjusting the appropriate LO trim pots for flattest overall response. In the case of 7-1/2 or 3-3/4ips operation, the front-panel INPUT GAIN control should be turned down by 10 or 12dB, and the REPRO GAIN control turned up by the same amount to make response adjustments at a reduced flux level. This will guard against tape saturation at high frequencies.

8. Rethread the machine with "premium" tape of the type for use in the OPTIMIZED MODE.
9. With a 1kHz, line level signal feeding the 380, check that the meter still reads "0 VU" in INPUT MONITOR.
10. Put the transport and the 380 into RECORD in the OPTIMIZED MODE at the appropriate transport speed. Monitor REPRO and adjust the OPT BIAS ADJ pot for a "peak" in the recorded signal, and the OPT FLUX ADJ pot for a REPRO MONITOR meter indication of "0 VU."
11. Repeat steps 5 and 6 for the OPTIMIZED MODE, adjusting the appropriate OPT pots as required to gain flattest overall response.

Phase Compensation and Linearity Adjustments

There are two additional 380 record amplifier adjustments which are enabled only in the OPTIMIZED MODE. The circuitry associated with these adjustments compensates for certain distortions which are generated as a normal part of the magnetic recording process.

In the usual magnetic recording system, long-wavelength signals are recorded on the oxide at a point close to the center of the recording head gap. Short wavelengths, on the other hand, are centered about the gap's trailing edge. This creates a phase displacement between low and high frequency components of a complex program waveform. Although studies have shown that this rather small amount of phase distortion is not audible in speech and music, by the time a signal has gone through several generations of re-recording, the cumulative effects of the phenomenon may be perceived as a "smear," or loss of "definition" in program quality.

The 380 record amplifier contains a variable phase-shift circuit which may be adjusted to introduce a similar, but complementary phase distortion in the input signal prior to recording. The net effect is a signal on tape with full phase integrity. A 1kHz square wave signal is fed to the 380 at a level 6dB or so below "0 VU." The 380 is put into RECORD in the OPTIMIZED MODE, and the OPT PHASE COMP pot adjusted for a best-looking square wave as observed on an oscilloscope in REPRO MONITOR.

Another distortion attributable to the recording process is that associated with saturation of the oxide particles. "Operating Level" refers to a flux level, usually between 12 and 20dB below full tape saturation. Harmonic distortion of a sine wave signal at Op Level is typically well

well below 1%, but higher flux levels, including those representing program peaks, may approach the 3-5% distortion point.

The "linearizer" circuit of the 380 recording amplifier permits introduction of a corresponding amount of "pre-distortion" to the recording waveform. As in the case of the phase distortion correction circuit, the net effect of the pre-distortion and subsequent tape-generated distortion is a recorded signal with substantially less harmonic and intermodulation distortion at levels up to full tape saturation.

A wave-analyzer or IM distortion meter is required for this adjustment. The common "notch-type" of THD meter cannot be used to measure distortion in recording systems which have time-base instability. Even 0.1% flutter will sabotage THD readings. A 1kHz sine wave signal is recorded on the tape in the OPTIMIZED MODE at a level 3 to 6dB above Operating Level. The OPT LIN pot is adjusted for minimum third harmonic or IM as measured in REPRO MONITOR during recording.

Both the OPT PHASE COMP and the OPT LIN adjustments have sufficient range for a wide variety of magnetic oxides. When necessary test equipment for proper calibration is not available, it is best to leave both controls fully CCW so as to avoid possible introduction of more than normal tape-generated distortion.

"Pickup" (Insert) Record Timing

PICKUP TIMING adjustments R53 is located near the rear of the Record Board. This pot is adjusted for an erase/bias offset delay corresponding to the time that a point on the tape or film requires to travel from the erase to the record head. Approximate calibration figures assuming 15ips operation in HIGH SPEED and OPTIMIZED MODE are etched onto the board. The delay automatically doubles in LOW SPEED.

A more accurate adjustment can be made by monitoring pin 1 of IC4 with Channel 1 of a dual-trace oscilloscope, and the collector of Q10 with Channel 2. When the 380 enters the RECORD mode, Channel 1 will toggle from +18 to -18 volts; then after the pickup delay, Channel 2 will toggle from +18 volts to ground.

VI. CIRCUIT DESCRIPTIONS

Reproduce Board; A/N 157900, Schematic 158000

This assembly contains the head preamplifier for the normal REPRO mode, the equalized gain stage which serves both normal REPRO and SYNC playback, the output line-drive amplifier and monitor switching logic.

Q1 is a low-noise, matched pair of conventional NPN junction transistors. It is connected in an unequalized, feedback-pair configuration, and is the low level reproduce head preamplifier. Gain of this preamp is established by resistors R4, 5, 6 and 7, which may be jumpered for four gain settings; two for nominal Hi-Z heads and two for Lo-Z heads.

All low-level signal switching in the 380 is performed by quad, CMOS analog switch gates. These gates, referenced on the schematic as A1, 2, 3, etc., are operated between the $\pm 7.5V$ logic power supply rails in order to pass ground-referenced AC waveforms at levels up to about +10dBmV. Gates "open" with -7.5V applied to the control head and "close" to pass the audio signal when +7.5V is applied. Terminology in this case is switch contact oriented.

When A4/11-10 closes, output of the Q1 REPRO preamp is fed to the equalizing amplifier comprised of IC1B and associated circuitry. Alternately, A1/3-4 can pass a similarly-preamplified signal from the record head in SYNC playback. R14 and 15 are level calibration pots for either LOW/HIGH SPEED or OPTIMIZED MODE, depending on equalization switching logic from the Record Board and whether A1/8-9 or A1/11-10 is closed.

With C7 in the primary feedback path, IC1B is an integrating amplifier. HF pots R24-27 put a "shelf" in the integrating characteristic for control over high frequency equalization. LF pots R21-23 shunt C7 to shelve integration at low frequencies per selected equalization. Also in the feedback loop is the "bridged-T" network made up of R34 and 35 with C9 and 10. Alone in the feedback path, this network would cause IC1B to oscillate at about 22kHz. GAP LOSS EQUAL pots R30-33 spoil the "Q" of the network, however, giving a controllable "peak" at the resonant frequency to compensate for short wavelength reproduce head gap loss. C8 is switched into the feedback of IC1B in AUTO MUTE, attenuating both REPRO and SYNC monitoring whenever the transport is not in PLAY.

The output of the equalizing amplifier is routed through the front-panel REPRO GAIN control to the output line-drive amplifier, IC2A and B. A5/11-10 and A5/3-4 select either REPRO/SYNC playback or INPUT MONITOR. A second-order, low-pass filter (R37 and 38 with C11 and 12) attenuates erase/bias leakage, etc. The filter is flat to about 25kHz. A5/2-1 is controlled by the "power-on-reset" circuit of Q6 and shunts MONITOR signals to ground for about 5 seconds after the 380 is first turned on.

IC2A and B are connected in a differential, bridged output amplifier configuration. Each section is buffered by a discrete, complementary emitter-follower pair to deliver the required current to the output load.

SPEED (equalization) logic is received from the Record Board as binary information and decoded by IC4B. The Q0, Q3 and Q1 decoder outputs each go "high" in LOW SPEED, HIGH SPEED and OPTIMIZED MODE, respectively.

The local MONITOR pushbuttons (or REMOTE line when all buttons are "out") present tri-state logic to dual comparator IC3. The input sees an "open" in INPUT MONITOR, a ground in REPRO MONITOR and 10k-Ohms-to-ground in SYNC MONITOR. The IC3A and B comparator outputs are, respectively, "high" and "high," "low" and "low," and "low and high" for these commands. These data are decoded by IC4A; Q0, Q1 and Q3 each go "high" in REPRO, SYNC and INPUT MONITOR, respectively.

Various gates and inverters combine MONITOR and SPEED switching logic to operate the appropriate analog gates for various modes of 380 operation.

The SYNC TRANSFER line goes "high" when the 380 enters RECORD to switch MONITOR from SYNC to INPUT. This is accomplished by inverter IC5B and "and" gates IC6C and D.

Record Board; A/N 158200, Schematic 158300

The 380 Line Input is fed directly to the active-balanced, differential input stage, IC1A; the INPUT GAIN trim pot adjusts for the nominal line level. IC1B, a low-pass filter, is flat to about 25kHz and attenuates out-of-band noise in the input signal.

From IC1B, the input signal is routed to the front-panel INPUT GAIN control and then to equalizer-driver IC2A. IC2B, with input capacitor C12, is an input-differentiating amplifier with an integrating feedback path through C13. The

net effect would be flat response were it not for HIGH FREQ EQUAL pots R18-20. These shelve the integrating characteristic to impart a high-end pre-emphasis with variable turn-over frequency. A mid-high-frequency "dip" is provided by R17, C10 and C11 to better match typical record equalization requirements. The low-end characteristic of this amplifier is "IEC" (flat) when gate A1/3-4 is open, and "NAB" when closed.

IC3B, an all-pass, phase-shift amplifier, can be adjusted to compensate for recording process phase distortion in the OPTIMIZED MODE (A2/9-8 closed).

IC3A is the constant-current, record head driver stage. In the OPTIMIZED MODE (A2/10-11 closed), the input resistance to this amplifier may be selectively shunted by the non-linear network R27, CR1 and CR2. This pre-distorts the input signal in a manner complementary to normal, tape-generated distortion.

The recording level FLUX ADJ trim pots are in the positive feedback loop of IC3A. Flux level is trimmed by R32 and 35, as selected by A2/2-1 and FET Q1, or by A2/3-4 and FET Q2. The FET appropriate to the selected flux level is "ramped-on" to give a quiet entry into RECORD. Record relay K1 transfers the recording head either to the output of the record amplifier in RECORD, or otherwise to the input of the SYNC amplifier.

Q17 is a feedback-pair, unequalized, low-noise gain stage for SYNC reproduce. It is very similar to the normal REPRO preamplifier, but includes R87, a variable SYNC MATCH gain control.

When the RECORD logic line from the Logic Board goes "high," output of IC4A goes to the negative supply rail. Two things occur at this point. The Miller Integrator erase amplifier power controller, Q4 and 5 with R47 and C20 providing integration, begins ramping up. The ramp takes about 100ms to reach the positive supply rail, and erase drive increases in direct proportion.

Concurrent with the RECORD command and the start of the erase ramp, a second integrator, IC4B, begins ramping from the negative to the positive supply rail. Slope of this integration is adjusted by PICKUP TIMING control R53. Time to reach 50% (zero volts) may be varied between 12 and 120ms in HIGH SPEED and OPTIMIZED MODE. In LOW SPEED, FET Q9 turns on, effectively doubling the integration period. When the output of IC4B reaches -7.5V, comparator IC6B toggles positive, giving a SYNC TRANSFER command to the MONITOR switching logic on the Reproduce Board. When the ramp

reaches mid-point, Q10 turns on and initiates the bias amplifier ramp. The PICKUP delay ramp continues to the positive supply rail however, so that a symmetrical "drop-out" delay occurs when leaving the RECORD mode.

Q11 and 12 with R62 and C31 form a second Miller Integrator for the bias supply. Just after the ramp-up begins, comparator IC6A toggles positive to energize the record relay. As the ramp-up continues, Q1 or 2 is allowed to turn on through either CR3 or 5. Depending on which FLUX level is selected, CR4 or 6 holds the other FET off.

The bias DC ramp is applied to the base of emitter-follower Q13 through R67, one resistor of a variable voltage-divider arrangement with the BIAS ADJ pots. When the appropriate pot is selected, the "bottom" of either R69 or 70 is pulled to the negative supply, enabling the pot to control the level of DC drive to the bias amplifier.

The 500kHz erase/bias "pilot" signal from the Logic Board, or from another, "Master" 380, is "digitally" divided by IC5 to obtain symmetrical square waves at 250 and 125kHz. The 125kHz square wave is amplified by Q6 to switch Q7 on and off at the erase frequency. Q8 is "bootstrapped" to Q7, and the two transistors form a "Class-S" power switching amplifier. The output of this amplifier is a symmetrical square wave with a peak-to-peak amplitude equal to the total supply voltage (about 35V p-p) when the erase DC ramp reaches full value. L1, the erase head and appropriate C26-29 tuning capacitance form a high-"Q", "quasi-half-T-section." This transforms the low impedance square wave drive to a high voltage, low distortion sine wave erase source.

The 250kHz signal is similarly amplified by Q14, 15 and 16, but to a peak-to-peak value established by the BIAS ADJ pots. L2, L3 and C36 provide the necessary impedance transformation. Purity of the bias waveform is assured by the high "Q" of the tuned circuit and binary division of the pilot signal. L4/C38 and L5/C39 are parallel and series traps to keep bias out of the record and SYNC amplifiers.

A "power-on-reset" circuit, Q3, holds the erase and bias circuitry off for a few seconds after AC power is first applied to the 380.

SPEED (equalization) selection is made by the front-panel buttons or, if all buttons are "out," by a transport SPEED switch, if provided. The REMOTE SPEED bus is a two-way, tri-state line; either grounded, open or at +4 volts, corresponding to LOW SPEED, HIGH SPEED or OPTIMIZED MODE,

respectively. With the front-panel buttons "out," the line receives this logic from the tape transport or from another 380 used as "master." When the buttons are actuated, not only does this take priority over remote commands, but the logic is sent to any interconnected "slave" unit.

Local or remote SPEED logic is decoded by comparators IC7A and B. Outputs are "low" and "low," "high" and "high," and "high" and "low" for LOW SPEED, HIGH SPEED and OPTIMIZED MODE, respectively. IC8A further decodes SPEED logic, the Q0, Q3 and Q1 outputs "high" in LOW, HIGH and OPTIMIZED, respectively. This directly controls the analog gates for equalization and level selection. IC8B is connected as an inverter for proper logic to the PHASE COMP circuit. Diodes CR26-28 create an "or" gate for the "L, H and O" straps to select the proper low-end record characteristic.

IC9, yet another decoder and level shifter, provides the necessary high-level logic to FET switches and the BIAS ADJ circuit. IC9B toggles "high" in LOW and HIGH SPEED, IC9A in OPTIMIZED MODE.

Logic Board; A/N 158600, Schematic 158700

The POWER switch and triac Y1 control primary AC power to the 380 and to the transport if it derives AC power from the electronics.

The erase/bias pilot oscillator consists of inverters IC4D and E and a "ceramic resonator," P1. IC1A and B form a free-running, 1Hz multivibrator. The two oscillator outputs are combined and buffered by Q8 and 9. The low-frequency component is used to flash the red meter lights in READY. The two frequencies are sufficiently far removed from one another that very simple low- and high-pass filters keep them separated.

Transport logic is isolated from ground-referenced 380 logic by a series of opto-isolators. Whenever the transport is in PLAY, OC1 is turned on. IC1E defeats the AUTO MUTE function, if selected, and the combination of IC1D, IC2A, IC3B and IC3A flashes the red meter lights at a 1Hz rate when the 380 is in READY. The flashing rate is picked off the bias pilot signal by LPF R14/C3.

Q4 is the RECORD "switch." When the 380 is READY (OC2 on and Q2 held off), Q4 may be turned on, either by a command to the base or by having the PLAY and RECORD lines momentarily shorted. This also turns on Q3 which holds Q4 on

and turns on OC3. OC3, IC1F and IC1C supply RECORD logic to the Record Board and change the flashing red meter lights to a steady red indication.

Output from the line drive amplifier is supplied to the "precision" rectifier circuit of IC5. The resultant full-wave-rectified signal drives the "VU" meter when S2 is switched to "VU." CR11, R41 and R50 provide scale linearity correction and proper meter damping.

R40 and C11 integrate the rectified output signal per the UK/EBU "PPM" specification. A unity-gain buffer, IC6B, holds the final value for a period established by the IC6A "holdoff" circuit. C11 can quickly discharge through CR13 when the output of IC6A goes negative, but this point is held positive for a short period each time the measured value is updated by a higher peak level. The "holdoff" time, established by C10 and R42, complements risetime of the meter movement. Signal differentiation by C12 further "subtracts" from movement risetime.

When S2 is switched to ERASE, the meter monitors rectified erase drive.

Power Supply; A/N 158900, Schematic 159000

The 380 power supply utilizes variable positive and negative "3-terminal" voltage regulators. These are self-protecting against output or thermal overloads. The output voltage is fixed by the voltage-divider between the output and common terminals. The outputs are $\pm 18V$ for amplifier, bias and high-level logic, and $\pm 7.5V$ for CMOS logic circuitry. The power supply circuit board also contains the front-panel INPUT and REPRO GAIN controls.

VII. APPENDIX

SCHEMATIC REFERENCE	INOVOONICS PART NO.	COMPONENT DESCRIPTION	MANUFACTURER AND MFR'S PART NO.
<u>REPRODUCE BOARD</u> - Assembly 157900, Schematic 158000			
A1-5	1335	CMOS Analog Switch Gate	RCA CD4066 BE
C1	0822	Capacitor, Mica 1000pF	Arco DM19-102J
C2	1069	Electrolytic 220uF, 6.3V	Elna type RL - 220/6.3
C3	0806	Mica 47pF	Arco DM15-470J
C4	0920	Electrolytic 100uF, 25V	Elna type RL - 100/25
C5, 17	1054	Tantalum 4.7uF, 25V	NEC NDD475M25C
C6	1067	" 1.0uF, 35V	" NDA105M35C
C7, 9	0863	Mylar .022uF, 100V	Sprague 225P 22391
C8, 10	0867	" .1uF, 100V	" 225P 10491
C11	0820	Mica 680pF	Arco DM19-681J
C12	0827	" 300pF	" DM15-301J
C13, 16	0810	" 100pF	" DM15-101J
C14, 15	1053	Tantalum 2.2uF, 25V	NEC NDB225M25C
CRL-11	1100	Diode, silicon signal	GI 1N4151
IC1, 2	1314	Integrated Circuit	Signetics NE5535N
IC3	1313	"	Raytheon RC4558NB
IC4	1348	"	RCA CD4555BE
IC5	1336	"	RCA CD4069BE
IC6	1342	"	RCA CD4081BE
Q1	1237	Transistor, dual low-noise	Nat'l LM394
Q2, 4	1204	" NPN	" 2N3567
Q3, 5, 6	1205	" PNP	" 2N3645

NOTE: Unless otherwise specified, all fixed resistors are carbon film type, value and wattage per schematic. Variable resistors are multi-turn (Spectrol 43P, Beckman 89PR, etc.), value per schematic.

SCHEMATIC REFERENCE	INOVOONICS PART NO.	COMPONENT DESCRIPTION	MANUFACTURER AND MFR'S PART NO.
R2	0564	Resistor, variable 200k	Beckman Helipot 91AR 200K
S1	1843	Switch, multi-station pushbutton	Schadow 5XFA-15-FA201
<u>RECORD BOARD - Assembly 158200, Schematic 158300</u>			
A1,2	1335	CMOS Analog Switch Gate	RCA CD4066BE
C1,2,3,4	1053	Capacitor, Tantalum 212uF, 25V	NEC NDB225M25C
C5,6,8,17,22,33,37	0810	" Mica 100pF	Arco DM15-101J
C7	0814	" " 220pF	" DM15-221J
C9	1068	" Tantalum 22uF, 3V	NEC NDC226M03C
C10,13,24,25,34,35	0862	" Mylar .01uF, 100V	Sprague 225P 10491
C11	0873	" " .015uF, 100V	" 225P 15491
C12	0854	" " .0022uF, 100V	" 225P 22291
C14	0850	" " .001uF, 100V	" 225P 10291
C15,19,41,44,47	1054	" Tantalum 4.7uF, 25V	NEC NDD475M25C
C16	0856	" Mylar .0033uF, 100V	Sprague 225P 33291
C18,23	1071	" Tantalum 22uF, 25V	NEC NDK226M25C
C20,30,31	0867	" Mylar .1uF, 100V	Sprague 225P 10491
C21,32,40	1067	" Tantalum 1.0uF, 35V	NEC NDA105M35C
C26	0829	" Mica 3000pF	Arco DM19-302J
C27	0834	" " 2700pF	" DM19-272J
C28	0833	" " 2400pF	" DM19-242J
C29	0831	" " 510pF	" DM19-511J
C36	0838	" " 910pF	" DM19-911J
C38	0820	" " 680pF	" DM19-681J
C39	0818	" " 470pF	" DM19-471J
C42	0822	" " 1000pF	" DM19-102J
C43	1069	" Electrolytic 220uF, 6.3V	Elna type RL - 220/6.3

SCHEMATIC REFERENCE	INOVOONICS PART NO.	COMPONENT DESCRIPTION	MANUFACTURER AND MFR'S PART NO.
C45	0806	Capacitor, Mica 47pF	Arco DM15-470J
C46	0920	" Electrolytic 100uF, 25V	Elna type RL - 100/25
CR1-23,25, 26,27,28	1100	Diode, silicon signal	GI 1N4151
CR24	1111	" zener 3.6V	Motorola 1N5227
IC1,2,3	1314	Integrated Circuit	Signetics NE5535N
IC4,6,7,9	1313	"	Raytheon RC4558NB
IC5	1322	"	RCA CD4013AE
IC8	1348	"	RCA CD4555BE
K1	1904	Relay, SPDT - "Dip" 12V coil	Sigma 191TE1C1-12G
L1,2,3,5	1403	Inductor, 1mH	Delevan 2500-28
L4	1401	" 560uH - shielded	Nytronics SWD 560
Q1,2,9	1230	Transistor, N-chan FET	Siliconix J111
Q3,4,11	1205	" PNP	Nat'l 2N3645
Q5,7,8,13, 15,16	1236	" Power NPN	Motorola MJE180
Q6,10,12, 14	1204	" NPN	Nat'l 2N3567
Q17	1237	" dual low-noise	Nat'l LM394
		<u>NOTE:</u> Unless otherwise specified, all fixed resistors are carbon film type, value and wattage per schematic. Variable resistors are multi-turn (Spectrol 43P, Beckman 89PR, etc.), value per schematic.	
R53	0559	Resistor, variable 10K	Heckman Helipot 91AR 10K
S1	1843	Switch, multi-station pushbutton	Schadow 5XFA-15-FA201
S2	1842	" pushbutton	" FG-RED-2U-0A

SCHEMATIC REFERENCE	INOVONICS PART NO.	COMPONENT DESCRIPTION	MANUFACTURER AND MFR'S PART NO.
LOGIC BOARD - Assembly 158600, Schematic 158700			
C1, 2, 4, 5, 12	1053	Capacitor, Tantalum 2.2uF, 25V	NEC NDB225M25C
C3	1054	" " 4.7uF, 25V	" NDD475M25C
C6	0806	" Mica 47pF	Arco DM15-470J
C7	0810	" " 100pF	" DM15-101J
C8, 10, 11	1067	" Tantalum 1.0uF, 35V	NEC NDA105M35C
C9	0862	" Mylar .01uF, 100V	Sprague 225P 10391
CR1, 4	1105	Diode, zener 12V	Motorola 1N5242
CR2, 3, 7	1125	" rectifier	" 1N4005
CR5, 6, 8-17	1100	" silicon signal	GI 1N4151
IC1, 4	1336	Integrated Circuit	RCA CD4069BE
IC2, 6	1313	" "	Raytheon RC4558NB
IC3	1342	" "	RCA CD4081BE
IC5	1314	" "	Signetics NE5535N
P1	1410	Ceramic Resonator, 500kHz	RMC CR30-FA / 500K
Q1, 3	1226	Transistor, NPN	Motorola MPSA42
Q2, 7, 8	1204	" "	Nat'l 2N3567
Q4	1225	" "	Motorola MJE350
Q5, 6	1232	" NPN Darlington	" MPSA14
Q9	1205	" PNP	Nat'l 2N3645
NOTE: Unless otherwise specified, all fixed resistors are carbon film type, value and wattage per schematic.			
R39	0563	Resistor, variable 100K	Beckman Helitrim 91AR 100K
R48	0560	" " 20K	" " 91AR 20K

SCHEMATIC REFERENCE	INOVONICS PART NO.	COMPONENT DESCRIPTION	MANUFACTURER AND MFR'S PART NO.
S1	1841	Switch, pushbutton	Schadow FG-EE-FG/WHT
S2	1826	" 2-pole, 3-position	Cont. Wirt G-128-S / G-20-18
Y1	1152	Triac	RCA T2500B
<u>POWER SUPPLY BOARD</u>		- Assembly 158900, Schematic 159000	
C1,2	0910	Capacitor, Electrolytic 470uF, 50V	Elna type TE - 470/50
C3-6	1053	" Tantalum 2.2uF, 25V	NEC NDB225M25C
CR1-8	1125	Diode, rectifier	Motorola 1N4005
IC1,3	1373	Integrated Circuit, positive regulator	Nat'l LM317
IC2,4	1374	" negative	" LM337
		NOTE: Unless otherwise specified, all fixed resistors are carbon film type, value and wattage per schematic.	
R9,14	0621	Resistor, variable 10K	Allen Bradley 21M606-10K
-	2505	Knob (2)	Raytheon 70-2WD-2G
<u>CHASSIS COMPONENTS</u>		(Exclusive of those associated with various Mother Boards)	
I1,2,3	2012	Meter Lamp (I1 & 2 are painted RED)	GE 387
M1	2808	Meter, "Simulated VU" (DC movement)	Dixson 301-K / 200uA w/ "VU" scale
T1	159700	Transformer, Power	Inovonics O.E.M. part
T2	109000	" Output	" "

SCHEMATIC REFERENCE	INOVONICS PART NO.	COMPONENT DESCRIPTION	MANUFACTURER AND MFR'S PART NO.
MOTHER BOARD (For Ampex and Similar Transports) Assembly 159200, Schematic 159300			
C1, 2	0872	Capacitor, Mylar .01uF, 600V	Sprague 6PS-S10
F1	2706	Fuse, 3-AG - 3A	Buss or Littlefuse
F2	2702	" " 1/2A	" "
J1	1644	Connector, 6-pin "Jones" Female	Cinch S306-AB
J2	1640	" " 10-pin " Male	" P310-AB
J3, 5, 9	1717	" " 6-pin Male	Molex 09-60-1061
J4	1686	" " 16-pin "DIP"	Burndy DILB16-11T
J6, 7, 8	1715	" " 22-pin P.C.	Edac 356-022-250-01
J6A	1719	" " 3-pin Female	Molex 09-52-3030
J10	1601	" " 1-pin "MS" Male	Amphenol 3102A10S-2P
J11	1602	" " 2-pin "MS" "	" 3102A10S-4P
J12	1603	" " 3-pin "MS" "	" 3102A10S-3P
J13	1610	" " 3-pin "XLR" Female	Switchcraft D3F
J14	1609	" " " Male	" D3M
R1	0064	Resistor, 1/4W, 5% carbon film 1.5K	

SCHEMATIC REFERENCE	INOVONICS PART NO.	COMPONENT DESCRIPTION	MANUFACTURER AND MFR'S PART NO.

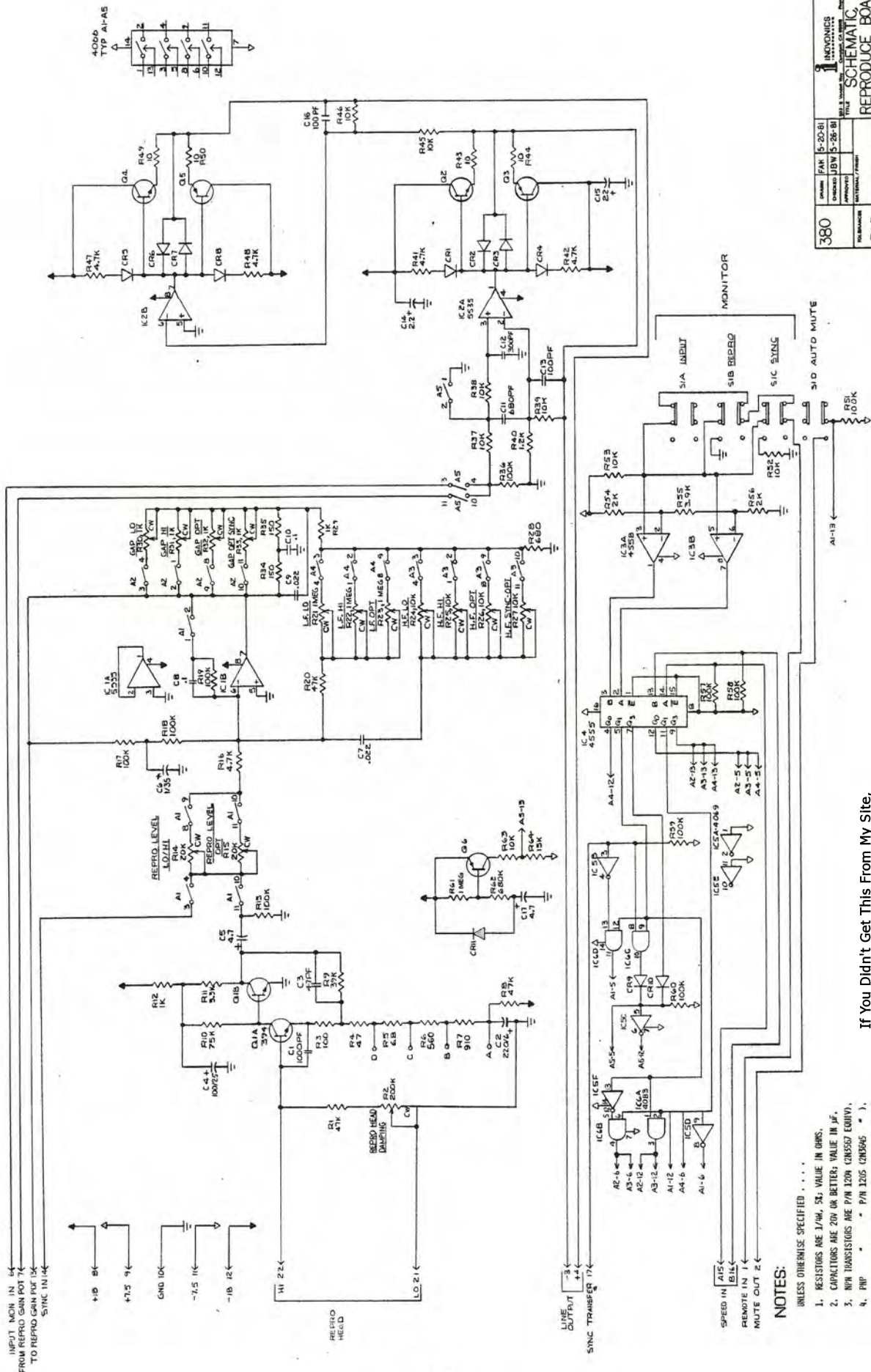

380	PAK 5-20-81	INOVONICS
UNION	UNION 5-28-81	REPRODUCE BOARD
DATE	DATE	DATE
1-1	158000	A

If You Didn't Get This From My Site,
Then It Was Stolen From...
www.SteamPoweredRadio.Com

- NOTES:
- UNLESS OTHERWISE SPECIFIED
1. RESISTORS ARE 1/4W, 5% VALUE IN OHMS.
 2. CAPACITORS ARE 20V OR BETTER; VALUE IN μ F.
 3. NEW TRANSISTORS ARE P/N 1204 (NPN) EQUIV.,
 4. PNP " " " P/N 1205 (NPN) EQUIV. (),
 5. DIODES ARE P/N 1N11 (1N11) EQUIV. (),
 6. DIODES ARE P/N 1N100 (1N100) EQUIV. ().

TO SHEET 1

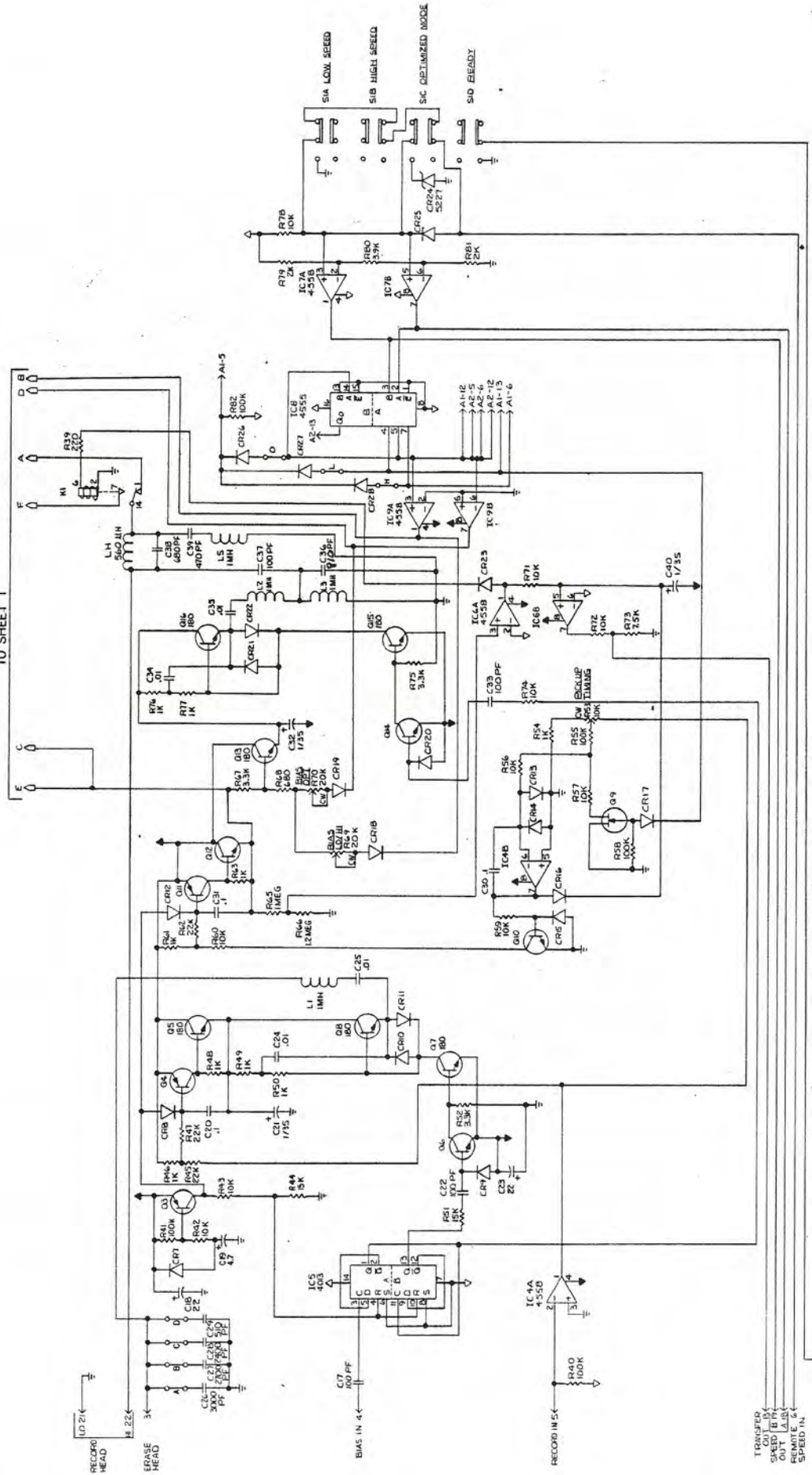

NOTES:

- 1. RESISTORS ARE 1/4W, 5% VALUE IN OHMS.
- 2. CAPACITORS ARE 20V OR BETTER, VALUE IN μ F.
- 3. NPN TRANSISTORS ARE P/N 1206 (CIR555) EQUIV.
- 4. PNP " " " P/N 1205 (CIR545 " ").
- 5. FET " " " P/N 1211 (CIR 11 " ").
- 6. DIODES ARE P/N 1100 (1N915) EQUIV.

If You Didn't Get This From My Site,
Then It Was Stolen From...
www.SteamPoweredRadio.Com

380	NAME	FAK 5-20-81	DATE	REV	BY
	DESIGNED	UBW 5-26-81			
	APPROVED				
	DATE				
	TOLERANCES				
	SCALE				
	PROJECT NO.	158300			
	SHEET	2	OF	2	
	REV				
	BY				
	CHECKED				
	APPROVED				
	DATE				

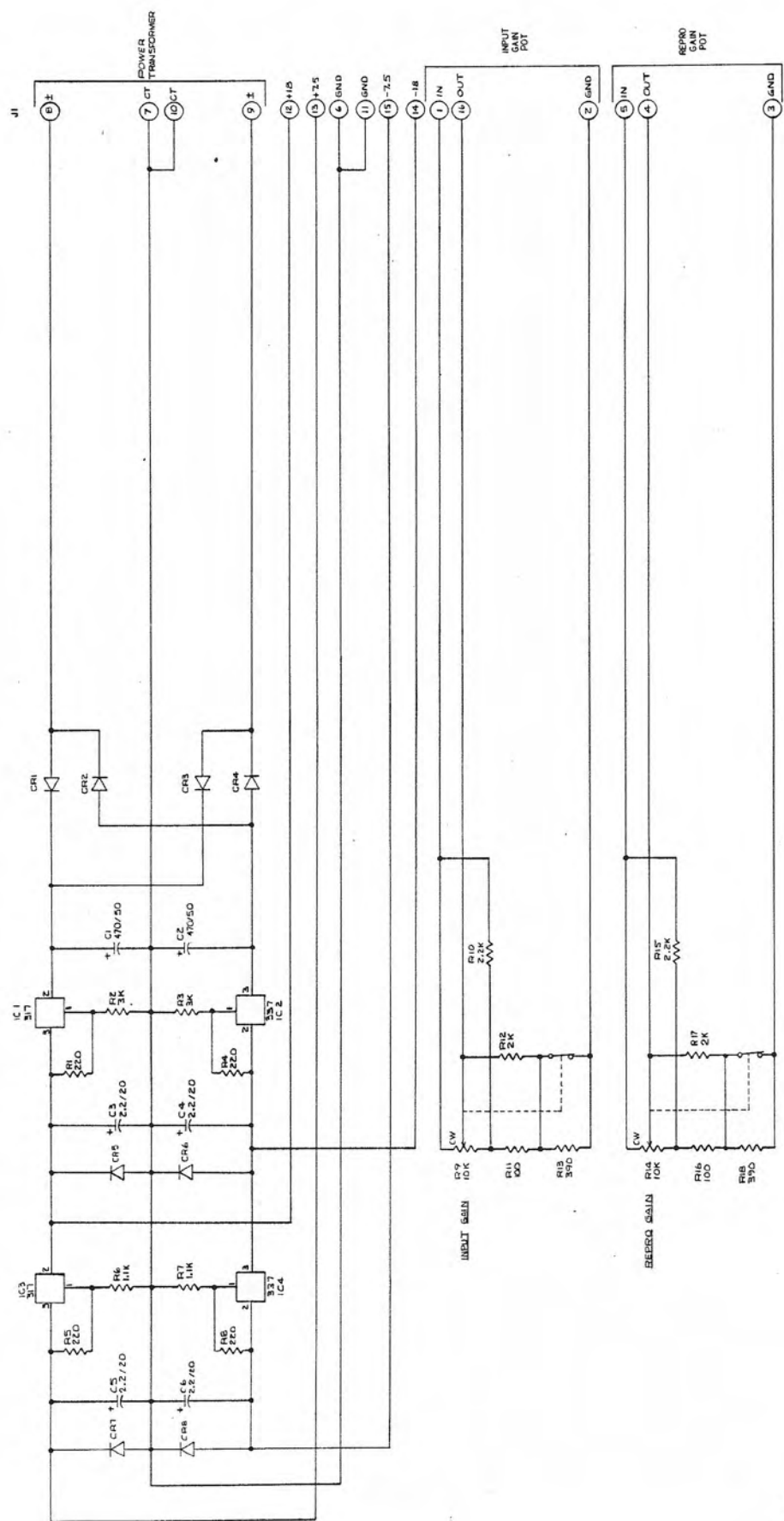

380	REV. 1	5-20-81	INNOVONICS
DATE	REV.	BY	APP'D.
5-20-81	1	J. J. J.	J. J. J.
TITLE: SCHEMATIC			
POWER SUPPLY BD.			
SCALE	1:1	DATE	159000
BY	J. J. J.	CHK'D	A

If You Didn't Get This From My Site,
Then It Was Stolen From...

www.SteamPoweredRadio.Com

- NOTES:
- UNLESS OTHERWISE SPECIFIED
 - RESISTORS ARE 1/4W, 5%, VALUE IN OHMS.
 - CAPACITORS ARE 20V OR BETTER, VALUE IN μ F.
 - NEW TRANSISTORS ARE P/N 1204 (2N5567 EQUIV).
 - PNP P/N 1205 (2N6905 . . .).
 - FET P/N 1211 (MPF 111 . . .).
 - DIODES ARE P/N 1125 (1N4005 EQUIV).

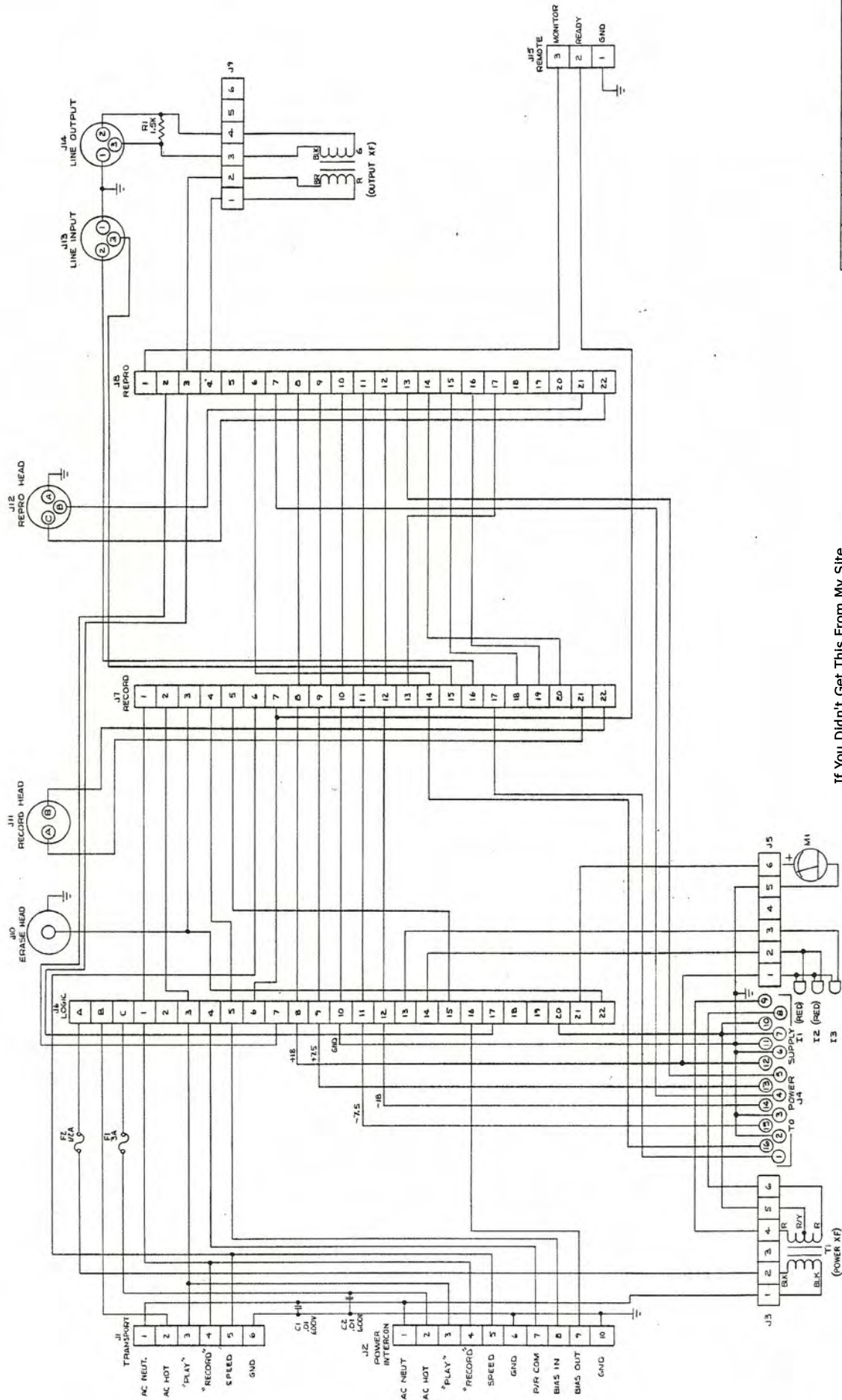

380	DATE	FAK 5-20-81	DESIGNED BY	JEW 5-28-81	CHECKED BY	JEW
	APPROVED					
	TITLE	SCHEMATIC CHASSIS, AMPEX AND SIMILAR			FIG. NO.	159300
	REV.	1	OF	1		A

If You Didn't Get This From My Site,
Then It Was Stolen From...
www.SteamPoweredRadio.Com

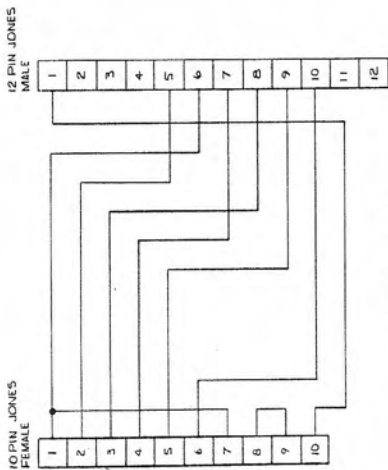

AMPEX 300

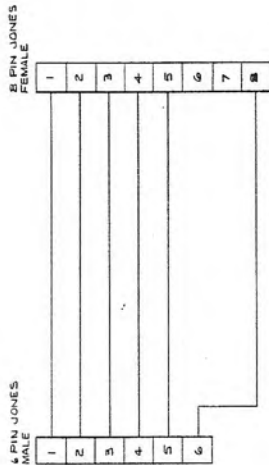

AMPEX AG-350 ADAPTER

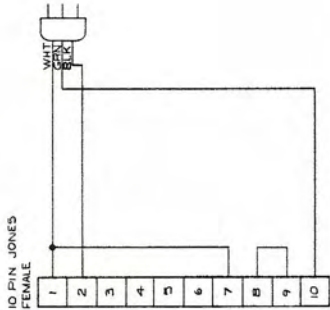

AMPEX 351

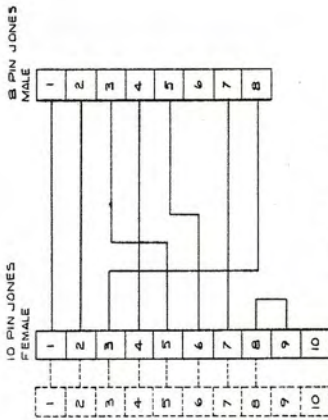

AMPEX AG-440

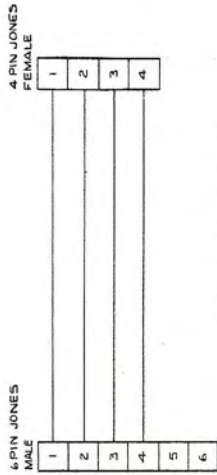

AMPEX 350 ADAPTER

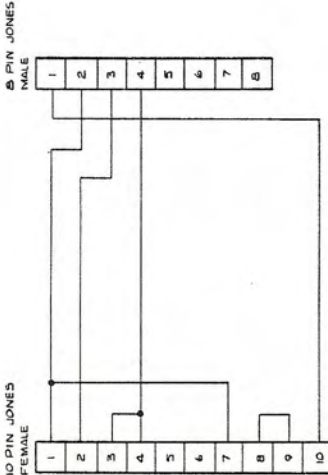

AMPEX FR-1100

DATE	370	REV	4-20-98	NO. OF	9
CHECKED	380	APPROVED	4-23-98	BY	INTERCONNECT
MATERIALS		CABLES		DATE	
				16/200	A

If You Didn't Get This From My Site,
Then It Was Stolen From...
www.SteamPoweredRadio.Com

INOVONICS WARRANTY

Inovonics, Inc. products are warranted to be free from defects in material and workmanship. Any discrepancies noted within 90 days of the date of purchase will be repaired free of charge. Additionally, parts for repairs required between 90 days and one year from the date of purchase will be supplied free of charge, with installation billed at normal rates. It will be the responsibility of the purchaser to return equipment for warranty service to the dealer from whom it was originally purchased unless prior arrangement is made with the dealer to inspect or repair at the user's location.

This warranty is subject to the following conditions:

1. Warranty card supplied with the equipment must be completed and returned to the factory within 10 days of purchase.
2. Warranty is void if unauthorized attempts at repair or modification have been made, or if serial identification has been defaced, removed, or altered.
3. Warranty does not apply to damage caused by misuse, abuse, or accident.
4. Warranty valid only to original purchaser.



-If You Didn't Get This From My Site,
Then It Was Stolen From...

www.SteamPoweredRadio.Com