

Instructions



TYPE AIRS INDUCTION-VOLTAGE REGULATOR

FOR INDOOR SERVICE

GENERAL  ELECTRIC

TABLE OF CONTENTS

	PAGE
GENERAL DESCRIPTION OF REGULATOR	5
GENERAL DESCRIPTION OF CONTROL	8
SHIPMENT	13
STORAGE	13
INSTALLATION	13
Regulator Connections	13
Grounding	14
Checking Direction of Rotation	14
Contact-making Voltmeter	14
Alignment of Contacts	14
Adjustment of Contact-making Voltmete	14
MAINTENANCE AND INSPECTION	16
Contact-making Voltmeter	16
Motor-control Relay	18
Miscellaneous	21
Inspection (Small kva sizes)	22
Disassembly (Small Kva Sizes)	22
Reassembly	23
Adjustment of Regulator Rotor Bearings	24
Adjustment of Worm Bearings	24
Inspection (Large kva sizes)	24
Motor	24
Limit Switch	24
Disassembly	26
Adjustment of Regulator Rotor Bearings	26
Adjustment of Worm Bearings	28
Reassembly	28
TESTS	29
REPAIRS	30
RENEWAL PARTS	30

LIST OF ILLUSTRATIONS

FIG.	PAGE
1. Typical connection diagram of regulator and auxiliaries (small kva sizes)	4
2. Typical connection diagram of regulator and auxiliaries (large kva sizes).....	5
3. Schematic diagram of Fig. 1.....	6
4. Schematic diagram of Fig. 2.....	7
5. Schematic diagram of hand-operated regulators.....	8
6. Sectionalized view of the small kva-size regulator.....	9
7. Sectionalized view of the large kva-size regulator.....	10
8. Type TSB-20 contact-making voltmeter.....	11
9. Motor-control relay.....	11
10. Control panel.....	12
11. Limit switch.....	13
12. Alignment of contact-making-voltmeter contacts.....	15
13. Sectionalized view of Type TSB-20 contact-making voltmeter.....	15
14. Contact-making-voltmeter beam assembly.....	15
15. Contact-making-voltmeter front-pivot bearing.....	18
16. Motor-control relay.....	19
17. Assembly of moving contact to armature on motor-control relay.....	20
18. Connections of motor-control relay.....	21
19. Method used to remove worm gear (small kva).....	22
20. Location of windings (small kva).....	23
21. Method used to assemble worm gear (small kva).....	23
22. Adjustment of regulator rotor bearings (small kva).....	25
23. Method used to preload worm bearings (small kva).....	25
24. Method used to remove worm gear (large kva).....	26
25. Location of windings (large kva).....	27
26. Method used to assemble worm gear (large kva).....	28
27. Method used to preload worm bearings (large kva).....	29

These instructions do not purport to cover all details or variations in equipment nor to provide for every possible contingency to be met in connection with installation, operation or maintenance. Should further information be desired or should particular problems arise which are not covered sufficiently for the purchaser's purposes, the matter should be referred to the General Electric Company.

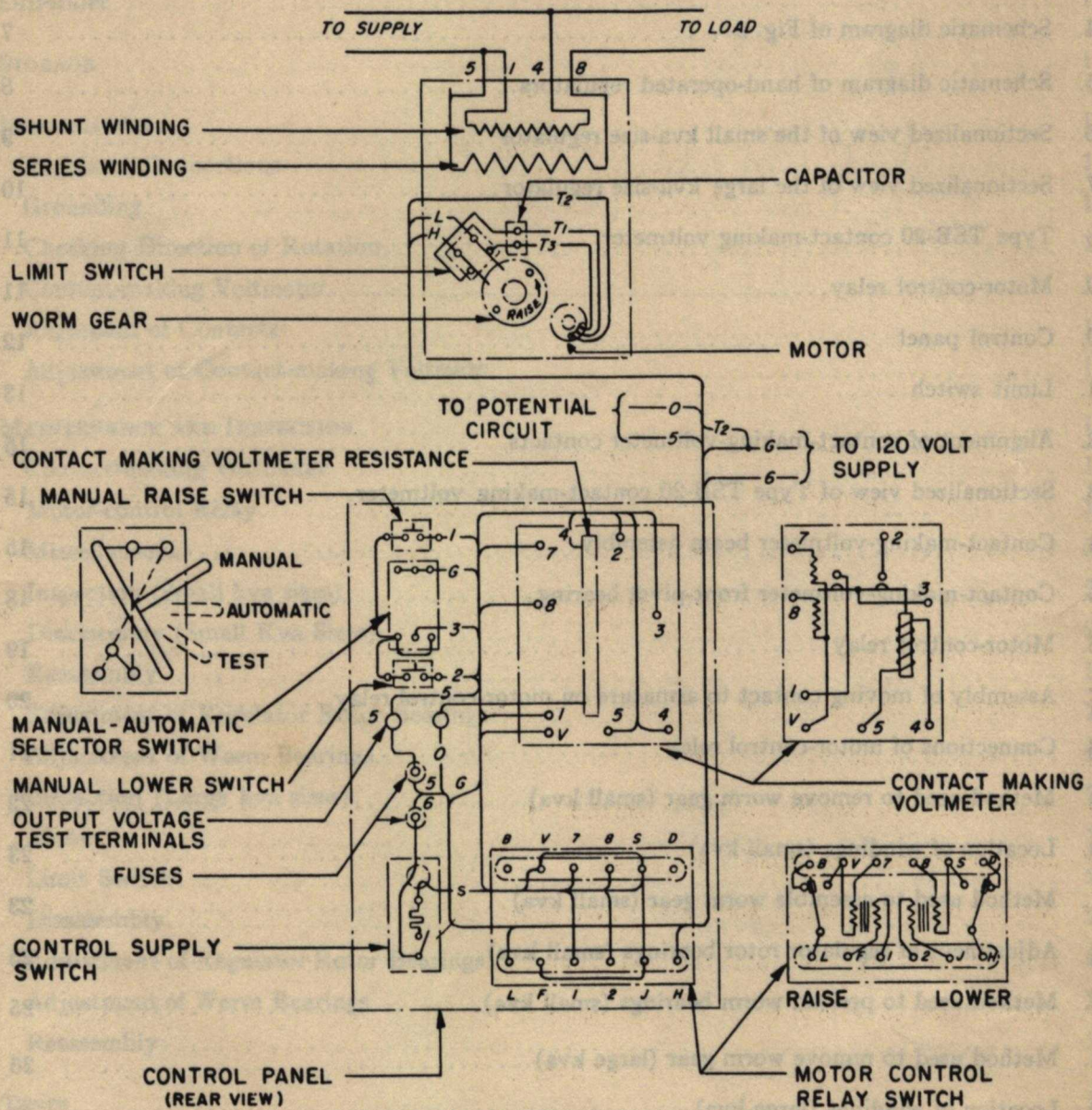

Fig. 1. Typical connection diagram of regulator and auxiliaries (small kva sizes)

TYPE AIRS INDUCTION-VOLTAGE REGULATOR FOR INDOOR SERVICE

The Type AIRS induction-voltage regulator is a device for automatically maintaining voltage of electrical circuits within predetermined limits. The regulator consists of a movable rotor, on

which is wound the shunt winding to be connected across the line, and a stator on which is wound a series winding to be connected in series with the line to be regulated. The voltage in-

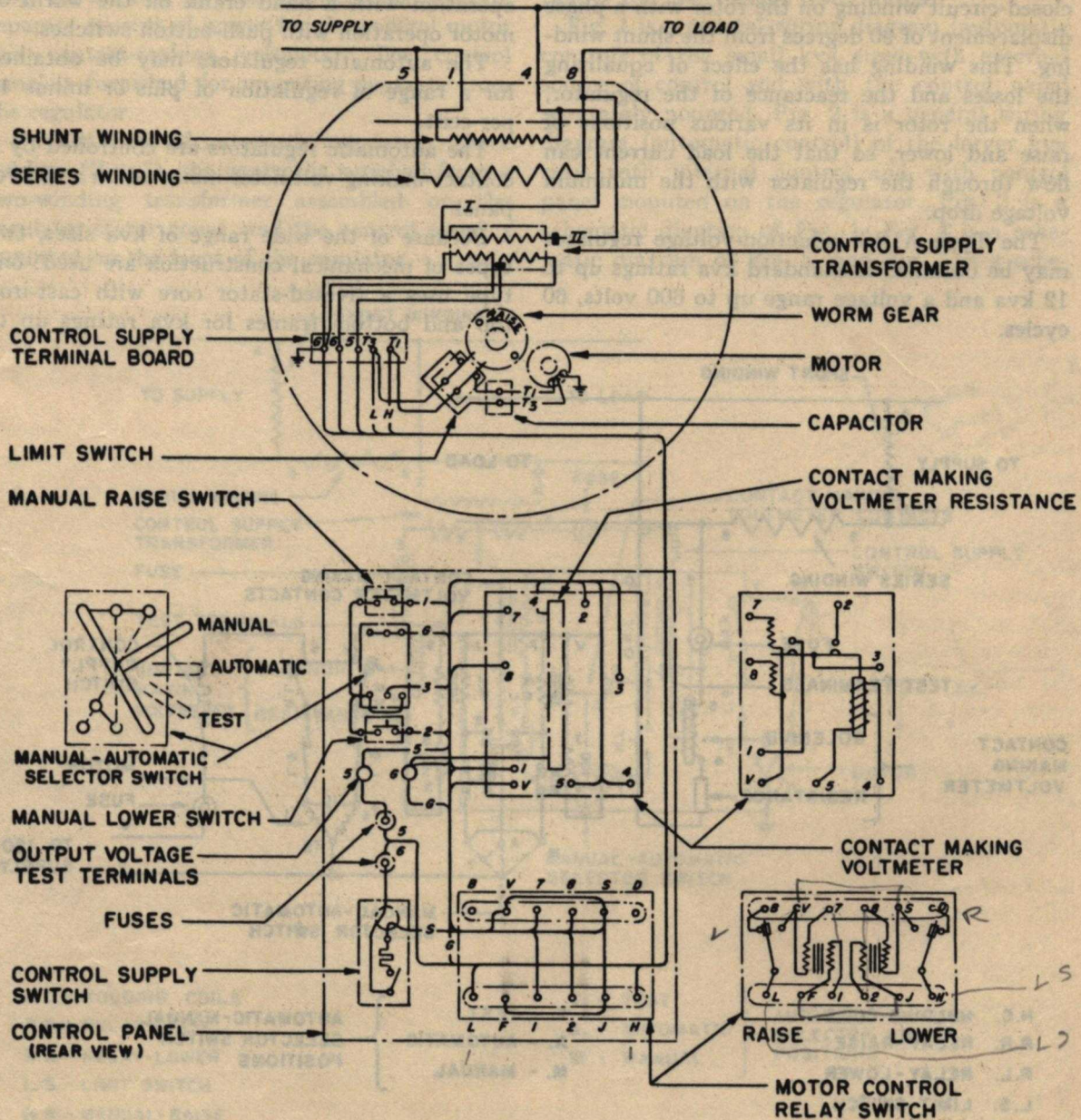

Fig. 2. Typical connection diagram of regulator and auxiliaries (large kva sizes)

GEH-1085B Induction-voltage Regulator, Type AIRS

duced in the series winding and, therefore, the amount of voltage which is added or subtracted with respect to the line voltage may be varied by changing the position of the rotor relative to the stator.

In addition to the shunt winding there is a closed-circuit winding on the rotor with a phase displacement of 90 degrees from the shunt winding. This winding has the effect of equalizing the losses and the reactance of the regulator, when the rotor is in its various positions of raise and lower, so that the load current can flow through the regulator with the minimum voltage drop.

The Type AIRS induction-voltage regulator may be obtained in standard kva ratings up to 12 kva and a voltage range up to 600 volts, 60 cycles.

There is a wide range of usage for this type of regulator. They may be used for testing purposes with a short-time duty cycle of one hour and with a range of regulation up to 100 per cent lower to 200 per cent raise. The testing-type regulator may be arranged for operation with a hand crank on the worm or motor operation with push-button switches.

The automatic regulators may be obtained for a range of regulation of plus or minus 10 per cent.

The automatic regulators are controlled by a contact-making voltmeter mounted on a control panel.

Because of the wide range of kva sizes, two types of mechanical construction are used: one type uses a riveted-stator core with cast-iron top and bottom frames for kva ratings up to

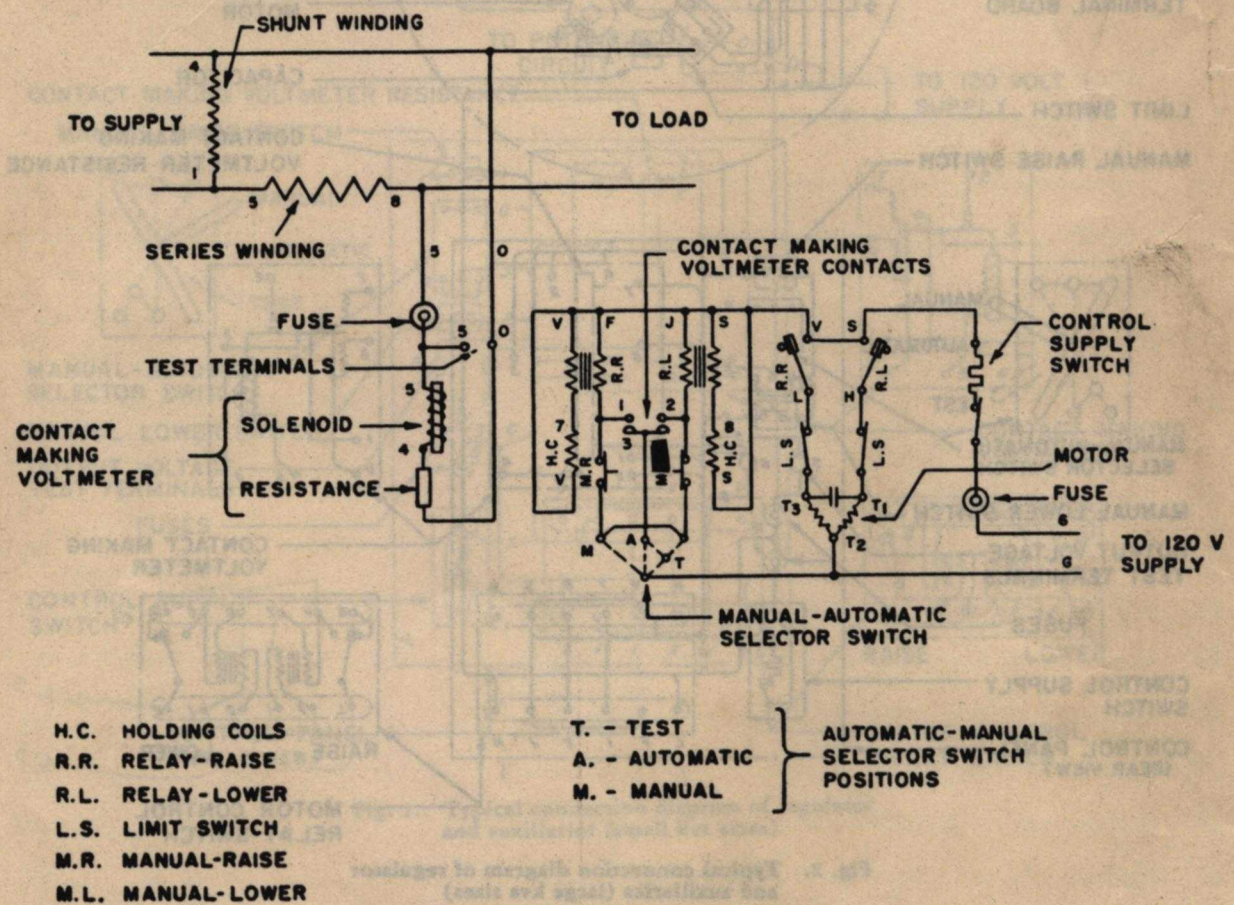

Fig. 3. Schematic diagram of Fig. 1

Induction-voltage Regulator, Type AIRS GEH-1085B

6.0 kva short-time duty; the other has a welded-type construction, similar to that used on the interior of the oil-filled induction regulators for larger kva sizes. These two types of constructions are shown in Fig. 6 and 7.

Automatic regulators up to 3.6 kva sizes (Fig. 6), because of their physical size, require separate sources of power for the control motor and contact-making voltmeter. The control panel is furnished for mounting separate from the regulator.

On kva sizes of automatic regulators above 3.6 kva (Fig. 7), the control is supplied from a two-winding transformer assembled on the regulator-stator cover, and the control panel is mounted on the front of the regulator.

The automatic operation of these regulators is controlled by a contact-making voltmeter, which responds to changes in the load voltage and in conjunction with a motor-control relay, causes the operating motor to rotate the regulator rotor to the position required to correct a deviation of the line voltage from normal.

Fig. 1 is a general wiring diagram (automatic control) of the small kva sizes with external source of control and with the control panel separately mounted. Fig. 2 is a general wiring diagram (automatic control) of the larger kva sizes with internal control and with control panel mounted on the regulator. Fig. 3 is a schematic diagram of Fig. 1; Fig. 4 is a schematic diagram of Fig. 2, and Fig. 5 is a sche-

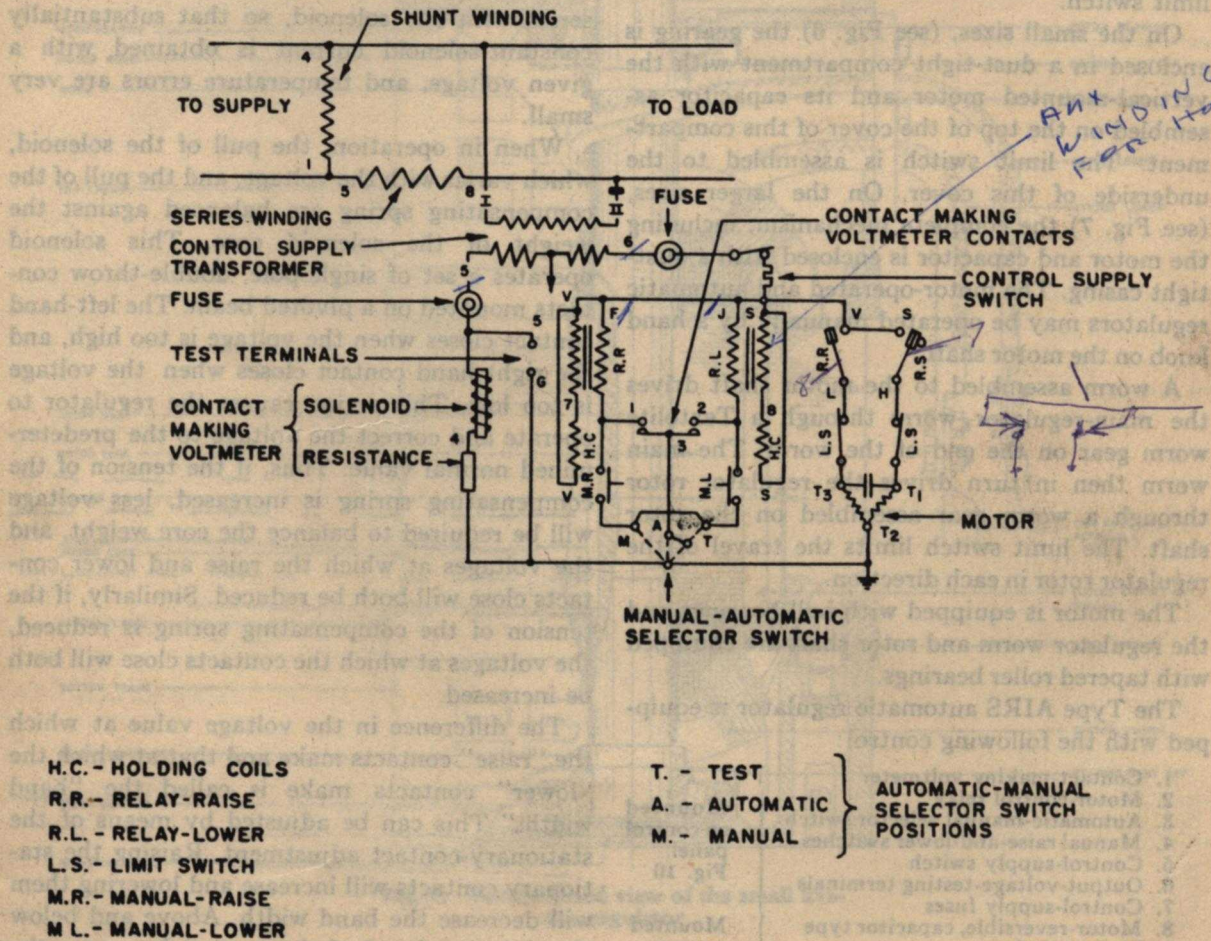

Fig. 4. Schematic diagram of Fig. 2

G 5
e o

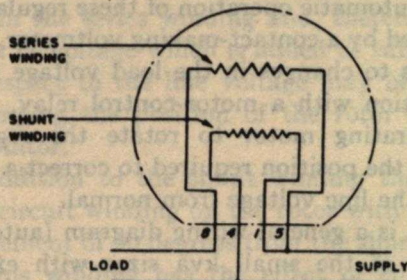

Fig. 5. Schematic diagram of hand-operated regulators

matic diagram of the hand-operated regulators in either construction.

The operating mechanism of the motor and automatic regulators consist of a double worm and worm-gear drive, a capacitor motor, and a limit switch.

On the small sizes, (see Fig. 6) the gearing is enclosed in a dust-tight compartment with the vertical-mounted motor and its capacitor assembled on the top of the cover of this compartment. The limit switch is assembled to the underside of this cover. On the larger sizes, (see Fig. 7) the complete mechanism, including the motor and capacitor is enclosed with a dust-tight casing. The motor-operated and automatic regulators may be operated manually by a hand knob on the motor shaft.

A worm assembled to the motor shaft drives the main-regulator worm through a Textolite worm gear on the end of the worm. The main worm then in turn drives the regulator rotor through a worm gear assembled on the rotor shaft. The limit switch limits the travel of the regulator rotor in each direction.

The motor is equipped with ball bearings and the regulator worm and rotor shaft are equipped with tapered roller bearings.

The Type AIRS automatic regulator is equipped with the following control:

- | | |
|--|-------------------------------------|
| 1. Contact-making voltmeter | } Mounted on control panel. Fig. 10 |
| 2. Motor-control relay | |
| 3. Automatic-manual selector switch | |
| 4. Manual raise-and-lower switches | |
| 5. Control-supply switch | |
| 6. Output-voltage-testing terminals | } Mounted on regulator cover |
| 7. Control-supply fuses | |
| 8. Motor-reversible, capacitor type | |
| 9. Limit switch | |
| 10. Control-supply transformer (on large kva sizes only) | |

1. Contact-making Voltmeter, Type TSB-20—

See Fig. 8

The Type TSB-20 contact-making voltmeter is both a measuring device and a relay; it continuously measures the regulator-output voltage and controls the operation of the driving motor on the regulator, as required, to maintain that voltage within the preset band.

The sensitive element of the Type TSB-20 contact-making voltmeter is a solenoid with an iron core suspended from a spring. It responds to current changes. To measure voltage, the solenoid current must always be proportional to the voltage.

In the Type TSB-20 contact-making voltmeter, this condition is obtained by using a ballast with a low-temperature coefficient in series with the solenoid, so that substantially constant-solenoid current is obtained with a given voltage, and temperature errors are very small.

When in operation, the pull of the solenoid, which varies with the voltage, and the pull of the compensating spring are balanced against the weight of the solenoid core. This solenoid operates a set of single-pole, double-throw contacts mounted on a pivoted beam. The left-hand contact closes when the voltage is too high, and the right-hand contact closes when the voltage is too low. This action causes the regulator to operate and correct the voltage to the predetermined normal value. Thus, if the tension of the compensating spring is increased, less voltage will be required to balance the core weight, and the voltages at which the raise and lower contacts close will both be reduced. Similarly, if the tension of the compensating spring is reduced, the voltages at which the contacts close will both be increased.

The difference in the voltage value at which the "raise" contacts make and that at which the "lower" contacts make is called the "band width." This can be adjusted by means of the stationary-contact adjustment. Raising the stationary contacts will increase and lowering them will decrease the band width. Above and below the right-hand end of the contact beam are the holding-coil assemblies. Connections are made

Induction-voltage Regulator, Type AIRS GEH-1085B

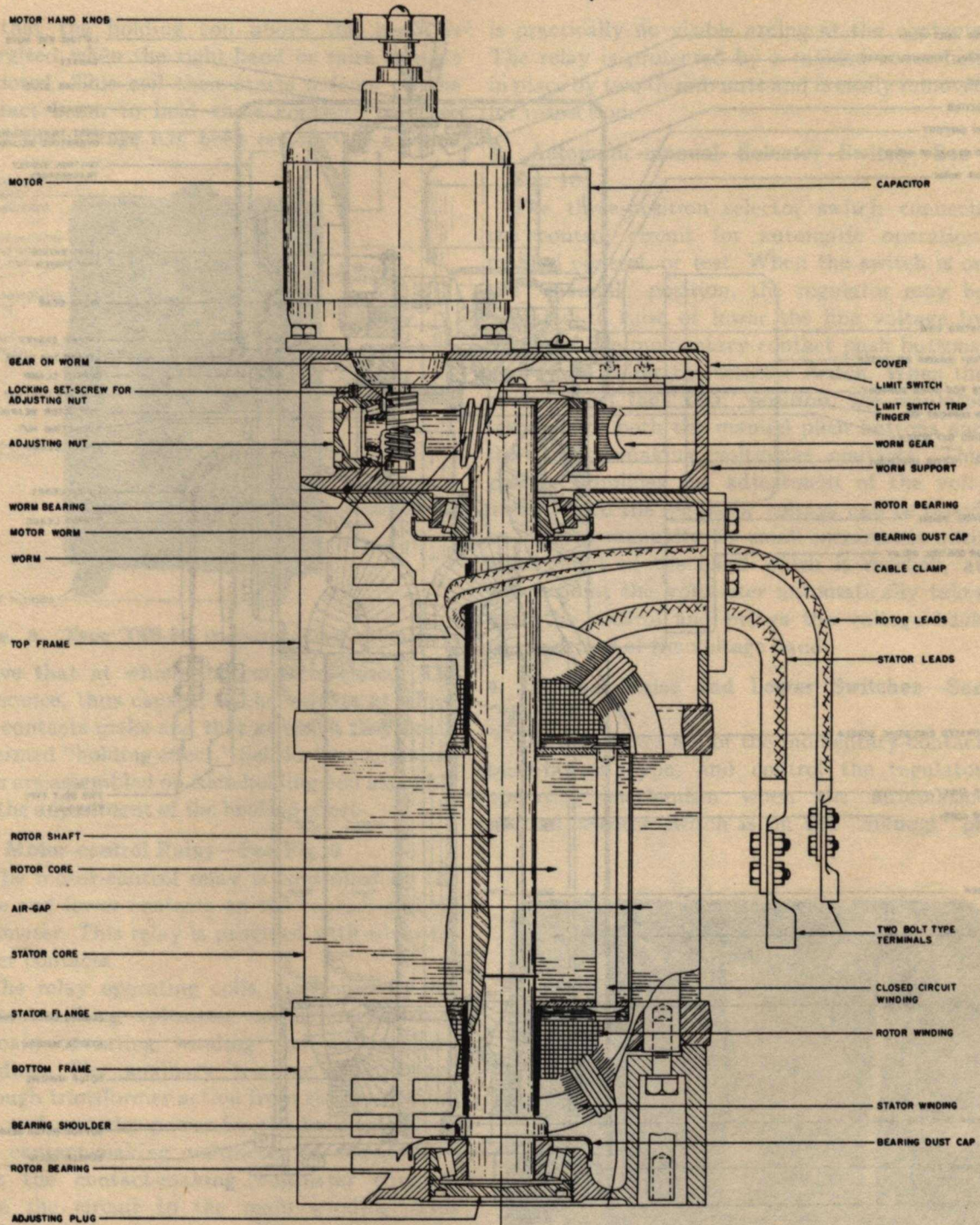

Fig. 6. Sectionalized view of the small kva-size regulator

GEH-1085B Induction-voltage Regulator, Type AIRS

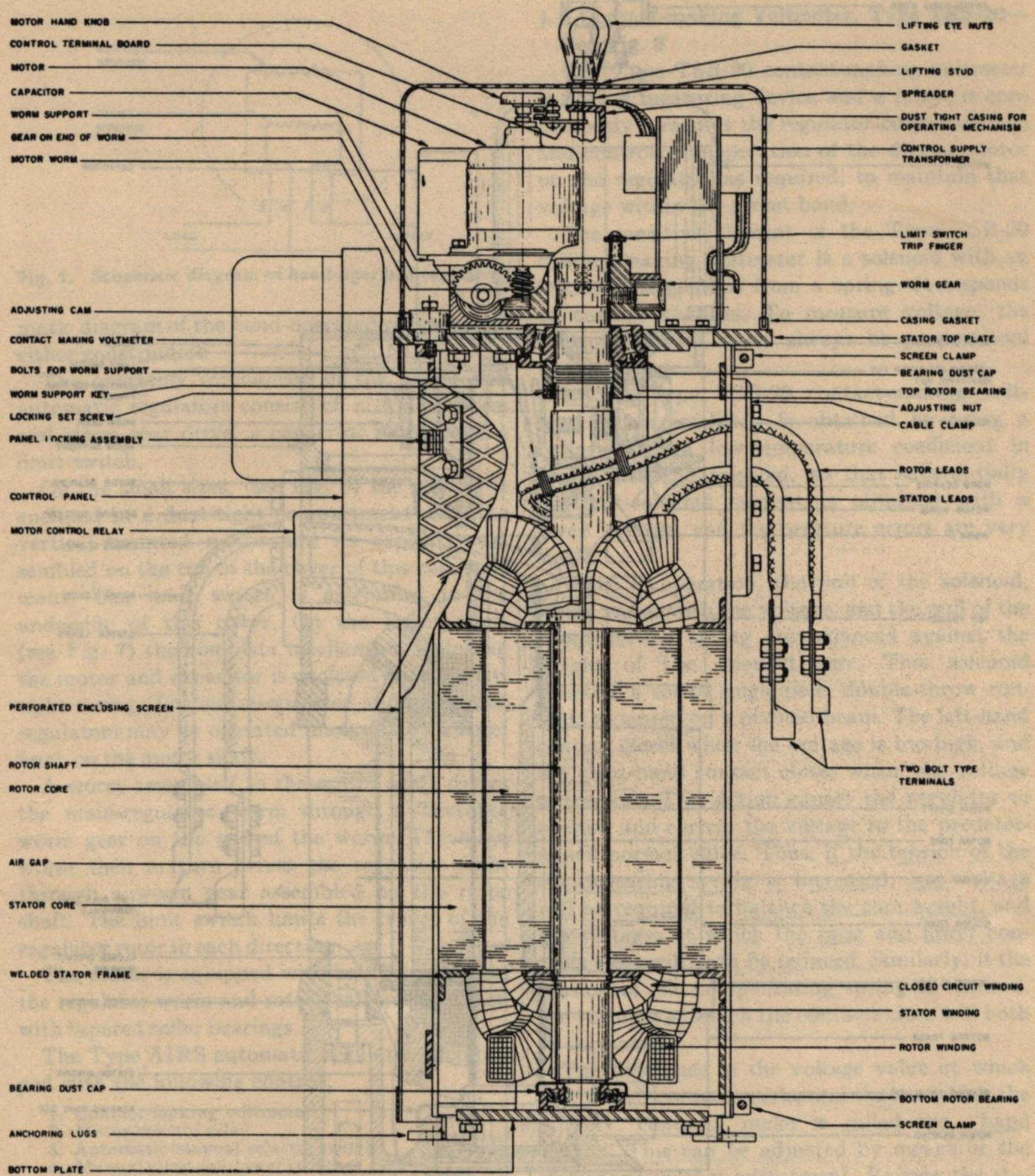

Fig. 7. Sectionalized view of the large kva-size regulator

so that the holding coil above the beam is energized when the right-hand or raise contact is closed. This coil then exerts a force on the contact beam to hold these contacts together until the voltage has been restored to a value

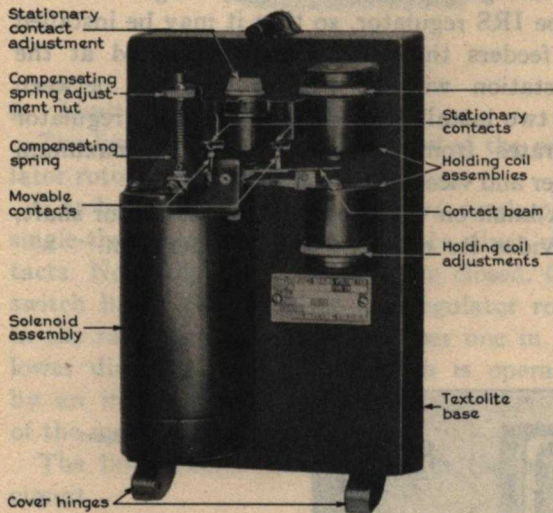

Fig. 6. Type TSB-20 contact-making voltmeter

above that at which the contacts closed. The difference, thus caused, in the voltage at which the contacts make and that at which they break is termed "holding effect." Self-locking adjusting nuts are assembled on each holding-coil assembly for the adjustment of the holding effect.

2. Motor-control Relay—See Fig. 9

The motor-control relay is controlled by the raise and lower contacts on the contact-making voltmeter. This relay is provided with silver-to-silver contacts.

The relay operating coils, controlled by the contact-making voltmeter contacts, consist of a main operating winding and an auxiliary winding. The auxiliary winding is energized through transformer action from the main winding, and provides power for the holding coils of the contact-making voltmeter at the instant that the contact-making voltmeter contacts close the circuit to the main winding. This method of energizing the holding coils, and the extremely low current required for the main relay winding, results in a contact-making voltmeter contact current so small that there

is practically no visible arcing at the contacts. The relay is protected by a molded cover held in place by two thumb nuts and is easily removed for inspection.

3. Automatic-manual Selector Switch—See Fig. 10

The three-position selector switch connects the control circuit for automatic operation, manual control, or test. When the switch is on the "manual" position, the regulator may be operated to raise or lower the line voltage by means of the momentary-contact push buttons, above and below the selector switch. When the switch is on the "test" position, the regulator responds to both the manual push buttons and the contact-making voltmeter contacts. This greatly simplifies the adjustment of the voltmeter, since the regulator voltage can be raised or lowered manually by small increments until either limit of the band width is reached, at which point the voltmeter automatically takes over the control and brings the voltage back to the center of the voltage band.

4. Manual Raise and Lower Switches—See Fig. 10

These switches are of the momentary-contact push-button type, and control the regulator operating mechanism when the automatic-manual selector switch is on the "manual" or

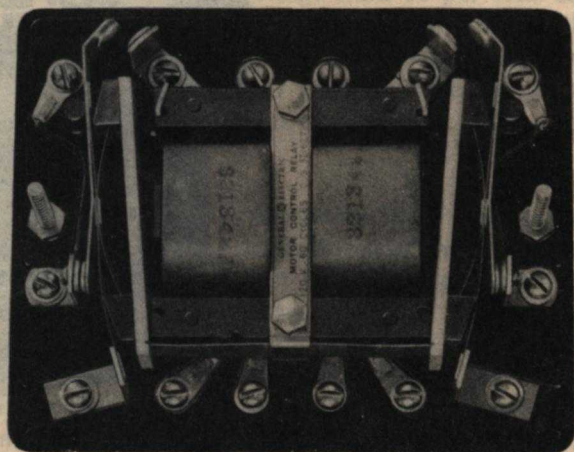

Fig. 9. Motor-control relay

5. Control-Supply Switch—See Fig. 10

This switch is of the enclosed toggle type with thermal overload protection and serves to disconnect the motor circuit from the control supply.

6. Output-voltage Testing Terminals—See Fig. 10

The two voltage-testing terminals on the front of the control panel provide means for reading the output voltage at the regulator terminals.

7. Control-Supply Fuses—See Fig. 10

The control-supply fuses located on the front of the control panel are for the protection of the control supply from a short circuit.

8. Motor, Reversible, Capacitor Type

The driving motor is of the reversible, capacitor, ball-bearing type with unusually high-starting torque for rapid acceleration. The average rate of voltage correction of the Type AIRS regulator is considerably longer than the Type IRS regulator, so that it may be installed on feeders that are already regulated at the substation without causing hunting between the two installations. The Type AIRS regulator operates from maximum raise to maximum lower and vice versa in 40 seconds.

A knob on the upper end of the motor shaft, provides for emergency hand operation.

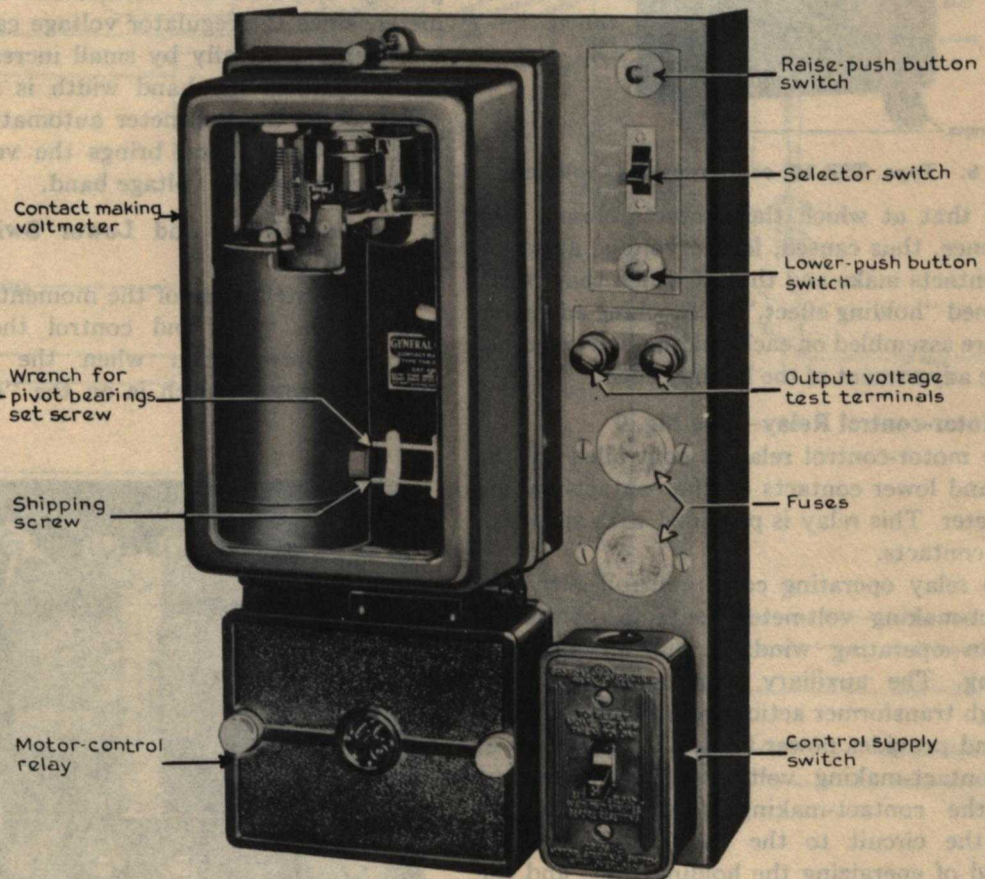

Fig. 10. Control panel



Fig. 11. Limit switch

9. Limit Switch—See Fig. 11

The limit switch limits the travel of the regulator rotor at the maximum positions.

The limit switch consists of two single-pole, single-throw switches with silver-to-silver contacts. Normally these switches are closed. One switch limits the travel of the regulator rotor in the raise direction and the other one in the lower direction. The limit switch is operated by an insulated trip finger assembled on top of the main worm gear.

The limit switch contacts are in the motor circuit.

10. Control Supply

On the small kva sizes, the control supply for the motor may be obtained from any 120-volt, 60-cycle 1.5-ampere capacity source. The control for the contact-making voltmeter should be taken from the load-side regulator terminals for load voltages 120 and 240 volts. Above 240 volts, a potential transformer with a capacity of at least 50 volt-amperes should be used to step down the voltage to 120 volts.

On the large kva sizes, a control-supply transformer is assembled on the stator cover and supplies the power for the control.

This transformer is connected to the load side of the regulator and the voltage varies with the load voltage so that the contact-making voltmeter will hold constant voltage on the feeder.

Line-drop Compensator (Optional)

Since Type AIRS regulators can generally be installed at or near the center of the load, the voltage drop to the load is of a negligible value and has no appreciable effect on the voltage regulation delivered at that point. If it is necessary to install this type of regulator a considerable distance from the load center, line-drop

compensation may be required. Regulators with line-drop compensators on the control panels may be obtained.

Shipment

Each regulator is shipped completely assembled. The crating is provided with skids to facilitate handling in transportation. When lifting the crated regulators, slings should be used under the skids on the crate.

Storage

If the regulator is not to be used immediately, it should be stored in a clean, dry place where the temperature is reasonably uniform.

Handling

The uncrated regulators should be lifted with slings attached to the eye nuts on the top. On the large regulators a spreader, equal in length to the distance between the eye nuts, should be used between the slings to prevent deforming the lifting studs.

Installation

Before installing the regulator, see that it is suitable for the circuit that it is to control. All rating data appear on the regulator nameplate. All induction-voltage regulators have a minus ten per cent and a plus ten per cent tolerance in voltage rating, that is, they are so designed that with an input voltage from 90 per cent to 110 per cent of the rated voltage, they will operate over their entire range of raise and lower without exceeding 55 C rise, if neither the kva nor the ampere rating is exceeded.

Connections

The Type AIRS regulators have the shunt and series winding leads brought out through a cable bushing on the back. These leads are provided with two-bolt terminals.

A connection diagram furnished with each regulator (number stamped on the regulator nameplate) gives in detail the connections to be made in connecting the regulator into the line.

On the smaller kva sizes, in addition to connecting the regulator to the line, it will be

necessary to connect the control panel to the control leads on the regulator and, also, separate sources of supply for the motor and the control panel should be connected as shown on the connection diagram.

Before connecting an automatic regulator into the line, open the control-supply switch on the control panel.

Install the regulator in a location that is dry, has good ventilation, and is free from dust and dirt. The support for the regulator should be flat, level, and rigid.

The use of fuses in the incoming lines to the shunt winding is not recommended because of the high potential that would be induced in the series winding, if the line connections to the shunt winding were opened while current was flowing in the series winding. In general, the feeder should be disconnected when putting the regulator in or out of service.

Grounding

Induction-voltage regulators should be permanently grounded, using a copper conductor with a cross section at least equal to the maximum-size conductor that connects the regulator to the line.

Checking Direction of Rotation

After the regulator is connected into the circuit, close the control-supply switch on the panel, set the auto-manual selector switch on the panel in the manual position. Operate the regulator in both directions with the manual raise and lower switches, checking the dial on the hand knob on the motor to see that the regulator rotates correctly.

Contact-making Voltmeter, Type TSB-20

The contact-making voltmeter has a dust-tight cover with a glass front. This cover is hinged at the bottom and held at the top by a spring latch. Remove the shipping screw (end painted red) located at the top of the solenoid core and the solenoid case. This shipping screw should be inserted in the clip on the front of the base for future use, in case the voltmeter is de-energized for any length of time or the regulator is moved.

The operation of the voltmeter should be free from sluggishness. This may be determined by observing the operation of the voltmeter-contact beam, which should move freely without jerking or binding. If the movement is sluggish, the bearings should be carefully examined and adjusted as explained under MAINTENANCE.

Alignment of Contacts—See Fig. 12

Both the stationary and movable contacts of the voltmeter are spherical in shape and should meet with a butting contact, that is, the centers of the spheres should be in alignment when the contacts meet.

The spacing of these contacts is shown in Fig. 12. The (B) spacing should always be less than (A). The amount depends upon the voltage-band width and is determined by the requirement that after contact is made and the holding effect has developed the necessary contact pressure, the contact centers will then coincide. The stationary contacts can be adjusted to obtain this condition by moving these contacts slightly to the left or right, by means of the extensions provided on the contact holders. It should be possible to make these adjustments without loosening the screws that hold these stationary contacts into the contact assembly.

Adjustment of Contact-making Voltmeter— See Fig. 13

At the factory, the contact-making voltmeter has been adjusted for a normal load-center voltage of 120 volts with the voltage-band width limits at 119 volts and 121 volts. This band-width adjustment is recommended for all average lighting-feeder applications.

In order to check these settings of the contact-making voltmeter and make such readjustments as the installation may require, an indicating voltmeter should be connected to the output-voltage testing terminals on the control panel. The indicating voltmeter will then show the voltage for which the contact-making voltmeter is adjusted.

A very convenient means for checking the various adjustments of the voltmeter is obtained by utilizing the induction regulator itself to

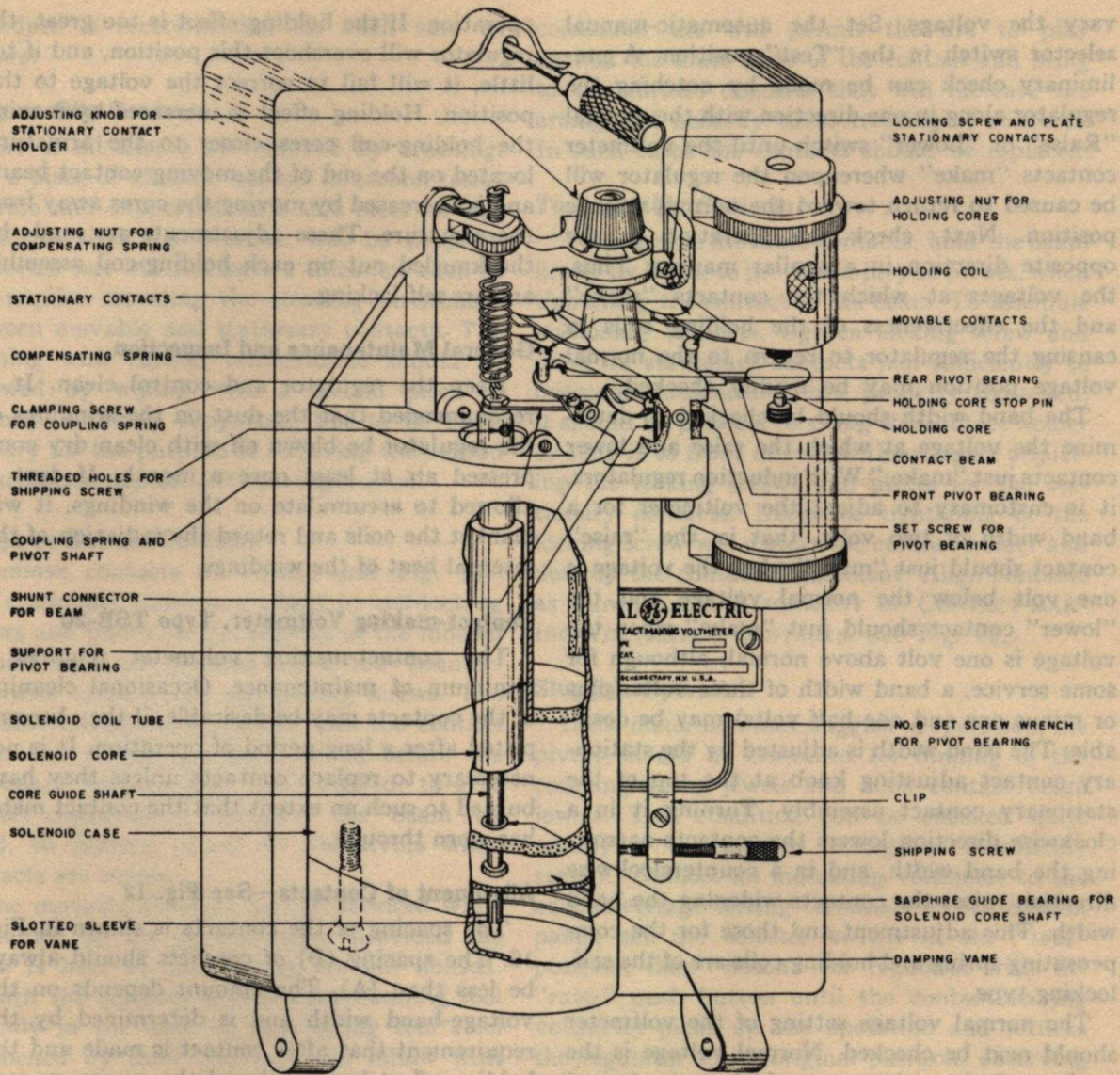

Fig. 13. Sectionalized view of Type TSB-20 contact-making voltmeter

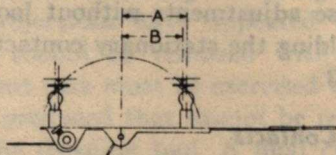

Fig. 12. Alignment of contact-making-voltmeter contacts

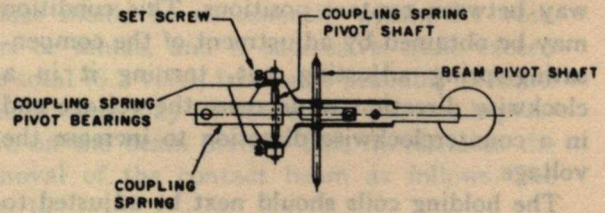

Fig. 14. Contact-making-voltmeter beam assembly

vary the voltage. Set the automatic-manual selector switch in the "Test" position. A preliminary check can be made by notching the regulator along in one direction with the manual "Raise" or "Lower" switch until the voltmeter contacts "make" whereupon the regulator will be caused to return toward the normal voltage position. Next, check the operation in the opposite direction in a similar manner. Thus, the voltages at which the contacts "make" and the effectiveness of the holding coils in causing the regulator to return to the normal voltage position may be readily checked.

The band width should be checked to determine the voltage at which the raise and lower contacts just "make." With induction regulators, it is customary to adjust the voltmeter for a band width of two volts, that is, the "raise" contact should just "make" when the voltage is one volt below the normal voltage and the "lower" contact should just "make" when the voltage is one volt above normal, although for some service, a band width of three volts (plus or minus one and one half volts) may be desirable. The band width is adjusted by the stationary contact adjusting knob at the top of the stationary contact assembly. Turning it in a clockwise direction lowers the contacts narrowing the band width, and in a counterclockwise direction raises the contacts widening the band width. This adjustment and those for the compensating spring and holding coils are of the self-locking type.

The normal voltage setting of the voltmeter should next be checked. Normal voltage is the median of the voltage at which it is desired that the raise and lower contacts shall respectively close. At this voltage, the contact beam should balance in a horizontal position, halfway between contact positions. This condition may be obtained by adjustment of the compensating-spring adjusting nut, turning it in a clockwise direction to decrease the voltage and in a counterclockwise direction to increase the voltage.

The holding coils should next be adjusted to give sufficient holding effect to return the regulator to the normal voltage position after each

operation. If the holding effect is too great, the regulator will overshoot this position, and if too little, it will fail to correct the voltage to this position. Holding effect is increased by moving the holding-coil cores closer to the armature, located on the end of the moving contact beam, and is decreased by moving the cores away from the armature. These adjustments are made by the knurled nut on each holding-coil assembly and are self-locking.

General Maintenance and Inspection

Keep the regulator and control clean. It is recommended that the dust on the windings of the regulator be blown off with clean dry compressed air at least once a month. If dust is allowed to accumulate on the windings, it will blanket the coils and retard the radiation of the internal heat of the windings.

Contact-making Voltmeter, Type TSB-20

The contact-making voltmeter requires a minimum of maintenance. Occasional cleaning of the contacts may be desirable, if they become pitted after a long period of operation. It is not necessary to replace contacts unless they have burned to such an extent that the contact metal has worn through.

Alignment of Contacts—See Fig. 12

The spacing of the contacts is shown in Fig. 12. The spacing (B) of contacts should always be less than (A). The amount depends on the voltage-band width and is determined by the requirement that after contact is made and the holding effect has developed the necessary contact pressure the contact centers will then coincide. The stationary contacts can be adjusted to obtain this condition by moving these contacts by means of the extensions provided on the contact holders. It should be possible to make these adjustments without loosening the screws holding the stationary contacts in place: See Fig. 13.

Cleaning Contacts

The surface of the contacts may be dirty or oily, or they may be burned rough, and a separate

procedure is recommended for each case as follows:

Dirty or Oily Contacts

Dirt or oil should be removed by brushing. Use a piece of chamois soaked in carbon tetrachloride and supported on a thin piece of flat metal, so that the chamois will be properly supported but will not have a thickness such as will require crowding the cleaning instrument between movable and stationary contacts. The cleaning with carbon tetrachloride should be followed by wiping with a second piece of chamois, similarly supported, but to be clean and dry for the purpose of removing the carbon tetrachloride deposit left by evaporation.

Rough or Burned Contacts

Remove contacts as follows (see Fig. 13): The stationary contacts are held by self-locking screws and plates in the pockets of the molded support and are released by a few counter-clockwise turns of the self-locking screws. The movable contacts are screwed into the contact beam and should not be removed before the stationary contacts are first removed, to give greater accessibility. Support the beam by hand, to prevent injury to the pivots when contacts are turned.

The movable contacts can be serviced while assembled on the contact beam provided the beam is held so that pivots are not abused. Smooth the surfaces with a relay-cleaning tool (usually in the form of thin spring tool steel roughened by sand blasting) and follow with the dry chamois cleaner as directed above. Stationary contacts should be smoothed similarly but a spacer should be placed between the back of the contact supporting spring and the contact holder, so that a solid support will be given the contact, to prevent distorting the spring.

If small projections have appeared on the surface, they should be removed with a fine ignition file, but care must be exercised that no scratches are produced that cannot be removed entirely by the cleaning tool. A final cleaning with a chamois should be made. If perforation of the movable-contact metal has occurred,

continued use will permit the arc to play against the brass body of the contact and bring to the surface deposits that will increase the arcing and possibly cause freezing of contacts. In such cases the contacts should be replaced.

To Assemble Contacts

To assemble movable contacts, hold the beam firmly by hand, to prevent injury to pivots, when tightening the contact in the beam. To assemble stationary contacts, tighten locking screw and plate for stationary contacts just sufficiently to overcome looseness. When properly tightened, it should be possible to swing the contact holder or slide it to front or rear without again adjusting the locking screws and plates for the stationary contacts. Excessive tightening of the locking screw will distort the contact holder and destroy the contact adjustment. Align contacts as shown under ALIGNMENT OF CONTACT-MAKING VOLTMETER CONTACTS. See Fig. 12.

Sluggish Operation

If the meter becomes sluggish in operation, the pivots should be examined for binding of the coupling-spring jewels and main contact beam jewels. This condition can be checked quite readily if the applied voltage is reasonably steady. Connect an indicating voltmeter to the output-voltage testing terminals on the control panel, set the selector switch in the "test" position, then "notch" the regulator with the "raise" push button until the contact-making voltmeter picks up the operation and returns the regulator to its original position, observing very carefully the voltage on the indicating voltmeter at which the contact-making voltmeter picks up the operation each time. Repeat, using the "lower" push button. The observed values should be consistently within 0.1 volt, plus or minus, and if successive trials exceed the total (0.2 volt), friction is probably present. The binding may be caused by too much pressure on the beam pivots. This necessitates the removal of the contact beam as follows. See Fig. 13.

First, insert the shipping screw in the threaded holes in the top of the solenoid core and solenoid

case, making sure that screw threads engage in the solenoid core without disturbing the alignment of the front pivot bearing, second, disconnect the shunt connector for the beam, where it is clamped to the terminal post in the meter base, by loosening the screw to permit pulling the shunt out from under the clamp; third, remove the clamping screw for the coupling spring in the top of the core stem; fourth, loosen the setscrew for the front pivot bearing and push the front pivot bearing to the front of the casting as far as it will go; fifth, disengage the beam-pivot shaft from the front-pivot bearing and remove the beam.

To check for friction in the coupling-spring pivot bearings; first, hold the contact-beam shaft vertical, as shown in Fig. 14; second, tip very slightly from vertical so that the coupling member will start swinging. If the coupling-member movement is hesitant, the pivot bearings may be too tight or the coupling-shaft pivot points may be defective. Third, to correct tightness, loosen the upper pivot bearing, as shown in Fig. 14, by means of the setscrew, set it against the pivot shaft and retighten setscrew, and again check for friction by "swing" of the coupling member. Repeated trials may be necessary to obtain the free swing required, but do not allow end play between shaft and bearings (detected by using the coupling spring as a lever and applying light force against the bearings). No noticeable shift of pivot points should be evident.

If a free "swing" of the coupling member cannot be obtained in this manner, the coupling-shaft pivot points may be defective. Remove the coupling spring and pivot shaft by first loosening the setscrew and moving the upper bearing out far enough to disengage the shaft. Check the pivot points under a 3X magnifying glass. The points should be needle-like and free from cracks and distortion.

NOTE: The position of the coupling spring and its shaft, with respect to the contact beam and its shaft, is located by gage at the factory, and perfect realignment will be assured by disturbing only the one pivot bearing indicated. This is true even if a renewal part is used. Under

no circumstances should the bracket sides of the contact beam be bent to make adjustment of the coupling pivot bearings.

The binding may be caused by too much pressure on the beam-pivot shaft. This should be checked as follows.

(Front Pivot-bearing Assembly)

Check the pivot points as explained above for the coupling-spring pivots.

Check front pivot-bearing assembly in accordance with Fig. 15A and then assemble in bracket with beam, in accordance with Fig. 15B, using a feeler gage to check for proper clearance.

Assembly of Contact Beam

Follow the reverse order of procedure outlined under the removal of contact beam. Check the position of the front pivot bearing and its support before and after assembly, to insure alignment and proper end thrust. Do not allow shunt connector for beam to touch solenoid case as this will ground the contact beam.

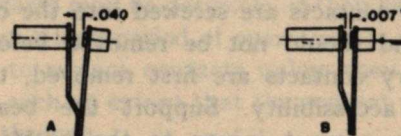
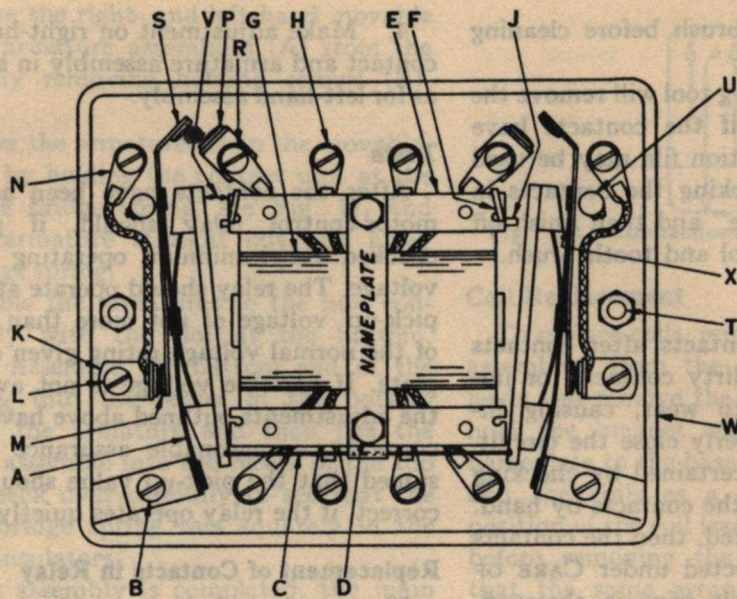

Fig. 15. Contact-making-voltmeter front-pivot bearing

Motor-control Relay—See Fig. 16

The motor-control relay is provided with two sets of silver-to-silver contacts. One set, which is normally open, is used to control the motor circuit and the other set, normally closed, is not used on the Type AIRS control circuit. It is not necessary to replace the contacts or clean them if they show only discoloration, due to the normal effect of arcing. The wiping action in making contact, will keep the actual contact surface clean and insure a good electrical contact. The contacts should be replaced when the contact-face material is burned away, and there is no longer any wiping action. The motor-control relay coils are designed to operate satisfactorily at 80 per cent of their normal operating voltage.



- | | |
|--|---|
| <p>A. MOVABLE CONTACT AND ARMATURE ASSEMBLY.</p> <p>B. HOLDING SCREW.</p> <p>C. ARMATURE SPACER.</p> <p>D. HEX. HOLDING SCREW.</p> <p>E. MAGNET CORE.</p> <p>F. POLE SHADER.</p> <p>G. OPERATING COIL.</p> <p>H. OPERATING COIL TERMINALS.</p> <p>J. MECHANICAL ARMATURE INTERLOCK.</p> <p>K. STATIONARY CONTACT-DYNAMIC BRAKING CIRCUIT.</p> <p>L. HOLDING SCREW.</p> | <p>M. MOVABLE CONTACT-DYNAMIC-BRAKING CIRCUIT.</p> <p>N. TERMINAL FOR DYNAMIC BRAKING CONTACT.</p> <p>P. STATIONARY CONTACT-MOTOR CIRCUIT.</p> <p>R. HOLDING SCREW.</p> <p>S. MOVABLE CONTACT-MOTOR CIRCUIT.</p> <p>T. STUD FOR MOUNTING RELAY AND HOLDING COVER.</p> <p>U. MOLDED STOP PINS.</p> <p>V. ARMATURE GAP AT TOP OF MAGNET CORE.</p> <p>W. MOLDED BASE.</p> <p>X. GAP.</p> |
|--|---|

Fig. 16. Motor-control relay

Servicing of Relay Contacts

The contacts will become discolored from service. This is a natural process where silver-to-silver contacts are used. This discoloration will do no harm, providing arcing does not continue after contact is made. Arcing in the presence of noxious gases or salt air will cause deposits to form on contact surfaces, which will eventually interfere with proper circuit closing.

Care of Contacts

To clean the contacts, use a relay-cleaning tool. This is usually a piece of spring-tool steel that has been sand-blasted or etched to form a very fine rough surface. After cleaning with tool, brush contact with a clean, dry tooth brush. If a gummy deposit is present on the contacts, first brush with a clean tooth brush, moistened with carbon tetrachloride, let dry, then brush

with a clean, dry tooth brush before cleaning with the cleaning tool.

In most cases the cleaning tool will remove the roughened surfaces, but if the contacts have become pitted, a fine ignition file may be used to clean up the pits, stroking the contacts in the direction of the "Wipe" and then finish off as above with cleaning tool and tooth brush.

Adjustment of Contacts

Continued arcing of contacts after contacts are closed may indicate dirty contacts, or improper adjustment due to wear, causing insufficient pressure to properly close the circuit.

This may be readily ascertained by checking the "wipe," when closing the contacts by hand. If a good "wipe" is indicated, then the contacts should be cleaned as directed under CARE OF CONTACTS. If no noticeable wipe is observed, the contacts should be readjusted as follows:

(Pin Gage in Clip on Back of Panel.)

1. Insert a pin gage ($\frac{1}{8}$ inch diameter) in armature gap (V) on left-hand side of core. Exert pressure directly against the center of the armature, not against contact assembly, to hold it firmly against the gage. Move the stationary contact (K) in its groove in the base until it just touches the movable contact (M), then retighten the holding screw (L) firmly.

2. Release the armature and allow contacts (K) and (M) to fully engage. In this position of the movable contact and armature assembly, the flat-steel support that the movable contacts are welded to should just clear (must not exceed $\frac{1}{32}$ inch) the molded stop (U) in the base. If this does not clear the molded stop (U) and the contact adjustment checks, it will be necessary to loosen the holding screw (B), very slightly, and then drive the bracket of the contact assembly minutely toward the core to obtain the minimum gap required.

3. Insert a pin gage ($\frac{1}{16}$ inch diameter) in the armature gap and exert pressure against armature, as in paragraph (1) to hold gage in place. Move the stationary motor-circuit contact (P), in its slot in the base, until it just touches the motor-circuit movable contact (S). Tighten holding screw (R) firmly.

4. Make adjustment on right-hand movable contact and armature assembly in same manner as for left-hand assembly.

Tests

After the contacts have been adjusted, the motor-control relay should, if possible, be checked for minimum operating or pick-up voltage. The relay should operate at a minimum pick-up voltage of not more than 75 per cent of the normal voltage rating given on its nameplate. If variable voltage is not available, and the adjustments outlined above have been made correctly, a reasonable assurance may be assumed that the pick-up value should be nearly correct, if the relay operates quietly.

Replacement of Contacts in Relay

The wearing of the movable and stationary contacts should be uniform and in most cases, both the movable and stationary contacts should require replacement at the same time.

The movable-contact assemblies consist of three flat springs and silver, steel-backed contacts welded together. Fig. 17 shows the contact assembly and the method of assembling the movable contact assembly to the armature.

Before starting to assemble the contacts, the surfaces of the armature and magnet core should be thoroughly cleaned of all foreign matter

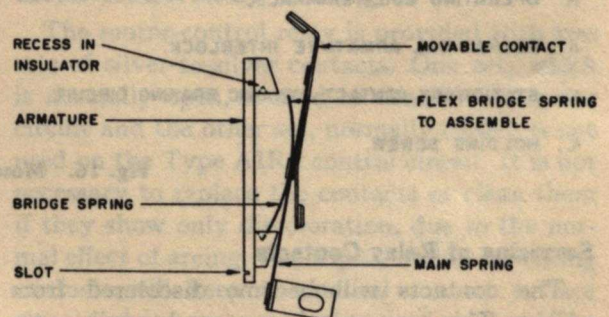

Fig. 17. Assembly of moving contact to armature on motor-control relay

This may be accomplished by using a clean tooth brush moistened in carbon tetrachloride, and when dry, brush again with a clean, dry tooth brush.

1. Remove the right- and left-hand movable contact and armature assemblies (A) from the relay base by removing holding screws (B). See Fig. 16.

2. Remove the armatures from the movable-contact unit by holding the contact unit at the center of the bridge spring, see Fig. 17, and pulling the armature straight out and away from the bridge spring.

3. Assemble the armatures to the new contact assembly with the slot at the bottom, see Fig. 16. Assemble the bottom end of the bridge spring into the recess in the bottom insulator on the armature and then flex the top end and assemble into the recess in the top insulator. Check over carefully to see that the end of the bridge spring sets squarely in the recess in the insulators.

When this assembly is completed, the main spring of the contact assembly should just touch or just clear the bottom insulator and at the top, it should clear the top insulator by at least $\frac{1}{8}$ inch and not more than $\frac{1}{2}$ inch.

If this clearance is not obtained, it will be necessary to remove enough stock from the high edge of the top insulator to obtain the minimum clearance. See Fig. 16.

4. Assemble the movable contact and armature assemblies (A) into the grooves in the relay base with the holding screws (B) loose for adjustment. Insert armature spacer in slot in armatures. Hold the top of armature tight against the magnet core pole face by applying pressure against the center of the armature, and not against the contact assembly. Make sure that armature spacer is seated squarely in the bottom of the slot, and the front edge of the armature is approximately parallel with the front surface of the core, determined by the matching of the motor contacts, then tighten firmly holding screw (B). Release pressure from armature and check to make sure that armature spacer is exerting pressure against armature and that there is a very small gap between bottom end of armature and bottom pole face of core. See Fig. 16.

Adjust contacts as described under ADJUSTMENT OF CONTACTS.

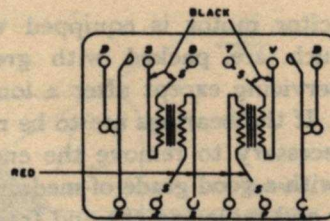

Fig. 18. Connections of motor-control relay

Coil Replacement

To replace coils, remove armature and contact assemblies from the base, disconnect the coil leads and remove the two hex-head screws that hold the magnet core, armature spacer, and nameplate to the base. Remove the magnet core and the coils as a unit. Carefully note the position of the coil leads with respect to the core, before removing the coils from the core, so that the same arrangement of leads may be followed in assembling the new coils to the core. Place the new coils on the legs of the core and reassemble the magnet, coils, armature spacer, and nameplate to the relay base. In assembling this unit to the base, make sure that the coil leads do not interfere with the full operation of the armature interlock. Connect the coil leads to the terminals in the base in accordance with Fig. 18. Identify leads by their color. Reassemble armature and movable contact assemblies. Adjust contacts as described under REPLACEMENT OF CONTACTS and ADJUSTMENT OF CONTACTS.

Miscellaneous

The automatic-manual selector switch, the manual raise and lower push-button switches, and the output-voltage test terminals should not require any servicing.

The control-supply switch is a single-pole, toggle-type switch with silver-to-silver contacts and an overload-heater-type trip. If the switch opens, due to overload, it is necessary to wait two minutes before reclosing to allow heater unit to cool. No maintenance should be necessary.

The control-supply fuses used between the control supply and the automatic controls are standard 15-ampere, Edison screw-base type.

The capacitor motor is equipped with ball bearings which are packed with grease and require no servicing except after a long period of operation. If the bearings are to be repacked, it will be necessary to remove the end frames and repack with a good grade of medium grease. In removing and replacing the end frames, care should be used to see that the preload adjustment is not disturbed.

The capacitor and limit switch should require no servicing.

Inspection (Small Kva Sizes)

To inspect the operating mechanism on the small kva sizes, set the regulator in the neutral, remove the four small screws in the corners of the cover and then lift the cover, with the motor and capacitor in place, off the worm support. The limit switch and control leads are assembled to the underside of this cover. The gearing may now be inspected.

For further inspection, disassemble the regulators as follows.

Motor and Capacitor

The motor is of the ball-bearing type, and the bearings are packed in grease when assembled. No servicing should be required on either the motor or its capacitor.

The bottom frame of the motor is rabbeted to fit into a machined hole in the cover. This hole is slightly larger than the fit on the motor end frame, to allow for adjusting the backlash between the motor worm and the Textolite gear. In reassembling the motor, adjust the backlash between the worm and worm gear to the minimum. This can be accomplished by slightly turning the hand knob on the top of the motor in each direction and moving the motor toward the front of the regulator until only a small amount of backlash remains. Make sure that when the motor is finally bolted down the worm does not bind on the gear and, therefore, impede the free operation of the motor rotor. The motor is designed to operate the regulator at 80 per cent of normal rated voltage.

Remove the four bolts holding the worm support to the top frame. Draw support toward

back of the regulator to disengage worm from worm gear and then lift it off the aligning key in the top frame.

Remove the worm gear, as shown in Fig. 19.

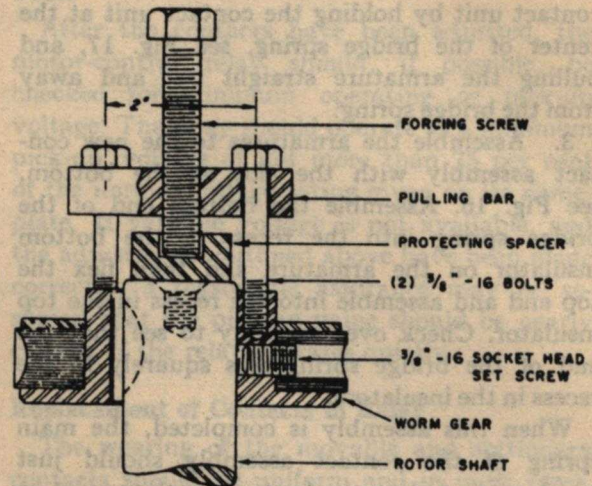

Fig. 19. Method used in removing worm gear, typical of small kva-size regulators

To remove the worm gear from the rotor shaft, loosen setscrew in side of hub.

Use the two $\frac{3}{8}$ -inch-16 tapped holes in the top of the hub to bolt a heavy steel bar with a threaded hole in center for forcing screw, Fig. 19. Space the bar from the top of the hub to allow the placing of a steel disk on top of the rotor shaft, for forcing screw to work on, so as not to damage center countersink and threads in rotor shaft. By tightening the forcing screw in the center of the bar, the worm gear will be drawn from the rotor shaft. Remove the worm gear key from the rotor shaft.

Remove the cable clamp on the back of the regulator.

Remove the two eye-nuts and the two corner bolts and then lift the top frame off the stator.

The rotor may now be removed and complete inspection made.

Below the top bearing and above the bottom bearing on the rotor shaft are assembled dust caps to keep the bearings clean.

To keep the air gap in alignment, a fit is machined in the top and bottom frame and on the top and bottom flanges of the stator core.

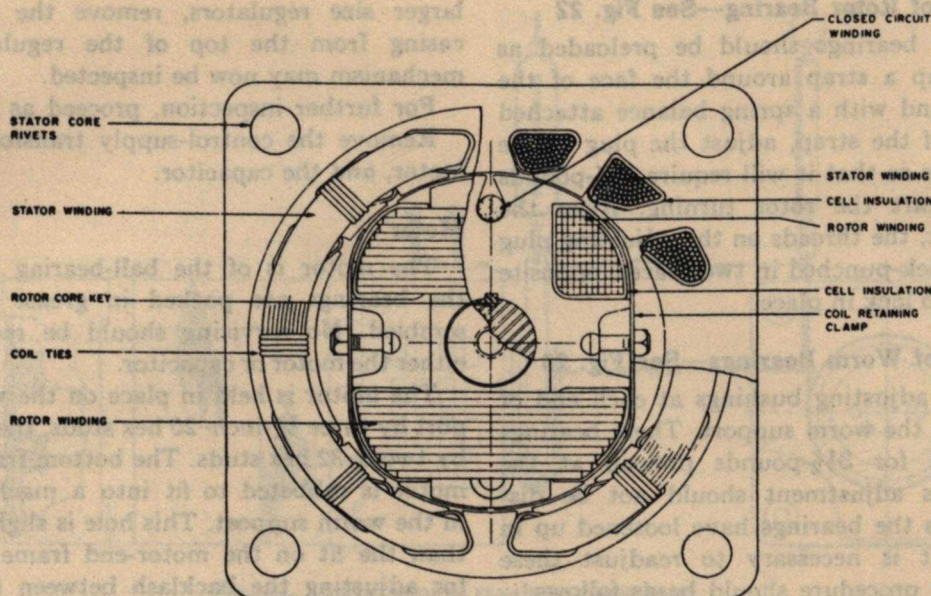

Fig. 20. Location of windings, typical of small kva-size regulators

The bottom frame may be removed by removing the four bolts in the corners.

The location of the windings is shown in Fig. 20.

Reassembly of Regulator (Small kva sizes)

To reassemble regulator, assemble the bottom frame to the stator core, making sure that the fits on the frame and core line up correctly.

The bottom bearing cup in the bottom frame is adjustable for properly preloading the rotor bearings. This adjustment is made by a threaded plug in the center of the bottom frame. This adjustment should not be disturbed unless it is necessary to readjust the load on the bearing. This adjustment is covered under ADJUSTMENT OF ROTOR BEARINGS.

Assemble the rotor into the stator.

Assemble the top frame to the stator core, making sure that the fits line up correctly.

Assemble the worm gear on the rotor shaft to its approximate location. See Fig. 21.

Heat the worm gear in an oven, to approximately 100 C. Start the worm gear on the rotor shaft by lightly tapping with a rawhide mallet on the top face of hub of gear only. Use a forcing fixture, Fig. 21, assembled in the 1/2-inch-13 tapped hole in end of rotor shaft and force gear on shaft to approximate location. To locate correctly, set worm support on top frame and check mesh of worm with gear by coating threads of worm with Prussian blue. The worm gear must mesh accurately for the proper operation of the regulator.

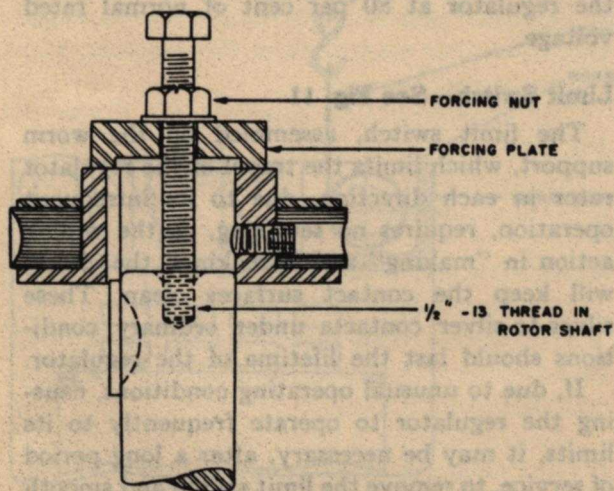

Fig. 21. Method used in assembling worm gear, typical of small kva-size regulators

Adjustment of Rotor Bearing—See Fig. 22

The rotor bearings should be preloaded as follows: Wrap a strap around the face of the worm gear and with a spring balance attached to the end of the strap, adjust the plug in the bottom frame so that it will require $3\frac{3}{4}$ -pounds torque to start the rotor turning. After the preload is set, the threads on the adjusting plug should be prick-punched in two places, opposite each other, to lock in place.

Adjustment of Worm Bearings—See Fig. 23

There are adjusting bushings at each end of the worm on the worm support. These bearings are adjusted for $3\frac{1}{2}$ -pounds preload at the factory. This adjustment should not be disturbed unless the bearings have loosened up in service. If it is necessary to readjust these bearings, the procedure should be as follows.

Wrap a strap around the worm threads and with a spring balance attached to the end of the strap take up on the adjusting collars until it requires $3\frac{1}{2}$ -pounds torque to start the worm turning. Tap each end of the worm, to seat the bearings, and then recheck the torque. After the adjustment is completed, tighten up the setscrews in the side of the casting, to lock the adjusting collars in place.

Reassemble the worm support to the top frame, making sure that the worm meshes on a center line with the worm gear by adjusting the location of the worm gear on the rotor shaft. Replace dowels in worm support and bolt into place.

Assemble cover, with motor, capacitor and limit switch to worm support. Adjust the mesh between the worm on the motor shaft and the gear on the worm to the minimum backlash, and then bolt into place.

Connect a source of 120 volts to leads "T2" and "H" and then to "T2" and "L" and operate the regulator to the limits to make sure that the limit switch operates properly, so as to stop the motor at the maximum raise and maximum lower positions.

Inspection (Large kva sizes)

To inspect the operating mechanism on the

larger size regulators, remove the dust-tight casing from the top of the regulator. The mechanism may now be inspected.

For further inspection, proceed as follows:

Remove the control-supply transformer, the motor, and the capacitor.

Motor

The motor is of the ball-bearing type, and the bearings are packed in grease when assembled. No servicing should be required on either the motor or capacitor.

The motor is held in place on the worm support by three $\frac{1}{4}$ -inch-20 hex studs, the capacitor by two 8-32 hex studs. The bottom frame of the motor is rabbeted to fit into a machined hole in the worm support. This hole is slightly larger than the fit on the motor-end frame, to allow for adjusting the backlash between the motor worm and the Textolite gear. In reassembling the motor, adjust the backlash between the worm and worm gear to the minimum. This can be easily accomplished by turning the hand knob on the top of the motor slightly in each direction and moving the motor toward the front of the regulator until only a small amount of backlash remains. Make sure that when the motor is finally bolted down with the hex studs that the worm does not bind on the gear and, therefore, impede the free operation of the motor rotor. The motor is designed to operate the regulator at 80 per cent of normal rated voltage.

Limit Switch—See Fig. 11

The limit switch, assembled on the worm support, which limits the travel of the regulator rotor in each direction, due to its infrequent operation, requires no servicing, as the wiping action in "making" and "breaking" the circuit will keep the contact surfaces clean. These silver-to-silver contacts under ordinary conditions should last the lifetime of the regulator.

If, due to unusual operating conditions, causing the regulator to operate frequently to its limits, it may be necessary, after a long period of service, to remove the limit switch and smooth up the contacts.

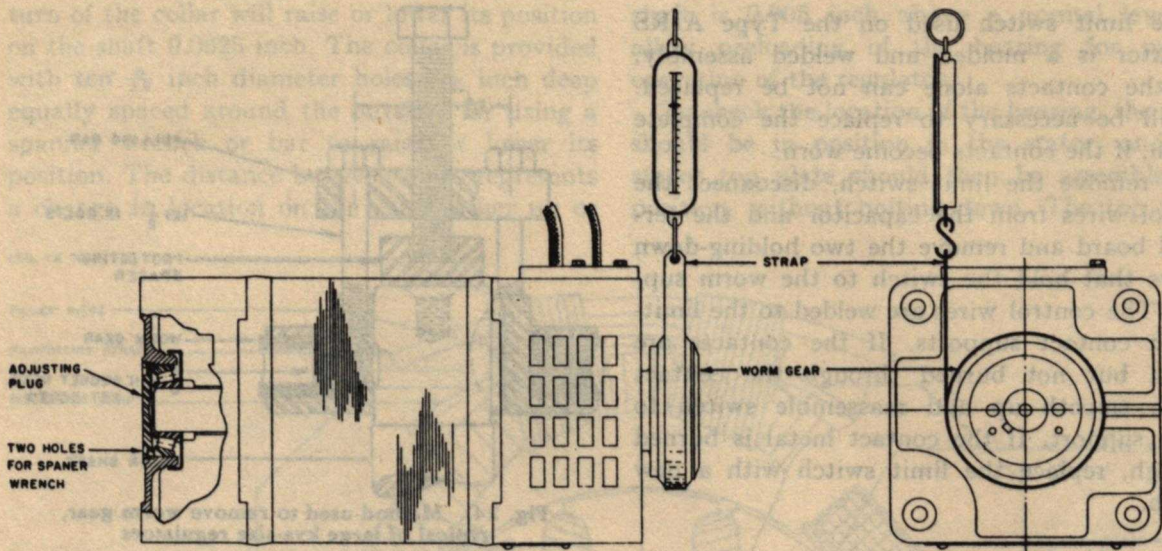

Fig. 22. Adjustment of regulator rotor bearings, typical of small kva-size regulators

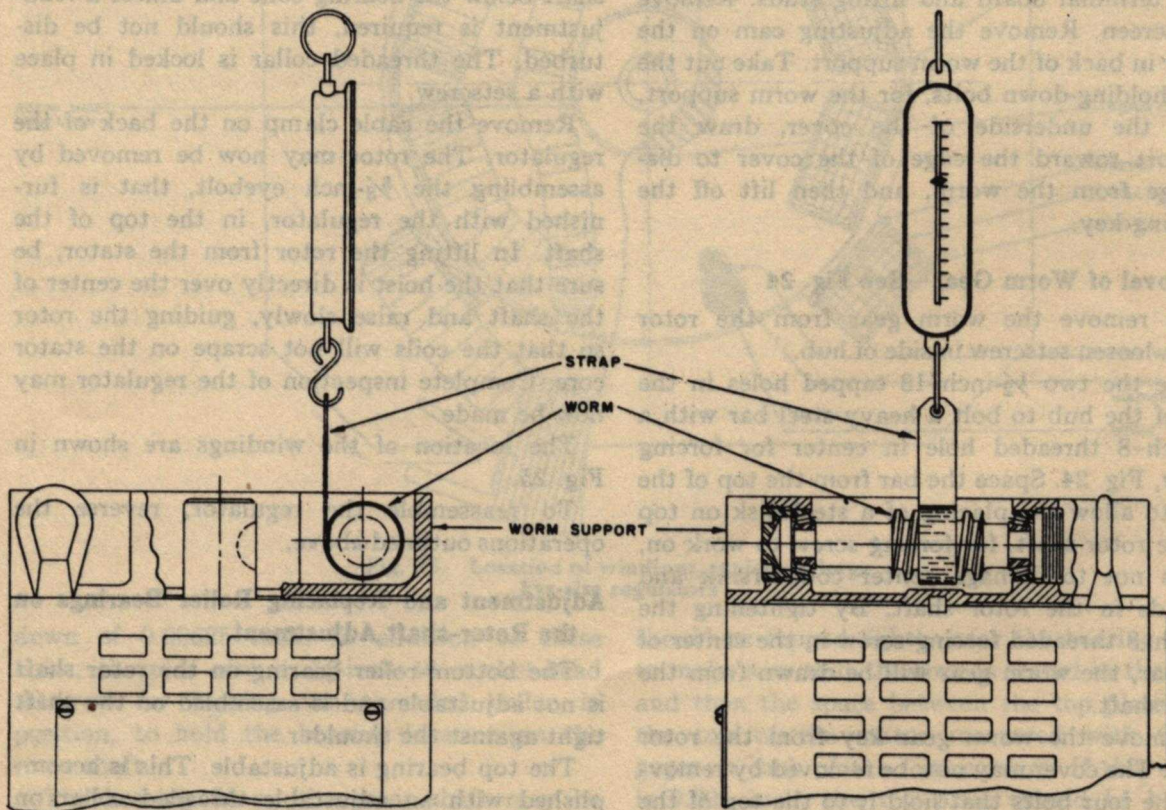

Fig. 23. Method used to preload worm bearings, typical of small kva-size regulators

The limit switch used on the Type AIRS regulator is a molded and welded assembly, and the contacts alone can not be replaced. It will be necessary to replace the complete switch, if the contacts become worn.

To remove the limit switch, disconnect the control wires from the capacitor and the terminal board and remove the two holding-down screws that hold the switch to the worm support. The control wires are welded to the limit-switch contact supports. If the contacts are rough, but not burned through the contact metal, smooth up and reassemble switch to worm support. If the contact metal is burned through, replace the limit switch with a new switch.

Disassembly

Disconnect the control wiring from the terminal board and remove the angle-iron spreader with terminal board and lifting studs. Remove the screen. Remove the adjusting cam on the cover in back of the worm support. Take out the four holding-down bolts, for the worm support, from the underside of the cover, draw the support toward the edge of the cover to disengage from the worm, and then lift off the aligning key.

Removal of Worm Gear—See Fig. 24

To remove the worm gear from the rotor shaft, loosen setscrew in side of hub.

Use the two $\frac{1}{2}$ -inch-13 tapped holes in the top of the hub to bolt a heavy-steel bar with a 1 inch-8 threaded hole in center for forcing screw, Fig. 24. Space the bar from the top of the rotor shaft, for forcing screw to work on, so as not to damage center countersink and threads in the rotor shaft. By tightening the 1 inch-8 threaded forcing screw in the center of the bar, the worm gear will be drawn from the rotor shaft.

Remove the worm gear key from the rotor shaft. The cover may now be removed by removing the four bolts that hold it to the top of the stator frame. Care should be taken to protect the bearing cup that will remain in the cover.

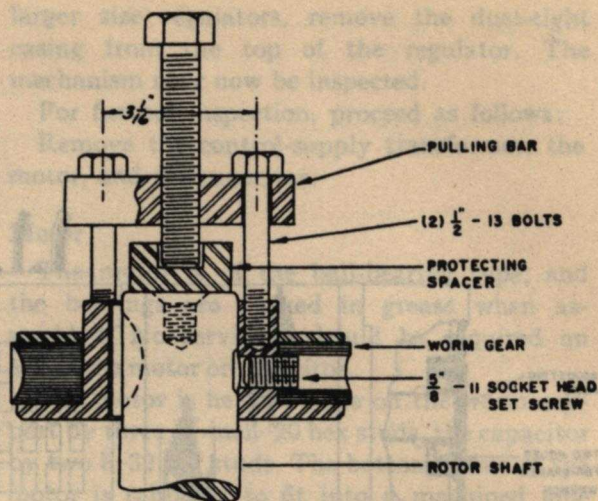

Fig. 24. Method used to remove worm gear, typical of large kva-size regulators

The top roller bearing on the rotor shaft is adjustable by means of a threaded collar on the shaft below the bearing cone and unless a readjustment is required, this should not be disturbed. The threaded collar is locked in place with a setscrew.

Remove the cable clamp on the back of the regulator. The rotor may now be removed by assembling the $\frac{5}{8}$ -inch eyebolt, that is furnished with the regulator, in the top of the shaft. In lifting the rotor from the stator, be sure that the hoist is directly over the center of the shaft and raise slowly, guiding the rotor so that the coils will not scrape on the stator core. Complete inspection of the regulator may now be made.

The location of the windings are shown in Fig. 25.

To reassemble the regulator, reverse the operations outlined above.

Adjustment and Replacing Roller Bearings on the Rotor-shaft Adjustment

The bottom-roller bearing on the rotor shaft is not adjustable and is assembled on the shaft tight against the shoulder.

The top bearing is adjustable. This is accomplished with an adjustable threaded collar on the shaft below the bearing. The collar is threaded sixteen threads per inch, and one complete

turn of the collar will raise or lower its position on the shaft 0.0625 inch. The collar is provided with ten $\frac{5}{16}$ inch diameter holes, $\frac{5}{16}$ inch deep equally spaced around the outside, for using a spanner wrench or bar to raise or lower its position. The distance between holes represents a change in location on the shaft either up or

shaft is 0.005 inch above a normal level to allow preloading of the bearing for proper operation of the regulator.

To check the location of the bearing, the rotor should be in position in the stator, and the stator top plate should then be assembled in position, without bolting down. The top plate

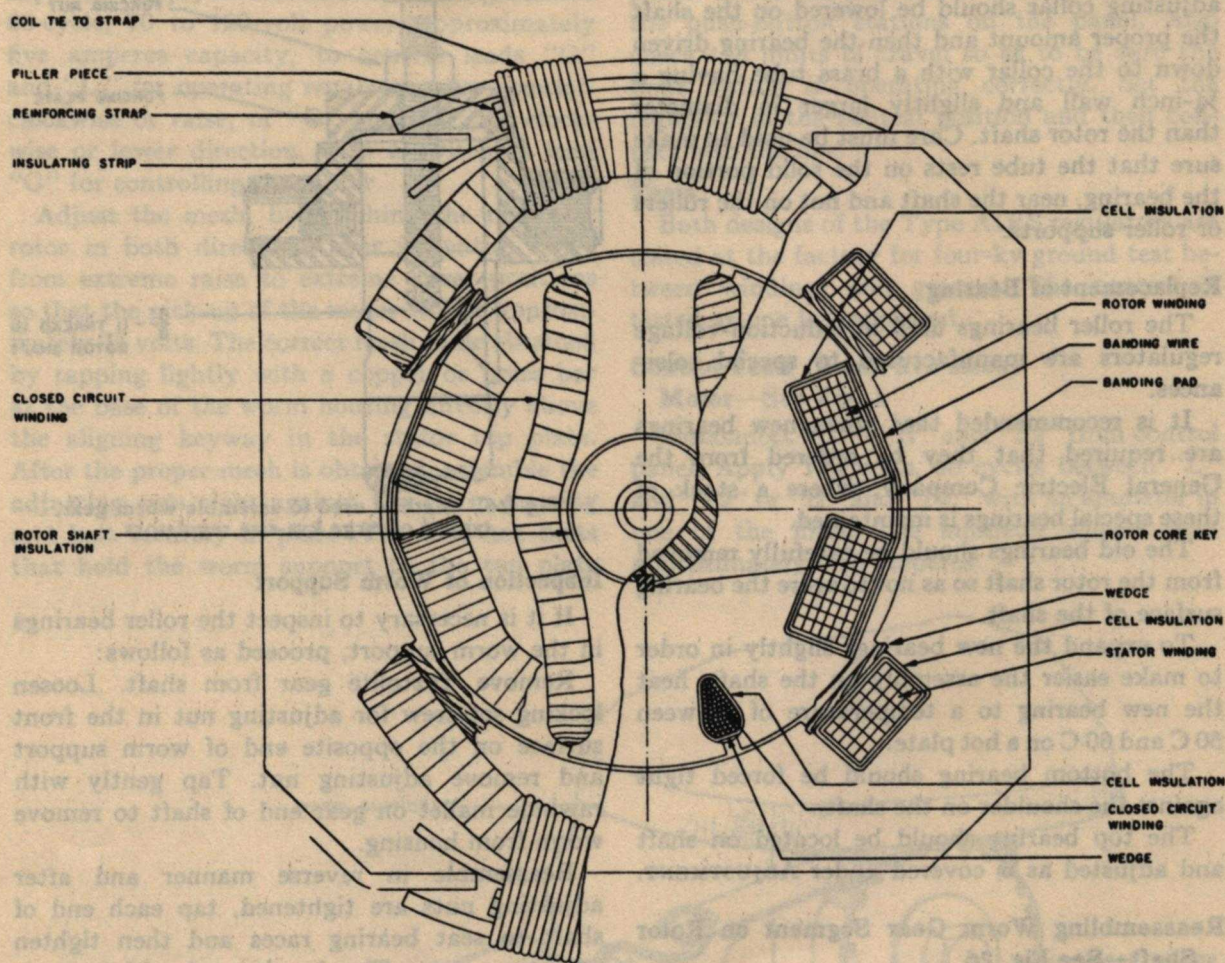

Fig. 25. Location of windings, typical of large kva-size regulators

down of 0.00625 inch. In addition to these holes, there is also a $\frac{3}{8}$ -inch-16 socket-head setscrew for locking the threaded collar in position, to hold the bearing location on the rotor shaft.

The bearing fit on the rotor shaft may be line-to-line or a maximum of 0.001 inch tight.

The correct location of the bearing on the

should be tapped lightly near the bearing race, to make sure that the cone is seated in the cup, and then the space between the top plate and the top of the stator measured with feeler gages at each of the four corners. If this space is 0.005 inch, the top plate should be bolted down. After bolting down, tap the top plate lightly near the bearing, and then release the

four corner bolts and check the spacing on each corner to see that it is correct, before proceeding with the assembly.

If the bearing is too low, it should be forced up with the adjusting collar until the 0.005 inch clearance between the stator top plate and the stator is obtained. If the bearing is too high, the adjusting collar should be lowered on the shaft the proper amount and then the bearing driven down to the collar with a brass tube having a $\frac{1}{4}$ -inch wall and slightly larger in diameter than the rotor shaft. Care must be used to make sure that the tube rests on the solid portion of the bearing, near the shaft and not on the rollers or roller supports.

Replacement of Bearing

The roller bearings used in induction-voltage regulators are manufactured to special tolerances.

It is recommended that when new bearings are required that they be ordered from the General Electric Company, where a stock of these special bearings is maintained.

The old bearings should be carefully removed from the rotor shaft so as not to score the bearing surface of the shaft.

To expand the new bearings slightly in order to make easier the assembly on the shaft, heat the new bearing to a temperature of between 50 C and 60 C on a hot plate.

The bottom bearing should be forced tight against the shoulder on the shaft.

The top bearing should be located on shaft and adjusted as is covered under ADJUSTMENT.

Reassembling Worm Gear Segment on Rotor Shaft—See Fig. 26

Heat the worm gear in an oven, to approximately 100 C. Start the worm gear on the rotor shaft by lightly tapping with a rawhide mallet on the top face of hub of gear only. Use a forcing fixture, Fig. 26, assembled in the $\frac{5}{8}$ -inch-11 tapped hole in end of rotor shaft and force gear on shaft to approximate location. To locate correctly, set worm support on top stator plate and check mesh of worm with gear by coating threads of worm with Prussian blue. The worm

gear must mesh accurately for the proper operation of the regulators. After proper mesh is obtained, the aligning key should be put into keyway in stator top plate and then the worm support should be bolted into place.

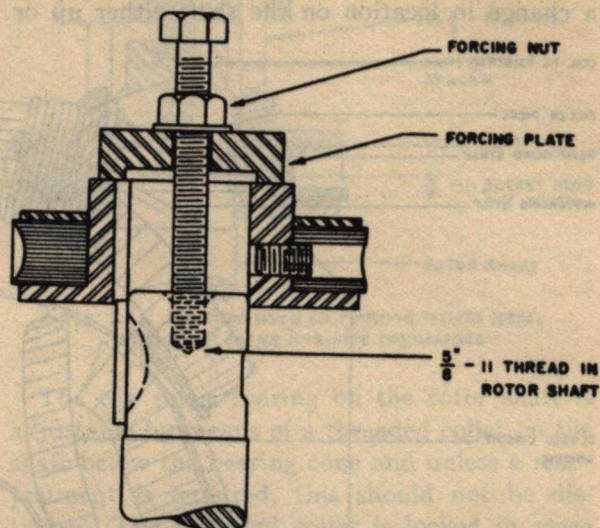

Fig. 26. Method used to assemble worm gear, typical of large kva-size regulators

Inspection of Worm Support

If it is necessary to inspect the roller bearings in the worm support, proceed as follows:

Remove Textolite gear from shaft. Loosen locking setscrew for adjusting nut in the front surface on the opposite end of worm support and remove adjusting nut. Tap gently with rawhide mallet on gear end of shaft to remove worm from housing.

Reassemble in reverse manner and after adjusting nuts are tightened, tap each end of shaft to seat bearing races and then tighten adjusting nuts. The bearings should be pre-loaded, Fig. 27, as follows

Wrap a strap around the Textolite gear and use a spring balance to measure the torque, tighten the bearing-adjusting nut until the torque, to turn the worm shaft, is not less than two and one half pounds nor more than three pounds. Tap end of shaft with rawhide mallet to insure thorough seating of bearings and check torque. When properly adjusted, lock the adjusting nut with the setscrew in the worm block.

Assemble the motor on the worm support. Adjust the motor worm with Textolite gear for minimum backlash without the worm binding on the gear.

The mesh between the main worm and worm gear segment should be adjusted for correct operation as follows: Connect motor leads to capacitor. Apply a variable source of ungrounded 60-cycle, 70 to 120-volt power, approximately five amperes capacity, to control leads "G" and "L," for operating regulator rotor counter-clockwise or raise, or "G" and "H" for clockwise or lower direction, with a switch in lead "G" for controlling the motor.

Adjust the mesh, by notching the regulator rotor in both directions over its entire range from extreme raise to extreme lower positions so that the pick-up of the motor will be approximately 75 volts. The correct mesh to be obtained by tapping lightly with a copper or brass bar at the base of the worm housing directly above the aligning keyway in the stator top plate. After the proper mesh is obtained, assemble the adjusting cam tight against the worm housing and bolt securely in place. The four hex bolts that hold the worm support to the top plate

should then be loosened and retightened consecutively to relieve the strains caused when making adjustments. Recheck motor pick-up voltage to make sure that the adjustment is correct.

Set the regulator in the neutral position. Reassemble the dust-tight casing and the control panel. Check the rotation of the regulator from the push-button stations on the panel. Also check the limits of travel so as to be sure the limit switch is operating correctly. Set the regulator in the neutral position and then connect into the line.

Tests

Both designs of the Type AIRS regulators are tested at the factory for four-kv ground test between windings and ground. The control is tested at one kv to ground.

Control Tests (Small kva sizes)

Motor—See Fig. 1

Disconnect "L"—"H" and "T2" from control panel. Apply 120 volts, 60 cycles between "L" and "T2" or "H" and "T2," with an ammeter in one of the lines. The ammeter should read approximately 0.95 amperes.

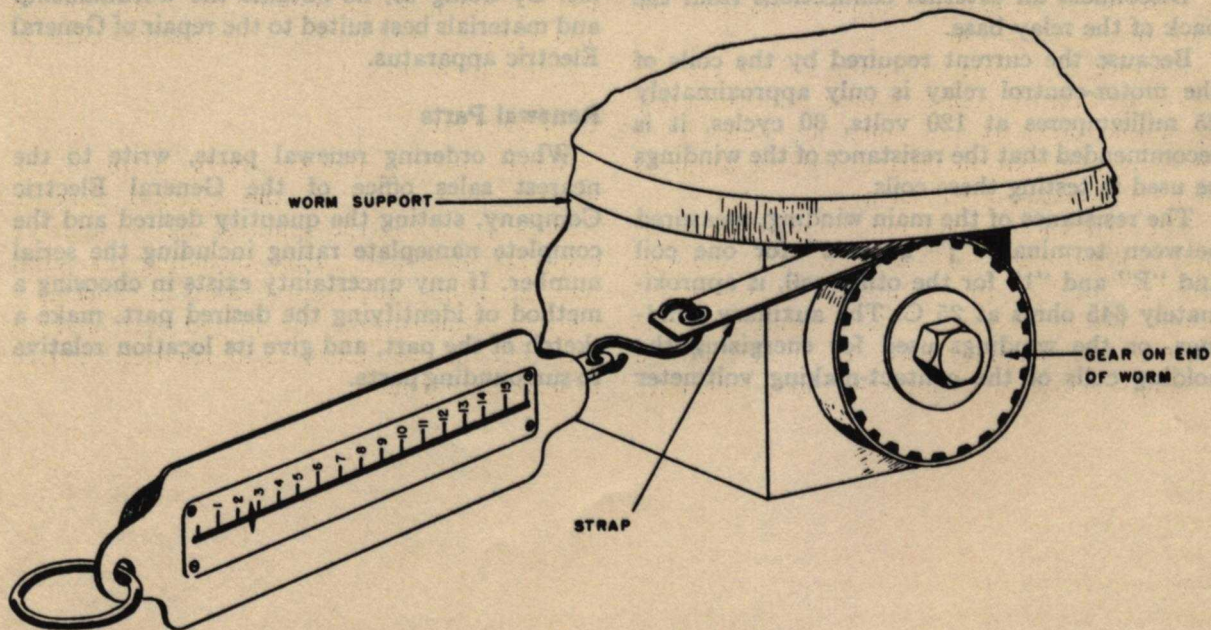

Fig. 27. Method used to preload worm bearings, typical of large kva-size regulators

Motor Capacitor

Disconnect motor leads "T1" and "T3" from capacitor and apply 120 volts, 60 cycles across the capacitor with an ammeter in one line. The ammeter should read approximately 0.55 amperes. Discharge capacitor.

Control Tests (Large kva sizes)

Motor—See Fig. 2

Disconnect leads "L"—"H" between terminal board on regulator and control panel. Apply 120 volts, 60 cycles to "T1" and ground or "T3" and ground with an ammeter in one of the lines. The ammeter should read approximately 1.25 amperes.

Motor Capacitor

Disconnect all of the leads from the capacitor. Apply 120 volts, 60 cycles across the capacitor terminals with an ammeter in one line. The ammeter should read approximately 0.7 amperes. Discharge the capacitor before reconnecting.

Control (All kva sizes)

Motor Control Relay—See Fig. 18

Disconnect all external connections from the back of the relay base.

Because the current required by the coils of the motor-control relay is only approximately 25 milliamperes at 120 volts, 60 cycles, it is recommended that the resistance of the windings be used in testing these coils.

The resistance of the main winding, measured between terminals "J" and "2" for one coil and "F" and "1" for the other coil, is approximately 645 ohms at 25 C. The auxiliary windings, or the windings used for energizing the holding coils of the contact-making voltmeter

should be measured between terminals "8" and "S" for one coil and "7" and "V" for the other coil. This value should be approximately 70 ohms.

Type TSB-20 Contact-making Voltmeter—See Fig. 1 and 2

Disconnect all external connections from the terminal studs on the back of the meter.

The current required by the main solenoid coil and the holding coils is so small, it is recommended that the coils be tested by resistance measurement. The main solenoid coil resistance should be measured between stud "4" and "5." This value should be approximately ten ohms at 25 C. The holding or compensating coils should be measured between studs "7" and "V" for the upper coil and "8" and "V" for the lower coil. The value for each coil should be approximately 72 ohms.

Repairs

One of the significant features of the General Electric Company's extensive program is the widespread establishment of service shops. The Purchaser is urged to avail himself of this service. By doing so, he obtains the workmanship and materials best suited to the repair of General Electric apparatus.

Renewal Parts

When ordering renewal parts, write to the nearest sales office of the General Electric Company, stating the quantity desired and the complete nameplate rating including the serial number. If any uncertainty exists in choosing a method of identifying the desired part, make a sketch of the part, and give its location relative to surrounding parts.

WHEN SERVICE IS REQUIRED

When service is required, the user should refer to the instructions for the specific model of the device. The instructions are located in the user manual or on the product label. It is important to read the instructions carefully to ensure safe and proper use of the device.

GENERAL ELECTRICAL SERVICE

The following information is provided for general electrical service. It is intended to provide a general overview of the electrical requirements and safety considerations for the device. For more detailed information, please refer to the user manual or contact your local electrical service provider.

GENERAL ELECTRICAL SERVICE
INSTRUCTIONS

WHEN SERVICE IS REQUIRED

GENERAL ELECTRIC operates 23 apparatus service shops strategically located and competently manned by trained personnel. Each shop is a complete service unit with modern equipment for repairing, reconditioning, and rebuilding G-E apparatus to factory specifications. The services of these shops are available at any time of day or night for work in the shops or on purchaser's premises.

GENERAL ELECTRIC APPARATUS SERVICE SHOPS

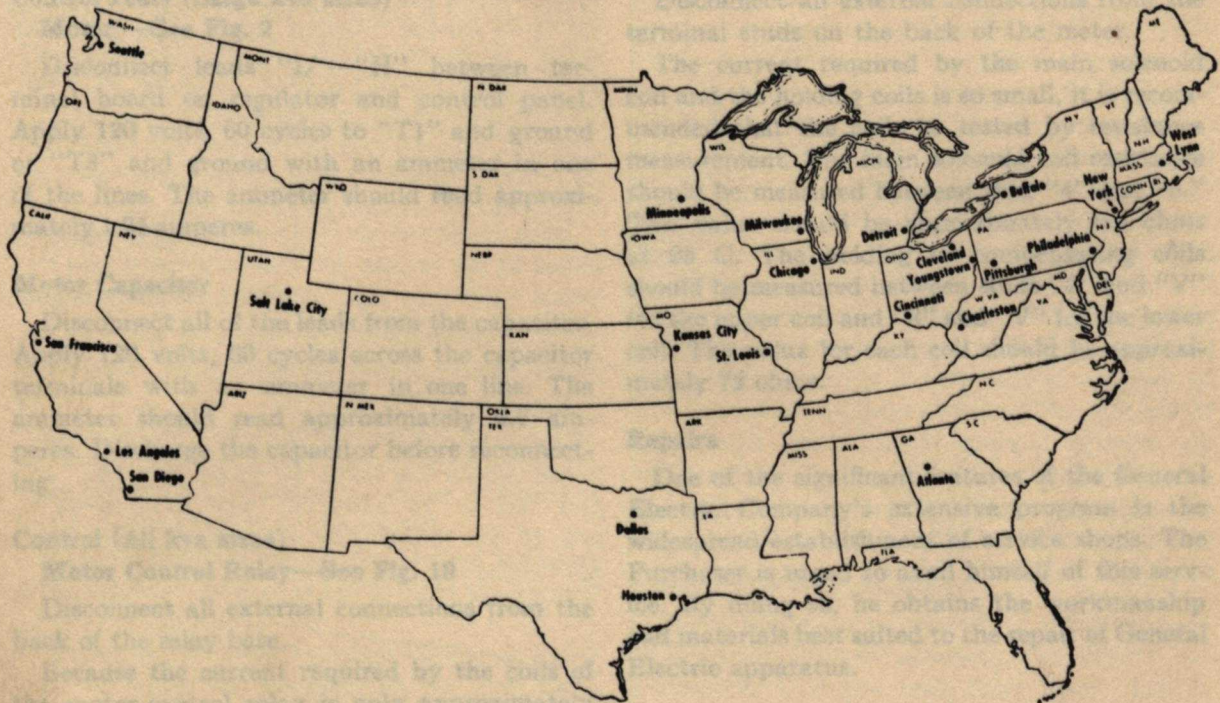

SERVICE SHOP

Atlanta, Ga.
 Buffalo 11, N. Y.
 Charleston 28, W. Va.
 Chicago 7, Ill.
 Cincinnati 2, Ohio
 Cleveland 4, Ohio
 Dallas 2, Texas
 Detroit 2, Mich.
 Houston 1, Texas
 Kansas City 8, Mo.
 Los Angeles 54, Calif.
 Milwaukee 3, Wis.
 Minneapolis 1, Minn.
 New York 14, N. Y.
 Philadelphia 23, Pa.
 Pittsburgh 6, Pa.
 St. Louis 1, Mo.
 Salt Lake City 9, Utah
 San Diego 1, Calif.
 San Francisco 7, Calif.
 Seattle 4, Wash.
 West Lynn 3, Mass.
 Youngstown 3, Ohio

ADDRESS

496 Glenn Street, S.W.
 318 Urban Street
 306 MacCorkle Avenue, S.E.
 849 South Clinton St.
 215 West Third Street
 4966 Woodland Avenue
 1801 North Lamar St.
 5950 Third Avenue
 1312 Live Oak Street
 819 East 19th Street
 733 Banning Street
 940 W. St. Paul Ave.
 410 Third Ave., N.
 416 West 13th Street
 429 N. Seventh St.
 6519 Penn Avenue
 1110 Delmar Avenue
 141 South Third West St.
 2045 Kettner Blvd.
 361 Bryant Street
 1508 4th Ave., South
 920 Western Avenue
 121 East Boardman St.

DAY PHONE

WAlnut-9667
 HU-5849
 2-6177
 Wabash-5611
 Parkway-3433
 EN-4464
 R-9121
 TRinity-2-2600
 C-9711
 Victor-9745
 Madison-7381
 Marquette-5000
 Main-2541
 Wickersham-2-1311
 Pennypacker-9000
 Atlantic-6400
 Chestnut-8505
 4-1892
 Franklin-7684
 DO-3740
 Elliott-1778
 Ly-3-6000
 Youngstown-44331

NIGHT PHONE

WAlnut-7859
 RI-7579
 3-1244
 Wabash-5654
 Parkway-3433
 EN-4464
 L-4111
 TRinity-2-2606
 C-9714
 WAbash-3850
 Madison-1813
 Marquette-5002
 Main-2546
 Chelsea-2-8390
 Pennypacker-8448
 Atlantic-6408
 Chestnut-3899
 6-4448
 Glencove-5-3675
 DO-3748
 CA-3679
 Ly-3-6008
 Youngstown-44331

APPARATUS DEPARTMENT

GENERAL ELECTRIC

SCHENECTADY, N. Y.